

BUTCHER BOY TCA22 COUNTER TOP GRINDER

OPERATING INSTRUCTIONS AND PARTS MANUAL



MANUFACTURED BY:

AMERICAN MEAT EQUIPMENT LLC.
640 MULBERRY AVE.
SELMER, TN 38375
PH: 1-731-434-1012 • FAX 1-731-645-6056

website: www.butcherboymachines.com

BUTCHER BOY TCA22 COUNTER TOP GRINDER

Before installing, operating or cleaning the TCA22 GRINDER all persons coming into contact with this equipment must read and completely understand the contents of this document.

If you have any doubts about the installation, operation or cleaning of this equipment contact the dealer from which the equipment was purchased or contact the factory.

BUTCHER BOY GRINDERS are manufactured solely to cut meat, chicken and fish. The grinders are not intended for other purposes.

UPON RECEIPT OF THE GRINDER: Thoroughly inspect the grinder for any damage that may have occurred during transit. If damage is detected contact the carrier for instructions.

A. INSTALLATION:

Unpack and place the grinder on a stable flat surface at a convenient height to the operator. Make sure the grinder is configured as ordered. The legs are equipped with 3" risers. These risers may be removed or added to as needed. 120 Volt single phase machines are equipped with a 15 amp cord set. This may be plugged into any 15 amp outlet.

On 230 volt single phase and 230/460 volt three phase machines a cord is provided for the electrician to attach the correct plug. On three phase motors be sure of correct rotation.

Electrical connections must be made by a qualified electrician and comply with all codes.

SAFETY FEATURES:

BOWL GUARD: Stays with the bowl when the pan is removed.

MEAT STOMPER: Included, used to push meat into bowl through guard.

B. TO REMOVE THE PAN FROM BOWL:

LOCKOUT THE ELECTRICAL POWER!

Loosen thumbscrew and lift pan over guard while moving pan toward rear of machine.

C. TO REMOVE BOWL FROM MACHINE:

LOCKOUT THE ELECTRICAL POWER!

Remove knife and plate ring, pull out feed screw. Rotate lock handle toward front of bowl to approximately the 12:00 o'clock position. Pull bowl from gearbox (you may need to wiggle the lock handle slightly). Reverse the removal procedure to reassemble.

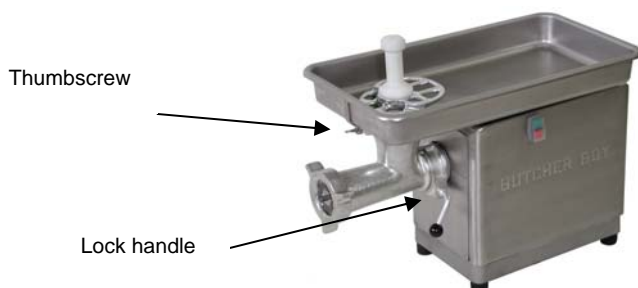

BUTCHER BOY TCA22 COUNTER TOP GRINDER

D. TO CLEAN THE TCA22:

LOCKOUT THE ELECTRICAL POWER!

Remove the pan, stomper and cutting group. Wash the removed parts in your approved cleaning solution. Wipe or blow dry the removed parts, sanitize and then apply an approved mineral oil. Hand wipe the cabinet, sanitize and then apply an approved mineral oil. **DO NOT IMMERSER THE CABINET.** (Follow your facility sanitation procedures if our instructions conflict with your procedures).

OPERATING INSTRUCTIONS

THE TCA22 BOWL IS EQUIPPED WITH A PERMANENTLY ATTACHED SAFETY GUARD. SHOULD THE GUARD BE BROKEN OR IN ANY WAY ALLOW ENTRY INTO THE GRINDER **DO NOT USE THE GRINDER.** THE BOWL MUST BE REPAIRED OR REPLACED IMMEDIATELY.

REPLACE THE STOMPER WHEN WORN OR BROKEN.

ALWAYS:

DISCONNECT THE ELECTRICAL POWER TO THE MACHINE WHEN NOT IN USE!

NEVER:

PUT HANDS IN MACHINE WHEN MACHINE IS RUNNING!

NEVER:

CLEAN WITH POWER ON!

NEVER:

SERVICE WITH POWER ON!

When preparing to grind be sure plate and knife are sharp (plates and knives should be kept as matched sets) and the holes in the plate are the proper size. PLATES WITH HOLES LARGER THAN 3/8" SHOULD NOT BE USED WITHOUT SPECIAL ATTENTION TO THE POSSIBILITY THAT ACCESS TO THE KNIFE IS POSSIBLE!

Assemble the cutting group (be sure the plate protrudes a minimum 1/8" from the bowl).

Lightly tighten the knife and plate ring against the plate, push the product into the grinder using the stomper. Turn on the machine, run until product appears at the plate, firmly tighten the knife and plate ring, by hand, and you're ready to run production.

MAINTENANCE

The TCA22 is manufactured to require very little maintenance. Upon daily cleaning look for obvious wear on the feed screw, stud and chuck. Under normal operation have your service company replace the oil and check the belts every 12 months.

There are no user serviceable electrical components in the TCA22.

BUTCHER BOY TCA22 COUNTER TOP GRINDER

CUTTING GROUP & MISCELLANEOUS

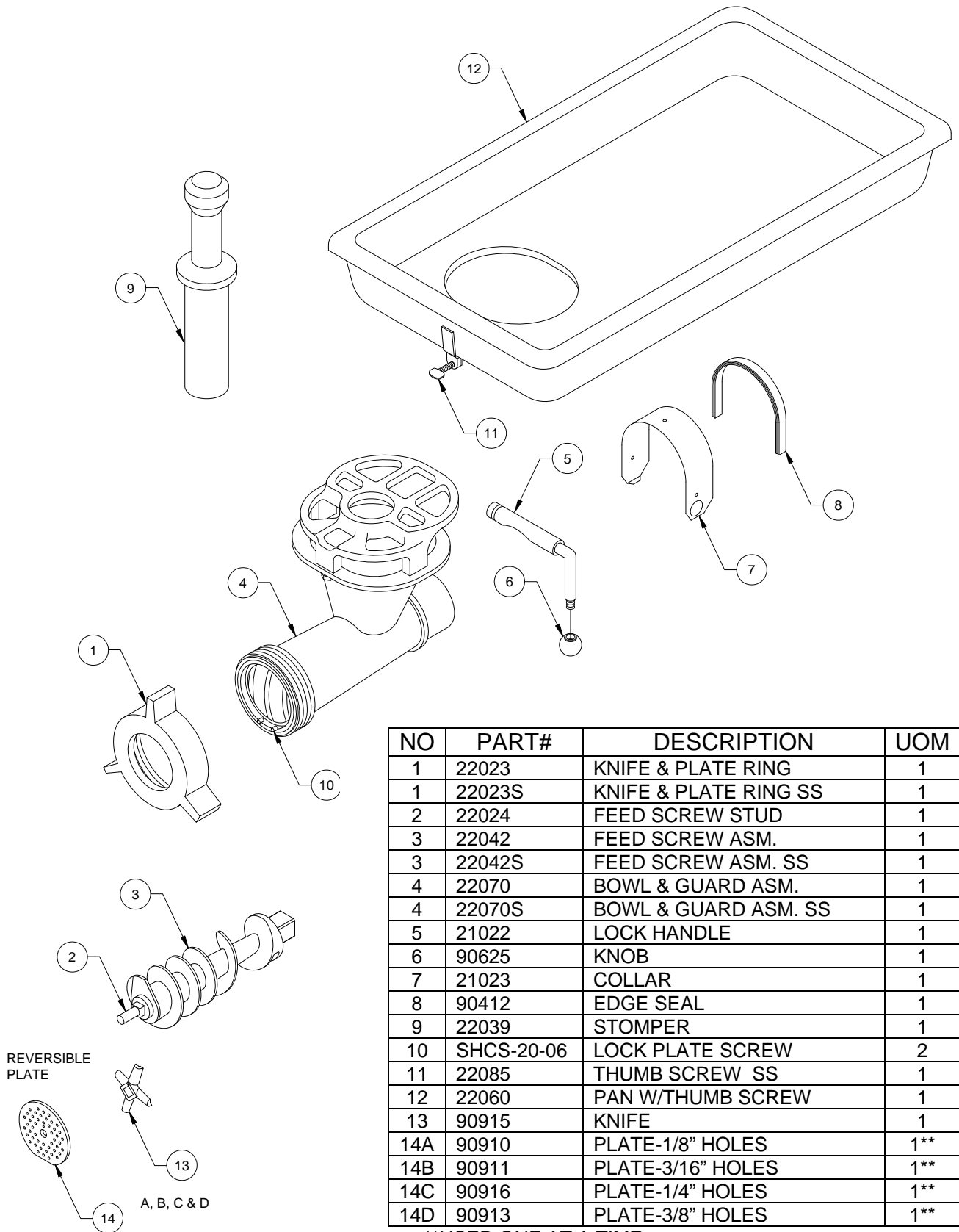

**USED ONE AT A TIME

BUTCHER BOY TCA22 COUNTER TOP GRINDER

GEAR BOX

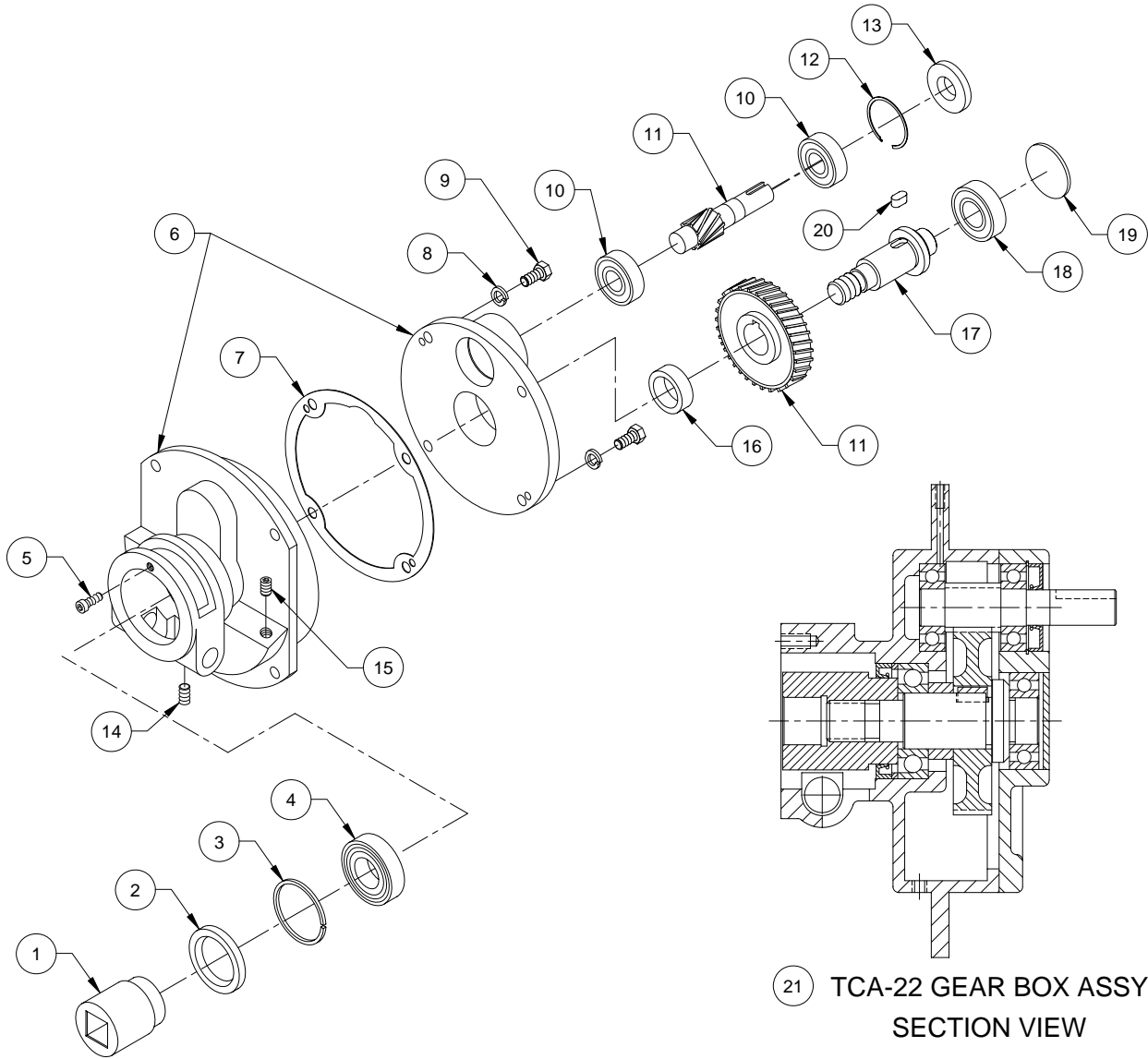

NO	PART#	DESCRIPTION	UOM
1	21006	FEED SCREW CHUCK	1
2	90409	SEAL	1
3	21010	SPACER	1
4	90308	THRUST BEARING	1
5	SHCS-21-06-SS	SCREW	1
6	21013	HOUSING & COVER	1
7	21004	GASKET	1
8	SLW-06-SS	WASHER	4
9	HHCS-23-06-SS	SCREW	4
10	90307	BALL BEARING	2
11	21005	GEAR AND PINION	1SET

NO	PART#	DESCRIPTION	UOM
12	90221	SNAP RING	1
13	90410	SEAL	1
14	95518	PLUG	1
15	90634	PLUG	1
16	21011	SPACER	1
17	21008	DRIVE SHAFT	1
18	90302	BALL BEARING	1
19	21007	SEAL PLUG	1
20	59248-10	KEY	1
21	21002	GEAR BOX ASM.	1

BUTCHER BOY TCA22 COUNTER TOP GRINDER

FRAME & DRIVE

MOTORS				
HP	VOLTAGE	PHASE	FLA	PART#
1.0	115	1	8.6	92030
1.5	208	1	9.5	92079
1.5	230	1	9.0	92079
1.5	208	3	4.5	92094
1.5	230	3	4.2	92094
1.5	460	3	2.1	92094
2.0	208	3	5.9	92118
2.0	230	3	5.6	92118
2.0	460	3	2.8	92118

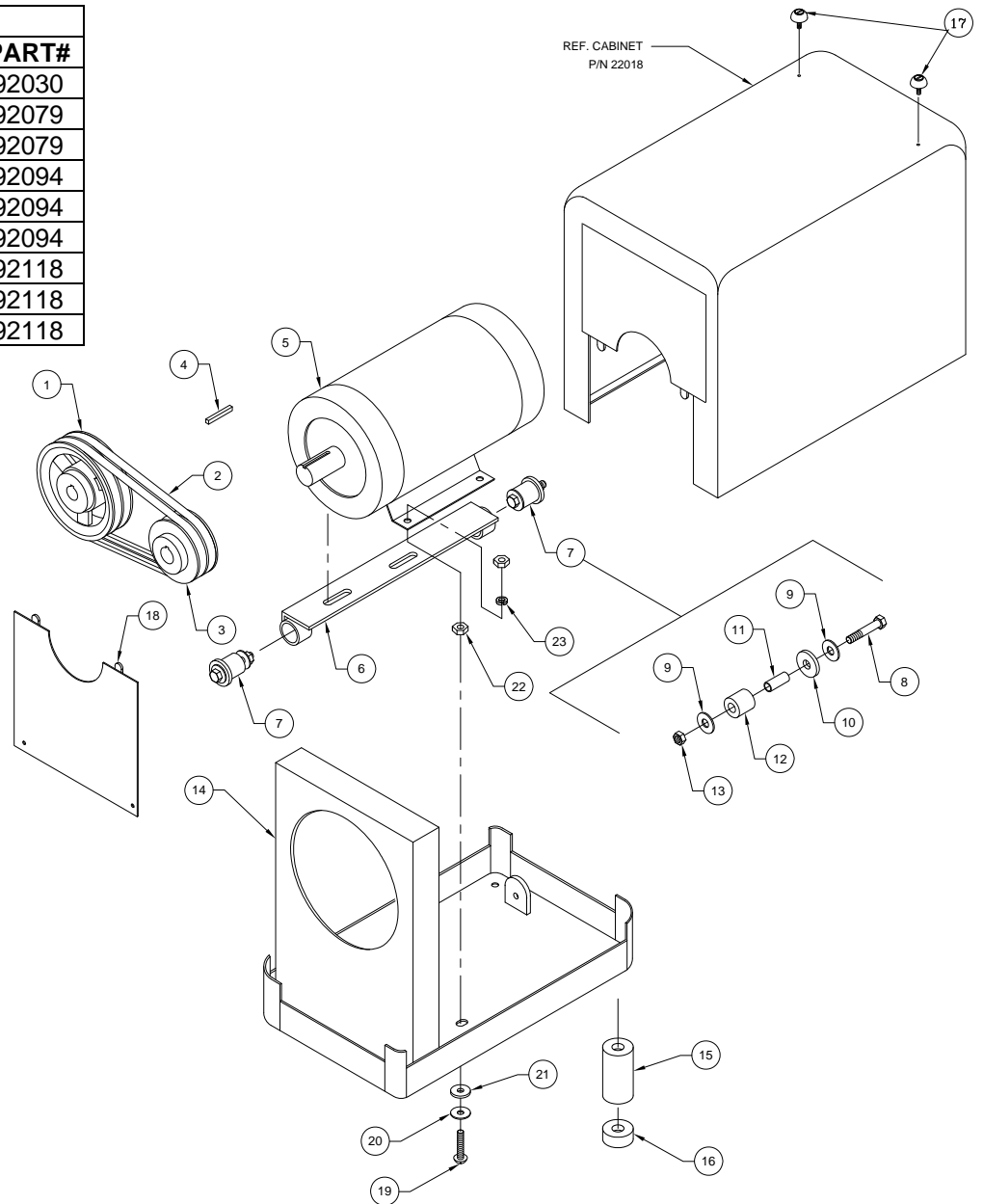

NO	PART#	DESCRIPTION	UOM	NO	PART#	DESCRIPTION	UOM
1	90126	DRIVEN PULLEY	1	13	HN-23S	NUT	2
2	90508	BELT	2	14	22033S	BASE SS	1
3	90199-143	PULLEY-1hp single phase	1	15	21031	LEG EXTENSION	4
3	90128	PULLEY-1 1/2 & 2 HP	1	16	95753	RUBBER FOOT	4
4	59246-7	KEY	1	17	90631	PAN SUPPORT	2
5	MOTOR	SEE: CHART ABOVE	1	18	22052	FRONT PLATE	1
6	22030S	MOTOR MOUNT SS	1	19	RHSS-21-48	SCREW	1
7	21030	RUBBER BUSHING ASM.	2	20	FW-21-SS	FLAT WASHER	1
8	HHCS-23-32S	SCREW	2	21	0090602	RUBBER WASHER	1
9	FW-06S	WASHER	4	22	HN-21-SS	HEX NUT	2
10	90632	RUBBER WASHER	2	23	ESW-21-SS	SHAKE PROOF WASHER	1
11	10117	SLEEVE	2				
12	21041	RUBBER BUSHING	2				

BUTCHER BOY TCA22 COUNTER TOP GRINDER

FRAME & DRIVE-50HZ

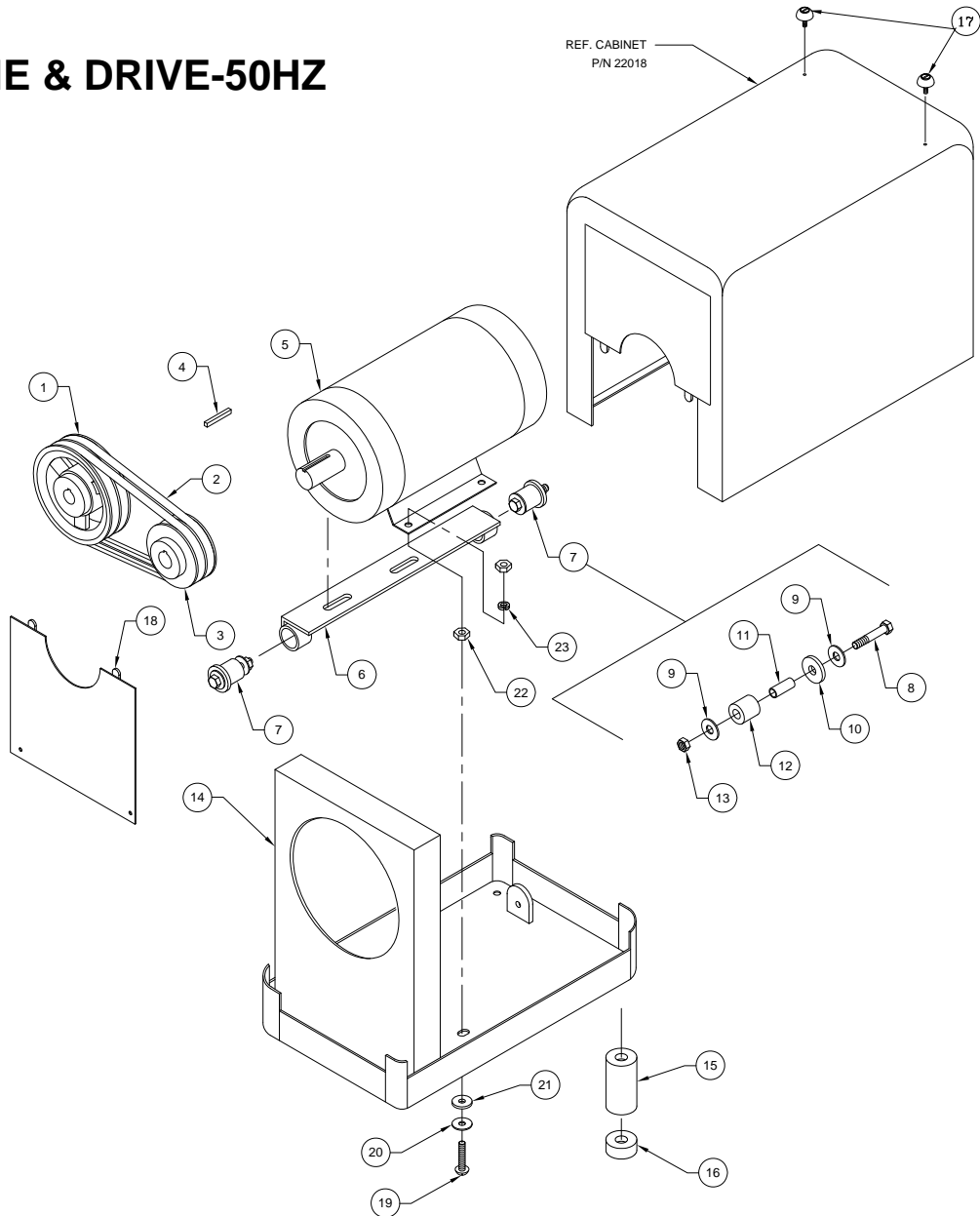

NO	PART#	DESCRIPTION	UOM
1	90126	DRIVEN PULLEY	1
2	90508	BELT	2
3	90199-150	PULLEY-2 HP-50HZ	1
4	59246-7	KEY	1
5	92143-50HZ	MOTOR-50HZ	1
6	22030S	MOTOR MOUNT SS	1
7	21030	RUBBER BUSHING ASM.	2
8	HHCS-23-32S	SCREW	2
9	FW-06S	WASHER	4
10	90632	RUBBER WASHER	2
11	10117	SLEEVE	2
12	21041	RUBBER BUSHING	2
13	HN-23S	NUT	2
14	22033S	BASE SS	1
15	21031	LEG EXTENSION	4
16	95753	RUBBER FOOT	4
17	90631	PAN SUPPORT	2
18	22052	FRONT PLATE	1

BUTCHER BOY TCA22 COUNTER TOP GRINDER

ELECTRICAL COMPONENTS

THIS PAGE FOR USE BY QUALIFIED REPAIR TECHNICIANS ONLY

115 VOLTS SINGLE PHASE

208/230/460 VOLTS 1 & 3 PHASE

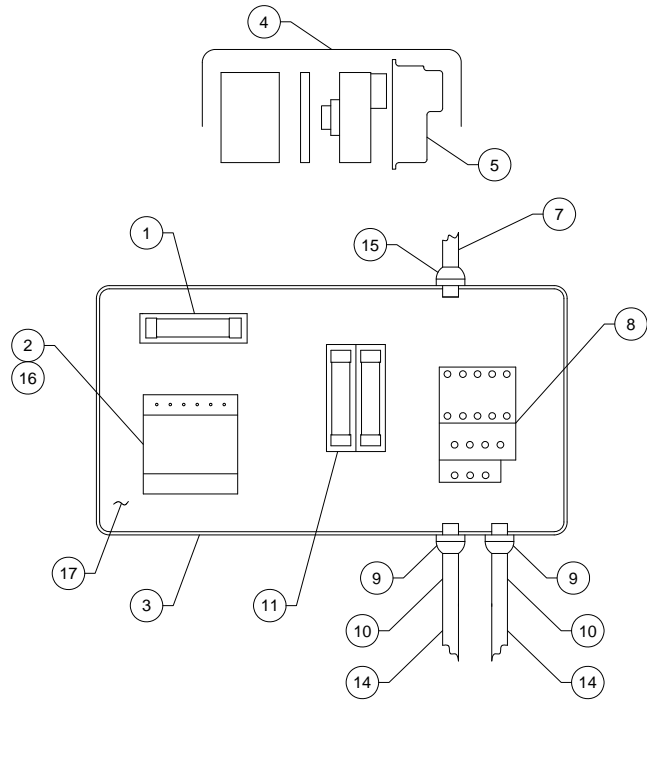
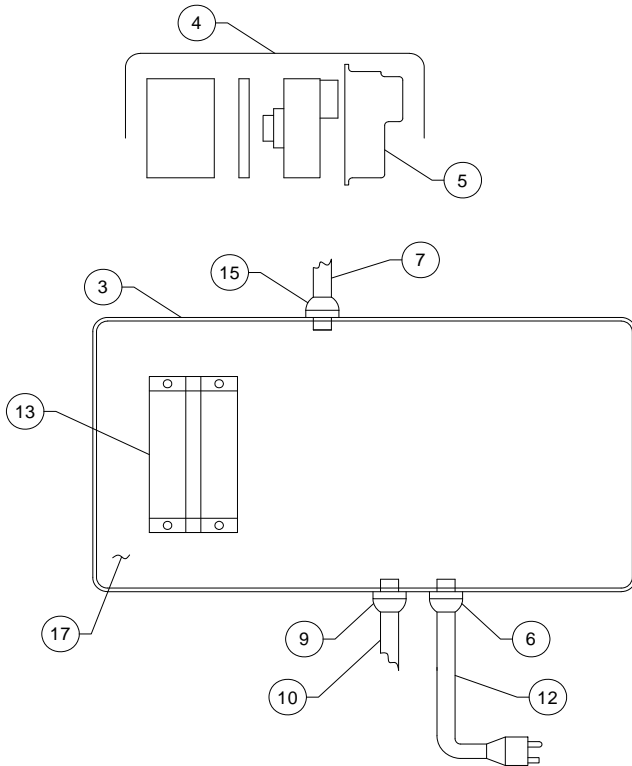

ITEM#	DESCRIPTION	PART#	UOM	ITEM#	DESCRIPTION	PART#	UOM
1	FUSE BLOCK (F2)	93999-049	0,1	10	CORD 14/3	90627	FT
2	TRANSFORMER-230/460V	93999-095	0,1	11	FUSE BLOCK (F1)	93999-024	0,1
3	ENCLOSURE	93999-128	1,1	12	CORD SET 14/3	95450	0,1
4	START/STOP SWITCH	93999-129	1	13	RELAY 1 HP 115V	BELOW	1
5	SWITCH MEMBRANE	93999-130	1	14	CORD 14/4	90666	FT
6	STRAIN RELIEF	93999-132	1	15	STRAIN RELIEF	93999-133	1,1
7	CORD 16/3	90665	FT	16	TRANSFORMER-208V	93999-230	0,1
8	MOTOR STARTER	BELOW	0,1	17	PANEL	0022096	1
9	STRAIN RELIEF	93999-131	1,2				

HP	VOLTAGE	PHASE	FLA	MOTOR PART#	*F1	FUSE PART#	**F2	FUSE PART#	STARTER***
1.0	115	1	8.6	92030	N/A	N/A	N/A	N/A	93999-125
1.5	208	1	7.0	92079	.30	0093999-025	2.8	0093999-018	93999-121
1.5	230	1	6.25	92079	.30	0093999-025	2.8	0093999-018	93999-121
1.5	208	3	4.5	92094	.30	0093999-025	2.8	0093999-018	93999-122
1.5	230	3	4.2	92094	.30	0093999-025	2.8	0093999-018	93999-122
1.5	460	3	2.1	92094	.15	0093999-014	2.8	0093999-018	93999-124
2.0	208	3	5.9	92118	.30	0093999-025	2.8	0093999-018	93999-121
2.0	230	3	5.6	92118	.30	0093999-025	2.8	0093999-018	93999-121
2.0	460	3	2.8	92118	.15	0093999-017	2.8	0093999-018	93999-123

* USE CLASS "CC" FUSE ONLY. ** USE TYPE "FLM" FUSE. *** CONTACTOR AND OVERLOAD EXCEPT 115 VOLT

BUTCHER BOY TCA22 COUNTER TOP GRINDER

ELECTRICAL COMPONENTS

THIS PAGE FOR USE BY QUALIFIED REPAIR TECHNICIANS ONLY

208/230/460 VOLTS 3 PHASE-50HZ

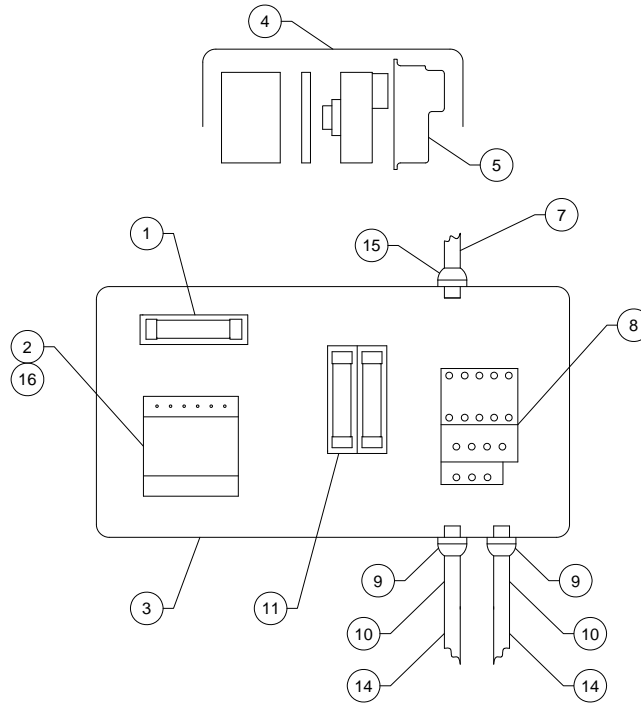

ITEM#	DESCRIPTION	PART#	UOM
1	FUSE BLOCK (F2)	93999-049	1
2	TRANSFORMER-230/460v	93999-095	1
3	ENCLOSURE	93999-128	1
4	START/STOP SWITCH	93999-129	1
5	SWITCH MEMBRANE	93999-130	1
6			
7	CORD 16/3	90665	FT
8	MOTOR STARTER	BELOW	1

ITEM#	DDESCRIPTION	PART#	UOM
9	STRAIN RELIEF	93999-131	1,2
10	CORD 14/3	90627	FT
11	FUSE BLOCK (FI)	93999-024	0,1
12			
13			
14	CORD 14/4	90666	FT
15	STRAIN RELIEF	93999-133	1,1
16	TRANSFORMER-208V	93999-230	0,1

HP	VOLTAGE	PHASE	FLA	MOTOR PART#	*F1	FUSE PART#	**F2	FUSE PART#	STARTER***
2.0	208	3	5.9	92118	.30	0093999-025	2.8	0093999-018	93999-121
2.0	230	3	5.6	92118	.30	0093999-025	2.8	0093999-018	93999-121
2.0	460	3	2.8	92118	.15	0093999-017	2.8	0093999-018	93999-123

* USE CLASS "CC" FUSE ONLY. ** USE TYPE "FLM" FUSE. *** CONTACTOR AND OVERLOAD EXCEPT 115 VOLT

BUTCHER BOY TCA22 COUNTER TOP GRINDER

ELECTRICAL COMPONENTS

THIS PAGE FOR USE BY QUALIFIED REPAIR TECHNICIANS ONLY

115 VOLTS SINGLE PHASE

208/230/460 VOLTS 1 & 3 PHASE

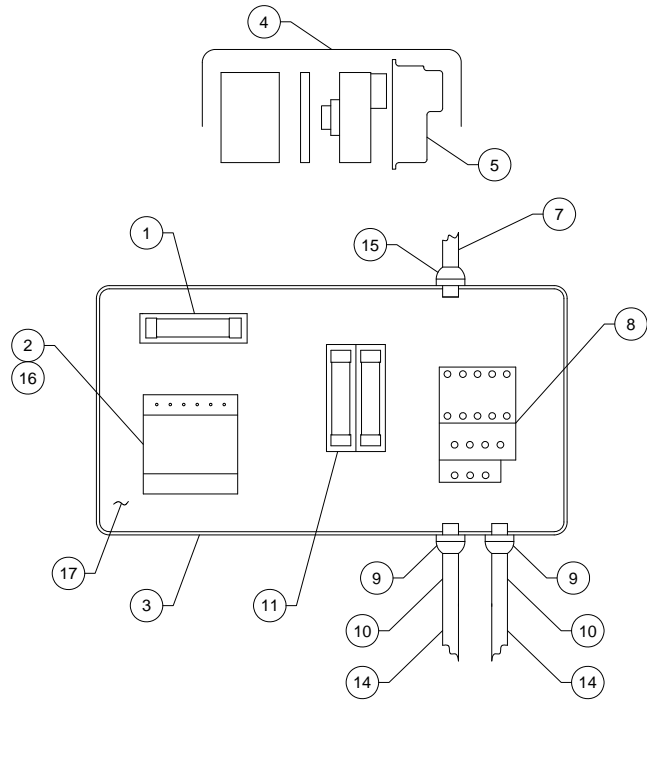
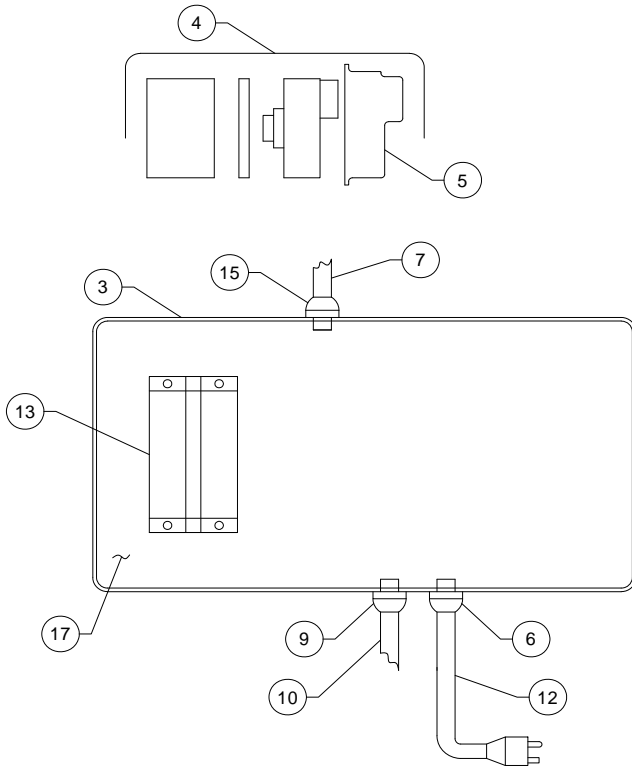

ITEM#	DESCRIPTION	PART#	UOM	ITEM#	DESCRIPTION	PART#	UOM
1	FUSE BLOCK (F2)	93999-049	0,1	10	CORD 14/3	90627	FT
2	TRANSFORMER-230/460V	93999-095	0,1	10	CORD 10/3(1.5HP-115V)	93999-234	FT
3	ENCLOSURE	93999-128	1,1	11	FUSE BLOCK (F1)	93999-024	0,1
4	START/STOP SWITCH	93999-129	1	12	CORD SET 14/3 (FOR 1HP 115V ONLY)	95450	0,1
5	SWITCH MEMBRANE	93999-130	1	13	RELAY 1.5HP 115V	BELOW	1
6	STRAIN RELIEF	93999-132	1	13	RELAY 1HP 115V	BELOW	1
7	CORD 16/3	90665	FT	14	CORD 14/4	90666	FT
8	MOTOR STARTER	BELOW	0,1	15	STRAIN RELIEF	93999-133	1,1
9	STRAIN RELIEF	93999-131	1,2	16	TRANSFORMER-208V	93999-230	0,1
9	STRAIN RELIEF (1.5HP-115V)	93999-253	2	17	PANEL	0022096	1

HP	VOLTAGE	PHASE	FLA	MOTOR PART#	*F1	FUSE PART#	**F2	FUSE PART#	STARTER***
1.0	115	1	8.6	92030	N/A	N/A	N/A	N/A	93999-125
1.5	115	1	12.5	92079	N/A	N/A	N/A	N/A	93999-314
1.5	208	1	9.5	92079	.30	0093999-025	2.8	0093999-018	93999-120
1.5	230	1	9.0	92079	.30	0093999-025	2.8	0093999-018	93999-120
1.5	208	3	4.5	92094	.30	0093999-025	2.8	0093999-018	93999-122
1.5	230	3	4.2	92094	.30	0093999-025	2.8	0093999-018	93999-122
1.5	460	3	2.1	92094	.15	0093999-014	2.8	0093999-018	93999-124
2.0	208	3	5.9	92118	.30	0093999-025	2.8	0093999-018	93999-121
2.0	230	3	5.6	92118	.30	0093999-025	2.8	0093999-018	93999-121
2.0	460	3	2.8	92118	.15	0093999-017	2.8	0093999-018	93999-123

BUTCHER BOY TCA22 COUNTER TOP GRINDER

ELECTRICAL SCHEMATICS

THIS PAGE FOR USE BY QUALIFIED REPAIR TECHNICIANS ONLY

208/230/460 VOLTS 3 PHASE

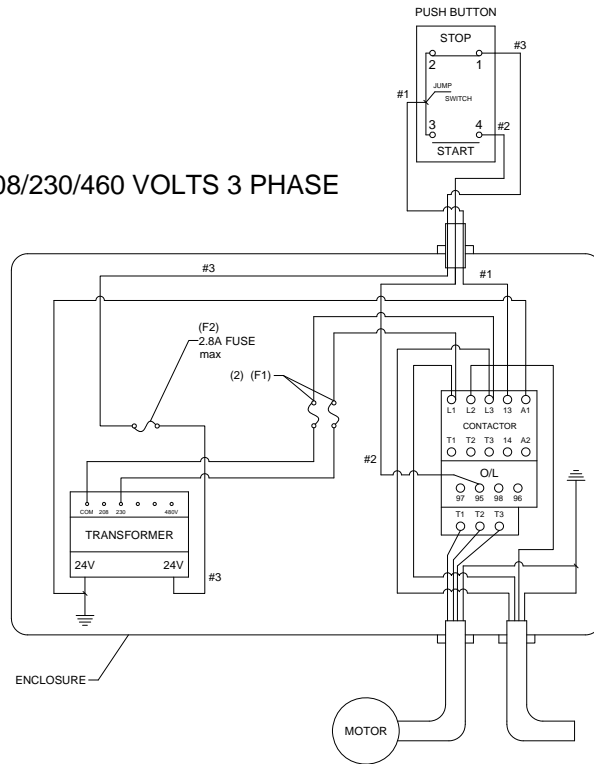

115 VOLTS
SINGLE PHASE

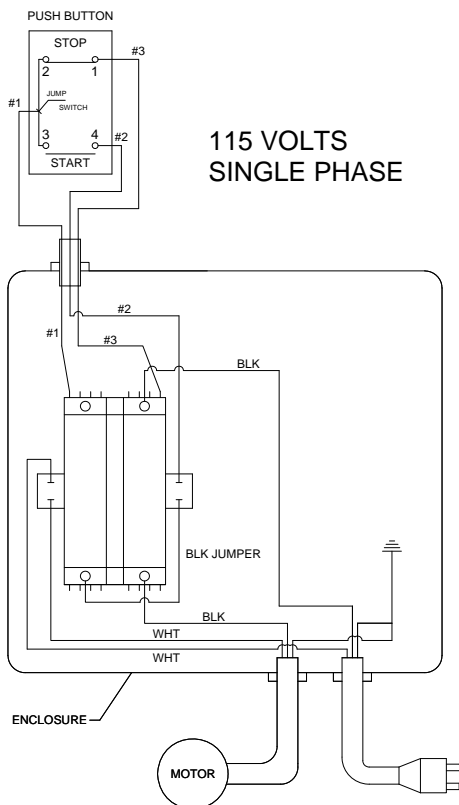

208/230 VOLTS 1 PHASE

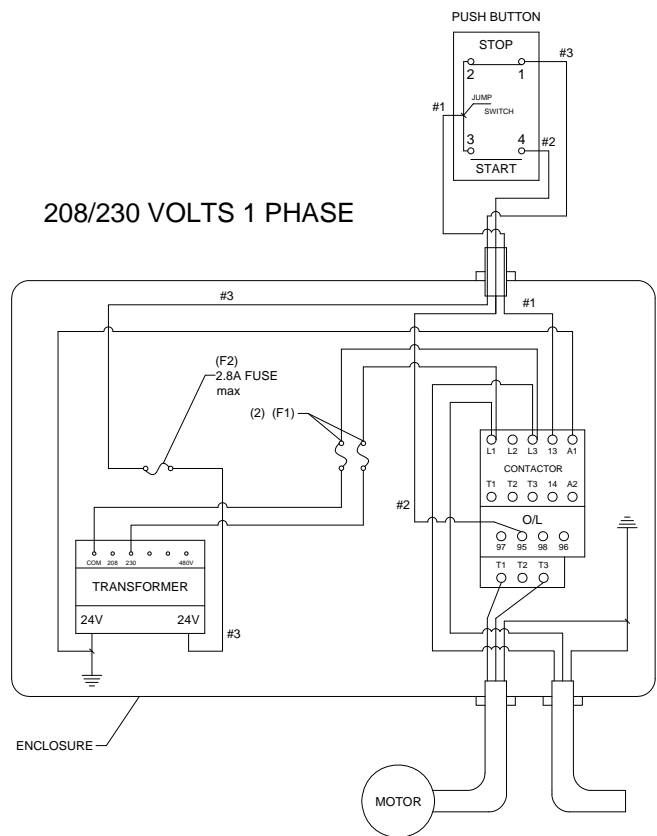

BUTCHER BOY TCA22 COUNTER TOP GRINDER

ELECTRICAL SCHEMATICS

THIS PAGE FOR USE BY QUALIFIED REPAIR TECHNICIANS ONLY

208/230/460 VOLTS 3 PHASE-50HZ

