

B[®]
U
T
C
H
E
R
B
O
Y

250 MIXER
OPERATING INSTRUCTIONS AND PARTS
LIST



MADE IN USA

BUTCHER BOY =
QUALITY

DEPENDABILITY

SERVICE

BUTCHER BOY 250 MIXER

READ AND UNDERSTAND THESE INSTRUCTIONS BEFORE OPERATING THE 250 MIXER!

The 250 Mixer is equipped with an electrical disconnect switch that can be locked in the off position. USE THIS SWITCH TO LOCK OUT THE ELECTRICAL POWER!

The 250 Mixer is intended for **ONE PERSON OPERATION ONLY!** Do not allow others into the proximity of the mixer when product is being discharged!

Installation:

Locate the mixer in a suitable area and have a qualified electrician supply adequate power of the proper voltage and phase. The user provides over-current protection for the mixer at this time.

Operation:

Load the mixer with the product to be mixed. The mixer may be tipped left or right to accommodate loading.

The mixer must be in the upright position with the lid closed to mix. Mixing will commence when the start button on the sloped console is depressed and will continue until the stop button on the console is depressed or alternatively the lid is opened, the E-Stop button is depressed or the lockout switch is turned OFF.

After mixing is complete, raise the lid and rotate the tub to the discharge position. The mixer will operate only at the discharge position and with both buttons on the sides of the console depressed simultaneously and held.

Clean-up:

After the last load is mixed and the mixer is at the discharge position jog the paddle to an easy to remove position. **THE MOTOR IS EQUIPPED WITH A BRAKE! YOU CANNOT MOVE THE PADDLE BY HAND! JOG THE PADDLE INTO POSITION WITH THE TWO HAND BUTTONS!**

LOCK OUT THE ELECTRICAL! Remove the paddle and follow your normal wash down procedures. Reinstall the paddle and you are ready to mix again.

Daily:

On a daily basis before using the 250 Mixer check the function of all the controls. If a malfunction does occur **DO NOT OPERATE THE MIXER!**

Failure to follow the above instructions may place personnel in danger of severe injury!

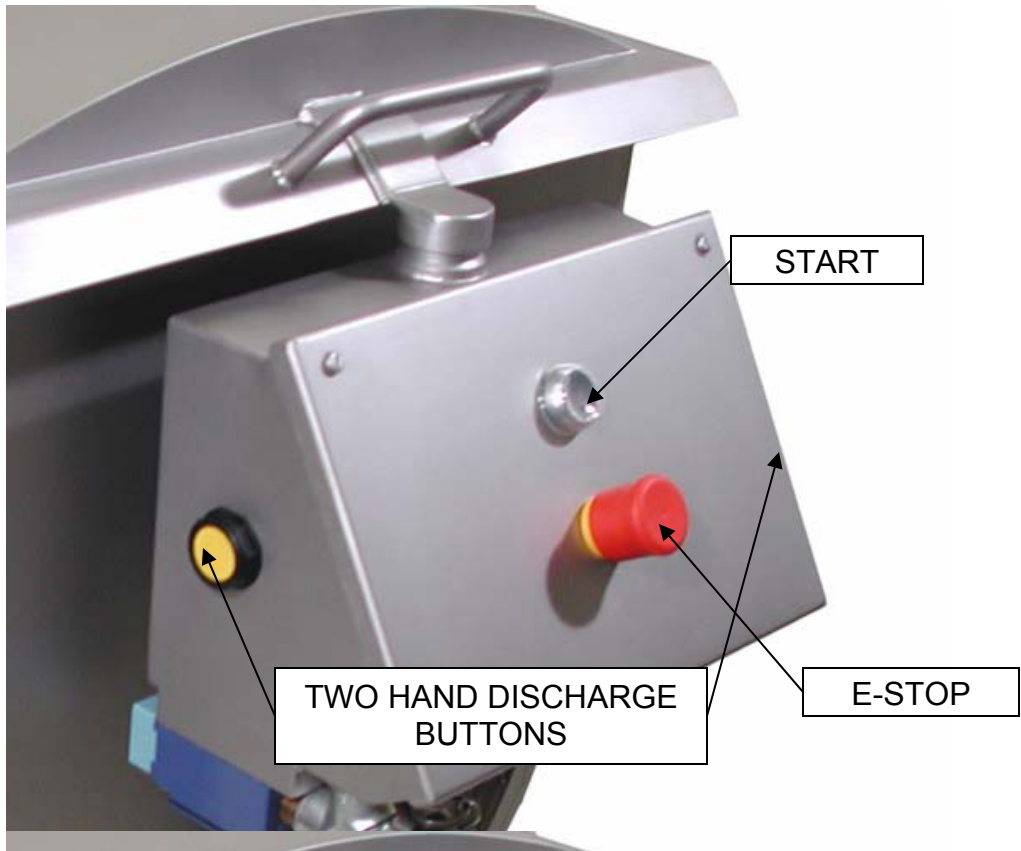

BUTCHER BOY 250 MIXER STAINLESS STEEL

250 MIXER BASE, TUB & LID

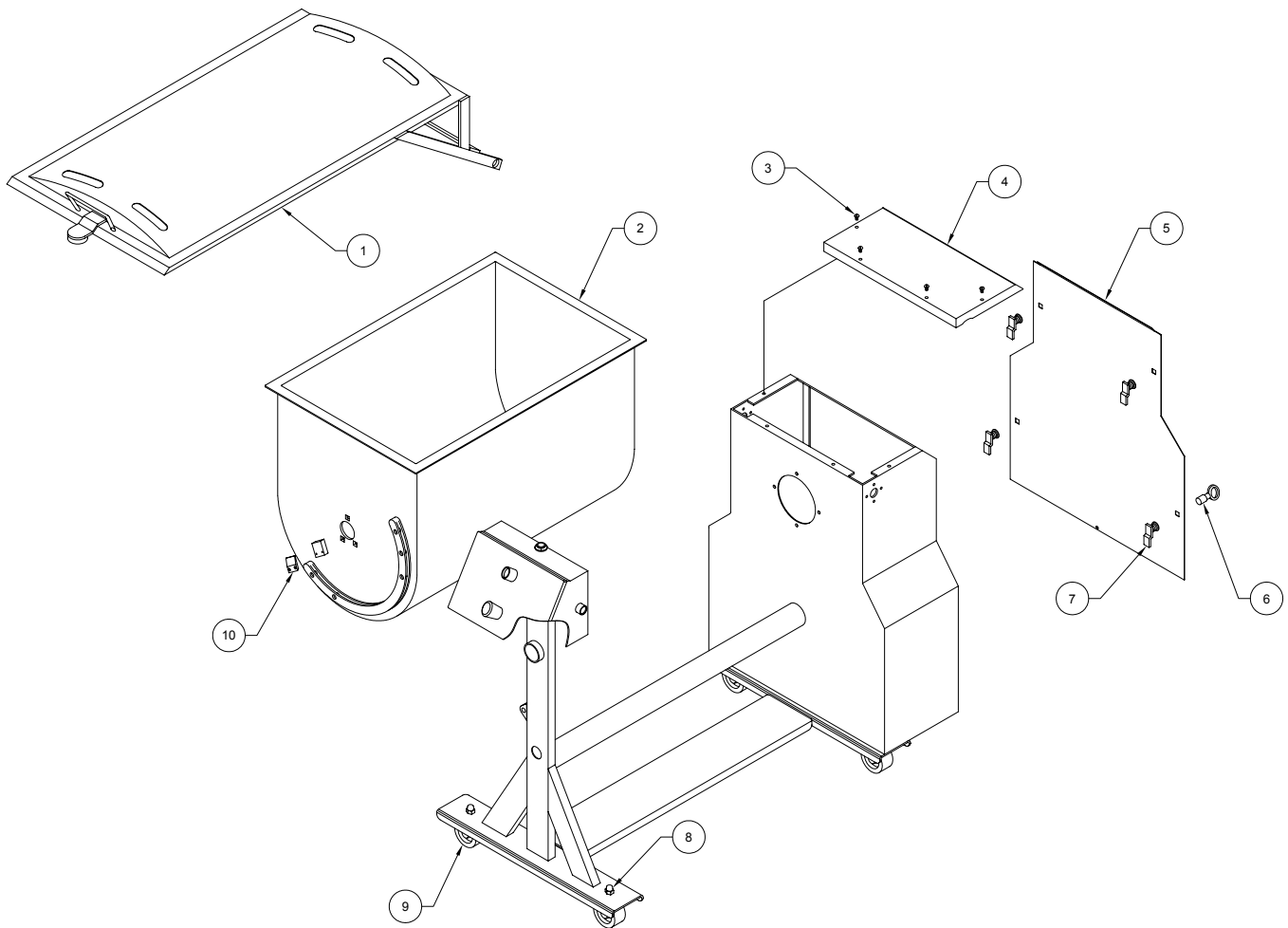

ITEM #	PART #	DESCRIPTION	QTY.
1	0025890	LID ASSEMBLY	1
2	0025935	TUB ASSEMBLY	1
3	THSS-19-04-SS	SCREW	4
4	0025929	TOP COVER	1
5	0025924	BACK COVER	1
6	0095773	KEY	1
7	0095772	LOCK	4
8	NA-27-SS	ACORN NUT	4
9	0095034	LOCKING CASTOR WHEEL	4
10	0025868	LIMIT SWITCH RAM	1

BUTCHER BOY 250 MIXER STAINLESS STEEL

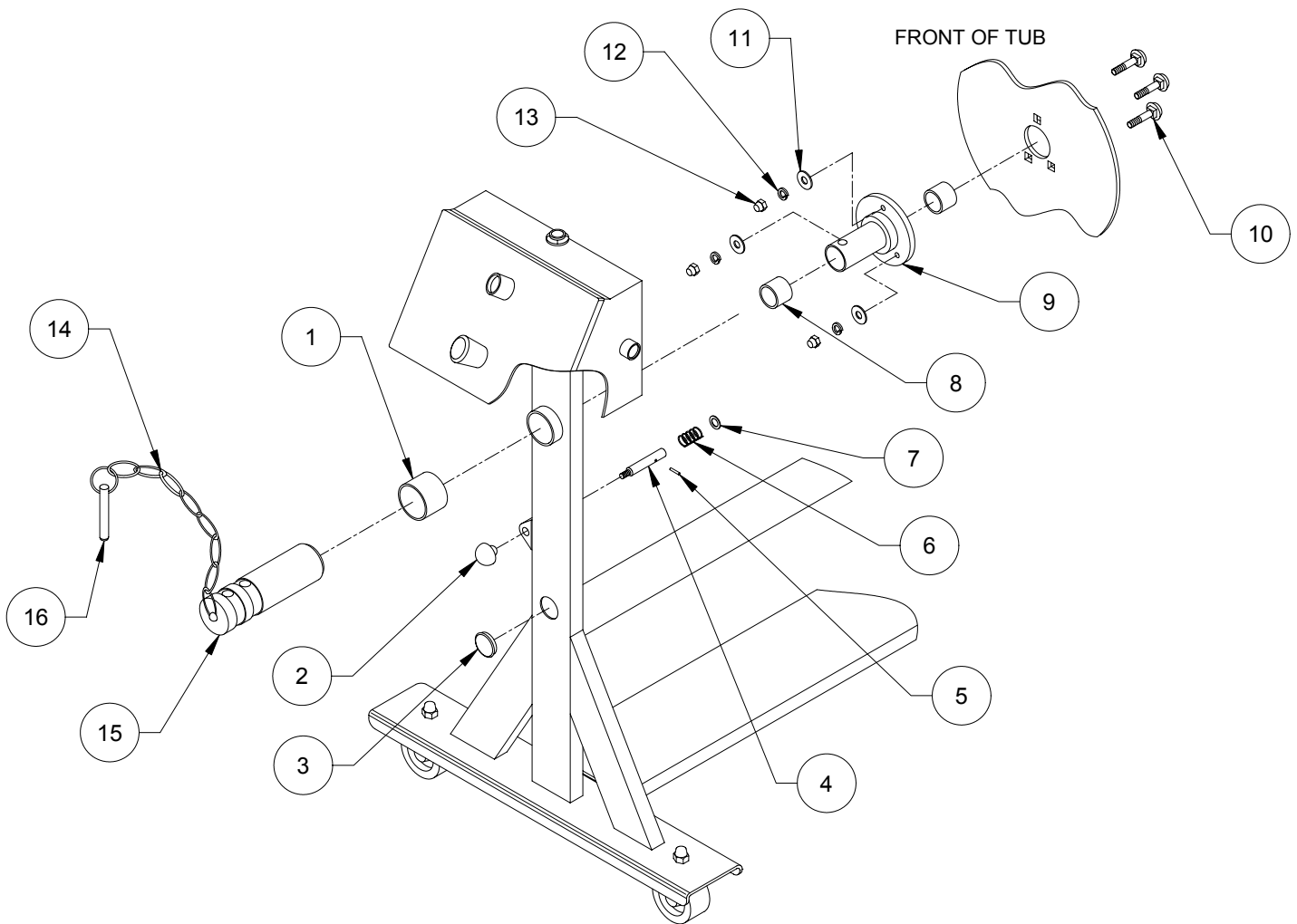

ITEM#	PART#	DESCRIPTION	QTY.
1	0025910	BUSHING	1
2	0090638	KNOB	1
3	0095695	PLUG	1
4	0026367S	TENSION PIN	1
5	GP-02-12-SS	PIN	1
6	0095789	SPRING	1
7	0025867	SPACER	1
8	0025911	INNER BUSHING	2
9	0025915	FRONT HUB	1
10	RHSN-2120-SS	CARRIAGE BOLT	3
11	FW-21-SS	FLAT WASHER	3
12	SLN-21-SS	LOCK WASHER	3
13	NA-21-SS	ACORN NUT	3
14	0090699-3	CHAIN	1
15	0025975	FRONT SHAFT	1
16	0095800	LOCKING PIN	1

BUTCHER BOY 250 MIXER STAINLESS STEEL

250 MIXER DRIVE COMPONENTS

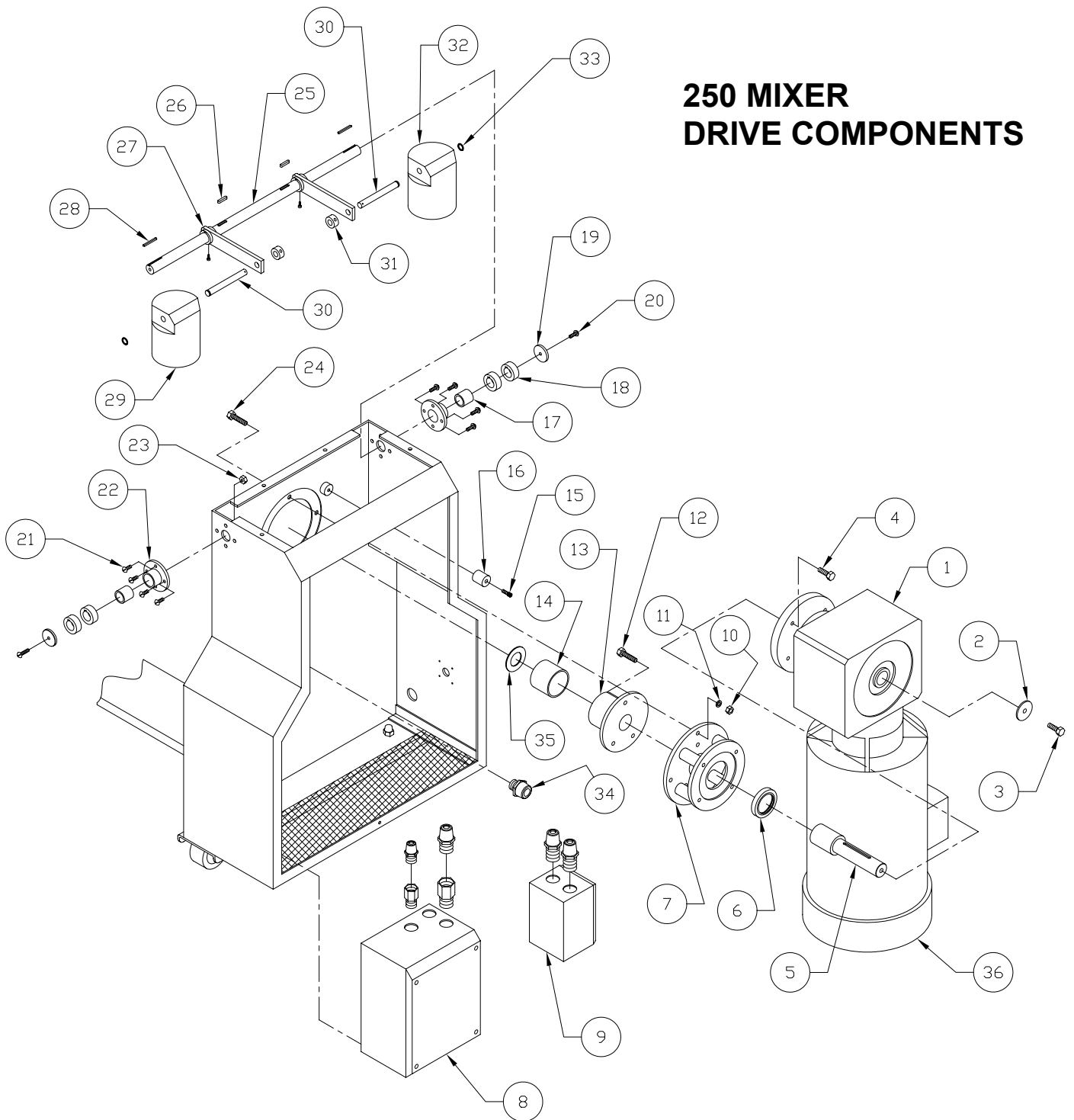

BUTCHER BOY 250 MIXER STAINLESS STEEL

ITEM#	PART#	DESCRIPTION	QTY.
1	0095803	GEARBOX REDUCER	1
2	0025947	END WASHER	1
3	HHCS-2314-SS	HEX HEAD SCREW	1
4	HHCS-2316-SS	HEX HEAD SCREW	1
5	0025918	GEAR BOX SHAFT	1
6	0090486	SEAL	1
7	0025950	GEARBOX PLATE	1
8	0093999-160	ENCLOSURE	1
9	0093999-239	ENCLOSURE	1
10	HNNI-21-SS	NYLOCK NUT	4
11	FW-05	FLAT WASHER	4
12	HHCS-2116-SS	HEX HEAD SCREW	4
13	0025980	FEMALE END	1
14	0025979	FEMALE BUSHING	1
15	SHCS-1916-SS	SOC HEAD SCREW	1
16	0095753	RUBBER STOP	1
17	0025690	BUSHING LID SHAFT	1
18	0095804	COLLAR	4
19	0025937	END PLATE	2
20	HHCS-19-08-SS	HEX HEAD SCREW	2
21	RHSS-19-14-SS	SLOT SCREW	8
22	0025913	BUSHING MOUNT	2
23	HN-NI-19-SS	NYLOCK NUT	8
24	HHCS-2116-SS	HEX HEAD SCREW	4
25	0025968	SHAFT LID	1
26	0059397-5	3/16 X 1" KEY	2
27	0025944	WEIGHT ARM	2
28	0059397-9	3/16 X 1.5" KEY	2
29	0025972	L.H. WEIGHT	1
30	0025967	WEIGHT SHAFT	2
31	0095018	WEIGHT COLLAR	2
32	0025971	R.H. WEIGHT	1
33	0090271	SNAP RING	2
34	0093999-131	3/4 STRAIN RELIEF	1
35	0025912	SPACER	1
36	0092075	BRAKE MOTOR 1.5 HP	1

BUTCHER BOY 250 MIXER STAINLESS STEEL

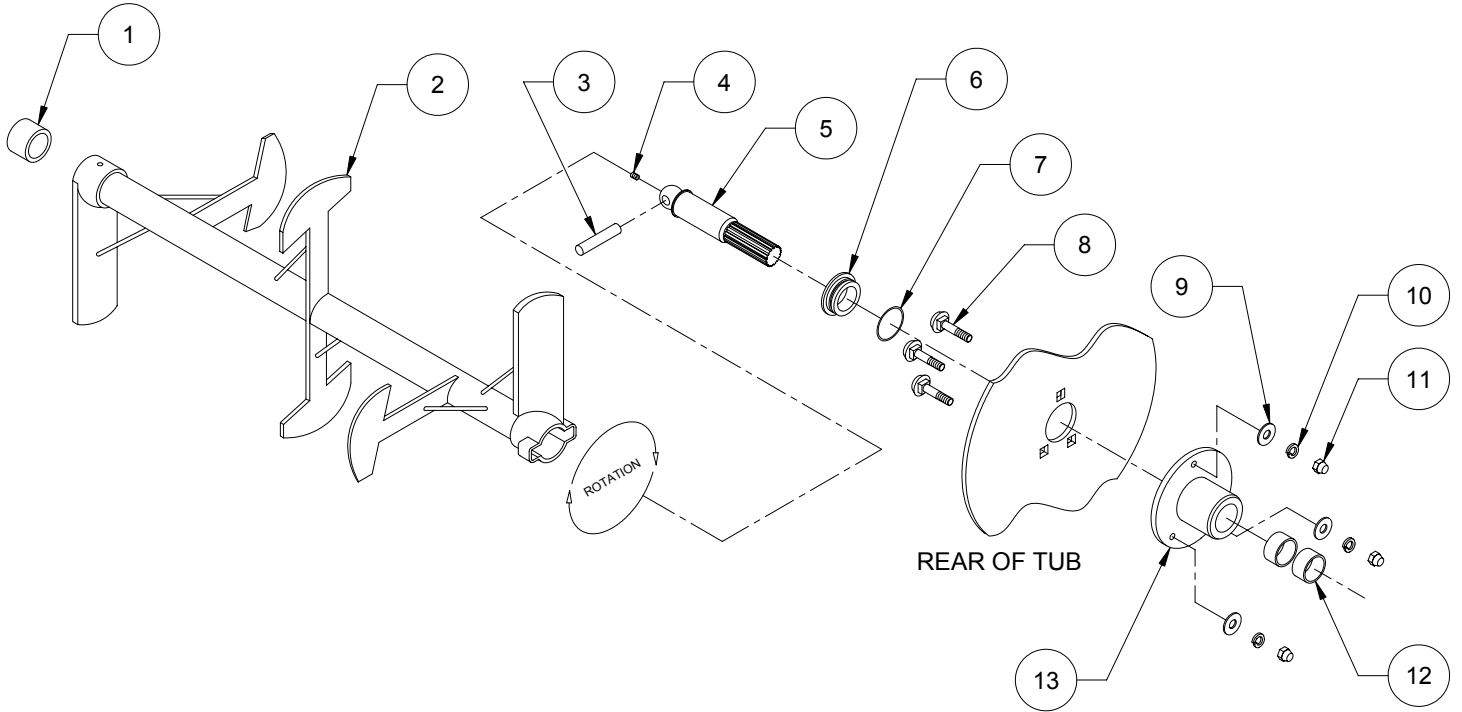

ITEM#	PART#	DESCRIPTION	QTY.
1	0026693	BUSHING PADDLE ASSEMBLY	1
2	0025820	PADDLE W/BUSHING R/H TILT	1
3	0045048	DRIVE PIN	1
4	SHSS-21-08-S	SET SCREW	1
5	0025945	SPLINE SHAFT	1
6	0025976	O-RING BUSHING	1
7	0050653	O-RING	1
8	RHSN-2120-S	CARRIAGE BOLT	3
9	FW-05-SS	FLAT WASHER	3
10	SLN-05-SS	LOCK WASHER	3
11	NA-21-SS	ACORN NUT	3
12	0025946	BUSHING SPLINE SHAFT	1
13	0025916	MALE HUB REAR	1

BUTCHER BOY 250 MIXER STAINLESS STEEL

250 MIXER CONTROL BOX COMPONENTS

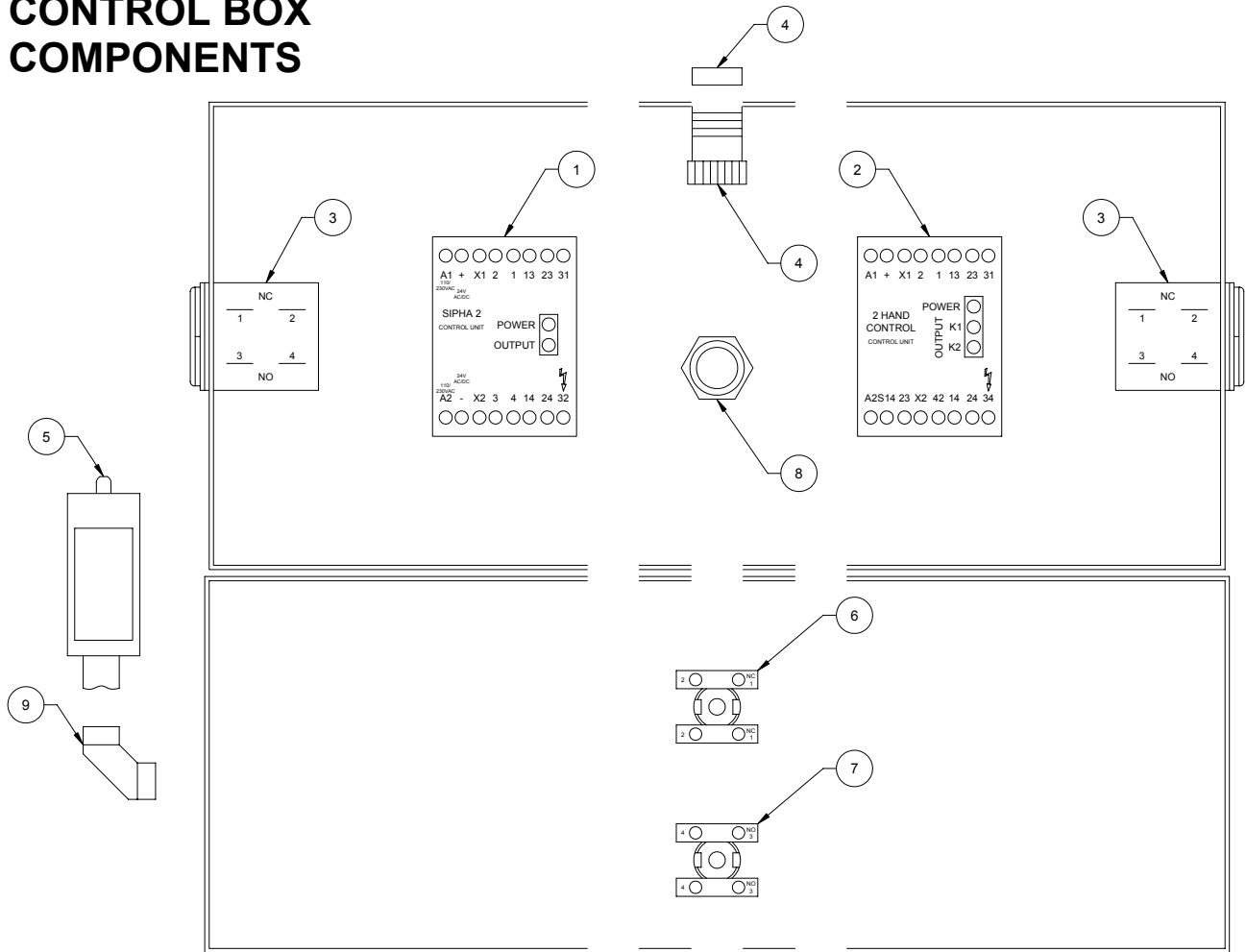

ITEM #	PART #	DESCRIPTION	QTY.
1	0093999-205	CONTROL UNIT	1
2	0093999-206	LOGIC UNIT	1
3	0093999-208	TWO HAND START BUTTON	2
4	0093999-207	SENSOR & ACTUATOR SET	1
5	0093271	SAFETY LIMIT SWITCH	1
6	0093999-209	STOP BUTTON ASSEMBLY	1
7	0093999-210	START BUTTON ASSEMBLY	1
8	0095796	STRAIN RELIEF	1
9	0095795	ELBOW FITTING	1

BUTCHER BOY 250 MIXER STAINLESS STEEL

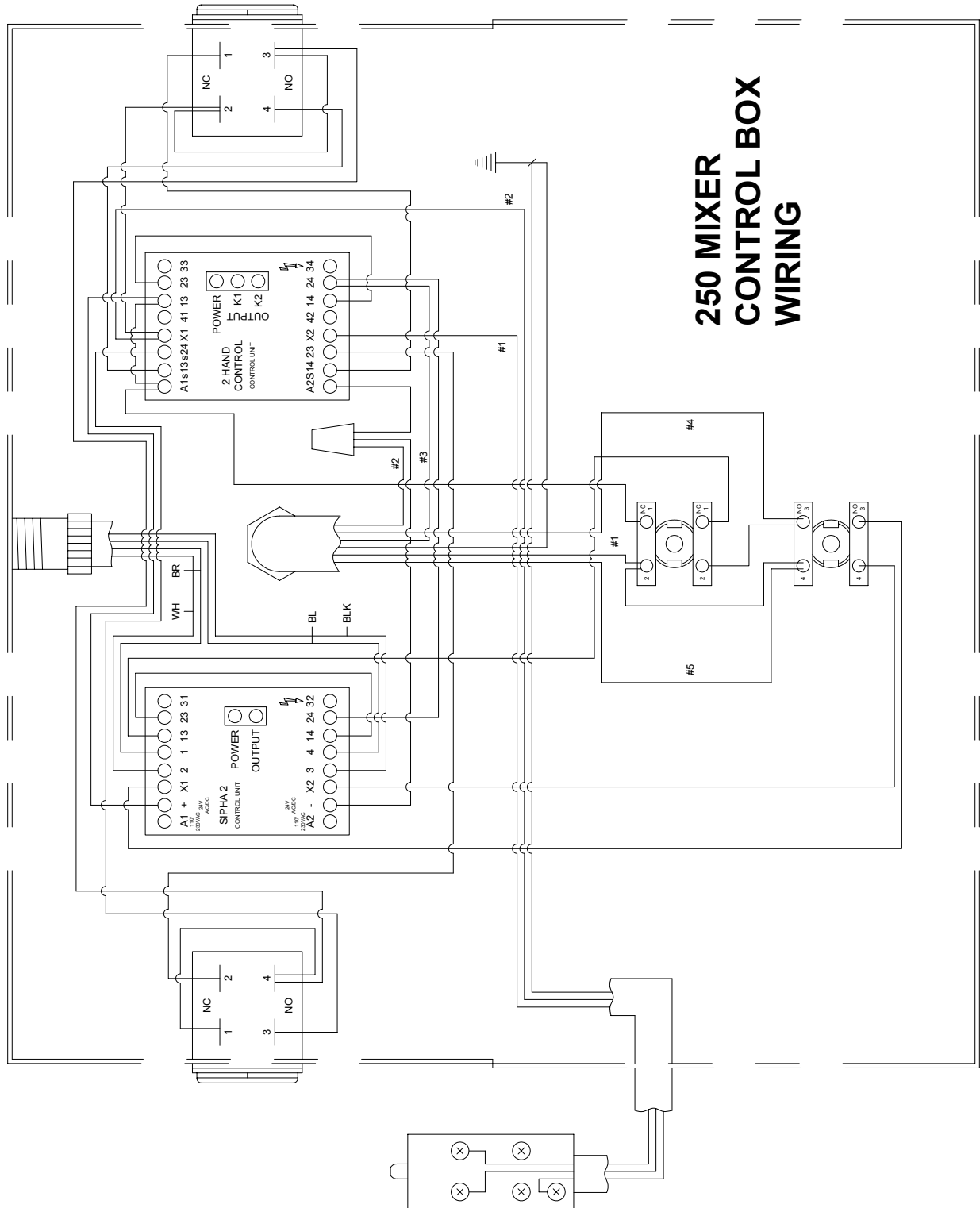

BUTCHER BOY 250 MIXER STAINLESS STEEL

250 MIXER ELECTICAL COMPONENTS

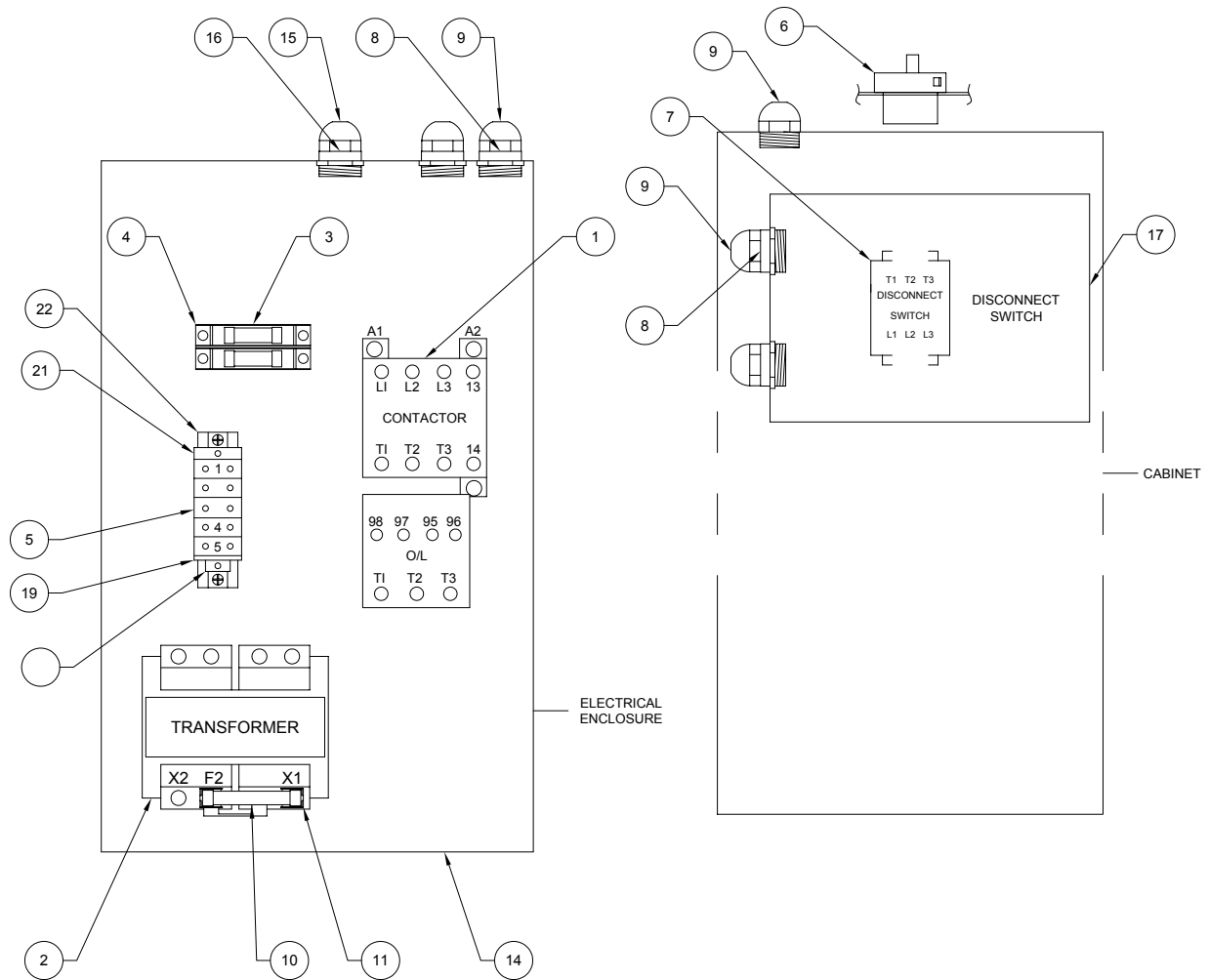

ITEM #	PART #	DESCRIPTION	QTY.
1	0093999-110	STARTER (460-575V)	1
2	0093999-095	TRANSFORMER (208-460/24V)	1
3	0093999-025	F1 .30A FUSE (230V)	2
4	0093999-024	FUSE HOLDER (PRIMARY)	1
5	0093999-070	TERMINAL BLOCKS	5
6	0093999-055	DISCONNECT HANDLE	1
7	0093999-023	DISCONNECT SWITCH	1
8	0093999-180	3/4" WATER TIGHT HUB	3
9	0093999-131	3/4" STRAIN RELIEFE	4
10	0093999-018	2.8A FUSE	1
11	0093999-096	FUSE CLIP	1
14	0093999-160	ENCLOSURE	1
15	0093999-132	1/2" STRAIN RELIEF	1
16	0095769	1/2" WATER TIGHT HUB	1
17	0093999-239	DISCONNECT ENCLOSURE	1
19	0093999-069	END SECTION TERMINAL	1
20	0093999-187	END TERMINAL	2
21	0093999-072	GROUND TERMINAL	1
22	0093999-077	TERMINAL RAIL	1

BUTCHER BOY 250 MIXER STAINLESS STEEL

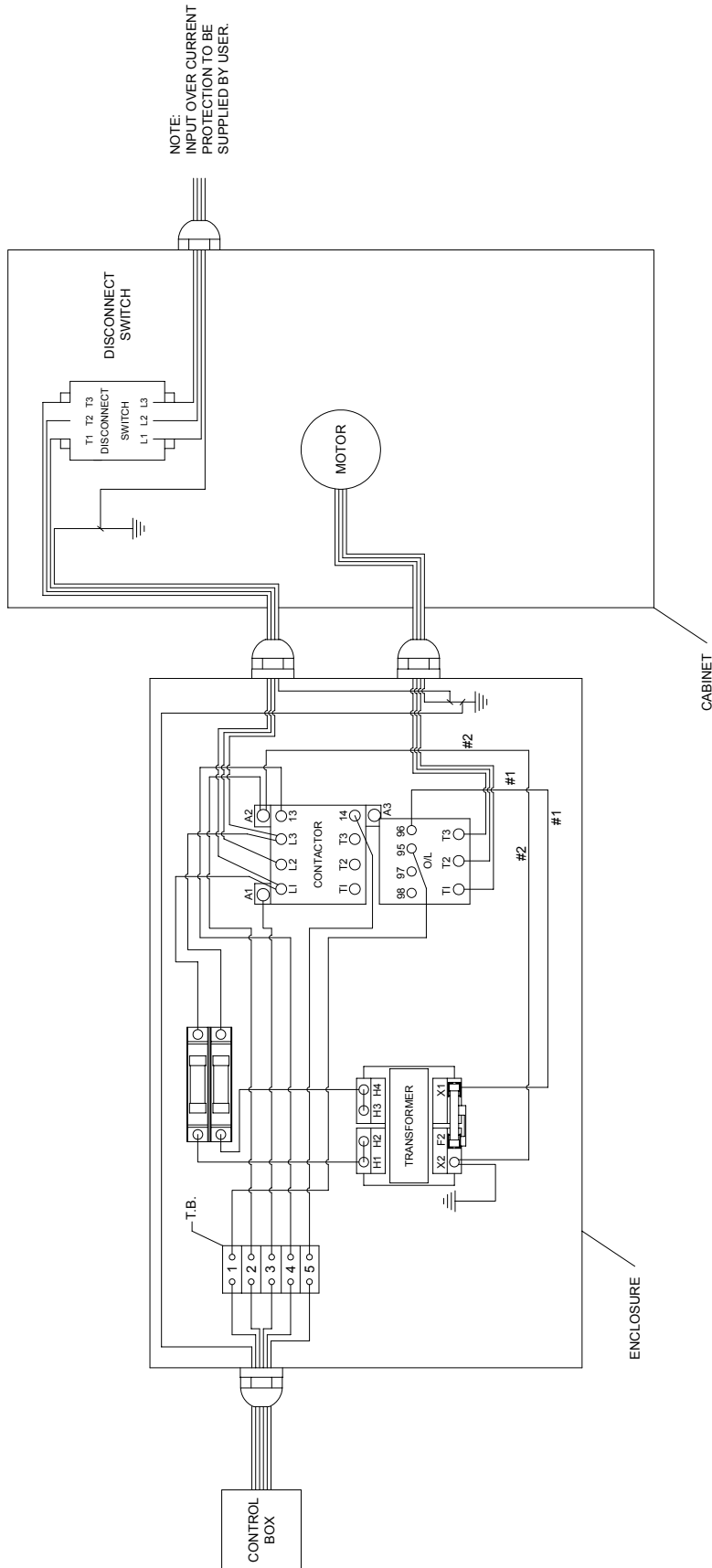

NOTE:
INPUT OVER CURRENT
PROTECTION TO BE
SUPPLIED BY USER.

**250 MIXER
230vac WIRING
ENCLOSURE BOX**

BUTCHER BOY 250 MIXER STAINLESS STEEL

NOTE:
INPUT OVER CURRENT
PROTECTION TO BE
SUPPLIED BY USER.

INPUT VOLTAGE
230V 3Ø

