

Thank you for your business!

We trust you will find this new Marinator to be efficient and durable.

Please return this completed page. The owner is required to return this product registration information immediately.

The model and serial numbers are stamped on the nameplate located next to the machine's controls. Please print clearly.

-----Second Fold Line-----

Place
stamp
here

AyrKing Corporation
2013 Cobalt Drive
Louisville, KY 40299-2417
USA

-----First Fold Line-----Seal with tape-----Do not staple-----

Store Name: _____ Store I.D.#: _____

Address: _____

City: _____ State/Province/Region: _____

Country: _____ Postal Code: _____

Telephone: _____ Fax: _____

Store Owner: _____

Model: _____ Serial Number: _____

This page intentionally left blank.

AyrKing Corporation

2013 COBALT DRIVE
LOUISVILLE, KY 40299 USA
www.ayrking.com



TELEPHONE 1-502-266-6270
USA Toll free 1-866-266-6290
FACSIMILE 1-502-266-6274

Tumble Marinator

Operation, Maintenance, Warranty

M-101

Read this manual thoroughly before operating machine.
The model and serial numbers are on the data plate mounted on the machine.
Record the model and serial numbers below.
Refer to these numbers in any correspondence with AyrKing Corporation.

Model _____

Serial Number _____

Note: All procedures listed on these pages are general use guidelines.

Please refer to your company procedures for exact instructions.

IMPORTANT SAFETY INSTRUCTIONS

Read all instructions before operating. When using electrical appliances, basic safety precautions must be followed. Use this appliance only for its intended use as described in this manual. Verify that appliance is properly installed and electrically grounded by a qualified technician in accordance with local electrical codes. Do not attempt to repair or replace electrical components. A qualified technician should complete all servicing to these components. Before performing any service, disconnect the machine's power supply. Never wear loose-fitting or hanging garments while using any appliance. Ties, necklaces, etc. may catch on moving parts possibly causing injury.

CAUTION - Risk of fire and/or electrical shock. Replace only with manufacturer's cord set:

DO NOT SPRAY MACHINE WITH WATER

Machine is designed to shed water & dust;
however, **IT IS NOT WATER PROOF.**

INITIAL SETUP

1. Plug in unit.
2. The marinator comes pre-set from the factory for the tumble cycle time. If this time needs to be adjusted, the access panel in front of the timer can be removed. The timer is located to the right of the start and stop switches.
3. The timer for the marinating cycle will be set for 2 minutes 0 seconds or some other time period. For example at 2 minutes, the timer relay display would read “0”, “2”, “0”, “0”. The 0200 setting causes the drum to tumble for 2 minutes 0 seconds. The two numbers to the left of the center letter represent minutes. The two numbers to the right represent seconds. The white buttons on the top and bottom of each digit in the timer relay will change each individual setting. Set the timer to desired operation time.
4. Attach the stainless steel access panel after timer adjustment.

OPERATION

If anything seems unusual during the tumbling process, press the red stop-button to terminate operation.

1. Open the lid of the drum. Put the raw protein pieces and marinating solution into the drum.
2. Make sure the gasket is in place. Close the lid of the drum. Rotate the handle so the inside latch keeps the lid from coming off. Lock the lid in place by rotating the cam handle down toward the drum cap. Make sure a portion of the top gasket is visible to ensure a good seal with the lid.
3. Press the marinating cycle button to start the rotation of the drum.
4. The drum stops rotating after the preset time has expired. Marinating is now complete.
5. Place an unloading pan onto the lower shelf and take the lid off the drum. Manually rotate drum so that marinated food pours out slowly into pan.

MAINTENANCE

1. At the end of the day, remove the drum for cleaning. Wash thoroughly in a sink with soap and water. Make sure the gasket is cleaned. After the parts have dried, put the machine back together.
2. Check the gasket each month, replace if damaged.
3. Once a year the machine should be thoroughly inspected. Any damaged components should be replaced.

PROBLEM SOLVING GUIDE

Problem #1: Marinator will not operate. No response if start button is pressed.

Solution:

- A. Make sure unit is plugged into power source. Make sure power source is supplying power. Check if the stop-button is locked in place. If yes, turn the button clockwise to unlock.
- B. Check if the fuse is blown, replace if needed.
- C. Check if the relay is damaged. If yes, contact a repair technician.

Problem #2: The Marinator is too noisy.

Solution:

Oil the gear and bearing.

PARTS VIEW

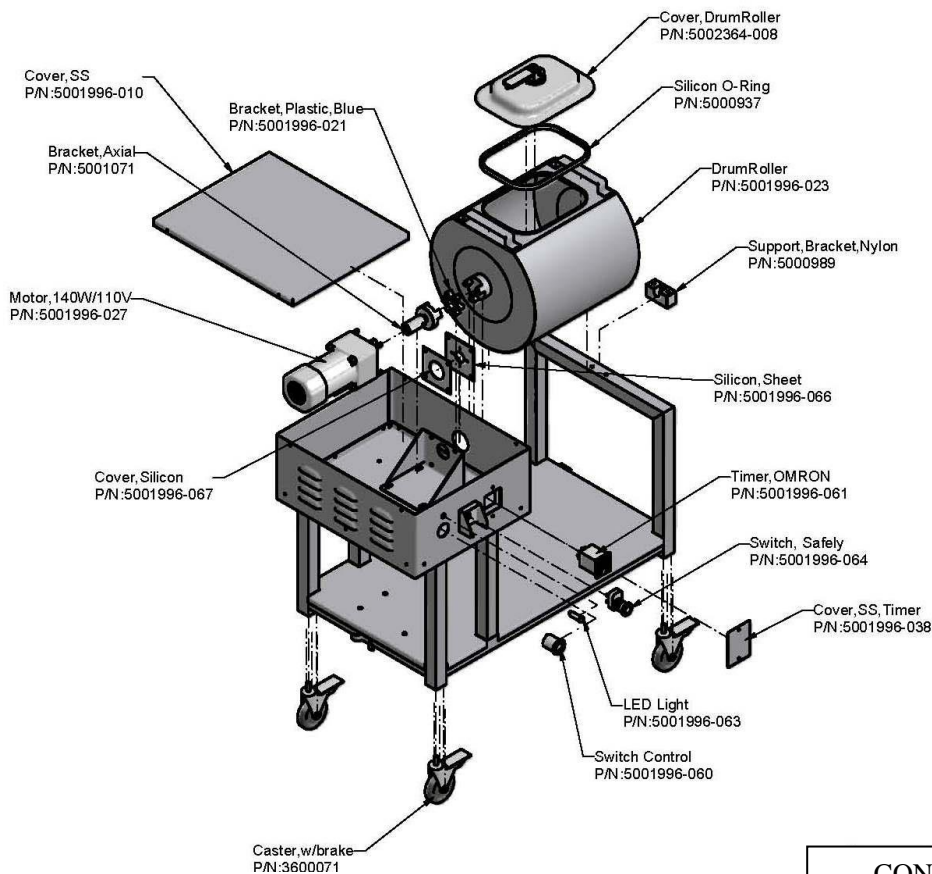

Parts List				
IT	QT	PART NO.	TITLE	
82	24	3100002-1	Screw, M4*10, SS, Round Head	
83	24	3210011	Washer, M4, SS	
84	1	3530010	Power wire, E114235)	
85	4	3204042	Nut, M8, SS	
86	4	3210031	Washer, M8, SS	
87	4	3150059	Screw, M8*16, SS, Hex Head	

CONTACT AYR KING FOR ASSISTANCE
1-502-266-6270

TERMS AND CONDITIONS

DAMAGED SHIPMENTS

Notify carrier in event of damaged shipments, whether apparent at time of delivery or concealed damage discovered after unpacking. File complaint with the carrier as the customer will be responsible for collection of damage claims. AyrKing retains no liability for damaged goods once the goods ship from our dock.

RETURNS

No returns will be accepted without written approval from AyrKing. All returned shipments must be freight prepaid and are subject to handling or re-stocking charges.

WARRANTY

AyrKing Corporation warrants that the AyrKing Marinator shall be free from original defects in workmanship and material provided the same has been properly stored, installed, serviced, maintained, and operated. AyrKing Corporation extends this warranty to the original purchaser only. This warranty specifically covers the mechanical and electrical components that constitute the drive system of the machine.

This warranty provides non-prorated replacement of defect components and labor coverage. This warranty begins on the date of initial use or 60 days from the date of shipment from our factory, whichever occurs first. The parts warranty is in effect for the period of 12 months. The labor warranty is in effect for the period of 90 days.

The end user is required to register ownership of this product with AyrKing Corporation by returning the warranty card supplied with the machine. This warranty shall be null and void if the product is not immediately registered with AyrKing Corporation.

Notify AyrKing Corporation of any performance failure. Specify model and serial number of the product when contacting AyrKing. AyrKing personnel will assist in evaluating the cause of failure, ship any necessary replacement components, and authorize a service agency call. Replacement components will be provided and shipped at no cost (via least expensive route) to the end user provided that the end user returns the defective component within two weeks (if required by AyrKing). AyrKing reserves the right to test and evaluate the failed component to determine whether the failure is covered by this warranty. If AyrKing does not receive defective components within two weeks of replacement component shipment (if required by AyrKing) or if the failure is determined not to be covered under this warranty, AyrKing will invoice the end user for the replacement component, shipping costs, and labor charges if applicable.

AyrKing Corporation is not responsible for any damages due to removal or any expenses incurred for installation of replacement component including but not limited to travel time, fuel charges, etc. AyrKing Corporation is not liable for any other expenses or costs due to the non-performance of the product including shipping costs on the mandatory return of defective product or component. The buyer assumes all risks and liability for results of use of product. This warranty does not apply to products that have been misused, subjected to negligence or accident, or altered/repared in any way so as to affect the product's performance or reliability. This warranty does not apply to any peripheral components such as lugs, plugs, pans, pots, baskets, or other items that may be bundled in a package with the Marinator.