



Thank you for your business!

We trust you will find this new
Drumroll Autobreader
to be quiet, efficient, and durable.

**Please return this completed page.
The owner is required to return this product
registration information immediately.**

The model and serial numbers are stamped on the nameplate
located next to the machine's controls.
Double sifter tables have two different serial
numbers - please list both. Please print clearly.

-----Second Fold Line-----

Place
stamp
here

AyrKing Corporation
2013 Cobalt Drive
Louisville, KY 40299-2417
USA

-----First Fold Line-----Seal with tape-----Do not staple-----

Store Name: _____ Store I.D.#: _____

Address: _____

City: _____ State/Province/Region: _____

Country: _____ Postal Code: _____

Telephone: _____ Fax: _____

Store Owner: _____

Model: _____ Serial Number(s): _____

This page intentionally left blank.



DRUMROLL

Operation, Maintenance, and Warranty

for Model Numbers beginning with:
DR (For example DR-UF-120)



Read this manual thoroughly before operating machine.
The model and serial numbers are on the data plate mounted on the machine.
Record the model and serial numbers below.
Breeding tables with two machines will have two serial numbers.
Refer to these numbers in any correspondence with AyrKing Corporation.

Model _____

Serial Number(s) _____

Note: All procedures listed on these pages are general use guidelines.
Please refer to your company procedures for exact instructions.

IMPORTANT SAFETY INSTRUCTIONS

Read all instructions before operating. When using electrical appliances, basic safety precautions must be followed. Use this appliance only for its intended use as described in this manual. Verify that appliance is properly installed and electrically grounded by a qualified technician in accordance with local electrical codes. Do not attempt to repair or replace electrical components. A qualified technician should complete all servicing to these components. Before performing any service, disconnect the machine's power supply. Never wear loose-fitting or hanging garments while using any appliance. Ties, necklaces, etc. may catch on moving parts...possibly causing injury.

CAUTION - Risk of fire and/or electrical shock. Replace only with manufacturer's cord set:
120 volt unit uses part number [B319](#)
240 volt unit uses part number [B419](#)

DO NOT SPRAY MACHINE WITH WATER

Machine is designed to shed water & dust; however, **IT IS NOT WATER PROOF.**



OPERATION

(Numbers in parenthesis refer to parts view drawings)

ASSEMBLY:

- Begin each day with all components clean and thoroughly dry.
- Place drum drive base (1) on table top to the side of the plastic lug. If using funnel pan place drum over top of funnel pan.
- Install rubber drive bands (27) between metal groves on drum (18). Push plastic end cap (20) on end of drum, then flip over. When installing caps, take care to press evenly all the way around the cylinder, to insure a good seal.
- Install wire frame (19) inside drum (18), twist while pushing down.
- Install second end cap (20) on opposite end using same procedure as above.
- Install silicone magnetic door (21) aligning within the opening in drum.
- Place fully assembled drum (18) on drive base (1) with the end with the notched wire frame facing the side the product will exit.
- Install loading chute frame (22) in grommets on loading end, slide loading chute (22) over frame making sure hook clips over end of loading frame.
- Install exit ramp (23) in grommets on unloading side of drum. NOTE: dust guard on underneath side of ramp must be inside the drum.
- Install return chute (24) on base over top of level.

AUTOBREADING:

- Using aluminum scoop load breading into drum (8) by first removing the magnetic silicone door (21) to access inside of drum. Load breading into drum until the level is just below the hole in the plastic end caps (20).
- Load raw product onto loading chute (22) allowing product to enter the drum (18).
- Product will pass through the breading in the drum working its way to the opposite end which it will then make its way down the exit ramp (23) and into the basket to then be rocked to remove any excess breading.
- Continually add breading to drum as needed utilizing steps above.



DAILY CLEANING

(Numbers in parenthesis refer to parts view drawings)

- Always disconnect power supply when servicing or cleaning machine. **NEVER SPRAY MOTOR COMPARTMENT WITH WATER.**
- Remove loading ramp (22), exit ramp (23), and return chute (24). Take all items to wash sink.
- Disassemble drum (18) in reverse order of steps seen in the assembly section of “Operation”. Take all items to wash sink.
- Coating basket and aluminum scoop can both be taken to wash sink to be cleaned.
- Clean motor drive base (1) with a towel soaked in detergent/water solution. Be sure to clean all crevices. Wipe off soapy solution using water rinsed towel until all surfaces are clean. Soak towel in sanitizing solution (or bleach/water solution) and wipe all surfaces thoroughly.
- In wash sink, spray all removed items with hose to dislodge any breadding. Soak all components in dish washing detergent and water solution.
- Place items upside down on tabletop to air-dry. Allow all components to thoroughly dry before reusing.

DR PARTS VIEW

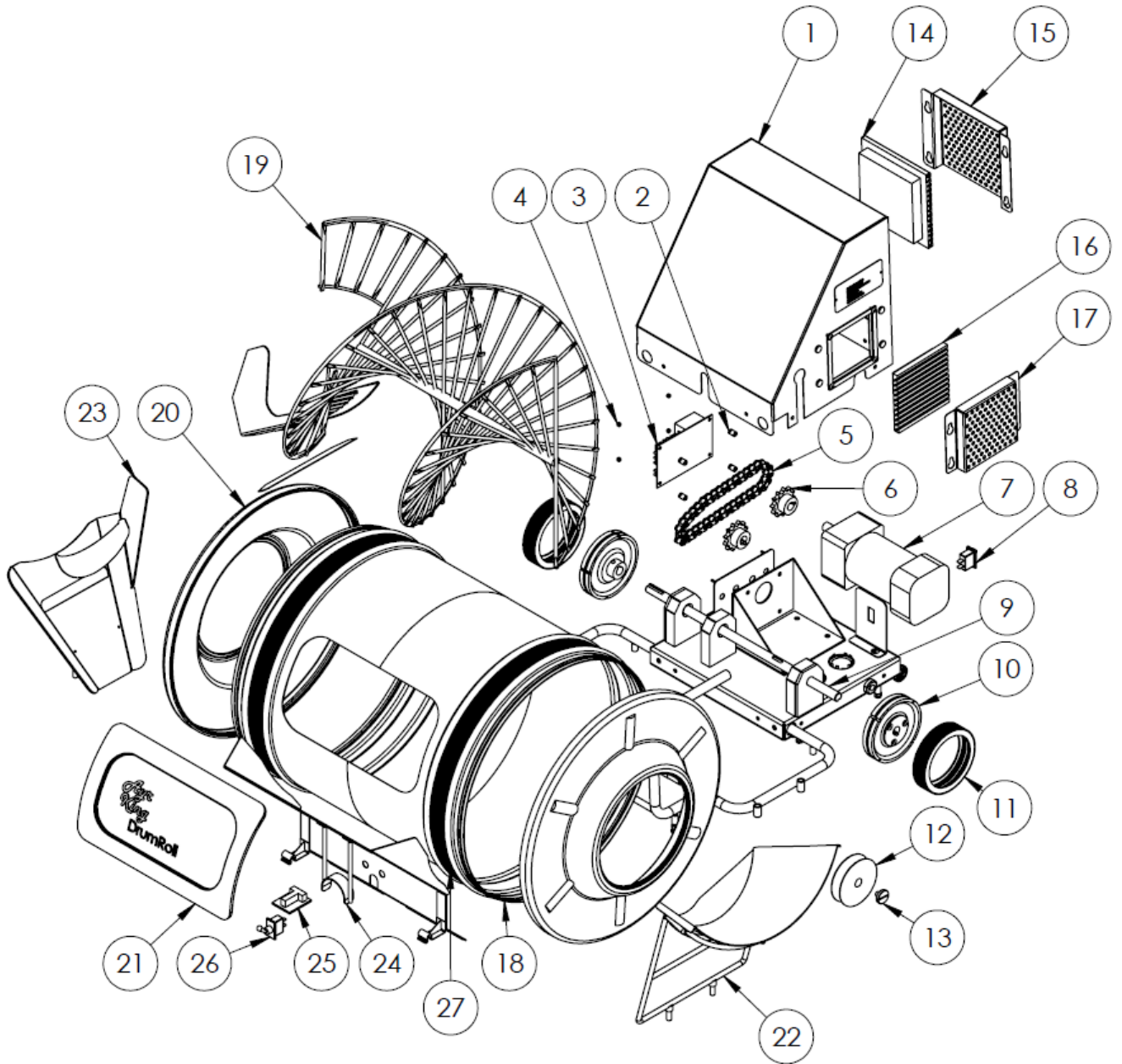



DR PARTS LIST

EACH ITEM HAS DIFFERENT PART NUMBERS DEPENDING ON THE SIFTER MODEL

ITEM	PART #	DESCRIPTION [NOMINAL SIZE]
1	DR110	DR MOTOR COMPARTMENT FAN HOUSING
2	B532	NYLON WASHER/SPACER SET
3	DR102	DR TIMER BOARD
4	B533	SET OF 4 NUTS FOR B530
5	DR318	DR CHAIN
6	DR319	DR SPROCKET
7	DR116	DR DRIVE MOTOR
8	A109	DR FLOW TOGGLE SWITCH
9	DR320	DR DRIVE AXLE AND SUPPORTS
10	DR302	DR DRIVE WHEEL ASSEMBLY
11	DR304	RUBBER DRIVE WHEEL COVER
12	DR111	GUIDE WHEEL, NON-BEARING
13	DR309S	DR BEARING WHEEL SCREW
14	DR138	REAR FAN PLASTIC COVER
15	DR137	SS REAR EXTERIOR FAN FILTER COVER
16	DR141	SIDE PLASTIC COVER
17	DR140	SS SIDE EXTERIOR MOTOR FILTER COVER
18	DR200	DR DRUM ASSEMBLY
19	DR202SLF	DR DNA WITH CENTER SHAFT
20	DR201GROOVE	DR DRUM END CAP
21	DR205	MAGNETIC SILICONE DOOR
22	DR104	DR BREADING RAMP AND FRAME
23	DR105	DR BREADING EXIT RAMP
24	DR103	DR BREADING RETURN CHUTE
25	DR107	DR BASE LEVEL
26	3530015	ON/OFF SWITCH
27	DR204	RUBBER DRIVE BAND FOR DRUM

Parts: <https://parts.ayrking.com/>

DR GENERAL PARTS & ACCESSORIES

EACH ITEM HAS DIFFERENT PART NUMBERS DEPENDING ON THE SIFTER MODEL

DR139	REAR FAN FILTER
DR142	SIDE MOTOR FILTER
DR143	DR EXHAUST FAN



PROBLEM SOLVING GUIDE

Many problems have a simple solution. Please use this guide to help resolve operational difficulties. Contact AyrKing Corporation if unable to correct any problem.

PROBLEM

POSSIBLE SOLUTIONS

Drumroll not turning.

Turn the drumroll manually. If the drumroll won't spin, check the voltage of the timer board and motor to determine if both are receiving power. If the drumroll turns manually, try to spin the drum in the opposite direction. If the drumroll turns, it is likely the timer board. If it will not turn the opposite direction, it may be a bad capacitor.

Dusting in drumroll housing

Check filters and housing to ensure no dusting from the breading has gotten into the unit. Clean out any dusting and check silicone seal on the bottom of the housing to prevent this problem from reoccurring. Occasionally check and clean the filter as often as needed, based on the continuous usage of the drumroll.

<https://www.ayrking.com/maintenance/>

ELECTRICAL SCHEMATICS

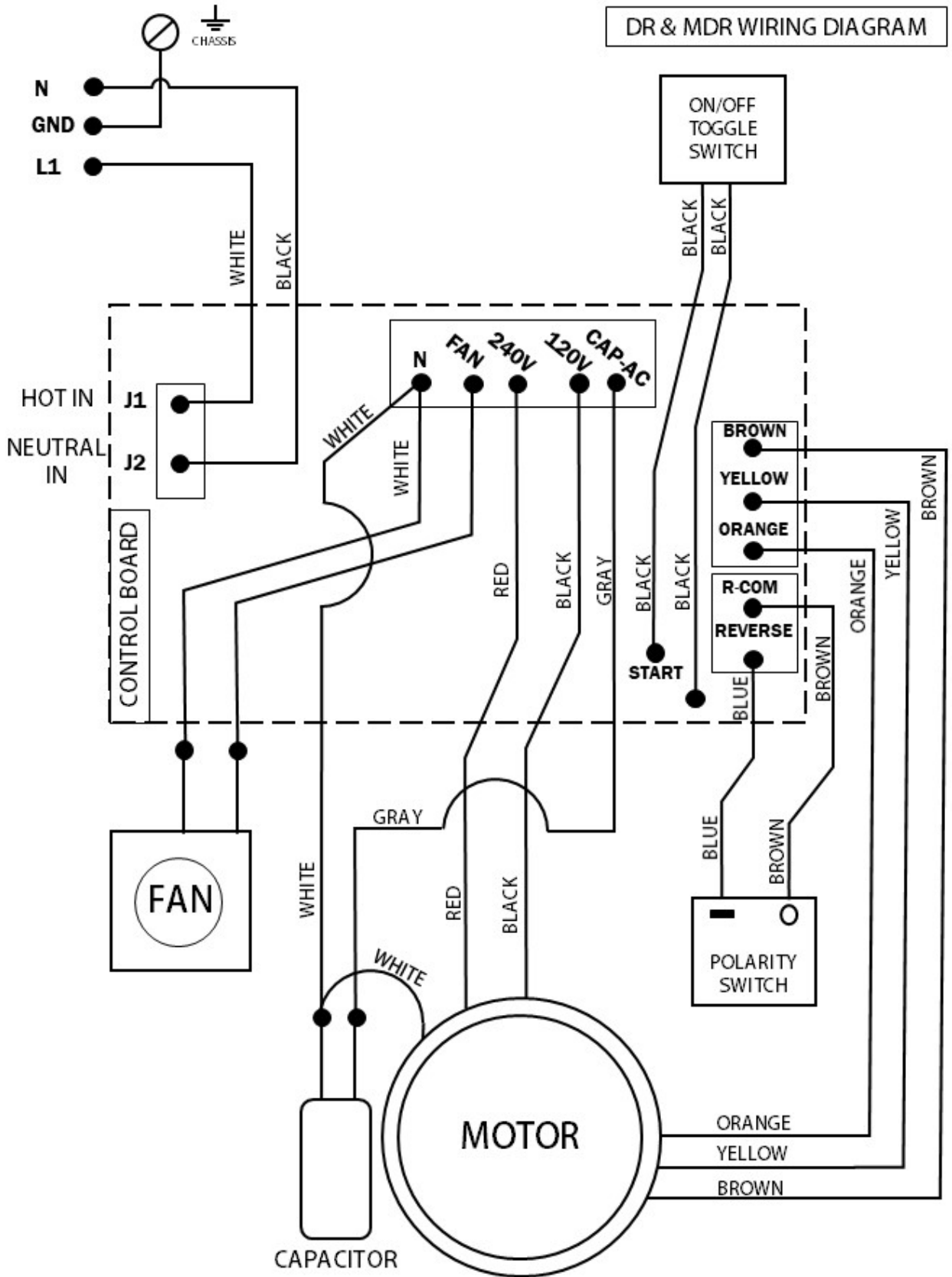



TERMS AND CONDITIONS

Description

This warranty is in effect for AyrKing equipment used within North America. See the International Claims section for warranty claims outside of North America. AyrKing warrants that the AyrKing equipment shall be free from original defects in workmanship and material, provided the equipment has been properly stored, installed, serviced, maintained, and operated. AyrKing extends this warranty to the original purchaser only. This warranty specifically covers the mechanical and electrical components for our equipment.

Registration

The end user must register ownership of their equipment with AyrKing Corporation by returning the warranty card supplied with the machine or registering their equipment on the AyrKing website at <https://www.ayrking.com>.

Coverage

This warranty provides non-prorated replacement of defective components and labor coverage. This warranty begins on the date of first use or 60 days (about 2 months) from the date of shipment from AyrKing's warehouses, whichever occurs first unless proof of installation can be provided. **The parts warranty is in effect for 12 months. The labor warranty is in effect for 90 days (about 3 months).**

The manufacturer's obligation under this warranty shall be the replacement or repair of defective parts within the warranty period. Excessive labor (more than 1/2 hour) required to access AyrKing equipment built into cabinets, tables, or structures by others, is NOT covered under this labor warranty. All labor shall be performed during regular working hours. AyrKing will not reimburse overtime premiums.

If, upon inspection, it is determined that this AyrKing equipment has not been properly installed, used appropriately, modified or maintained, the warranty will be void. If the equipment has been subjected to misuse or misapplication, neglect, abuse, accident, damage during transit or delivery, fire, flood, riot or acts of God, then this warranty shall also be void. When any situation occurs which voids the warranty then AyrKing shall not be liable for any damage to any person or any property which may result from the use of the equipment thereafter. The warranty is limited to AyrKing manufactured equipment only and does not apply to other equipment which may be connected to or installed within.

Claims

Notify AyrKing of any performance failure (1-502-266-6270). Specify model and serial number of the equipment when contacting AyrKing. AyrKing personnel will help in evaluating the cause of failure, ship any necessary replacement components, and authorize a service agency call if applicable. Replacement components will be supplied and shipped at no cost (via least expensive route) to the end user if they return the defective part within two weeks (if required by AyrKing). AyrKing reserves the right to test and evaluate the failed part to determine whether the failure is covered by this warranty. If AyrKing does not receive defective components within two weeks of replacement part shipment (if required by AyrKing) or if the failure is determined not to be covered under this warranty, AyrKing will invoice the end user for the replacement part, shipping costs, and labor charges if applicable.

****AyrKing will reimburse up to 1 Hour of labor charges. Contact AyrKing tech support for approval if any repair will take over 1 hour to complete.** 502-266-6270 Tech Support

****AyrKing reserves the right to deny all labor (time) charges considered excessive for any repair.**

****AyrKing will not reimburse the cost of warranty parts bought from other vendors or parts suppliers.**

International Claims

Please contact your kitchen equipment supplier to process warranty claims. AyrKing will reimburse the supplier for warranty repairs. The parts warranty is in effect for 12 months. The labor warranty is in effect for 90 days.



TERMS AND CONDITIONS (CONTINUED)

Missing or damaged Items

Claims of items missing from a shipment or damaged in transit must be reported within five (5) business days of receipt of the merchandise. Anytime you receive items, please take some time to carefully inspect the equipment. Each shipment will include a packing label on the box. Please verify the receipt of all items listed on the packing label.

Order Cancellation

- **Unshipped Order:** If the order is still open in AyrKing's system, please contact AyrKing's customer care team to cancel the order. The customer may not be charged any shipping or restocking fees if the order has not been prepared or shipped.
- **Shipped Order:** If the customer order has already shipped, the customer may refuse the shipment when it arrives, or the customer can accept the order and start a return authorization through AyrKing's returns process. When a shipment is refused, it will come back to AyrKing's warehouse, and the customer will be charged a restocking fee and any shipping fees associated with the return.
- **Received Order:** If the customer already received their purchased item(s), the customer must contact AyrKing's customer appreciation team to start a return. The customer will be provided with a return authorization number and instructions on how to ship their items back.

Standard Returns

Unused, regularly stocked items may be returned by contacting AyrKing's customer relations team within **90 days (about 3 months)** of the invoice date. A representative will create a return authorization and provide further instructions for completing the return process. Each return is subject to a 20 percent restocking fee which will be deducted from the refund amount. The customer will also be responsible for securing a shipping agent to return the merchandise, plus all shipping fees incurred.

Restocking Fees

There are many costs involved in processing a return. AyrKing charges a 20 percent restocking fee for all items returned.