

Seal with tape. Do not staple.

Thank you for your business!

We trust you will find this new
DrumRoll Automated Breader
to be valuable, efficient, and durable.

**Please return this completed page.
The owner is required to return this product
registration information immediately.**

The model and serial numbers are stamped on the nameplate
Please print clearly.

-----Second Fold Line-----

Place
stamp
here

AyrKing Corporation
2013 Cobalt Drive
Louisville, KY 40299-2417
USA

-----First Fold Line-----Seal with tape-----Do not staple-----

Store Name: _____ Store I.D.#: _____

Address: _____

City: _____ State/Province/Region: _____

Country: _____ Postal Code: _____

Telephone: _____ Fax: _____

Store Owner: _____

Model: _____ Serial Number(s): _____

This page intentionally left blank.

AyrKing Corporation

2013 COBALT DRIVE
LOUISVILLE, KY 40299 USA
www.ayrking.com



TELEPHONE 1-502-266-6270
USA Toll free 1-866-266-6290
FACSIMILE 1-502-266-6274

DRUMROLL AUTOBREADER

Operation, Maintenance, and Warranty

for Model Numbers beginning with:
DR-

Read this manual thoroughly before operating machine.
The model and serial numbers are on the data plate mounted on the machine.
Record the model and serial numbers below.
Refer to these numbers in any correspondence with AyrKing Corporation.

Model _____

Serial Number _____

Note: All procedures listed on these pages are general use guidelines.
Please refer to your company procedures for exact instructions.

IMPORTANT SAFETY INSTRUCTIONS

Read all instructions before operating. When using electrical appliances, basic safety precautions must be followed. Use this appliance only for its intended use as described in this manual. Verify that appliance is properly installed and electrically grounded by a qualified technician in accordance with local electrical codes. Do not attempt to repair or replace electrical components. A qualified technician should complete all servicing to these components. Before performing any service, disconnect the machine's power supply. Never wear loose-fitting or hanging garments while using any appliance. Ties, necklaces, etc. may catch on moving parts...possibly causing injury.

CAUTION - Risk of fire and/or electrical shock. Replace only with manufacturer's cord set:

DO NOT SPRAY MACHINE WITH WATER

Machine is designed to shed water & dust; however, **IT IS NOT WATER PROOF.**

OPERATION

(Numbers in parenthesis refer to parts view drawings)

ASSEMBLY:

- Begin each day with all components clean and thoroughly dry.
- Place drum drive base (1) on table top to the side of the plastic lug.



- Install rubber drive bands (8.4) between metal grooves on drum (8.5). Push plastic end cap (8.2) on end of drum, then flip over. When installing caps, take care to press evenly all the way around the cylinder, to insure a good seal.



- Install wire frame (8.1) inside drum (8.5), twist while pushing down



- Install second end cap (8.2) on opposite end using same procedure as above.



- Install silicone magnetic door (8.3) aligning within the opening in drum.



- Place fully assembled drum (8) on drive base (1) with the end with the notched wire frame facing the side the product will exit.



- Install loading chute frame (9) in grommets on loading end, slide loading chute (3) over frame making sure hook clips over end of loading frame



- Install exit ramp (20) in grommets on unloading side of drum. NOTE: dust guard on underneath side of ramp must be inside the drum. Place special rocker basket (24) with support arms on top of lug beside drum.



AUTOBREADING:

- Using aluminum scoop (23) load breadding into drum (8) by first removing the magnetic silicone door (8.3) to access inside of drum. Load breadding into drum until the level is just below the hole in the plastic end caps (8.2).
- Load raw product onto loading chute (3) allowing product to enter the drum (8).
- Product will pass through the breadding in the drum working its way to the opposite end which it will then make its way down the exit ramp (20) and into the basket (24) to then be rocked to remove any excess breadding
- Continually add breadding to drum as needed utilizing steps above.

DAILY CLEANING

(Numbers in parenthesis refer to parts view drawings)

- Always disconnect power supply when servicing or cleaning machine. **NEVER SPRAY MOTOR COMPARTMENT WITH WATER.**
- Remove loading ramp (3), loading ramp frame (9) and exit ramp (20). Take all items to wash sink.
- Disassemble drum (8) in reverse order of steps seen in the assembly section of "Operation". Take all items to wash sink.
- Coating basket (24) and aluminum scoop (23) can both be taken to wash sink to be cleaned.
- Clean motor drive base (1) with a towel soaked in detergent/water solution. Be sure to clean all crevices. Wipe off soapy solution using water rinsed towel until all surfaces are clean. Soak towel in sanitizing solution (or bleach/water solution) and wipe all surfaces thoroughly.
- In wash sink, spray all removed items with hose to dislodge any breadding. Soak all components in dish washing detergent and water solution.
- Place items upside down on tabletop to air-dry. Allow all components to thoroughly dry before re-using.

DR- PARTS VIEW

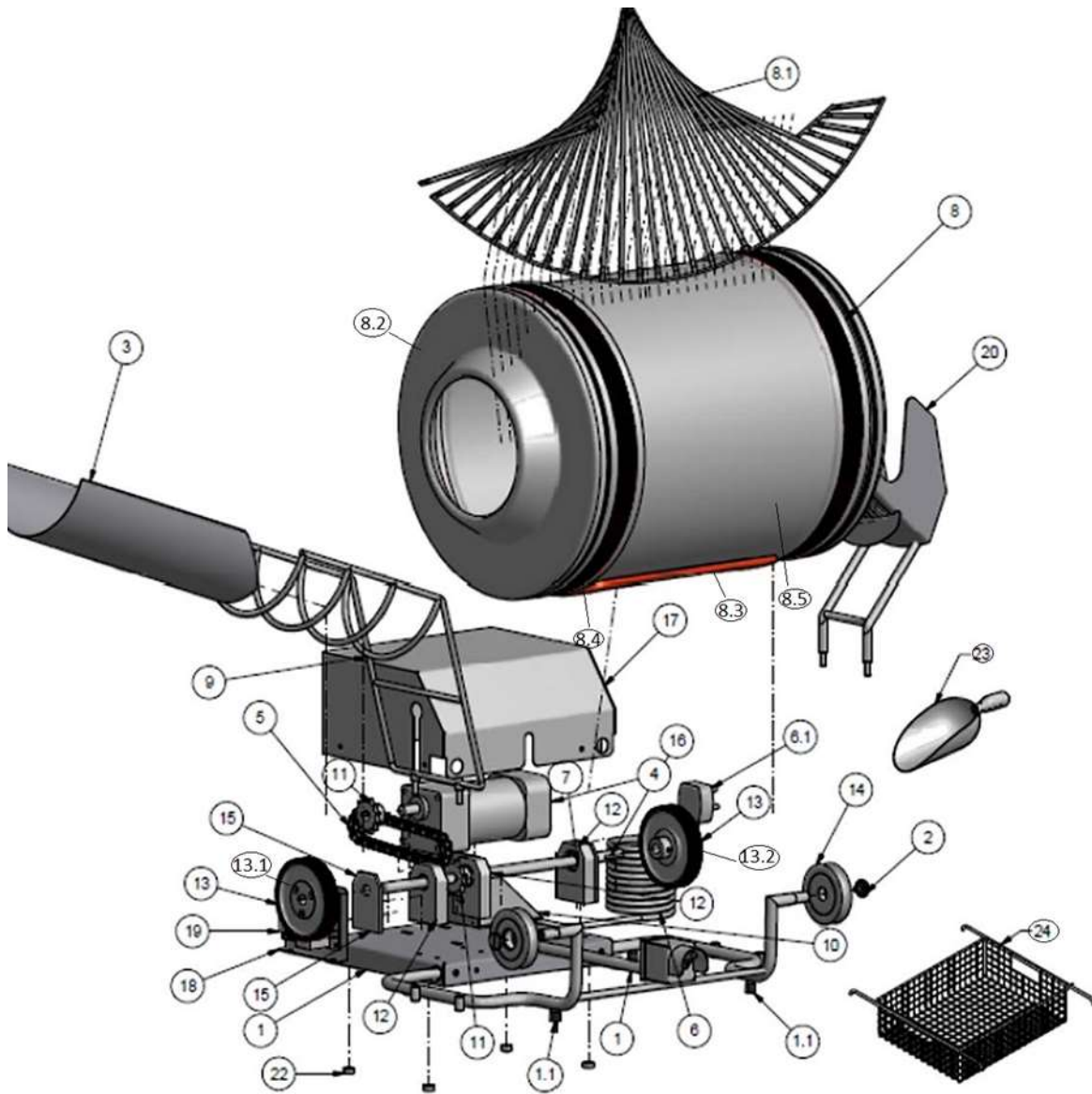

PARTS LIST

SOME ITEM/PART NUMBERS MIGHT NOT BE SHOWN IN PARTS VIEW DIAGRAM

Item #	Quantity	Part #	PART DESCRIPTION
1	1	DR317BT	Motor Base Assembly
1.1	4	3990432	Rubber Foot for base railing
2	2	DR309S	Bearing Wheel Screw
3	1	DR208	Loading Ramp
4	1	DR317	Dual Voltage Drive Motor
5	1	DR318	Drive Chain
6	1	B319	Coiled Power Cord
7	1	DR310	Wire Grommet
8	1	DR200	Stainless Steel Drum Assembly
8.1	1	DR202LF	DNA Rails S/S R->L Flow
8.1	1	DR202RF	DNA Rails S/S L->R Flow (PICTURED)
8.2	2	DR201	Plastic End Cap for Drum
8.3	1	DR205	Magnetic Silicone Door
8.4	2	DR204	Rubber Drive Band for Drum
8.5	1	DR203	Stainless Steel Drum
9	1	DR209	Loading Ramp Mounting Frame
10	1	DR317M	Motor Mounting Plate
11	1	DR319	Chain Drive Sprocket
12	3	DR320	Straight Bearing Support Base
13	2	DR302	Drive Wheel Assembly
13.1	2	DR305	Drive Wheel w/o Rubber Cover
13.2	2	DR304	Rubber Drive Wheel Cover
14	2	DR303	Double Bearing Wheel (Replaces DR309 Bearing Wheel)
15	2	DR308	Bearing Mount Seal
16	1	DR307	Straight Drive Shaft
17	1	DR317CT	Motor Compartment Cover
18	1	DR530M	Electrical Board Mount
19	1	DR530T	Electrical Board
20	1	DR207	Exit Ramp W/ Double Guardrail
20	1	DR206LF	Exit Ramp W/ Single Guardrail, Right to Left Flow (NOT PICTURED)
20	1	DR206RF	Exit Ramp W/ Single Guardrail, Left to Right Flow (NOT PICTURED)
22	4	5003410-005	Rubber Foot Under Motor Compartment
23	1	DR FLOUR SCOOP	Aluminum Scoop, 56 Oz
24	1	DR126	Coating Basket w/ Arms for B302
NOT PICTURED	2	DR321	Plug Vent Hole 1-5/8 inch

ALL ITEMS ARE NOT LISTED IN THIS MANUAL. CONTACT AYRKING FOR ASSISTANCE.

TERMS AND CONDITIONS

DAMAGED SHIPMENTS

Notify carrier in event of damaged shipments, whether apparent at time of delivery or concealed damage discovered after unpacking. File complaint with the carrier as the customer will be responsible for collection of damage claims. AyrKing retains no liability for damaged goods once the goods ship from our dock.

RETURNS

No returns will be accepted without written approval from AyrKing. All returned shipments must be freight prepaid and are subject to handling or re-stocking charges.

WARRANTY

AyrKing Corporation warrants that the AyrKing Breader/Blender/Sifter shall be free from original defects in workmanship and material provided the same has been properly stored, installed, serviced, maintained, and operated. AyrKing Corporation extends this warranty to the original purchaser only. This warranty specifically covers the mechanical and electrical components that constitute the drive system of the machine.

This warranty provides non-prorated replacement of defect components and labor coverage. This warranty begins on the date of initial use or 60 days from the date of shipment from our factory, whichever occurs first. The parts warranty is in effect for the period of 12 months. The labor warranty is in effect for the period of 90 days.

The end user is required to register ownership of this product with AyrKing Corporation by returning the warranty card supplied with the machine. This warranty shall be null and void if the product is not immediately registered with AyrKing Corporation.

Notify AyrKing Corporation of any performance failure. Specify model and serial number of the product when contacting AyrKing. AyrKing personnel will assist in evaluating the cause of failure, ship any necessary replacement components, and authorize a service agency call. Replacement components will be provided and shipped at no cost (via least expensive route) to the end user provided that the end user returns the defective component within two weeks (if required by AyrKing). AyrKing reserves the right to test and evaluate the failed component to determine whether the failure is covered by this warranty. If AyrKing does not receive defective components within two weeks of replacement component shipment (if required by AyrKing) or if the failure is determined not to be covered under this warranty, AyrKing will invoice the end user for the replacement component, shipping costs, and labor charges if applicable.

AyrKing Corporation is not responsible for any damages due to removal or any expenses incurred for installation of replacement component including but not limited to travel time, fuel charges, etc. AyrKing Corporation is not liable for any other expenses or costs due to the non-performance of the product including shipping costs on the mandatory return of defective product or component. The buyer assumes all risks and liability for results of use of product. This warranty does not apply to products that have been misused, subjected to negligence or accident, or altered/repared in any way so as to affect the product's performance or reliability. The brush assembly is excluded from warranty coverage. Nor does this warranty apply to any peripheral components such as lugs, plugs, pans, pots, baskets, or other items that may be bundled in a package with the Breader/Blender/Sifter.