



Thank you for your business!

We trust you will find this new
Breader/Blender/Sifter
to be quiet, efficient, and durable.

**Please return this completed page.
The owner is required to return this product
registration information immediately.**

The model and serial numbers are stamped on the nameplate
located next to the machine's controls.
Double sifter tables have two different serial
numbers - please list both. Please print clearly.

-----Second Fold Line-----

Place
stamp
here

AyrKing, LLC
2013 Cobalt Drive
Louisville, KY 40299-2417
USA

-----First Fold Line-----Seal with tape-----Do not staple-----

Store Name: _____ Store I.D.#: _____

Address: _____

City: _____ State/Province/Region: _____

Country: _____ Postal Code: _____

Telephone: _____ Fax: _____

Store Owner: _____

Model: _____ Serial Number(s): _____

This page intentionally left blank.



TELEPHONE: 1-502-266-6270 | USA Toll free: 1-866-266-6290 | www.ayrking.com

BREADER/BLENDER/SIFTER

Operation, Maintenance, and Warranty For Model Number BBSUL2934ADR



Read this manual thoroughly before operating machine.
The model and serial numbers are on the data plate mounted on the machine.
Record the model and serial numbers below.

Refer to these numbers in any correspondence with AyrKing, LLC.

Model _____

Serial Number(s) _____

Note: All procedures listed on these pages are general use guidelines.
Please refer to your company procedures for exact instructions.

IMPORTANT SAFETY INSTRUCTIONS

Read all instructions before operating. When using electrical appliances, basic safety precautions must be followed. Use this appliance only for its intended use as described in this manual. Verify that appliance is properly installed and electrically grounded by a qualified technician in accordance with local electrical codes. Do not attempt to repair or replace electrical components. A qualified technician should complete all servicing to these components. Before performing any service, disconnect the machine's power supply. Never wear loose-fitting or hanging garments while using any appliance. Ties, necklaces, etc. may catch on moving parts...possibly causing injury.

CAUTION - Risk of fire and/or electrical shock. Replace only with manufacturer's cord set. Specified plug type is required at time of purchase. Different power cords are available for other countries, additional charges may apply.

DO NOT SPRAY MACHINE WITH WATER

Machine is designed to shed water & dust; however, **IT IS NOT WATER PROOF.**



OPERATION

(Numbers in parenthesis refer to parts view drawings)

ASSEMBLY:

- Begin each day with all components clean and thoroughly dry.
- Place lug (8 or 2) in bottom rails, tight against backstop.
- Place dough ball pan (9) in rails underneath motor compartment.
- Position sifter screen (5) so that the end with pivot pin is located away from the motor compartment.
- Install brush (6), mating end with square hole onto square drive coupling (12) and press brush towards motor until opposite end of brush shaft clears pivot pin located on sifter screen (5). Center brush shaft hole on pivot pin then release brush. Rotate brush by hand to assure proper installation.
- Place brush cover/lug support (4), collar side up, over brush (6) so that brush cover hole is away from motor compartment.
- Place lug with hole (2) into sifter enclosure, aligning lug hole with brush cover (4) hole. Install lug plug (1) over hole in lug.

BLENDING:

- Place flour and spices in top lug (2). Press start button (18). While brush (6) is in motion, remove lug plug (1) and push breadings slowly through lug hole.
- Replace lug plug (1) over hole in top lug (2). After breadings has passed through sifter screen (5) and brush (6) has stopped rotating, remove bottom lug (8) and pour breadings into top lug (2). On models that have a bottom lug with hole (2) and lug plug (1), simply interchange the top and bottom lugs.
- Replace proper lug (8 or 2) tightly against backstop. Repeat steps for second blending of breadings.

SIFTING:

- Sifting is required after dough balls form during hand breadings of product. Press start button (18). While brush (6) is in motion, remove lug plug (1) and push breadings slowly through lug hole.
- Replace lug plug (1) over hole in top lug (2). After breadings has passed through sifter screen (5) and brush (6) has stopped rotating, remove bottom lug (8) and pour breadings into top lug (2). On models that have a bottom lug with hole (2) and lug plug (1), simply interchange the top and bottom lugs.
- Replace proper lug (8 or 2) tightly against backstop. Occasionally empty dough ball pan (9) into trash. Repeat above steps as often as needed.



DAILY CLEANING

(Numbers in parenthesis refer to parts view drawings)

- Always disconnect power supply when servicing or cleaning machine. **NEVER SPRAY MOTOR COMPARTMENT WITH WATER.**
- Remove top & bottom lugs (2 & 8), lug plug (1), brush cover (4), brush (6), sifter screen (5), and dough ball pan (9). Take all items to wash sink.
- Clean table and sifter enclosure with a towel soaked in detergent/water solution. Be sure to clean all crevices. Wipe off soapy solution using water rinsed towel until all surfaces are clean. Soak towel in sanitizing solution (or bleach/water solution) and wipe all surfaces thoroughly.
- In wash sink, spray all removed items with hose to dislodge any breading. Soak all components in dish washing detergent and water solution.
- Brush can be cleaned by using a round brush to remove soil.
- After cleaning brush (6), rinse in detergent solution and soak in sanitizing solution for five minutes.
- After soaking, remove the brush (6) and shake away excess moisture. Place brush on square post, [B219](#) (25) located on top of table or [B219H](#) located on wire shelves, by standing on end. Allow to fully air-dry before reinstalling brush (6).
- Clean the sifter screen (5) and brush cover (4) in the detergent/water solution with a towel or scrub pad if required. Rinse off detergent solution. Soak items in sanitizing solution for one minute.
- Rinse dough ball pan (9) and replace in sifter. Reinstall sifter screen (5). Place brush cover (4) on tabletop. Allow all components to thoroughly dry before re-using.
- Clean the lugs (2 & 8) and lug plug (1) in sink with towel or scrub pad if required. Rinse off detergent solution. Place items in sanitizing solution and soak for one minute. Place items upside down on tabletop to air-dry. Allow all components to thoroughly dry before re-using.

BBSUL2934ADR PARTS VIEW

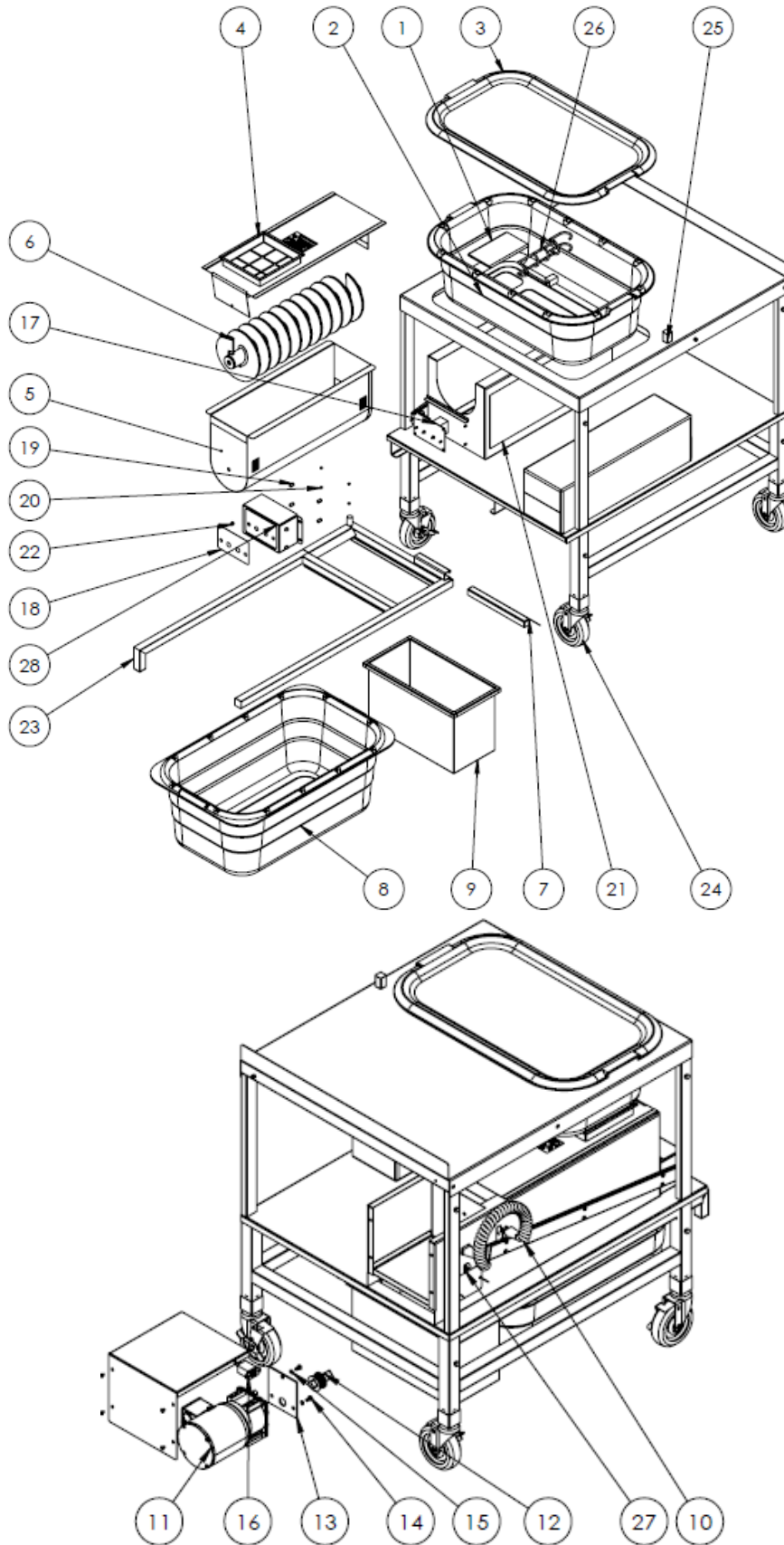



BBSUL2934ADR PARTS LIST

| ITEM | PART # | DESCRIPTION [NOMINAL SIZE] |
|------|------------|--|
| 1 | B101 | LUG PLUG, PLASTIC |
| 2 | B302 | LUG WITH HOLE, WHITE PLASTIC – [26”(660mm) X 16”(406mm)] |
| 3 | B325 | LUG COVER, WHITE PLASTIC – [26”(660mm) X 16”(406mm)] |
| 4 | B201SC1316 | BRUSH COVER, 20” W/ 1.1875” COLLAR |
| 5 | B202SX | SIFTER SCREEN, 20” W/ HOLES ON ONE SIDE AND BOTTOM |
| 6 | B160S | SIFTER BRUSH ASSEMBLY, WHITE BRISTLES, 20” (508mm) LONG |
| 7 | B203L | DOUGH BALL CHUTE |
| 8 | B303 | LUG WITHOUT HOLE, WHITE PLASTIC – [26”(660mm) X16”(406mm)] |
| 9 | B504 | STAINLESS DOUGH BALL PAN – [7.625”(195mm) X 14.75”(376mm)] |
| 10 | B319 | COILED POWER CORD, NEMA 5-15 PLUG 120V USA & CANADA [24” 610mm)] |
| 11 | B117 | PARALLEL SHAFT GEAR MOTOR - 115/230 VOLT, 50/60 Hz |
| 12 | B206 | DRIVE COUPLING ASSEMBLY FOR BBS-U |
| 13 | B207 | MOTOR COMPARTMENT SEAL |
| 14 | B403 | BOLT - MOTOR ASSEMBLY |
| 15 | B404 | LOCK WASHER – MOTOR ASSEMBLY |
| 16 | B145 | RECEPTACLE–UNIVERSAL 120/240V THREE-PRONG MALE WITH NOISE FILTER |
| 17 | B530 | CIRCUIT BOARD TIMER RELAY - 120/240 VOLT, 50/60 Hz |
| 18 | B531 | CONTROL PANEL OVERLAY |
| 19 | B532 | NYLON WASHER/SPACER SET FOR B530 |
| 20 | B533 | NUT FOR B530 TIMER BOARD |
| 21 | B121 | INSTRUCTION LABEL (B120 FOR BBS-M-3314, MANUAL SIFTER) |
| 22 | B402 | ACORN NUT - TIMER CONTROL BOX |
| 23 | B699H | LUG RAIL WITH OPEN FRONT AND HANDLE |
| 24 | B240 | 5” (127mm) CASTER, LOCKING |
| 25 | B219 | BRUSH POST (LOCATED ON TOP OF TABLE) |
| 26 | B219H | WIRE SHELF BRUSH POST HANGER |
| 27 | B146 | P-SHAPED PLASTIC CLIP TO AFFIX POWER CORD TO SIFTER |
| 28 | B315A | CONTROL BOX FOR MODELS BEGINNING W/ BBSUL2934A--- |



BBS OPTIONAL PARTS & ACCESSORIES

| PART # | DESCRIPTION [NOMINAL SIZE] |
|-----------|--|
| B126 | RECTANGULAR, STAINLESS STEEL WIRE FEATHERING BASKET |
| DRUF120TP | DRUMROLL AUTOMATED BREADER KIT |
| B652 | SLIDE OUT SHELF FOR ICE BATH |
| B550 | 12" SOLID SIDE SHELF FOR BBSUL2934A---- MODELS |
| B550H | 12" SIDE SHELF FOR BBSUL2934A---- MODELS WITH HOLE FOR DIP POT |
| B551 | 19" SIDE SHELF FOR BBSUL2934A--- MODELS, WITH TWO HOLES FOR DIP POTS |
| IB20 | 20" ICE BATH FOR USE WITH B652 |
| IB28 | 28" ICE BATH FOR USE WITH B652 |
| B122B | ROUND DIP BASKET WITH DRAWN WIRE |
| B122H | STAINLESS ROUND DIP BASKET W/ CIRCULAR OPENINGS |
| B122W | S/S ROUND DIP BASKET W/ WHITE HANDLE |
| B294 | STAINLESS STEEL TALL OVERSHELF FOR BBSUL2934 |
| B124 | STAINLESS STEEL ROUND DIP POT LID |
| B150S | SIFTER BRUSH ASSEMBLY, BLACK BRISTLES, 20" (508mm) LONG |
| B101S | LUG PLUG, SILICONE |
| B302G | LUG WITH HOLE, GRAY PLASTIC – [26"(660mm) X 16"(406mm)] |
| B302R | LUG WITH HOLE, RED PLASTIC – [26"(660mm) X 16"(406mm)] |
| B325G | LUG COVER, GRAY PLASTIC – [26"(660mm) X 16"(406mm)] |
| B325R | LUG COVER, RED PLASTIC – [26"(660mm) X 16"(406mm)] |
| B303G | LUG WITHOUT HOLE, GRAY PLASTIC – [26"(660mm) X 16"(406mm)] |
| B303R | LUG WITHOUT HOLE, RED PLASTIC – [26"(660mm) X 16"(406mm)] |
| B231 | 28" STAINLESS STEEL BACKPANEL FOR BBSUL2934A |
| B262 | LEFT BBSUL2934 BACKPANEL POST |
| B263 | RIGHT BBSUL2934 BACKPANEL POST |
| B290 | OVERSHELF FOR BBSUL2934A |



PROBLEM SOLVING GUIDE

Many problems have a simple solution. Please use this guide to help resolve operational difficulties. Visit www.ayrking.com/maintenance/ for DIY Guides.

Contact AyrKing, LLC if unable to correct any problem.

PROBLEM

POSSIBLE SOLUTIONS

Flour on floor.

Push bottom lug tight against backstop. Check dough ball pan level, empty if full.

*Dough balls in sifted
breading.*

Ensure the doughball pan is in the correct position. Check proper position of brush cover. Check dough ball pan level, empty if full. Check that pivot pin end of screen is positioned tight against sifter enclosure. Inspect screen for damage, replace if necessary.

*Excessive flour in dough ball
pan.*

When brush is new (first few days of operation) this is normal until brush develops a set. For first few days push flour into brush area slower. Verify that holes in brush cover and in top lug are at opposite end of screen from motor compartment. Brush may be worn out, replace with new brush.

Brush and/or screen clogged with flour. Brush not in proper contact with screen.

Make certain that the brush and sifter screen are thoroughly dry before use. Check brush for flattened bristles. If evident, wash brush in hot water and air-dry on brush post in vertical position. (Never lay brush in flat position to dry). This is recommended only as a procedure to straighten flattened bristles. Usually bristles should not be subjected to hot water. If this fails to cure the problem, replace brush. (Note: daily cleaning and thorough, proper drying extend brush life). Brush may be worn out, replace with new brush.

Dough balls in sifter screen. Motor will not operate.

Check dough ball pan, empty if full. Check dough ball chute for obstructions. Check power source (plug, circuit breaker, frayed wires, etc.). Verify proper mechanical motion of start push button. Have qualified technician check operation of components.

ELECTRICAL SCHEMATICS

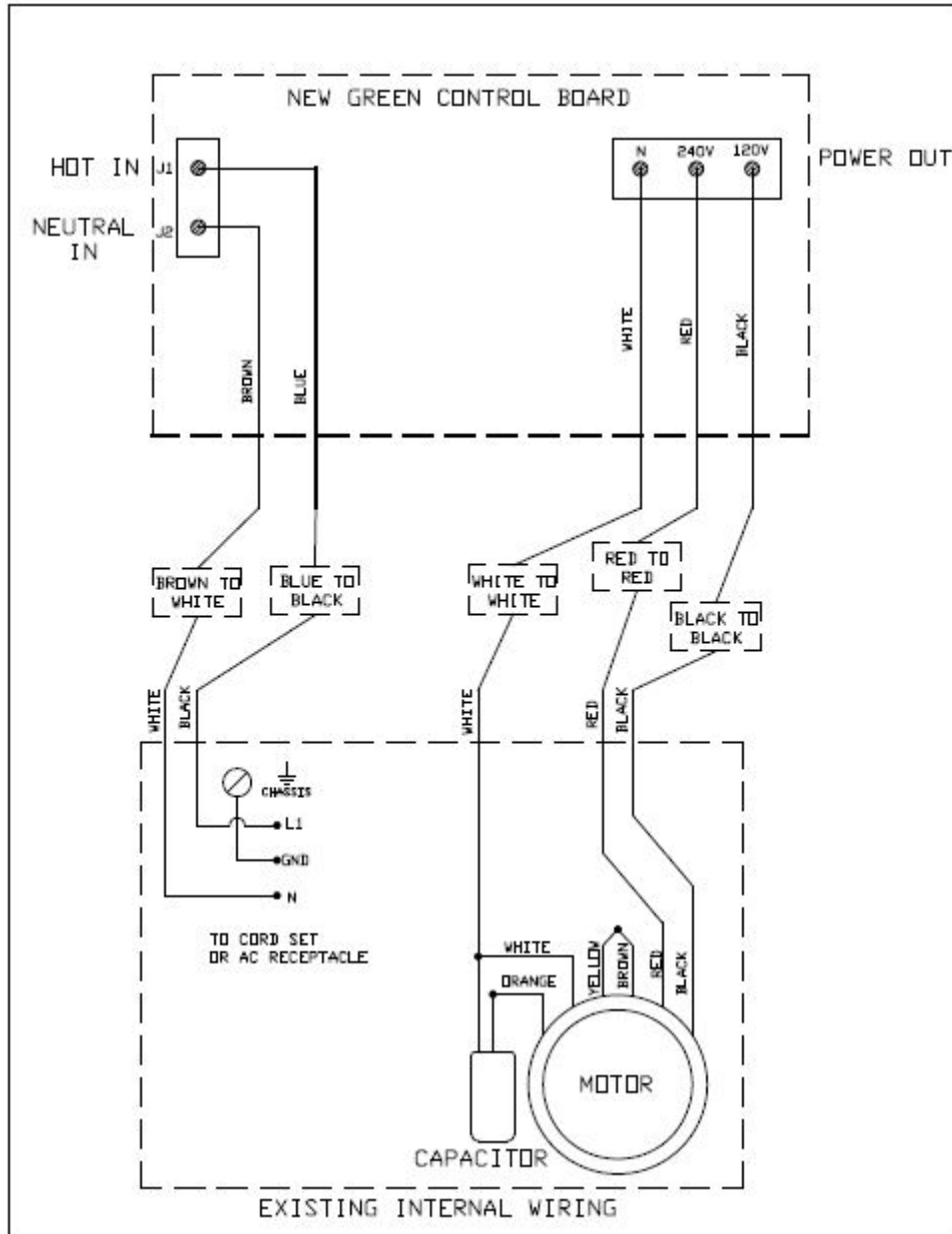



TERMS AND CONDITIONS

Description

This warranty is in effect for AyrKing equipment used within North America. See the International Claims section for warranty claims outside of North America. AyrKing warrants that the AyrKing equipment shall be free from original defects in workmanship and material, provided the equipment has been properly stored, installed, serviced, maintained, and operated. AyrKing extends this warranty to the original purchaser only. This warranty specifically covers the mechanical and electrical components for our equipment.

Registration

The end user must register ownership of their equipment with AyrKing by returning the warranty card supplied with the machine or registering their equipment on the AyrKing website at <https://www.ayrking.com>.

Coverage and Reimbursement

- AyrKing will reimburse up to 1.5 Hours of labor charges. Contact AyrKing tech support for approval if any repair will take over 1.5 hours to complete. CONTACT: 1-502-266-6270 *Tech Support*
- AyrKing reserves the right to deny all labor (time) charges considered excessive for any repair.
- AyrKing will not reimburse the cost of warranty parts bought from other vendors or parts suppliers.
- AyrKing will reimburse up to 50 miles travel time, unless approved by AyrKing tech support.
- Warranty coverage includes standard ground shipping of replacement parts. Special handling of Shipment (i.e. Next Day Air, Saturday Delivery, 2nd Day Air, etc.) costs are NOT included.

This warranty provides non-prorated replacement of defective components and labor coverage. This warranty begins on the date of installation or 60 days (about 2 months) from the date of shipment from AyrKing's warehouses, whichever occurs first unless proof of installation can be provided. **The parts warranty is in effect for 12 months. The labor warranty is in effect for 90 days (about 3 months).**

The manufacturer's obligation under this warranty shall be the replacement or repair of defective parts within the warranty period. Excessive labor (more than 1.5 hours) required to access AyrKing equipment built into cabinets, tables, or structures by others, is NOT covered under this labor warranty. Only labor performed during regular working hours qualifies under this warranty. AyrKing will not reimburse overtime premiums. AyrKing LLC is not responsible for any damage due to removal, or any expenses incurred for installation of replacement component including but not limited to excess travel time, fuel charges, etc.

If, upon inspection, it is determined that this AyrKing equipment has not been properly installed, used appropriately, modified, or maintained, the warranty will be void. If the equipment has been subjected to misuse or misapplication, neglect, abuse, accident, damage during transit or delivery, fire, flood, riot or acts of God, then this warranty shall also be void. When any situation occurs which voids the warranty then AyrKing shall not be liable for any damage to any person or any property which may result from the use of the equipment thereafter. The warranty is limited to AyrKing manufactured equipment only and does not apply to other equipment which may be connected to or installed within.

Claims

Notify AyrKing of any performance failure (1-502-266-6270). Specify model and serial number of the equipment when contacting AyrKing. AyrKing personnel will help in evaluating the cause of failure, ship any necessary replacement components, and authorize a service agency call if applicable. Replacement components will be supplied and shipped at no cost (via least expensive route) to the end user if they return the defective part within two weeks (if required by AyrKing). AyrKing reserves the right to test and evaluate the failed part to determine whether the failure is covered by this warranty. If AyrKing does not receive defective components within two weeks of replacement part shipment (if required by AyrKing) or if the failure is determined not to be covered under this warranty, AyrKing will invoice the end user for the replacement part, shipping costs, and labor charges if applicable



TERMS AND CONDITIONS (Cont.)

International Claims

Please contact your kitchen equipment supplier to process warranty claims. AyrKing will reimburse the supplier for warranty repairs. The parts warranty is in effect for 12 months. The labor warranty is in effect for 90 days.

*The International warranty will be extended for up to 60 days after shipping from an AyrKing warehouse or with proof of the installation date.

Missing or damaged Items:

Claims of items missing from a shipment or damaged in transit must be reported within five (5) business days of receipt of the merchandise. Anytime you receive items, please take some time to carefully inspect the equipment. Each shipment will include a packing label on the box. Please verify the receipt of all items listed on the packing label.

Order Cancellation

- **Unshipped Order:** If the order is still open in AyrKing's system, please contact AyrKing's customer relations team at order@ayrking.com to cancel the order. The customer may not be charged any shipping or restocking fees if the order has not been prepared or shipped.
- **Shipped Order:** If the customer order has already shipped, the customer may refuse the shipment when it arrives, or the customer can accept the order and start a return authorization through AyrKing's returns process. When a shipment is refused, it will come back to AyrKing's warehouse, and the customer will be charged a restocking fee and any shipping fees associated with the return.
- **Received Order:** If the customer has already received their purchased item(s), the customer must contact AyrKing's customer relations team at order@ayrking.com to start a return. The customer will be provided with a return authorization number and instructions on how to ship their items back.

Standard Returns and Restocking Fees

New and Unused, regularly stocked (non-customized) items may be returned by contacting AyrKing's customer relations team within 90 days (about 3 months) of the invoice date. A representative will create a return authorization and provide further instructions for completing the return process. Each return is subject to a 20 percent restocking fee which will be deducted from the refund amount. The customer will also be responsible for securing a shipping agent to return the merchandise, plus all shipping fees incurred. All returns must be finalized within 30 days of approval. If the merchandise is not returned within this timeframe, the return authorization will be canceled, and the return will be voided.

Restocking Fees

There are many costs involved in processing a return. AyrKing charges a 20 percent restocking fee for all items returned.