

AyrKing Corporation

Breader/Blender/Sifter



AyrKing offers a back to back manual breading workstation with integrated automatic Blender/Sifter machines. Rotary brush sifter operates without detrimental vibration or agitation. Spirally configured nylon bristles form an auger to eject unwanted dough balls to a waste container. Ingredients are fully blended as brush tumbles breading media before it exits through sifter screen. Unique process prevents dough ball grinding, eliminates usual sifting noise, & blends ingredients as it ejects waste.

Photo of BBS-U-4561



INCLUDED ACCESSORIES

- (2) B101 Red plastic lug plug
- (2) B304 White plastic dough ball pan
- (2) B122 Round dip basket, stainless steel wire
- (2) B123 Round dip pot, stainless steel
- B302 White plastic breading lug with hole
- B303 White plastic breading lug without hole
- B325 White plastic lug cover
- B302G Gray plastic breading lug with hole
- B303G Gray plastic breading lug without hole
- B325G Gray plastic lug cover

OPTIONAL ACCESSORIES

- B241 Swivel casters, four locking 5"
- B215 Divider panel, 18"H with basket hooks
- B216 Divider panel, 18"H w/ hooks & overpan
- B126 Feathering basket, stainless steel wire
- B124 Round dip pot lid, stainless steel

ADVANTAGES

- Sift and blend 30 lbs (14 kg) of breading in 60 seconds in each sifter!
- Rotary auger brush blends, sifts, and ejects dough balls simultaneously
- Blending brush action prevents ingredient segregation, unlike vibrating or agitating systems
- Quiet, vibration-free operation creates results, not disturbances
- Sixty second timed cycle frees labor and saves energy
- Raised s/s lip around sifter opening prevents tabletop spills from contaminating sifted breading
- Fully enclosed sifter with only four internal parts, reduces dust and allows quick and easy cleaning
- Direct drive, steel geared motor & solid stainless steel fabrication provide lasting performance
- Gray and white colored breading lugs help distinguish breadings
- Optional divider panels available (B216 shown in drawing on back)

MODEL

BBS-U-4561 45"L by 61"W back to back table with two sifters

AyrKing Corporation
2013 Cobalt Drive
Louisville, KY 40299-2417

Telephone 502-266-6270
Facsimile 502-266-6274
www.ayrking.com

AyrKing Corporation

Breader/Blender/Sifter

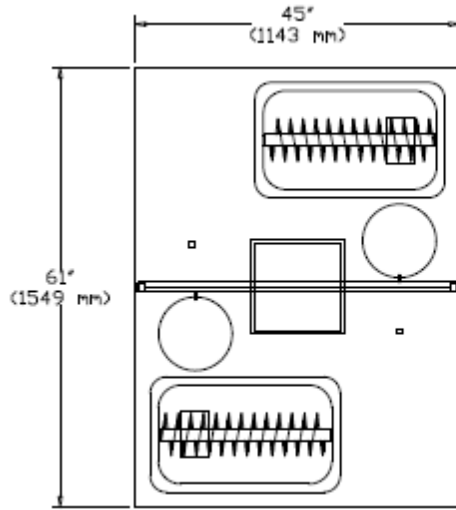

TOP VIEW

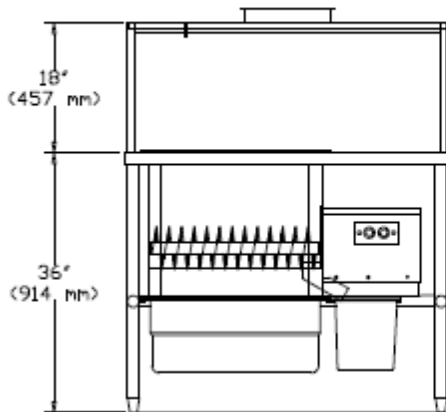

FRONT VIEW

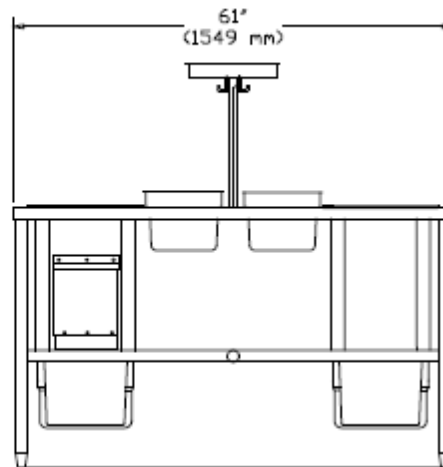

RIGHT END VIEW

CRATED MEASUREMENTS

MODEL
BBS-U-4561

<u>LENGTH</u>	<u>WIDTH</u>	<u>HEIGHT</u>	<u>WEIGHT</u>
48" (1219mm)	65" (1651mm)	44" (1118mm)	396 lb (180kg)

UNCRATED
311 lb (141kg)

ELECTRICAL

Timed control board automatically senses voltage & operates at either:

115V, 50/60Hz, 1 phase, 1.6 AMP, 184W per sifter

230V, 50/60Hz, 1 phase, 0.9 AMP, 207W per sifter

Each sifter includes universal male three prong, recessed AC receptacle

(IEC 320 C13) mating to an 8 foot (2438mm) cord with NEMA 5-15P male three prong plug

WARRANTY

One Year Parts

Ninety Days Labor

No Travel Time

Specifications subject to change without notice. Version 03/17

AyrKing Corporation
2013 Cobalt Drive
Louisville, KY 40299-2417

Telephone 502-266-6270
Facsimile 502-266-6274
www.ayrking.com