

## FPOF-50/ FPOF-80

### Explosive view of product and parts

⚠ The use of parts provided by other companies, our company has the right not to provide warranty service;

⚠ Order replacement parts from authorized representatives and after-sale service agency.

⚠ Provide the model number, serial number and description when you order components.

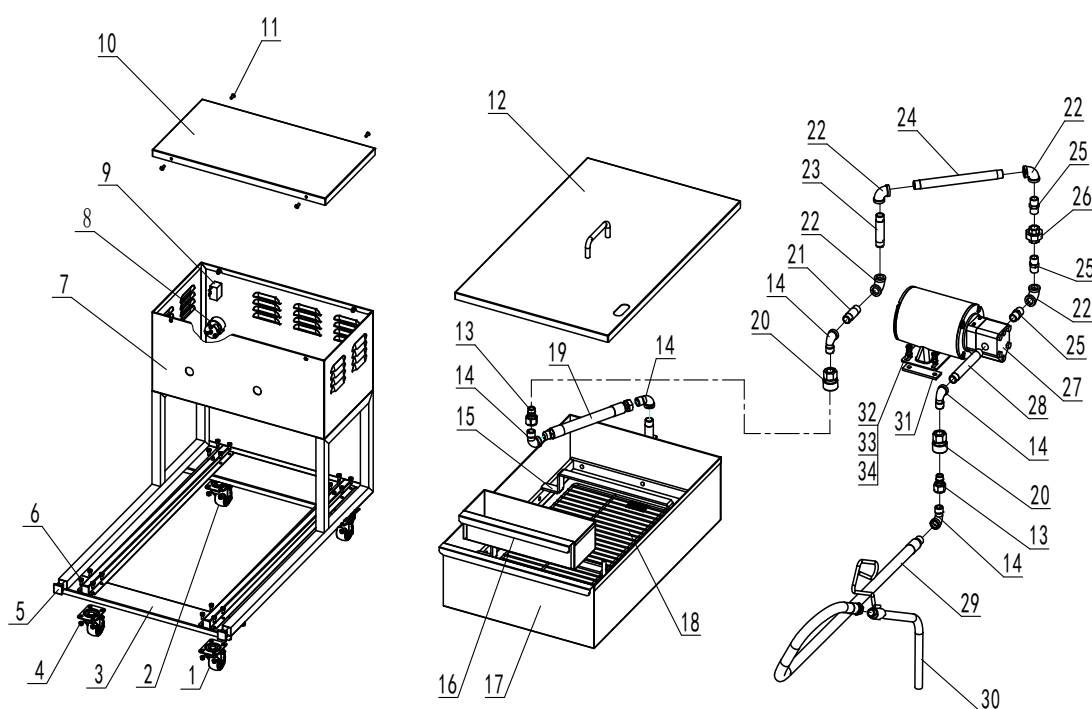

No.	Matters Code	Component name	Qty	Dimensions (mm)/Model	Notes
1	<a href="#">B0604401</a>	Wheels without brake	2	2"	
2	<a href="#">B0604402</a>	Wheels with brake	2	2"	
3	22217002001	Chassis unit	1	511*275*800	FPOF-80
	22217001001			411*275*700	FPOF-50
4	<a href="#">301080002</a>	Galvanized flange face nut	16	M6	
5	301160120	Stopper	2	25*25	
6	301081042	Galvanized flange face screw	16	M6*12	
7	22217002004	Electrical box unit	1	511*275*233	FPOF-80
	22217001004			411*275*233	FPOF-50
8	305190001	Flanged Inlet	1	125V 5-15P	
9	305060037	Switch	1		

10	22117002019	Electrical box cover plate	1	514*280*20	FPOF-80
	22117001019			414*280*20	FPOF-50
11	301081021	Cross screw	10	M5*12	
12	22217002003	Filter pan cover	1	455*746*70	FPOF-80
	22217001003			355*646*70	FPOF-50
13	301050343-1	Quick disconnect, male	2	1/2"	
14	301050376	Internal and external elbow	5	1/2"	
15	22217002006	Filter paper retainer rack	1	430*700*85	FPOF-80
	22217001006			330*600*85	FPOF-50
16	22217002008	Filter catch basket	1	330*147*83.5	FPOF-80
	222170021008			230*147*83.5	FPOF-50
17	22217002002	Filter pan	1	447*777*234.5	FPOF-80
	22217002002			347*677*234.5	FPOF-50
18	301100090	Filter paper support rack	1	665*395	FPOF-80
	301100091			565*295	FPOF-50
19	301050340	Filter pan inlet hose	1		
20	301050343-2	Quick disconnect, female	2	1/2"	
21	301060341	Pump connecting pipe 3 L=60mm	1		
22	309020044	elbow	4	1/2"	
23	301060340	Pump connecting pipe 2 L=90mm	1		
24	301060339	Pump connecting pipe 1 L=238mm	1		
25	301050346	Two pipes joint	3	1/2"	
26	301050344	loose joint	1	1/2"	
27	305140006	Pump	1		
28	301060342	Pump connecting pipe 4 L=150mm	1		
29	301050341	Flush hose w/threaded end fitting	1		
30	22217002007	Nozzle w/handle bracket only	1		
31	22117002031	Crash pad	2		
32	301081054	hexagonal screw	4	M8*25	
33	301082021	Spring washer	4	M8	
34	301082022	Flat gasket	4	M8	

### Accessories List

code	name	quantity
22217002005	Cleaning scoop	1 piece
305040045	cable	1 piece
301060321	Oil drain pipe	1 piece
304080732	Instructions	1 piece

Our products have the advantages of good durability and low maintenance charge. But to update some components and necessary maintenance, can prolong life length of the products. Contact the dealer for assistance. To avoid confusion, please follow the format of “Explosive view of product and parts” in this manual.