

# **Gas Heavy Duty Stock Pot Stove Operating Instructions**

Before you begin, please read these instructions carefully to use this product correctly, to make the product perform ideally, and to avoid hazards.

**Models: ATSP-18-1/ ATSP-18-2**

**ATSP-18-1L/ ATSP-18-2L**

Dear customers and users :

Thank you for purchasing our products. In order to be able to better use this product, please read these instructions carefully before any operation, and follow the guide, to avoid any unnecessary trouble during using.

Please keep this instruction manual in a safe place for convenient reference and operation.

This instruction manual is subject to any change without further notice, and the manufacturer reserves the right of final interpretation.

The appliance is designed for commercial purposes, not for household use.

A statement instructing the purchaser to post in a prominent location instructions to be followed in the event the user smells gas. This information shall be obtained by consulting the local gas supplier.

**FOR YOUR SAFETY**

Do not store or use gasoline or other flammable vapors or liquids in the vicinity of this or any other appliance.

**WARNING:** Improper installation, adjustment, alteration, service or maintenance can cause property damage, injury or death. Read the installation, operating and maintenance instructions thoroughly before installing or servicing this equipment.

**Gas Heavy Duty Stock Pot Stove**  
**The Installation, Operation and Maintenance Guide**

**Contents**

1. Safety Protection .....	3
2. Brief Introduction.....	3
3. Manufacturer's Authority and Responsibility .....	3
4. Parameter Specifications.....	4
5. Transport and Storage .....	6
6. Installation and Debugging.....	6
7. Safety Notices and Precautions.....	8
8. Operating Instructions.....	9
9. Cleaning and Maintenance.....	11
10. Troubleshooting .....	12
11. Spare Parts.....	14
12. Accessories List.....	18

## 1. Safety Protection

- ⚠ Please make sure that the operator is an authorized and licensed technician before you allow him/her to install and operate the products. Be sure to strictly follow this instruction guide during installation and using. The manufacturer is not responsible for any dangers or accidents caused by improper operation or maintenance.
- ⚠ Do not store flammable or explosive objects around the product. Keep all flammable and explosive objects at a safe distance away from the product for normal use.
- ⚠ Place the product in a reasonable position. Regarding related matters of gas, customer should execute the requirements of local gas supply sector;
- ⚠ If you smell a gas leak, turn off the gas valves immediately and call the gas company;
- ⚠ The product should not be operated by those under 18 years of age, or those with physical or mental disorders, or disabilities that lack the necessary knowledge or experience unless with appropriate instructions and sufficient safety.

## 2. Brief Instruction

The product is a series of gas char broilers in our company production, which is novel designed, reasonable structured, convenient operated, durable used, and convenient maintained. It's equipped with a cast-iron burner and a high efficiency stainless steel tubular burner and a pilot light, and convenient to ignite the main fire burner. This is hotel, supermarket, western restaurant, noshery and food industry's ideal cooking product equipment.

## 3. Manufacture's Authority and Responsibility

Banning of all or partial transformation to the products without the manufacturer's explicit authorization.

Manufacturers refused to undertake responsibility to third parties as the following reasons:

- ⚠ Not follow this instruction guidance and warning in in using and testing;
- ⚠ Not in accordance with the requirements of technical parameters using this product;
- ⚠ Incorrectly or irrationally using the product by untrained personnel;
- ⚠ Not obey the local law using this product;
- ⚠ Be repaired or changed by unauthorized technicians;
- ⚠ Use the spare parts or accessories provided by non-manufacturers;
- ⚠ Accidents caused by force majeure;
- ⚠ Not strictly comply with related guide of this instruction by any reason.

## 4. Parameter Specifications

### 4.1. Outline Dimensions(in)\*

ATSP-18-1

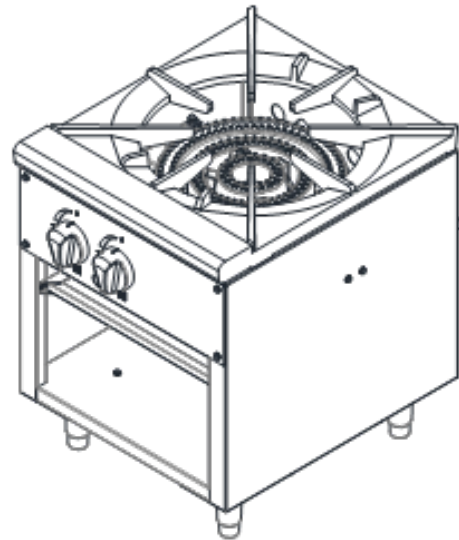
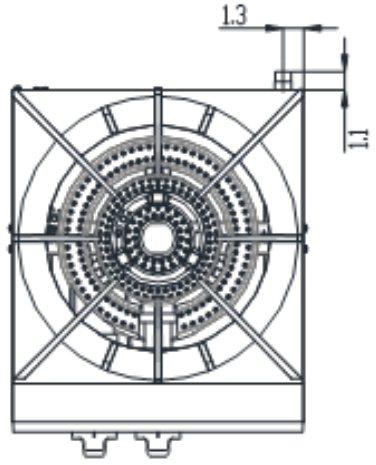
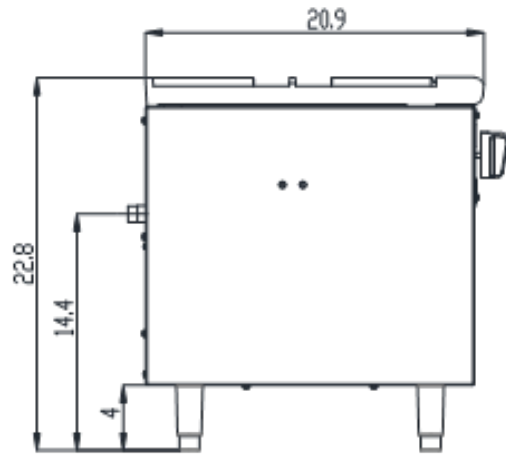
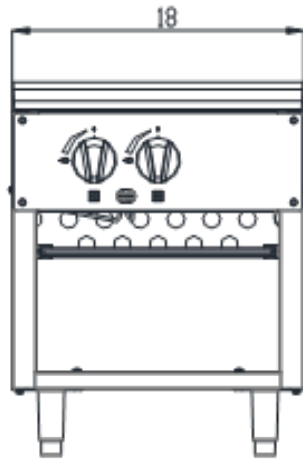

ATSP-18-2

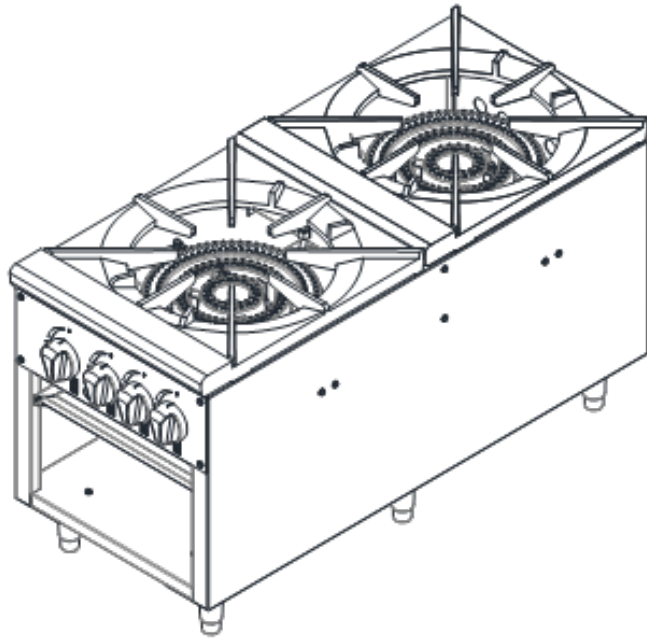
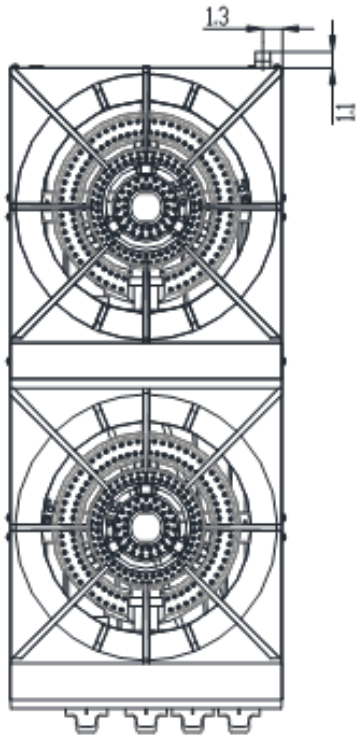
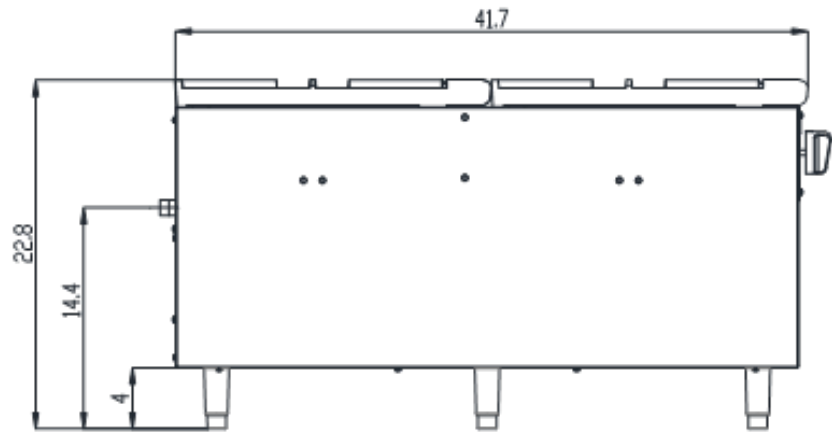
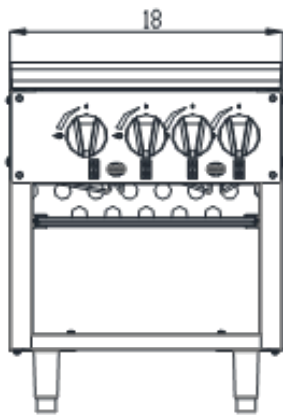

ATSP-18-1L

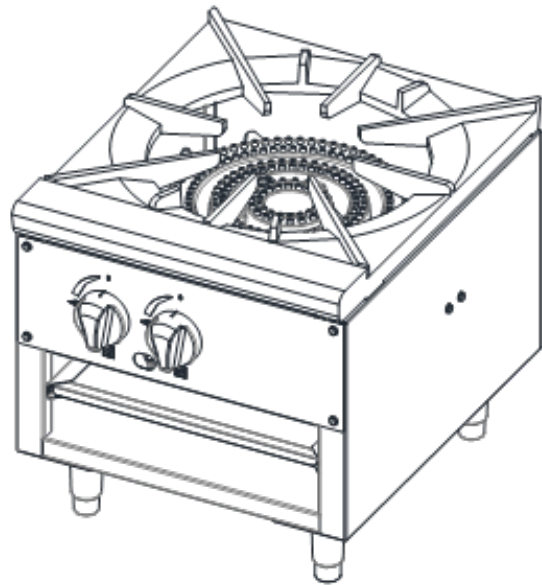
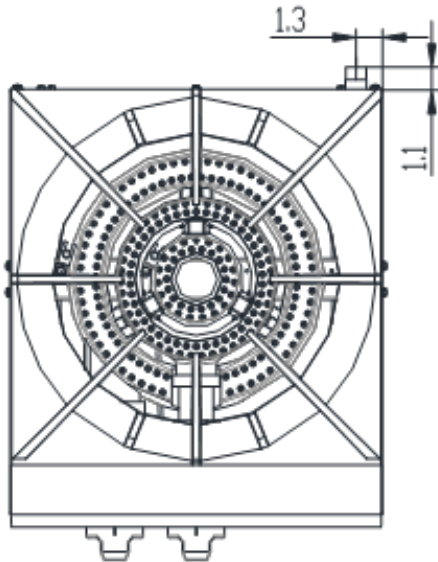
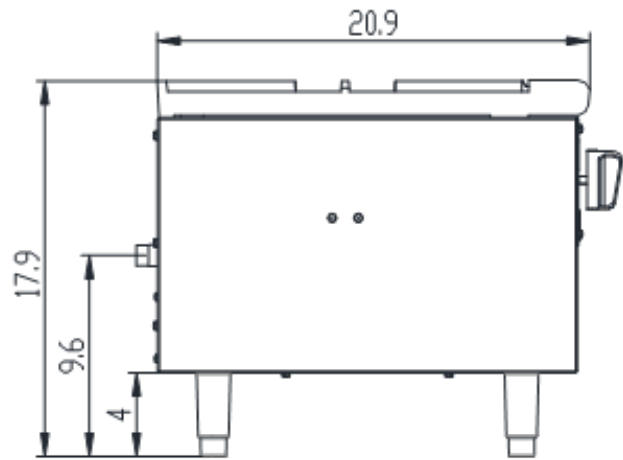
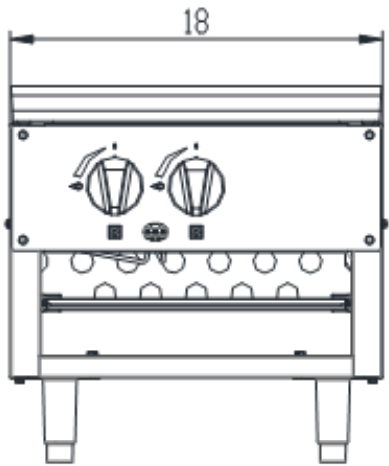

ATSP-18-2L

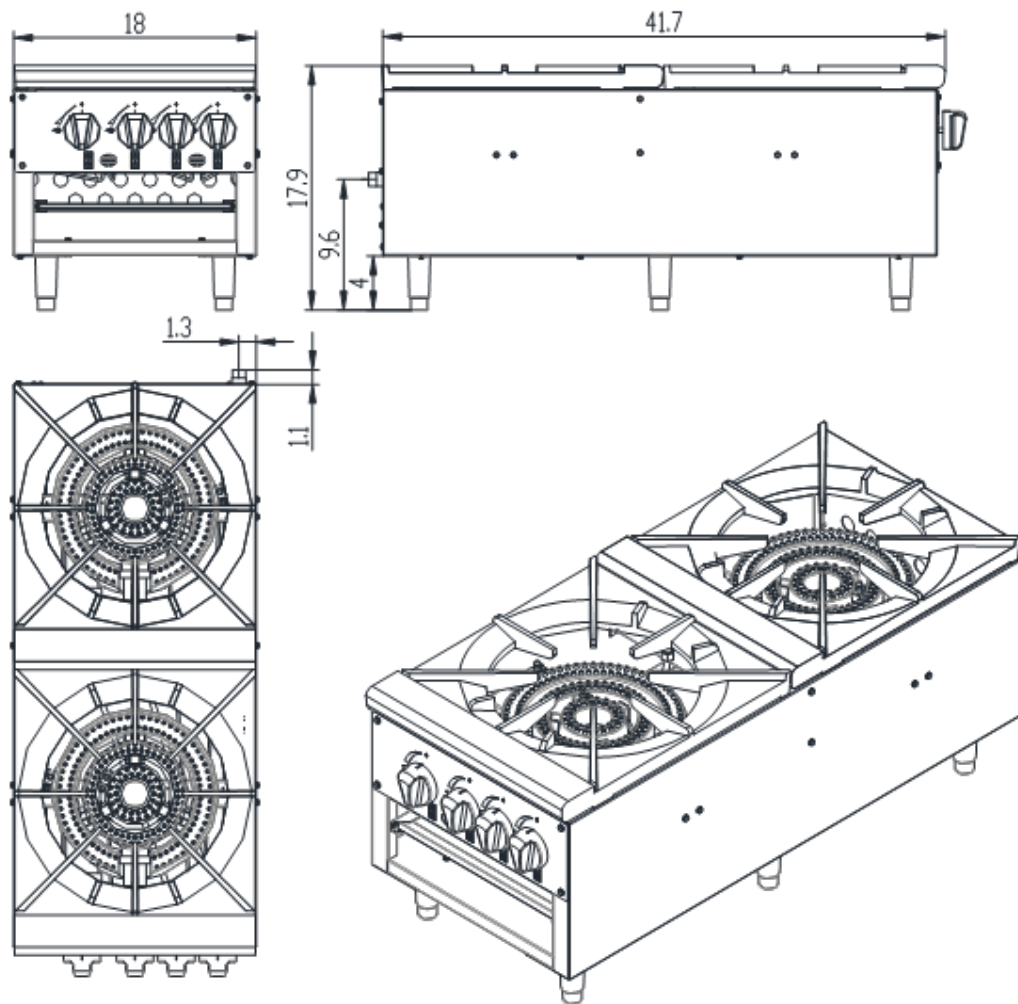

#### 4.2. Information of Gas Supply and Burner

The minimum supplied gas pressure regulator is factory set at 4"Natural Gas W.C, and 10"L.P. Gas W.C. The external thread of product's intake-tube is 3/4 inches.

<Table 1>

Model	#of burners and control method	Gas Species	Intake-tube pressure ( in.W.C. )	Per BTU B.T.U./h	Total BTU B.T.U./h	Nozzle No.
ATSP-18-1	1 set Independent control	Natural Gas	4	80,000	80,000	#32
		L.P. Gas	10	80,000	80,000	#49
ATSP-18-2	2 sets Independent control	Natural Gas	4	80,000	160,000	#32
		L.P. Gas	10	80,000	160,000	#49
ATSP-18-1L	1 set Independent control	Natural Gas	4	80,000	80,000	#32
		L.P. Gas	10	80,000	80,000	#49
ATSP-18-2L	2 sets Independent control	Natural Gas	4	80,000	160,000	#32
		L.P. Gas	10	80,000	160,000	#49

#### 5. Transport and Storage

In the process of transportation, handle carefully and keep upright to prevent damage of the product packing. Wrapped equipment should not be in open air for a long time, and shall be placed in a well-ventilated and non-corrosive gases

warehouse. When equipment needs temporary storage, rainproof measures should be taken.

## 6. Installation and Debugging

- ⚠ Any erroneous installation, adjustment, refit, overhaul or maintenance may cause property damage or personal injury. The work shall be performed by authorized and licensed technicians, otherwise the manufacturer has the right not to provide warranty service;
- ⚠ Only be installed in accordance with the local code. If no similar standard, you should conform to the National Fuel Gas Code, ANSI Z223.1/NFPA 54, the National Gas Installation Code, CSA-B149.1, or the L.P. Gas Installation Code, CSA-B149.2 as applicable;
- ⚠ The appliance individual shutoff valve must be disconnected from the gas supply piping system during any pressure testing of that system at test pressures in excess of 1/2psi (3.45kPa).

### 6.1. Unpacking and Installation

- ⚠ Please dispose of all packaging materials and residues after unpacking;
  - ⚠ Check the equipment. If it is damaged, please keep wrappers and receipts which must be signed by the carrier representative (Driver), and contact the carriers to pursue a claim within 15 days after receiving;
  - ⚠ Check all accessories complete. Refer to P16 table 4;
  - ⚠ Be sure to install supporting legs before using, and do not tear up any label or logo before normal using;
  - ⚠ Please read these instructions carefully before installation and operation. Please contact your local agent if you have any questions;
  - ⚠ The equipment shall be installed on a level, solid, non-skid and incombustible surface, and placed in a well-lighted work area with waterproof, and away from children and customers;
  - ⚠ The installation position is a well-ventilated place in accordance with the local regulations;
- The charbroiled must be installed under the matched cooking fume exhauster according to the local regulations;
- ⚠ **Important: Installation and ventilation laws, and codes are very different, you should state and comply with all codes of the National Fire Protection Association Inc when it comes to requirements for installation of equipment;**

- △ Screw 4 adjustable stainless steel legs in the tapping hole with four corners of the charbroiled bottom, ensure sufficient space for ventilation;
- △ Adjustable stainless steel legs to make the equipment level, and get the same level with other series of the same stove; Please lift the equipment rather than drag if you need to move it;
- △ Supplied gas pressure regulator is factory set at 4"Natural Gas W.C, and 10"L.P. Gas W.C;
- △ The equipment can only be placed on the incombustible counter top, and keep a distance of at least 6 inches(152mm) to equipment's both sides and back, and keep a distance of at least 4 inches(102mm) to the bottom;
- △ Do not put anything around the equipment, and on the counter top and bottom, in order to avoid influencing combustion and air circulation;
- △ Leave enough distance in front of the equipment to take apart the control panel. All major parts, in addition to the burner remove from the front intake-tube;
- △ It may be necessary to adjust the balance of air input by authorized and licensed technicians;
- △ Thread glue must be resistant to the action of liquefied petroleum gases.
- △ **Warning! Use soap water or testing instrument to test whether piping joint leaks or not before using, and forbid using an open flame to test!**

△ After installing completely, you should check gas supply pressure. Use a pressure gauge which is equipped with liquid (such as U-type pressure gauge, the minimum value is 0.1mbar) or a digital pressure gauge to test.

Steps are as following:

- Remove top panel, and needle type pressure joint screw arbor (Fig.1), then slip rubber tube of pressure gauge over needle type pressure joint;
- Start the equipment in accordance with the instructions, measuring gas supply pressure (dynamic pressure) in the work state;      Fig.1
- Access to the equipment if measured data within the limits of Table 1, otherwise, you will need to adjust gas pressure regulating valve or contact gas supplier to bargain;
- Unplug pressure gauge after you accomplish pressure testing, then install needle type pressure joint screw arbor. **Important: must screw joint screw arbor, to prevent gas escape!**

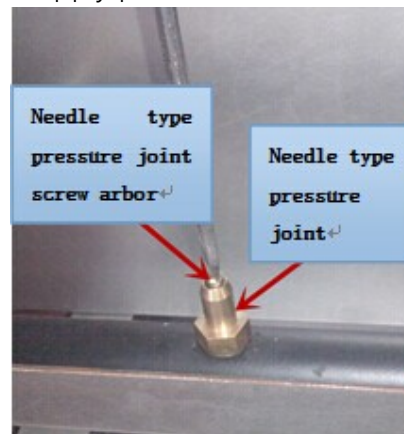

## 6.2. Debugging

It's very important to debug the new stove. Through the comprehensive system test of equipment, we can ensure function and safety performance of products. Discovering any potential problems before use (such as equipment's placement, ventilation, operation, etc), can avoid costly losses.

## 7. Safety Notices and Precautions

⚠ **Warning! For your safety, do not place petrol and other flammables nearby. Please keep clean and free of flammables surroundings. (Read ANSI Z83.14B, 1991 for reference)**

⚠ **Warning! Any erroneous installation, adjustment and refit may cause property damage or personal injury and maintenance failure. Read the instructions carefully before installation and using.**

⚠ **Warning! Operation instruction must be placed in a conspicuous location. When customers smell gas in the process of using, should take safety precautions immediately. Immediately turn off the main gas valve, extinguish all heat and flames, and call 911. Safety information can be obtained from your local gas suppliers.**

**When using this equipment, safety precautions should always be followed, including the following:**

⚠ The Heavy Duty Stock Pot Stove burners, cooking grates and outside surfaces may become hot after use, so you must be careful to touch;

⚠ During operation, do not directly touch burners and cooking grates;

⚠ Turn off the equipment as repairing, maintaining and cleaning;

⚠ If the equipment has any problems of equipment damage, gas piping leaks, igniter or valves damage, or lose product accessories, do not operate, and call for the service immediately;

⚠ The use of attachments not recommended or sold by the manufacturer may cause fire, personal injury or even death;

⚠ Do not use out of doors;

⚠ The equipment is used for cook, not available for any other use;

⚠ The equipment does not contain any user-serviceable parts. Dealers or technicians will repair it. Do not take apart any spare parts without authorization;

⚠ Never change any other parts without authorization to this equipment, otherwise, may cause hazards, and the manufacturer has the right not to provide warranty service;

⚠ Steel cutting producers used to manufacture with sharp edges. The

manufacturer has dealt with these sharp edges during production, however, we insist the operator take care when in contact with this piece of equipment;

- ⚠ Always keep hands, hair and clothing away from heating source.
- ⚠ Wait the unit cools down before cleaning. Because the unit is too hot to handle after using.

## 8. Operating Instructions

- ⚠ Before operating, make sure to place the unit horizontally by adjusting bottom adjustable legs, and place the catch tray properly.
- ⚠ The pilot light has been set at the factory. Each burner has a pilot light.

### 8.1. Lighting the pilot light

Turn the control valve at the position of "0"(Fig.2), make sure all knobs are in the close state. Light and hold an ignition source at the pilots. The pilot light may not be lighted immediately, for existing gas in the pipe. Wait a minute, the pilot light will be lighted after the gas extinguished.

Tips: You can use a screwdriver to adjust the height of the flame (Fig.3).

### 8.2. Igniting the main burner

Revolve the main fire control valve knob anticlockwise after lighting the pilot light, then the main fire burner is lighted by the pilot light. The power of burner increases as revolving angel increases. When knob reaches to " ", burner is in the maximum power (Fig.4).

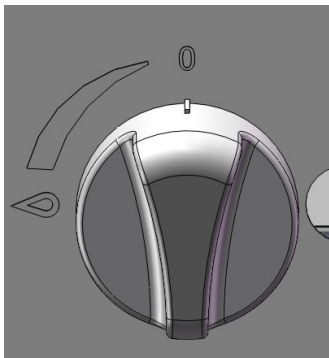

Fig.2



Fig.3

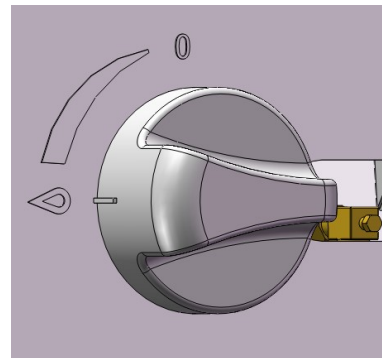

Fig.4

ATSP-18-1 CONTROL PANEL

ATSP-18-2 CONTROL PANEL

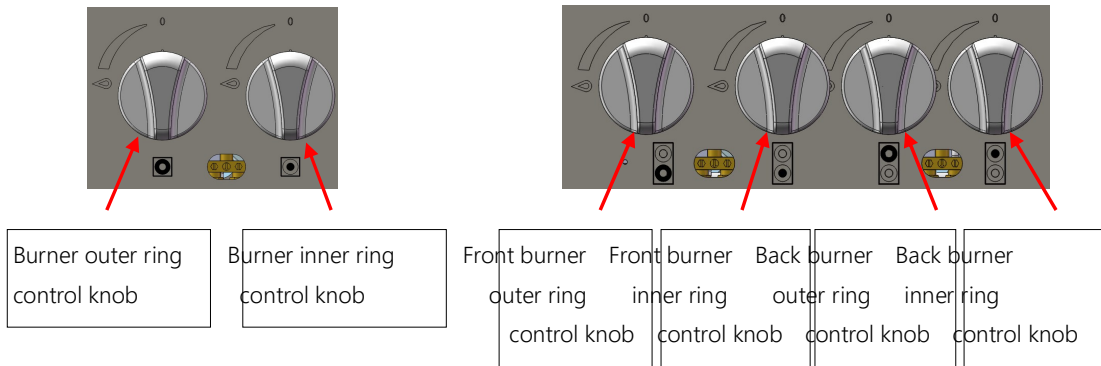

Fig.5

Fig.6

Reminder: Turn on the knob controlling inner ring burner first, then turn on the main fire valve, as shown in Fig.5, and 6.

- ⚠ Make sure air circulation at the bottom of equipment;
- ⚠ Do not use fan or air-conditioning blowing at the flame, in order to avoid extinguishing flame and cause safety accidents;
- ⚠ Install the matched cooking fume exhauster according as the local regulations over the char broiler;
- ⚠ Make sure to keep the air natural circulation in the kitchen.

### 8.3、 Turn off the valve

Revolve the control valve knob clockwise to "0" (Fig.1), so that extinguish flame of the main burner, but the pilot light still works.

After turn off the equipment, the main fire should be stop more than 5 minutes before next use.

### 8.4、 Stove Operation

Before using the stove for the first time, please use a mild detergent to wipe it clean. Do not use corrosive or abrasives detergent.

Turn the burners on about 15-20 minutes before broiling for preheating, according to the cooking requirement to adjust the flame size.

**Notice:** When first preheating, the furnace will smoke above. This is caused by protective lipids on the grates and other parts are heated, it is normal, and it will be eliminated after the power up to the maximum for burning an hour.

#### 8.5. Exchange main fire nozzle to switch gas source

Remove control panel, cooking grates, the pilot light head, and burner, remove main fire nozzle with proper open spanner, exchange nozzle of another gas source, then screw it (Fig.8). Reinstall burner, the pilot light head, cooking grates and control panel in proper order.

**⚠ Caution:** Each main fire orifice of the burner has been installed before delivery, normal use without adjustment but only switching gas. Adjust only by authorized and licensed technicians. When you converse the gas source, exchange the corresponding pressure maintaining valve which installed on air intake. See 5 in P18.

#### 8.6. Adjust air input

Remove control panel, unscrew damper solid screw(Fig.8), revolve damper left to right(Fig.9), meanwhile, observe flame, to adjust an appropriate opening degree. Then screw damper solid screw, make sure the equipment will not get loose in the process of moving and translation. Reinstall control panel.

**⚠ Caution:** Each burner damper has been adjusted before delivery (once air input), Normal use without adjustment but only switching gas. Adjust only by authorized and licensed technicians.



Fig.7



Fig.8

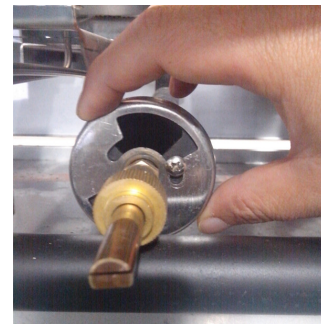

Fig.9

## 9. Cleaning and Maintenance

- ⚠ Do not use any abrasive or flammable detergent to wipe;
- ⚠ Do not hose down, immerse or pressure wash any part of the cooker, excluding the catch tray;
- ⚠ Do not use abrasive cleaning matters to wash, even not use corrosive detergent!
- ⚠ Warning: Before cleaning, all control valves must be turned off. Strictly follow the lighting instructions to work again after cleaning!
- ⚠ Warning: Wait for the equipment to cool down after the unit has been turned off before you clean!
- ⚠ Cut off the gas source when not in use;
- ⚠ If the equipment is not used for a long time, clean the surface by wiping it with a soft cloth and place it in a well-ventilated area;
- ⚠ Comprehensively check the equipment at least once every year by authorized and licensed technicians;
- ⚠ The product is made of 90% metals, and can not be discarded everywhere. Deal with it in accordance with the local codes.
- ⚠ Instructions to clean appliance regularly with recommended cleaning agents, if necessary.

### Recommended cleaning methods

<Table 2>

Items	Methods	Times
Body	Wipe it with a soft cloth and mild detergent;	daily
Control panel	Turn off valves when not in use; Wipe panel and control valve knob with mild detergent.	daily

Catch tray	<p>Pull out catch tray from front body until the equipment cools down. Use a cloth with cleaning agent to wipe unit surface, wipe up residue. Reinstall after cleaning.</p> <p><b>Warning: if the catch tray is permitted to fill too high, should be cleaned!</b></p>	Per use
------------	--	---------

## 10. Troubleshooting

<Table 3>

Problems	Possible causes	Problem solving
Not lighting	1. Insufficient gas pressure in pipe	1. Contact the local gas supply dept.
	2. Nozzle occlusion	2. Dredge nozzle
Ignite the pilot light but not the main fire	1. Insufficient gas pressure in pipe	1. Contact the local gas supply dept.
	2. The main fire nozzle occlusion	2. Dredge nozzle
	3. Gas control valves have problems	3. Change gas control valves
	4. The pilot light and the main fire's distance is too far	4. Adjust the distance of them
	5. Flame is too low	5. Adjust the height of

		the pilot light
Close gas and heard a sound of fire	1. Insufficient gas pressure in pipe	1. Contact the local gas supply dept.
	2. Not match nozzle aperture with gas resources	2. Adjust nozzle diameter
	3. Flow of connection pipe is not enough	3. Increase pipe's allowable flow
	4. Damper opening degree is too large	4. Adjust damper
Yellow flame and black smoke	1. Use bottom gas	1. Change gas
	2. Not match nozzle aperture with gas resources	2. Adjust nozzle diameter
	3. Not enough air to ignite	3. Increase damper opening degree
	4. In the peak of using gas, sources of gas float heavy	4. Turn down valves flow. Turn it up after the peak

The problems mentioned above are only for reference. If any fault occurs, please stop using, and contact technicians to check and repair. Safety first, turn off the power and gas supply before maintenance.

## 11. Spare Parts

- ⚠ The use of parts provided by other companies, our company has the right not to provide warranty service;
- ⚠ Order replacement parts from authorized representatives and after-sale service agency.
- ⚠ Provide the model number, serial number and description when you order components.

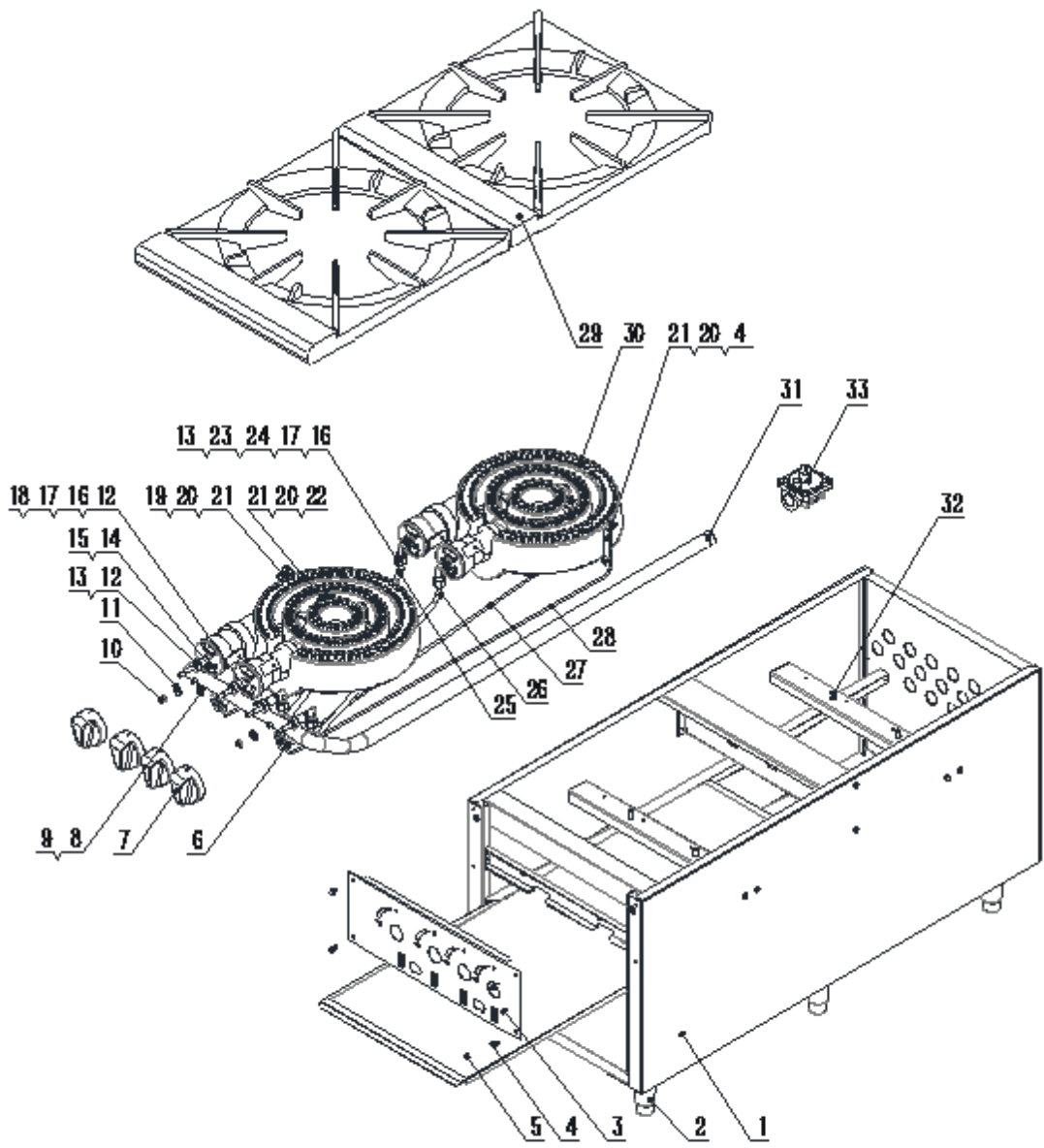

Fig.10

&lt;Table 4&gt;

No.	Matters Code	Component name	Qty	Dimensions (mm)/Model	Remark
1	21206001001	Body unit	1	457*515*432	ATSP-18-1
	21206002001			457*1045*432	ATSP-18-2
	21206003001			457*515*309	ATSP-18-1L
	21206004001			457*1045*309	ATSP-18-2L
2	301110001	Adjustable steel legs	4	Φ41.5*100	ATSP-18-1
			6		ATSP-18-2
			4		ATSP-18-1L
			6		ATSP-18-2L
3	21106001009 21106002011 21106001009 21106002011	Control panel	1	453*155	ATSP-18-1
					ATSP-18-2
					ATSP-18-1L
					ATSP-18-2L
4	301081006	Galvanized American outside six corner with pad tapping	6	ST4.8*12.5	ATSP-18-1
			8		ATSP-18-2
			6		ATSP-18-1L
			8		ATSP-18-2L
5	21106001010 21106002012 21106001010 21106002012	Catch tray	1	460*365*13	ATSP-18-1
				990*365*13	ATSP-18-2
				460*365*13	ATSP-18-1L
				990*365*13	ATSP-18-2L
6	301030007	Pilot light valve-double unit	1	AP6-1	ATSP-18-1
			2		ATSP-18-2
			1		ATSP-18-1L
			2		ATSP-18-2L

7	301140001	Kirsite knob	2		ATSP-18-1
			4		ATSP-18-2
			2		ATSP-18-1L
			4		ATSP-18-2L
8	301060001	Needle type pressure joint	1	1/8"-27NPT	ATSP-18-1/2/1L/2L
9	301060002	Needle type pressure joint screw arbor	1	M5*23	ATSP-18-1/2/1L/2L
10	301080002	Galvanized flange surface nut	2	M6	ATSP-18-1/2/1L/2L
11	301082002	Galvanized flat washer	2	Φ6.5*Φ18	ATSP-18-1/2/1L/2L
12	301030002	A18 stopcock	2	A18-318	ATSP-18-1
			4		ATSP-18-2
			2		ATSP-18-1L
			4		ATSP-18-2L
13	301040012	A18 nozzle NG32	2		ATSP-18-1
	301040013	A18 nozzle LP49	4		ATSP-18-2
	301040012	A18 nozzle NG32	2		ATSP-18-1L
	301040013	A18 nozzle LP49	4		ATSP-18-2L
14	301990006	Damper cover	2		ATSP-18-1
			4		ATSP-18-2
			2		ATSP-18-1L
			4		ATSP-18-2L
15	301081011	Stainless steel cross screws	2	M5*10	ATSP-18-1
			4		ATSP-18-2
			2		ATSP-18-1L
			4		ATSP-18-2L
16	301080007	Brass nut	0	M16	ATSP-18-1
			4		ATSP-18-2
			0		ATSP-18-1L
			4		ATSP-18-2L

17	301070011	Brass hoop	0	Φ10	ATSP-18-1
			4		ATSP-18-2
			0		ATSP-18-1L
			4		ATSP-18-2L
18	301050015	Brass street elbow	0	M16 turn to 3/8"-27UNS	ATSP-18-1
			2		ATSP-18-2
			0		ATSP-18-1L
			2		ATSP-18-2L
19	21106002013	Front burner outer pilot intake-tube	1	Φ4.7*0.6	ATSP-18-1/2/1L/2L
20	301060003	Pilot light head	2	A73007/TiP Φ 4.7	ATSP-18-1
			4		ATSP-18-2
			2		ATSP-18-1L
			4		ATSP-18-2L
21	211060001011	Pilot light head stator	2		ATSP-18-1
			4		ATSP-18-2
			2		ATSP-18-1L
			4		ATSP-18-2L
22	21106002014	Front burner inner pilot intake-tube	1	Φ4.7*0.6	ATSP-18-1/2/1L/2L
23	301080008	Brass lock nut	0	M18	ATSP-18-1
			2		ATSP-18-2
			0		ATSP-18-1L
			2		ATSP-18-2L
24	301050014	Brass double male elbow	0	M16 turn to 3/8"-27UNS	ATSP-18-1
			2		ATSP-18-2
			0		ATSP-18-1L
			2		ATSP-18-2L
25	21106002017	Back burner outer ring main gas pipe	0	Φ10*1.0	ATSP-18-1
			1		ATSP-18-2
			0		ATSP-18-1L
			1		ATSP-18-2L

26	21106002018	Back burner inner ring main gas pipe	0	Φ10*1.0	ATSP-18-1
			1		ATSP-18-2
			0		ATSP-18-1L
			1		ATSP-18-2L
27、 28	21106002015	Back burner pilot light in-take tube	0	Φ4.7*0.6	ATSP-18-1
			2		ATSP-18-2
			0		ATSP-18-1L
			2		ATSP-18-2L
29	301020013	Boiler cradle	1	Y-0008	ATSP-18-1
			2		ATSP-18-2
			1		ATSP-18-1L
			2		ATSP-18-2L
30	301010013	Boiler burner	1	Φ305*385	ATSP-18-1
			2		ATSP-18-2
			1		ATSP-18-1L
			2		ATSP-18-2L
31	301070014	18" single head broiler in-take tube	1	343*523*86	ATSP-18-1
	301070015	18" double head broiler in-take tube			ATSP-18-2
	301070014	18" single head broiler in-take tube			ATSP-18-1L
	301070015	18" double head broiler in-take tube			ATSP-18-2L
32	301081012	Galvanized flange screws	2	M8*16	ATSP-18-1
			4		ATSP-18-2
			2		ATSP-18-1L
			4		ATSP-18-2L

## 12. Accessories List

<Table 5>

Model Name Qty	ATSP-18-1	ATSP-18-2	ATSP-18-1L	ATSP-18-2L
Adjustable steel legs	4 pieces	6 pieces	4 pieces	6 pieces
pressure maintaining valve	1 piece	1 piece	1 piece	1 piece
A18 nozzle	2 piece	4 piece	2 piece	4 piece
instructions	1 piece	1 piece	1 piece	1 piece

**Notice:**

1. Pressure maintaining valve connects with air intake, must be installed by authorized and licensed technicians, to ensure interface tightness.
2. The pressure regulator(s) have connected, the maximum load of natural gas cannot exceed 6", and of LP cannot exceed 12".
3. Adjustment range of the pressure regulator(s) is 4"-6"for natural gas, and 7"-10"for L.P..
4. Screw the hex nut (Fig.11) before connect air intake, ensure gas mark (Fig.12) on the plastic core whether match with connected gas source, if not, then pull out the plastic core and change another head, insert it again. The same as exchanging gas source.
5. When exchange gas source, use the A18 orifice (Fig.13) in the accessories. Follow rules of 8.5.

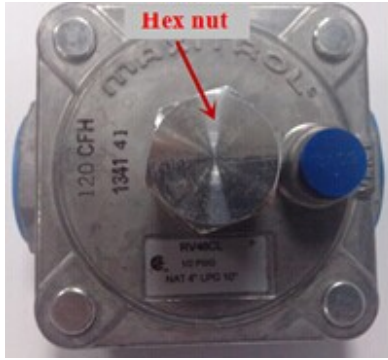

Fig.11



Fig.12



Fig.13



Conforms to ANSI STD Z83.11-2016  
 Certified to CSA STD 1.8-2016  
 Conforms to NSF/ANSI STD.4

Our products have the advantages of good durability and low maintenance charge. But to update some components and necessary maintenance, can prolong life length of the products. Contact the dealer for assistance. In order to avoid confusion, please follow the format in figure 10 and table 4.

