

Atlas Metal INDUSTRIES, INC.

Subsidiary of Mercury Aircraft, Inc.

1135 N.W. 159th DR., MIAMI, FL 33169
PHONE (305) 625-2451, (800) 762-7565, FAX (305) 623-0475, E-mail: sales@atlasfoodserv.com

PARTS LIST FOR MECHANICAL WATER STATION WSM

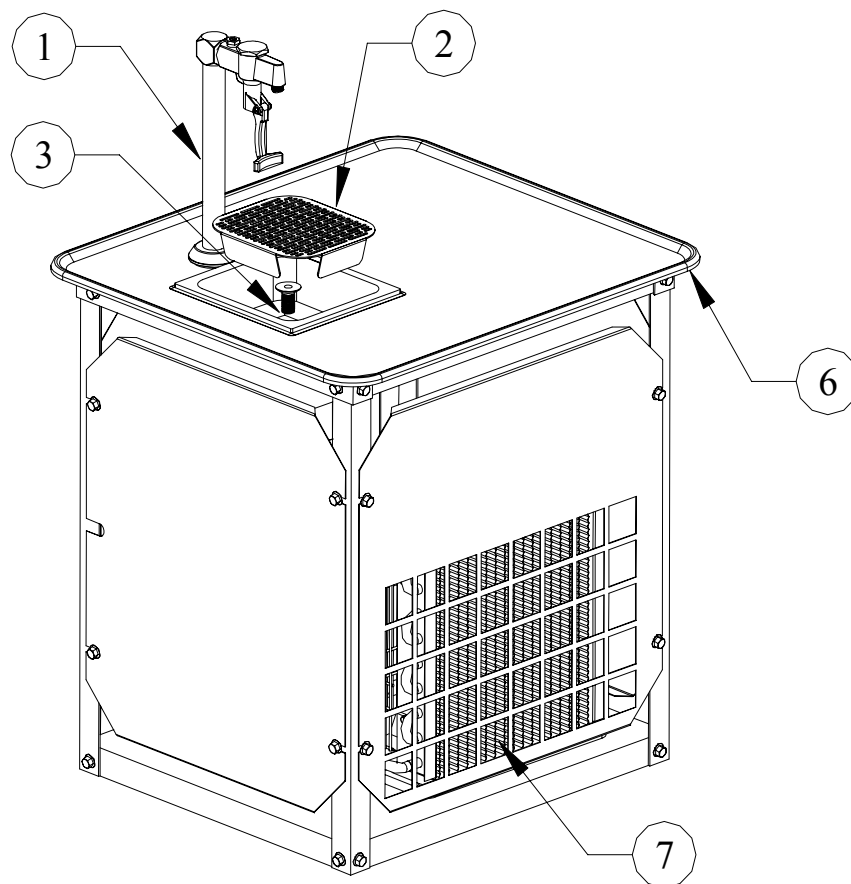

ITEM NUMBER	PART NUMBER	DESCRIPTION
1	3020-1	Faucet
2	S81806-0	Splash Guard
3	3018-0	Plastic Drain
4	4710-2	Washer (Not Shown)
5	2050-2	Nut (Not Shown)
6	7002-0+Model #	Vinyl Bead Gasket
7	2006-4	1/4 H.P. Compressor
8	1003-0	Power Cord (Not Shown)
9	2028-0	0.044 Cap Tube (Not Shown)
10	2023-0	Drier (Not Shown)
11	2040-0	Thermostat (Not Shown)

MECHANICAL WATER STATION

WSM

INSTALLATION

Provide a 16" x 18" cut-out in the counter top and drop the unit in. The vinyl gasket assures complete seating. A non-toxic silicone seal may be used between the gasket and counter top (not required). The unit should be level for draining purposes. When installing in a counter, it is recommended that the operator side be completely open for air circulation. When this is not possible, such as in an island counter, it is recommended that two grill openings be provided approximately 18" x 18" of free air for intake and exhaust at opposite ends of the counter. The unit is supplied with a power cord and a NEMA plug. Refer to the data plate on the compressor housing for the amperage and voltage information. Use a licensed electrician when installing power source. After connecting the plumbing the unit is ready to use. It is recommended that the air be purged from the water system before using.

OPERATION

The WSM is ready to use approximately 45 minutes after it is plugged in. The unit has been pre-tested and set for proper operation.

MAINTENANCE

NEVER CLEAN METAL WITH A CHLORIDE BASED PRODUCT. CHLORIDES OR IMPROPER CLEANING COULD SCAR, MARK AND/OR CORRODE PANS. **DO NOT** USE STEEL WOOL OR ABRASIVE PRODUCTS. TO CLEAN USE SOAPY WARM WATER, RINSE THOROUGHLY TO REMOVE ALL RESIDUES. CLEAN CONDENSER COIL REGULARLY. **FAILURE TO MEET THESE CONDITIONS WILL VOID WARRANTY.**