



Subsidiary of Mercury Aircraft, Inc.

1135 N.W. 159th DR., MIAMI, FL 33169

PHONE (305) 625-2451, (800) 762-7565, FAX (305) 623-0475, E-mail: sales@atlasfoodserv.com

PARTS LIST FOR HEATED CONDIMENT RAIL WCPH

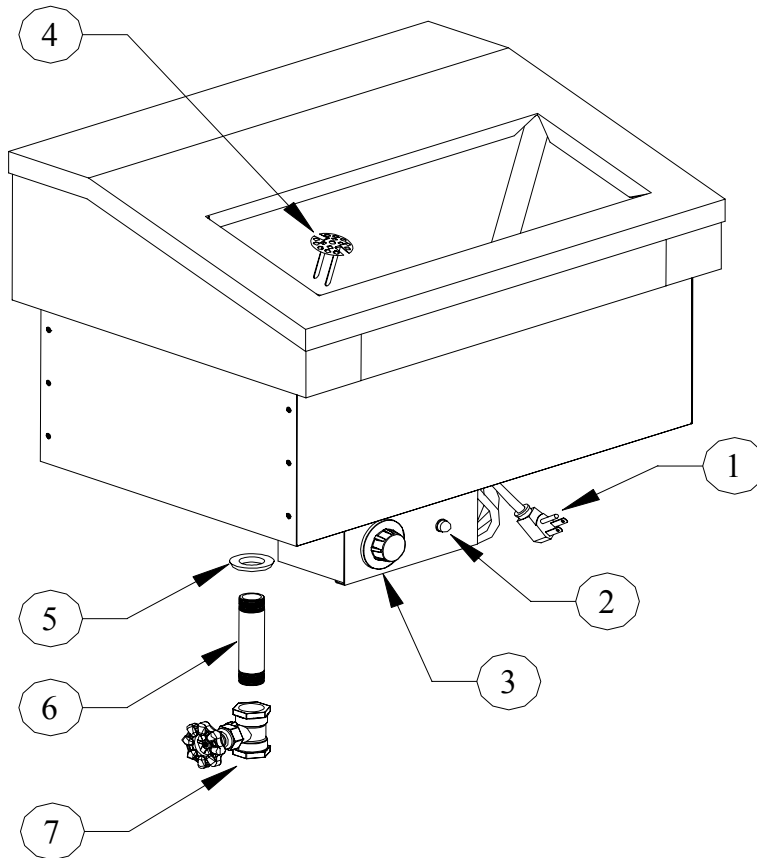

ITEM NUMBER	PART NUMBER	DESCRIPTION
1	1002-0	Power Cord
2	1099-0	Pilot Light
3	1097-0	Dial
4	86-3202	Perforated Snap-In Drain
5	49-1028	Grommet
6	3006-2	3/4 X 4 Brass Nipple
7	3016-1	3/4 Gate Valve
8	111-1040	Heating Element (Not Shown)
9	2040-0	Thermostat (Not Shown)

HEATED CONDIMENT RAIL

WCPH

INSTALLATION

Provide a 14 3/4 x 21 7/8 cut-out in the counter top and drop the unit in.

A non-toxic silicone sealer may be used between the flange and counter top (not required).

The unit is supplied with a power cord and a NEMA plug. Refer to the data plate located on the control box for the amperage and voltage information. Use a licensed electrician when installing power source.

OPERATION

The unit is ready to operate as soon as it is plugged in. The thermostat has an off position and numbers from 1 through 10 (number 10 is the highest).

MAINTENANCE

NEVER CLEAN PANS WITH A CHLORIDE BASED PRODUCT. CHLORIDES OR IMPROPER CLEANING COULD SCAR, MARK AND/OR CORRODE PANS. **DO NOT** USE STEEL WOOL OR ABRASIVE PRODUCTS. TO CLEAN USE SOAPY WARM WATER, RINSE THOROUGHLY TO REMOVE ALL RESIDUES. **FAILURE TO MEET THESE CONDITIONS WILL VOID WARRANTY.**