

ARCTIC AIR

Factory Parts Catalog



Product No.	F22CWF4
Series	134A
Color	white
Volts	115
Owner's Guide	297121700
Market	private label

 **Electrolux**

Electrolux Major Appliances
North & Latin America
P.O. BOX 212378
AUGUSTA, GA 30917

Publication No.
5995518270
08/07/07
(EN/SERVICE/MLR)
365

UPRIGHT FREEZER

Model No.
F22CWF

Copyright © 2008 Electrolux Home Products, Inc.
All rights reserved.

DOOR

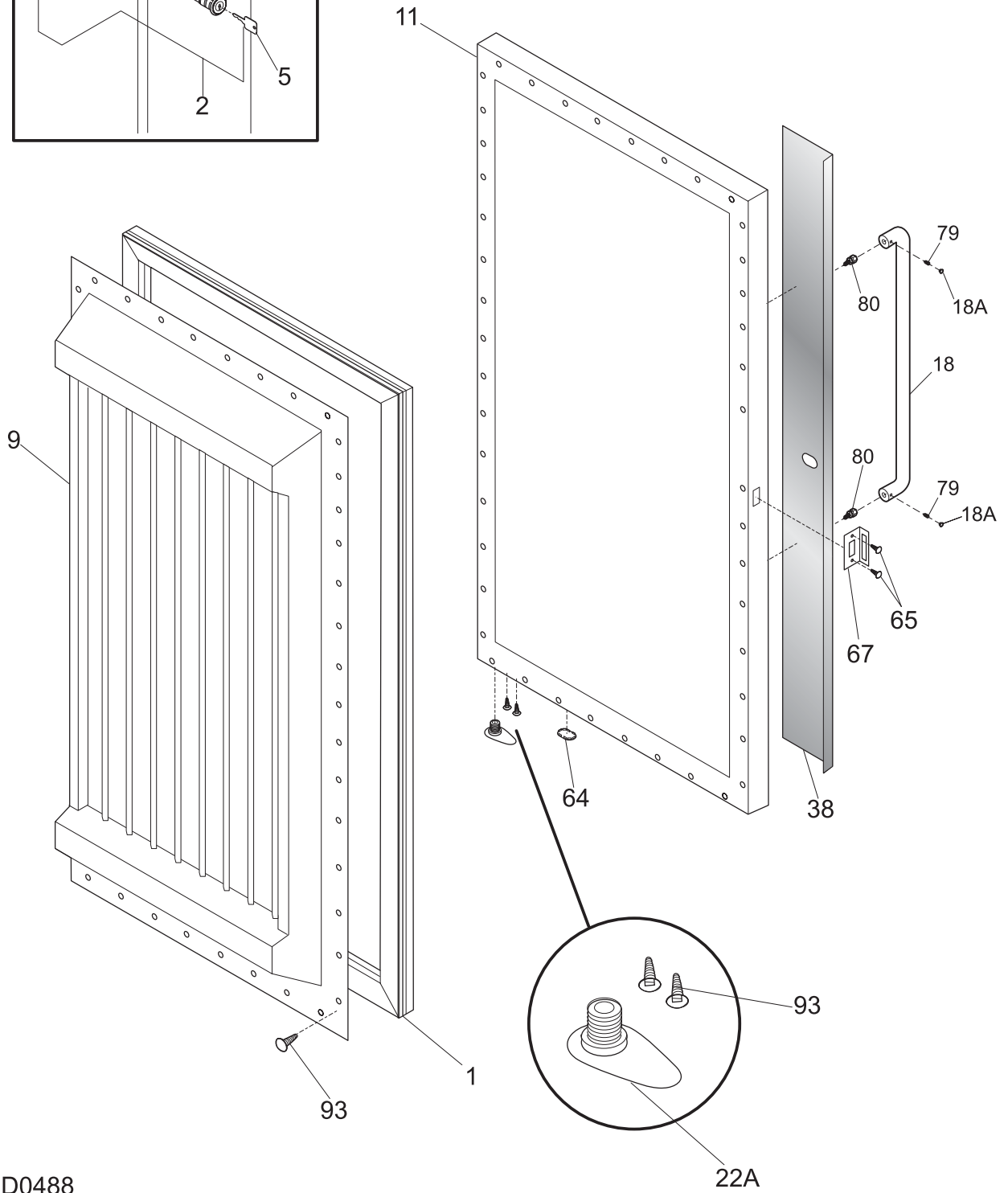
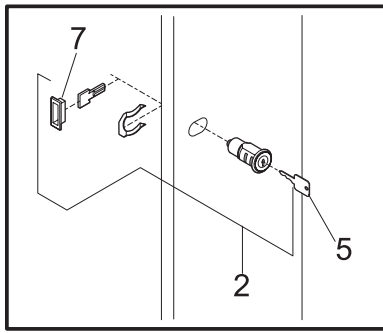

P08D0488

DOOR

POS. NO	PART NO.	DESCRIPTION
1	216522315	Gasket-door, gray
2 #	216362700	Lock Assy
5 #	216362800	Key, lock
7	216468700	Bezel-lock
9	216529700	Panel-inner door
11	297255300	Panel-outer door, white
18	297082700	Handle, stainless
*	240537301	Nut-anchor, door hdl screw
18A	297083500	Plug-handle
22A	216335400	Bearing-hinge
38	297129700	Trim, door
64	216403700	Plug-button, hole filler, door base
65	216423501	Screw-retainer
67	216423000	Retainer-lock
79	218755402	Screw-set, 10-32 x 0.375
80	218755504	Screw-shoulder, #10 AB, handle mounting
93	5304460605	Screw, ph truss head, 8-18AB x 0.500
*	240578902	Screw, hex head, 1/4-20 x 5/8

CABINET

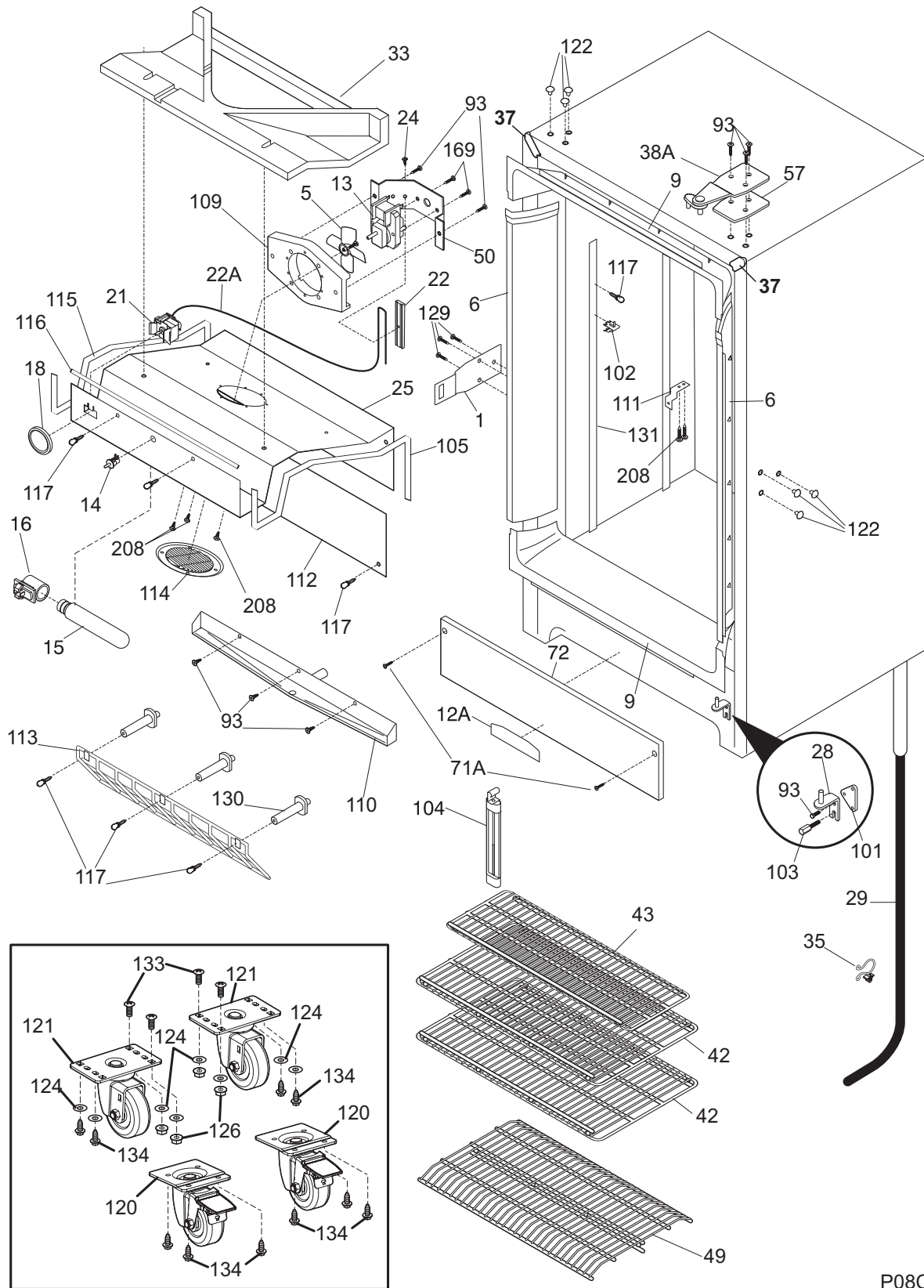

P08C1135

CABINET

POS. NO	PART NO.	DESCRIPTION
1	297222500	Lock-catch
5 #	216325600	Fan Blade
6	297200900	Breaker Kit w/corners
9	297200100	Breaker Kit w/corners, 32", top and bottom
12A	216734500	Nameplate
13 #	216914200	Motor, fan, 115 V
14	216472300	Switch-light plunger
15	216518100	Light Bulb/Lamp
16	216817601	Socket, light/lamp, 25 W
18	216591500	Knob, temp control
21	216579100	Control-temperature, NSF
22	216823500	Clamp, cap tube, cold control
22A	5303916855	Tube, sensor sleeve, plastic, clear
24	5304460604	Screw, type A, 10-24 x 3/8
25	216659102	Cover-evaporator
*	297090800	Label, freezer
* #	297069300	Harness, electrical, evaporator
28	216335600	Hinge-bottom, stepped pin
29	216361901	Hose-drain
33	216680901	Duct-air
35	216273000	Clip, drain hose
37	241611301	Trim-cabinet corner, white, (2)
38A	297215900	Hinge-top, door closer
38A*	297242900	Hinge, assy, LH, w/instructions
42	216384000	Shelf-full frame, wire, (2)
43	216386200	Shelf-partial, wire
49	216331800	Trivet
50	08013207	Bracket-fan motor
57	216335500	Spacer-hinge, top
71A	216395801	Screw, 1/4 20 x 1/2
72	216330500	Grille/Kickplate
93	5304460605	Screw, ph truss head, 8-18AB x 0.500
101	216335700	Plate-hinge, tapping
102	297121900	Support shelf
103	216336301	Standoff-base panel
103*	297146800	Screw, 8-18AB x 0.470
104	216360600	Thermometer
105	216361100	Gasket-cover evap, RH
109	297014200	Venturi, blower
110	216377000	Pan-drain, condensate
111	297141400	Bracket-evap cover
111*	3017666	Nut-insert
112	216381300	Cover-drain, condensate
113	216383600	Grate-air intake
114	297014300	Cover-blower
115	216383700	Gasket-evap cover, LH
116	216383800	Gasket-evap cover, front
117	216605500	Thumbscrew
120	297206600	Caster-front, (2)
121	297206500	Caster-rear, (2)
122	216429601	Plug, white

CABINET

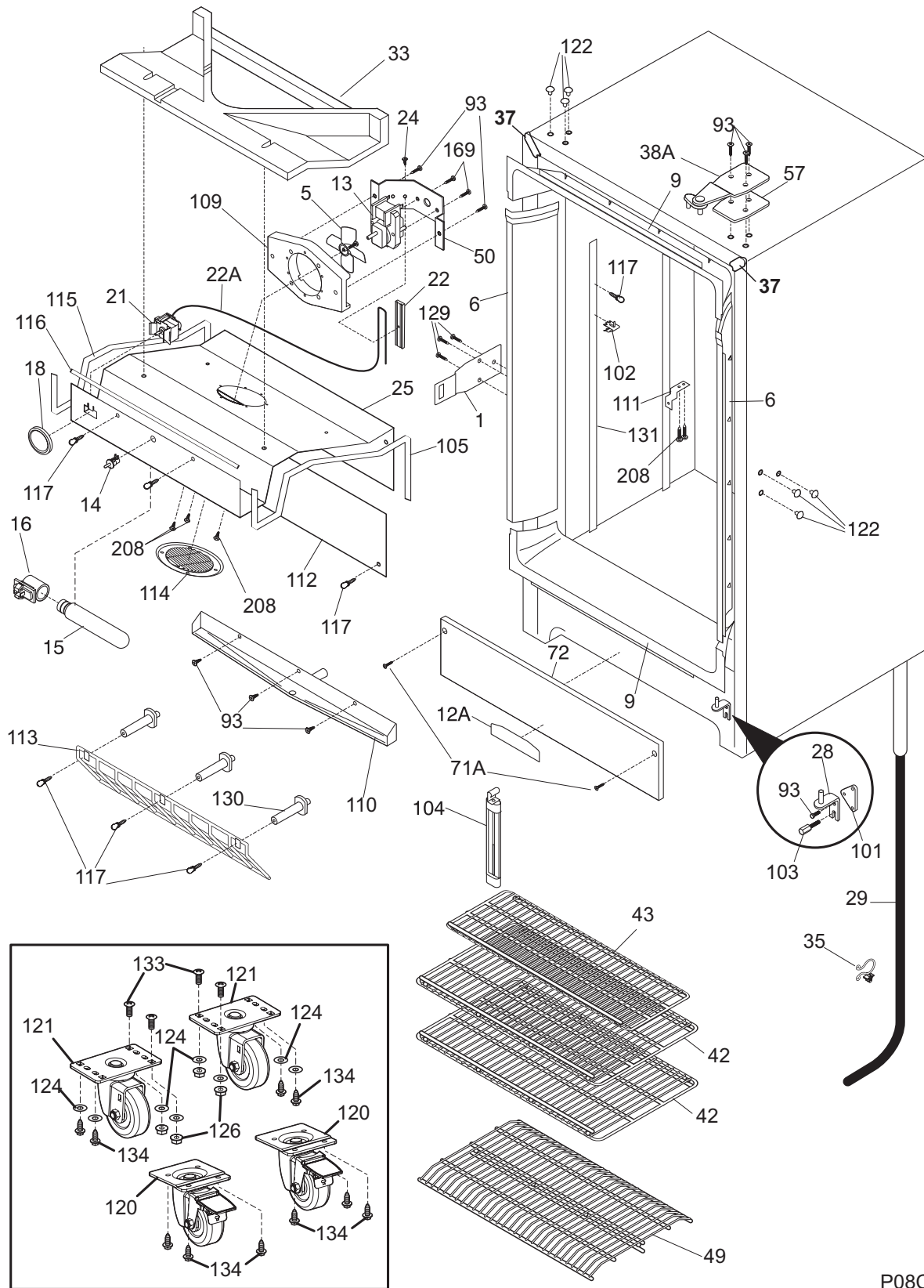

P08C1135

CABINET

POS. NO	PART NO.	DESCRIPTION
124	216658501	Washer, (4)
126	216658601	Nut, lock, 5/16 UNC-3B
129	216393301	Screw-lock catch, one way
130	297244700	Support, evaporator mtg
131	297122000	Shelf-standard
133	216658400	Bolt, caster, 5/16 sq. neck, front
134	240578902	Screw, hex head, 1/4-20 x 5/8
169	216912401	Screw, hex washer head, 8-32 x 0.500, bracket fan mtr, (2)
208	216504500	Screw, AB, 8-18x.500
*	297001708	Insulation, drain tube, 36"
*	5303311565	Clip-cable
*	297256300	Kit, hardware caster
*	297211400	Installation Instructions, casters

SYSTEM

POS. NO	PART NO.	DESCRIPTION
1	297152201	Condenser
2	5308000110	Strap-evap/heater, aluminum, (2)
4	216987500	Drier-filter
5 #	297170600	Harness-main
5*	216987800	Adapter-harness
*	297082300	Harness-jumper
14	216730700	Heater-defrost
15 #	297052900	Evaporator
15A	297219100	Heat Exchanger
18	297078700	Insulator-evap, styrofoam
19	297078800	Insulator-evap, styrofoam
20	216872200	Thermostat, defrost
23 #	216744500	Timer-defrost
24	216968501	Bracket-timer
24A	297207900	Guard, timer
27	297102900	Grommet, compressor
29 #	216966900	Compressor, assy
30 #	216894200	Starter, relay
31	297165801	Pan-drain
31A#	216100126	Overload Protector
41	297070700	Cover-wiring, rear
53	216894500	Cover-terminal
55	216985005	Capacitor-run
60	241584301	Motor-condenser fan
61	241639501	Blade-condenser fan
64	216578800	Vent
65	5309950074	Valve, breather
86	216036601	Screw, RWHD, 8-32A x 0.500, GX-CA
87	5304463290	Screw, hi-lo blunt, #8-18X1/2
93	5304460605	Screw, ph truss head, 8-18AB x 0.500
107	297225500	Cover, access
130	297244700	Support, evaporator mtg
136	240405201	Grommet, rubber, black, cond tube/wire
*	240491503	Screw-compressor mtg, 1/4-28 x 1.16, (4)
138	297070800	Cover-drain hose
146	297164000	Shroud-fan orifice
146*	216337701	Screw, HWH, 10-24 x 0.500, Swage
*	240555002	Screw-#8-32 X 3/8
*	297102800	Spacer-tube
*	297111000	Standoff
* #	297169900	Cord-power, flat
*	216225700	Grommet-spacer