



**INSTALLATION AND OPERATING INSTRUCTIONS**

**HOTROD<sup>®</sup> ROLLER GRILLS**  
**SLANTED HOTROD<sup>®</sup> ROLLER GRILLS**  
**FULL MENU HOTROD<sup>®</sup> ROLLER GRILLS**

**Model Numbers: HRDi & HRSDi -20, -31, -50, -45, -75 & -85 (S, W, R)**

**INTENDED FOR OTHER THAN HOUSEHOLD USE**  
**RETAIN THIS MANUAL FOR FUTURE REFERENCE**  
**UNIT MUST BE KEPT CLEAR OF COMBUSTIBLES AT ALL TIMES**

**IMPORTANT FOR FUTURE REFERENCE**

Please complete this information and retain this manual for the life of the equipment. For Warranty Service and/or Parts, this information is required.

\_\_\_\_\_   
Model Number

\_\_\_\_\_   
Serial Number

\_\_\_\_\_   
Date Purchased



**WARNING:** For your safety do not store or use gasoline or other flammable vapors or liquids in the vicinity of this or any other appliance. Keep the area free and clear of combustibles. (See ANZI Z83.14B, 1991)



**WARNING:** Improper installation, adjustment, alteration, service or maintenance can cause property damage, injury or death. Read the Installation, Operating and Maintenance Instructions thoroughly before installing or servicing this equipment.



P/N 8893926 Rev B 3/13

**APW WYOTT Foodservice Equipment Company**

P.O. Box 1829  
Cheyenne, WY 82003

+1 (307) 634-5801 Phone  
+1 (307) 637-8071 Fax

+1 (800) 752-0863 Toll Free  
[www.apwwyott.com](http://www.apwwyott.com)



APW Wyott takes pride in the design and quality of our products. When used as intended and with proper care and maintenance, you will experience years of reliable operation from this equipment. To ensure best results, it is important that you read and follow the instructions in this manual carefully. Installation and start-up should be performed by a qualified installer who thoroughly read, understands and follows these instructions.



If you have questions concerning the installation, operation, maintenance or service of this product, write Technical Service Department APW/Wyott Foodservice Equipment Company, P.O. Box 1829, Cheyenne, WY 82003.



## SAFETY PRECAUTIONS



Before installing and operating this equipment be sure everyone involved in its operation is fully trained and is aware of all precautions. Accidents and problems can result by a failure to follow fundamental rules and precautions.

The following words and symbols, found in this manual, alert you to hazards to the operator, service personnel or the equipment. The words are defined as follows.

 **DANGER:** This symbol warns of imminent hazard which will result in serious injury or death. 

 **WARNING:** This symbol refers to a potential hazard or unsafe practice, which could result in serious injury or death. 



 **NOTICE:** This symbol refers to information that needs special attention or must be fully understood, even though not dangerous. 



 **CAUTION:** This symbol refers to a potential hazard or unsafe practice, which may result in minor or moderate injury or product or property damage. 



---

---

 **WARNING:** Improper installation, adjustment, alteration, service or maintenance can cause property damage, injury or death. Read the Installation, Operating and Maintenance Instructions thoroughly before installing or servicing this equipment. 

 **WARNING: SHOCK HAZARD** – Do not open any panels that require the use of tools. 

 **CAUTION:** These models are designed, built and sold for commercial use. If these models are positioned so the general public can use the equipment, make sure that cautions, warnings and operating instructions are clearly posted near each unit so that anyone using the equipment will use it correctly and not injure themselves or harm the equipment. 

 **NOTICE:** The unit, when installed must be electrically grounded and comply with local codes, or in the absence of local codes, with the national electrical code ANSI/NFPA70-latest edition. Canadian installation must comply with CSA-STANDARD C.22.2 Number 0 M1982 General Requirements-Canadian Electrical Code Part II, 109-M1981-Commercial Cooking Appliances. 

**CAUTION:** Maintenance & Repair should be handled by a factory authorized agent. Before doing any maintenance or repair, contact APW Wyott.

**WARNING:** Disconnect device from electrical power supply and place a Tag Out-Lockout on the power plug, indicating you are working on the circuit.

**WARNING:** Check the data plate on this unit before installation. Connect the unit only to the voltage and frequency listed on the data plate. Connect only to 1 or 3 phase as listed on data plate.

**NOTICE:** Install according to the spacing requirements listed in the installation section of this manual. We strongly recommend having a competent professional install this equipment. A licensed electrician should make the electrical connections and connect power to the unit. Local codes should always be used when connecting these units to electrical power. In the absence of local codes, use the latest version of the National Electrical Code.

**NOTICE:** Local codes regarding installation vary greatly from one area to another. The National Fire Protection Association, Inc. states in its NFPA96 latest edition that local codes are "Authority Having Jurisdiction" when it comes to requirement for installation of equipment. Therefore, installation should comply with all local codes.

## CONTENTS

<u>Description</u>	<u>Page</u>	<u>Description</u>	<u>Page</u>
Safety Precautions _____	2	Parts Lists & Exploded Views _____	11
Specifications _____	4	HR(S)Di-31 & 50 _____	11
General Installation Instructions _____	5	HR(S)Di-31 (Parts List) _____	12
Installation _____	6	HR(S)Di-50 (Parts List) _____	12
Cleaning _____	6	Wiring Diagrams _____	13
Service _____	7	Warranty _____	15
Operation _____	8		
Programming _____	10		
Factory Settings _____	10		

### Location of Data Plate

The data plate for the Hot Rod is located on the back of the unit.

### Immediately Inspect for Shipping Damage

All containers should be examined for damage before and during unloading. The freight carrier has assumed responsibility for its safe transit and delivery. If equipment is received damaged, either apparent or concealed, a claim must be made with the delivering carrier.

- A) Apparent damage or loss must be noted on the freight bill at the time of delivery. It must then be signed by the carrier representative (Driver). If this is not done, the carrier may refuse the claim. The carrier can supply the necessary forms.
- B) Concealed damage or loss if not apparent until after equipment is uncrated, a request for inspection must be made to the carrier within 15 days. The carrier should arrange an inspection. Be certain to hold all contents and packaging material.

Installation and start-up should be performed by a qualified installer who thoroughly read, understands and follows these instructions.

## SPECIFICATIONS



<b>Standard Models (HR, HRS / Flat, Slant)</b>					
<b>Model</b>	<b>Voltage</b>	<b>Amps</b>	<b>Width</b>	<b>Depth</b>	<b>Height</b>
HR(S)Di-20	120	6.4	17-1/4"	18-5/8"	9-1/8"
HR(S)Di-20S	120	6.4	17-1/4"	18-5/8"	11-3/4"
HR(S)Di-31	120	8.2	23-3/4"	18-5/8"	9-1/8"
HR(S)Di-31	208	5.6	23-3/4"	18-5/8"	9-1/8"
HR(S)Di-31	240	6.5	23-3/4"	18-5/8"	9-1/8"
HR(S)Di-31S	120	8.2	23-3/4"	18-5/8"	11-3/4"
HR(S)Di-31S	208	5.6	23-3/4"	18-5/8"	11-3/4"
HR(S)Di-31S	240	6.5	23-3/4"	18-5/8"	11-3/4"
HR(S)Di-45	120	11.7	23-3/4"	29-9/16"	10-7/8"
HR(S)Di-45	208	8.1	23-3/4"	29-9/16"	10-7/8"
HR(S)Di-45	240	9.4	23-3/4"	29-9/16"	10-7/8"
HR(S)Di-50	120	11.9	34-3/4"	18-5/8"	9-1/8"
HR(S)Di-50	208	6.1	34-3/4"	18-5/8"	9-1/8"
HR(S)Di-50	240	7.1	34-3/4"	18-5/8"	9-1/8"
HR(S)Di-50S	120	11.9	34-3/4"	18-5/8"	11-3/4"
HR(S)Di-50S	208	6.1	34-3/4"	18-5/8"	11-3/4"
HR(S)Di-50S	240	7.1	34-3/4"	18-5/8"	11-3/4"
HR(S)Di-75	120	8.7 (+)	34-3/4"	29-9/16"	10-7/8"
HR(S)Di-75	208	9.0	34-3/4"	29-9/16"	10-7/8"
HR(S)Di-75	240	10.4	34-3/4"	29-9/16"	10-7/8"
HR(S)Di-85	208	10.1	34-3/4"	29-9/16"	10-7/8"
HR(S)Di-85	240	11.6	34-3/4"	29-9/16"	10-7/8"
<b>Wide Roller Spacing Models (W)</b>					
<b>Model</b>	<b>Voltage</b>	<b>Amps</b>	<b>Width</b>	<b>Depth</b>	<b>Height</b>
HR(S)Di-20W	120	5.9	17-1/4"	18-5/8"	9-1/8"
HR(S)Di-20SW	120	5.9	17-1/4"	18-5/8"	11-3/4"
HR(S)Di-31W	120	7.5	23-3/4"	18-5/8"	9-1/8"
HR(S)Di-31W	208	5.1	23-3/4"	18-5/8"	9-1/8"
HR(S)Di-31W	240	5.9	23-3/4"	18-5/8"	9-1/8"
HR(S)Di-31SW	120	7.5	23-3/4"	18-5/8"	11-3/4"
HR(S)Di-31SW	208	5.1	23-3/4"	18-5/8"	11-3/4"
HR(S)Di-31SW	240	5.9	23-3/4"	18-5/8"	11-3/4"
HR(S)Di-50W	120	10.8	34-3/4"	18-5/8"	9-1/8"
HR(S)Di-50W	208	5.6	34-3/4"	18-5/8"	9-1/8"
HR(S)Di-50W	240	6.4	34-3/4"	18-5/8"	9-1/8"
HR(S)Di-50SW	120	10.8	34-3/4"	18-5/8"	11-3/4"
HR(S)Di-50SW	208	5.6	34-3/4"	18-5/8"	11-3/4"
HR(S)Di-50SW	240	6.4	34-3/4"	18-5/8"	11-3/4"



(+ ) 2 power cords



# GENERAL INSTALLATION INSTRUCTIONS

This unit has been inspected at the factory prior to shipment.

Unpack the unit and remove all packing materials. Place on a flat horizontal surface at the desired location.

 **WARNING:** Check the data plate on this unit before installing. Connect the unit only to the voltage and frequency listed on the data plate. Connect only to 1 or 3 phase as listed on the data plate. 

 **WARNING: IMPROPER GROUNDING COULD RESULT IN ELECTRICAL SHOCK!** This appliance is equipped with a three prong (grounded) plug for your protection against electrical shock hazard and should be plugged directly into a properly grounded three receptacle. Do not cut or remove the grounding prong from this plug. 

 **CAUTION:** Do not use ordinary steel wool as any particles left on the surface will rust. 

*NEVER USE* a wire brush, steel or abrasive scouring pads (except stainless), scraper, file or other steel tools. Surfaces which are marred collect dirt more rapidly and become more difficult to clean. Marring also increases the possibility of corrosive attack.

*NEVER* use any corrosive cleaner. Use only cleaners approved for stainless steel.

*NEVER* use cleaning solvents with a hydrocarbon base.

## GENERAL INSTALLATION:

1. Always clean equipment thoroughly before first use. (See general cleaning instructions)
2. Check ratings label for your model designation and electrical ratings.
3. For best results, use stainless steel countertops.
4. Attach legs to unit.

## GENERAL OPERATING INSTRUCTIONS:

1. Trained personnel should operate all food service equipment.
2. Do not allow your customers to come into contact with any surface labeled "CAUTION HOT"
3. Where applicable, never pour cold water into dry heated units.
4. NEVER hold food below 140°F.

## GENERAL CLEANING INSTRUCTIONS:

1. Never clean any electrical unit by immersing it in water. Turn the unit off and allow it to cool before surface cleaning.
2. Always clean equipment thoroughly before first use. Clean unit daily. Except where noted on charts: use warm soapy water. Mild cleansers and plastic scouring pads may be used to remove baked-on food and water scale on metal unit. NOTE: do not clean roller tubes with abrasive cleaners or scouring pads. Follow instructions on page 7.
3. Unplug electrical unit before cleaning or servicing. All service should be performed by an APW Wyott authorized service agency.

## **GENERAL TROUBLESHOOTING:**

### ***ALWAYS ASK AND CHECK:***

1. Is the unit connected to a live power source?
2. Check the circuit breaker.
3. Is power switch on and pilot light glowing?
4. Check the rating label. Are you operating unit on the proper voltage?

If the above checks out and you still have problems, call an APW Wyott authorized service agency.

## **INSTALLATION**

Place the HOTROD<sup>®</sup> directly on a countertop or on a matching APW Wyott Bun Warmer or Bun Cabinet (available separately). Place the unit close to an AC outlet, of the correct voltage, to avoid undue strain on the power cord.

**CAUTION:** To avoid equipment damage, make certain that the nameplate voltage is the same as the outlet voltage.

If the plug is to be removed and replaced with a plug more suitable for your area, the color code for the power cable is:

Neutral (N) = White or Blue   Live (I) = Black or Brown   Earth (E) = Green or Yellow/Green

After a suitable location has been chosen, wipe the rollers and the drip pan with a damp cloth. The unit is ready for use.

## **CLEANING**

### **DAILY CLEANING INSTRUCTIONS:**

1. Heat the unit.
2. Using a moist cloth filled with crushed or flaked ice, wipe each tube. Wipe the tubes from each end to the center. This will keep as much of the loosened particles out of the bearings as possible. Extend the cloth as far as possible between the rollers.
3. Next, wipe clean with another cloth. Continue to wipe from the end of the rollers to the center. This will reduce the grease and particles getting into the bearings and drive mechanism. This will extend the life of the unit and extend the period between routine maintenance of the drive mechanism.

**CAUTION:** NEVER use abrasive powders or pads; these cleaners may damage the roller finish. Also, the particles may get into the drive mechanism shortening the unit life.

4. Remove the drip pan and wash it in hot, soapy water, then rinse.
5. If stains are still present, add a light detergent to the cloth and repeat.
6. Replace the pan and turn the unit off if the grill will not be immediately used.

Alternate cleaning method using optional 3M sponge (#21807305) and handle (#21807300):

1. Turn heat down to lower setting (i.e. “hold” temperature) and allow grill to cool.
2. If the grill has considerable grease build-up, wipe the excess grease from the rollers with a lint free towel or paper towel before using the soap sponge.
3. Place sponge onto cleaning handle.
4. Immerse sponge in warm, soapy water.
5. Scrub rollers starting from the outside of the roller working your way to the center. Rinse sponge and re-wet with the soapy solution as needed.
6. Ensure that entire roller surface is cleaned.
7. Dry with lint free towel or paper towel.

**NOTE:** Cleanup will be faster if the product is specifically made for cooking on roller grills. Several meat packers now offer this product. For high-volume applications or from products that have a high sugar or fat content, the HOTROD<sup>®</sup> may require more frequent cleaning. For longer life of your HOTROD<sup>®</sup>, follow instructions for periodic cleaning throughout the day.

#### **PERIODIC CLEANING THROUGHOUT THE DAY:**

1. For high-volume applications or for product that has a high fat content, clean rollers every 3-4 hours.
2. Clean by removing the product from the rollers and wiping with a damp cloth from outside end of the rollers to the center. Replace the product and continue cooking. There should be no need to turn off the heat when wiping down the rollers. But care should be taken not to bring hands into direct contact with the rollers as burn could result.

**NOTE: THIS APPLIANCE SHALL NOT BE CLEANED WITH A WATER JET.**

## **SERVICE**

Service work should be performed only by a qualified technician who is experienced in and knowledgeable with the operation of commercial gas, electric and steam cooking equipment. Contact the Authorized Service Agency for reliable service, dependable advice or other assistance and for genuine factory parts.

**IF THE SUPPLY CORD IS DAMAGED, IT MUST BE REPLACED BY THE MANUFACTURER, ITS SERVICE AGENT OR A SIMILARLY QUALIFIED PERSON IN ORDER TO AVOID A HAZARD.**

## PROGRAMMING MODE:

1. Readout must display “- - - -“ to enter Programming Mode.
2. When “- - - -“ is displayed, Press & Hold the Settings button, then immediately press & hold either the Front Zone (+) Button or Back (-) Zone Button.
  - a. Only one zone can be programmed at a time, the following instructions are identical for each zone.
3. The appropriate zone indicator will flash and the “Cook” indicator will flash
  - a. The Cook Power setting will be displayed on the readout, default is 100%. Use the (+) or (-) buttons to change the Cook Power.
  - b. Press the Settings button.
  - c. The Cook Time setting will be displayed on the readout, default is 15 min. Use the (+) or (-) buttons to change the Cook Time.
  - d. Press the Settings button.
  - e. The Hold Power setting will be displayed on the readout, default is 45%. Use the (+) or (-) buttons to change the Hold Power.
  - f. Press the Settings button.
  - g. The Hold Time setting will be displayed on the readout, default is 2 hours. Use the (+) or (-) buttons to change the Hold Time.
  - h. Press the Settings button to exit Programming mode, Readout will display “- - - -“
4. Cook / Hold settings have been programmed, unit is ready to use.

## PROGRAM SEQUENCE

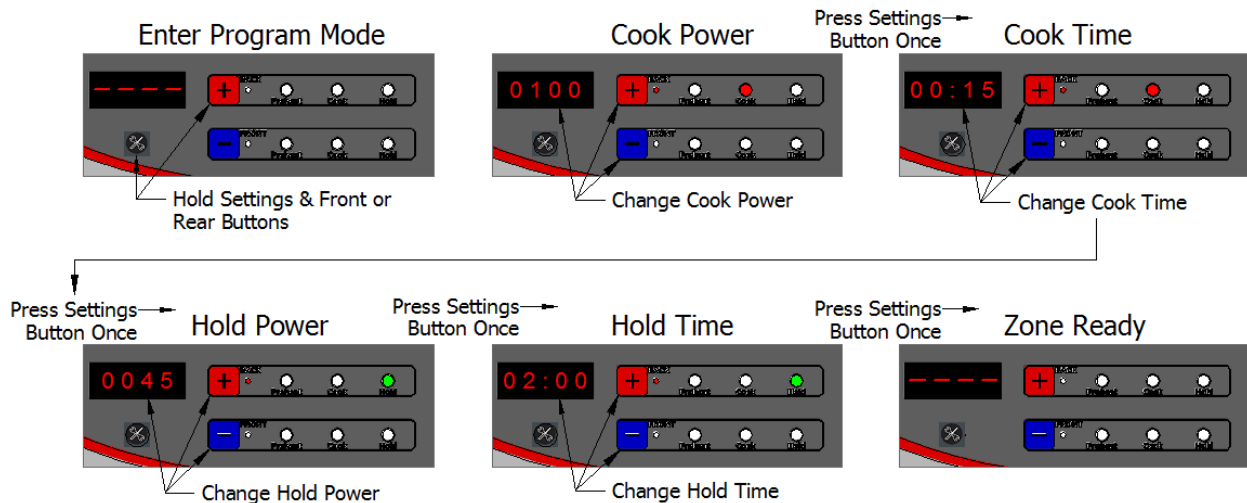

## FACTORY SETTINGS

Preheat Time	10 min
Preheat Power	100%

Cook Time	15 min
Cook Power	100%

Hold Time	4 hrs
Hold Power	43%

These settings were based on cooking standard size 8-to-1 Franks and Taquito type product. These settings will heat this type of product to 160-170°F and hold at 145-155°F. For larger product, or different temperature requirements, the Cook & Hold Time/Power Settings will need to be adjusted.

# OPERATION

## OVERVIEW:

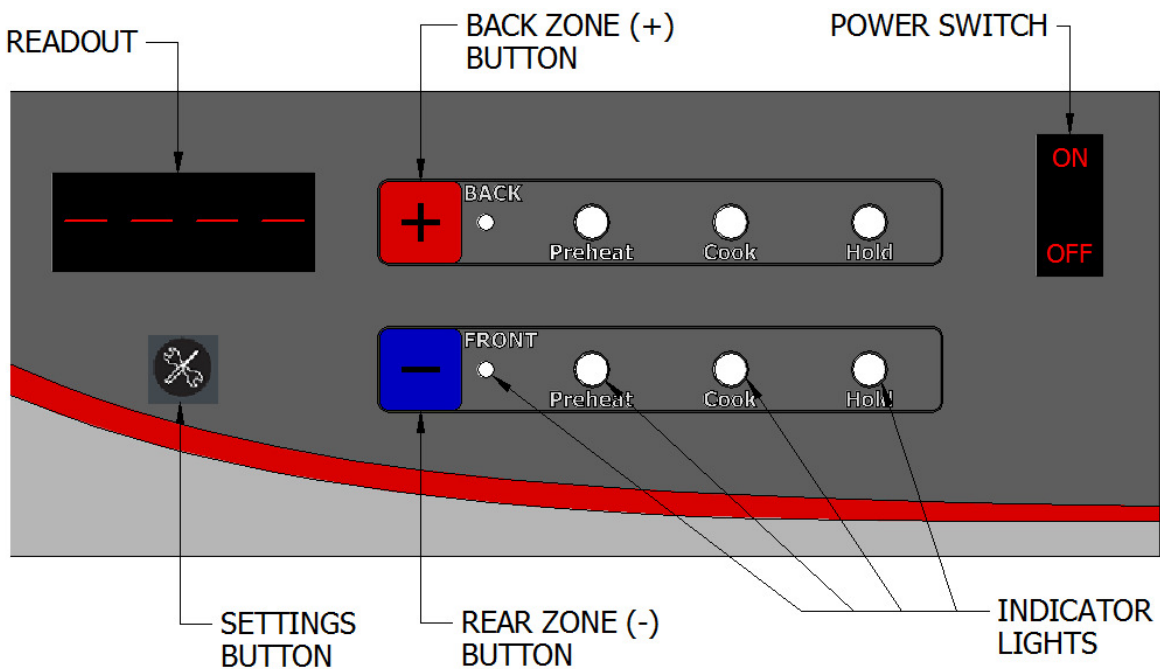

1. The control interface consists of a Power Switch, Back and Front Zone Buttons, a Settings Button, Digital Readout and LED Indicator Lights.
2. To power on the unit, turn the Power Switch to the “ON” position
3. The control will sound an alarm, and the Readout will flash.
4. When the Readout displays “- - - -“ the unit is ready to use.

## COOK CYCLE:

1. To begin using the unit, place your product on the roller grill.
2. Press the Back or Front Zone Buttons (or both to use both zones simultaneously).
3. The appropriate Indicators will light and the Readout will display Preheat Time.
  - a. NOTE: Preheat time is included in the cook cycle, it is not necessary to let unit preheat before placing product on the grill.
4. After Preheat Time is up, unit will automatically cycle to “Cook” mode.
5. The appropriate Indicators will light and the Readout will display Cook Time.
6. After the Cook Time is up, product is ready to serve and the unit will automatically cycle to “Hold” mode. While in hold mode the Readout will display the temperature of the product. When the Hold indicator begins flashing, the Hold time is up and product has passed its recommended holding time.

7. If both zones are on at the same time, the display will cycle between each zone. Press the appropriate zone button to see its display immediately.
8. (See next page for visual operation)

- Turn power switch to "ON" position.
- Readout will display "- - - -"

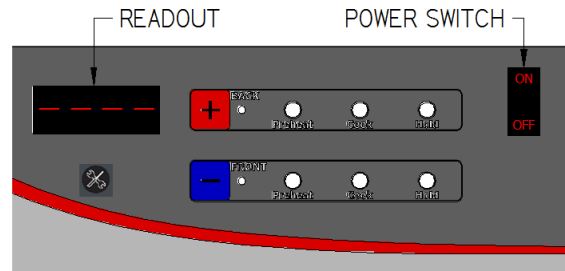

- Press BACK (+) Button once.
- "BACK" and "Preheat" Indicator lights turn on.
- Readout will display Preheat Time.

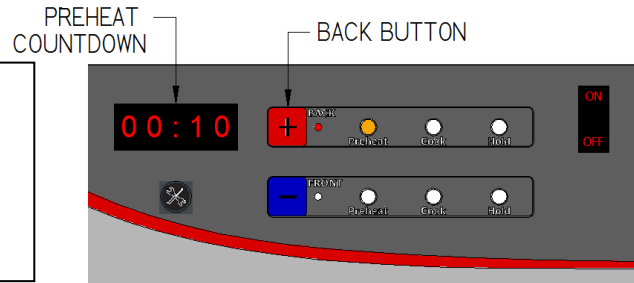

- Unit automatically enters "Cook" when Preheat countdown ends.
- "Cook" Indicator lights turn on.
- Readout will display Cook Time.

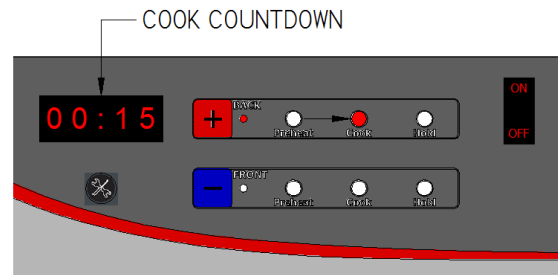

- Unit automatically enters "Hold" when Cook countdown ends
- "Hold" indicator lights turn on
- Readout will display Hold Temperature
- Hold indicator will flash when hold time is up

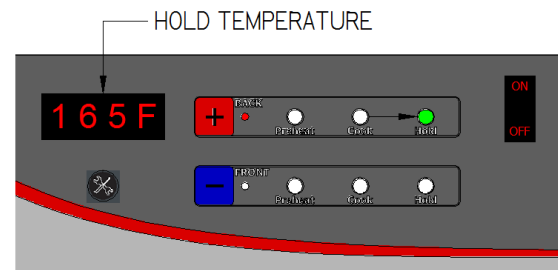

- Press and Hold BACK (+) Button to cycle between modes

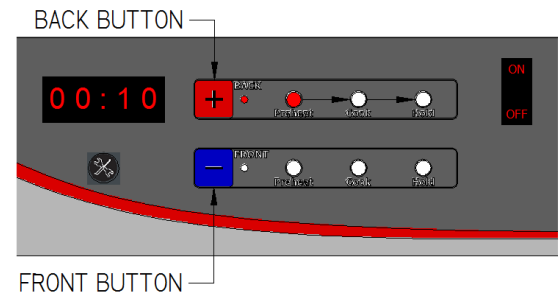

- NOTE:**
- FRONT (-) Button operation identical to Back. Readout will switch between Front and Back if both are on at the same time.

# PARTS LISTS & EXPLODED VIEWS

## HR-31 & 50 (EXPLODED VIEW)

120V	Model	208/240
(M)	HR-50	(CC)
(N)	HRS-50	(DD)
(O)	HR-50S	(EE)
(P)	HRS-50S	(FF)
(GG)	HR-50SR	
(HH)	HRS-50SR	(JJ)

120V	Model	208/240
(M)	HR-31	(CC)
(N)	HRS-31	(DD)
(O)	HR-31S	(EE)
(P)	HRS-31S	(FF)
(GG)	HR-31SR	
(HH)	HRS-31SR	(JJ)

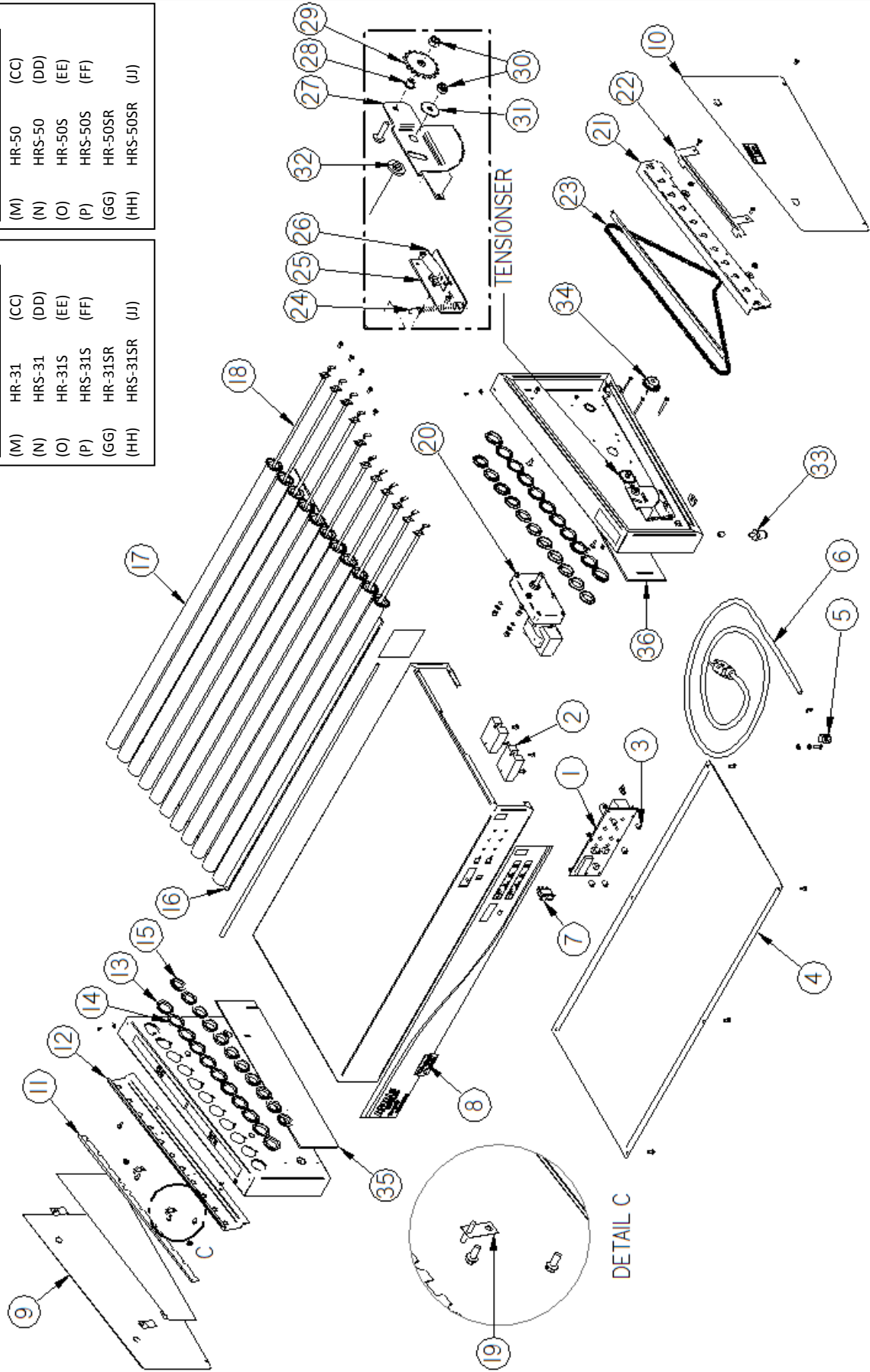



WIRE DIAGRAM - HRDi-31 / -50 (120V)

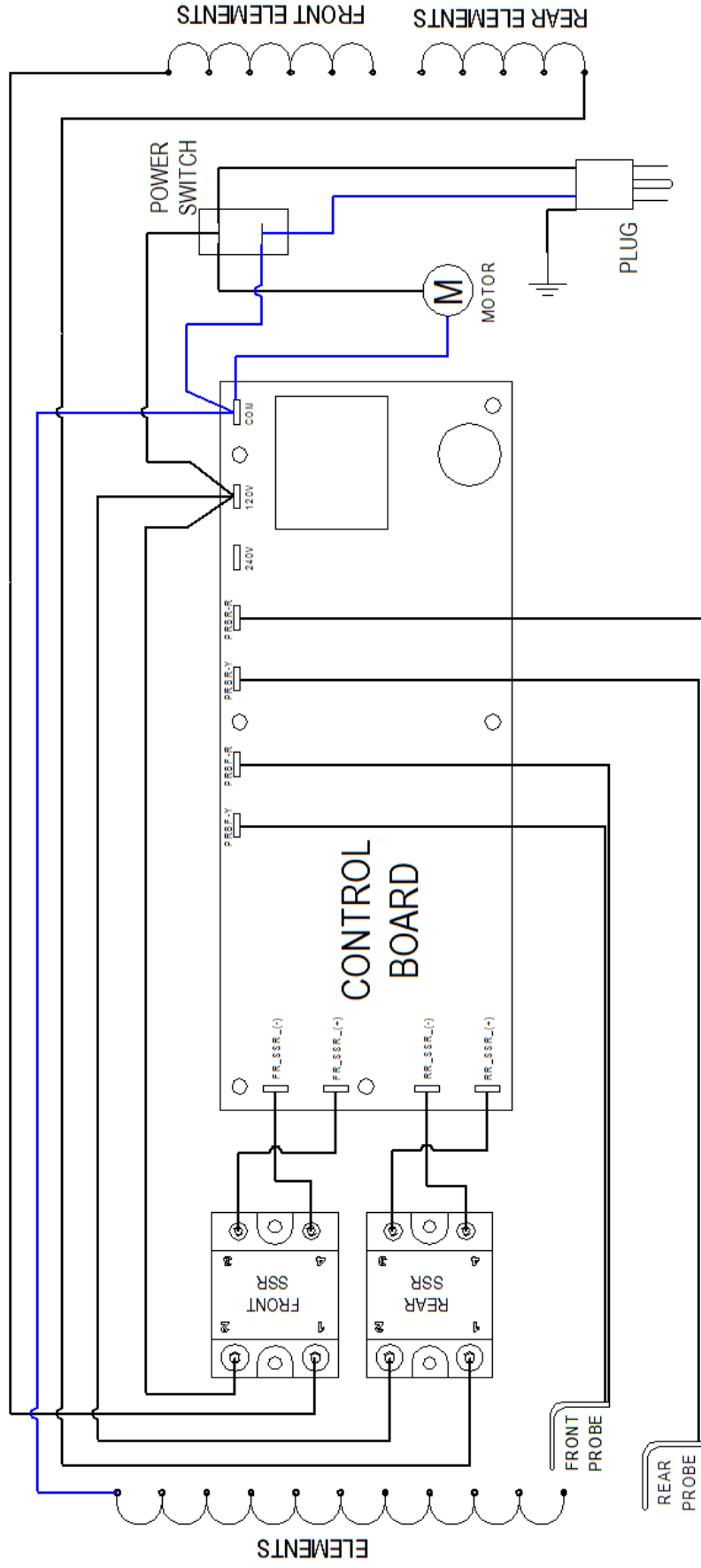

# WIRE DIAGRAM-HRDi-85BW (240V)

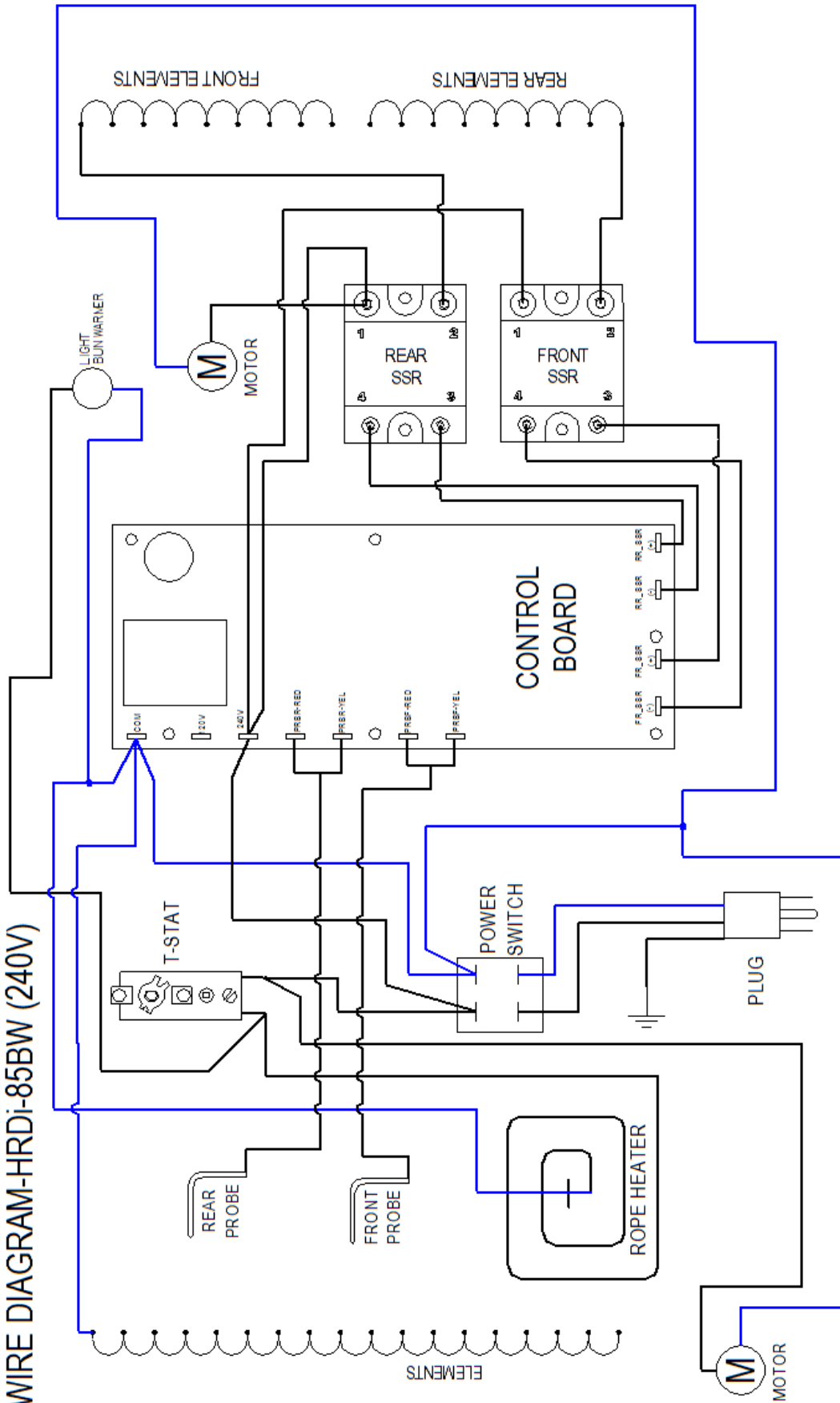

## APW WYOTT EQUIPMENT LIMITED WARRANTY

APW Wyott Foodservice Equipment Company warrants its equipment against defects in materials and workmanship, subject to the following conditions:

This warranty applies to the original owner only and is not assignable.

Should any product fail to function in its intended manner under normal use within the limits defined in this warranty, at the option of APW Wyott such product will be repaired or replaced by APW Wyott or its Authorized Service Agency. APW Wyott will only be responsible for charges incurred or service performed by its Authorized Service Agencies. The use of other than APW Wyott Authorized Service Agencies will void this warranty and APW Wyott will not be responsible for such work or any charges associated with same. The closest APW Wyott Authorized Service Agent must be used.

This warranty covers products shipped into the 48 contiguous United States, Hawaii, metropolitan areas of Alaska and Canada. There will be no labor coverage for equipment located on any island not connected by roadway to the mainland.

Warranty coverage on products used outside the 48 contiguous United States, Hawaii, and metropolitan areas of Alaska and Canada may vary. Contact the international APW Wyott distributor, dealer, or service agency for details.

### Time Period

One year for parts and one year for labor, effective from the date of purchase by the original owner. The Authorized Service Agency may, at their option, require proof of purchase. Parts replaced under this warranty are warranted for the un-expired portion of the original product warranty only.

### Exceptions

- \***Gas/Electric Cookline:** Models GCB, GCRB, GF, GGM, GGT, CHP-H, EF, EG, EHP. Three (3) Year Warranty on all component parts, except switches and thermostats. (2 additional years on parts only. No labor on second or third year.)
- \***Broiler Briquettes, Rock Grates, Cooking Grates, Burner Shields, Fireboxes:** 90 Day Material Only. No Labor.
- \***Heat Strips:** Models FD, FDL, FDD, FDDL. Two (2) Year Warranty on element only. No labor second year.
- \***Glass Windows, Doors, Seals, Rubber Seals, Light Bulbs:** 90 Day Material Only. No Labor.

In all cases, parts covered by extended warranty will be shipped FOB the factory after the first year.

### Portable Carry In Products

Equipment weighing over 70 pounds or permanently installed will be serviced on-site as per the terms of this warranty. Equipment weighing 70 pounds or under, and which is not permanently installed, i.e. with cord and plug, is considered portable and is subject to the following warranty handling limitations. If portable equipment fails to operate in its intended manner on the first day of connection, or use, at APW Wyott's option or its Authorized Service Agency, it will be serviced on site or replaced.

From day two through the conclusion of this warranty period, portable units must be taken to or sent prepaid to the APW Wyott Authorized Service Agency for in-warranty repairs. No mileage or travel charges are allowed on portable units after the first day of use. If the customer wants on-site service, they may receive same by paying the travel and mileage charges. Exceptions to this rule: (1) countertop warmers and cookers, which are covered under the Enhanced Warranty Program, and (2) toasters or rollergrills which have in store service.

### Exclusions

The following conditions are not covered by warranty:

- \*Equipment failure relating to improper installation, improper utility connection or supply and problems due to ventilation.
- \*Equipment that has not been properly maintained, calibration of controls, adjustments, damage from improper cleaning and water damage to controls.
- \*Equipment that has not been used in an appropriate manner, or has been subject to misuse or misapplication, neglect, abuse, accident, alteration, negligence, damage during transit, delivery or installation, fire, flood, riot or act of god.
- \*Equipment that has the model number or serial number removed or altered.

If the equipment has been changed, altered, modified or repaired by other than an Authorized Service Agency during or after the warranty period, then the manufacturer shall not be liable for any damages to any person or to any property, which may result from use of the equipment thereafter.

This warranty does not cover services performed at overtime or premium labor rates. Should service be required at times which normally involve overtime or premium labor rates, the owner shall be charged for the difference between normal service rates and such premium rates. APW Wyott does not assume any liability for extended delays in replacing or repairing any items beyond its control.

In all cases, the use of other than APW Wyott Authorized OEM Replacement Parts will void this warranty.

This equipment is intended for commercial use only. Warranty is void if equipment is installed in other than commercial application.

### Water Quality Requirements

Water supply intended for a unit that has in excess of 3.0 grains of hardness per gallon (GPG) must be treated or softened before being used. Water containing over 3.0 GPG will decrease the efficiency and reduce the operation life of the unit.

**Note: Product failure caused by liming or sediment buildup is not covered under warranty.**

**"THE FOREGOING WARRANTY IS IN LIEU OF ANY AND ALL OTHER WARRANTIES EXPRESSED OR IMPLIED INCLUDING ANY IMPLIED WARRANTY OF MERCHANTABILITY OR FITNESS FOR PARTICULAR PURPOSES AND CONSTITUTES THE ENTIRE LIABILITY OF APW WYOTT. IN NO EVENT DOES THE LIMITED WARRANTY EXTEND BEYOND THE TERMS STATED HEREIN."**

9/05