

OWNERS RESPONSIBILITY

NOTE:

THE PARTS AND EQUIPMENT DESCRIBED IN THIS MANUAL MAY BE COVERED BY ONE OR MORE U.S. AND FOREIGN PENDING PATENTS.



TO MAINTAIN MACHINE AND USER SAFETY, THE RESPONSIBILITY OF THE OWNER IS TO READ AND FOLLOW THESE INSTRUCTIONS AND TO ENSURE THAT ALL OPERATORS UNDERSTAND AND FOLLOW THESE AND OTHER SAFETY INSTRUCTIONS IN THIS MANUAL.

- FOLLOW ALL INSTALLATION INSTRUCTIONS.
- MAKE SURE INSTALLATION CONFORMS TO ALL APPLICABLE LOCAL, STATE, AND FEDERAL CODES, RULES AND REGULATIONS SUCH AS STATE AND FEDERAL OSHA REGULATIONS AND ELECTRICAL CODES.
- CAREFULLY CHECK THE UNIT FOR CORRECT INITIAL FUNCTION.
- READ AND FOLLOW THE SAFETY INSTRUCTIONS. KEEP THEM READILY AVAILABLE FOR MACHINE OPERATORS.
- MAKE CERTAIN ALL OPERATORS ARE PROPERLY TRAINED, KNOW HOW TO SAFELY AND CORRECTLY OPERATE THE UNIT AND ARE PROPERLY SUPERVISED.
- ALLOW UNIT OPERATION ONLY WITH ALL PARTS INCLUDING SAFETY EQUIPMENT, IN PLACE AND OPERATING SAFELY.
- CAREFULLY INSPECT THE UNIT ON A REGULAR BASIS AND PERFORM ALL MAINTENANCE AS REQUIRED.
- SERVICE AND MAINTAIN THE UNIT ONLY WITH AUTHORIZED OR APPROVED REPLACEMENT PARTS.
- KEEP ALL INSTRUCTIONS PERMANENTLY WITH THE UNIT ALONG WITH ALL DECALS AND WARNING LABELS ON THE UNIT CLEAN AND VISIBLE.

TABLE OF CONTENTS

CONTENTS	PAGE
COVER	i
OWNERS RESPONSIBILITIES	ii
TABLE OF CONTENTS	TOC
INTRODUCTION & SPECIFICATIONS & INSTALLATION	2
SAFETY SIGNAL WORDS	3
LOCATION OF WARNING LABELS & LOCATIONS	4
REPRODUCTION OF WARNING LABELS	5
SAFETY RULES	6
OPERATING INSTRUCTIONS	7-8
CLEANING PROCEDURES	9-12
GUIDE TO MAINTENANCE	13-14
BLANK PAGE	15
HOPPER COVER (STANDARD)	16-17
HOPPER COVER (EXTENDED)	18-19
DIVIDER SLIDE GUARD	20
BLANK PAGE	21
CABINET ASSEMBLY	22-23
CYLINDER AND DRIVE ASSEMBLY	24-26
BLANK PAGE	27
PISTON AND CONNECTING ROD ASSEMBLY	28-29
MEASURING CUP AND DIVIDER SLIDE ASSEMBLY	30-31
SMALL CONVEYOR & DRIVE ASSEMBLY	32-32
CONVEYOR ASSEMBLY	34-35
PRESSURE PLATE & MOUNTING FRAME	36
DOUGH CENTERING EXTENSION ARM & SECOND STAGE DIVIDER	37
ELECTRICAL SYSTEM	38-40
OILING SYSTEM	41
TROUBLE SHOOTING	42
ELECTRICAL SCHEMATICS	43-47
PARTS ORDERING INSTRUCTIONS	48
NOTES	49

IMPORTANT:

A.M. MANUFACTURING Co. RESERVES THE RIGHT TO MAKE CHANGES IN DESIGN, SPECIFICATIONS OR MANUFACTURING TO IMPROVE THEIR PRODUCTS WITHOUT NOTICE AND WITHOUT OBLIGATION TO CHANGE OR IMPROVE PREVIOUSLY BUILT PRODUCTS INCLUDING MANUALS AND CATALOGS.

ONLY USE FACTORY SUPPLIED REPLACEMENT PARTS TO MAINTAIN MACHINE SAFETY, PERFORMANCE AND SANITARY CONDITIONS. USE OF NON-APPROVED PARTS MAY VOID MANUFACTURERS WARRANTY.

KNOW YOUR UNIT. COMPARE DIAGRAMS IN THIS MANUAL WITH THE UNIT BEFORE STARTING SERVICE, TO OBTAIN MAXIMUM SAFETY AND PERFORMANCE.

TO ORDER REPLACEMENT PARTS:
TURN TO PAGE 48 OF THIS MANUAL.



WARNING:

THIS MANUAL CONTAINS CRITICAL SAFETY INSTRUCTIONS. READ AND FOLLOW THEM CAREFULLY. FAILURE TO FOLLOW WARNING AND INSTRUCTIONS MAY LEAD TO SERIOUS PERSONAL INJURY. THE OWNER IS RESPONSIBLE FOR MAINTAINING THE UNIT, ITS INSTRUCTIONS AND DECALS FOR OPERATION REFERENCE. FOR ADDITIONAL COPIES CONTACT A.M. MANUFACTURING: (800)342-6744.

OPERATIONS AND SAFETY MANUAL

INCLUDING PARTS CATALOG

**READ AND FAMILIARIZE YOURSELF WITH THIS MANUAL BEFORE OPERATING THIS MACHINE
FOLLOW INSTRUCTIONS DURING USE**

INTRODUCTION

THE ATWOOD MULTI DOUGH DIVIDER IS DESIGNED TO ACCURATELY DIVIDE DOUGH IN THE 1 TO 3oz RANGE WHERE PRODUCTION REQUIREMENTS CALL FOR 6,000 TO 10,000 DOUGH PIECES PER HOUR UTILIZING "THE FAMOUS SCALE-O-MATIC" DOUGH DIVIDER. THE S502 CAN ACCURATELY SCALE FROM 1 oz. TO $32 \pm \frac{1}{4}$ oz WITH THE PROPER ATTACHMENTS. A LARGER PIECE IS DIVIDED THEN CUT INTO 3, 4 OR 5 EQUAL PIECES. THIS UNIT IS IDEAL FOR DIVIDING A WIDE VARIETY OF PRODUCTS ESPECIALLY TORTILLAS AND PITA BREAD. NEW AND CURRENT EMPLOYEES CAN BE TAUGHT TO OPERATE THIS MACHINE EFFICIENTLY AND SAFELY IN A SHORT PERIOD OF TIME. STUDY THIS OPERATIONS AND SAFETY MANUAL FOR FULL BENEFITS.....



CAUTION:

ALL OPERATORS MUST BE FULLY TRAINED AND INSTRUCTED IN SAFETY PROCEDURES BEFORE BEGINNING PRODUCTION.

SPECIFICATIONS

HOPPER CAPACITY	100 lbs.
EXTENDED HOPPER (140 lbs. CAPACITY)	2000 PIECES PER HOUR
PRODUCTION RATE	58"
HEIGHT	82"
LENGTH	26"
WIDTH	1000 lbs.
SHIPPING WEIGHT	3 PHASE, 2 H.P. MOTOR (STANDARD)
DIVIDER	SINGLE PHASE, 1½ H.P. MOTOR (OPTIONAL)
	DOUBLE SHEAVE BELT DRIVE
	1 PHASE, ¾ H.P. MOTOR
	1 PHASE, 1/16 H.P. MOTOR
CONVEYOR MOTOR	
SMALL CONVEYOR MOTOR	
RECIPROCAL MOTION	
MECHANICAL DIVIDER	
AUTOMATIC SPRING PRESSURE, SELF ADJUSTABLE	
EXTRA DIVIDER CUPS AVAILABLE AS OPTIONAL EQUIPMENT.	
NO. 2 DIVIDING CUP 2 TO 4 oz.	
NO. 3 DIVIDING CUP 4 TO 10 oz	
VOLTAGES:	
3 PHASE, 208 - 230 VOLTS VARIABLE SPEED (STANDARD)	
3 PHASE, 380 – 480 VOLTS VARIABLE SPEED (OPTIONAL)	
SINGLE PHASE, 208/220 VOLT (OPTIONAL)	
	OPTIONAL EQUIPMENT
	3 CUTTER (2 TO 3 oz.)
	4 CUTTER (1-1/4 TO 2 oz.)
	5 CUTTER (¾ TO 1-1/4 oz.)

INSTALLATION INSTRUCTIONS

LOCATION:

SELECT LOCATION CAREFULLY. THE AREA SHOULD PROVIDE THE OPERATOR WITH ENOUGH SPACE TO USE THE EQUIPMENT IN A SAFE MANNER. THE FLOOR AREA SELECTED SHOULD BE EASY TO CLEAN AND SHOULD BE FREE OF OIL, GREASE, ETC. AVOID AREAS WHERE BYSTANDERS AND CUSTOMERS MAY BE PRESENT.



CAUTION:

PROPER UNIT INSTALLATION IS NECESSARY FOR SAFE AND EFFICIENT OPERATION. PROPER INSTALLATION ALSO HELPS PROTECT THE UNIT FROM DAMAGE AND MAKES SERVICE EASIER.

SAFETY

THIS MACHINE IS DESIGNED TO PROVIDE FOR SAFE OPERATION IF NORMAL OPERATING PROCEDURES AND SAFETY MESSAGES LOCATED ON THE MACHINE AND IN THIS MANUAL ARE FOLLOWED.



THIS IS A SAFETY ALERT SYMBOL. YOU WILL FIND IT ON VARIOUS SAFETY LABELS ON THE MACHINE AND IT WILL ALSO APPEAR IN THIS MANUAL WHEREVER SAFETY MESSAGES ARE GIVEN.

GET FAMILIAR WITH SIGNAL WORDS:

CAUTION, WARNING & DANGER

CAUTION:

INDICATES A POTENTIALLY HAZARDOUS SITUATION WHICH, IF NOT AVOIDED, MAY RESULT IN MINOR OR MODERATE INJURY. IT MAY ALSO BE USED TO ALERT AGAINST UNSAFE PRACTICES.

WARNING:

INDICATES A POTENTIALLY HAZARDOUS SITUATION WHICH, IF NOT AVOIDED, COULD RESULT IN DEATH OR SERIOUS INJURY.

DANGER:

INDICATES AN IMMINENTLY HAZARDOUS SITUATION WHICH, IF NOT AVOIDED, WILL RESULT IN DEATH OR SERIOUS INJURY. THIS SIGNAL WORD IS TO BE LIMITED TO THE MOST EXTREME SITUATIONS.

NOTE:

A NOTE PROVIDES KEY INFORMATION TO MAKE PROCEDURES EASIER AND CLEARER.

TYPICAL WARNING LOCATIONS

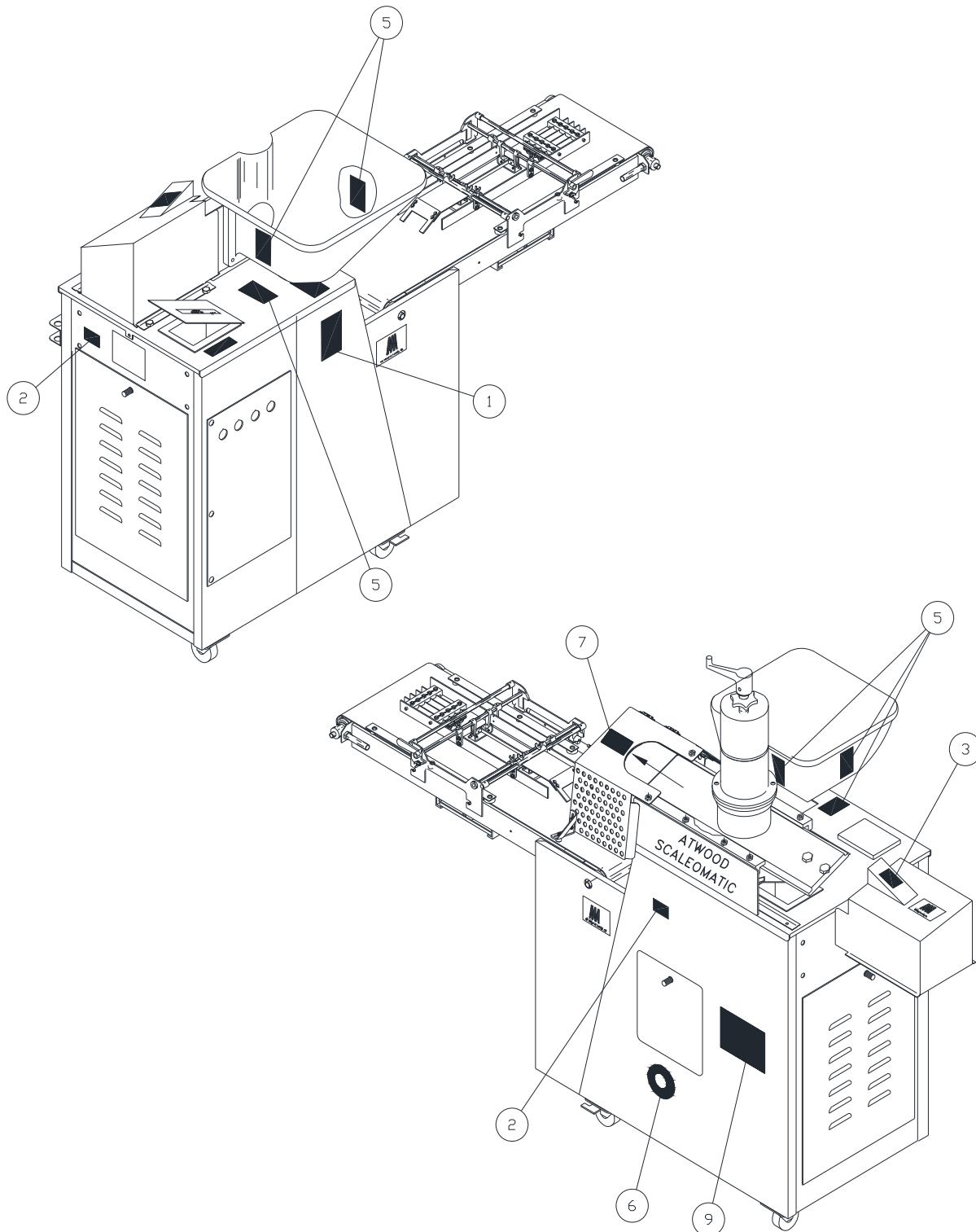

WARNING LABELS

TYPICALLY FOUND ON THE SCALE-O-MATIC MODEL: S502

PART NO. AM MFG. #21

IMPORTANT SAFETY INFORMATION ©1992 AM. MFG. #21

- DO NOT OPERATE THIS MACHINE BEFORE YOU HAVE READ AND UNDERSTAND THE OPERATIONS AND SAFETY MANUAL.
- NEVER LEAVE THIS MACHINE RUNNING UNATTENDED.
- NEVER OPERATE THIS MACHINE IF SAFETY GUARDS ARE NOT IN PLACE.
- NEVER REMOVE ANY SAFETY GUARDS AND NEVER MAKE ANY OTHER SAFETY EQUIPMENT INOPERATIVE.
- NEVER OPERATE THIS MACHINE IF YOU HAVE NOT BEEN TRAINED.
- NEVER OPERATE THIS MACHINE IF YOU ARE TIRED, ILL, OR IF YOU ARE ON MEDICATION THAT MAKES YOU TIRED, OR IF YOU ARE UNDER THE INFLUENCE OF ALCOHOL OR DRUGS.
- WEAR TIGHT FITTING CLOTHES AND MAKE SURE THAT LONG HAIR AND JEWELRY OR OTHER LOOSE PERSONAL ITEMS DO NOT GET CAUGHT IN THE MACHINE.
- MAKE SURE YOU CAN EASILY REACH THE CONTROLS.
- ALWAYS DISCONNECT THE MAIN ELECTRICAL POWER SOURCE BEFORE YOU CLEAN, MAINTAIN, OR SERVICE THIS MACHINE.
- IF YOU HAVE ANY QUESTIONS ABOUT SAFETY, TALK TO YOUR SUPERVISOR OR CALL.

A.M. MANUFACTURING
 TOLL FREE (800) 342-6744

① MAIN FRAME CABINET (RIGHT SIDE OF CONTROL PANEL)

PART NO. AM MFG. #10



⚠ DANGER

HAZARDOUS VOLTAGE, WILL SHOCK, BURN, OR CAUSE DEATH

DISCONNECT ALL ELECTRICAL POWER BEFORE REMOVING PROTECTIVE SHIELDS OR TOUCHING ELECTRICAL EQUIPMENT WHILE SERVING OR CLEANING THIS MACHINE.....

© 1992 AM. MFG. #10

② REAR PANEL OF DIVIDER CABINET
 CABINET (PISTON ENTRY SIDE)
 UNDER OIL RESERVOIR

PART NO. AM MFG. #11

⚠ WARNING

ALL GUARDS AND SAFETY SHIELDS MUST BE IN PLACE BEFORE STARTING MACHINE. NEVER OPERATE THIS MACHINE WITHOUT SAFETY SHIELDS IN PLACE. DO NOT CHANGE THIS MACHINE IN ANY WAY TO INTERFERE WITH OR ELIMINATE THESE ESSENTIAL SAFETY FEATURES.

© 1992 AM. MFG. #11

③ ROCKER ARM COVER
 IDLER PULLEY GUARD
 CHAIN GUARD

PART NO. AM MFG. #24



⚠ WARNING

EXPOSED CHAIN AND GEARS. CAN CAUSE SERIOUS INJURIES.

STAY AWAY WHEN CHAIN IS MOVING.

© 1992 AM. MFG. #24

④ FRONT SIDE HINGED COVER
 INSIDE FRONT SIDE WALL OF ROUNDER CABINET

PART NO. AM MFG. #27

DANGER

IF YOU PUT YOUR FINGERS IN THE DOUGH HOPPERS BOTTOM OPEN CHAMBER THAT ENCASES THE CUTTING PISTON WHEN SAID MACHINE IS ON AND OPERATING, THERE IS THE POSSIBILITY THAT YOUR FINGER COULD BE SEVERED AS A RESULT OF THIS ELECTIVE ACTION.



† about guards or guarding call (788) 841-9999

⑤ ALL (4) SIDES OF DOUGH HOPPER
 TOP COVER

PART NO. TAG 2025



⑥ LEFT SIDE OF CABINET

PART NO. AM MFG. #11

⚠ WARNING

ALL GUARDS AND SAFETY SHIELDS MUST BE IN PLACE BEFORE STARTING MACHINE. NEVER OPERATE THIS MACHINE WITHOUT SAFETY SHIELDS IN PLACE. DO NOT CHANGE THIS MACHINE IN ANY WAY TO INTERFERE WITH OR ELIMINATE THESE ESSENTIAL SAFETY FEATURES.

⚠ AVERTISSEMENT

TOUS LES ECRANS DE SECURITE ET DISPOSITIFS DE PROTECTION DOIVENT ETRE EN PLACE AU DEMARRAGE DE LA MACHINE. NE JAMAIS FAIRE FONCTIONNER CETTE MACHINE SI LES ECRANS DE SECURITE NE SONT PAS EN PLACE. NE PAS MODIFIER CETTE MACHINE DE FACON A ENTRAVER OU ELIMINER CES DISPOSITIFS DE SECURITE ESSENTIELS.

©2009 A.M. MFG. #11

⑦ TOP OF DIVIDER SLIDE GUARD

PART NO. AM MFG. #1605F

⚠ CAUTION

PINCH POINT PRESENT WHEN INSERTING ROUNDER SCREW INTO MACHINE!

KEEP FINGERS CLEAR FROM EDGE OF ROUNDER SCREW NEAR ROUNDER DRUM WHEN INSERTING AND REMOVING ROUNDER SCREWS.

⚠ ATTENTION

POINT DE PINCEMENT PRESENT QUAND LA VIS RONDE EST INSEREES DANS LA MACHINE!

GARDER LES DOIGTS A L'ECART DU BORD DE LA VIS RONDE PRES DU TAMBOUR ROND AU MOMENT D'INSERER OU D'ENLEVER LA VIS RONDE.

© 2009 AM. MFG. #1605F

⑧ TOP OF ROUNDER COVER BACK SIDE

PART NO. AM MFG. #203S

PISTON REMOVAL PROCEDURE

"ALWAYS TURN THE CRANK COUNTER CLOCKWISE"

1. CRANK THE PISTON TO POSITION #1: REMOVE THE MEASURING CUP AND SLIDE.
2. REMOVE PIN "A" FROM ITS HOLE AND PLACE IT IN THE BOLT TRAY PROVIDED ON SIDE OF MACHINE.
3. CRANK THE PISTON TO POSITION #2 WITH THE SPRING ASSEMBLY ALL THE WAY AT THE BOTTOM OF ITS STROKE.
4. PULL PIN "B" OUT OF ITS HOLE AND PLACE IT IN HOLE "C".
5. CRANK THE PISTON TO POSITION #3; THE PISTON HAS BEEN PUSHED OUT OF THE TOP OF THE CYLINDER.

©2009 A.M. MFG. #203S

⑨ LEFT SIDE OF CABINET

NOTE:

MACHINE DESIGN AND SPECIFICATIONS MAY VARY. ACTUAL LABEL DESIGN AND PLACEMENT SUBJECT TO CHANGE WITHOUT NOTICE AND MAY VARY FROM THIS ILLUSTRATION.



CAUTION:
 IF ANY SAFETY LABELS ARE MISSING, THEY **MUST BE REPLACED!** CONTACT YOUR DEALER OR A.M. MFG. FOR REPLACEMENT.

SAFETY RULES



IMPORTANT:

READ AND FOLLOW THESE SAFETY RULES. THEY ARE FOR YOUR PROTECTION AND THE PROTECTION OF THOSE WORKING WITH YOU.

- DO NOT OPERATE THIS MACHINE BEFORE YOU READ AND UNDERSTAND THE OPERATIONS AND SAFETY MANUAL.
- FOLLOW ALL INSTRUCTIONS DURING USE OF THIS MACHINE.
- LEAVE ALL GUARDS IN PLACE. INSTALL ALL GUARDS IF THEY WERE REMOVED FOR CLEANING, MAINTENANCE, REPAIR OR OTHER REASONS.
- NEVER OPERATE THE MACHINE IF YOU HAVE NOT BEEN TRAINED TO OPERATE THE MACHINE PROPERLY.
- NEVER OPERATE THE MACHINE IF YOU ARE TIRED, ILL, ON MEDICATION, OR UNDER THE INFLUENCE OF ALCOHOL OR DRUGS.
- WEAR TIGHT FITTING CLOTHES. MAKE SURE THAT LONG HAIR, JEWELRY, OR LOOSE PERSONAL ITEMS ARE SECURED SO THEY CANNOT GET CAUGHT IN THE MACHINE. THIS CAN LEAD TO SERIOUS INJURIES.
- MAKE SURE YOU CAN EASILY REACH ALL CONTROLS. IF NOT, A STABLE AND SAFE ELEVATED PLATFORM OR OTHER WORK-AID MUST BE PROVIDED.
- ALWAYS DISCONNECT THE MAIN ELECTRICAL POWER SOURCE BEFORE CLEANING, IF MAINTENANCE OR SERVICE IS PERFORMED, OR IF THE MACHINE IS OUT OF SERVICE.
- YOU SHOULD REMOVE THE BELTS FROM MACHINE PRIOR TO CLEANING THEM IF THEY ARE EASILY REMOVABLE. THIS WILL PREVENT BACTERIA FROM BUILDING UP ON THE UNDER SIDE OF THE BELT.
- NEVER LEAVE THIS MACHINE RUNNING UNATTENDED.
- GUARDS ARE INTERLOCKED; MACHINE WILL NOT OPERATE WITHOUT GUARDS IN PLACE.

IMPORTANT:

IF YOU HAVE ANY QUESTIONS ABOUT THESE SAFETY RULES, SEE YOUR SUPERVISOR OR CALL A.M. MANUFACTURING Co. TOLL FREE: (800)342-6744

OPERATING INSTRUCTIONS



WARNING:

UNIT MUST BE PROPERLY OPERATED AND MAINTAINED TO PREVENT MACHINE DAMAGE OR PERSONAL INJURY. REVIEW INSTRUCTIONS WITH ALL EMPLOYEES BEFORE USE.



CAUTION:

BEFORE BEGINNING START - UP, READ ALL INSTRUCTIONS AND FAMILIARIZE YOURSELF WITH THE LOCATIONS OF ALL CONTROLS. KNOW HOW TO SHUT DOWN THE UNIT IMMEDIATELY IN CASE OF TROUBLE. MAKE CERTAIN ALL PERSONNEL NOT INVOLVED IN THE START - UP ARE SAFELY AWAY FROM THE MACHINE BEFORE ANY SYSTEMS ARE STARTED...

I. PRELIMINARY START-UP DIVIDER

- A. REMOVE PACKING, PACKING SLIPS, DOCUMENTS AND OTHER OBSTRUCTIONS FROM HOPPER.
- B. MAKE SURE MACHINE IS ON A FLAT SURFACE.
- C. MOVE MACHINE INTO POSITION AND LOCK CASTERS.
- D. PLUG POWER CORD INTO PROPER RECEPTACLE / PROPER GROUNDING IS NECESSARY TO PREVENT ANY TYPE OF ELECTROSTATIC PHENOMENIA.
- E. PUSH DIVIDER START BUTTON.
- F. CHECK ROTATION OF DIVIDER BY LOOKING THRU THE SMALL INSPECTION DOOR. THE LARGE GEAR SHOULD BE TURNING (C.W.) CLOCK WISE.
- G. IF THE GEAR IS TURNING IN THE (C.C.W.) COUNTER CLOCK WISE DIRECTION, CONSULT A PROPERLY TRAINED ELECTRICIAN.
- H. IF ROTATION IS CORRECT, YOU ARE READY TO CONTINUE WITH THESE PROCEDURES.

II. PRELIMINARY START-UP ROUNDING CONV .

- A. MAKE SURE CONVEYOR IS SECURELY FASTENED TO CABINET
- B. INSTALL GEAR MOTOR BREATHER (OIL VENT).
- C. BE SURE CONVEYOR IS CLEAR AND NOT ABSTRACTED.
- D. CHECK ROUNDER MOTOR CORD CONNECTION TO CABINET RECEPTACLE.
- E. PUSH CONVEYOR / ROUNDER START BUTTON.
- F. CHECK CONVEYOR BELT. THE BELT SHOULD BE RUNNING FORWARD, OUT FROM MACHINE.
- G. IF THE BELT IS RUNNIN BACKWARDS TWARDS THE MACHINE, CONSULT A PROPERLY TRAINED ELECTRICIAN.
- H. SHUT OFF CONVEYOR / ROUNDER.

III. OPERATION OF DIVIDER

- A. FILL THE OIL RESERVOIR WITH LIGHTWEIGHT MINERAL OIL. BE SURE TO CLEAN ANY OIL SPILL AROUND MACHINE. THESE SURFACES BECOME SLIPPERY.
- B. WITH THE SQUIRT BOTTLE SUPPLIED, APPLY A SMALL AMOUNT OF MINERAL OIL TO THE INSIDE SIDES OF THE DOUGH HOPPER. (HOPPER SHOULD BE OILED EVERY TIME YOU PLACE NEW DOUGH IN IT.)
- C. OPEN THE VALVE LOCATED ON THE TOP GIB BAR APPROXIMATELY 1/8 OF A TURN.
- D. REMOVE BACK CABINET DOOR.
- E. OPEN THE CYLINDER VALVE APPROXIMATELY 1/8 OF A TURN. THIS VALVE IS LOCATED ON THE OIL PUMP BEHIND THE REAR DOOR.
- F. REINSTALL THE BACK CABINET DOOR.
- G. FILL THE HOPPER WITH DOUGH. BY LOADING DOUGH @ 20 lbs. PIECES. DO NOT LIFT MORE THAN 20 lbs. PIECES. THIS COULD CAUSE SERIOUS LOWER BACK INJURY.
- H. CLOSE HOPPER COVER AND PULL SPRING PIN AND SET HOPPER PADDLE ON TOP OF DOUGH.
- I. PRESS THE "CONVEYOR / ROUNDER" START BUTTON.
- J. PRESS DIVIDER START BUTTON.
- K. PRESS DIVIDER BUTTON.



CAUTION:

PISTON WILL MOVE AFTER POWER IS TURNED OFF OR DISCONNECTED.

OPERATING INSTRUCTIONS CONT.

IV. DIVIDING THE DOUGH

- A. DOUGH IS PORTIONED IN THE MEASURING CUP LOCATED ON THE DIVIDER SLIDE.
- B.  TO ADJUST THE WEIGHT, STOP THE MACHINE.
- C. LOOSEN THE LOCKING STAR KNOB (529MS-2D) CLOSEST TO THE MEASURING CUP STOP COVER AND TURN THE TOP STAR KNOB (529MS-2F-A). **NOTE: ALWAYS LOOSEN THE STAR KNOB CLOSEST TO THE MEASURING CUP STOP COVER. FAILURE TO DO SO CAN RESULT IN DAMAGE TO THE CUP.**
- D. BY TURNING THE TOP STAR KNOB IN A COUNTER CLOCKWISE MOTION, THE DOUGH WEIGHT WILL INCREASE. TURNING THE TOP STAR KNOB IN A CLOCKWISE MOTION DECREASES THE DOUGH WEIGHT.
- E. FIND YOUR DESIRED DOUGH WEIGHT BY WEIGHING THE DOUGH PIECE.
- F. ONCE YOU HAVE ACHIEVED THIS, TIGHTEN DOWN THE LOCKING STAR KNOB (529MS-2D) TO THE TOP OF THE MEASURING CUP TO KEEP SCALING ACCURATE.

V. SECOND STAGE DIVIDER

AFTER THE DOUGH HAS BEEN DIVIDED, IT WILL TRANSFER FROM THE SMALL DROP CONVEYOR TO THE LARGE CONVEYOR AND CONTINUE THRU THE SECOND STAGE DIVIDER. IT IS THEN DIVIDED AGAIN AUTOMATICALLY INTO 2, 3, 4 OR 5 EQUAL PIECES, ACCORDING TO THE SIZE REQUIRED.

- A. THE SECOND STAGE DIVIDER HAS BEEN PRE-ADJUSTED AT THE FACTORY. THE PRESSURE PLATE HAS BEEN SECURED FOR SHIPPING PURPOSES. VERIFY ADJUSTMENT PRIOR TO USE.
- B. TO OPERATE THE SECOND STAGE DIVIDER YOU MUST FIRST BE CERTAIN IT IS DISCONNECTED FROM THE POWER SOURCE. NEXT RAISE THE PRESSURE PLATE APPROXIMATELY 1-1/2" FROM THE CONVEYOR BELT. THIS IS ACCOMPLISHED BY LOOSENING THE WING BOLT (PART #: F0604WB) AND THEN RAISING THE HANDLE (PART #: MPP15) TO THE DESIRED HEIGHT.
- C. LOCK THE PRESSURE PLATE IN PLACE BY TIGHTENING THE WING BOLTS (PART #: F0604WB). RECONNECT POWER SOURCE AND PUSH THE CONVEYOR / ROUNDER START BUTTON.
- D. PUSH THE DIVIDER START BUTTON AFTER CHECKING TO BE SURE THE CONVEYOR ARE CLEAR.
- E. AFTER DOUGH IS DIVIDED, DOUGH PIECES SHOULD BE SPREAD INTO A STRAIGHT EVEN SHAPE WHEN IT COMES OUT OF THE PRESSURE PLATE. AN INCONSISTANT SHAPE WILL CAUSE INCONSISTENT PIECES (WEIGHTS) OUT OF THE SECOND STAGE DIVIDER.

NOTE: TOO MUCH PRESSURE ON THE DOUGH PIECE GOING THRU THE PRESSURE PLATE WILL CAUSE THE PIECE TO ARCH FORWARD IN THE CENTER. THIS CAN CAUSE THE MIDDLE PIECES FROM THE SECOND STAGE DIVIDER TO BE HEAVIER THAN THE END PIECES. TOO LITTLE PRESSURE WILL NOT GIVE AN EVEN SPREAD CAUSING DOUGH PIECES TO BE HEAVY ON ONE SIDE.

- F.  IF DESIRED RESULTS ARE NOT ACHIEVED, STOP MACHINE
- G. REPEAT STEPS 2 THRU 5.
- H. AFTER ACHIEVING DESIRED RESULTS, MAKE A NOTE OF THE SETTING OF THE PRESSURE PLATE BY USING THE NUMBER LOCATED ABOVE THE ADJUSTING HANDLE.

DIVIDER CLEANING PROCEDURES

**THESE PROCEDURES ARE VERY IMPORTANT TO MAINTAIN
PRODUCT QUALITY AND MACHINE PERFORMANCE.**

ALL A.M. MANUFACTURING MACHINES ARE TESTED WITH DOUGH DURING THE IN-HOUSE RUN-IN AND QUALITY AUDIT PROCEDURE. ALTHOUGH THE MACHINE HAS BEEN CLEANED, SOME EVIDENCE OF DOUGH ON AND IN THE MACHINE MAY BE DETECTED. THIS IS NORMAL. ALL PARTS IN CONTACT WITH DOUGH SHOULD BE WASHED THOROUGHLY AFTER USE, USING A MILD SOAP AND WATER SOLUTION. DISASSEMBLY OF THIS MACHINE FOR CLEANING IS OUTLINED BELOW AND ILLUSTRATED FOR YOUR CONVENIENCE. INSTRUCTIONS IN THIS MANUAL INDICATE THE NEED FOR REGULAR INSPECTIONS & CLEANING TO PREVENT INFESTATION.

I. DIVIDER



- A. **DANGER: SHUT OFF ALL ELECTRICAL POWER**
- B. REMOVE COVER OVER DRIVE END OF SLIDE
- C. LOOSEN FOUR (4) SOCKET SCREWS AT TOP OF CUP; TWIST AND REMOVE CUP.
- D. REMOVE INSERT. (IF APPLICABLE) (MEASURING CUPS 1,2 & 3)
- E. REMOVE TWO (2) END BOLTS AT DRIVE END OF SLIDE.
- F. LOOSEN EIGHT (8) HEX HEAD NUTS AT TOP OF GIB BARS AND GIB DIVIDER SLIDE GUARD, GIB BARS AND SLIDE.
- G. REMOVE PISTON BY – INSERTING CRANK IN PINION GEAR ON SIDE OF CABINET THEN:
 1. LOOSEN TWO (2) SCREWS ON THE SIDE OF SPRING ASSEMBLY AND SLIDE TO RIGHT.
 2. REMOVE UPPER PIN AND CRANK ASSEMBLY THROUGH ONE (1) ROTATION, THUS SEPARATING THE SHAFT.
 3. PUT LOWER PIN IN UPPER HOLE AND ROTATE UNIT UNTIL PISTON COMES OUT OF THE CYLINDER.
 4. REMOVE PISTON AND CLEAN.
 5. REMOVE SEAL SCRAPER RING AND “O” RING ON FACING OF CYLINDER AND CLEAN.
 6. CLEAN ALL DOUGH RESIDUE OFF OF FACING AND INNER CYLINDER. MAKE SURE YOU CLEAN OUT THE OIL HOLE. (CHECK VALVE)
- I. REPLACE PISTON BY:
 1. MAKING SURE PISTON IS IN EXTENDED POSITION w/ PIN IN UPPER HOLE.
 2. PUT PISTON IN CYLINDER – GUIDING SHAFT INTO THE SPRING LOAD ASSEMBLY.
 3. TAKE OTHER PIN AND PUT IT THROUGH SPRING LOAD ASSEMBLY AND LOWER SHAFT HOLE.
 4. ROTATE CRANK UNTIL UPPER PIN IS VISIBLE AND REMOVE.
 5. TURN CRANK UNTIL SHAFT COLLAPSES AND TWO (2) UPPER HOLES MEET, INSERT PIN AND PUSH SLIDE OVER AND TIGHTEN ALLEN SCREWS.
 6. BE SURE PISTON IS COLLAPSED BY MAKING ONE FULL ROTATION NOTING THAT PISTON DOES NOT COME ABOVE UPPER CYLINDER.
- J. PLACE SLIDE BACK ON TOP OF CYLINDER AND ATTACH CAM ARM SLIDE USING THE TWO (2) BOLTS SUPPLIED TIGHTLY.
- K. PLACE GIB BARS ON CYLINDER AND THEN PLACE DIVIDER SLIDE GUARD ON TOP OF GIB BARS AND TIGHTEN THE (8) HEX NUTS PROVIDED.
- L. REPLACE INSERT AND MEASURING CUP, RE-TIGHTEN FOUR (4) SOCKET HEAD SCREWS.
- M. REMOVE HAND CRANK AFTER ASSEMBLY.

II. SECOND STAGE DIVIDER



- A. **DANGER: SHUT OFF ALL ELECTRICAL POWER** (REMOVE CRUMB PAN (PART #: 153RC).
- B. WIPE OFF SCRAPER (PART #: 132RC)
- C. RELEASE SECOND STAGE DIVIDER UNIT BY PULLING AWAY FROM CABINET.
- D. NOW PIVOT SECOND STAGE DIVIDER UNIT UP AND AWAY FROM THE CONVEYOR.
- E. CLEAN SECOND STAGE DIVIDER UNIT AND WIPE DOWN REST OF ASSEMBLY
- F. CLEAN AND SCRAPE EXCESS DOUGH FROM BELT
- G. RE-ATTACH SECOND STAGE DIVIDER UNIT.



PRACTICE SAFETY FIRST:

ALWAYS DISCONNECT ELECTRICAL SERVICE WHEN CLEANING OR MAINTAINING THIS MACHINE, THUS AVOIDING CHANCE OF SERIOUS INJURIES. MACHINES ARE NOT DANGEROUS IF COMMON SENSE IS APPLIED AND THE INSTRUCTIONS ARE CAREFULLY FOLLOWED. THINK AND PRACTICE SAFETY FIRST.

GUIDE TO CLEANING



DANGER:
ALWAYS DISCONNECT ELECTRICAL SERVICE WHEN
CLEANING, MAINTAINING OR REPAIRING THIS MACHINE...

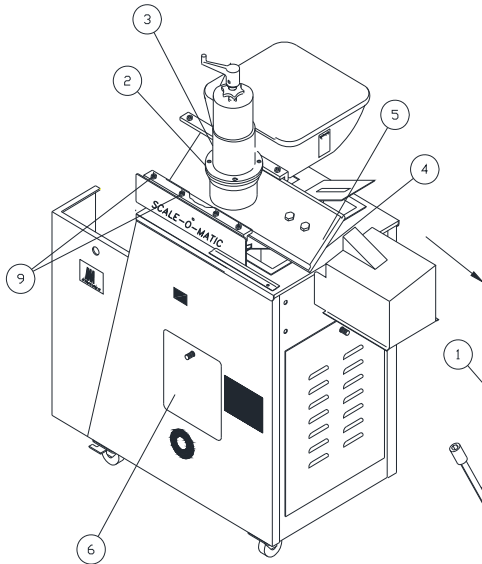

FIGURE 1

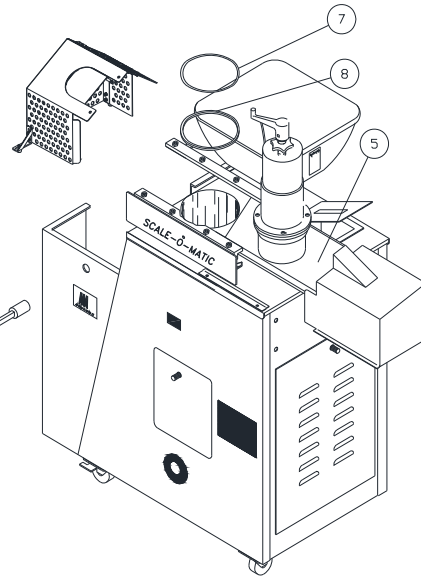

FIGURE 2

STEP 1

USING AN ALLEN WRENCH, LOOSEN SOCKET HEAD SCREWS (2) AND LIFT PULL OUT DIVIDER PLUNGER (MEASURING CUP) (3). WHEN A #2 OR #3 MEASURING CUP IS USED, THE DIVIDER CYLINDER MUST ALSO BE REMOVED FROM SLIDE FOR CLEANING.

STEP 2

LOOSEN EIGHT HEX HEAD BOLTS AT TOP OF GIB BARS. USING WRENCH (1) REMOVE TWO HEX HEAD SCREWS (4) AND PUSH DIVIDER SLIDE (5) REARWARD TO EXPOSE CYLINDER OPENING.

STEP 3

REMOVE CABINET DOOR (6).

STEP 4

WITH CYLINDER OPENING EXPOSED, REMOVE SEAL SCRAPER RING (7) AND RUBBER "O" RING (8). CLEAN ALL EXPOSED SURFACES INCLUDING "O" RING GROOVE AND DIVIDING SLIDE OF ACCUMULATED DOUGH, OIL, ETC. WIPE EXCESS DOUGH FROM TOP AND INTERIOR OF CYLINDER.

STEP 5

WIPE EXCESS DOUGH FROM INSIDE OF DOUGH HOPPER.

NOTE:

NEVER USE METAL EDGED SCRAPER FOR CLEANING ANY PART. USE OF SUCH TOOLS CAN RESULT IN DAMAGE.

SCALE - O - MATIC NAME PLATE

THIS PLATE HAS A 2-CHANNEL GROOVE THAT CATCHES EXCESS OIL AND DRAINS INTO DRIP PAN AT THE BOTTOM OF THE MACHINE. THIS PLATE SHOULD BE REMOVED BY LOOSENING AND REMOVING A SMALL ALLEN SCREW IN THE CENTER OF THE PLATE. CLEAN PLATE, AND CHECK PLASTIC DRAIN LINE TO SEE THAT IT IS CLEAN AND FREE OF ANY SEDIMENT SO OIL CAN DRAIN PROPERLY. DRIP PAN AT BOTTOM OF MACHINE SHOULD BE EMPTIED EVERY DAY.

GUIDE TO CLEANING

STEP 5

LOOSEN SOCKET SCREWS (9) ENOUGH TO SLIDE PIN LOCK BRACKET (10) EXPOSING LOCK PIN (11). REMOVE PIN (11).

STEP 6

INSERT CRANK HANDLE (12) THROUGH HOLE IN CABINET AND ENGAGE WITH PINION SHAFT. CRANK ONE COMPLETE TURN COUNTER CLOCK-WISE THUS EXTENDING PISTON ROD UNTIL HOLE (14) IS IN LINE WITH UPPER HOLE IN ROD (13).

STEP 7

PLACE PIN (11) INTO HOLE (14) TEMPORARILY. NOW REMOVE PIN (15), CONTINUE TO CRANK UNTIL PISTON (16) EMERGES FROM THE TOP OF THE CYLINDER. LIFT OUT CAREFULLY BY HAND. THOROUGHLY CLEAN PISTON AND CYLINDER TO REMOVE ALL ACCUMULATED DOUGH WITH A MILD SOAP AND WATER SOLUTION. DRY THOROUGHLY AND COAT ALL SURFACES WITH A LIGHT COATING OF DIVIDER OIL. TO REASSEMBLE, REVERSE STEPS 1 THROUGH 7.

WHEN CLEANING OR ADJUSTING PISTON, DO NOT OVER TIGHTEN ADJUSTING NUTS. THIS WILL OVER SPREAD YOUR PLASTIC PISTON RING AND WILL CAUSE EXCESSIVE WEAR. THIS WILL ALSO BE HARD TO PLACE PISTON BACK INTO THE CYLINDER. THIS COULD ALSO RESULT IN THE CUTTING OF YOUR PISTON RING AND DESTROYING IT.

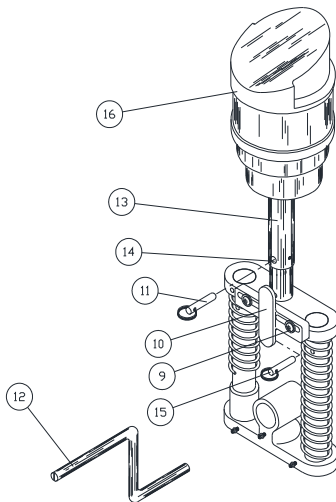

FIGURE 3

IMPORTANT: WHEN RE-ASSEMBLING, DO NOT OVER TIGHTEN ANY OF THE SCREWS, AS THIS TENDS TO STRIP THREADS CAUSING PROBLEMS IN THE FUTURE. BE SURE RING ON PIN (11) OF FIGURE 3 IS SECURELY FASTENED OVER LATCH (10). THIS WILL PREVENT LATCH FROM MOVING, SHOULD THE SOCKET HEAD SCREWS (9) LOOSEN DURING OPERATION.



DANGER:

ALWAYS DISCONNECT ELECTRICAL POWER SOURCE WHEN CLEANING, MAINTAINING OR REPAIRING THIS MACHINE....

REPLACEMENT OF PISTON RING

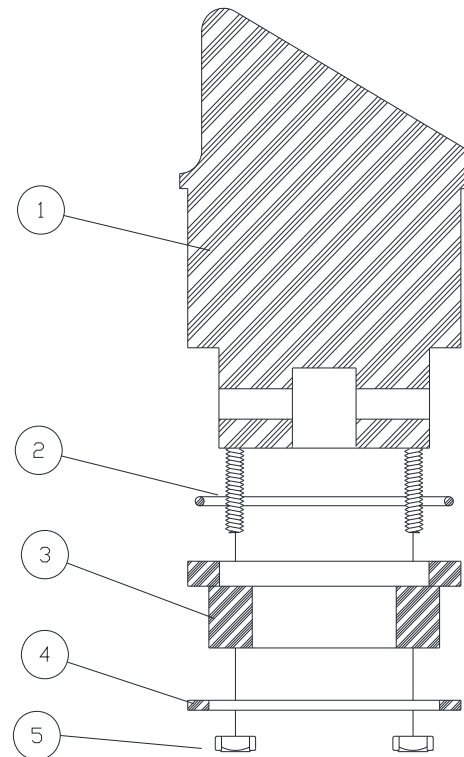

FIGURE 4

TO DISMANTLE PISTON IN FIGURE 4, REMOVE THE SIX NYLOCK HEX NUTS (5), SLIDE SLIP RING (2) DOWN AND OFF, THEN WITH SLIGHT PRESSURE, PUSH PISTON RING (3) OFF PISTON AND REMOVE RUBBER "O" RING (2). WHEN REASSEMBLING THE PISTON, A VERY **IMPORTANT** STEP IS TO MAKE SURE THE SIX NUTS (6) ARE NOT OVERLY TIGHTENED, MERELY SNUG. AS THE RING WEARS OVER A PERIOD OF TIME, CONTINUE TO SNUG UP THE SIX NUTS. THIS PROCEDURE WILL NOT ONLY PROVIDE LONG LIFE TO THE PISTON RING BUT WILL MAINTAIN FULL VACUUM. **FINAL ADJUSTMENT OF PISTON SHOULD BE MADE ONCE PISTON IS SECURE INSIDE THE CYLINDER!!**

GUIDE TO CLEANING

 DANGER:

ALWAYS DISCONNECT ELECTRICAL POWER SOURCE WHEN CLEANING, MAINTAINING OR REPAIRING THIS MACHINE...

LOWER LARGE CONVEYOR BEFORE MOVING OR RELOCATING MACHINE...

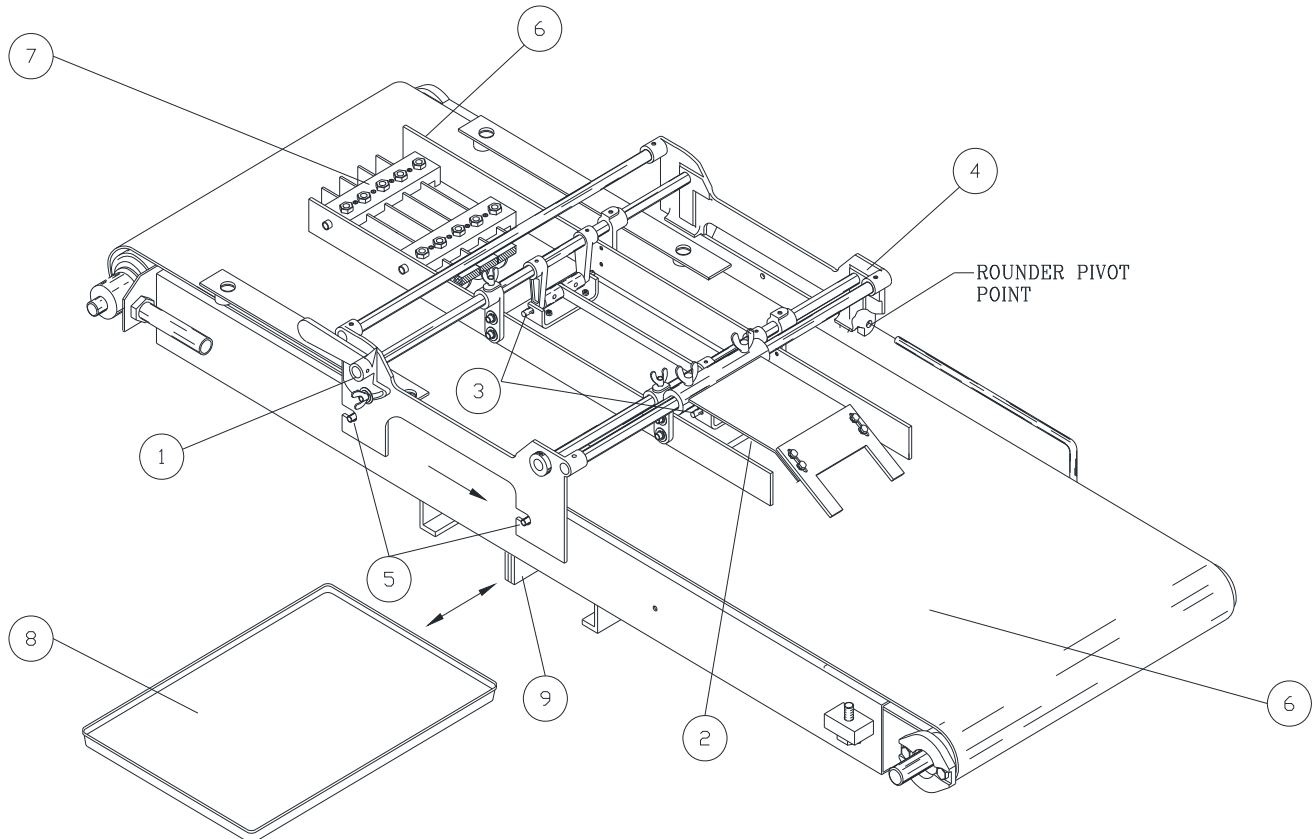

STEP 1

RAISE PRESSURE PLATE ASSEMBLY (1). SLIDE PRESSURE PLATE (2) TOWARDS DIVIDER UNIT UNTIL DISENGAGED FROM THE PRESSURE PLATE MOUNTING RODS (3).

CAUTION:

THIS STEP MUST BE PERFORMED FIRST TO PREVENT PRESSURE PLATE FROM SLIPPING OFF.

STEP 2

SLIDE MOUNTING FRAME (4) TOWARDS DIVIDER UNIT UNTIL IT DISENGAGES FROM SPACER (5). PIVOT MOUNTING FRAME (4) UP UNTIL IT RESTS IN CLEANING POSITION. CLEAN GUIDES (6) AND CUTTER ASSEMBLY (7).

STEP 3

CLEAN PRESSURE PLATE (2).

STEP 4

REMOVE EXCESS DOUGH FROM BELT.

STEP 5

SET PRESSURE PLATE (2) IN POSITION ON BELT.

STEP 6

PIVOT MOUNTING FRAME (4) DOWN, CAREFULLY ALIGNING PRESSURE PLATE (2) INTO POSITION BETWEEN GUIDES.

STEP 7

POSITION PRESSURE PLATE (2) ONTO PRESSURE PLATE MOUNTING RODS (3)

STEP 8

SLIDE MOUNTING FRAME (4) BACK ONTO SPACER (5).

STEP 9

REMOVE CRUMB TRAY (8) BY SLIDING IT OUT FROM UNDER CONVEYOR.

STEP 10

TO CLEAN THE SCRAPER BLADE (9), LOCATE BLADE UNDERNEATH THE CONVEYOR AND REMOVE EXCESS DOUGH.

GUIDE TO GENERAL MAINTENANCE

READ AND FOLLOW MAINTENANCE INSTRUCTIONS TO HELP KEEP THE UNIT IN GOOD OPERATING CONDITION. REFER TO OTHER MATERIALS RECEIVED WITH THE UNIT AND TO SERVICE BULLETINS FROM THE MANUFACTURER FOR ADDITIONAL INSTRUCTIONS FOR PROPER MAINTENANCE AND SERVICE. REGULAR INSPECTIONS AND PROPER MAINTENANCE ARE ESSENTIAL TO HELP PREVENT ACCIDENTS AND INJURIES.



PRACTICE SAFETY FIRST:

ALWAYS DISCONNECT ELECTRICAL SERVICE WHEN CLEANING OR MAINTAINING THIS MACHINE, THUS AVOIDING CHANCE OF SERIOUS INJURIES. MACHINES ARE NOT DANGEROUS IF COMMON SENSE IS APPLIED AND THE INSTRUCTIONS ARE CAREFULLY FOLLOWED. THINK AND PRACTICE SAFETY FIRST...



WARNING:

BEFORE MAKING ANY INSPECTION, ADJUSTMENT OR REPAIR, BE CERTAIN POWER SOURCE IS DISCONNECTED AND ALL MOVING PARTS ARE BLOCKED OUT TO PREVENT INJURY. WEAR PROTECTIVE CLOTHING.

- A. ALL WORKING SURFACES SHOULD BE CLEANED REGULARLY.
- B. THE TABLE TOP AND OTHER WORKING SURFACES SHOULD BE CLEANED REGULARLY.
- C. MAKE SURE THAT ALL FASTENERS ARE TIGHTENED SECURELY.
- D. MAKE CERTAIN THAT ALL GUARDS AND COVERS ARE IN PLACE.
- E. CHECK FOR WORN, DAMAGED OR MISSING PARTS INCLUDING BELTS, SAFETY GUARDS AND PROTECTIVE COVERS.
- F. ON A DAILY BASIS, INSPECT THE UNIT AND CHECK TO BE CERTAIN THAT ALL SYSTEMS ARE OPERATING NORMALLY. DETAILED INSPECTION AND TESTING PROCEDURES ARE SPECIFIED FOR VARIOUS COMPONENTS AT REGULAR INTERVALS. SET UP A CHART AND ASSIGN RESPONSIBILITY FOR THESE ITEMS.



CAUTION:

REPLACE ANY DAMAGED OR MISSING SAFETY LABELS. THEY ARE AVAILABLE FROM THE MANUFACTURER.

MAINTENANCE FOR THE SCALE-O-MATIC S502 ALWAYS BEGINS WITH KEEPING THE MACHINE CLEAN. PROPER CLEANING PROCEDURES CAN BE FOUND ON PAGES 9-12 OF THIS MANUAL. STANDARD LONG TERM MAINTENANCE CONSISTS OF LUBRICATING MAIN WEAR POINTS OF THE MACHINE WITH AN ALL-PURPOSE SYNTHETIC BASE GREASE. A GREASE GUN WITH A FLEXIBLE HOSE IS NEEDED.

ALL RECOMMENDATIONS FOR MAINTENANCE, BASED ON A 7 DAY, 8 HOUR PER DAY WORK SCHEDULE.



THERE ARE (5) GREASE FITTINGS LOCATED ON THE ROCKER ARM AND DIVIDER FRAME, (FIG. 1). THESE FITTINGS SHOULD BE LUBRICATED BI-WEEKLY FOR OPTIMUM BEARING LIFE.

FOLLOW NORMAL CLEANING AND MAINTENANCE PROCEDURES OUTLINED IN THIS MANUAL. FOR FURTHER ASSISTANCE CONTACT THE A.M. MFG. SERVICE DEPARTMENT AT (800) 342-6744...

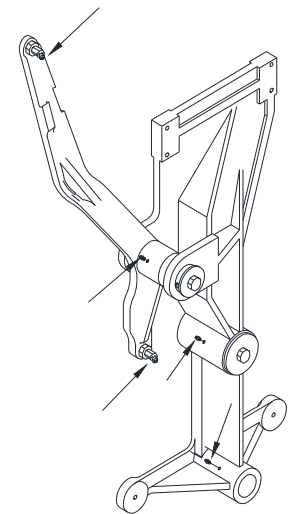

FIGURE 1

GUIDE TO GENERAL MAINTENANCE



DANGER:

ALWAYS DISCONNECT ELECTRICAL SERVICE WHEN CLEANING, MAINTAINING OR REPAIRING THIS MACHINE...

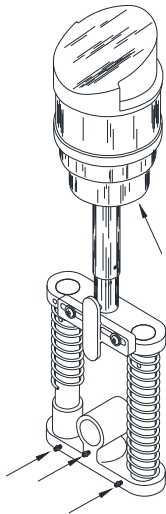
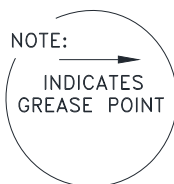

FIGURE 2

THE PISTON AND SPRING LOAD ASSEMBLY HAVE A TOTAL OF (4) GREASE FITTINGS, (FIG. 2). THREE (3) OF THESE FITTINGS ARE FOUND ON THE LOWER CASTING OF THE SPRING LOAD. APPLY A SMALL AMOUNT OF GREASE TO THESE FITTINGS ONCE A WEEK. THE SAME PROCEDURE SHOULD BE FOLLOWED FOR THE GREASE FITTING UNDER THE PISTON, (FIG. 4). THIS FITTING IS LOCATED ON THE TOP OF THE OUTSIDE CONNECTING ROD, (PART NO. 322PY).

NOTE:

THIS FITTING CAN ONLY BE REACHED WITH A FLEXIBLE HOSE GREASE GUN OR BY REMOVING THE PISTON.



YOU MAY FIND UPON INSPECTION OF THE PISTON THAT THE DOUGH HAS SEEPED INTO THE CUP. THIS IS A NORMAL OCCURRENCE AFTER MODERATE PRODUCTION. TO KEEP THE RUBBER "O" RING FROM PREMATURELY DETERIORATING, STRETCHING OR BREAKING, INSPECT AND CLEAN EVERY (4) WEEKS IN THE FOLLOWING MANNER, (FIG. 3). DISASSEMBLE THE PISTON BY REMOVING THE HEX NUTS ON THE BASE OF THE PISTON ASSEMBLY. REMOVE THE STEEL WASHER (PART NO. 302PY) AND PLASTIC PISTON RING (PART NO. 323PY). CAREFULLY CLEAN EXCESS DOUGH FROM THE PISTON AND "O" RING. REASSEMBLE THE PISTON BEING CAREFUL NOT TO OVERTIGHTEN THE PISTON RING.

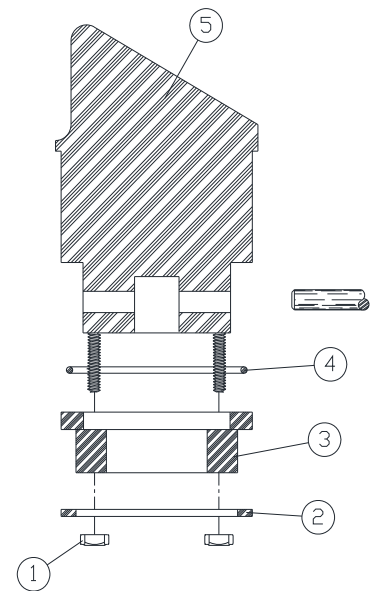
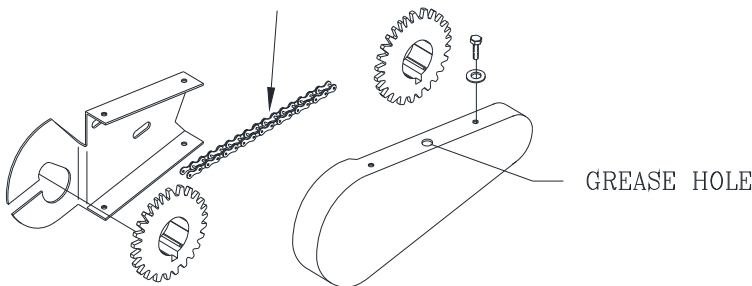

FIGURE 3



THE S502 SCALE-O-MATIC HAS A SINGLE DRIVE CHAIN (PART NO. 117RC). THIS PART MUST BE OILED REGULARLY WITH A LIGHT WEIGHT MACHINE OIL TO PROLONG THE LIFE OF THE SPROCKETS, AS WELL AS THE CHAIN. CHAIN CONDITION AND TENSION SHOULD BE CHECKED EVERY (60) DAYS OR MORE IF EXCESS NOISE OR VIBRATION IS NOTICED.

FOLLOWING NORMAL CLEANING AND MAINTENANCE PROCEDURES OUTLINED IN THIS MANUAL. FOR FURTHER ASSISTANCE CONTACT THE A.M. MFG. SERVICE DEPARTMENT AT (800) 342-6744...

NOTE: THESE INSTRUCTIONS WILL HELP YOU SERVICE THE UNIT. INSTRUCTIONS ARE FOR A PERSON WITH SOME MECHANICAL ABILITY AND TRAINING. NO ATTEMPT HAS BEEN MADE TO DESCRIBE ALL BASIC STEPS, FOR EXAMPLE, HOW TO LOOSEN OR TIGHTEN FASTENERS. ALSO, BASIC PROCEDURES LIKE HOW TO CYCLE SYSTEMS AND CHECK OPERATION OF THE EQUIPMENT ARE NOT DESCRIBED SINCE THEY ARE KNOWN TO ANYONE WHO DOES MECHANICAL AND SERVICE WORK. DO NOT ATTEMPT TO PERFORM WORK BEYOND YOUR ABILITY OR AT WHICH YOU HAVE NO EXPERIENCE. IF YOU NEED ASSISTANCE, CALL AN AUTHORIZED SERVICE CENTER OR CONTACT A.M. MANUFACTURING AT (800) 342-6744.

**THIS PAGE HAS BEEN
INTENTIONALLY LEFT BLANK**

HOPPER COVER (STANDARD)

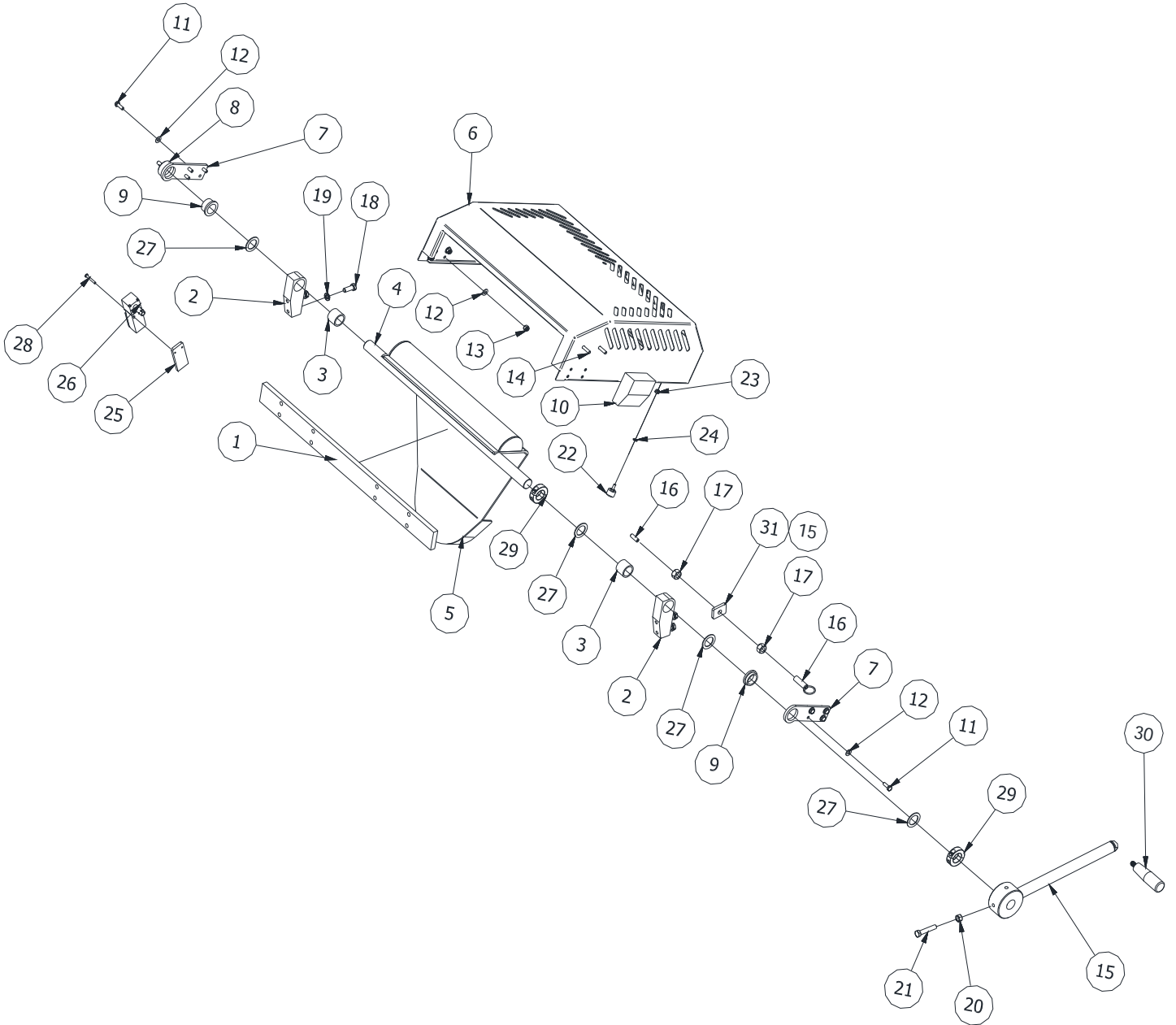

HOPPER COVER (STANDARD)

ITEM	PART NUMBER	DESCRIPTION	QTY
1	17832	SAFETY COVER MOUNTING BAR	1
2	17828	SAFETY COVER HINGE BASE	2
3	20614	OIL IMPREGNATED SLEEVE BUSHING (1.002 ID X 1.253 OD X 1" LONG)	2
4	17890	SAFETY COVER PIVOT SHAFT (PURCHASE AS ASSEMBLY W/ 17827)	1
5	17827	DOUGH FEED PLATE ASSEMBLY (PURCHASE AS ASSEMBLY W/ 17890)	1
6	17834	HOPPER SAFETY COVER	1
7	17842	HOPPER SAFETY COVER HINGE PLATES	2
8	17888	SAFETY COVER SAFETY SWITCH ADAPTER (PUCHASED AS ASSEMBLY W/ 17842)	1
9	20453	OIL IMPREGNATED FLANGE BUSHING (1.002 ID X 1.253 OD X 3/4" LONG)	2
10	19475	SAFETY COVER PIVOT LOCK BLOCK	1
11	F0403HHCS	HEX HEAD CAP SCREW 1/4-20 X 3/4"	8
12	F0400FW	FLAT WASHER, 1/4"	16
13	F0400NLN	NUT, NYLOCK 1/4"	8
14	F0404SB	BUTTON HEAD, SOCKET 1/4-20 X 1" LG	2
15	17824	SAFETY COVER DOUGH HANDLE ASSY.	1
16	20432	SPRING PLUNGER w/ PULL RING	1
17	F0800NC	NUT, 1/2-13 NORMAL	2
18	F0604HHCS	HEX HEAD CAP SCREW 3/8-16 X 1"	4
19	F0600LW	LOCK WASHER 3/8"	4
20	F0600NC	NUT, 3/8	1
21	F0608HHCS	HEX HEAD CAP SCREW 3/8-16 X 2" LG	1
22	11832	BUMPER, THREADED STUD W/HEX SHOULDER	2
23	F9900NLN	NYLOCK NUT, #10-32	2
24	F9900FW	FLAT WASHER, # 10	2
25	19220	SAFETY SWITCH MOUNT PLATE	1
26	EL-1320	SAFETY SWITCH - ROTARY HINGE - 2NC	1
27	20615	NYLON WASHER (1.003" I.D. X 1-1/2" O.D. X 1/16" THICK)	4
28	F9705PHS	Pan Head, Slotted, 8-32 UNC x 1-1/4	2
29	20616	1" S.S. SPLIT SHAFT COLLAR (2 PIECE)	2
30	17825	SAFETY COVER HANDLE HUB	1
31	19476	SNAP PIN MOUNTING TAB	1
32	11467	Easy-Turn Revolving Handle 3/8"-16 THREAD Stud, 1.10" Dia, 3.54" LG	1

HOPPER COVER (EXTENDED HOPPER)

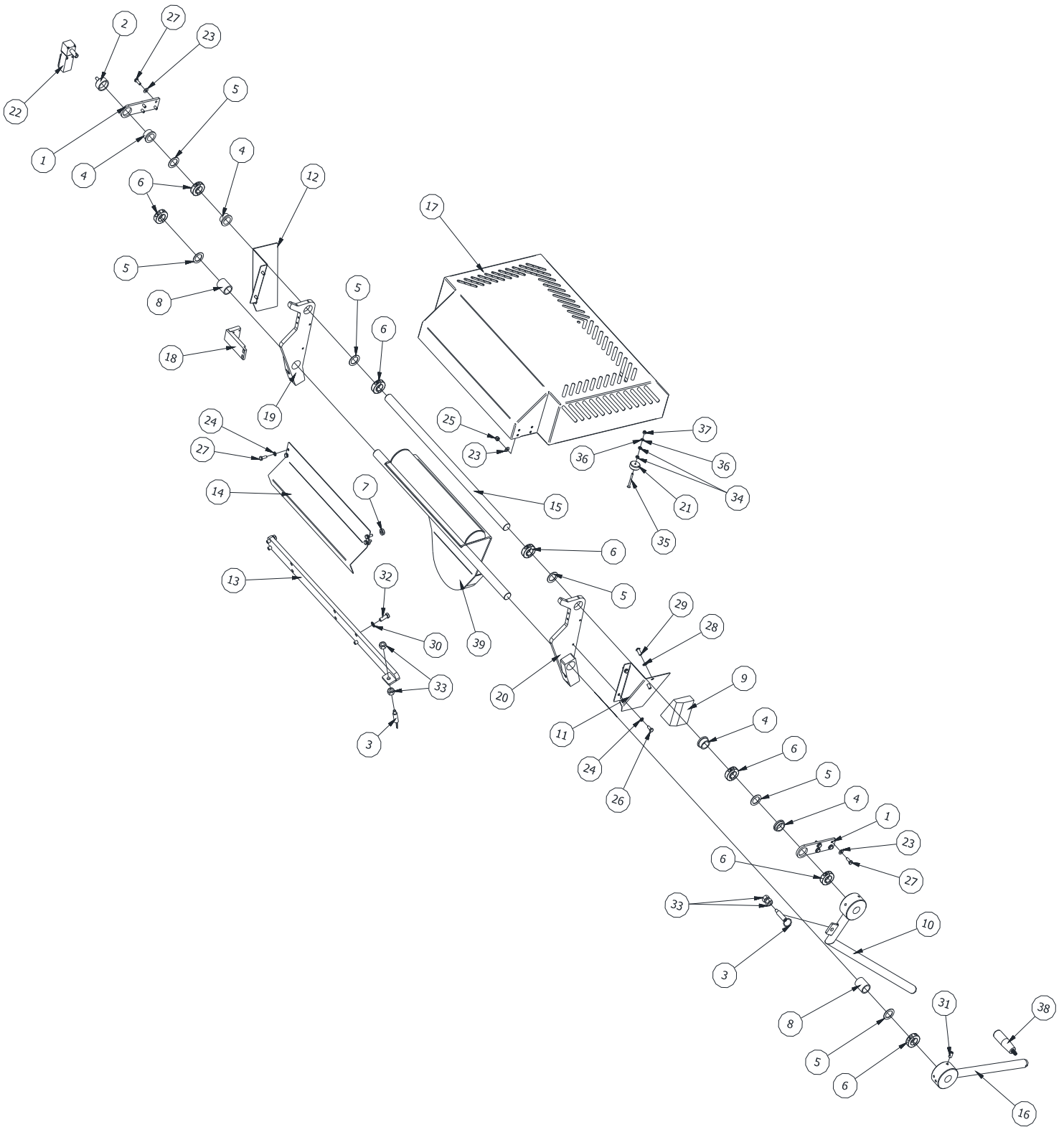

HOPPER COVER (EXTENDED HOPPER)

ITEM	PART NO	DESCRIPTION	QTY
1	17842	HOPPER SAFETY COVER HINGE PLATES	2
2	17888	SAFETY COVER SAFETY SWITCH ADAPTER	1
3*	20432	SPRING PLUNGER w/ PULL RING	2
4	20453	OIL IMPREGNATED FLANGE BUSHING (1.002 ID X 1.253 OD X 3/4" LONG)	4
5	20615	NYLON WASHER (1.003" I.D. X 1-1/2" O.D. X 1/16" THICK)	6
6	20616	1" S.S. SPLIT SHAFT COLLAR (2 PIECE)	7
7	20645	SPACER (3/4" O.D. X 1/4" LONG w/ 9/32 THRU HOLE)	2
8	20649	OIL IMPREGNATED SLEEVE BUSHING (1.002 ID X 1.253 OD X 1.5" LONG)	2
9	20650	SPRING PIN LOCK BLOCK	1
10	20651	SAFETY COVER HANDLE ASSEMBLY	1
11	20657	HOPPER GUARD (LEFT SIDE)	1
12	20658	HOPPER GUARD (RIGHT SIDE)	1
13	20660	SAFETY COVER MOUNTING BAR ASSEMBLY	1
14	20661	HOPPER BACK GUARD	1
15	20662	SAFETY COVER PIVOT SHAFT	1
16	20663	SAFETY COVER DOUGH HANDLE ASSY.	1
17	20665	EXTENDED HOPPER SAFETY COVER	1
18	20666	INTERLOCK SWITCH MOUNT BRACKET ASSEMBLY	1
19	20669	SAFETY COVER HINGE BAR (RIGHT SIDE)	1
20	20670	SAFETY COVER HINGE BAR (LEFT SIDE)	1
21	20671	HOPPER COVER BUMPER	2
22	EL-1320	SAFETY SWITCH - ROTARY HINGE - 2NC	1
23	F0400FW	FLAT WASHER, 1/4"	16
24	F0400LW	LOCK WASHER, 1/4"	8
25	F0400NLN	NUT, NYLOCK 1/4"	8
26	F0402.5HHCS	HEX HEAD CAP SCREW 1/4-20 X 5/8"	4
27	F0403HHCS	HEX HEAD CAP SCREW 1/4-20 X 3/4"	12
28	F0500LW	LOCK WASHER, 5/16"	2
29	F0503SB	SOCKET BUTTON HEAD, 5/16-18 X 3/4" LG	2
30	F0600LW	LOCK WASHER 3/8"	4
31	F0603SS	3/8-16 S.S. SET SCREW 3/4" LONG	2
32	F0604HHCS	HEX HEAD CAP SCREW 3/8-16 X 1"	4
33*	F0800NC	NUT COURSE, 1/2-13 NORMAL	4
34	F9800NC	NUT COURSE, #10-24	4
35	F9808FSH	10-24 X 2" LONG FLAT SOCK HEAD SCREW	2
36	F9900FW	FLAT WASHER, # 10	2
37	F9900NLN	NYLOCK NUT, #10-32	2
38	11467	Easy-Turn Revolving Handle 3/8"-16 Thrd Stud, 1.10" Dia, 3.54" LG	1
39	20810	DOUGH FEED PLATE & SHAFT ASSEMBLY	1

* ITEMS 3 & 33 ARE SOLD AS A UNIT. SHOWN APART FOR CLERTY

DIVIDER SLIDE GUARD

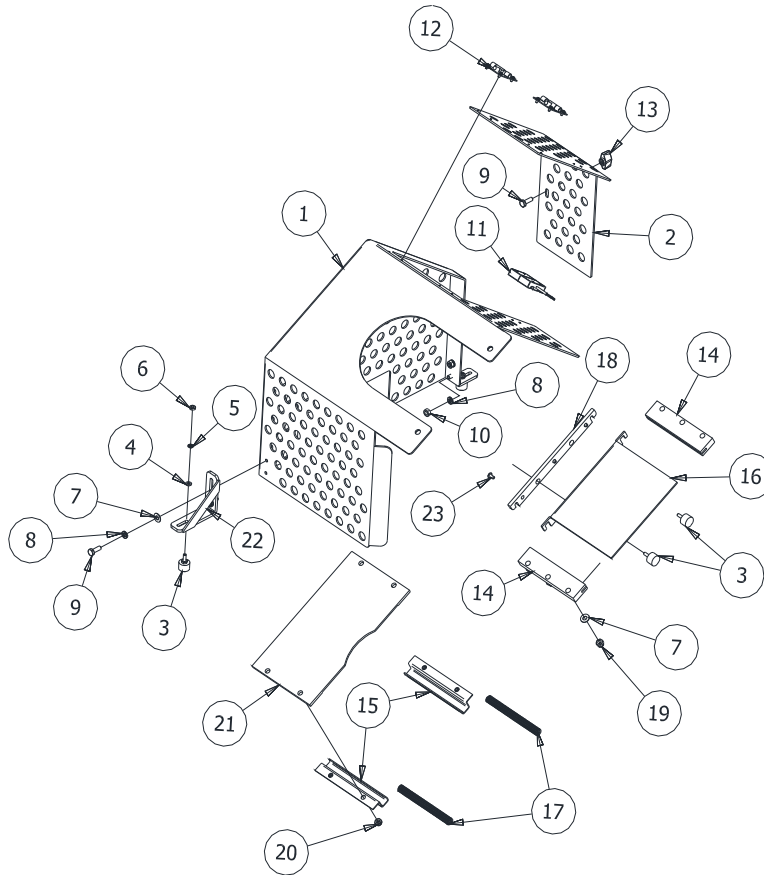

ITEM	PART NO	DESCRIPTION	QTY
1	21490	SLIDE AND DROP CONV. SAFETY GUARD MAIN BODY	1
2	21491	SLIDE AND DROP CONV. SAFETY COVER DOOR	1
3	11832	BUMPER, THREADED STUD W/HEX SHOULDER	4
4	F9900FW	FLAT WASHER, # 10	2
5	F9900LW	LOCK WASHER, #10	2
6	F9900NF	NUT FINE, MACH SCREW #10-32, S.S.	2
7	F0400FW	FLAT WASHER, 1/4"	10
8	F0400LW	LOCK WASHER, 1/4"	8
9	F0403HHCS	HEX HEAD CAP SCREW 1/4-20 X 3/4"	5
10	F0400NC	NUT COURSE, 1/4-20	4
11	EL-1308	SAFETY SWITCH - ACTUATOR	1
12	11831	Quick-Disconnect Latch Hinge	1
13	F0400PWN	PLASTIC WING NUT (1/4-20)	1
14	11824	GUARD SLIDE TRACK	2
15	11825	SPRING RETAINER	2
16	11823	GUARD SLIDE	1
17	11830	SPRING 1/2" OD X 5" LG	2
18	12114	GUARD SLIDE ADAPTER	1
19	F0400NLN	NUT, NYLOCK 1/4"	6
20	F0400NLNT	NUT, NYLOCK 1/4", THIN	4
21	11826	SLIDE SPACER	1
22	21580	DROP CONVEYOR GUARD SUPPORT BRACKET SLIDE SIDE	1
23	F9701.5TH	8-32 X 3/8" LONG TRUSS HEAD	3

NOTE:
 GUARD CAN BE PURCHASED AS A COMPLETE UNIT. **PART #: 21492**

**THIS PAGE HAS BEEN
INTENTIONALLY LEFT BLANK**

CABINET ASSEMBLY

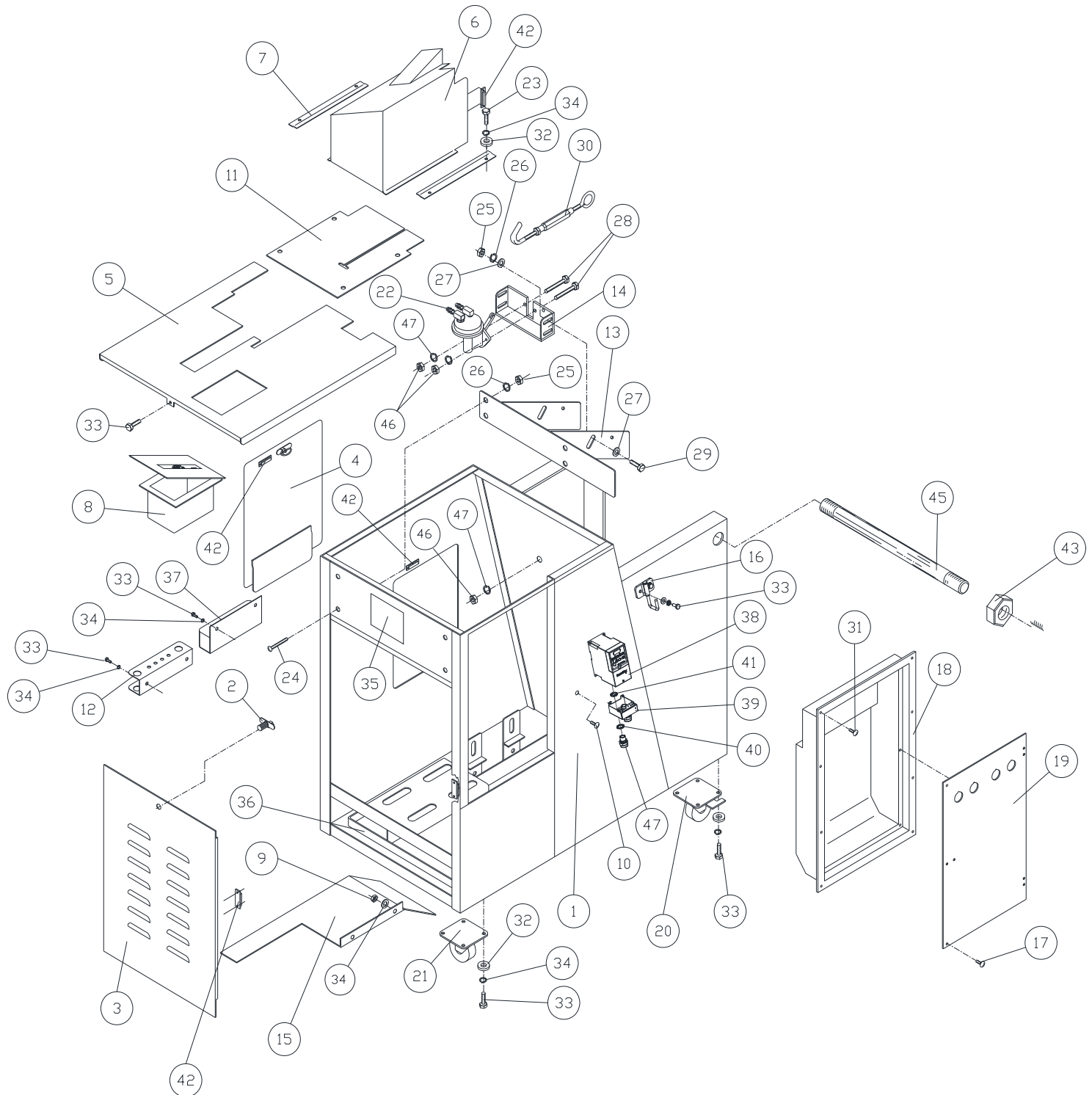

CABINET ASSEMBLY

ITEM	PART NO.	DESCRIPTION	QTY.
1	15160	CABINET	1
2	646CA1	DOOR LOCK LATCH W/2 POP RIVETS	2
3	CA602A	615CA REAR DOOR (INSPECTION) W/646CA1 HARDWARE	1
4	11810	11810 FRONT DOOR PISTON DRIVE W/646CA1 HARDWARE	1
5	602CA-C	TOP COVER	1
6	641CA	ROCKER ARM SAFETY COVER/	1
7	640CA	ROCKER ARM COVER TRACK	2
8	604CA	OIL BOX AND COVER	1
		INCLUDES:	
		1 – 604CA-1 OIL BOX COVER	
		1 – 604CA-2 OIL BOX	
		1 – 713OS STAINER w/ INSERT – FILTER ADAPTER	
		1 – AM TAG #OM DIVIDER OIL TAG	
9	F0400NC	1/4-20 NUT	2
10	F0402TH	1/4-20 TRUSS HEAD SCREW	2
11	641CA1	ROCKER ARM COVER GASKET	1
12	638CA	TOOL HOLDER	1
13	605CA1	PUMP BRACKET (LARGE)	1
14	605CA2	PUMP BRACKET (SMALL)	1
15	643CD	"V" BELT GUARD	1
16	12059	GUARD HOOK ASSEMBLY	1
17	F9904PSM	#10 SHEET METAL SCREW	3
18	617CA6	ELECTRICAL ENCLOSURE	1
19	11423	ELECTRICAL COVER PANEL	1
20	621CA1	SWIVEL CASTER (LOCKING)	2
21	621CA2	SWIVEL CASTER	2
22	716OS	OIL PUMP ASSEMBLY	1
		INCLUDES:	
		1 - 1440S BEARING	
		1 – F0403SH SOCKET HEAD CAP SCREW	
		1 – F0400LN LOCK NUT	
23	F0404HH	1/4-20 X 1" LONG HEX HEAD BOLT	4
24	F0503CB	5/16-18 CARRAGE BOLT	4
25	F500NC	5/16-18 NUT	8
26	F0500LW	5/16" LOCK WASHER	8
27	F0500FW	5/16" FLAT WASHER	8
28	F0606HH	3/8-16 X 1-1/2" LONG HEX HEAD BOLT	2
29	F0504HH	5/16-18 HEX HEAD BOLT	4
30	654CA	TURN BUCKLE	1
31	F9702TH	8-32 X 1/2" LONG TRUSS HEAD SCREW	10
32	F0400FW	1/4" FLAT WASHER	22
33	F0402.5HH	1/4-20 X 5/8" LONG HEX HEAD BOLT	22
34	F0400LW	1/4" LOCK WASHER	31
35	TAG 204M	ELECTRICAL NAMEPLATE	1
36	19905	OIL PAN (FOR DOUGH)	1
37	11866	NUT BOX	1
38	EL-0924	VARIABLE FREQUENCY DRIVE - 240VAC (STANDARD)	1
	EL-0972	VARIABLE FREQUENCY DRIVE – 208V – 230VAC SINGLE PHASE (OPTIONAL)	
	EL-0888	VARIABLE FREQUENCY DRIVE – 380V – 480VAC (OPTIONAL)	
39	EL-0925	VARIABLE FREQUENCY DRIVE CONVERSIONS KIT	1
40	EL-0118	1/2" SEAL GASKET	3
41	SS101	LOCK NUT (1/2" CONDUIT)	3
42	EL-1308	SAFETY SWITCH - COADED SWITCH / ACTUATOR	3 SETS
43	F1200NLN	1/2-13 NYLOCK NUT	2
44	SS275	CORD GRIP	3
45	628CA	CONVEYOR ARM ROD 3/4" DIA.	1
46	F0600NC	3/8-16 NUT	5
47	F0600LW	3/8 LOCK WASHER	5



IMPORTANT:
KNOW YOUR UNIT. COMPARE DIAGRAMS IN THIS MANUAL WITH THE UNIT BEFORE STARTING SERVICE TO OBTAIN MAXIMUM SAFETY AND PERFORMANCE.

NOTE: GUARDS ARE INTERLOCKED, MACHINE WILL NOT OPERATE UNLESS GUARDS ARE IN PLACE.

CYLINDER AND DRIVE ASSEMBLY

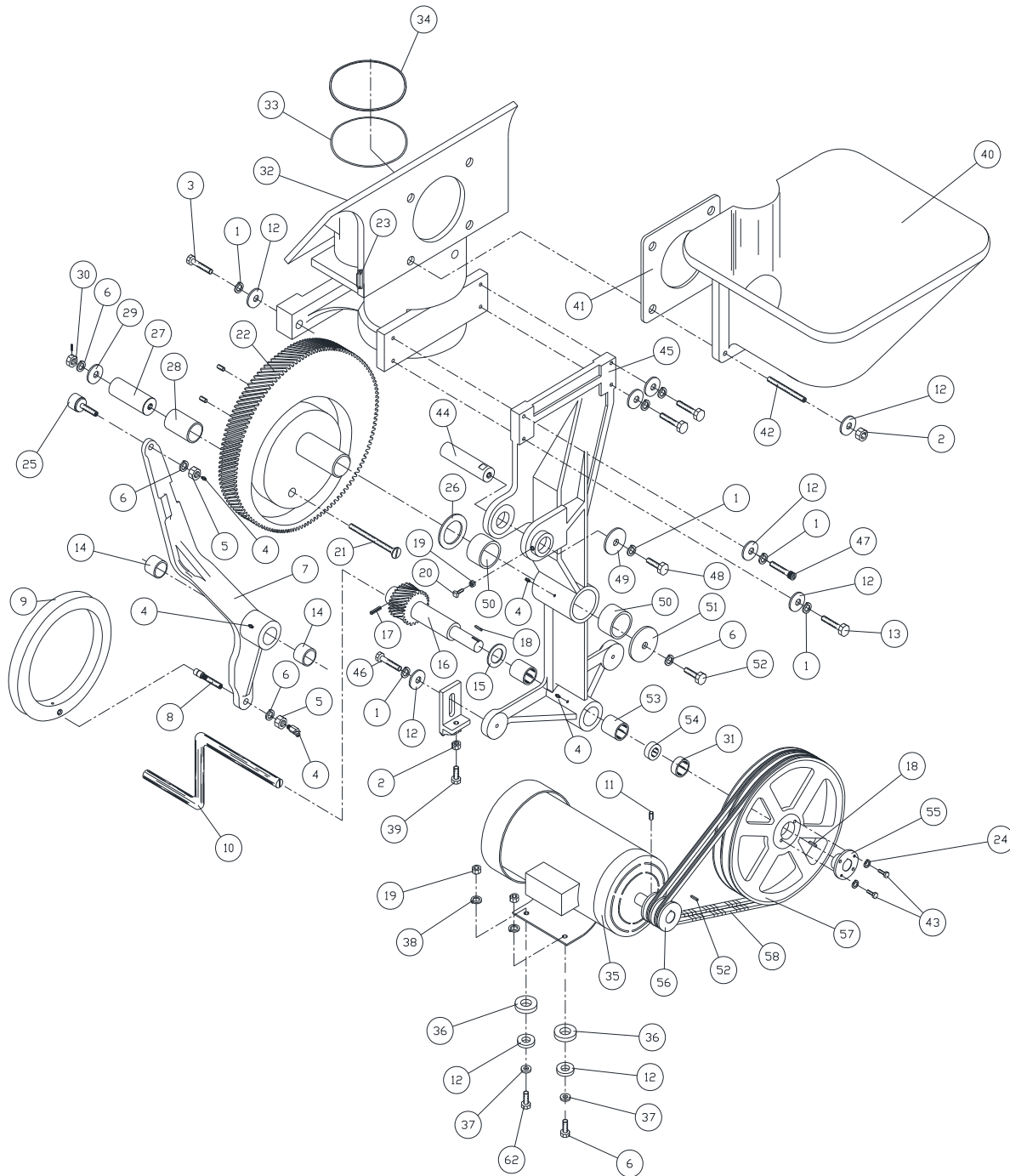

IMPORTANT:
KNOW YOUR UNIT. COMPARE DIAGRAMS IN THIS MANUAL WITH THE UNIT BEFORE STARTING SERVICE TO OBTAIN MAXIMUM SAFETY AND PERFORMANCE.

NOTE:
GUARDS ARE INTERLOCKED, MACHINE WILL NOT OPERATE WITHOUT GUARDS IN PLACE.

CYLINDER AND DRIVE ASSEMBLY

ITEM	PART NO	DESCRIPTION	QTY
1	F0600LW	LOCK WASHER	9
2	F0600NC	3/8-16 NUT	6
3	F0604HH	3/8-16 x 1" BOLT	2
4	3038-B	GREASE FITTING	5
5	F0800LNF	1/2-20 LOCK NUT	3
6	F0800LW	1/2" LOCK WASHER	5
7	S0110CD	ROCKER ARM COMPLETE	1
		INCLUDES:	
		1-412CD (CAM ARM PIN)	
		2-422CD (BEARINGS)	
		1-427CD (CAM ROLLER W/WASHER, NUT & GREASE FITTING)	
		1-448CDA (HEAVY DUTY CAM TRACK SHOE)	
8	A452CD	SHOE BOLT w/ 1/2" WASHER, 1/2-20 NYLOCK NUT & GREASE FITTING	1
9	448CDA	HEAVY DUTY CAM TRACK SHOE	1
10	426CD	HAND CRANK	1
11	F0501SS	SET SCREW	1
12	F0600FW	3/8" FLAT WASHER	15
13	F0607HH	3/8-16 X 1-3/4" HEX HEAD BOLT	3
14	422CD	ROCKER ARM BEARING	2
15	411CD	WASHER SPACER	1
16	415CD	DRIVE SHAFT & PINION	1
		INCLUDES:	
		1-F0404KY (1/4" X 1" LONG KEY)	
		1-F0305RP (5/16 X 1-1/4" LONG ROLL PIN)	
17	F0305RP	ROLL PIN	1
18	F0404KY	KEY W/ 415CD	1
19	F0500NC	5/16-18 NUT	5
20	F0506SQ	BOLT	1
21	F0819FH	1/2-13 X 4-3/4" LONG FLAT HEAD	1
22	S0113CD	MAIN DRIVE GEAR	1
		INCLUDES:	
		1-406CD (SHAFT YOKE PIN)	
		1-312PY (BEARING)	
		1-F0819FH (1/2-13 FLAT HEAD SCREW)	
		1-F0800NC (1/2-13 NUT)	
		1-409CD (SHAFT)	
		1-F0800LW (LOCK WASHER)	
1-459CD (SPACER)			
23	EL-1308	SAFETY SWITCH - COADED SWITCH / ACTUATOR	1
24	F0400LW	1/4" LOCK WASHER	2
25	A427CD	CAM ROLLER w/ 1/2" WASHER, 1/2-20 LOCK NUT & GREASE FITTING)	1
26	411CD	SPACER WASHER	1
27	406CD	SHAFT YOKE PIN (SOLD WITH S0133CD ONLY)	1
28	312PY	DRIVE BEARING	1
29	459CD	SPACER	1
30	F0800NC	1/2-13 NUT	1
31	464CD	SPACER	1

CYLINDER AND DRIVE ASSEMBLY CONTINUED

ITEM	PART NO	DESCRIPTION	QTY
32	AS0107CD	CYLINDER	1
		INCLUDES:	
		1-7080S (CHECK VALVE)	
		8-F0500NC (5/16-18 NUTS)	
		8-F0508SD (5/16-18 X 2" LONG STUDS)	
33	402CD	CYLINDER SLIDE "O" RING	1
34	401CD	SEAL SCRAPER RING	1
35	SS265	ELECTRIC MOTOR (208-230/460 Vac 60Hz & 190/380Vac 50Hz - 3 PHASE)(STANDARD)	1
	15256	ELECTRIC MOTOR (380Vac / 50Hz / 3 PHASE MOTOR (OPTIONAL)	
36	F0800FW	1/2" FLAT WASHER	4
37	F0500FW	5/16" FLAT WASHER	4
38	F0500LW	5/16" LOCK WASHER	4
39	F0608HH	3/8-16 HEX HEAD BOLT	2
40	445CD	DOUGH HOPPER	1
	445CDE	EXTENDED DOUGH HOPPER (OPTIONAL)	
41	449CD	HOPPER GASKET	1
42	F0607SD	STUD	4
43	F0404HH	1/4-20 X 1" LONG HEX HEAD BOLT	2
44	412CD	CAM ARM PIN	
45	S0109CD	MAIN DRIVE FRAME	1
		INCLUDES:	
		2-437CD PINION SHAFT BEARING	
		2-440CD MAIN FRAME BEARING	
		2-3038-B GREASE FITTING	
		2- NUTS	
46	F0606HH	3/8-16 HEX HEAD BOLT	2
47	F0609SH	3/8-16 X 2-1/4" LONG SOCKET HEAD BOLT	1
48	F0804HH	1/2-13 X 1" LONG HEX HEAD BOLT	1
49	442CD	WASHER, 1-3/4 X 3/8	1
50	440CD	MAIN FRAME BEARING	2
51	439CD	WASHER 3 X 9/16	1
52	F0304Y	KEY 3/16"	1
53	437CD	PINION SHAFT BEARINGS	2
54	465CD	BEARING	1
55	463CD	HUB-PULLEY W/ KEY	1
56	458CD	MOTOR PULLEY (DOUBLE GROOVE)	1
57	435CD2	DRIVE PULLEY(SINGLE GROOVE)	1
58	434CD49	"V" BELT (49")	1

**THIS PAGE HAS BEEN
INTENTIONALLY LEFT BLANK**

PISTON - CONNECTING ROD & SPRING ASSEMBLY

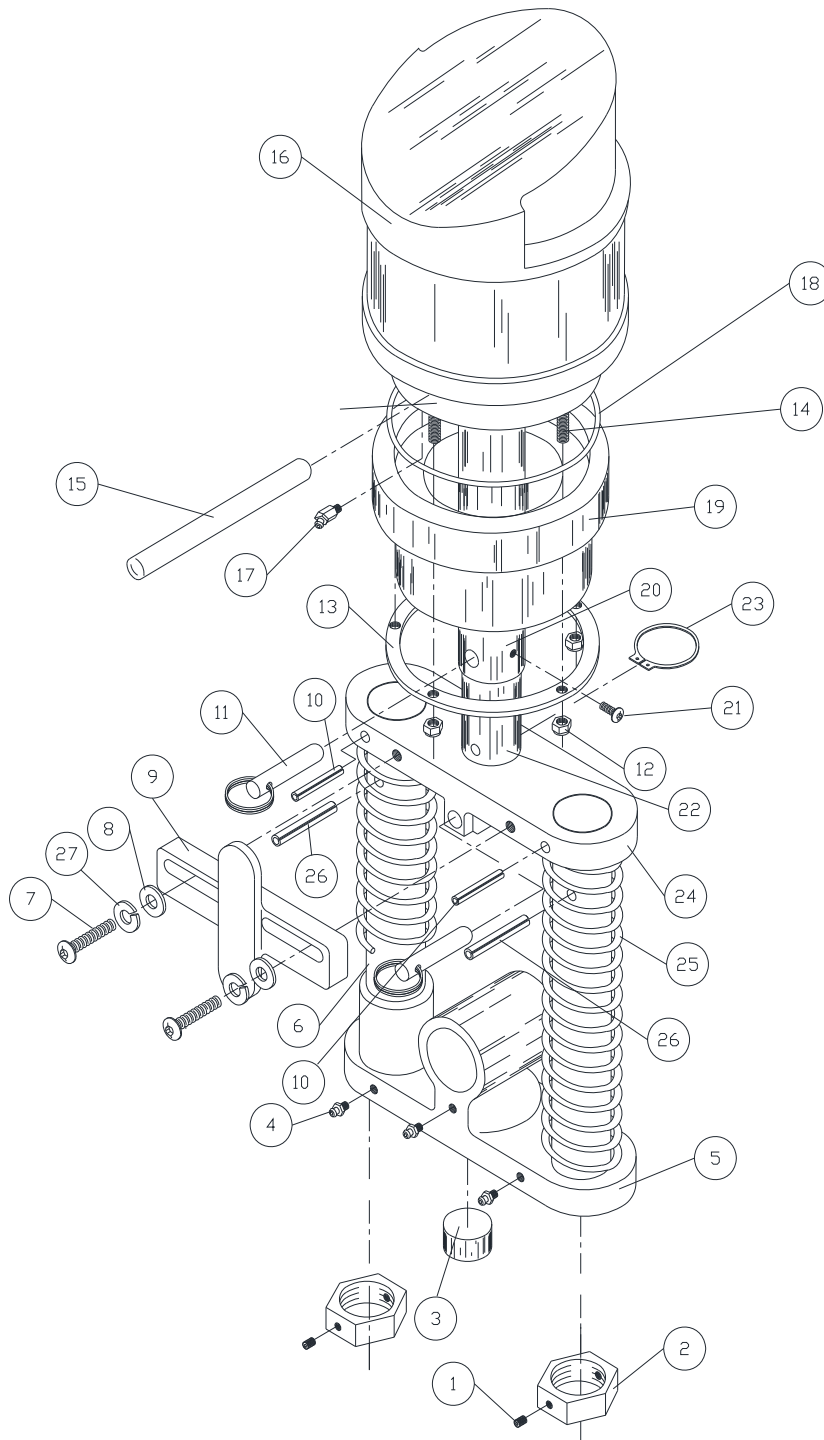

PISTON - CONNECTING ROD & SPRING ASSEMBLY

ITEM	PART NO	DESCRIPTION	QTY
1	F0401SS	SET SCREW	2
2	315PY	SPRING LOCK NUT	2
3	313PY	EXPANSION PLUG	1
4	3038-B	GREASE FITTING	3
5	310PY	LOWER CASTING & BUSHING W/ 3-3038-B GREASE FITTINGS	1
		1-313PY EXPANSION PLUG	
		SPRING GUIDE BARS (NOT SOLD SEPARATELY) SOLD W/B317PY ONLY	
6	309PY		2
7	F0404SB	BOLT	2
8	F0400FW	FLAT WASHER	2
9	306PY	LOCK CONNECTING PIN	1
10	F0408RP	ROLL PIN 1/4 DIA. X 2.0" LG.	2
11	304PY	CONNECTING ROD PIN	2
12	F0400LN	LOCK NUT	6
13	302PY	PISTON RING WASHER	1
14	F0416HS	HANGER SCREW	6
15	301PY	WRIST PIN	1
16	300PY	PLASTIC PISTON ASSEMBLY W/ 6-F0400LN	1
		LOCK NUTS,	
		1-301PY WRIST PIN	
		1-302PY PISTON RING WASHER	
		1-323PY PISTON RING ONLY	
		1-324PY O RING	
17	3053-B	GREASE FITTING	1
18	324PY	PISTON O RING	1
19	323PY	PISTON RING ONLY	1
20	322PY	OUTSIDE CONNECTING ROD	1
21	F0401SB	SOCKET-BUTTON HEAD SCREW	1
22	319PY	INSIDE CONNECTING ROD	1
23	318PY	TRU ARC RETAINER WASHER	1
24	317PY	UPPER SPRING CASTING W/ 2-F0406RP SPRING PINS	1
		2-309PY SPRING GUIDE BARS	
		2-F0408RP SPRING PINS	
		COMPRESSION SPRING	
25	316PYB		2
26	F0406RP	ROLL PIN 1/4 DIA. X 2.0" LG.	2
27	F0400LW	LOCK WASHER	2

ASSEMBLY PART #'S

A504PY CONNECTING ROD ASSEMBLY
 INCLUDES:

1 - 318PY TRU ARC RETAINER WASHER
 1 - 319PY INSIDE CONNECTING ROD
 1 - 322PY OUTSIDE CONNECTIONG ROD
 1 - F0401SB SOCKET BUTTON HEAD SCREW

A503AY SPRING LOAD ASSEMBLY
 INCLUDES:

2 - 306PY LOCK CONNECTING PIN
 3 - 3038-B GREASE FITTING
 1 - 310PY LOWER CASTING & BUSHING
 1 - 313PY EXPANSION PLUG
 2 - 316PY COMPRESSION SPRING
 1 - 317PY UPPER SPRING CASTING ASSEMBLY
 2 - 315PY SPRING LOCK NUT HARDWARE

MEASURING CUP & DIVIDER SLIDE

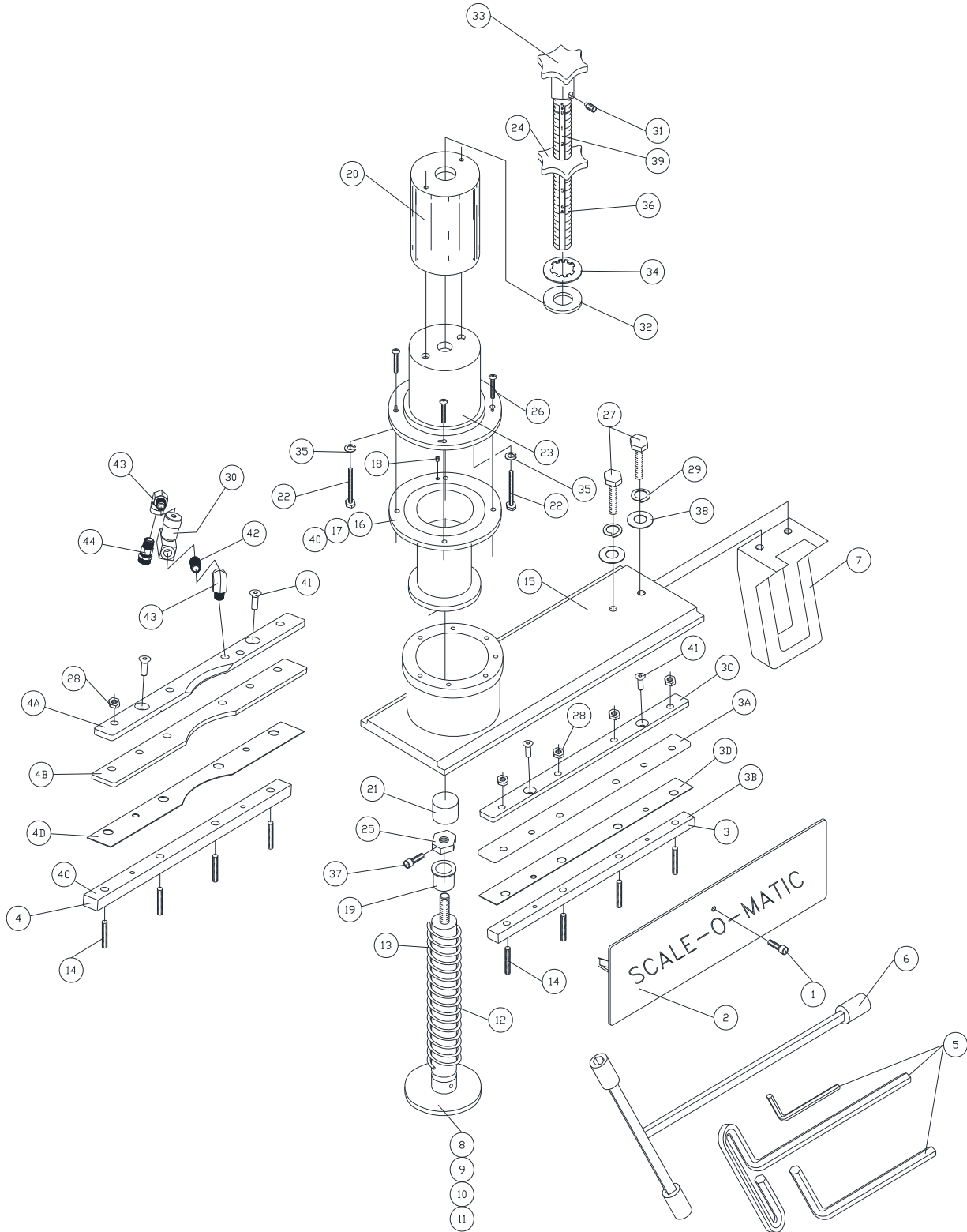

MEASURING CUP & DIVIDER SLIDE

ITEM	PART NO	DESCRIPTION	QTY	ITEM	PART NO	DESCRIPTION	QTY
1	F0404SH	SOCKET HEAD BOLT	1	12	516MSL	PLUNGER SPRING (LIGHT) FOR 1" & 2" PLUNGER	1
2	518MS	NAME PLATE & OIL RETURN	1	13	516MSH	PLUNGER SPRING (HEAVY) FOR 3" & 5" PLUNGER	1
3	21641	GIB BAR (LOWER) INCLUDES: 3A. 506MS-B (PLASTIC INSERT) 3B. 507MS (SPACER BAR) 3C. 520MS (GIB BAR, LOWER) 3D. 521MS-B (WEAR STRIP, LOWER)	1	14	F0508SD	STUD	8
4	21640	GIB BAR (UPPER) INCLUDES: 4A. 505MS (GIB BAR, TOP) 4B. 506MS-T (PLASTIC INSERT) 4C. 507MS (SPACER BAR) 4D. 521MS-T (WEAR STRIP, TOP) 1 - 724OS 90° STREET ELBOW	1	15	511MS	DIVIDER SLIDE	1
5	530MSW	WRENCHES 1/8", 1/16" AND 5/32" T-HANDLE	1 SET	16	509MSS	DIVIDER CYLINDER 2"	1
6	542MSW	T WRENCH	1	17	510MS	DIVIDER CYLINDER 3"	1
7	517MS 517MS/H	CAM ARM SLIDE w/ F0607HH SCREWS CAM ARM SLIDE w/ F0605HH HEAVY SCREWS	1 UNIT	18	F0401SS	SET SCREW	4
8	513MS-1 513MS-1S	1" PLUNGER INCLUDES: 1 - F0304RP ROLL PIN 1 - 515MS PLUNGER SHAFT 1" PLUNGER w/ SPRING INCLUDES: 1 - F0304RP ROLL PIN 1 - 515MS PLUNGER SHAFT 1 - 516MSL PLUNGER SPRING (LIGHT)	1 UNIT	19	539MSP	PLASTIC BUSHING	1
9	513MS-2 513MS-2S	2" PLUNGER INCLUDES: 1 - F0304RP ROLL PIN 1 - 515MS PLUNGER SHAFT 2" PLUNGER w/ SPRING INCLUDES: 1 - F0304RP ROLL PIN 1 - 515MS PLUNGER SHAFT 1 - 516MSL PLUNGER SPRING (LIGHT)	1 UNIT	20	529MS-2	STOP COVER	1
10	513MS-3 513MS-3S	3" PLUNGER INCLUDES: 1 - F0304RP ROLL PIN 1 - 515MS PLUNGER SHAFT 3" PLUNGER w/ SPRING INCLUDES: 1 - F0304RP ROLL PIN 1 - 515MS PLUNGER SHAFT 1 - 516MSH PLUNGER SPRING (HEAVY)	1 UNIT	21	529MS-2E	PLASTIC STOP PLUG	1
11	513MS-5 513MS-5S	5" PLUNGER INCLUDES: 1 - F0304RP ROLL PIN 1 - 515MS PLUNGER SHAFT 5" PLUNGER w/ SPRING INCLUDES: 1 - F0304RP ROLL PIN 1 - 515MS PLUNGER SHAFT 1 - 516MSH PLUNGER SPRING (HEAVY)	1 UNIT	22	F0416HH	BOLT	2
				23	503MS	PLUNGER GUIDE HOUSING	1
				24	529MS-2D	STAR KNOB	1
				25	531MS	SLOTTED HEX NUT	2
				26	F0404SB	SOCKET HEAD BOLT	4
				27	F0607HH	HEX HEAD BOLT	2
				28	F0500HNC	HEX NUT	8
				29	F0600LW	LOCK WASHER	2
				30	724OS	STREET ELBOW 90°	1
				31	F0502SSDP	SET SCREW w/ FULL DOG POINT	1
				32	F1200WF	WASHER	1
				33	529MS-2F-A	ADJUSTABLE HANDLE	1
				34	F1200RW	RETAINING WASHER	1
				35	531MS	SLOTTED HEX NUT	1
				36	529MS-2C	STOP COVER	1
				37	F0403SH	SOCKET HEAD BOLT 3/4" LONG	1
				38	F0600HFW	FLAT WASHER	2
				39	AM TAG #60	MESURING CUP SCALE	1
				40	512MS	DIVIDER CYLINDER 1"	1
				41	F0403FSH	FLAT SOCKET HEAD BOLT	4
				42	7370S	PIPE COUPLING	1
				43	724OS	STREET ELBOW, 90DEG	2
				44	722OS	MALE CONNECTOR - HOSE	1

INDIVIDUAL MEASURING CUP ASSEMBLIES

- AMS1 - FOR 1oz. TO 2oz. PIECES
- AMS2 - FOR 2oz. TO 4oz. PIECES
- AMS3 - FOR 4oz. TO 10 oz. PIECES
- AMS5 - FOR 10oz. TO 32oz. PIECES

NOTE:

PART NO. A501MS (COMPLETE STOP COVER ASSEMBLY AVAILABLE TO REPLACE OLD STYLE STOP COVERS).

SMALL CONVEYOR & DRIVE ASSEMBLY

ITEM	PART NO.	DESCRIPTION	QTY
1	BSC67	SMALL CONVEYOR FRAME	1
2	BSC3-4	CONVEYOR BELT	1
3	F0600NC	HEX NUT W/ RUBBER INSERT	2
4	BSC72	IDLER ROLLER SHAFT	1
5	F0600RW	RETAINING WASHER	2
6	641SC2	BALL BEARING	2
7	BSC66	IDLER ROLLER	1
8	F0401SS	SET SCREW	2
9	600SC	ROLLER SUPPORT	2
10	F0600NC	HEX NUT	6
11	F0600FW	FLAT WASHER	6
12	F0600LW	LOCK WASHER	6
13	F0604HH	BOLT	2
14	F0602HH	BOLT	4
15	F0408SD	STUD	4
16	F0400FW	FLAT WASHER	8
17	F0400NC	HEX NUT	8
18	F0400WN	WING NUT	7
19	F0400LW	LOCK WASHER	7
20	F0406RH	BOLT	3
21	BSC63	DOUGH GUIDE SUPPORT	1
22	BSC62	PRESSURE PLATE	1
23	BSC62-1	PRESSURE PLATE BRACKET	1
24	SS262	1/6 H.P. GEAR MOTOR	1
25	F0400KY	KEY	1
26	BSC73-1	SPUR GEAR 24T	1
27	F0800WF	FIBER WASHER	3
28	BSC68	DRIVE ROLLER ASSEMBLY	1
29	BSC70	DRIVE ROLLER SHAFT	1
30	BSC65	SMALL CONVEYOR MOUNTING ARM	1
31	BSC76	MOUNTING ARM PLATE	1
32	BSC74	INNER CABINET CONVEYOR SUPPORT BRACE	1

CONVEYOR ASSEMBLY

ITEM	PART NO.	DESCRIPTION	QTY
1	155RC	GUIDE BAR BELT TOP (SHORT)	1
2	156RC	GUIDE BAR BELT TOP (LONG)	1
3	641SC2	BEARING	2
4	103RC	SPACER	4
5	F9703TH	SCREW	7
6	105RC	ROLLER FRONT	1
7	106RC	SHAFT 5/8"	1
8	107RC	BALL BEARING (FRONT ROLLER)	2
9	F1000FWN	FLAT NYLON WASHER	4
10	F0502SS	SET SCREW	2
11	110RC	SUPPORT BEARING HOLDER	2
12	F1000NC	HEX NUT (BELT ADJUSTING)	4
13	112RC	BELT (LARGE CONVEYOR)	1
14	SS255	MOTOR 3/4 H.P. GEAR 100:1	1
15	F0600LW	LOCK WASHER	4
16	F0600NC	HEX NUT	4
17	K113LS	MOTOR SPROCKET 12T	1
18	118RC	KEY 3/16"	3
19	117RC	CHAIN	1
20	F0500FW (U.S.S.)	FLAT WASHER	4
21	F0606HH	BOLT	4
22	F0600FW	FLAT WASHER	4
23	F0812SDNP	STUD	2
24	F0800NC	HEX NUT	2
25	127RC	BALL BEARING (REAR ROLLER)	2
26	F0402HH	BOLT	8
27	F0400LW	LOCK WASHER	8
28	122RC	ROLLER SPROCKET 10T	1
29	126RC	FLANGE BEARING HOLDER	2
30	128RC	SHAFT 5/8"	1
31	129RC	ROLLER (COATED)	1
32	148RC	CONVEYOR FRAME	1
33	F1000HNC	HALF NUT	2
34	F0400FW	FLAT WASHER	1
35	F0400NC	NUT	1
36	133RC	SUPPORT BRACKET	1
37	152RC	PLASTIC STRIP	1
38	132RC	BELT SCRAPER	1
39	F9702TH	SCREW	4
40	F9700FW	FLAT WASHER	4
41	F9700NC	HEX NUT	4
42	141RC	CHAIN GUARD BRACKET (INNER)	1
43	143RC	CHAIN GUARD (OUTER)	1
44	F9701TH	SCREW	4
45	F0400NC	NUT	2
46	F0402TH	BOLT	2
47	F0502SS	SET SCREW	4
48	151RC	PINCH GUARD	1
49	154RC	CRUMB PAN SUPPORT	2
50	153RC	CRUMB PAN	1
51	F0404KY	KEY	1
52	157RC	CYCLE STOP MOUNT BRACKET	1
53	SS425	EMERGENCY STOP NAMEPLATE	1
54	SS185	STOP BUTTON, RED	1
55	SS336	ELECTRICAL ENCLOSURE	1
56	EL-1362	E-STOP CONTROL PLUG & CORD	1
57	EL-1425	90° CORD GRIP (.25" - .38")	1
58	EL-1396	E-STOP PLUG / CONNECTOR ADAPTER	1
59	400038	N.C. (NORMALLY CLOSED) CONTACT BLOCK	2

PRESSURE PLATE & MOUNTING FRAME

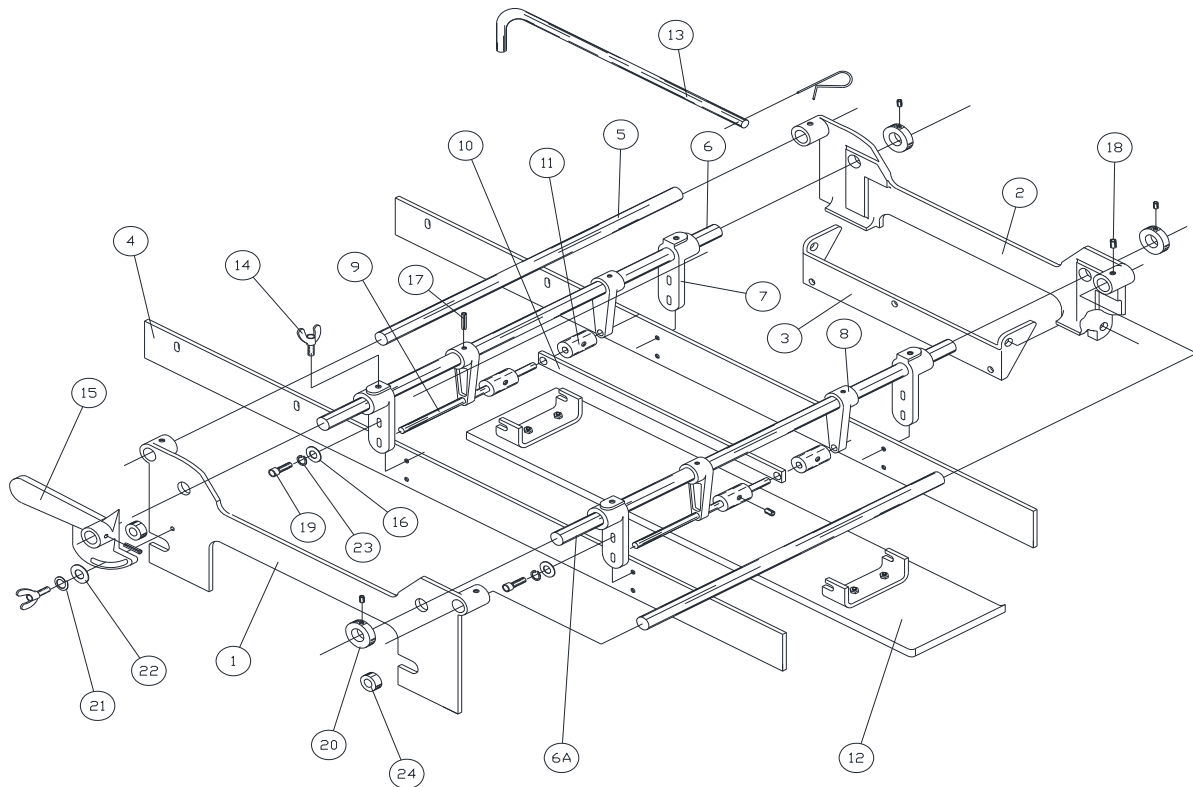

ITEM	PART NO.	DESCRIPTION	QTY
1	MPP1	SIDE PLATE LOCKING	1
2	MPP2	SIDE PLATE PIVOTING	1
3	MPP3	HINGE BRACKET	1
4	MPP4	PRESSURE PLATE GUIDE BAR	2
5	MPP5	SPACER BAR	2
6	MPP6-1	PIVOT BAR (REAR)	1
6A	MPP6-2	PIVOT BAR (FRONT)	1
7	MPP7	PRESSURE PLATE GUIDE BAR MOUNT	4
8	MPP8	PRESSURE PLATE PIVOT MOUNT	4
9	MPP9	PRESSURE PLATE MOUNTING ROD	2
10	MPP10	PIVOT SPACER BAR	1
11	MPP11	MOUNTING ROD SPACER	4
12	MPP12	PRESSURE PLATE - 6 INCH	1
13	MPP13	HINGE ROD	1
14	F0604WB	WING BOLT	5
15	MPP15	PIVOT LOCKING PLATE	1
16	F0400FW	FLAT WASHER	4
17	MPP17	ROLL PIN	8
18	F0502SS	SET SCREW	4
19	F0403SC	BOLT	8
20	MPP20	COLLAR LOCKING	3
21	F0600LW	LOCK WASHER	1
22	F0600FW	FLAT WASHER	1
23	F0400LW	LOCK WASHER	4
24	MPP25	SPACER	2

DOUGH CENTERING EXTENSION ARM

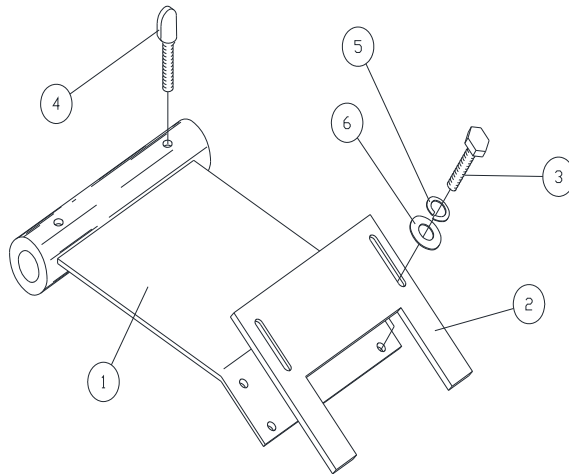

ITEM	PART NO.	DESCRIPTION	QTY
1	MCA1	PIVOT BRACKET	1
2	MCA2	CENTERING BLOCK	1
3	F0403HH	BOLT	4
4	F0402TS	THUMB SCREW	2
5	F0400LW	LOCK WASHER	4
6	F0400FW	FLAT WASHER	4

SECOND STAGE DIVIDER

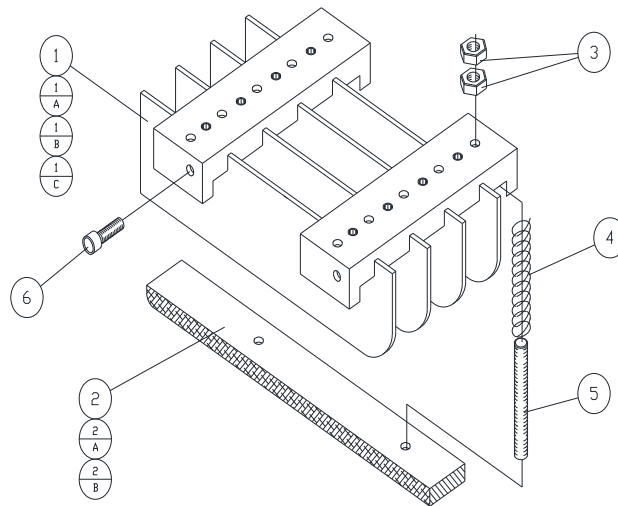

ITEM	PART NO.	DESCRIPTION	QTY
1	MSD	SPACER PLATE - 2 SPACE	1
1A	MSD1	SPACER PLATE - 3 SPACE	1
1B	MSD2	SPACER PLATE - 4 SPACE	1
1C	MSD3	SPACER PLATE - 5 SPACE	1
2	MSD4	PLASTIC PRESSURE PLATE - 3 SPACE	3
2A	MSD5	PLASTIC PRESSURE PLATE - 4 SPACE	4
2B	MSD6	PLASTIC PRESSURE PLATE - 5 SPACE	5
3	F0400NC	HEX NUT	AS REQ'D
4	MSD9	SPRING	AS REQ'D
5	F0412SD	STUD	AS REQ'D
6	F0404SH	BOLT	4

ELECTRICAL CONTROL PANEL COMPONENTS

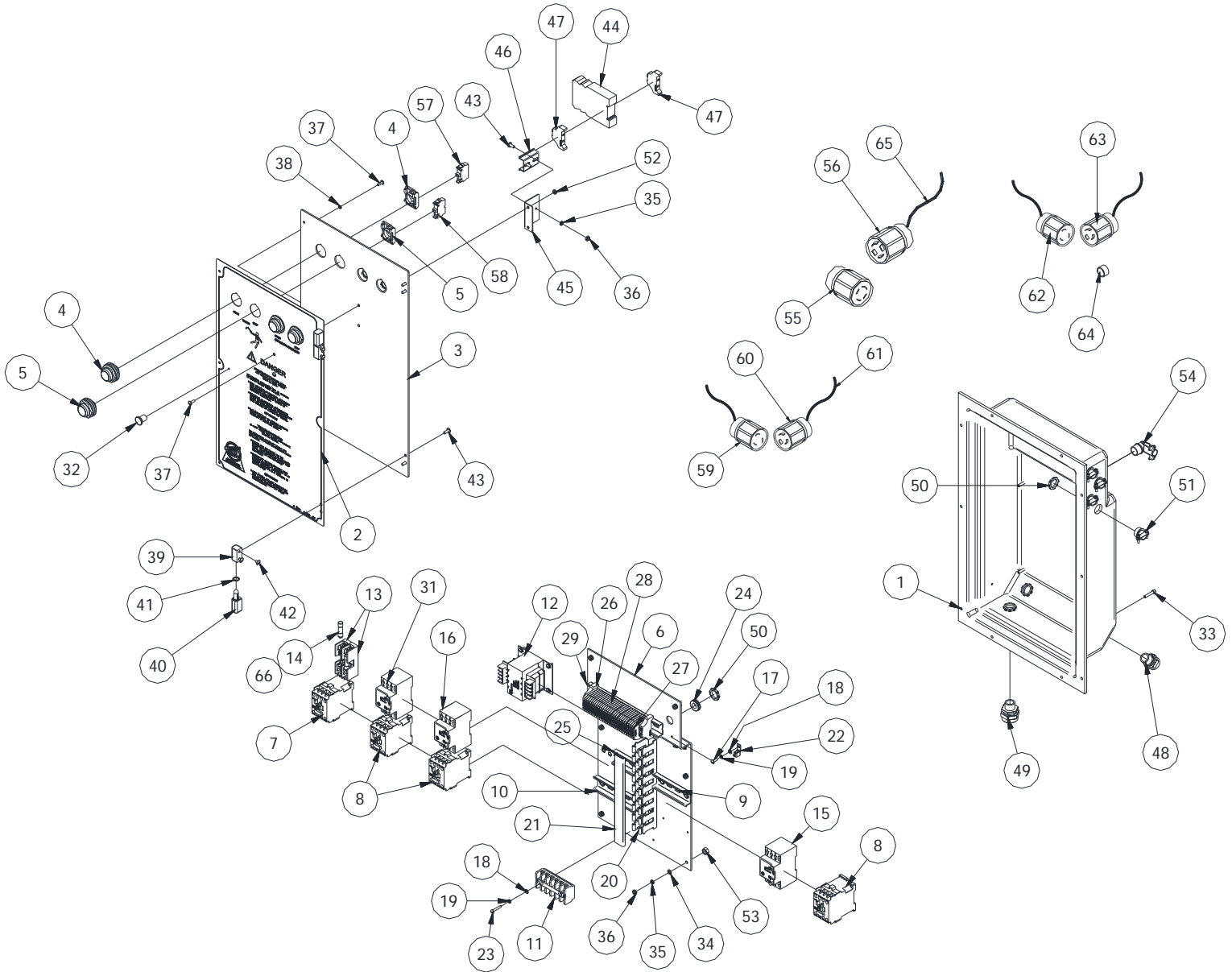

ELECTRICAL CONTROL PANEL PARTS LIST

ITEM	PART NO	DESCRIPTION	QTY
1	617CA6	ELECTRICAL ENCLOSURE	1
2	TAG #37	ELECTRICAL ENCLOSURE DOOR LABEL	1
3	11423	ELECTRICAL ENCLOSURE PANEL	1
4	SS184	PUSH BUTTON, GREEN	2
5	EL-0409	PUSH BUTTON, RED	2
6	SS268	ELECTRICAL SUB PANEL	1
7	EL-0935	IEC MOTOR CONTACTOR (16 AMP)	1
8	EL-0853	IEC MOTOR CONTACTOR (9 AMP)	3
9	EL-0975	DIN RAIL - 4" LONG	1
10	EL-0975	DIN RAIL - 5-7/8" LONG	1
11	SS143	6 POINT TERMINAL BLOCK	1
12	SS176	100VA TRANSFORMER	1
13	SS142	FUSE HOLDER	2
14	SS134	2 AMP FUSE (CLASS CC) – (208 – 230Vac MACHINES ONLY)	2
15	EL-0856	MANUAL MOTOR STARTER (6.3 - 10 AMPS)	1
16	EL-0855	MANUAL MOTOR STARTER (4.0 – 6.3 AMPS)	1
17	F9702TH	8-32 X 1/2" LONG TRUSS HEAD	18
18	F9700FW	FLAT WASHER #8	20
19	F9700LW	LOCK WASHER #8	20
20	SS181	WIRE DUCT - 1 X 2 X 9" LONG	1
21	SS182	WIRE DUCT COVER - 1" WIDE (9" LONG)	1
22	EL-1371	GROUNDING LUGS	2
23	F9704RH	SCREW (ROUND HEAD) 8-32 UNC X1	2
24	400071	PUSH-IN GROMMETS (1/2")	1
25	EL-0975	DIN RAIL - 5-7/8" LONG	1
26	EL-0396	TERMINAL BLOCK END ANCHOR	2
27	EL-0397	END BARRIER (GRAY)	4
28	EL-0395	TERMINAL BLOCK	29
29	EL-0975	DIN RAIL - 8.5" LONG	1
30	F9701.5TH	8-32 X 3/8" LONG TRUSS HEAD	2
31	EL-0858	MANUAL MOTOR STARTER (1.6 - 2.5 AMPS)	1
	*EL-0854	MANUAL MOTOR STARTER (2.5 – 4.0 AMPS) – (380-480Vac MACHINES ONLY)	
32	EL-0414	KNOB	1
33	F09904SH	SOCKET HEAD CAP SCREW (10-32 X 1" LONG)	6
34	F9900FW	FLAT WASHER, # 10	6
35	F9900LW	LOCK WASHER, #10	8
36	F9900MSN	10-32 MACHINE SCREW NUT	8
37	F9702TH	8-32 X 1/2" LONG TRUSS HEAD	3
38	F9700LW	LOCK WASHER #8	3
39	12099	KNUCKLE	2
40	12099	KNUCKLE FRONT MOUNT	2

*** SECOND PART USED SINGLE PHASE MACHINES**

NOTE:

GUARDS ARE INTERLOCKED, MACHINE WILL NOT OPERATE WITHOUT GUARDS IN PLACE.

NOTE:

ELECTRICAL PARTS STANDARD ON ALL MACHINES UNLESS SPECIFIED.

ELECTRICAL CONTROL PANEL PARTS LIST CONTINUED

ITEM	PART NO	DESCRIPTION	QTY
41	12099	WASHER	2
42	F9901TH	10-32 X 1/4" LONG TRUSS HEAD	4
43	F9902TH	10-32 X 1/2" LONG TRUSS HEAD	6
44	EL-1307	GUARDMASTER SAFETY RELAY	1
45	20452	SAFETY RELAY MOUNT BRACKET	1
46	EL-0975	DIN RAIL - 1-3/4" LONG	1
47	EL-0396	TERMINAL BLOCK END ANCHOR	2
48	SS275	1/2" CORD GRIP (.500 - .625)	1
49	SS276	1/2" CORD GRIP (.625 - .75)	1
50	SS101	1/2" CONDUIT FITTING LOCKNUT	7
51	SS100	3/8 CORD GRIP FITTING	4
52	F9700NC	NUT, COURSE 8-32 HEX	2
53	F0500NC	NUT COURSE, 5/16-18	6
54	SS103	FITTING, 90 DEGREE / 3/8" CORDGRIP	1
55	SS160	MAIN POWER CONNECTOR (208-230Vac) – STANDARD MACHINES	1
	*SS156	MAIN POWER CONNECTOR (208-230Vac SINGLE PHASE MACHINES ONLY)	
	*SS162	MAIN POWER CONNECTOR (380-480Vac THREE PHASE MACHINES ONLY)	
56	SS159	MAIN POWER PLUG	1
	*SS155	MAIN POWER PLUG (208-230Vac SINGLE PHASE MACHINES ONLY)	
	*SS161	MAIN POWER PLUG (380-480Vac THREE PHASE MACHINES ONLY)	
57	400039	N.O. CONTACT BLOCK	2
58	400038	N.C. CONTACT BLOCK	2
59	SS154	CONVEYOR MOTOR CONNECTOR	1
60	SS153	CONVEYOR MOTOR PLUG	1
61	SS221	16/3 CABLE (CONVEYOR MOTOR)	FT.
62	EL-1363	E-STOP CONTROL PLUG (FEMALE)	1
63	EL-1362	E-STOP CONTROL PLUG (MALE)	1
64	EL-1396	E-STOP PLUG / CONNECTOR ADAPTER	1
65	SS223	12/4 MAIN POWER CORD	12
	*SS222	12/3 POWER CORD (208-230VAC SINGLE PHASE MACHINES ONLY)	
66	*SS134	1 AMP FUSE (CLASS CC) – (380-480Vac MACHINES ONLY) – NOT SHOWN	2
67	*EL-0452	TRANSFORMER – 2KVA – LOCATED INSIDE MACHINE CABINET (380-480VAC MACHINES ONLY) – NOT SHOWN	1
68	*SS137	10 AMP FUSE (CLASS CC) – (380Vac MACHINES ONLY) – NOT SHOWN	2
69	*SS136	8 AMP FUSE (CLASS CC) – (480Vac MACHINES ONLY) – NOT SHOWN	2

* NOT STANDARD PARTS

OILING SYSTEM

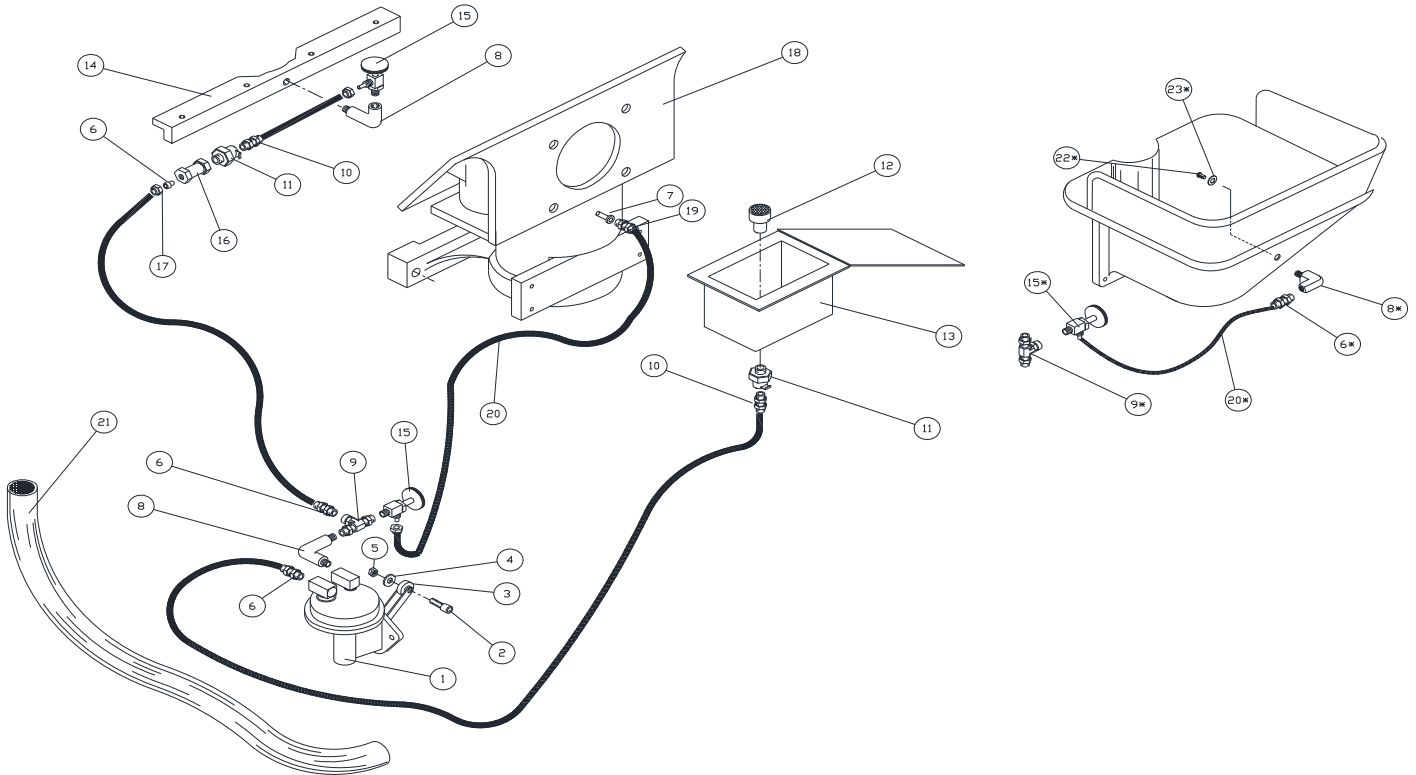

ITEM	PART NO.	DESCRIPTION	QTY
1	716OS	OIL PUMP	1
2	F0403SH	BOLT	1
3	714OS	PUMP ROLLER BEARING	1
4	F0400LW	LOCK WASHER	1
5	F0400NC	HEX NUT	1
6	722OS	MALE CONNECTOR	3
7	728OS	BRASS INSERT	1
8	724OS	STREET ELBOW 90°	2
9	725OS	STREET "T"	1
10	726OS	QUICK CONNECT, MALE	2
11	727OS	QUICK CONNECT, FEMALE	2
12	713OS	STRAINER W/ INSERT - FILTER ADAPTER	1
13	604CA	OIL BOX	1
14	21640	GIB BAR	1
15	14393	VALVE	2
16	103-B-OZ	BRASS COUPLING	1
17	709OS	PLASTIC FERRULES	10
18	AS0107CD	CYLINDER	1
19	708OS	MALE CHECK VALVE	1
20	710OS	1/4" OIL SYSTEM TUBING 12 FT.	12 FT.
21	711OS	1/2" OIL DRAIN TUBING 4 FT.	4 FT.
22	741OS	PLUG	1
23	F0400FW	STAINLESS STEEL FLAT WASHER	1

#14 – SEE PAGES 30 & 31 FOR DETAILED GIB BAR COMPONENTS

* INDICATES PARTS AVAILABLE WITH PART NO.
 445CDE EXTENDED HOPPER (ONLY)

**NOTE:
 OPTIONAL EQUIPMENT

TROUBLESHOOTING

DANGER:
 ALWAYS DISCONNECT ELECTRICAL POWER SOURCE
 WHEN MAINTAINING OR REPAIRING THIS MACHINE...

NOTE:
 GUARDS ARE INTERLOCKED, MACHINE
 WILL NOT OPERATE WITHOUT GUARDS
 IN PLACE.

THE OPERATION OF THE SCALE - O - MATIC DEPENDS ON VACUUM, FOR TOP PERFORMANCE. THEREFORE CAN ONLY BE REALIZED IF ALL SEAL POINTS ARE IN PROPER ADJUSTMENT. THE FOLLOWING PLACES FOR POSSIBLE LOSS OF VACUUM ARE TO BE CHECKED:

1. PART NO. **S0113CD** GEAR
 MAKE SURE MACHINE IS RUNNING IN THE RIGHT DIRECTION. SEE ARROW ON GEAR.
 GEAR MUST TURN CLOCKWISE.
2. PART NO. **402CD**-NEOPRENE "O" RING
 CHECK FOR LOSS OF COMPRESSIBILITY.
3. PART NO. **506MS**-SLIDE PRESSURE STRIPS-POLYETHYLENE
 CHECK FOR WEAR.
4. PART NO. **521MS** SLIDE WEAR STRIP-NYLON
 CHECK FOR WEAR.
5. PART NO. **504MS** GIB SCREWS
 CHECK FOR SNUGNESS
6. PART NO. **323PY** PISTON RING
 CHECK FOR WEAR-REPLACE IF WORN OR SCORED.
7. PART NO. **503MS** MEASURING CUP PLUNGER ROD GUIDE CHECK FOR WEAR AND SMOOTHNESS OF OPERATION. IF WORN PART NO. 513MS WILL BIND OR STICK.
8. PART NO. **513MS** PLUNGER
 CHECK FOR CIRCUMFERENCE WEAR, REPLACE IF DOUGHS BY-PASS INTO SPRING SECTION.
9. PART NO. **434CD** V-BELT DRIVE
 KEEP BELT TIGHT TO AVOID SLIPPAGE.
10. PART NO. **401CD** SEAL SCRAPER RING
 CHECK FOR WEAR AND FOR STRAIGHTNESS.
11. PART NO. **S0113CD** GEAR
 CLEAN CAM TRACK OCCASIONALLY. OBSERVE IF PART NO. **448CD** (CAM TRACK SHOE)
 IS WORN. ALSO CHECK FOR WEAR ON GEAR CAM TRACK.
12. PART NO. **21640 / 21641** GIB BAR
 CHECK GIB BARS FOR WEAR AND EXCESSIVE PLAY BETWEEN DIVIDER SLIDE.

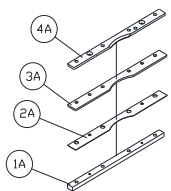
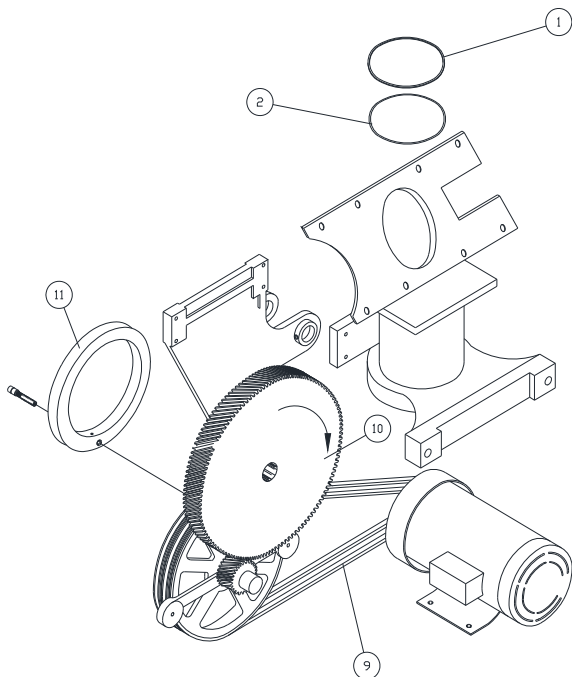
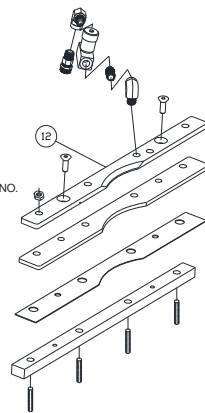
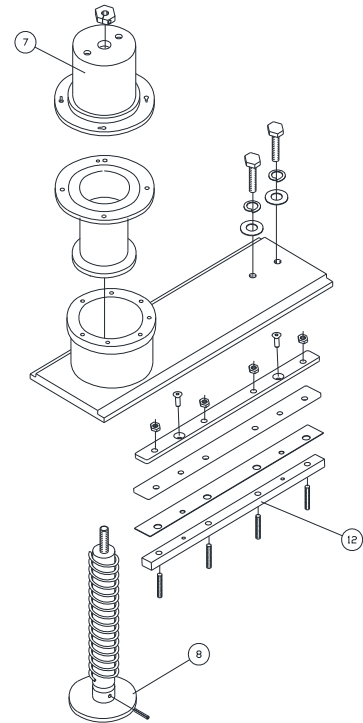

ASSEMBLY INSTRUCTIONS:

- 1A. INSERT SPACER BAR OVER GIB BAR BOLTS FIRST. (507MS)
- 2A. PLACE WEAR STRIP LINER (1/32" X 13" LG.) OVER SPACER BAR. (521MS-T)
- 3A. PLACE PLASTIC WEAR STRIP (1/4" X 13" LG.) OVER LINER. (506MS-T)
- 4A. NOW PLACE TOP GIB BAR OVER PLASTIC WEAR STRIP AND SECURE WITH HEX BOLTS. (505MS)

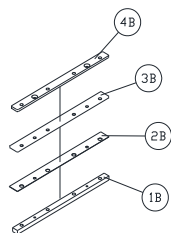
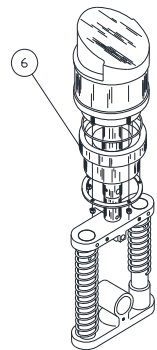

ASSEMBLY INSTRUCTIONS:

- 1B. INSERT SPACER BAR OVER GIB BAR BOLTS FIRST. (507MS)
- 2B. PLACE WEAR STRIP LINER (1/32" X 13" LG.) OVER SPACER BAR. (521MS-B)
- 3B. PLACE PLASTIC WEAR STRIP (1/4" X 13" LG.) OVER LINER. (506MS-B)
- 4B. NOW PLACE TOP GIB BAR OVER PLASTIC WEAR STRIP AND SECURE WITH HEX BOLTS. (520MS)

ELECTRICAL (SCHEMATIC) SINGLE PHASE / 208 - 230 VOLT

— SHEET 1 —

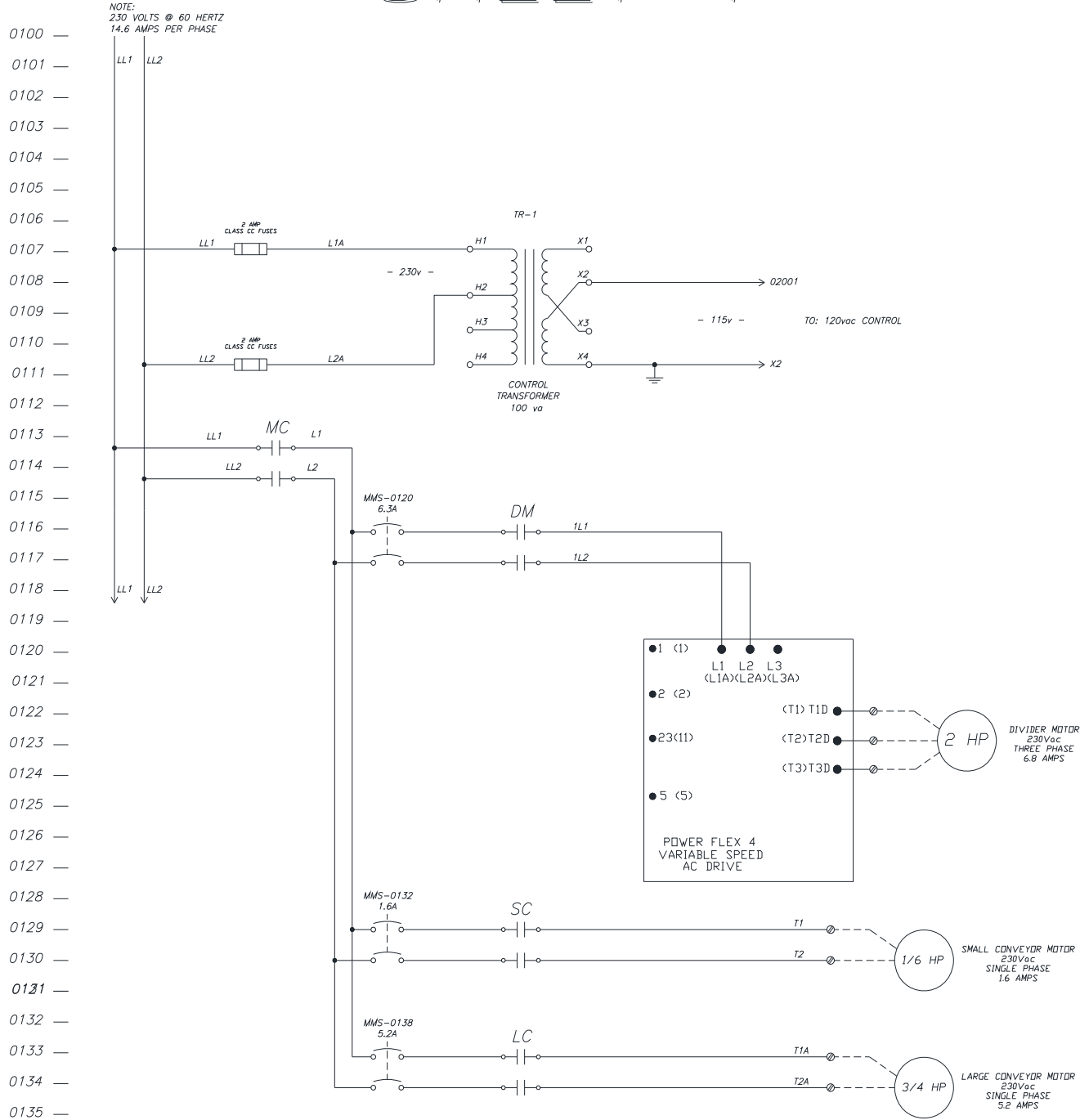

ELECTRICAL (SCHEMATIC) THREE PHASE / 208-230 VOLT

— SHEET 1 —

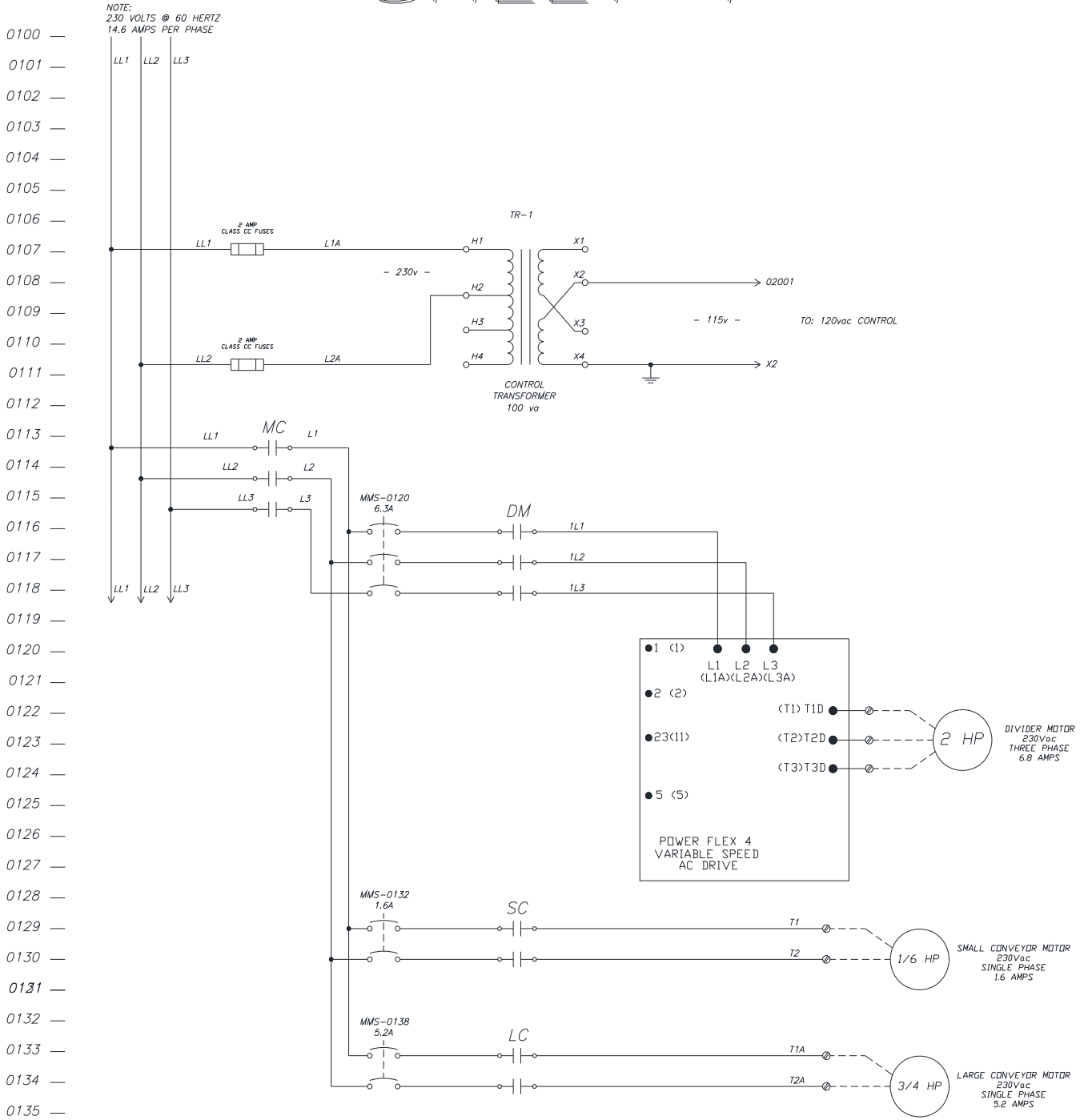

ELECTRICAL (SCHEMATIC) THREE PHASE / 380 VOLT

— SHEET 1 —

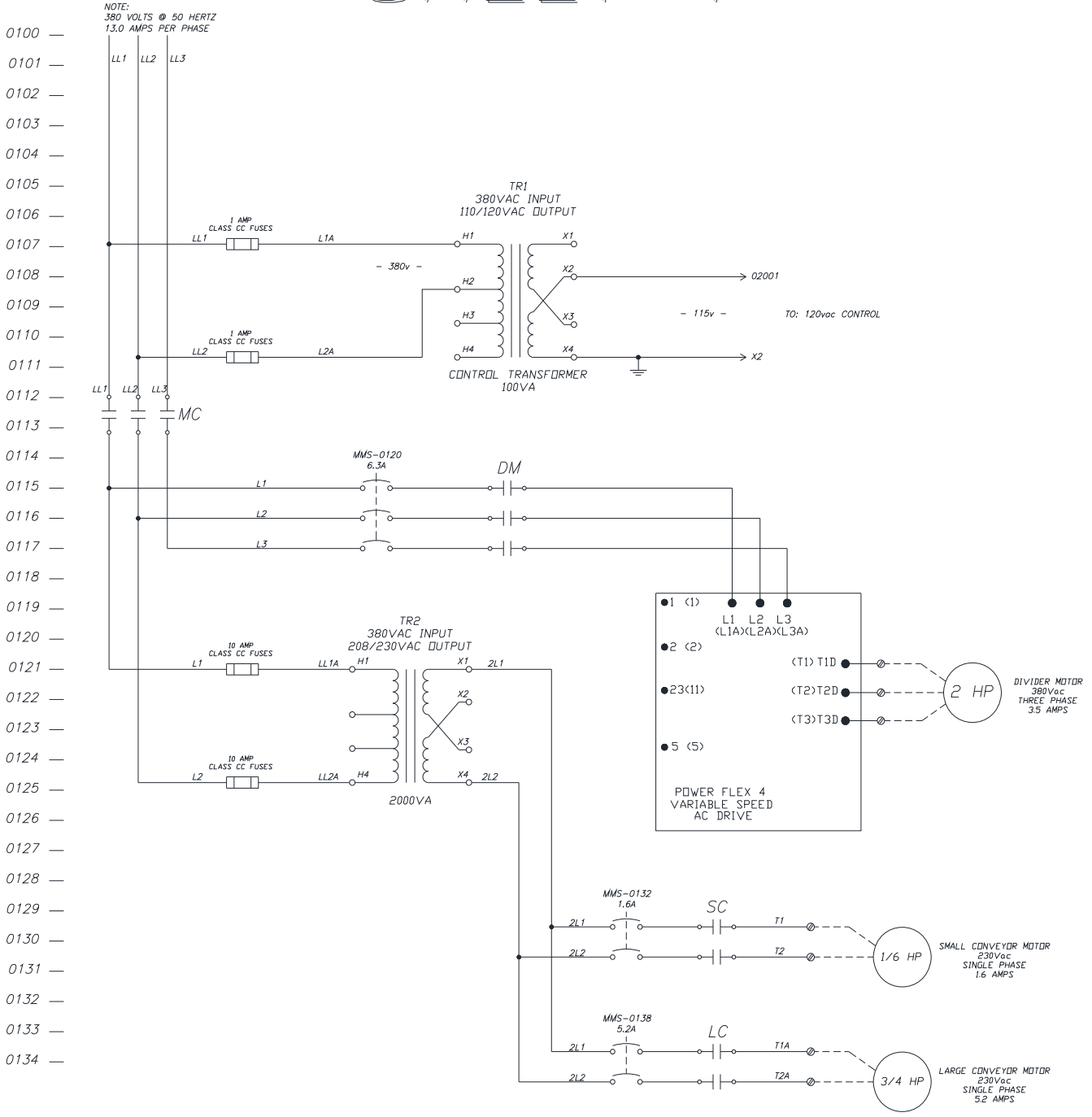

ELECTRICAL (SCHEMATIC) THREE PHASE / 480 VOLT

SHEET 1

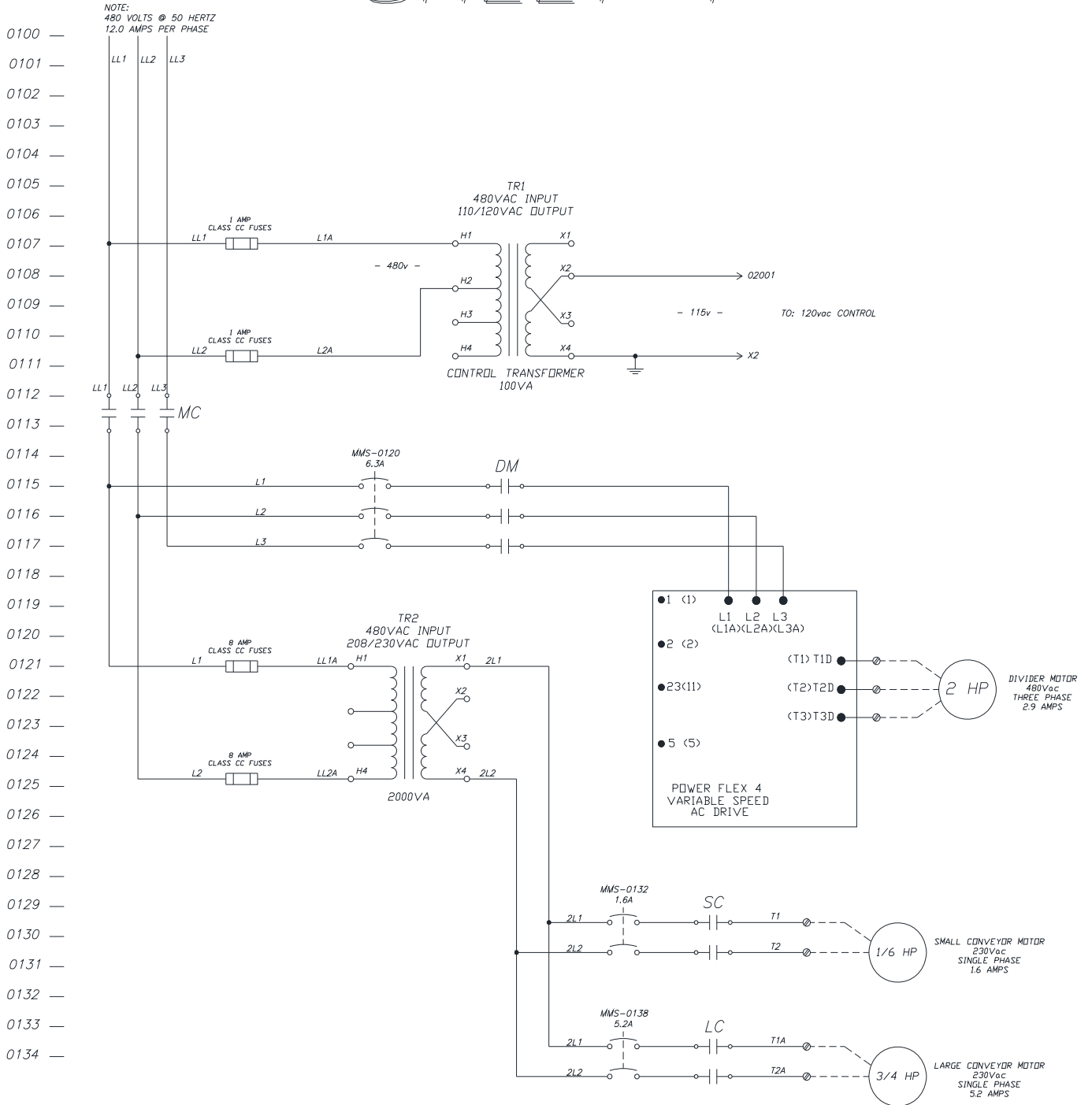

ORDERING REPLACEMENT PARTS

IMPORTANT:

ONLY USE FACTORY SUPPLIED REPLACEMENT PARTS TO MAINTAIN MACHINE SAFETY, PERFORMANCE AND SANITARY CONDITIONS.

USE OF NON-APPROVED PARTS MAY VOID MANUFACTURERS WARRANTY.

TO ORDER REPLACEMENT PARTS ALWAYS:

- 1) CHECK THE MACHINE TOP IDENTIFY MISSING, DAMAGED OR NON-FUNCTIONAL PARTS INCLUDING GUARDS, WARNING LABELS AND INSTRUCTIONS.
- 2) COMPARE THE LIST WITH THE PARTS DIAGRAMS SUPPLIED.
- 3) RECORD THE COMPLETE MODEL AND SERIAL NUMBER OF THE UNIT.
- 4) CALL A.M. MANUFACTURING (800) 342-6744 AND PROVIDE ALL INFORMATION NOTED ABOVE TO EXPEDITE ORDER PROCESSING AND HELP REDUCE SHIPPING COST.
- 5) PROVIDE COMPLETE DETAILS FOR (SHIP TO) AND (BILL TO) INFORMATION. TO ASSIST PROMPT DELIVERY, SPECIFY TYPE OF CARRIER PREFERRED IN SHIPMENT.
- 6) MOST MAJOR CREDIT CARDS ACCEPTED.

