

# THE ATWOOD SCALE - O - MATIC MULTI DOUGH DIVIDER

## MODEL: S500

### OPERATIONS AND SAFETY MANUAL

INCLUDING PARTS CATALOG  
AND MAINTENANCE INSTRUCTIONS

MODEL No. \_\_\_\_\_

SERIAL No. \_\_\_\_\_



#### **CAUTION:**

DO NOT OPERATE, CLEAN OR SERVICE THIS MACHINE BEFORE YOU READ THIS MANUAL, AND ARE FAMILIAR WITH THE SAFETY INSTRUCTIONS IN THIS MANUAL AND THOSE ON THE LABELS ON THE MACHINE. KEEP THIS MANUAL AND OTHER MATERIALS DELIVERED WITH THE MACHINE, ACCESSIBLE TO THE OPERATORS FOR EASY REFERENCE DURING USE.

THE ENTIRE CONTENTS OF THIS PUBLICATION ARE COPY WRITTEN AND ALL RIGHTS ARE RESERVED. REPRODUCTION IN WHOLE OR IN PART IS PROHIBITED WITHOUT WRITTEN PERMISSION OF A.M. MFG. INC.

IF YOU SHOULD HAVE ANY (?)  
QUESTIONS ABOUT GUARDS OR  
PLACEMENT CALL (708) 841-0959.

THIS CATALOG BECOMES OBSOLETE ON 12/31/00.  
UPDATED CATALOGS ARE AVAILABLE DIRECTLY  
FROM A.M. MFG. INC.



## **MANUFACTURING COMPANY**

DIVISION OF THE ATWOOD CORPORATION  
14151 IRVING AVENUE DOLTON, ILLINOIS 60419  
(773) 703-5117 (708) 841-0959 (800) 342-6744 FAX: (708) 841-0975 [www.ammfg.com](http://www.ammfg.com)

# OWNERS RESPONSIBILITY

**NOTE:**

**THE PARTS AND EQUIPMENT DESCRIBED IN THIS MANUAL MAY BE COVERED BY ONE OR MORE U.S. AND FOREIGN PENDING PATENTS.**



TO MAINTAIN MACHINE AND USER SAFETY, THE RESPONSIBILITY OF THE OWNER IS TO READ AND FOLLOW THESE INSTRUCTIONS AND TO ENSURE THAT ALL OPERATORS UNDERSTAND AND FOLLOW THESE AND OTHER SAFETY INSTRUCTIONS IN THIS MANUAL.

- FOLLOW ALL INSTALLATION INSTRUCTIONS.
- MAKE SURE INSTALLATION CONFORMS TO ALL APPLICABLE LOCAL, STATE, AND FEDERAL CODES, RULES AND REGULATIONS SUCH AS STATE AND FEDERAL OSHA REGULATIONS AND ELECTRICAL CODES.
- CAREFULLY CHECK THE UNIT FOR CORRECT INITIAL FUNCTION.
- READ AND FOLLOW THE SAFETY INSTRUCTIONS. KEEP THEM READILY AVAILABLE FOR MACHINE OPERATORS.
- MAKE CERTAIN ALL OPERATORS ARE PROPERLY TRAINED, KNOW HOW TO SAFELY AND CORRECTLY OPERATE THE UNIT AND ARE PROPERLY SUPERVISED.
- ALLOW UNIT OPERATION ONLY WITH ALL PARTS INCLUDING SAFETY EQUIPMENT, IN PLACE AND OPERATING SAFELY.
- CAREFULLY INSPECT THE UNIT ON A REGULAR BASIS AND PERFORM ALL MAINTENANCE AS REQUIRED.
- SERVICE AND MAINTAIN THE UNIT ONLY WITH AUTHORIZED OR APPROVED REPLACEMENT PARTS.
- KEEP ALL INSTRUCTIONS PERMANENTLY WITH THE UNIT ALONG WITH ALL DECALS AND WARNING LABELS ON THE UNIT CLEAN AND VISIBLE.

# TABLE OF CONTENTS

	<u>PAGE</u>
OWNERS RESPONSIBILITIES .....	INSIDE COVER
INTRODUCTION & SPECIFICATIONS & INSTALLATION .....	2
SAFETY SIGNAL WORDS .....	3
LOCATION OF WARNING LABELS .....	4
REPRODUCTION OF WARNING LABELS .....	5
GENERAL SAFETY INFORMATION .....	6
OPERATING INSTRUCTIONS .....	7
GUIDE TO CLEANING .....	8-11
GUIDE TO MAINTENANCE .....	12-13
 <b><u>PARTS CATALOG</u></b>	
CABINET ASSEMBLY .....	14-15
CYLINDER AND DRIVE ASSEMBLY .....	16-17
PISTON AND CONNECTING ROD ASSEMBLY .....	18-19
MEASURING CUP AND DIVIDER SLIDE ASSEMBLY .....	20-21
SMALL DRIVE CONVEYOR ASSEMBLY .....	22-23
CONVEYOR ASSEMBLY .....	24-25
PRESSURE PLATE & MOUNTING FRAME ASSEMBLY .....	26
DOUGH CENTERING EXTENSION ARM / SECOND STAGE DIVIDER .....	27
ELECTRICAL / SENSOR SYSTEM .....	28-29
OILING SYSTEM .....	30
TROUBLESHOOTING .....	31
ELETRICAL SCHEMATIC (3-PHASE 115 / 230 VOLT) .....	32
ELETRICAL HARDWIRE (3-PHASE 115 / 230 VOLT) .....	33
ELETRICAL SCHEMATIC(3-PHASE 208 VOLT) .....	34
ELECTRICAL HARDWIRE (3-PHASE 208 VOLT) .....	35
ORDERING REPLACEMENT PARTS .....	36
NOTES .....	37

## IMPORTANT:

A.M. MANUFACTURING Co. RESERVES THE RIGHT TO MAKE CHANGES IN DESIGN, SPECIFICATIONS OR MANUFACTURING. TO IMPROVE THEIR PRODUCTS WITHOUT NOTICE AND WITHOUT OBLIGATION TO CHANGE OR IMPROVE PREVIOUSLY BUILT PRODUCTS INCLUDING MANUALS AND CATALOGS.

ONLY USE FACTORY SUPPLIED REPLACEMENT PARTS TO MAINTAIN MACHINE SAFETY, PERFORMANCE AND SANITARY CONDITIONS. USE OF NON-APPROVED PARTS MAY VOID MANUFACTURERS WARRANTY.

KNOW YOUR UNIT. COMPARE DIAGRAMS IN THIS MANUAL WITH THE UNIT BEFORE STARTING SERVICE, TO OBTAIN MAXIMUM SAFETY AND PERFORMANCE.

TO ORDER REPLACEMENT PARTS:  
TURN TO PAGE 36 OF THIS MANUAL.



## WARNING:

THIS MANUAL CONTAINS CRITICAL SAFETY INSTRUCTIONS. READ AND FOLLOW THEM CAREFULLY. FAILURE TO FOLLOW WARNING AND INSTRUCTIONS MAY LEAD TO SERIOUS PERSONAL INJURY. THE OWNER IS RESPONSIBLE FOR MAINTAINING THE UNIT, ITS INSTRUCTIONS AND DECALS FOR OPERATION REFERENCE. FOR ADDITIONAL COPIES CONTACT A.M. MANUFACTURING: (800)342-6744.

# OPERATIONS AND SAFETY MANUAL

## INCLUDING PARTS CATALOG

**READ AND FAMILIARIZE YOURSELF WITH THIS MANUAL BEFORE OPERATING THIS MACHINE  
FOLLOW INSTRUCTIONS DURING USE**

## INTRODUCTION

THE ATWOOD MULTI DOUGH DIVIDER IS DESIGNED TO ACCURATELY DIVIDE DOUGH IN THE 1 TO 3 oz. RANGE WHERE PRODUCTION REQUIREMENTS CALL FOR 6,000 TO 10,000 DOUGH PIECES PER HOUR. UTILIZING "THE FAMOUS SCALE - O - MATIC DOUGH DIVIDER, A LARGER PIECE IS DIVIDED THEN CUT INTO 3, 4, OR 5 EQUAL PIECES. THIS UNIT IS IDEAL FOR DIVIDING A WIDE VARIETY OF PRODUCTS, ESPECIALLY TORTILLAS AND PITA BREAD. STUDY THIS OPERATION AND SAFETY MANUAL FOR FULL BENEFITS.



### CAUTION:

ALL OPERATORS MUST BE FULLY TRAINED AND INSTRUCTED IN SAFETY PROCEDURES BEFORE BEGINNING PRODUCTION.

## SPECIFICATIONS

HOPPER CAPACITY	100 lbs.
HEIGHT	58"
LENGTH	82"
WIDTH	26"
SHIPPING WEIGHT	1000 lbs.
DIVIDER MOTOR	3 PHASE, 2 H.P. MOTOR
CONVEYOR MOTOR	1 PHASE, 3/4 H.P. MOTOR
SMALL CONVEYOR	1 PHASE, 1/6 H.P. MOTOR
RECIPROCAL MOTION	
MECHANICAL DIVIDER	
AUTOMATIC SPRING PRESSURE, SELF ADJUSTABLE	
EXTRA DIVIDER CUPS AVAILABLE AS OPTIONAL EQUIPMENT.	<u>OPTIONAL EQUIPMENT</u>
NO. 2 DIVIDING CUP 2 TO 4 oz.	EXTENDED HOPPER (140 lbs. CAPACITY)
NO. 3 DIVIDING CUP 4 TO 10 oz.	COMPUTERIZED VARIABLE SPEED
	USDA/FDA APPROVED CONVEYOR BELT
	EXTERNAL OIL TANK
VOLTAGES: 3 PHASE, 208/230 VOLT	3 CUTTER (2 TO 3 oz.)
SINGLE PHASE, 208/230 VOLT (OPTIONAL)	4 CUTTER (1 1/4 TO 2 oz.)
	5 CUTTER (3/4 TO 1 1/4 oz.)

## INSTALLATION INSTRUCTIONS

### LOCATION:

SELECT LOCATION CAREFULLY. THE AREA SHOULD PROVIDE THE OPERATOR WITH ENOUGH SPACE TO USE THE EQUIPMENT IN A SAFE MANNER. THE FLOOR AREA SELECTED SHOULD BE EASY TO CLEAN AND SHOULD BE FREE OF OIL, GREASE, ETC. AVOID AREAS WHERE BYSTANDERS AND CUSTOMERS MAY BE PRESENT.



### CAUTION

PROPER UNIT INSTALLATION IS NECESSARY FOR SAFE AND EFFICIENT OPERATION. PROPER INSTALLATION ALSO HELPS PROTECT THE UNIT FROM DAMAGE AND MAKES SERVICE EASIER.

# SAFETY

THIS MACHINE IS DESIGNED TO PROVIDE FOR SAFE OPERATION IF NORMAL OPERATING PROCEDURES AND SAFETY MESSAGES LOCATED ON THE MACHINE AND IN THIS MANUAL ARE FOLLOWED.



THIS IS A SAFETY ALERT SYMBOL. YOU WILL FIND IT ON VARIOUS SAFETY LABELS ON THE MACHINE AND IT WILL ALSO APPEAR IN THIS MANUAL WHEREVER SAFETY MESSAGES ARE GIVEN.

GET FAMILIAR WITH SIGNAL WORDS:

## CAUTION, WARNING & DANGER

### **CAUTION:**

INDICATES A POTENTIALLY HAZARDOUS SITUATION WHICH, IF NOT AVOIDED, MAY RESULT IN MINOR OR MODERATE INJURY. IT MAY ALSO BE USED TO ALERT AGAINST UNSAFE PRACTICES.

### **WARNING:**

INDICATES A POTENTIALLY HAZARDOUS SITUATION WHICH, IF NOT AVOIDED, COULD RESULT IN DEATH OR SERIOUS INJURY.

### **DANGER:**

INDICATES AN IMMINENTLY HAZARDOUS SITUATION WHICH, IF NOT AVOIDED, WILL RESULT IN DEATH OR SERIOUS INJURY. THIS SIGNAL WORD IS TO BE LIMITED TO THE MOST EXTREME SITUATIONS.

### **NOTE:**

A NOTE PROVIDES KEY INFORMATION TO MAKE PROCEDURES EASIER AND CLEARER.

# TYPICAL WARNING LABEL LOCATIONS

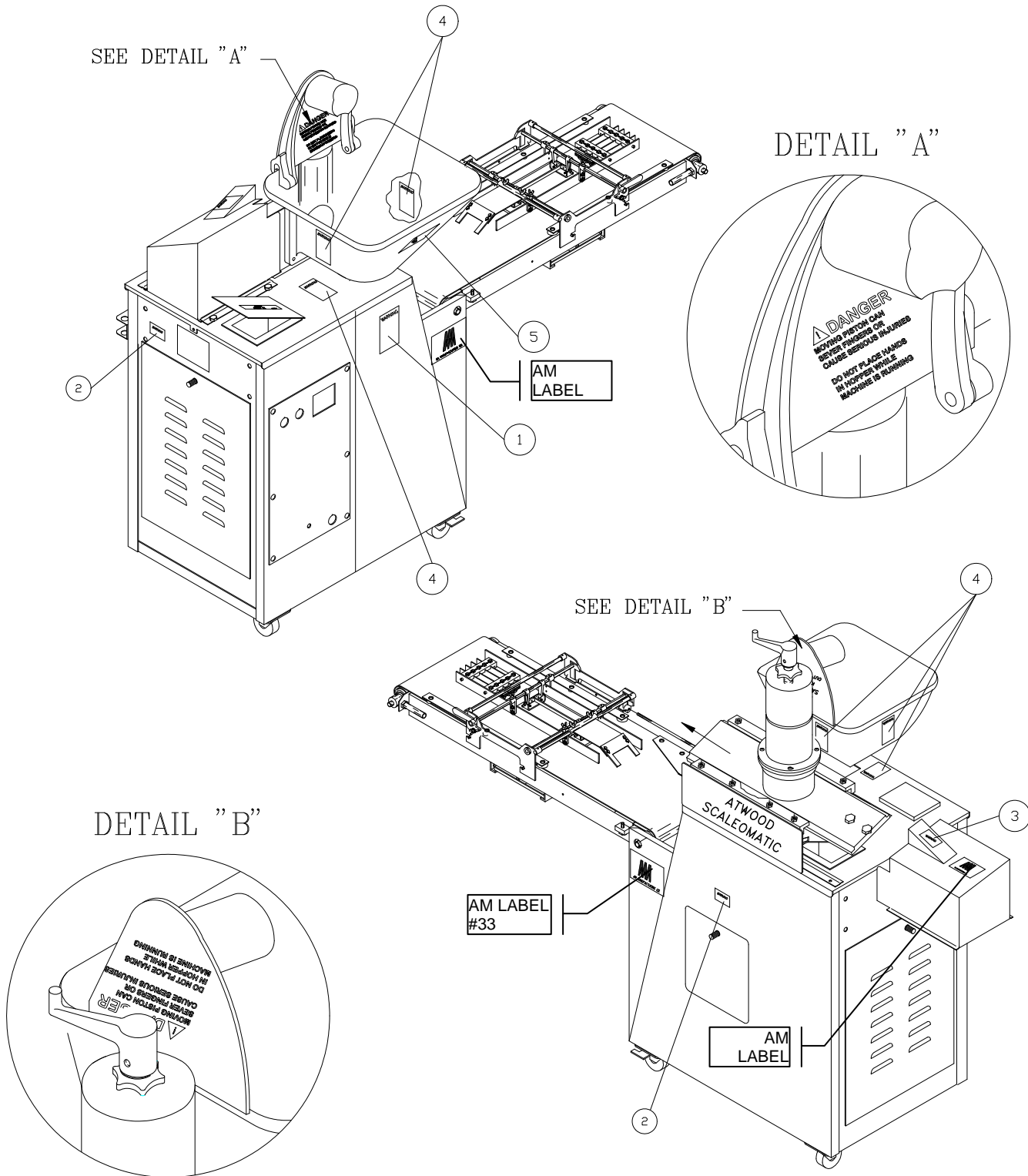

# WARNING LABELS

## TYPICALLY FOUND ON THE SCALE-O-MATIC MODEL:

PART NO. AM MFG. # 21

**IMPORTANT SAFETY INFORMATION**

©1992 AM MFG #21

- DO NOT OPERATE THIS MACHINE BEFORE YOU HAVE READ AND UNDERSTAND THE OPERATIONS AND SAFETY MANUAL.
- NEVER LEAVE THIS MACHINE RUNNING UNATTENDED.
- NEVER OPERATE THIS MACHINE IF SAFETY GUARDS ARE NOT IN PLACE.
- NEVER REMOVE ANY SAFETY GUARDS AND NEVER MAKE ANY OTHER SAFETY EQUIPMENT INOPERATIVE.
- NEVER OPERATE THIS MACHINE IF YOU HAVE NOT BEEN TRAINED.
- NEVER OPERATE THIS MACHINE IF YOU ARE TIRED, ILL, OR IF YOU ARE ON MEDICATION THAT MAKES YOU TIRED, OR IF YOU ARE UNDER THE INFLUENCE OF ALCOHOL OR DRUGS.
- WEAR TIGHT FITTING CLOTHES AND MAKE SURE THAT LONG HAIR AND JEWELRY OR OTHER LOOSE PERSONAL ITEMS DO NOT GET CAUGHT IN THE MACHINE.
- MAKE SURE YOU CAN EASILY REACH THE CONTROLS.
- ALWAYS DISCONNECT THE MAIN ELECTRICAL POWER SOURCE BEFORE YOU CLEAN, MAINTAIN, OR SERVICE THIS MACHINE.
- IF YOU HAVE ANY QUESTIONS ABOUT SAFETY, TALK TO YOUR SUPERVISOR OR CALL

**A.M. MANUFACTURING**  
 TOLL FREE 1-(800)-342-6744

1 MAIN FRAME (RIGHT SIDE OF CONTROL PANEL)

PART NO. AM MFG. # 10

**!**

**DANGER**

HAZARDOUS VOLTAGE,  
WILL SHOCK, BURN,  
OR CAUSE DEATH

DISCONNECT ALL ELECTRICAL POWER BEFORE REMOVING PROTECTIVE SHIELDS OR TOUCHING ELECTRICAL EQUIPMENT WHILE SERVICING OR CLEANING THIS MACHINE...

©1992 AM MFG #10

2 - REAR PANEL OF DIVIDER CABINET  
 - CABINET (PISTON ENTRY SIDE)

**NOTE:**

MACHINE DESIGN AND SPECIFICATIONS MAY VARY. ACTUAL LABEL DESIGN AND PLACEMENT SUBJECT TO CHANGE WITHOUT NOTICE AND MAY VARY FROM THIS ILLUSTRATION.

PART NO. AM MFG. # 11

**! WARNING**

ALL GUARDS AND SAFETY SHIELDS MUST BE IN PLACE BEFORE STARTING MACHINE. NEVER OPERATE THIS MACHINE WITHOUT SAFETY SHIELDS IN PLACE. DO NOT CHANGE THIS MACHINE IN ANY WAY TO INTERFERE WITH OR ELIMINATE THESE ESSENTIAL SAFETY FEATURES.

© 1992 AM MFG. #11

3 - ROCKER ARM COVER  
 - IDLER PULLEY GUARD  
 - CHAIN GUARD

PART NO. AM MFG. # 27

**DANGER**

1993 AM MFG. #27

MOVING PISTON WILL CUT OFF FINGERS OR CAUSE SERIOUS INJURIES.

DO NOT PLACE HANDS IN HOPPER WHILE MACHINE IS RUNNING.

? ABOUT GUARDS AND GUARDING CALL (708-841-0959)

4 - RIGHT & LEFT SIDES OF DOUGH HOPPER

**!**

**DANGER**

MOVING PISTON CAN SEVER FINGERS OR CAUSE SERIOUS INJURIES

DO NOT PLACE HANDS IN HOPPER WHILE MACHINE IS RUNNING

-FRONT OF HOPPER  
 -FRONT & BACK OF HOPPER COVER



**CAUTION:**

IF ANY SAFETY LABELS ARE MISSING, THEY **MUST BE REPLACED!** CONTACT YOUR DEALER OR A.M. MFG. FOR REPLACEMENT.

# SAFETY RULES



## IMPORTANT:

READ AND FOLLOW THESE SAFETY RULES. THEY ARE FOR YOUR PROTECTION AND THE PROTECTION OF THOSE WORKING WITH YOU.

- DO NOT OPERATE THIS MACHINE BEFORE YOU READ AND UNDERSTAND THE OPERATIONS AND SAFETY MANUAL.
- FOLLOW ALL INSTRUCTIONS DURING USE OF THIS MACHINE.
- LEAVE ALL GUARDS IN PLACE. INSTALL ALL GUARDS IF THEY WERE REMOVED FOR CLEANING, MAINTENANCE, REPAIR, OR OTHER REASONS.
- NEVER OPERATE THE MACHINE IF YOU HAVE NOT BEEN TRAINED TO OPERATE THE MACHINE PROPERLY.
- NEVER OPERATE THE MACHINE IF YOU ARE TIRED, ILL, ON MEDICATION, OR UNDER THE INFLUENCE OF ALCOHOL OR DRUGS.
- WEAR TIGHT FITTING CLOTHES. MAKE SURE THAT LONG HAIR, JEWELRY, OR LOOSE PERSONAL ITEMS ARE SECURED SO THEY CANNOT GET CAUGHT IN THE MACHINE. THIS CAN LEAD TO SERIOUS INJURIES.
- MAKE SURE YOU CAN EASILY REACH ALL CONTROLS. IF NOT, A STABLE AND SAFE ELEVATED PLATFORM OR OTHER WORK-AID MUST BE PROVIDED.
- ALWAYS DISCONNECT THE MAIN ELECTRICAL POWER SOURCE BEFORE CLEANING, IF MAINTENANCE OR SERVICE IS PERFORMED, OR IF THE MACHINE IS OUT OF SERVICE.
- NEVER CLEAN OR SERVICE CONVEYOR BELT ON MACHINE, ALWAYS REMOVE BELT FROM MACHINE TO CLEAN OR SERVICE (WHEN APPLICABLE).
- NEVER LEAVE THIS MACHINE RUNNING UNATTENDED.
- GUARDS ARE INTERLOCKED, MACHINE WILL NOT OPERATE WITHOUT GUARDS IN PLACE.

## IMPORTANT:

IF YOU HAVE ANY QUESTIONS ABOUT THESE SAFETY RULES, SEE YOUR SUPERVISOR OR CALL A.M. MANUFACTURING Co. TOLL FREE: (800)342-6744

# OPERATING INSTRUCTIONS



## WARNING:

UNIT MUST BE PROPERLY OPERATED AND MAINTAINED TO PREVENT MACHINE DAMAGE OR PERSONAL INJURY. REVIEW INSTRUCTIONS WITH ALL EMPLOYEES BEFORE USE.

### I. PRELIMINARY START UP DIVIDER

- A. REMOVE SMALL INSPECTION DOOR.
- B. REMOVE PACKING, PACKING SLIPS, DOCUMENTS AND OTHER OBSTRUCTIONS FROM HOPPER.
- C. PLUG POWER CORD INTO PROPER RECEPTACLE.
- D. PUSH DIVIDER START BUTTON AND TEST BUTTON SIMULTANEOUSLY AND HOLD.
- E.  **CAUTION** (THIS WILL START DIVIDER ONLY)
- F. CHECK ROTATION OF DIVIDER BY LOOKING THROUGH SMALL INSPECTION DOOR. LARGE GEAR FOR DIVIDER SHOULD BE TURNING (C.W.) CLOCK-WISE.
- G. IF THE GEAR IS TURNING IN THE (C.C.W.) COUNTER CLOCK-WISE DIRECTION, CONSULT A PROPERLY TRAINED ELECTRICIAN.
- H. IF ROTATION IS CORRECT, YOU ARE READY TO CONTINUE INSPECTION OF THE ROUNDER CONVEYOR.
- I. REINSTALL SMALL INSPECTION DOOR.
- J. SHUT OFF DIVIDER.

### II. PRELIMINARY START-UP ROUNDER

- A. MAKE SURE CONVEYOR IS SECURELY FASTENED TO CABINET.
- B. INSTALL GEAR MOTOR BREATHER (OIL VENT)
- C. BE SURE CONVEYOR IS CLEAR AND NOT OBSTRUCTED.
- D. CHECK ROUNDER MOTOR CORD CONNECTION TO CABINET RECEPTACLE.
- E. TURN ON LARGE CONVEYOR POWER SWITCH. THIS WILL START CONVEYOR MECHANISM.
- F. CHECK CONVEYOR BELT, CONVEYOR BELT SHOULD BE RUNNING FORWARD, OUT FROM MACHINE.
- G. IF CONVEYOR BELT IS RUNNING BACKWARDS, INTO MACHINE, CONSULT A PROPERLY TRAINED ELECTRICIAN.
- H. SHUT OFF DIVIDER.

### III. OPERATION OF DIVIDER

- A. FILL THE OIL RESERVOIR WITH LIGHT WEIGHT MINERAL OIL.
- B. WITH THE SQUIRT BOTTLE SUPPLIED, APPLY A SMALL AMOUNT OF MINERAL OIL TO THE INSIDE WALLS OF THE DOUGH HOPPER.
- C. OPEN THE VALVE LOCATED ON THE TOP GIB BAR APPROXIMATELY 1/8 OF A TURN.
- D. REMOVE BACK CABINET DOOR.
- E. OPEN THE CYLINDER VALVE APPROXIMATELY 1/8 OF A TURN. THIS VALVE IS LOCATED ON THE OIL PUMP INSIDE OF THE REAR DOOR.
- F. REINSTALL THE BACK CABINET DOOR.
- G. FILL THE HOPPER WITH DOUGH.
- H. SET HOPPER COVER ON TOP OF DOUGH.
- I. SWITCH LARGE CONVEYOR SWITCH TO THE "ON" POSITION.
- J. SWITCH SMALL CONVEYOR SWITCH TO THE "ON" POSITION.
- K. PRESS DIVIDER BUTTON.
- L. HOPPER SHOULD BE OILED EVERY TIME NEW DOUGH IS PLACED IN HOPPER.

### IV. DIVIDING THE DOUGH

- A. DOUGH IS PORTIONED IN THE MEASURING CUP LOCATED ON THE DIVIDER SLIDE.

- B.  TO ADJUST THE WEIGHT, STOP THE MACHINE.
- C. LOOSEN THE STAR KNOB NUT (529MS-2D) AND TURN THE SMALL HANDLE ON THE TOP OF THE MEASURING CUP. **NOTE: ALWAYS LOOSEN STAR KNOB PRIOR TO ADJUSTING MEASURING CUP. FAILURE TO DO SO CAN RESULT IN DAMAGE TO CUP.**
- D. BY TURNING THE HANDLE, THE STOP COVER OF THE CUP WILL MOVE UP OR DOWN. THE "UP" (C.C.W.) MOTION WILL INCREASE THE DOUGH WEIGHT. THE "DOWN" (C.W.) MOTION DECREASES THE DOUGH WEIGHT.
- E. FIND YOUR DESIRED DOUGH WEIGHT BY WEIGHING THE DOUGH PIECES.
- F. ONCE YOU HAVE ACHIEVED THIS, LOCK THE STAR KNOB (529MS-2D) ON THE SIDE OF THE MEASURING CUP TO KEEP SCALING ACCURATE.

### V. SECOND STAGE DIVIDER

AFTER THE DOUGH HAS BEEN DIVIDED, IT WILL TRANSFER FROM THE SMALL DROP CONVEYOR TO THE LARGE CONVEYOR AND CONTINUE THROUGH THE SECOND STAGE DIVIDER. IT IS THEN DIVIDED AGAIN AUTOMATICALLY INTO 3, 4 OR 5 EQUAL PIECES, ACCORDING TO THE SIZE REQUIRED.

- A. THE SECOND STAGE DIVIDER HAS BEEN PRE-ADJUSTED AT THE FACTORY. THE PRESSURE PLATE HAS BEEN SECURED FOR SHIPPING PURPOSES. VERIFY ADJUSTMENT PRIOR TO USE.
- B. TO OPERATE THE SECOND STAGE DIVIDER YOU MUST FIRST BE CERTAIN IT IS DISCONNECTED FROM THE POWER SOURCE. NEXT RAISE THE PRESSURE PLATE APPROXIMATELY 1 1/2" FROM THE CONVEYOR BELT. THIS IS ACCOMPLISHED BY LOOSENING THE WING BOLT (PART NO.F0604WB) AND THEN RAISING THE HANDLE (PART NO.MPP15) TO THE DESIRED HEIGHT.
- C. LOCK THE PRESSURE PLATE IN PLACE BY TIGHTENING THE WING BOLTS (PART NO.F0604WB). RECONNECT POWER SOURCE.
- D. SWITCH THE LARGE CONVEYOR TO THE "ON" POSITION.
- E. SWITCH THE SMALL CONVEYOR TO THE "ON" POSITION.
- F. PUSH THE DIVIDER START BUTTON. AFTER CHECKING TO BE SURE THE CONVEYORS ARE CLEAR.
- G. AFTER DOUGH IS DIVIDED, DOUGH PIECES SHOULD BE SPREAD INTO A STRAIGHT EVEN SHAPE AFTER IT COMES OUT OF PRESSURE PLATE. AN INCONSISTENT SHAPE WILL CAUSE INCONSISTENT PIECES OUT OF THE SECOND STAGE DIVIDER

**NOTE:** TO MUCH PRESSURE ON THE DOUGH PIECE GOING THROUGH THE PRESSURE PLATE WILL CAUSE THE PIECE TO ARCH FORWARD IN THE CENTER THIS CAN CAUSE THE MIDDLE PIECES FROM THE SECOND STAGE DIVIDER TO BE HEAVIER THAN THE END PIECES. TOO LITTLE PRESSURE WILL NOT GIVE AN EVEN SPREAD CAUSING DOUGH PIECES TO BE HEAVY ON ONE SIDE.

- A.  IF DESIRED RESULTS ARE NOT ACHIEVED. STOP MACHINE.
- B. REPEAT STEPS 2 THROUGH 6.
- C. AFTER ACHIEVING DESIRED RESULT, MAKE A NOTE OF THE SETTING OF THE PRESSURE PLATE BY USING THE NUMBER LOCATED ABOVE THE ADJUSTING HANDLE.

# CLEANING PROCEDURES

THESE PROCEDURES ARE VERY IMPORTANT TO MAINTAIN  
PRODUCT QUALITY AND MACHINE PERFORMANCE.

ALL A.M. MANUFACTURING MACHINE ARE TESTED WITH DOUGH DURING THE IN-HOUSE RUN-IN AND QUALITY AUDIT PROCEDURE. ALTHOUGH THE MACHINE HAS BEEN CLEANED, SOME EVIDENCE OF DOUGH ON AND IN THE MACHINE MAY BE DETECTED. THIS IS NORMAL. ALL PARTS IN CONTACT WITH DOUGH SHOULD BE WASHED THOROUGHLY AFTER USE, USING A MILD SOAP AND WATER SOLUTION. DISASSEMBLY OF THIS MACHINE FOR CLEANING IS OUTLINED BELOW AND ILLUSTRATED FOR YOUR CONVENIENCE.

## I. DIVIDER



### A. **DANGER: SHUT OFF ALL ELECTRICAL POWER.**

- B. REMOVE COVER OVER DRIVE END OF SLIDE.
- C. LOOSEN FOUR (4) SOCKET SCREWS AT TOP OF CUP; TWIST AND REMOVE CUP.
- D. REMOVE INSERT. (IF APPLICABLE).
- E. REMOVE TWO (2) END BOLTS AT DRIVE END OF SLIDE.
- F. LOOSEN EIGHT (8) HEX HEAD NUTS AT TOP OF GIB BARS AND REMOVE SLIDE.
- G. REMOVE GIB BARS.
- H. REMOVE PISTON BY - INSERTING CRANK THEN:
  - 1. LOOSEN TWO (2) SCREWS ON SLIDE OF SPRING ASSEMBLY AND SLIDE TO RIGHT.
  - 2. REMOVE UPPER PIN AND CRANK ASSEMBLY THROUGH ONE (1) ROTATION, THUS SEPARATING THE SHAFT.
  - 3. PUT LOWER PIN IN UPPER HOLE AND ROTATE UNIT PISTON COMES OUT OF THE CYLINDER.
  - 4. REMOVE AND CLEAN.
  - 5. REMOVE SEAL SCRAPER RING AND "O" RING ON FACING OF CYLINDER AND CLEAN.
  - 6. CLEAN ALL DOUGH RESIDUE OFF OF FACING AND INNER CYLINDER. MAKE SURE YOU CLEAN OUT THE OIL HOLE. (CHECK VALVE).
- I. REPLACE PISTON BY:
  - 1. MAKING SURE PISTON IS IN EXTENDED POSITION W / PIN IN UPPER HOLE.
  - 2. PUT PISTON IN CYLINDER - GUIDING SHAFT INTO THE SPRING ASSEMBLY.
  - 3. TAKE OTHER PIN AND PUT IT THROUGH SPRING ASSEMBLY AND LOWER SHAFT HOLE.
  - 4. ROTATE CRANK UNTIL UPPER PIN IS VISIBLE AND REMOVE.
  - 5. TURN CRANK UNTIL SHAFT COLLAPSES AND TWO (2) UPPER HOLES MEET, INSERT PIN AND PUSH SLIDE OVER AND TIGHTEN ALLEN SCREWS.
  - 6. BE SURE PISTON IS COLLAPSED BY MAKING ONE FULL ROTATION NOTING THAT PISTON DOSE NOT COME ABOVE UPPER CYLINDER.
- J. REPLACE GIB BARS & SLIDE AND ATTACH TWO (2) END BOLTS TIGHTLY.
- K. TIGHTEN THE EIGHT (8) HEX HEAD NUTS ON THE GIB BARS.
- L. REPLACE INSERT & MEASURING CUP, RE-TIGHTEN FOUR (4) SOCKET HEAD SCREWS.
- M. PUT SAFETY COVER BACK OVER DRIVE END OF SLIDE.

## II. SECOND STAGE DIVIDER:



- A. **DANGER: SHUT OFF ALL ELECTRICAL POWER.**EMPTY CRUMB PAN (PART NO. 153RC).
- B. WIPE OFF SCRAPER (PART NO. 132RC).
- C. RELEASE SECOND STAGE DIVIDER UNIT BY PULLING AWAY FROM CABINET.
- D. NOW PIVOT SECOND STAGE DIVIDER UNIT UP, AWAY FROM THE CONVEYOR.
- E. CLEAN SECOND STAGE DIVIDER UNIT AND WIPE DOWN REST OF ASSEMBLY.
- F. CLEAN AND SCRAPE EXCESS DOUGH FROM BELT.
- G. RE-ATTACH SECOND STAGE DIVIDER UNIT.



### **PRACTICE SAFETY FIRST:**

ALWAYS DISCONNECT ELECTRICAL SERVICE WHEN CLEANING OR MAINTAINING THIS MACHINE, THUS AVOIDING CHANCE OF SERIOUS INJURIES. MACHINES ARE NOT DANGEROUS IF COMMON SENSE IS APPLIED AND THE INSTRUCTIONS ARE CAREFULLY FOLLOWED. THINK AND PRACTICE SAFETY FIRST.

## GUIDE TO CLEANING



### DANGER:

ALWAYS DISCONNECT ELECTRICAL POWER SOURCE WHEN CLEANING, MAINTAINING OR REPAIRING THIS MACHINE.

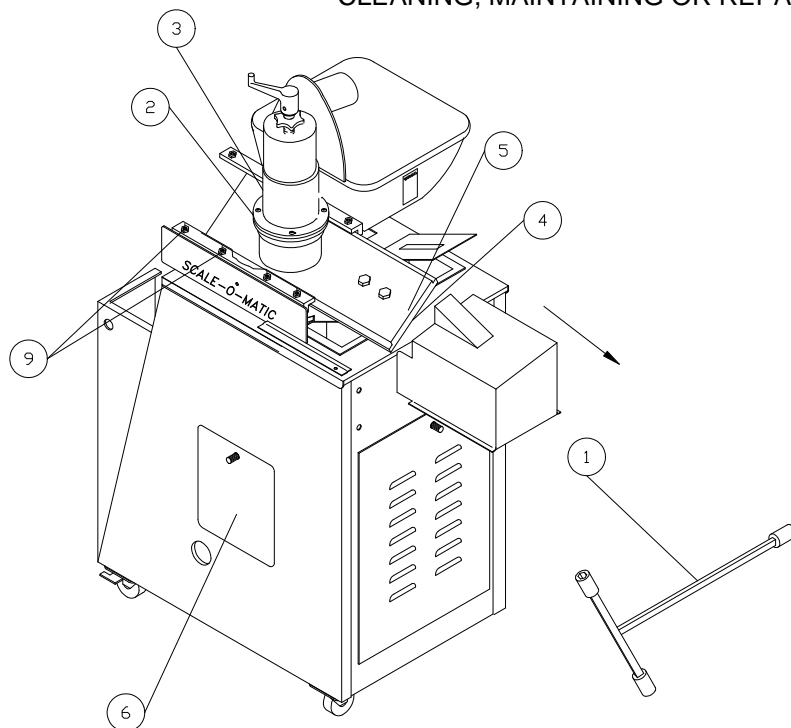

FIGURE 1

### STEP 1

USING AN ALLEN WRENCH, LOOSEN SOCKET HEAD SCREWS (2) AND LIFT OFF DIVIDER PLUNGER (MEASURING CUP) (3). WHEN A #2 OR #3 MEASURING CUP IS USED ON DIVIDER, THE DIVIDER CYLINDER MUST ALSO BE REMOVED FROM SLIDE FOR CLEANING.

### STEP 2

LOOSEN EIGHT HEX HEAD BOLTS AT TOP OF GIB BARS. USING WRENCH (1) REMOVE TWO HEX HEAD SCREWS (4) AND PUSH DIVIDER SLIDE (5) REARWARD TO EXPOSE CYLINDER OPENING.

### STEP 3

REMOVE CABINET DOOR (6).

### STEP 4

WITH CYLINDER OPENING EXPOSED, REMOVE SEAL SCRAPER RING (7) AND RUBBER "O" RING (8). CLEAN ALL EXPOSED SURFACES INCLUDING "O" RING GROOVE AND DIVIDING SLIDE OF ACCUMULATED DOUGH, OIL, ETC. WIPE EXCESS DOUGH FROM TOP AND INTERIOR OF CYLINDER.

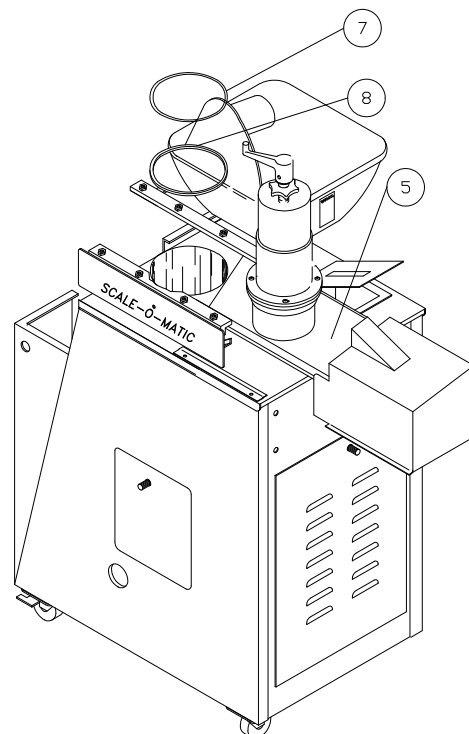

FIGURE 2

### SCALE - O - MATIC NAME PLATE

THIS PLATE HAS A 2-CHANNEL GROOVE THAT CATCHES EXCESS OIL AND DRAINS INTO DRIP PAN AT THE BOTTOM OF THE MACHINE. THIS PLATE SHOULD BE REMOVED BY LOOSENING AND REMOVING A SMALL ALLEN SCREW IN THE CENTER OF THE PLATE. CLEAN PLATE, AND CHECK PLASTIC DRAIN LINE TO SEE THAT IT IS CLEAN AND FREE OF ANY SEDIMENT SO OIL CAN DRAIN PROPERLY. DRIP PAN AT BOTTOM OF MACHINE SHOULD BE EMPTIED EVERY DAY.

## GUIDE TO CLEANING

### STEP 5

LOOSEN SOCKET SCREWS (9) ENOUGH TO SLIDE PIN LOCK BRACKET (10) EXPOSING LOCK PIN (11). REMOVE PIN (11).

### STEP 6

INSERT CRANK HANDLE (12) THROUGH HOLE IN CABINET AND ENGAGE WITH PINION SHAFT. CRANK ONE COMPLETE TURN COUNTER CLOCK-WISE THUS EXTENDING PISTON ROD UNTIL HOLE (14) IS IN LINE WITH UPPER HOLE IN ROD (13).

### STEP 7

PLACE PIN (11) INTO HOLE (14) TEMPORARILY. NOW REMOVE PIN (15), CONTINUE TO CRANK UNTIL PISTON (16) EMERGES FROM THE TOP OF THE CYLINDER. LIFT OUT CAREFULLY BY HAND. THOROUGHLY CLEAN PISTON AND CYLINDER TO REMOVE ALL ACCUMULATED DOUGH WITH A MILD SOAP AND WASTER SOLUTION. DRY THOROUGHLY AND COAT ALL SURFACES WITH A LIGHT COATING OF DIVIDER OIL. TO REASSEMBLE, REVERSE STEPS 1 THROUGH 7.

WHEN CLEANING OR ADJUSTING PISTON, DO NOT OVER TIGHTEN ADJUSTING NUTS. THIS WILL OVER SPREAD YOUR PLASTIC PISTON RING AND WILL CAUSE EXCESSIVE WEAR, AND IT WILL ALSO BE HARD TO REPLACE PISTON BACK INTO THE CYLINDER. THIS COULD RESULT IN THE CUTTING OF YOUR PISTON RING WHICH WOULD DESTROY YOUR PISTON RING.

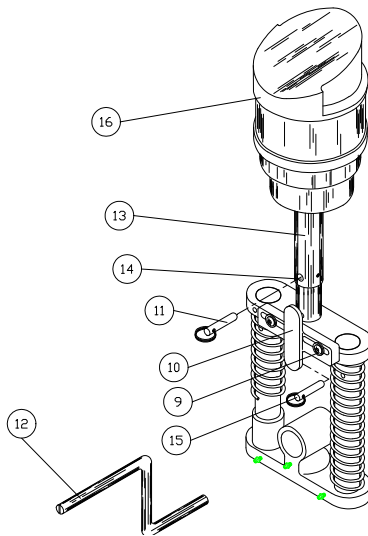

FIGURE 3

**IMPORTANT:** WHEN RE-ASSEMBLING, DO NOT OVER TIGHTEN ANY OF THE SCREWS, AS THIS TENDS TO STRIP THREADS CAUSING PROBLEMS IN THE FUTURE. BE SURE RING ON PIN (11) OF FIGURE 3 IS SECURELY FASTENED OVER LATCH (10). THIS WILL PREVENT LATCH FROM MOVING, SHOULD THE SOCKET HEAD SCREWS (9) LOOSEN DURING OPERATION.

### **!** DANGER:

ALWAYS DISCONNECT ELECTRICAL POWER SOURCE WHEN CLEANING, MAINTAINING OR REPAIRING THIS MACHINE....

### REPLACEMENT OF PISTON RING

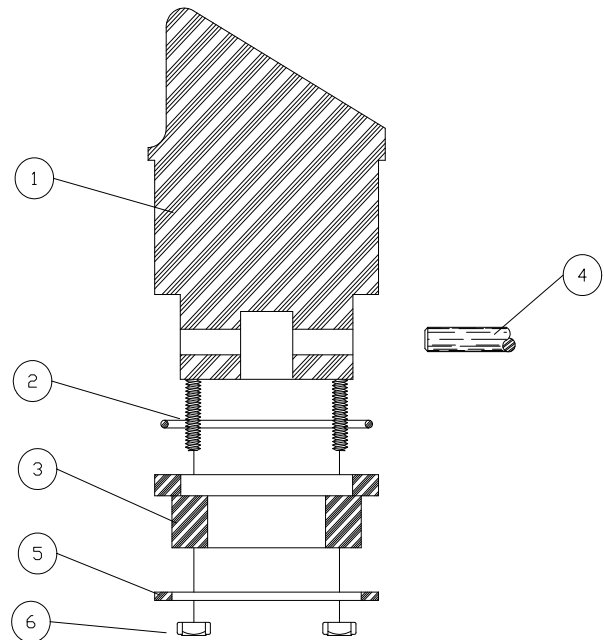

FIGURE 4

TO DISMANTLE PISTON IN FIGURE 4, REMOVE THE SIX HEX NUTS (6), SLIP RING (5) DOWN AND OFF, THEN WITH SLIGHT PRESSURE, PUSH PISTON RING (3) OFF PISTON AND RUBBER "O" RING (2). WHEN REASSEMBLING THE PISTON, A VERY **IMPORTANT** STEP IS TO MAKE SURE THE SIX NUTS (6) ARE NOT OVERLY TIGHTENED, MERELY SNUG. AS THE RING WEARS OVER A PERIOD OF TIME, CONTINUE TO SNUG UP THE SIX NUTS. THIS PROCEDURE WILL NOT ONLY PROVIDE LONG LIFE TO THE PISTON RING BUT WILL MAINTAIN FULL VACUUM.

## GUIDE TO CLEANING



### DANGER:

ALWAYS DISCONNECT ELECTRICAL POWER SOURCE WHEN CLEANING, MAINTAINING OR REPAIRING THIS MACHINE...

LOWER LARGE CONVEYOR BEFORE MOVING OR RELOCATING MACHINE...

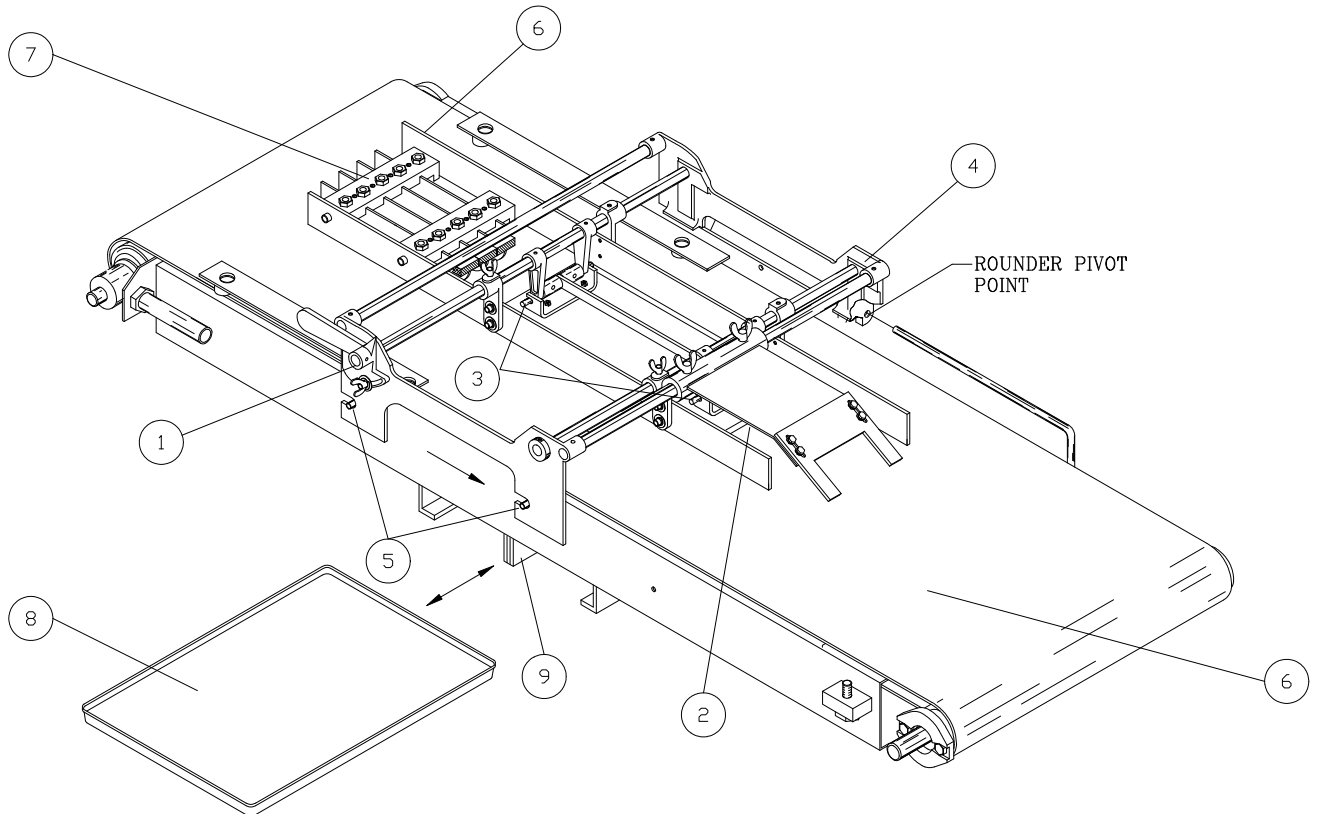

**STEP 1**  
RAISE PRESSURE PLATE ASSEMBLY (1), SLIDE PRESSURE PLATE (2) TOWARDS UNIT UNTIL DISENGAGED FROM THE PRESSURE PLATE MOUNTING RODS (3).



### CAUTION:

THIS STEP MUST BE PERFORMED FIRST TO PREVENT PRESSURE PLATE FROM SLIPPING OFF.

**STEP 2**  
SLIDE MOUNTING FRAME (4) TOWARDS UNIT UNTIL DISENGAGED FROM SPACER (5). PIVOT MOUNTING FRAME (4) UP UNTIL IT RESTS IN CLEANING POSITION. CLEAN GUIDES (6) AND CUTTER ASSEMBLY (7).

**STEP 3**  
CLEAN PRESSURE PLATE (2).

**STEP 4**  
REMOVE EXCESS DOUGH FROM BELT.

**STEP 5**  
SET PRESSURE (2) IN POSITION ON BELT.

**STEP 6**  
PIVOT MOUNTING FRAME (4) DOWN, CAREFULLY ALIGNING PRESSURE PLATE (2) INTO POSITION BETWEEN GUIDES.

**STEP 7**  
POSITION PRESSURE PLATE (2) ONTO PRESSURE PLATE MOUNTING RODS (3).

**STEP 8**  
SLIDE MOUNTING FRAME (4) BACK ONTO SPACERS (5).

**STEP 9**  
REMOVE CRUMB TRAY (8) BY SLIDING IT OUT FROM UNDER CONVEYOR.

**STEP 10**  
TO CLEAN THE SCRAPER BLADE (9), LOCATE BLADE UNDERNEATH THE CONVEYOR AND REMOVE EXCESS DOUGH.

# GUIDE TO GENERAL MAINTENANCE

**READ AND FOLLOW MAINTENANCE INSTRUCTIONS** BELOW TO HELP KEEP THE UNIT IN GOOD OPERATING CONDITION. REFER TO OTHER MATERIALS RECEIVED WITH THE UNIT AND TO SERVICE BULLETINS FROM THE MANUFACTURER FOR ADDITIONAL INSTRUCTIONS FOR PROPER MAINTENANCE AND SERVICE. REGULAR INSPECTIONS AND PROPER MAINTENANCE ARE ESSENTIAL TO HELP PREVENT ACCIDENTS AND INJURIES.



## PRACTICE SAFETY FIRST:

ALWAYS DISCONNECT ELECTRICAL SERVICE WHEN CLEANING OR MAINTAINING THIS MACHINE, THUS AVOIDING CHANCE OF SERIOUS INJURIES. MACHINES ARE NOT DANGEROUS IF COMMON SENSE IS APPLIED AND THE INSTRUCTIONS ARE CAREFULLY FOLLOWED. THINK AND PRACTICE SAFETY FIRST...



## WARNING:

BEFORE MAKING ANY INSPECTION, ADJUSTMENT OR REPAIR, BE CERTAIN POWER SOURCE IS DISCONNECTED AND ALL MOVING PARTS ARE BLOCKED OUT TO PREVENT INJURY. WEAR PROTECTIVE CLOTHING.

- A. ALL WORKING SURFACES SHOULD BE CLEANED REGULARLY.
- B. THE TABLE TOP AND OTHER WORKING SURFACES SHOULD BE CLEANED REGULARLY.
- C. MAKE SURE THAT ALL FASTENERS ARE TIGHTENED SECURELY.
- D. MAKE CERTAIN THAT ALL GUARDS AND COVERS ARE IN PLACE.
- E. CHECK FOR WORN, DAMAGED OR MISSING PARTS INCLUDING BELTS, SAFETY GUARDS AND PROTECTIVE COVERS.
- F. ON A DAILY BASIS, INSPECT THE UNIT AND CHECK TO BE CERTAIN THAT ALL SYSTEMS ARE OPERATING NORMALLY. DETAILED INSPECTION AND TESTING PROCEDURES ARE SPECIFIED FOR VARIOUS COMPONENTS AT REGULAR INTERVALS. SET UP A CHART AND ASSIGN RESPONSIBILITY FOR THESE ITEMS.



## CAUTION:

REPLACE ANY DAMAGED OR MISSING SAFETY LABELS. THEY ARE AVAILABLE FROM THE MANUFACTURER.

MAINTENANCE FOR THE SCALE - O - MATIC S500 ALWAYS BEGINS WITH KEEPING THE MACHINE CLEAN. PROPER CLEANING PROCEDURES CAN BE FOUND ON PAGES 8 - 11 OF THIS MANUAL. STANDARD LONG TERM MAINTENANCE CONSISTS OF LUBRICATING MAIN WEAR POINTS OF THE MACHINE WITH AN ALL-PURPOSE LITHIUM BASE GREASE. A GREASE GUN WITH A FLEXIBLE HOSE IS NEEDED.

ALL RECOMMENDATIONS FOR MAINTENANCE, BASED ON A 7 DAY, 8 HOUR PER DAY WORK SCHEDULE.

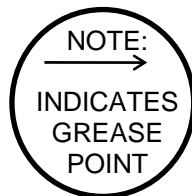

THERE ARE (5) GREASE FITTINGS LOCATED ON THE ROCKER ARM AND DIVIDER FRAME, (FIG. 1). THESE FITTINGS SHOULD BE LUBRICATED ONCE A WEEK FOR OPTIMUM BEARING LIFE.

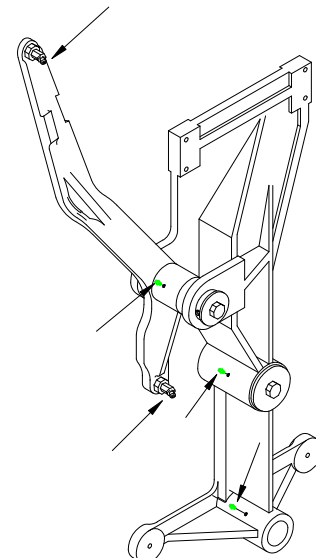

**FIGURE 1**

FOLLOW NORMAL CLEANING AND MAINTENANCE PROCEDURES OUTLINED IN THIS MANUAL. FOR FURTHER ASSISTANCE CONTACT THE A.M. MFG. SERVICE DEPARTMENT AT (800) 342-6744...

## GUIDE TO GENERAL MAINTENANCE



### DANGER:

ALWAYS DISCONNECT ELECTRICAL SERVICE WHEN CLEANING, MAINTAINING OR REPAIRING THIS MACHINE...

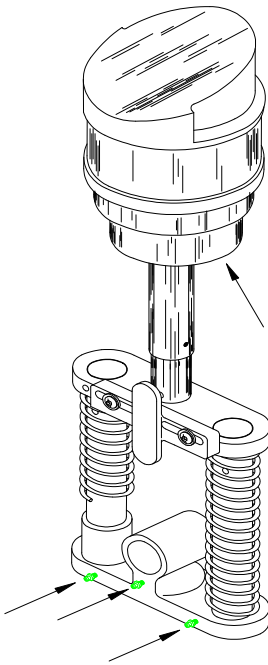
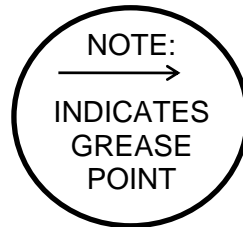

FIGURE 2

THE PISTON AND SPRING LOAD ASSEMBLY HAVE A TOTAL OF (4) GREASE FITTINGS, (FIG. 2). THREE (3) OF THESE FITTINGS ARE FOUND ON THE LOWER CASTING OF THE SPRING LOAD. APPLY A SMALL AMOUNT OF GREASE TO THESE FITTINGS ONCE A WEEK. THE SAME PROCEDURE SHOULD BE FOLLOWED FOR THE GREASE FITTING UNDER THE PISTON, (FIG. 4). THIS FITTING IS LOCATED ON THE TOP OF THE OUTSIDE CONNECTING ROD, (PART NO. 322PY).

### NOTE:

THIS FITTING CAN ONLY BE REACHED WITH A FLEXIBLE HOSE GREASE GUN OR BY REMOVING THE PISTON.



YOU MAY FIND UPON INSPECTION OF THE PISTON THAT THE DOUGH HAS SEEPED INTO THE CUP. THIS IS A NORMAL OCCURRENCE AFTER MODERATE PRODUCTION. TO KEEP THE RUBBER "O" RING FROM PREMATURELY DETERIORATING, STRETCHING OR BREAKING, INSPECT AND CLEAN EVERY (4) WEEKS IN THE FOLLOWING MANNER, (FIG. 3). DISASSEMBLE THE PISTON BY REMOVING THE HEX NUTS ON THE BASE OF THE PISTON ASSEMBLY. REMOVE THE STEEL WASHER (PART NO. 302PY) AND PLASTIC PISTON RING (PART NO. 323PY). CAREFULLY CLEAN EXCESS DOUGH FROM THE PISTON AND "O" RING. REASSEMBLE THE PISTON BEING CAREFUL NOT TO OVERTIGHTEN THE PISTON RING.

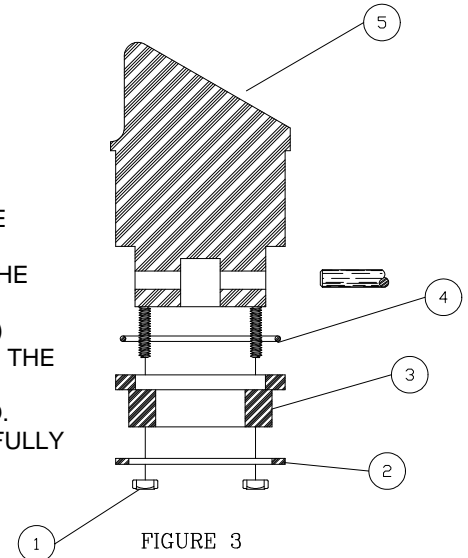

FIGURE 3

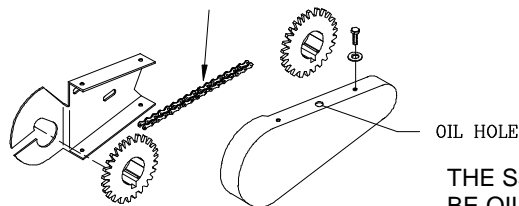

FIGURE 4

THE S500 SCALE - O - MATIC HAS A SINGLE DRIVE CHAIN. THIS PART MUST BE OILED REGULARLY WITH A LIGHT WEIGHT MACHINE OIL TO PROLONG THE LIFE OF THE SPROCKETS, AS WELL AS THE CHAIN. CHAIN CONDITION AND TENSION SHOULD BE CHECKED EVERY (60) DAYS.

FOLLOWING NORMAL CLEANING AND MAINTENANCE PROCEDURES OUTLINED IN THIS MANUAL. FOR FURTHER ASSISTANCE CONTACT THE A.M. MFG. SERVICE DEPARTMENT AT (800) 342-6744...

**NOTE:** THESE INSTRUCTIONS WILL HELP YOU SERVICE THE UNIT. INSTRUCTIONS ARE FOR A PERSON WITH SOME MECHANICAL ABILITY AND TRAINING. NO ATTEMPT HAS BEEN MADE TO DESCRIBE ALL BASIC STEPS, FOR EXAMPLE, HOW TO LOOSEN OR TIGHTEN FASTENERS. ALSO, BASIC PROCEDURES LIKE HOW TO CYCLE SYSTEMS AND CHECK OPERATION OF THE EQUIPMENT ARE NOT DESCRIBED SINCE THEY ARE KNOWN TO ANYONE WHO DOES MECHANICAL AND SERVICE WORK. DO NOT ATTEMPT TO PERFORM WORK BEYOND YOUR ABILITY OR AT WHICH YOU HAVE NO EXPERIENCE. IF YOU NEED ASSISTANCE, CALL AN AUTHORIZED SERVICE CENTER OR CONTACT A.M. MANUFACTURING AT (800) 342-6744...

# CABINET ASSEMBLY

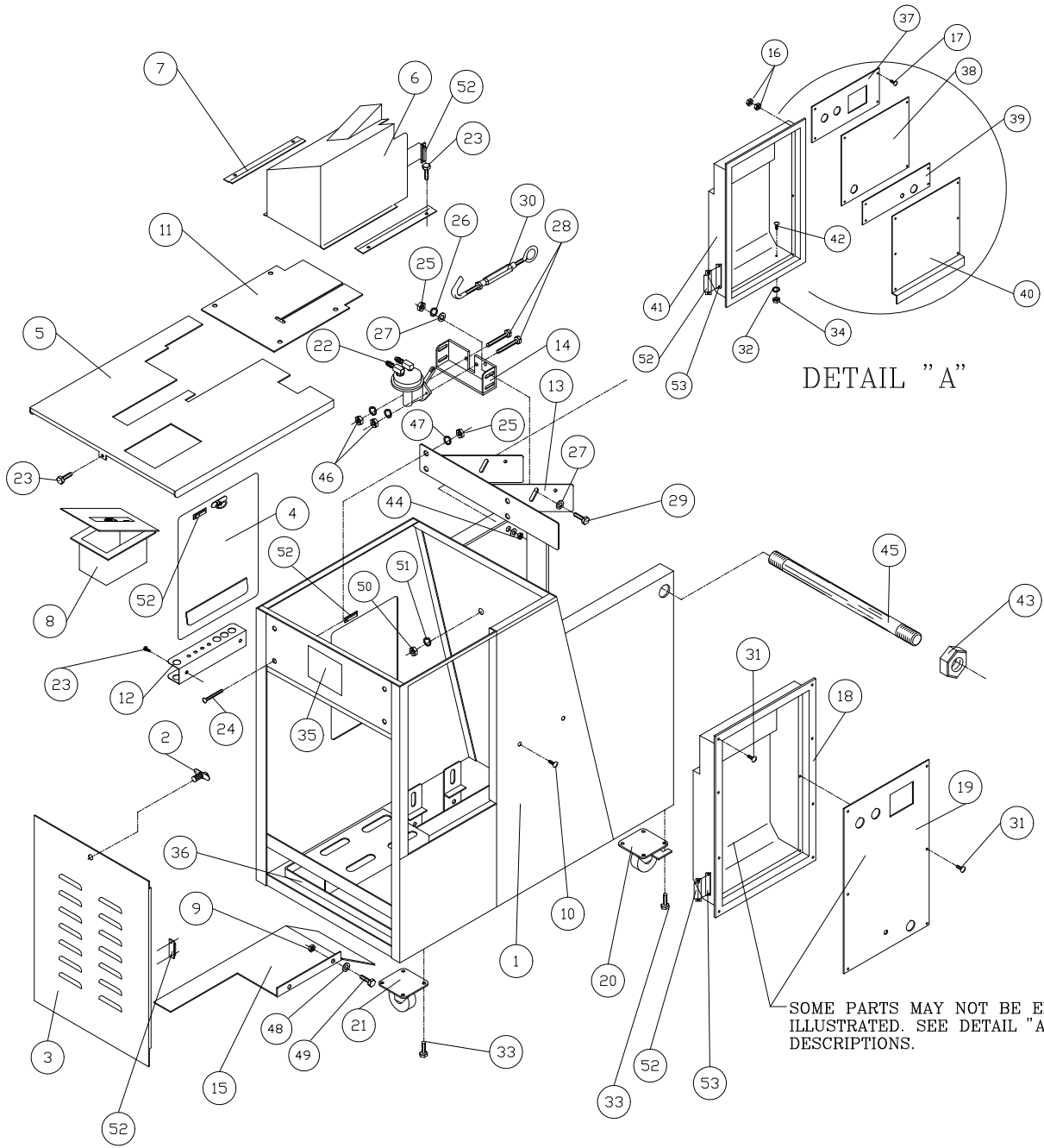

## CABINET ASSEMBLY

ITEM	PART NO.	DESCRIPTION	NO. REQ'D
1	617CA	CABINET	1
2	646CA1	DOOR LOCK LATCH W/2 POP RIVETS	2
3	CA602A	615CA REAR DOOR (INSPECTION) W/646CA1 HARDWARE	1
4	CA600A	611CA FRONT DOOR PISTON DRIVE W/646CA1 HARDWARE	1
5	602CA	TOP COVER	1
6	641CA	ROCKER ARM SAFETY COVER/	1
7	640CA	ROCKER ARM COVER TRACK	2
8	604CA	OIL BOX AND COVER	1
9	F0400NC	NUT	2
10	F0402TH	BOLT	2
11	641CA1	ROCKER ARM COVER GASKET	1
12	638CA	TOOL HOLDER	1
13	605CA1	PUMP BRACKET (LARGE)	1
14	605CA2	PUMP BRACKET (SMALL)	1
15	643CD	"V" BELT GUARD	1
16	F9700NF	NUT	6
17	F9901PH	SCREW	18
18	617CA6	ELECTRICAL ENCLOSURE	1
19	SS116	ELECTRICAL COVER PANEL	1
20	621CA1	SWIVEL CASTER (LOCKING)	2
21	621CA2	SWIVEL CASTER	2
22	716OS	OIL PUMP	1
23	F0204HH	BOLT	9
24	F0503CB	BOLT	4
25	F500NC	NUT	6
26	F0500LW	LOCK WASHER	6
27	F0500FW	FLAT WASHER	8
28	F0606HH	BOLT	2
29	F0504HH	BOLT	4
30	654CA	TURN BUCKLE	1
31	F9901PH	SCREW	14
32	F9900LW	LOCK WASHER	2
33	F0404ST	BOLT	16
34	F9900NF	NUT	10
35	19904	ELECTRICAL PLATE	1
36	19905	OIL PAN (FOR DOUGH)	1
37	617CA4	PUSH BUTTON COVER PANEL	1
38	617CA3	ELECTRICAL ACCESS PANEL (UPPER)	1
39	617CA2	ELECTRICAL ACCESS PANEL (LOWER)	1
40	617CA1	ELECTRICAL COVER PANEL	1
41	617CA5	ELECTRICAL ENCLOSURE	1
42	F9902TH	SCREW	2
43	F1200NC	NUT	2
44	F0500NC	HEX NUT	1
45	628CA	CONVEYOR ARM ROD 3/4" DIA.	1
46	F0600NC	NUT	6
47	F0600LW	LOCK WASHER	6
48	F0400LW	LOCK WASHER	2
49	F0403HH	BOLT	2
50	F0600NC	NUT	4
51	F0600FW	FLAT WASHER	4
52	SS240	MAGNETIC REED SWITCH	3
53	SS335	REED SWITCH MOUNT	1



### IMPORTANT

KNOW YOUR UNIT. COMPARE DIAGRAMS IN THIS MANUAL WITH THE UNIT BEFORE STARTING SERVICE TO OBTAIN MAXIMUM SAFETY AND PERFORMANCE.

### NOTE:

GUARDS ARE INTERLOCKED. MACHINE WILL NOT OPERATE WITHOUT GUARDS IN PLACE.

# CYLINDER AND DRIVER ASSEMBLY

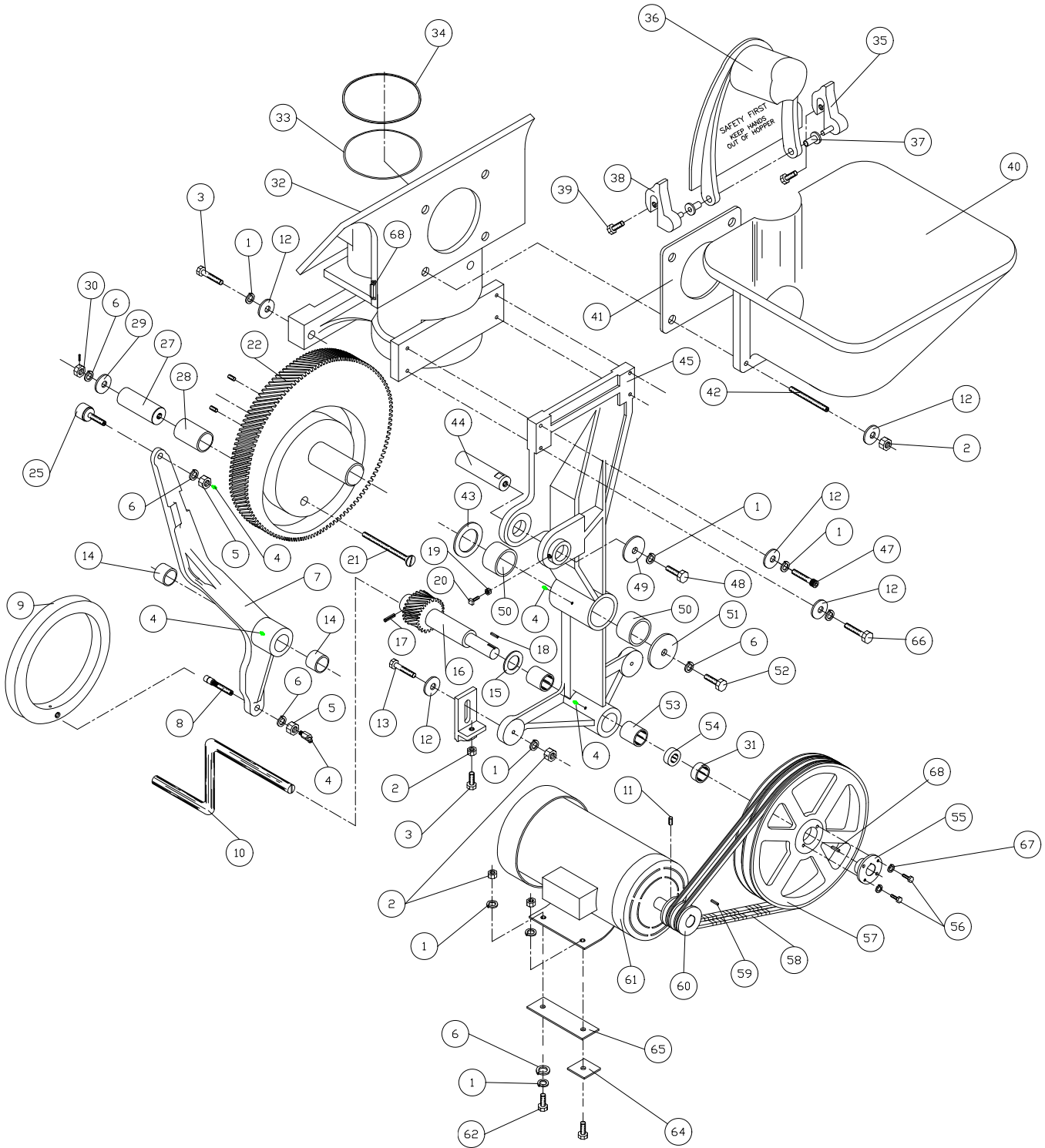

# CYLINDER AND DRIVER ASSEMBLY

ITEM	PART No.	DESCRIPTION	No. REQ'D	ITEM	PART No.	DESCRIPTION	No. REQ'D
1	F0600LW	LOCK WASHER	13	42	F0607SD	STUD	4
2	F0600NC	NUT	12	43	411CD	SPACER WASHER	1
3	F0604HH	BOLT	2	44	412CD	CAM ARM PIN	1
4	3038-B	GREASE FITTING	5	45	S0109CD	MAIN DRIVE FRAME	
5	F0800NF	NUT	2			INCLUDES:	
6	F0800LW	LOCK WASHER	4			2-437CD PINION SHAFT BEARING	
7	S0110CD	ROCKER ARM COMPLETE	1			2-440CD MAIN FRAME BEARING	
		INCLUDES:				2-3038-B GREASE FITTING	
		1-412CD CAM ARM PIN				2- NUTS	
		2-422CD BEARINGS		47	F0609SH	BOLT	1
		1-427CD CAM ROLLER		48	F0604HH	BOLT	1
		W/WASHER, NUT		49	442CD	WASHER, 1-3/4 X 3/8	1
		GREASE FITTING		50	440CD	MAIN FRAME BEARING	2
		1-448CD CAM TRACK SHOE		51	439CD	WASHER 3 X 9/16	2
		1-452CD SHOE BOLT W/		52	F0804HH	BOLT	1
		WASHER, NUT,		53	437CD	PINION SHAFT BEARINGS	2
		GREASE FITTING		54	465CD	BEARING	1
8	452CD	SHOE BOLT W/	1	55	463CD	HUB-PULLEY W/ KEY	1
		WASHER, NUT,		56	F0404HH	BOLT	2
		GREASE FITTING		57	435CD	DRIVE PULLEY(SINGLE GROOVE)	1
9	B-451CD	HEAVY DUTY CAM TRACK SHOE	1		435CD2	DRIVE PULLEY(DOUBLE GROOVE)	
10	426CD	HAND CRANK	1		435CDV	DRIVE PULLEY(VARIABLE GROOVE)	
11	F0501SS	SET SCREW	1	58	434CD-V	"V" BELT (VARIABLE)	1
12	F0600FW	FLAT WASHER	12		434CD49	"V" BELT (49")	
13	F0607HH	BOLT	2		434CD56	"V" BELT (56")	
14	422CD	ROCKER ARM BEARING	2	59	F0304Y	KEY 3/16"	1
15	416CD	WASHER SPACER	1	60	458CD	MOTOR PULLEY (SINGLE GROOVE)	1
16	415CD	DRIVE SHAFT & PINION	1		458CDD	MOTOR PULLEY (DOUBLE GROOVE)	
		INCLUDES:			458CDV	MOTOR PULLEY (VARIABLE)	
		1-F0404KY KEY		61	SS268	ELECTRIC MOTOR (SINGLE PHASE)	1
		1-F0305RP ROLL PIN			SS265	ELECTRIC MOTOR (3 PHASE)	
17	F0305RP	ROLL PIN	1		SS264	ELECTRIC MOTOR (VARIABLE)	
18	F0404KY	KEY W/ 415CD		62	F0605HH	BOLT	4
		(NOT SOLD ALONE)		63	462CD	MOTOR MOUNT	1
19	F0500NC	NUT	1	64	644CA	MOTOR SPACER	2
20	F0506SQ	BOLT	1	65	643CA	MOTOR SHIM	2
21	F0819FH	BOLT	1	66	F0404KY	KEY	1
22	S0113CD	MAIN DRIVE GEAR	1	67	F0400LW	LOCK WASHER	2
		INCLUDES:		68	SS240	MAGNETIC REED SWITCH	1
		1-SCREW					
		1-406CD SHAFT YOKE PIN					
		1-NUT					
		1-SPRING					
		1-409CD SHAFT					
		1-CRANK PIN SCREW					
		1-LOCK WASHER					
		1-FLAT WASHER					
		1-312PY BEARING					
25	427CD	CAM ROLLER W/					
		WASHER, NUT,					
		GREASE FITTING					
27	406CD	SHAFT YOKE PIN (NOT SOLD ALONE)					
		W/S0133CD ONLY					
28	312PY	DRIVE BEARING	1				
29	459CD	SPACER	1				
30	F0800NC	NUT	1				
31	464CD	SPACER	1				
32	S0107CD	CYLINDER	1				
		INCLUDES:					
		1-7080S CHECK VALVE					
		8-F0500CN NUTS					
		8-F0508SD STUDS					
33	402CD	CYLINDER SLIDE "D" RING	1				
34	401CD	SEAL SCRAPER RING	1				
35	456CD	CLAMP, COVER, L.H. HINGE	1				
36	454CD	HOPPER COVER	1				
	CD400A	COMPLETE HOPPER COVER ASSEMBLY					
		W/1-454CD HOPPER COVER					
		1-455CD RIGHT HINGE					
		1-456CD LEFT HINGE					
		2-460CD INSULATORS					
		2-461CD BOLTS					
37	460CD	INSULATORS	2				
38	455CD	CLAMP, COVER R.H. HINGE	1				
39	461CD	BOLTS FOR HINGES	2				
40	445CD	DOUGH HOPPER	1				
41	449CD	HOPPER GASKET	1				

\* NOTE:  
 REPLACEMENT PART NO'S FOR ITEM NO.(50), PART NO. (440CD)  
 440CD1 = 2-3/8 O.D.  
 440CD2 = 2-1/4" O.D.  
 OPTIONAL EQUIPMENT FOR PART NO. (445CD)  
 PART NO. (445CDE EXTENDED HOPPER  
 PART NO. (415CD) FOR OLDER STYLE PINION.

# PISTON-CONNECTING ROD & SPRING ASSEMBLY

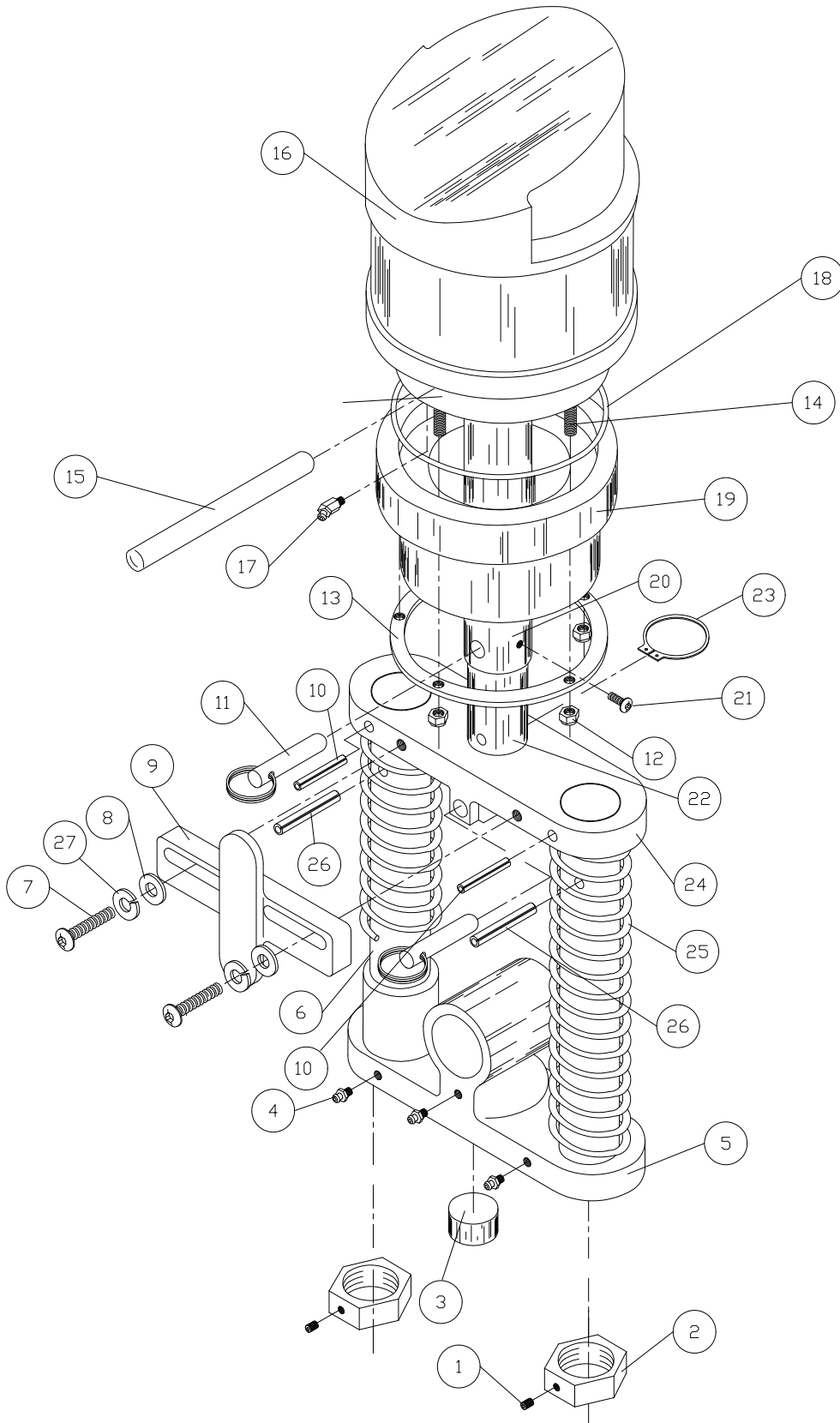

## PISTON - CONNECTING ROD & SPRING ASSEMBLY

<u>ITEM</u>	<u>PART NO.</u>	<u>DESCRIPTION</u>	<u>NO. REQ'D</u>
1	F0401SS	SET SCREW	2
2	315PY	SPRING LOCK NUT	2
3	313PY	EXPANSION PLUG	1
4	3038-B	GREASE FITTING	3
5	310PY	LOWER CASTING & BUSHING W/ 3-3038-B GREASE FITTINGS 1-313PY EXPANSION PLUG	1
6	309PY	SPRING GUIDE BARS (NOT SOLD SEPARATELY) SOLD w/B317PY ONLY	2
7	F0404SB	BOLT	2
8	F0400FW	FLAT WASHER	2
9	306PY	LOCK CONNECTING PIN	1
10	FO408RP	ROLL PIN 1/4 DIA. X 2.0" LG.	2
11	304PY	CONNECTING ROD PIN	2
12	FO400LN	LOCK NUT	6
13	302PY	PISTON RING WASHER	1
14	FO416HS	HANGER SCREW	6
15	301PY	WRIST PIN	1
16	300PY	PLASTIC PISTON ASSEMBLY w/6-F0400LN LOCK NUTS, 1-301PY WRIST PIN 1-302PY PISTON RING WASHER 1-323PY PISTON RING ONLY 1-324PY "O" RING	1
17	3053-B	GREASE FITTING	1
18	324PY	PISTON "O" RING	1
19	323PY	PISTON RING ONLY	1
20	322PY	OUTSIDE CONNECTING ROD	1
21	FO401SB	SOCKET BUTTON HEAD SCREW	1
22	319PY	INSIDE CONNECTING ROD	1
23	318PY	TRU ARC RETAINER WASHER	1
24	317PY	UPPER SPRING CASTING w/2-F0406RP SPRING PINS 2-309PY SPRING GUIDE BARS 2-FO408RP SPRING PINS	1
25	316PYB	COMPRESSION SPRING	2
26	FO406RP	ROLL PIN 1/4 DIA. X 2.0" LG.	2
27	F0400LW	LOCK WASHER	2

# MEASURING CUP & DIVIDER SLIDE

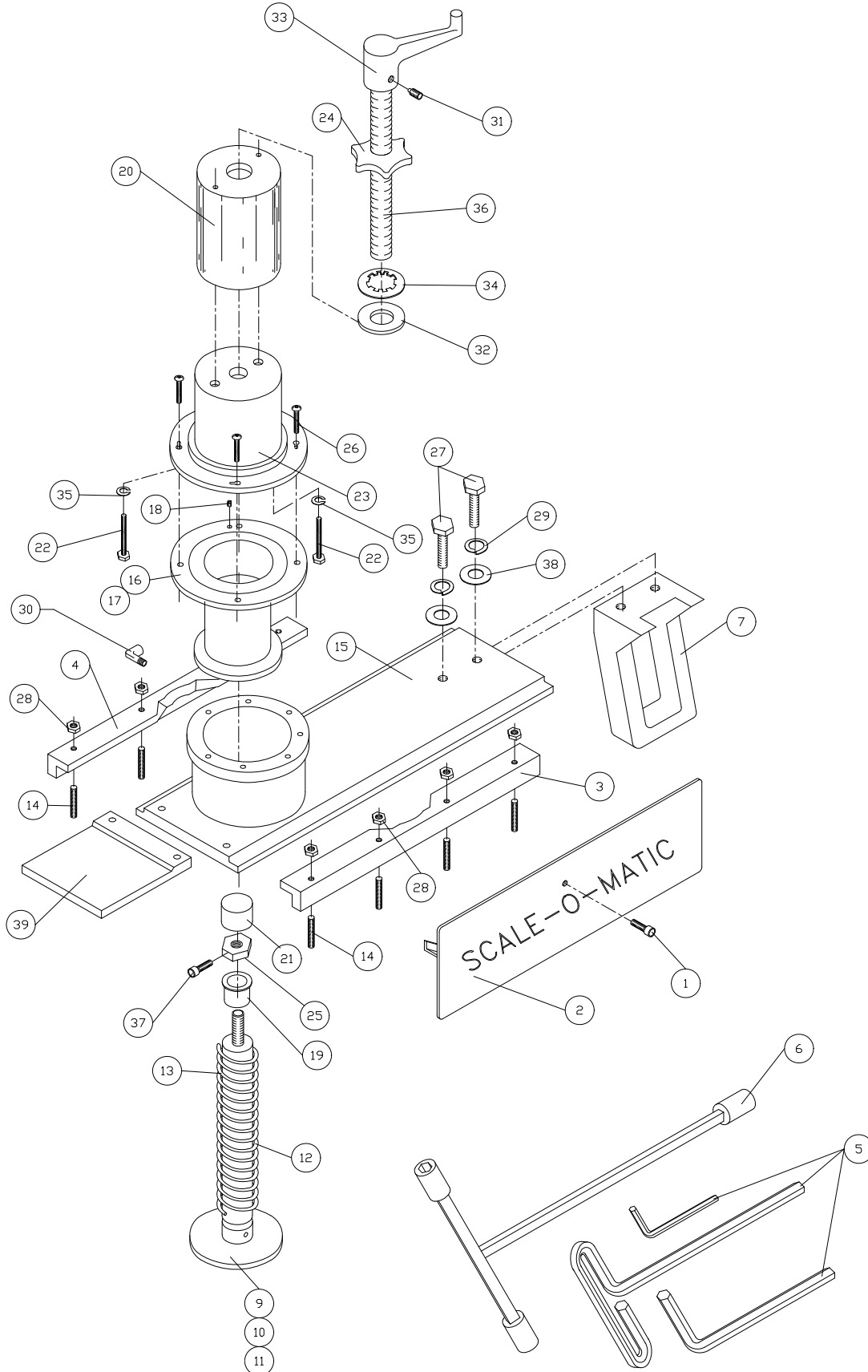

# MEASURING CUP & DIVIDER SLIDE

ITEM	PART NO.	DESCRIPTION	NO. REQ'D
1	F0404SH	SOCKET HD. BOLT	1
2	518MS	NAME PLATE & OIL RETURN	1
3	507MS/B-1	GIB BAR LOWER	1
4	507MS/B-2	GIB BAR UPPER	1
5	530MSW	W/1-7240S 90° STREET ELBOW WRENCHES	1 SET
6	542MSW	1/8", 1/16", 5/32" T-HANDLE T WRENCH	1
7	517MS 517MS/H	CAM ARM SLIDE W/ F0607HH SCREWS CAM ARM SLIDE W/ F0605HH HEAVY SCREWS	
9	513MS-2	2" PLUNGER W/ SPRING W/1-F0304RP ROLL PIN 1-515MS PLUNGER SHAFT 1-516MSL PLUNGER SPRING (LIGHT)	1 UNIT
10	513MS-3	3" PLUNGER W/1-F0304RP ROLL PIN 1-515MS PLUNGER SHAFT	1 UNIT
	513MS-3S	3" PLUNGER W/ SPRING W/1-F0304RP-ROLL PIN 1-515MS PLUNGER SHAFT 1-516MSH PLUNGER SPRING (HEAVY)	1 UNIT
11	513MS-5	5" PLUNGER W/1F0304RP ROLL PIN 1-515MS PLUNGER SHAFT	1 UNIT
12	516MSL	PLUNGER SPRING (LIGHT) FOR 2" PLUNGER	1
13	516MSH	PLUNGER SPRING (HEAVY) FOR 3" & 5" PLUNGER	1
14	F0508SD	STUD	8
15	S511MS	DIVIDER SLIDE	1
16	S509MS	DIVIDER CYLINDER 2"	1
17	S510MS	DIVIDER CYLINDER 3"	1
18	F0401SSS	SET SCREW	4
19	S539MSP	PLASTIC BUSHING	1
20	529MS-2	STOP COVER	1
21	529MS-2E	PLASTIC STOP PLUG	1
22	F0416HH	BOLT	2
23	S503MS	PLUNGER GUIDE HOUSING W/1-S543MS THREADED INSERT	1
24	529MS-2D	STAR KNOB	1
25	531MS	SLOTTED HEX NUT	1
26	F0404SB	SOCKET HEAD BOLT	4
27	F0607HH	HEX HEAD BOLT	2
28	F0500HNC	HEX NUT	8
29	F0600LW	LOCK WASHER	2
30	7240S	STREET ELBOW 90°	1
31	F0502SSDP	SET SCREW W/ FULL DOG POINT	1
32	F1200WF	WASHER	1
33	529MS-2F	ADJUSTABLE HANDLE	1
34	F1200RW	RETAINING WASHER	1
35	F0400LW	LOCK WASHER	2
36	529MS-2C	STUD	1
37	F0403SH	SOCKET HEAD BOLT 3/4" LONG	1
38	F0600HFW	FLAT WASHER	2
39	S539MS	SLIDE GUARD (OLDER MODLE MACHINES)	1

## INDIVIDUAL MEASURING CUP

### ASSEMBLIES

- AMS2 FOR 2oz. TO 4oz. PIECES
- AMS3 FOR 4oz. TO 10oz. PIECES
- AMS5 FOR 10oz. TO 32oz. PIECES

### NOTE:

PART NO. A501MS (COMPLETE STOP COVER ASSEMBLY AVAILABLE TO REPLACE OLD STYLE STOP COVERS).

# SMALL CONVEYOR & DRIVE ASSEMBLY

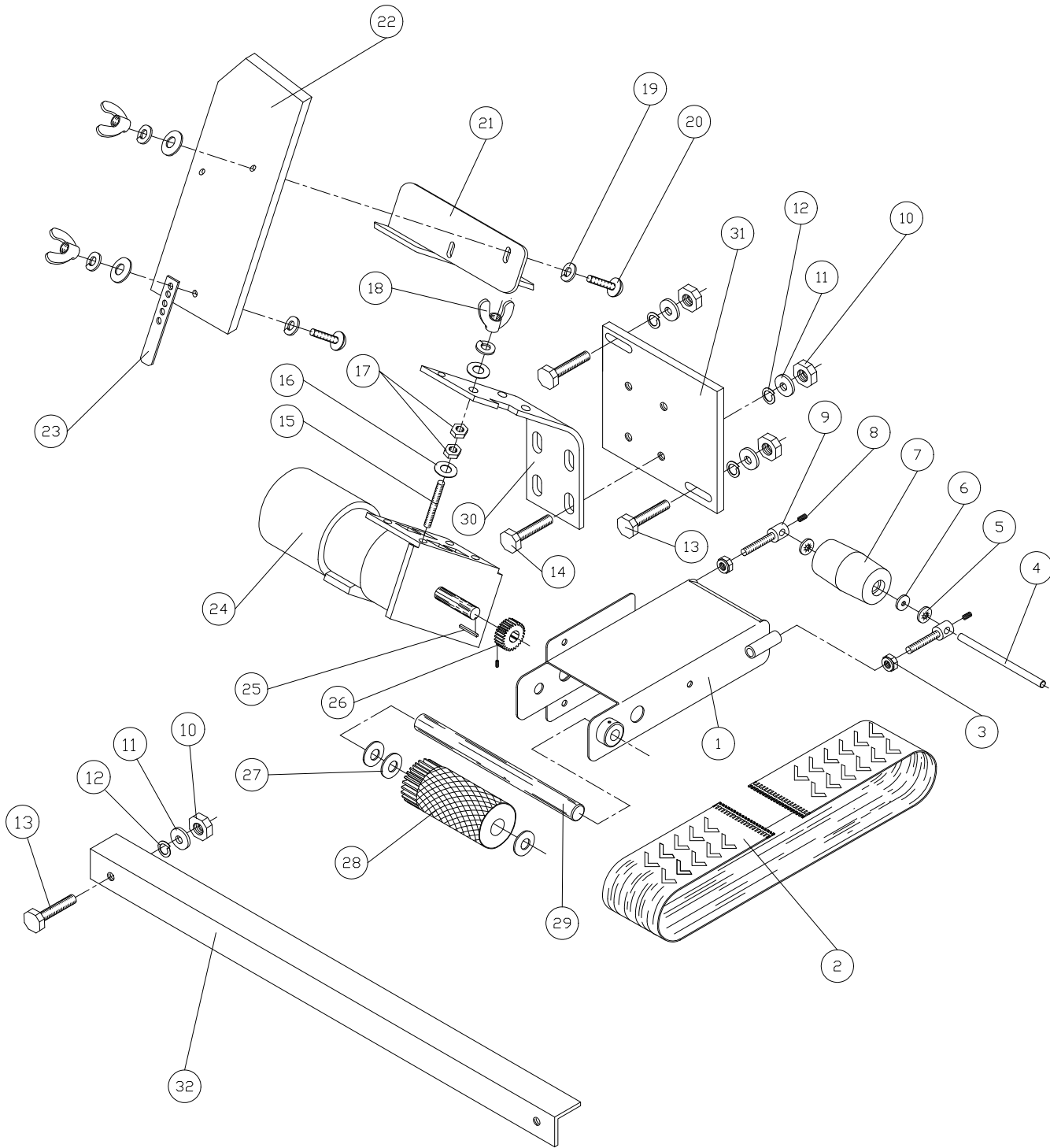

## SMALL CONVEYOR & DRIVE ASSEMBLY

ITEM	PART NO.	DESCRIPTION	NO. REQ'D
1	BSC67	SMALL CONVEYOR FRAME	1
2	BSC3-4	CONVEYOR BELT	1
3	F0600NC	HEX NUT W/ RUBBER INSERT	2
4	BSC72	IDLER ROLLER SHAFT	1
5	F0600RW	RETAINING WASHER	2
6	641SC2	BALL BEARING	2
7	BSC66	IDLER ROLLER	1
8	F0401SS	SET SCREW	2
9	600SC	ROLLER SUPPORT	2
10	F0600NC	HEX NUT	6
11	F0600FW	FLAT WASHER	6
12	F0600LW	LOCK WASHER	6
13	F0604HH	BOLT	2
14	F0602HH	BOLT	4
15	F0408SD	STUD	4
16	F0400FW	FLAT WASHER	8
17	F0400NC	HEX NUT	8
18	F0400WN	WING NUT	7
19	F0400LW	LOCK WASHER	7
20	F0406RH	BOLT	3
21	BSC63	DOUGH GUIDE SUPPORT	1
22	BSC62	PRESSURE PLATE	1
23	BSC62-1	PRESSURE PLATE BRACKET	1
24	SS262	1/6 H.P. GEAR MOTOR	1
25	F0400KY	KEY	1
26	BSC73-1	SPUR GEAR 24T	1
27	F0800WF	FIBER WASHER	3
28	BSC68	DRIVE ROLLER ASSEMBLY	1
29	BSC70	DRIVE ROLLER SHAFT	1
30	BSC65	SMALL CONVEYOR MOUNTING ARM	1
31	BSC76	MOUNTING ARM PLATE	1
32	BSC74	INNER CABINET CONVEYOR SUPPORT BRACE	1

# CONVEYOR ASSEMBLY

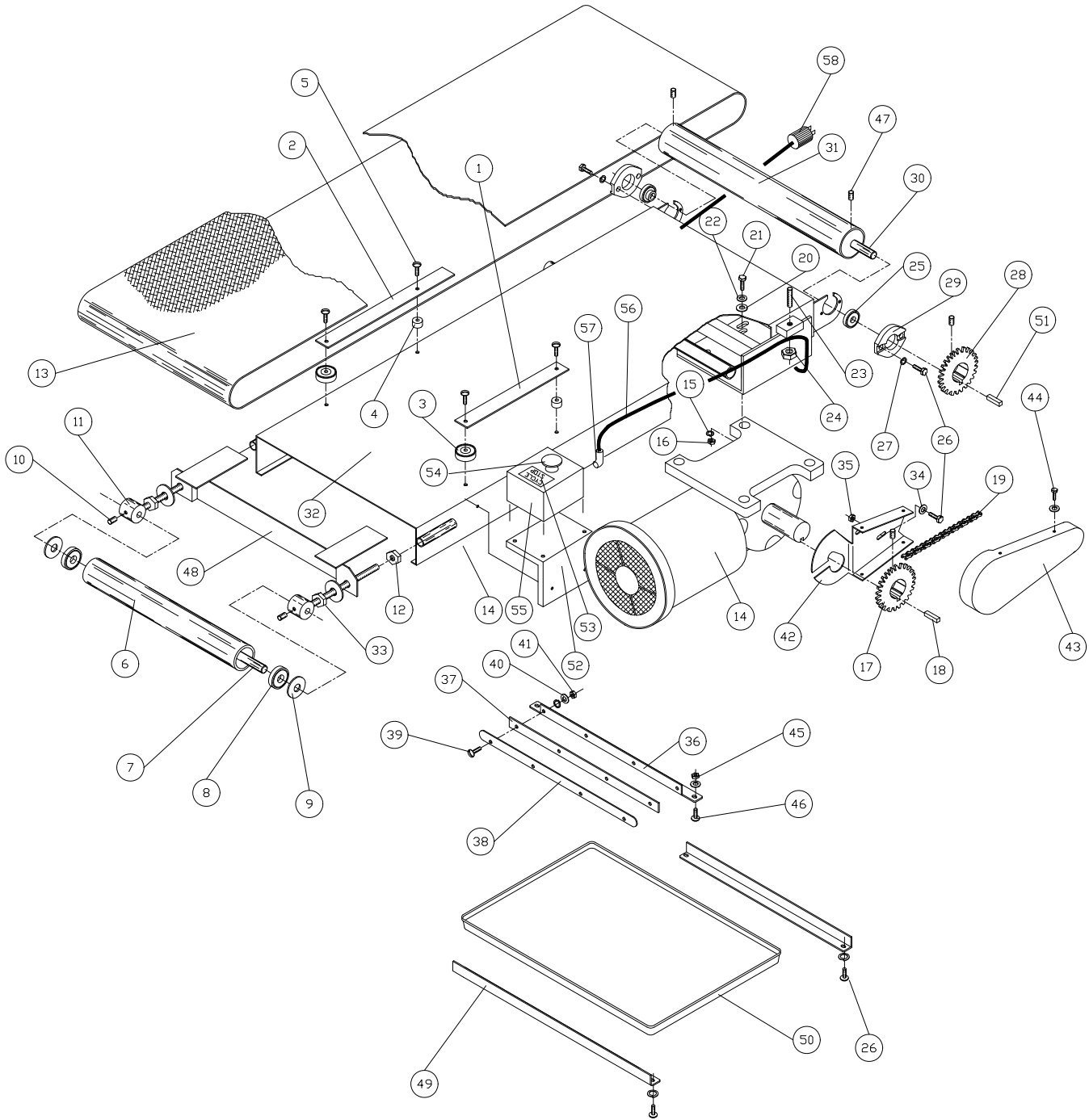

# CONVEYOR ASSEMBLY

ITEM	PART NO.	DESCRIPTION	NO. REQ'D
1	155RC	GUIDE BAR BELT TOP (SHORT)	1
2	156RC	GUIDE BAR BELT TOP (LONG)	1
3	641SC2	BEARING	2
4	103RC	SPACER	4
5	F9703TH	SCREW	7
6	105RC	ROLLER FRONT	1
7	106RC	SHAFT 5/8"	1
8	107RC	BALL BEARING (FRONT ROLLER)	2
9	F1000FWN	FLAT NYLON WASHER	4
10	F0502SS	SET SCREW	2
11	110RC	SUPPORT BEARING HOLDER	2
12	F1000NC	HEX NUT (BELT ADJUSTING)	4
13	112RC	BELT (LARGE CONVEYOR)	1
14	SS255	MOTOR 3/4 H.P. GEAR 100:1	1
15	F0600LW	LOCK WASHER	4
16	F0600NC	HEX NUT	4
17	K113LS	MOTOR SPROCKET 12T	1
18	118RC	KEY 3/16"	3
19	117RC	CHAIN	1
20	F0500FW (U.S.S.)	FLAT WASHER	4
21	F0606HH	BOLT	4
22	F0600FW	FLAT WASHER	4
23	F0812SDNP	STUD	2
24	F0800NC	HEX NUT	2
25	127RC	BALL BEARING (REAR ROLLER)	2
26	F0402HH	BOLT	8
27	F0400LW	LOCK WASHER	8
28	122RC	ROLLER SPROCKET 10T	1
29	126RC	FLANGE BEARING HOLDER	2
30	128RC	SHAFT 5/8"	1
31	129RC	ROLLER (COATED)	1
32	148RC	CONVEYOR FRAME	1
33	F1000HNC	HALF NUT	2
34	F0400FW	FLAT WASHER	1
35	F0400NC	NUT	1
36	133RC	SUPPORT BRACKET	1
37	152RC	PLASTIC STRIP	1
38	132RC	BELT SCRAPER	1
39	F9702TH	SCREW	4
40	F9700FW	FLAT WASHER	4
41	F9700NC	HEX NUT	4
42	141RC	CHAIN GUARD BRACKET (INNER)	1
43	143RC	CHAIN GUARD (OUTER)	1
44	F9701TH	SCREW	4
45	F0400NC	NUT	2
46	F0402TH	BOLT	2
47	F0502SS	SET SCREW	4
48	151RC	PINCH GUARD	1
49	154RC	CRUMB PAN SUPPORT	2
50	153RC	CRUMB PAN	1
51	F0404KY	KEY	1
52	157RC	CYCLE STOP MOUNT BRACKET	1
53	SS126	CYCLE STOP (NAME PLATE)	1
54	SS185	STOP BUTTON	1
55	SS336	ELECTRICAL ENCLOSURE	1
56	SS337	18-2 CORD	4
57	SS103	3/8" 90° CORD CONNECTOR	1
58	SS359	PLUG SINGLE PHASE	1

# PRESSURE PLATE & MOUNTING FRAME

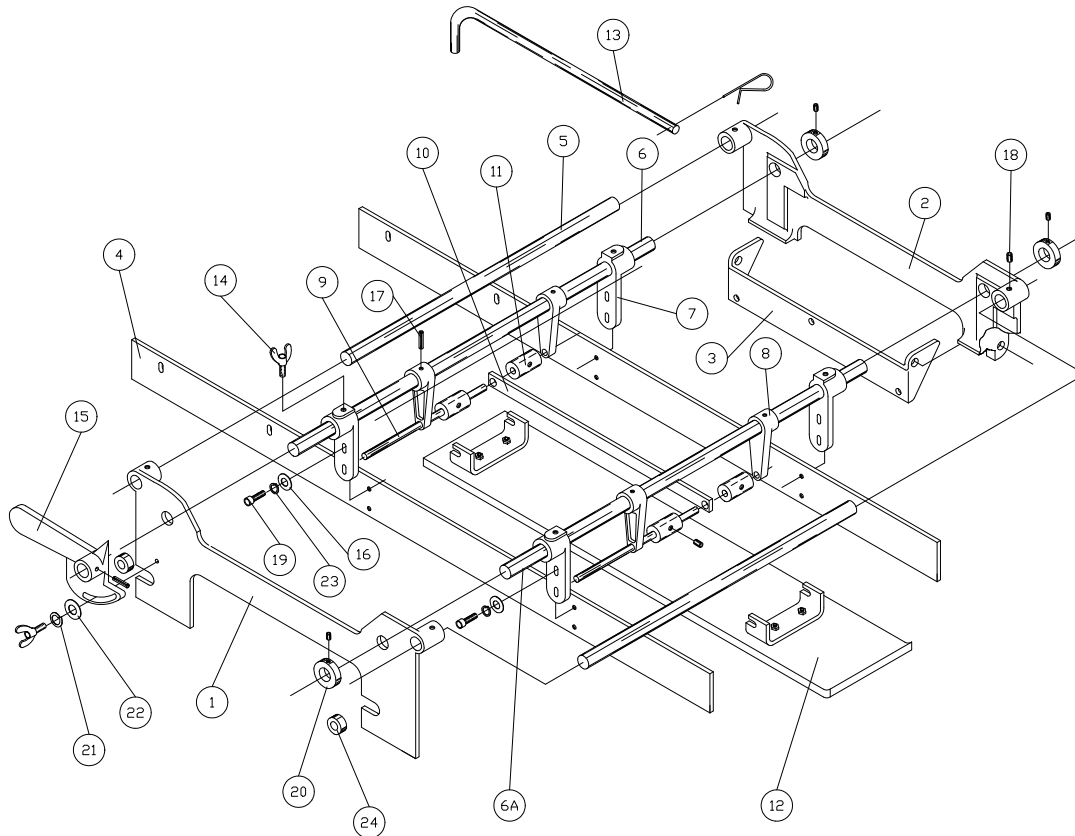

ITEM	PART NO.	DESCRIPTION	NO. REQ'D
1	MPP1	SIDE PLATE LOCKING	1
2	MPP2	SIDE PLATE PIVOTING	1
3	MPP3	HINGE BRACKET	1
4	MPP4	PRESSURE PLATE GUIDE BAR	2
5	MPP5	SPACER BAR	2
6	MPP6-1	PIVOT BAR (REAR)	1
6A	MPP6-2	PIVIOT BAR (FRONT)	1
7	MPP7	PRESSURE PLATE GUIDE BAR MOUNT	4
8	MPP8	PRESSURE PLATE PIVOT MOUNT	4
9	MPP9	PRESSURE PLATE MOUNTING ROD	2
10	MPP10	PIVOT SPACER BAR	1
11	MPP11	MOUNTING ROD SPACER	4
12	MPP12	PRESSURE PLATE - 6 INCH	1
13	MPP13	HINGE ROD	1
14	F0604WB	WING BOLT	5
15	MPP15	PIVOT LOCKING PLATE	1
16	F0400FW	FLAT WASHER	4
17	MPP17	ROLL PIN	8
18	F0502SS	SET SCREW	4
19	F0403SC	BOLT	8
20	MPP20	COLLAR LOCKING	3
21	F0600LW	LOCK WASHER	1
22	F0600FW	FLAT WASHER	1
23	F0400LW	LOCK WASHER	4
24	MPP25	SPACER	2



# DOUGH CENTERING EXTENSION ARM

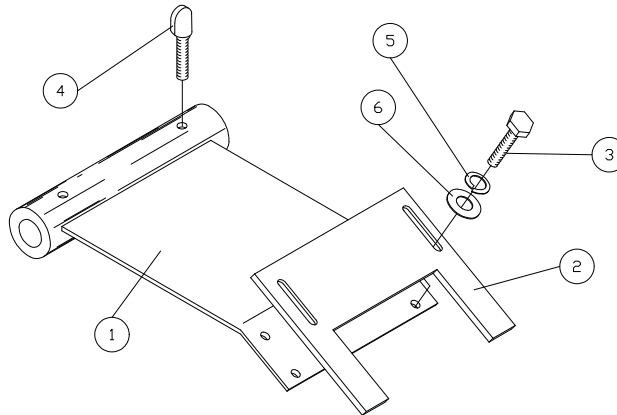

ITEM	PART NO.	DESCRIPTION	NO. REQ'D
1	MCA1	PIVOT BRACKET	1
2	MCA2	CENTERING BLOCK	1
3	F0403HH	BOLT	4
4	F0402TS	THUMB SCREW	2
5	F0400LW	LOCK WASHER	4
6	F0400FW	FLAT WASHER	4

# SECOND STAGE DIVIDER

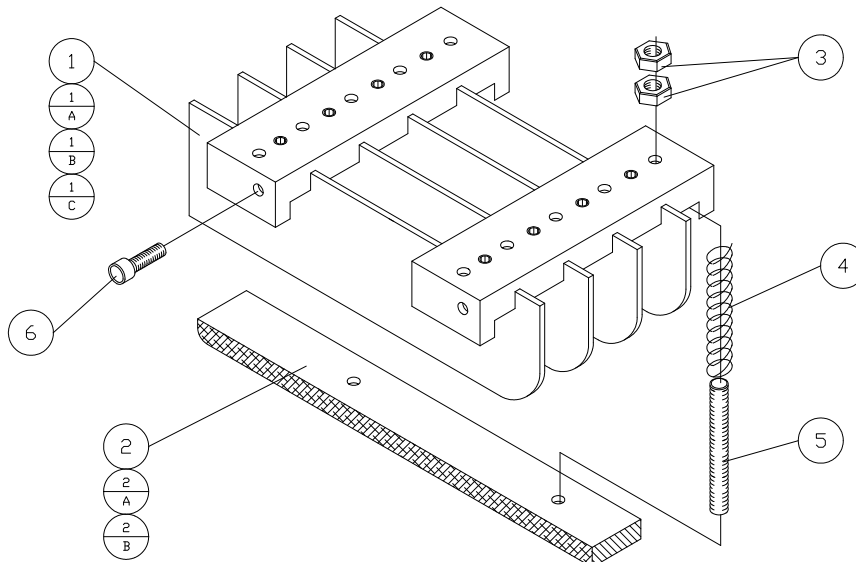

ITEM	PART NO.	DESCRIPTION	NO. REQ'D
1	MSD	SPACER PLATE - 2 SPACE	1
1A	MSD1	SPACER PLATE - 3 SPACE	1
1B	MSD2	SPACER PLATE - 4 SPACE	1
1C	MSD3	SPACER PLATE - 5 SPACE	1
2	MSD4	PLASTIC PRESSURE PLATE - 3 SPACE	3
2A	MSD5	PLASTIC PRESSURE PLATE - 4 SPACE	4
2B	MSD6	PLASTIC PRESSURE PLATE - 5 SPACE	5
3	F0400NC	HEX NUT	AS REQ'D
4	MSD9	SPRING	AS REQ'D
5	F0412SD	STUD	AS REQ'D
6	F0404SH	BOLT	4

# ELECTRICAL/SENSOR SYSTEM

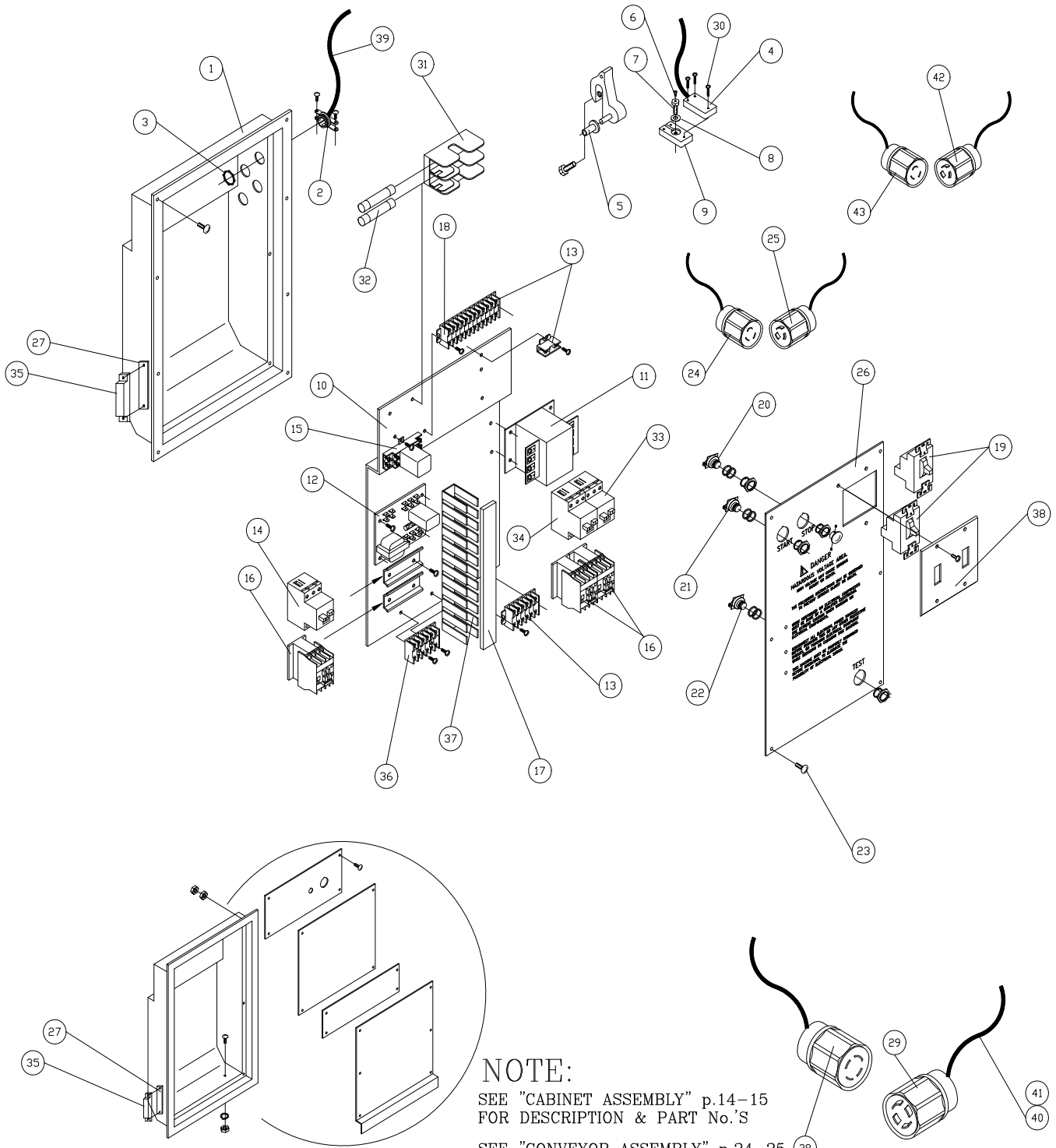

**NOTE:**

SEE "CABINET ASSEMBLY" p.14-15  
 FOR DESCRIPTION & PART No.'S

SEE "CONVEYOR ASSEMBLY" p.24-25  
 FOR DESCRIPTION & PART No.'S  
 OF CYCLE STOP BUTTON

## ELECTRICAL / SENSOR SYSTEM

ITEM	PART NO.	DESCRIPTION	NO. REQ'D
1	S617CA6	ELECTRICAL ENCLOSURE	1
2	SS100	ELECTRO LINE L-51 CONNECTOR w/ RETAINING NUT	3
3	SS101	STRAIN RELIEF RETAINING NUT	3
4	SS110-1	HOPPER TERMINATOR (TOP)	1
5	SS113	COVER HINGE INSULATOR	2
6	F9702TH	#8-32 TRUSS HD. SCREW	1
7	SS112	5/16-18 X 3/4 HEX BOLT	1
8	F0500FW	FLAT WASHER	1
9	SS110-2	HOPPER TERMINATOR (BOTTOM)	1
10	SS270	ELECTRICAL PANEL	1
11	SS176	CONTROL TRANSFORMER	1
12	SS179	SENSOR CONTROL UNIT	1
13	SS144	TERMINAL BLOCK	AS REQ'D
14	SS175	MOTOR PROTECTOR	1
15	SS180	AUXILIARY RELAY	1
16	SS169	MOTOR CONTACTOR	3
17	SS182	WIRING DUCT	1
18	SS145	SEGMENT, END, TERMINAL BLOCK	3
19	SS213	MANUAL STARTER	2
20	SS185	PUSH BUTTON (STOP)	2
21	SS184	PUSH BUTTON (START)	1
22	SS184A	HEAVY DUTY PUSH BUTTON (TEST)	1
23	F0402PH	SCREW	6
24	SS156	CONVEYOR MOTOR PLUG (FEMALE)	2
25	SS155	CONVEYOR MOTOR PLUG (MALE)	2
26	SS116	ELECTRICAL ENCLOSURE COVER PANEL	1
27	SS335	REED SWITCH MOUNT BLOCK	1
28	SS160	MOTOR PLUG (FEMALE)	1
29	SS159	OUTLET PLUG (MALE)	2
30	F9804RH	SCREW	3
31	SS133	FUSE HOLDER	1
32	SS240	2 AMP. FUSE	2
33	SS173	MOTOR PROTECTOR	1
34	SS172	MOTOR PROTECTOR	1
35	SS240	MAGNETIC REED SWITCH	3
36	SS143	TERMINAL BLOCK 6 POINT	1

**NOTE:**

GUARDS ARE INTERLOCKED, MACHINE WILL NOT OPERATE WITHOUT GUARDS IN PLACE.

# OILING SYSTEM

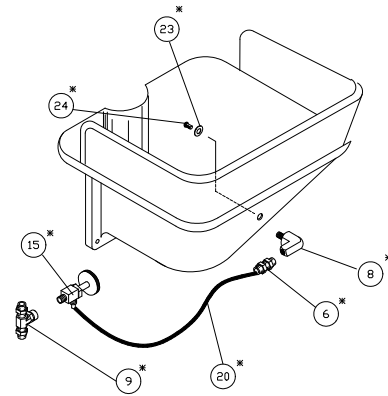
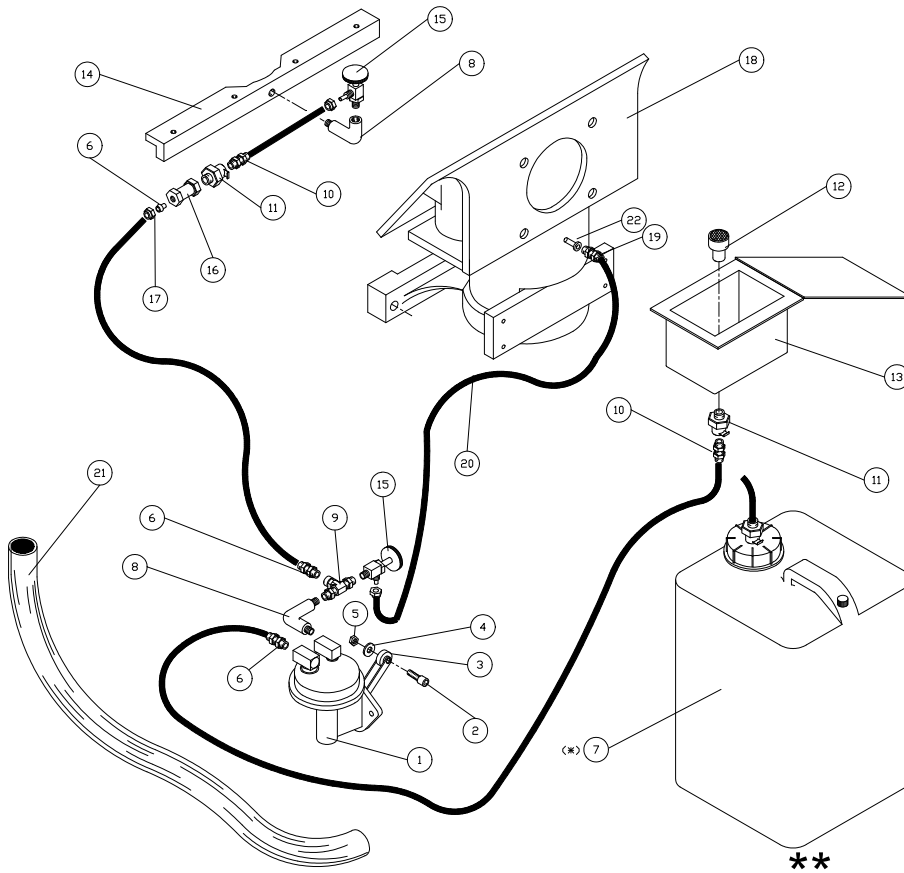

\* INDICATES PARTS  
 AVAILABLE WITH PART  
 NO. 445CDE EXTENDED  
 HOPPER (ONLY)

\*\* NOTE:  
 OPTIONAL EQUIPMENT

ITEM	PART NO.	DESCRIPTION	NO. REQ'D
1	716OS	OIL PUMP	1
2	F0403SH	BOLT	1
3	714OS	PUMP ROLLER BEARING	1
4	F0400LW	LOCK WASHER	1
5	F0400NC	HEX NUT	1
6	722OS	MALE CONNECTOR	3
**7	732OSA	EXTERNAL OIL TANK	1
8	724OS	STREET ELBOW 90°	2
9	725OS	STREET "T"	1
10	726OS	QUICK CONNECT, MALE	2
11	727OS	QUICK CONNECT, FEMALE	2
2	713OS	STRAINER W/ INSERT - FILTER ADAPTER	1
13	604CA	OIL BOX	1
14	S507MS/B	GIB BAR	1
15	704OS	VALVE	2
16	103-B-OZ	BRASS COUPLING	1
17	709OS	PLASTIC FERRULES	10
18	S0107CD	CYLINDER	1
19	708OS	MALE CHECK VALVE	1
20	710OS	1/4" OIL SYSTEM TUBING 12 FT.	12 FT.
21	711OS	1/2" OIL DRAIN TUBING 4 FT.	4 FT.
22	728OS	BRASS INSERT	1
23	F0400FW	STAINLESS STEEL FLAT WASHER	1
24	741OS	PLUG	1

# TROUBLESHOOTING



## DANGER

ALWAYS DISCONNECT ELECTRICAL POWER SOURCE WHEN MAINTAINING OR REPAIRING THIS MACHINE...

## NOTE:

GUARDS ARE INTERLOCKED, MACHINE WILL NOT OPERATE WITHOUT GUARDS IN PLACE.

THE OPERATION OF THE SCALE - O - MATIC DEPENDS ON VACUUM, FOR TOP PERFORMANCE. THIS CAN ONLY BE REALIZED IF ALL SEAL POINTS ARE IN PROPER ADJUSTMENT. THE FOLLOWING PLACES FOR POSSIBLE LOSS OF VACUUM ARE TO BE CHECKED:

1. PART NO. S0113CD GEAR  
 MAKE SURE MACHINE IS RUNNING IN THE RIGHT DIRECTION. SEE ARROW ON GEAR. GEAR MUST TURN CLOCKWISE.
  2. PART NO. 402CD-NEOPRENE "O" RING  
 CHECK FOR WEAR AND LOSS OF RESILIENCY.
  - \* 3. PART NO. 506MS-SLIDE PRESSURE STRIPS-POLYETHYLENE  
 CHECK FOR LOSS OF COMPRESSIBILITY.
  - \* 4. PART NO. 521MS SLIDE WEAR STRIP-NYLON  
 CHECK FOR WEAR.
  - \* 5. PART NO. 504MS GIB SCREWS  
 CHECK FOR SNUGNESS
  6. PART NO. 323PY PISTON RING  
 CHECK FOR WEAR-REPLACE IF WORN OR SCORED.
  7. PART NO. 503MS MEASURING CUP PLUNGER ROD GUIDE  
 CHECK FOR WEAR AND SMOOTHNESS OF OPERATION. IF WORN PART NO. 513MS WILL BIND OR STICK.
  8. PART NO. 513MS PLUNGER  
 CHECK FOR CIRCUMFERENCE WEAR, REPLACE IF DOUGHS BY-PASS INTO SPRING SECTION.
  9. PART NO. 434CD V-BELT DRIVE  
 KEEP BELT TIGHT TO AVOID SLIPPAGE.
  10. PART NO. 401CD SEAL SCRAPER RING  
 CHECK FOR WEAR AND FOR STRAIGHTNESS.
  11. PART NO. S0113CD GEAR  
 CLEAN CAM TRACK OCCASIONALLY. OBSERVE IF PART NO. 448CD (CAM TRACK SHOE) IS WORN, ALSO CHECK FOR WEAR ON GEAR CAM TRACK.
  12. PART NO. S507MS/B BRONZE GIB BAR  
 CHECK GIB BARS FOR WEAR AND EXCESSIVE PLAY BETWEEN DIVIDER SLIDE.
  13. PART NO. 704OS  
 CHECK TO SEE IF CLOGGED WITH DOUGH.
- \* ARE NON-CURRENT PARTS (OBSOLETE)  
 (SEE DETAIL "A")

\* \* GREASE ALL FITTINGS REGULARLY

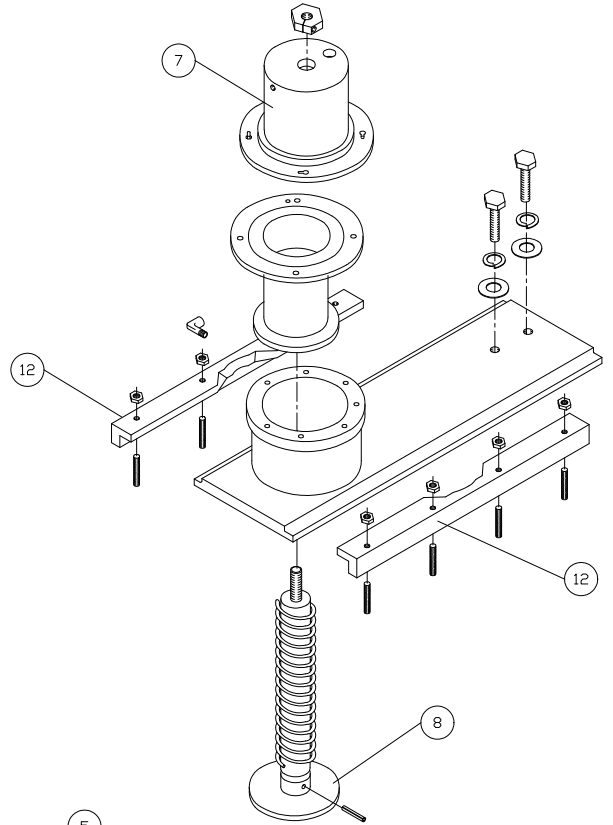
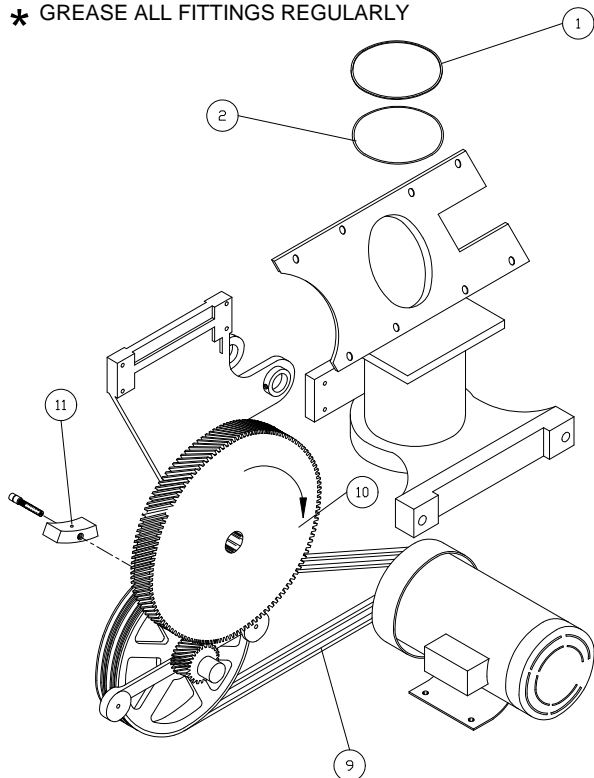

DETAIL 'A'  
 ASSEMBLY INSTRUCTIONS:

### ASSEMBLY INSTRUCTIONS:

- 1A. INSERT SPACER BAR OVER GIB BAR BOLTS FIRST.
- 2A. PLACE WEAR STRIP LINER (1/32" X 13" LG.) OVER SPACER BAR.
- 3A. PLACE PLASTIC WEAR STRIP (1/4" X 13" LG.) OVER LINER.
- 4A. NOW PLACE TOP & BOTTOM GIB BARS OVER PLASTIC WEAR STRIP AND SECURE WITH HEX BOLTS.

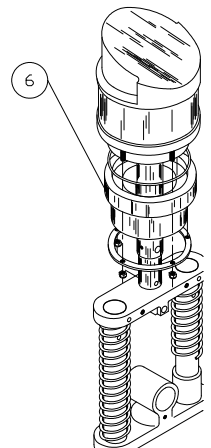

# ELECTRICAL (SCHEMATIC) (3) PHASE/230 VOLT

NOTE:  
 FUSE DISCONNECT OR CIRCUIT BREAKER  
 PROVIDED BY OTHERS PER (N.E.C. 430-53(C)).

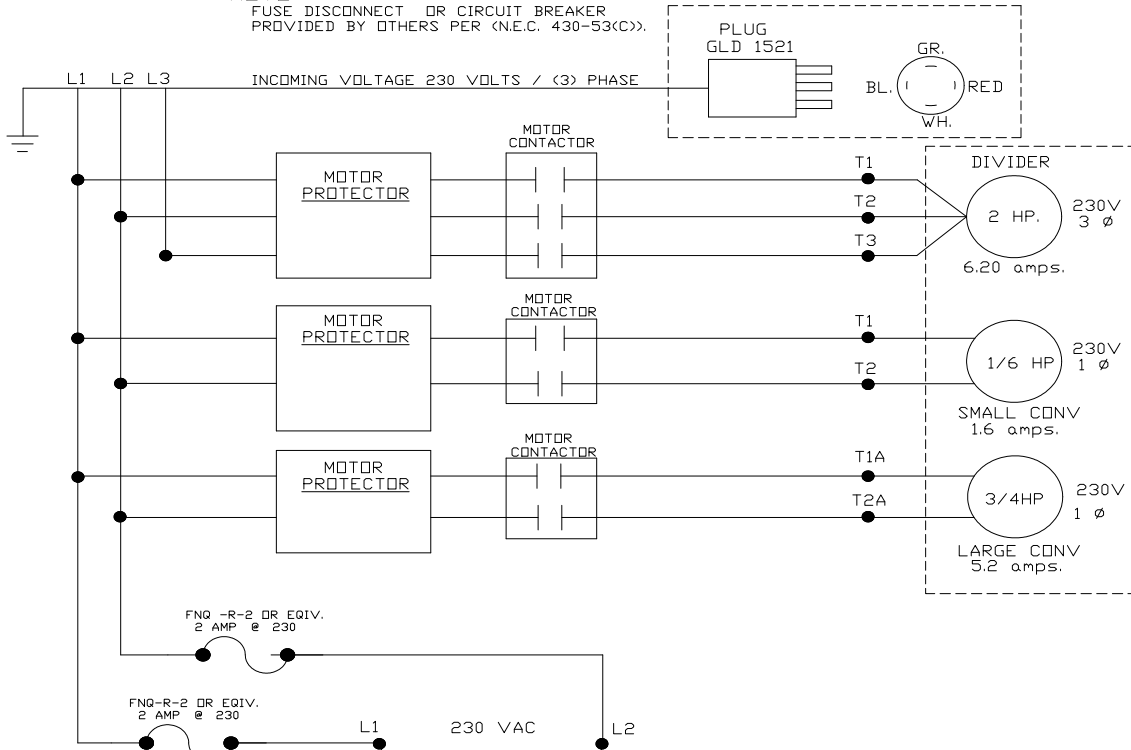

NOTE:  
 DASHED LINES REPRESENT ITEMS  
 EXTERNAL TO PANEL...

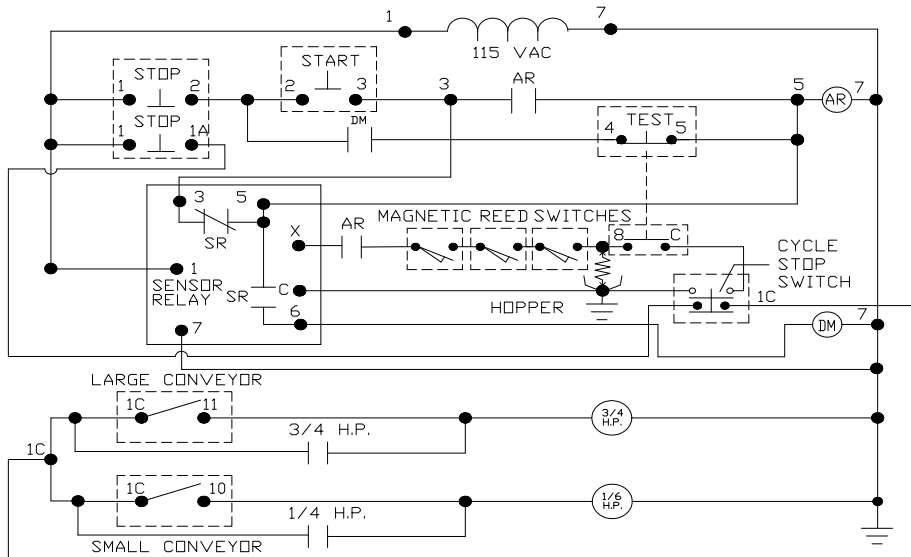

AR = AUX RELAY

SR = SENSOR RELAY

DM = DIVIDER MOTOR CONTACTOR

# ELECTRICAL (HARDWIRE) (3) PHASE/230 VOLT

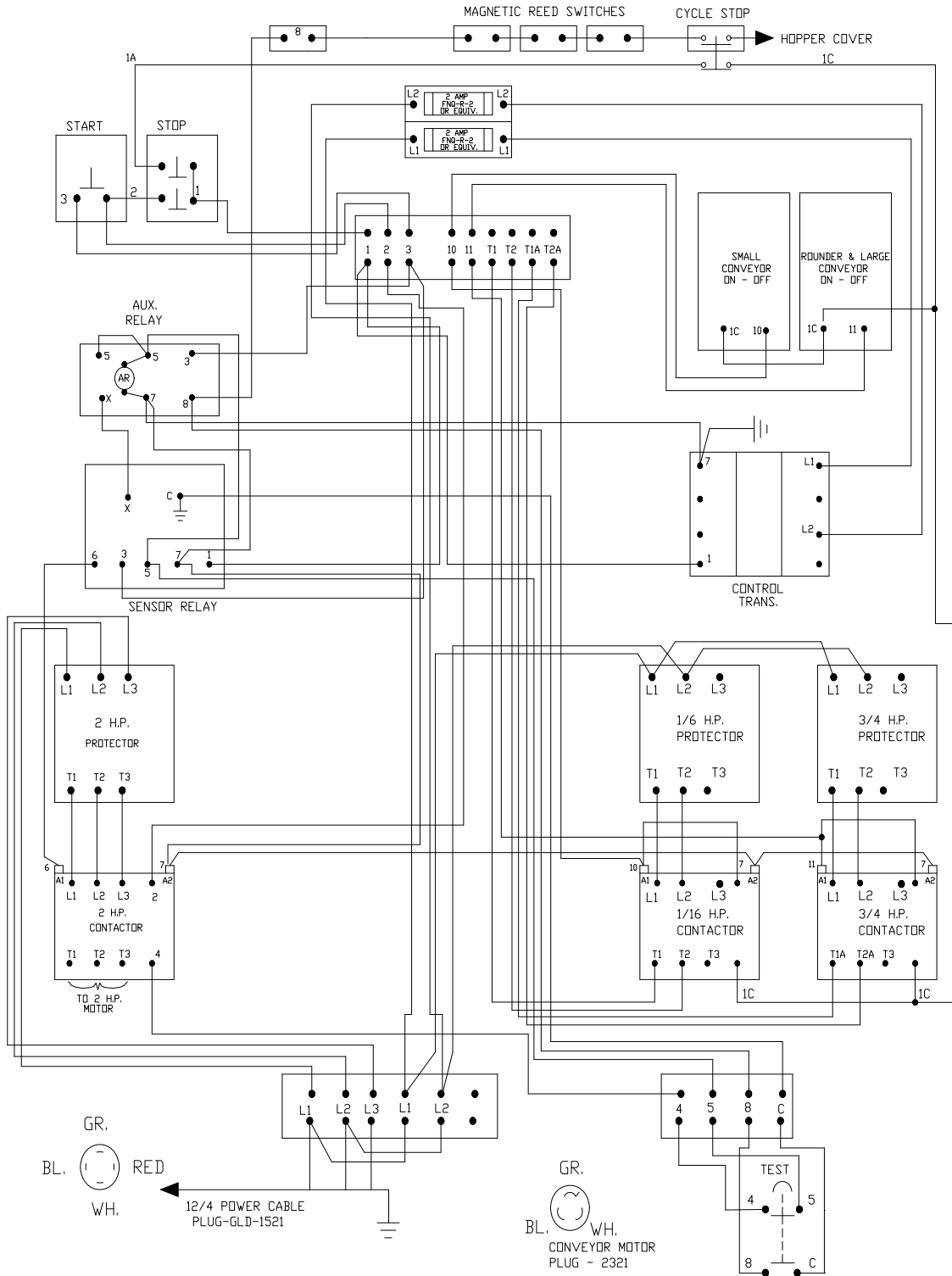



# ELECTRICAL (HARDWIRE) (3) PHASE/208 VOLT

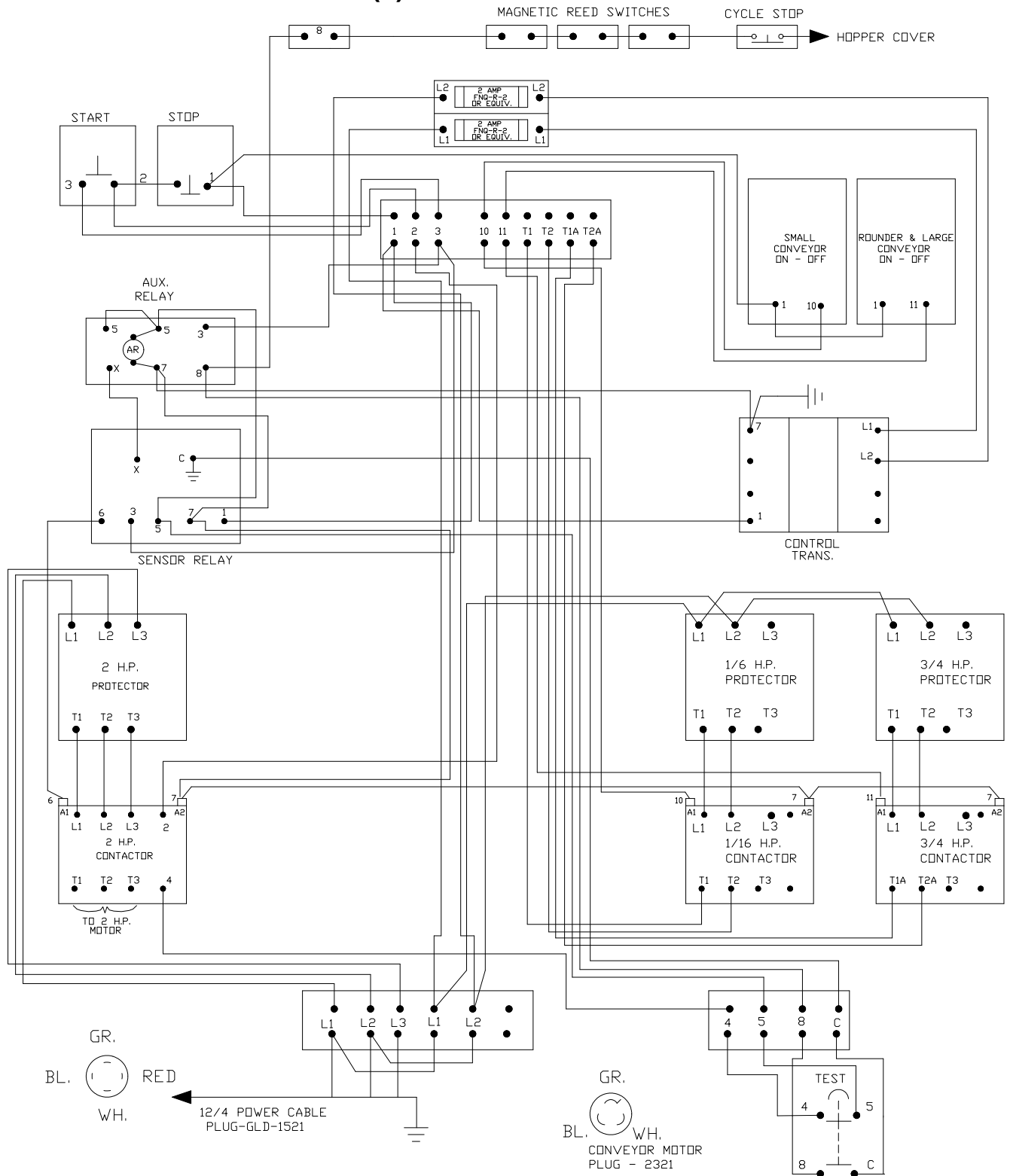

# ORDERING REPLACEMENT PARTS

**IMPORTANT:**

**ONLY USE FACTORY SUPPLIED REPLACEMENT PARTS TO MAINTAIN MACHINE SAFETY, PERFORMANCE AND SANITARY CONDITIONS.**

**USE OF NON-APPROVED PARTS MAY VOID MANUFACTURES WARRANTY.**

**TO ORDER REPLACEMENT PARTS ALWAYS:**

- 1) CHECK THE MACHINE TOP IDENTIFY MISSING, DAMAGED OR NON-FUNCTIONAL PARTS INCLUDING GUARDS, WARNING LABELS AND INSTRUCTIONS.
- 2) COMPARE THE LIST WITH THE PARTS DIAGRAMS SUPPLIED.
- 3) RECORD THE COMPLETE MODEL AND SERIAL NUMBER OF THE UNIT.
- 4) CALL A.M. MANUFACTURING (800) 342-6744 AND PROVIDE ALL INFORMATION NOTED ABOVE TO EXPEDITE ORDER PROCESSING AND HELP REDUCE SHIPPING COST.
- 5) PROVIDE COMPLETE DETAILS FOR (SHIP TO) AND (BILL TO) INFORMATION. TO ASSIST PROMPT DELIVERY, SPECIFY TYPE OF CARRIER PREFERRED IN SHIPMENT.
- 6) ALL MAJOR CREDIT CARDS ACCEPTED.

