

THE ATWOOD ROTARY KNIFE DIVIDER

AUTOMATIC BAGEL DIVIDING

MODEL: RK2201 SERIES II

INCLUDES: RK2200 SERIES MACHINES

OPERATIONS AND SAFETY MANUAL

INCLUDING PARTS CATALOG
AND MAINTENANCE INSTRUCTIONS

MODEL No. _____

SERIAL No. _____



CAUTION:

DO NOT OPERATE, CLEAN OR SERVICE THIS MACHINE BEFORE YOU READ THIS MANUAL, AND ARE FAMILIAR WITH THE SAFETY INSTRUCTIONS IN THIS MANUAL AND THOSE ON THE LABELS ON THE MACHINE. KEEP THIS MANUAL AND OTHER MATERIALS DELIVERED WITH THE MACHINE, ACCESSIBLE TO THE OPERATORS FOR EASY REFERENCE DURING USE.

THE ENTIRE CONTENTS OF THIS PUBLICATION ARE COPYRIGHTED AND ALL RIGHTS ARE RESERVED. REPRODUCTION IN WHOLE OR IN PART IS PROHIBITED WITHOUT WRITTEN PERMISSION OF A.M. MFG. INC.

IF YOU SHOULD HAVE ANY (?)
QUESTIONS ABOUT GUARDS OR
PLACEMENT CALL (708) 841-0959.

THIS CATALOG BECOMES OBSOLETE ON
12/31/00. UPDATED CATALOGS ARE AVAILABLE
DIRECTLY FROM A.M. MFG. INC.



MANUFACTURING COMPANY

DIVISION OF THE ATWOOD CORPORATION
14151 IRVING AVENUE DOLTON, ILLINOIS 60419

(773) 785-3177 (708) 841-0959 (800) 342-6744 FAX: (708) 841-0975 www.ammfg.com

OWNERS RESPONSIBILITY

NOTE:

THE PARTS AND EQUIPMENT DESCRIBED IN THIS MANUAL MAY BE COVERED BY ONE OR MORE U.S. AND FOREIGN PENDING PATENTS.



TO MAINTAIN MACHINE AND USER SAFETY, THE RESPONSIBILITY OF THE OWNER IS TO READ AND FOLLOW THESE INSTRUCTIONS AND TO ENSURE THAT ALL OPERATORS UNDERSTAND AND FOLLOW THESE AND OTHER SAFETY INSTRUCTIONS IN THIS MANUAL.

- FOLLOW ALL INSTALLATION INSTRUCTIONS.
- MAKE SURE INSTALLATION CONFORMS TO ALL APPLICABLE LOCAL, STATE, AND FEDERAL CODES, RULES AND REGULATIONS SUCH AS STATE AND FEDERAL OSHA REGULATIONS AND ELECTRICAL CODES.
- CAREFULLY CHECK THE UNIT FOR CORRECT INITIAL FUNCTION.
- READ AND FOLLOW THE SAFETY INSTRUCTIONS. KEEP THEM READILY AVAILABLE FOR MACHINE OPERATORS.
- MAKE CERTAIN ALL OPERATORS ARE PROPERLY TRAINED, KNOW HOW TO SAFELY AND CORRECTLY OPERATE THE UNIT AND ARE PROPERLY SUPERVISED.
- ALLOW UNIT OPERATION ONLY WITH ALL PARTS INCLUDING SAFETY EQUIPMENT, IN PLACE AND OPERATING SAFELY.
- CAREFULLY INSPECT THE UNIT ON A REGULAR BASIS AND PERFORM ALL MAINTENANCE AS REQUIRED.
- SERVICE AND MAINTAIN THE UNIT ONLY WITH AUTHORIZED OR APPROVED REPLACEMENT PARTS.
- KEEP ALL INSTRUCTIONS PERMANENTLY WITH THE UNIT ALONG WITH ALL DECALS AND WARNING LABELS ON THE UNIT CLEAN AND VISIBLE.

TABLE OF CONTENTS

	<u>PAGE</u>
OWNERS RESPONSIBILITIES	INSIDE COVER
INTRODUCTION & SPECIFICATIONS & INSTALLATION	2
SAFETY SIGNAL WORDS	3
LOCATION OF WARNING LABELS	4
REPRODUCTION OF WARNING LABELS	5
GENERAL SAFETY INFORMATION / SAFETY RULES	6
OPERATING INSTRUCTIONS	7
GUIDE TO CLEANING	8
GUIDE TO MAINTENANCE	9-10
BELT REPLACEMENT	11-12
<u>PARTS CATALOG</u>	13
INFEED CONVEYOR ASSEMBLY	14
DISCHARGE CONVEYOR ASSEMBLY	15
CABINET ASSEMBLY	16-17
ROLLER ASSEMBLY	18-19
LEFT SIDE ASSEMBLY	20-21
RIGHT SIDE ASSEMBLY	22-23
ELECTRICAL SYSTEM	24-25
ELECTRICAL (SCHEMATIC 208 / 230 VOLTS (2201))	26
ELECTRICAL (HARDWIRE 208 / 230 VOLTS (2201))	27
ELECTRICAL (SCHEMATIC 208 / 230 VOLTS (2201))	28
ELECTRICAL (HARDWIRE 208 / 230 VOLTS (2201))	29
ELECTRICAL (HARDWIRE (RECTIFIER BLOCK (2201))	30
ORDERING REPLACEMENT PARTS	31
NOTES	32

IMPORTANT:

A.M. MANUFACTURING Co. RESERVES THE RIGHT TO MAKE CHANGES IN DESIGN, SPECIFICATIONS OR MANUFACTURING. TO IMPROVE THEIR PRODUCTS WITHOUT NOTICE AND WITHOUT OBLIGATION TO CHANGE OR IMPROVE PREVIOUSLY BUILT PRODUCTS INCLUDING MANUALS AND CATALOGS.

ONLY USE FACTORY SUPPLIED REPLACEMENT PARTS TO MAINTAIN MACHINE SAFETY, PERFORMANCE AND SANITARY CONDITIONS. USE OF NON-APPROVED PARTS MAY VOID MANUFACTURERS WARRANTY.

KNOW YOUR UNIT. COMPARE DIAGRAMS IN THIS MANUAL WITH THE UNIT BEFORE STARTING SERVICE, TO OBTAIN MAXIMUM SAFETY AND PERFORMANCE.

TO ORDER REPLACEMENT PARTS:
TURN TO PAGE 31 OF THIS MANUAL.



WARNING:

THIS MANUAL CONTAINS CRITICAL SAFETY INSTRUCTIONS. READ AND FOLLOW THEM CAREFULLY. FAILURE TO FOLLOW WARNING AND INSTRUCTIONS MAY LEAD TO SERIOUS PERSONAL INJURY. THE OWNER IS RESPONSIBLE FOR MAINTAINING THE UNIT, ITS INSTRUCTIONS AND DECALS FOR OPERATION REFERENCE. FOR ADDITIONAL COPIES CONTACT A.M. MANUFACTURING: (800) 342-6744

OPERATIONS AND SAFETY MANUAL INCLUDING PARTS CATALOG

**READ AND FAMILIARIZE YOURSELF WITH THIS MANUAL BEFORE OPERATING THIS MACHINE
FOLLOW INSTRUCTIONS DURING USE**

INTRODUCTION

THE MODEL RK-2201 FROM A.M. MANUFACTURING IS A SINGLE BANK, ROTATING KNIFE DIVIDER. IT CAN ACHIEVE OUTPUT SPEEDS OF UP TO 4800 PIECES PER HOUR (DEPENDING ON SIZE), ALLOWING GREATER BAGEL PRODUCTION. IT'S VERSATILE YET SIMPLE DESIGN MAKE IT BOTH LABOR SAVING AND COST EFFECTIVE. STUDY THIS OPERATION AND SAFETY MANUAL FOR FULL BENEFITS.



CAUTION:

ALL OPERATORS MUST BE FULLY TRAINED AND INSTRUCTED IN SAFETY PROCEDURES BEFORE BEGINNING PRODUCTION.

SPECIFICATIONS

PRODUCTION RATE	225 TO 400 DOZEN PER HOUR (DEPENDING ON SIZE)
HEIGHT	64"
LENGTH	71" (WITH STANDARD INFEEED CONVEYOR)
WIDTH	18 1/2"
SHIPPING WEIGHT	500 lbs.
STANDARD INFEEED CONVEYOR LENGTH	48"
HEIGHT OF INFEEED CONVEYOR LENGTH	37" (TO BOTTOM OF CONVEYOR)
ELECTRICAL REQUIREMENTS	208/220 VOLT - SINGLE PHASE (1 H.P. DIVIDER MOTOR)

ALL MOVING PARTS, WITH EXCEPTION OF NECESSARY CONVEYING SURFACES ARE COVERED AND GUARDED...

INSTALLATION INSTRUCTIONS

LOCATION:

SELECT LOCATION CAREFULLY. THE AREA SHOULD PROVIDE THE OPERATOR WITH ENOUGH SPACE TO USE THE EQUIPMENT IN A SAFE MANNER. THE FLOOR AREA SELECTED SHOULD BE EASY TO CLEAN AND SHOULD BE FREE OF OIL, GREASE, ETC. AVOID AREAS WHERE BYSTANDERS AND CUSTOMERS MAY BE PRESENT.



CAUTION

PROPER UNIT INSTALLATION IS NECESSARY FOR SAFE AND EFFICIENT OPERATION. PROPER INSTALLATION ALSO HELPS PROTECT THE UNIT FROM DAMAGE AND MAKES SERVICE EASIER.

SAFETY

THIS MACHINE IS DESIGNED TO PROVIDE FOR SAFE OPERATION IF NORMAL OPERATING PROCEDURES AND SAFETY MESSAGES LOCATED ON THE MACHINE AND IN THIS MANUAL ARE FOLLOWED.



THIS IS A SAFETY ALERT SYMBOL. YOU WILL FIND IT ON VARIOUS SAFETY LABELS ON THE MACHINE AND IT WILL ALSO APPEAR IN THIS MANUAL WHEREVER SAFETY MESSAGES ARE GIVEN.

GET FAMILIAR WITH SIGNAL WORDS:

CAUTION, WARNING & DANGER

CAUTION:

INDICATES A POTENTIALLY HAZARDOUS SITUATION WHICH, IF NOT AVOIDED, MAY RESULT IN MINOR OR MODERATE INJURY. IT MAY ALSO BE USED TO ALERT AGAINST UNSAFE PRACTICES.

WARNING:

INDICATES A POTENTIALLY HAZARDOUS SITUATION WHICH, IF NOT AVOIDED, COULD RESULT IN DEATH OR SERIOUS INJURY.

DANGER:

INDICATES AN IMMINENTLY HAZARDOUS SITUATION WHICH, IF NOT AVOIDED, WILL RESULT IN DEATH OR SERIOUS INJURY. THIS SIGNAL WORD IS TO BE LIMITED TO THE MOST EXTREME SITUATIONS.

NOTE:

A NOTE PROVIDES KEY INFORMATION TO MAKE PROCEDURES EASIER AND CLEARER.

TYPICAL WARNING LOCATIONS

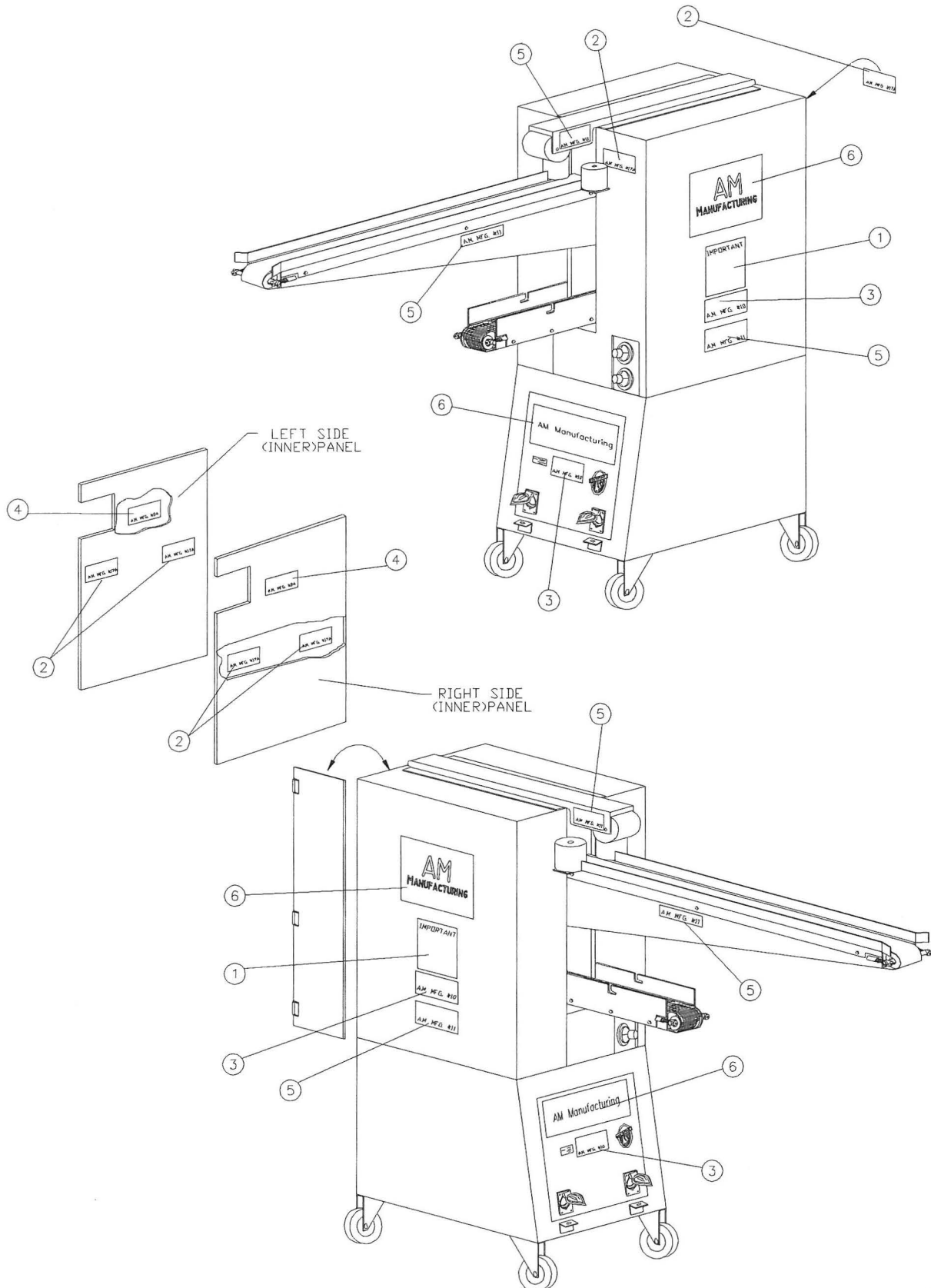

WARNING LABELS

PART NO. AM MFG. # 21 (1)

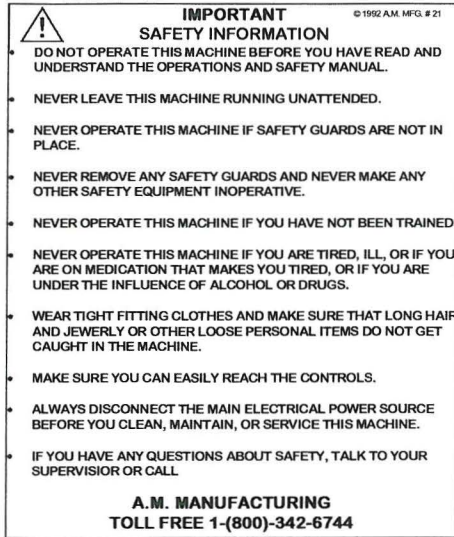

LEFT SIDE / RIGHT SIDE
 CABINET CASE

PART NO. AM MFG. # 24 (4)



LEFT / RIGHT OUTSIDE PANELS ON
 SPROCKET SIDES OF PANEL

PART NO. AM MFG # 11 (5)



LEFT SIDE / RIGHT SIDE CABINET CASE
 LEFT SIDE / RIGHT SIDE INFEED CONVEYOR
 LEFT SIDE / RIGHT SIDE TOP COVER GUARD

NOTE:

MACHINE DESIGN AND SPECIFICATIONS MAY VARY. ACTUAL LABEL DESIGN AND PLACEMENT SUBJECT TO CHANGE WITHOUT NOTICE AND MAY VARY FROM THIS ILLUSTRATION.

(2) PART NO. AM MFG. #17A

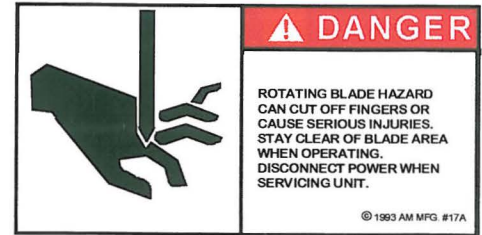

RIGHT FRONT & REAR SIDE OF CABINET CASE
 LEFT SIDE / RIGHT SIDE (INNER PANELS)
 ABOVE DISCHARGE CONVEYOR

(3) PART NO. AM MFG. # 10



FRONT ELECTRICAL PANEL
 LEFT SIDE / RIGHT SIDE CABINET CASE

(6) PART NO. AM MFG. # 33



LEFT SIDE / RIGHT SIDE CABINET CASE
 FRONT ELECTRICAL PANEL

CAUTION:

IF ANY SAFETY LABELS ARE MISSING, THEY **MUST BE REPLACED!** CONTACT YOUR DEALER OR A.M. MFG. FOR REPLACEMENT.

SAFETY RULES



IMPORTANT:

READ AND FOLLOW THESE SAFETY RULES. THEY ARE FOR YOUR PROTECTION AND THE PROTECTION OF THOSE WORKING WITH YOU.

- DO NOT OPERATE THIS MACHINE BEFORE YOU READ AND UNDERSTAND THE OPERATIONS AND SAFETY MANUAL.
- FOLLOW ALL INSTRUCTIONS DURING USE OF THIS MACHINE.
- LEAVE ALL GUARDS IN PLACE. INSTALL ALL GUARDS IF THEY WERE REMOVED FOR CLEANING, MAINTENANCE, REPAIR OR OTHER REASONS.
- NEVER OPERATE THE MACHINE IF YOU HAVE NOT BEEN TRAINED TO OPERATE THE MACHINE PROPERLY.
- NEVER OPERATE THE MACHINE IF YOU ARE TIRED, ILL, ON MEDICATION, OR UNDER THE INFLUENCE OF ALCOHOL OR DRUGS.
- WEAR TIGHT FITTING CLOTHES. MAKE SURE THAT LONG HAIR, JEWELRY, OR LOOSE PERSONAL ITEMS ARE SECURED SO THEY CANNOT GET CAUGHT IN THE MACHINE. THIS CAN LEAD TO SERIOUS INJURIES.
- MAKE SURE YOU CAN EASILY REACH ALL CONTROLS. IF NOT, A STABLE AND SAFE ELEVATED PLATFORM OR OTHER WORK-AID MUST BE PROVIDED.
- ALWAYS DISCONNECT THE MAIN ELECTRICAL POWER SOURCE BEFORE CLEANING, IF MAINTENANCE OR SERVICE IS PERFORMED, OR IF THE MACHINE IS OUT OF SERVICE.
- NEVER CLEAN BELTS ON MACHINE, ALWAYS REMOVE BELT FROM MACHINE TO CLEAN OR SERVICE (WHEN APPLICABLE).
- NEVER LEAVE THIS MACHINE RUNNING UNATTENDED.
- GUARDS ARE INTERLOCKED, MACHINE WILL NOT OPERATE WITHOUT GUARDS IN PLACE.

IMPORTANT:

IF YOU HAVE ANY QUESTIONS ABOUT THESE SAFETY RULES, SEE YOUR SUPERVISOR OR CALL A.M. MANUFACTURING Co. TOLL FREE: (800)342-6744

OPERATING INSTRUCTIONS



WARNING:

UNIT MUST BE PROPERLY OPERATED AND MAINTAINED TO PREVENT MACHINE DAMAGE OR PERSONAL INJURY. REVIEW INSTRUCTIONS WITH ALL EMPLOYEES BEFORE USE.



CAUTION:

MAGNETIC REED SWITCH (PART NO. SS240).

THESE PARTS ARE LOCATED ON (3) THREE AREAS OF THE MACHINE, AS DESCRIBED ON PAGES 16, 17 & 25. THE LOCATIONS ARE AS FOLLOWS: RIGHT AND LEFT SIDES OF BASE CABINET FRAME, INSIDE RIGHT AND LEFT SIDE CASES / BASE OF REAR CABINET DOOR AND FRAME.

THESE SWITCHES ARE LOCATED AT POINTS ON THE MACHINE WHERE EASY ACCESS IS KNOWN. IF THE CONTACT BETWEEN THE (2) TWO REED SWITCHES ARE BROKEN OR DISRUPTED IN ANY WAY, THIS WILL AUTOMATICALLY DISCONNECT POWER TO THE MACHINE AND THE MACHINE WILL NOT RUN. TO AVOID THIS PROBLEM, LEAVE SIDE PANELS ON THE MACHINE AND KEEP REAR DOOR CLOSED AT ALL TIMES WHILE MACHINE IS RUNNING.

I. PRELIMINARY START-UP PROCEDURE

- A. PLUG POWER CORD INTO PROPER RECEPTACLE.
- B. INSPECT MACHINE FOR ANY DAMAGES.

II. OPERATING OF THE DIVIDER

- A. SET WEIGHT AND SPEED CONTROLS TO 50% (SEE FIGURE 2).
- B. HAVE YOUR DOUGH READY NEXT TO MACHINE AND COVER TO AVOID SURFACE SKIN. THIS CAN CAUSE DOUGH TO SLIDE THROUGH FORMER.
- C. HAVE DOUGH ALREADY CUT INTO STRIPS OF APPROXIMATELY 3" DIAMETER, BY A MAXIMUM OF 4 FT. LONG. MAKE SURE THERE IS ABOUT 1/4" OF SPACE BETWEEN THE STRIPS OF DOUGH AND THE SIDE WALLS OF THE CONVEYOR, SO DOUGH DOES NOT CATCH AND BIND.
- D. REPEAT STEP 3 AND REPEAT PROCESS.

NOTE:

FOR MORE ACCURATE RESULTS MAKE SURE THE STRIPS CUT WILL BE PLACED SO THAT THE END OF THE FRONT STRIP IS OVERLAPPING BY THE FRONT OF THE TRAILING STRIP. SEE FIGURE 1.

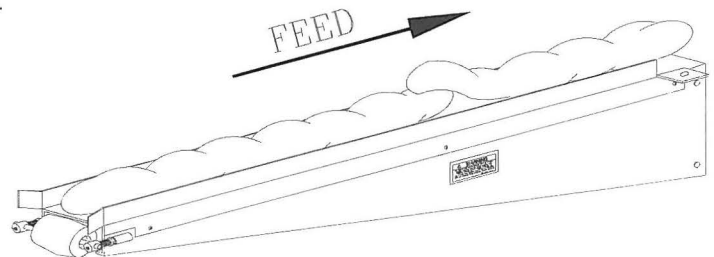

FIGURE 1

KNIFE
(SPEED
CONTROL)

THE SPEED CONTROL: TURNING THIS SWITCH CLOCKWISE (C.W.) INCREASES PRODUCTION RATE; TURNING IT COUNTER CLOCKWISE (C.C.W.) DECREASES PRODUCTION RATE. SEE FIGURE 2.

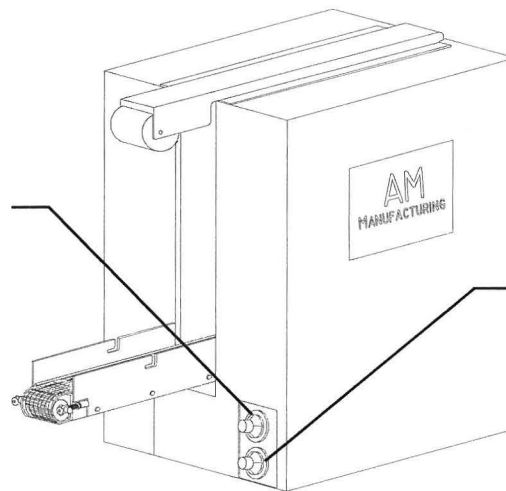

FIGURE 2

DRUM
(WEIGHT CONTROL)

THE WEIGHT CONTROL: TURNING THIS SWITCH CLOCKWISE (C.W.) INCREASES WEIGHT; TURNING IT COUNTER-CLOCKWISE (C.C.W.) DECREASES THE WEIGHT. SEE FIGURE 2.

CLEANING PROCEDURES

THESE PROCEDURES ARE VERY IMPORTANT TO MAINTAIN PRODUCT QUALITY AND MACHINE PERFORMANCE.

A MESSAGE FROM THE MANUFACTURER:

ALL A.M. MANUFACTURING MACHINE ARE TESTED WITH DOUGH DURING THE IN-HOUSE RUN-IN AND QUALITY AUDIT PROCEDURE. ALTHOUGH THE MACHINE HAS BEEN CLEANED, SOME EVIDENCE OF DOUGH ON AND IN THE MACHINE MAY BE DETECTED. THIS IS NORMAL.

I. DIVIDER



1. **CAUTION: ALWAYS DISCONNECT ELECTRICAL POWER SOURCE WHEN CLEANING, MAINTAINING OR REPAIRING THIS MACHINE..**
2. USING A SOAP SOLUTION WIPE DOWN OUTSIDE OF CABINET TO EXPOSE ALL WARNING LABELS TO ALERT ALL EMPLOYEES OF ANY POSSIBLE HAZARDS.



WARNING: CONVEYOR MAINTENANCE SHALL BE PERFORMED ONLY WHEN CONVEYOR IS STOPPED, AND ALL POWER IS OFF AND LOCKED OUT.

3. CONTINUE TO WIPE DOWN BOTH CONVEYORS ENTIRELY. THIS IS TO REMOVE ANY DOUGH BUILD - UP THAT OCCURS UNDER THE BELTS AND ON THE INTERIOR WALLS OF THE CONVEYORS.

NOTE: THIS ALSO HELPS PREVENT BELT SLIPPAGE THAT MAY OCCUR.

4. OPEN REAR INSPECTION DOOR.
5. USING A SOAP SOLUTION, WIPE DOWN THE DRUM SCRAPER AND KNIFE FROM THE EXCESS DOUGH BUILD - UP THAT OCCURS.

NOTE:

YOU MAY HAVE TO ACTUALLY SCRAPE SOME DOUGH FROM THE DRUM SCRAPER AND KNIFE BY HAND TO THOROUGHLY CLEAN THESE COMPONENTS.



PRACTICE SAFETY FIRST:

ALWAYS DISCONNECT ELECTRICAL SERVICE WHEN CLEANING OR MAINTAINING THIS MACHINE, THUS AVOIDING CHANCE OF SERIOUS INJURIES. MACHINES ARE NOT DANGEROUS IF COMMON SENSE IS APPLIED AND THE INSTRUCTIONS ARE CAREFULLY FOLLOWED. THINK AND PRACTICE SAFETY FIRST.

MAINTENANCE PROCEDURES

THESE PROCEDURES ARE VERY IMPORTANT TO MAINTAIN PRODUCT QUALITY AND MACHINE PERFORMANCE...



PRACTICE SAFETY FIRST

ALWAYS DISCONNECT ELECTRICAL SERVICE WHEN CLEANING OR MAINTAINING THIS MACHINE, THUS AVOIDING CHANCE OF SERIOUS INJURIES. MACHINES ARE NOT DANGEROUS IF COMMON SENSE IS APPLIED AND THAT THE INSTRUCTIONS ARE CAREFULLY FOLLOWED. THINK AND PRACTICE SAFETY FIRST.

READ AND FOLLOW MAINTENANCE INSTRUCTIONS BELOW TO HELP KEEP THE UNIT IN GOOD OPERATING CONDITION. REFER TO OTHER MATERIALS RECEIVED WITH THE UNIT AND TO SERVICE AND SAFETY BULLETINS FROM THE MANUFACTURER FOR ADDITIONAL INSTRUCTIONS FOR PROPER MAINTENANCE AND SERVICE. REGULAR INSPECTIONS AND PROPER MAINTENANCE ARE ESSENTIAL TO HELP PREVENT ACCIDENTS AND INJURIES.

I. DIVIDER



DANGER: ALWAYS DISCONNECT ELECTRICAL POWER SOURCE WHEN CLEANING, MAINTAINING OR REPAIRING THIS MACHINE...



WARNING: BEFORE MAKING ANY INSPECTION, ADJUSTMENT OR REPAIR, BE CERTAIN POWER SOURCE IS DISCONNECTED AND ALL MOVING PARTS ARE BLOCKED OUT TO PREVENT INJURY. WEAR PROTECTIVE CLOTHING.

- A. MAKE CERTAIN THAT ALL GUARDS AND COVERS ARE IN PLACE.
- B. CHECK FOR WORN, DAMAGED OR MISSING PARTS INCLUDING: BELTS, SAFETY GUARDS AND PROTECTIVE COVERS.
- C. MAKE SURE THAT ALL FASTENERS ARE TIGHTENED SECURELY.
- D. ON A DAILY BASIS, INSPECT THE UNIT AND CHECK TO BE CERTAIN THAT ALL SYSTEMS ARE OPERATING NORMALLY. DETAILED INSPECTION AND TESTING PROCEDURES ARE SPECIFIED FOR VARIOUS COMPONENTS AT REGULAR INTERVALS. SET UP A CHART AND ASSIGN RESPONSIBILITY FOR THESE ITEMS.



CAUTION: REPLACE ANY DAMAGED OR MISSING SAFETY LABELS. THEY ARE AVAILABLE FROM THE MANUFACTURER.

IMPORTANT:

MAINTENANCE FOR THE ROTARY KNIFE DIVIDER - 2201 ALWAYS BEGINS WITH KEEPING THE MACHINE CLEAN. PROPER CLEANING PROCEDURES CAN BE FOUND ON PAGE (8) OF THIS MANUAL. STANDARD LONG-TERM MAINTENANCE CONSISTS OF LUBRICATING MAIN WEAR POINTS OF THE WITH AN ALL-PURPOSE LITHIUM BASE GREASE. A GREASE GUN WITH A FLEXIBLE HOSE IS NEEDED.

NOTE:

ALL RECOMMENDATIONS FOR MAINTENANCE, BASED ON A 7 DAY, 8 HOUR PER DAY WORK SCHEDULE. HEAVIER WORK SCHEDULES WILL REQUIRE MORE FREQUENT MAINTENANCE.

MAINTENANCE PROCEDURES

 **DANGER:** ALWAYS DISCONNECT ELECTRICAL POWER SOURCE WHEN CLEANING, MAINTAINING OR REPAIRING THIS MACHINE...

THE FIRST STEP IS TO REMOVE THE TWO (2) CABINET COVERS (PART NO.'S RK148-088 & RK148-089). ONCE YOU HAVE COMPLETED THIS STEP YOU SHOULD BE ABLE TO VIEW ALL FOUR (4) CHAIN DRIVES OF THE MACHINE. TWO (2) CHAINS ON THE LEFT SIDE OF THE MACHINE, ONE (1) ON THE RIGHT SIDE AND ONE (1) FROM THE MAIN DRIVE MOTOR (PART NO. SS259).

LOCATE THE RIGHT SIDE OF THE MACHINE (FIGURE 1). THIS SIDE WILL HAVE THE SINGLE DRIVE CHAIN. YOU WILL NOTICE THE NINE (9) BEARING FLANGES, EIGHT (8) TWO (2) HOLE FLANGES AND ONE (1) FOUR (4) HOLE FLANGE. WITH A GREASE GUN, APPLY A SMALL AMOUNT OF GREASE TO THE FITTINGS. YOU WILL ALSO NOTICE A GREASE FITTING COMING OFF (PART NO. K203RS2A) NEAR THE MIDDLE OF THIS PANEL. THIS MAKES A TOTAL OF TEN (10) GREASE FITTINGS FOR THE RIGHT SIDE.

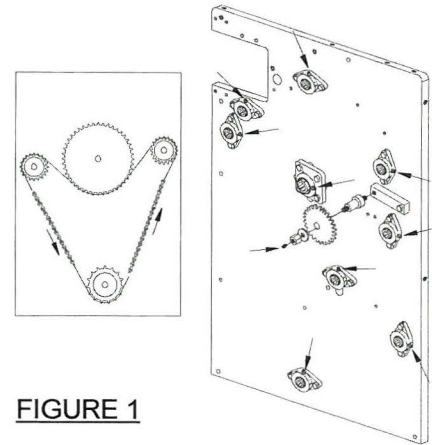

FIGURE 1

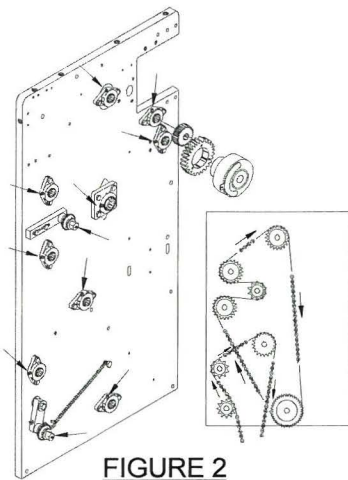
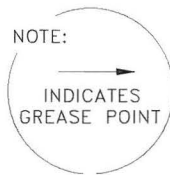

FIGURE 2



LOCATE THE LEFT SIDE OF THE MACHINE (FIGURE 2). THIS SIDE WILL HAVE TWO (2) DRIVE CHAINS. REPEAT THE ABOVE STEP FOR ALL FLANGE BEARINGS SINCE THEY ARE IDENTICAL TO THE RIGHT SIDE OF THE MACHINE. ONLY ON THIS SIDE THERE WILL BE TWO (2) MORE GREASE FITTINGS. ONE (1) COMING OFF (PART NO. K104LS1A) AND THE OTHER GREASE FITTING COMING OFF (PART NO. K203RS2A), THESE ARE BOTH TENSION SHAFTS.

ALL GREASE FITTINGS SHOULD BE GREASED ONCE A WEEK.

THE ROTARY KNIFE DIVIDER - 2201, HAS FOUR (4) DRIVE CHAINS (PART NO.'S K124LS/K125LS/K209LS/K332RA). THESE PARTS MUST BE OILED REGULARLY WITH A LIGHT WEIGHT MACHINE OIL TO PROLONG LIFE OF THE SPROCKETS AS WELL AS THE DRIVE CHAINS. THOROUGHLY LUBRICATE EACH DRIVE CHAIN. THE NORMAL OPERATION OF THE MACHINE WILL EVENLY DISTRIBUTE THE OIL OVER THE ENTIRE CHAIN AND SPROCKETS. THIS PROCEDURE MUST BE REPLACED ONCE A WEEK.

NOTE:
CHAIN CONDITION AND TENSION SHOULD BE CHECKED WHEN OILING PROCEDURE IS ACCOMPLISHED.

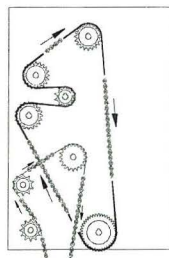

LEFT SIDE

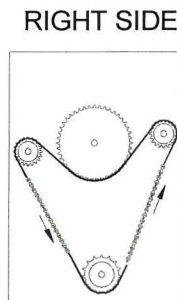

RIGHT SIDE



MAIN DRIVE MOTOR

MAIN DRIVE

MAINTENANCE PROCEDURES

BELT REPLACEMENT

 **WARNING:** CONVEYOR MAINTENANCE SHALL BE PERFORMED ONLY WHEN THE POWER SUPPLY HAS BEEN DISCONNECTED AND LOCKED OUT AND THE CONVEYOR HAS STOPPED.

DISCHARGE CONVEYOR BELT REPLACEMENT:

TO REPLACE THE DISCHARGE CONVEYOR BELT UNPLUG THE MACHINE FROM ITS PROPER RECEPTACLE TO ENSURE ALL POWER IS OFF.

- I. TO LOOSEN THE BELT FOR REMOVAL FIND (PART NO. 600SC) ROLLER SUPPORT BOLTS WITH (PART NO. F0601HN) ADJUSTING HEX NUT. TURN ADJUSTING HEX NUT COUNTER CLOCK-WISE. THIS IN TURN WILL BRING IN THE ROLLER AND LOOSEN THE BELT. THIS PROCEDURE MUST BE DONE TO BOTH SIDES OF THE BELT. (SEE FIGURE 2).

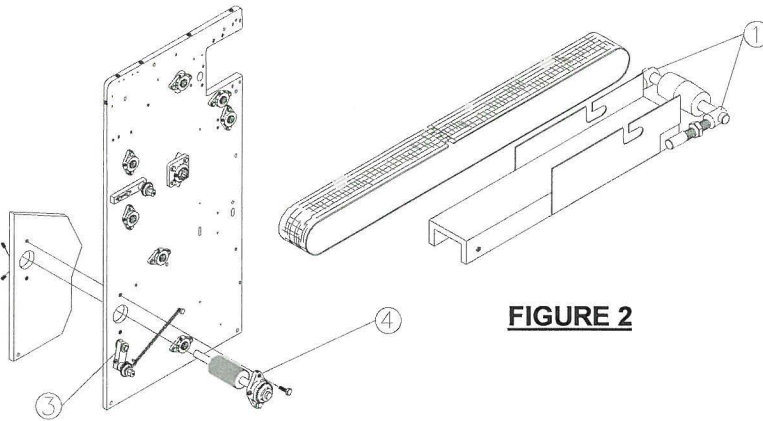

FIGURE 2

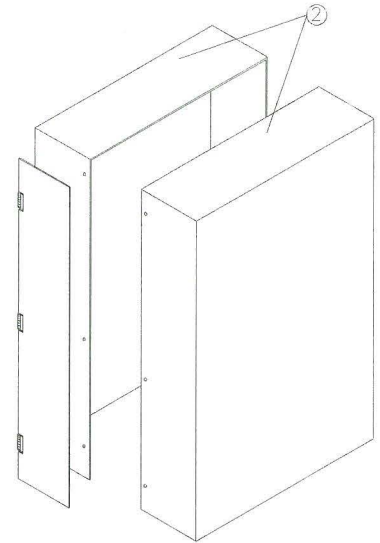

FIGURE 1

- II. REMOVE CABINET COVERS (PART NO.'S RK148-088 & RK148-089) FROM MACHINE TO EXPOSE INNER PANELS OF THE DIVIDER. (SEE FIGURE 1).
- III. LOCATE (PART NO. K203RS-1 TENSION BLOCK (ITEM #43) ON LEFT SIDE ASSEMBLY. RELEASE TENSION SPRING (PART NO. K120LS) (SEE FIGURE 2). THIS WILL ALLOW SLACK IN THE CHAIN (PART NO. K125LS) (ITEM #56) ON LEFT SIDE ASSEMBLY. NOW LOCATE MASTER-LINK IN CHAIN, REMOVE AND REMOVE CHAIN FROM AROUND SPROCKETS. (SEE FIGURE 3).
- IV. LOCATE THE FLANGE BEARING (PART NO. VF2S-212) (ITEM #2) ON LEFT SIDE ASSEMBLY THAT THE DISCHARGE CONVEYOR END SHAFT (PART NO. RK148-011 (ITEM #17) ON DISCHARGE CONVEYOR ASSEMBLY IS GOING THRU. REMOVE THE TWO (2) HEX HEAD BOLTS THAT HOLD THE FLANGE BEARING TO THE LEFT SIDE PANEL. (SEE FIGURE 2).

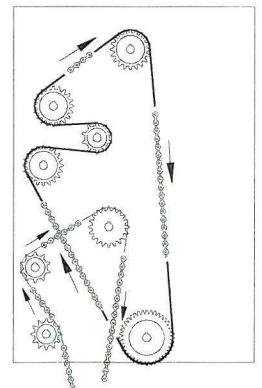



FIGURE 3

SWITCH TO THE RIGHT SIDE PANEL AND DIRECTLY ACROSS IS THE OTHER FLANGE BEARING THAT THE END SHAFT (PART NO. RK148-011) IS GOING THRU. (SEE FIGURE 2). LOOSEN THE TWO (2) SET SCREWS ON THE BEARING (NOT THE TWO (2) HEX BOLTS!). NOW TAKE A RUBBER Mallet AND GENTLY HIT THE END OF THE SHAFT TO PUSH IT THRU TO THE LEFT SIDE. REMOVE ENTIRE ROLLER ASSEMBLY AND PLACE IT NEXT TO MACHINE IN A CLEAN AREA.

MAINTENANCE PROCEDURES

BELT REPLACEMENT

 **WARNING:** CONVEYOR MAINTENANCE SHALL BE PERFORMED ONLY WHEN THE POWER SUPPLY HAS BEEN DISCONNECTED AND LOCKED OUT AND THE CONVEYOR HAS STOPPED.

INFEED CONVEYOR BELT REPLACEMENT

TO REPLACE THE IN-FEED CONVEYOR BELT UNPLUG THE MACHINE FROM IT'S PROPER RECEPTACLE TO ENSURE ALL POWER IS OFF.

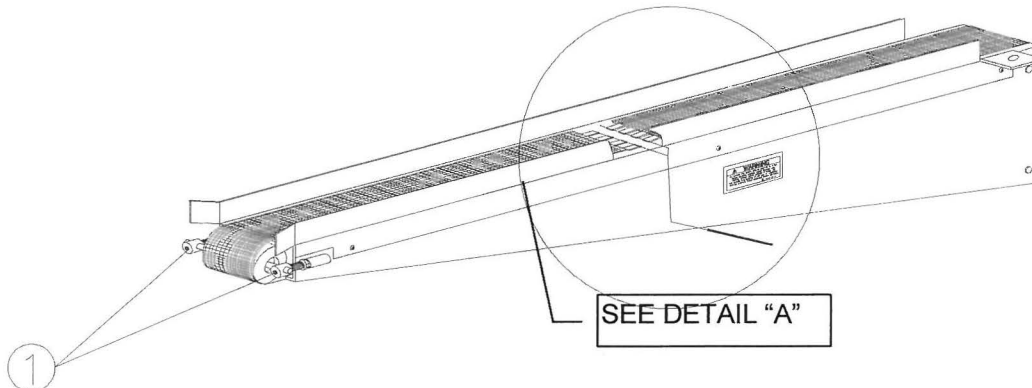

- I. TO LOOSEN THE BELT FOR REMOVAL FIND (PART NO. 600SC) ROLLER SUPPORT BOLTS WITH (PART NO. F0601HN) ADJUSTING HEX NUT. TURN ADJUSTING HEX NUT COUNTER CLOCK-WISE. THIS IN-TURN WILL BRING IN THE ROLLER AND LOOSEN THE BELT. THIS PROCEDURE MUST BE DONE TO BOTH SIDES OF THE BELT.
- II. TO REMOVE THE BELT FROM THE CONVEYOR, FIRST LOCATE THE ALLIGATOR LACING OR HINGE. YOU WILL SEE A PIN GOING THRU THE LACING. WITH PLIERS PULL THE PIN OUT. THE BELT WILL THEN COME APART, REMOVE BELT FROM MACHINE.
- III. TO REPLACE CONVEYOR BELT, FEED THE NEW BELT DOWN THE CONVEYOR AND AROUND BOTH ROLLERS. FIND THE ALLIGATOR LACING OR HINGE, INTERTWINE THE LACING AND SLIDE PIN THROUGH. TO TIGHTEN THE BELT, TURN THE ADJUSTING HEX NUTS (PART NO. F0601HN) CLOCK-WISE TO RE-TIGHTEN THE BELT.

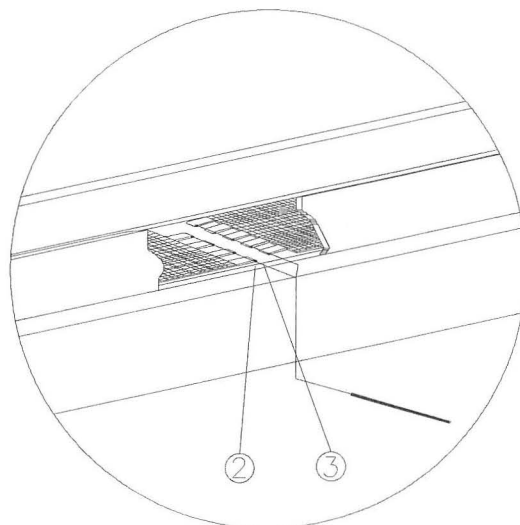

DETAIL "A"

PARTS CATALOG

	<u>PAGE</u>
PARTS CATALOG	13
INFEED CONVEYOR ASSEMBLY.....	14
DISCHARGE CONVEYOR ASSEMBLY.....	15
CABINET ASSEMBLY.....	16-17
ROLLER ASSEMBLY.....	18-19
LEFT SIDE ASSEMBLY.....	20-21
RIGHT SIDE ASSEMBLY.....	22-23
ELECTRICAL SYSTEM.....	24-25
ELECTRICAL (SCHEMATIC 208 / 230 VOLTS (2001)).....	26
ELECTRICAL (HARDWIRE 208 / 230 VOLTS (2001)).....	27
ELECTRICAL (SCHEMATIC 208 / 230 VOLTS (2201)).....	28
ELECTRICAL (HARDWIRE 208 / 230 VOLTS (2201)).....	29
ELECTRICAL (HARDWARE (RECTIFIER BLOCK (22021)).....	30
ORDERING REPLACEMENT PARTS.....	31
NOTES.....	32

IMPORTANT:

A.M. MANUFACTURING Co. RESERVES THE RIGHT TO MAKE CHANGES IN DESIGN, SPECIFICATIONS OR MANUFACTURING. TO IMPROVE THEIR PRODUCTS WITHOUT NOTICE AND WITHOUT OBLIGATION TO CHANGE OR IMPROVE PREVIOUSLY BUILT PRODUCTS INCLUDING MANUALS AND CATALOGS.

ONLY USE FACTORY SUPPLIED REPLACEMENT PARTS TO MAINTAIN MACHINE SAFETY, PERFORMANCE AND SANITARY CONDITIONS. USE OF NON-APPROVED PARTS MAY VOID MANUFACTURERS WARRANTY.

KNOW YOUR UNIT. COMPARE DIAGRAMS IN THIS MANUAL WITH THE UNIT BEFORE STARTING SERVICE, TO OBTAIN MAXIMUM SAFETY AND PERFORMANCE.

TO ORDER REPLACEMENT PARTS:
TURN TO PAGE 31 OF THIS MANUAL.



WARNING:

THIS MANUAL CONTAINS CRITICAL SAFETY INSTRUCTIONS. READ AND FOLLOW THEM CAREFULLY. FAILURE TO FOLLOW WARNING AND INSTRUCTIONS MAY LEAD TO SERIOUS PERSONAL INJURY. THE OWNER IS RESPONSIBLE FOR MAINTAINING THE UNIT, ITS INSTRUCTIONS AND DECALS FOR OPERATION REFERENCE. FOR ADDITIONAL COPIES CONTACT A.M. MANUFACTURING: (800)342-6744

INFEED CONVEYOR ASSEMBLY



IMPORTANT

KNOW YOUR UNIT. COMPARE DIAGRAMS IN THIS MANUAL WITH THE UNIT BEFORE STARTING SERVICE TO OBTAIN MAXIMUM SAFETY AND PERFORMANCE.

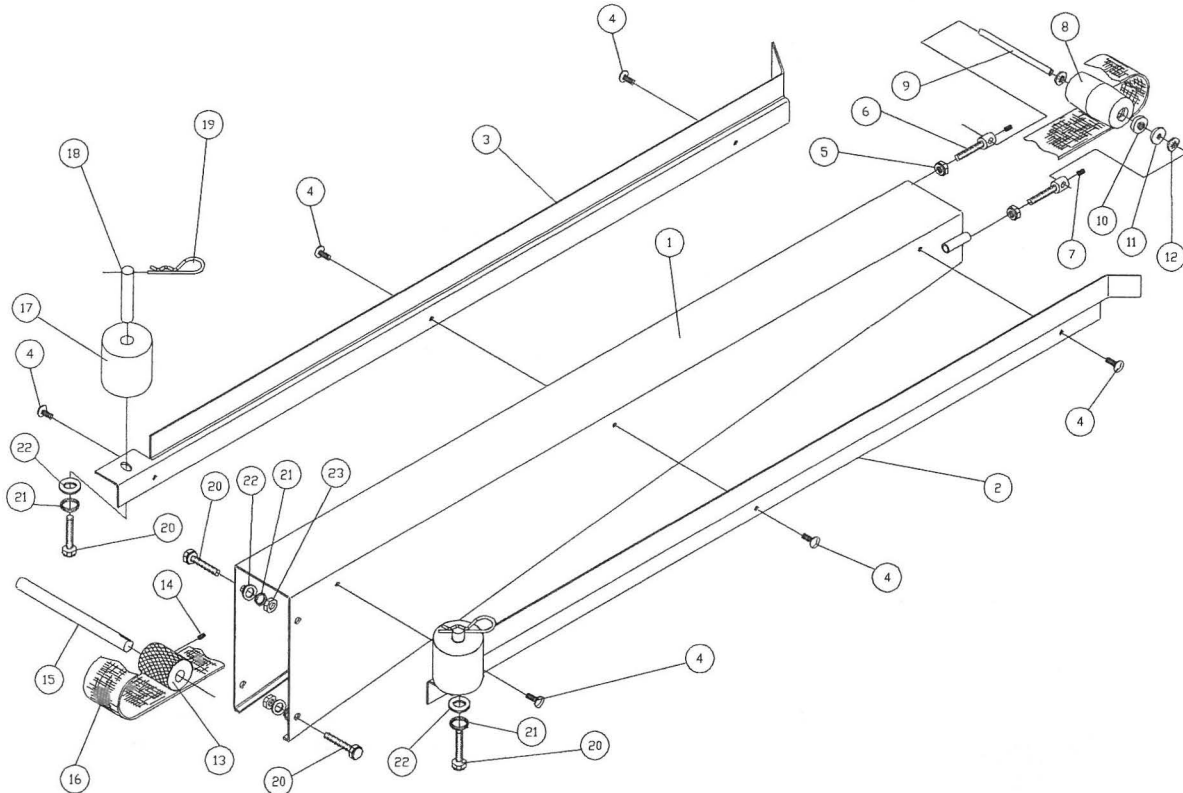

ITEM	PART NO.	DESCRIPTION	NO. REQ'D
1	RK148-038	INFEED CONVEYOR	1
2	K420CA3	LEFT-SIDE INFEED RAIL	1
3	K420CA2	RIGHT-SIDE INFEED RAIL	1
4	F0402RH	ROUND HEAD SCREW	6
5	F0600LN	LOCK NUT	2
6	600SC	ROLLER SUPPORT BOLT	2
7	F0401SS	SET SCREW	2
8	RK148-004	INFEED CONVEYOR ROLLER	1
9	RK148-003	ROLLER CENTER SHAFT	1
10	641SC2	BEARING	2
11	F0600NW	NYLON WASHER	2
12	F0600RW	RETAINING WASHER	2
13	RK148-006	INFEED CONVEYOR DRIVE ROLLER	1
14	F0502SS	SET SCREW	1
15	RK148-011	INFEED CONVEYOR SHAFT	1
16	K415CAIFC-2	STD. INFEED CONVEYOR BELT	1
17	RK148-081	INFEED IDLER ROLLER	2
18	RK148-082	ROLLER SHAFT	2
19	F0210HCP	HAIRPIN COTTER PIN	2
20	F0505HH	BOLT	6
21	F0500LW	LOCK WASHER	6
22	F0500FW	FLAT WASHER	6
23	F0500JN	NUT	4

DISCHARGE CONVEYOR ASSEMBLY

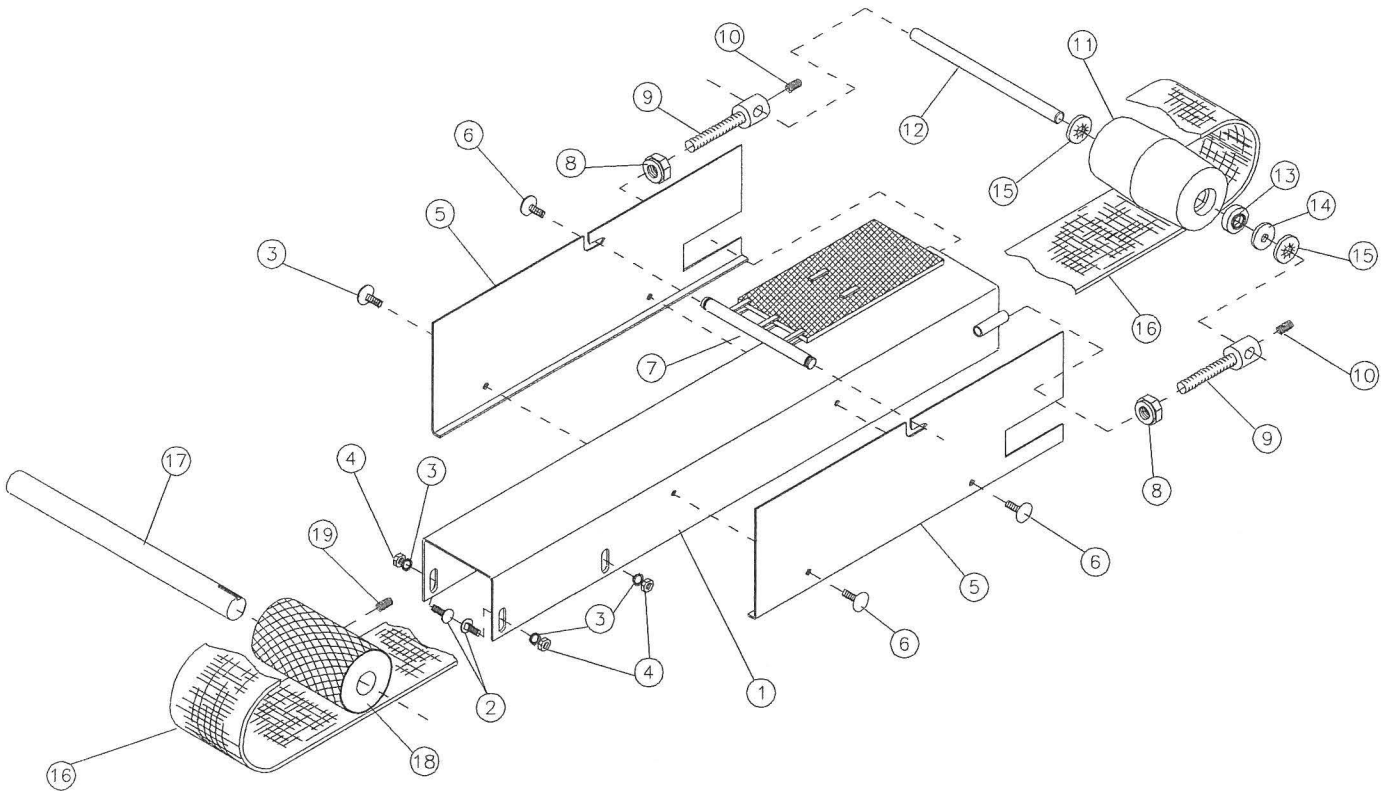

ITEM	PART NO.	DESCRIPTION	NO. REQ'D
1	RK148-037	DISCHARGE CONVEYOR FRAME	1
2	F0402CB	CARRIAGE BOLT	4
3	F0400LW	LOCK WASHER	4
4	F0400JN	JAM NUT	4
5	RK148-053	DISCHARGE CONVEYOR RIGHT & LEFT SIDE PLATE	2
6	F0402RH	BOLT	4
7	RK148-077	WIRE BELT ASSEMBLY	1
8	F0600LN	LOCK NUT	2
9	600SC	ROLLER SUPPORT BOLT	2
10	F0401SS	SET SCREW	2
11	RK148-004	DISCHARGE CONVEYOR IDLE ROLLER	1
12	RK148-003	ROLLER SHAFT	1
13	641SC2	BEARING	2
14	F0600FW	FLAT WASHER (NYLON)	2
15	F0600RW	RETAINING WASHER	2
16	K414CADC2	STD. DISCHARGE CONVEYOR BELT	1
17	RK148-011	DISCHARGE CONVEYOR DRIVE SHAFT	1
18	RK148-005	DISCHARGE CONVEYOR DRIVE ROLLER	1
19	F0502SS	SET SCREW	1

CABINET ASSEMBLY

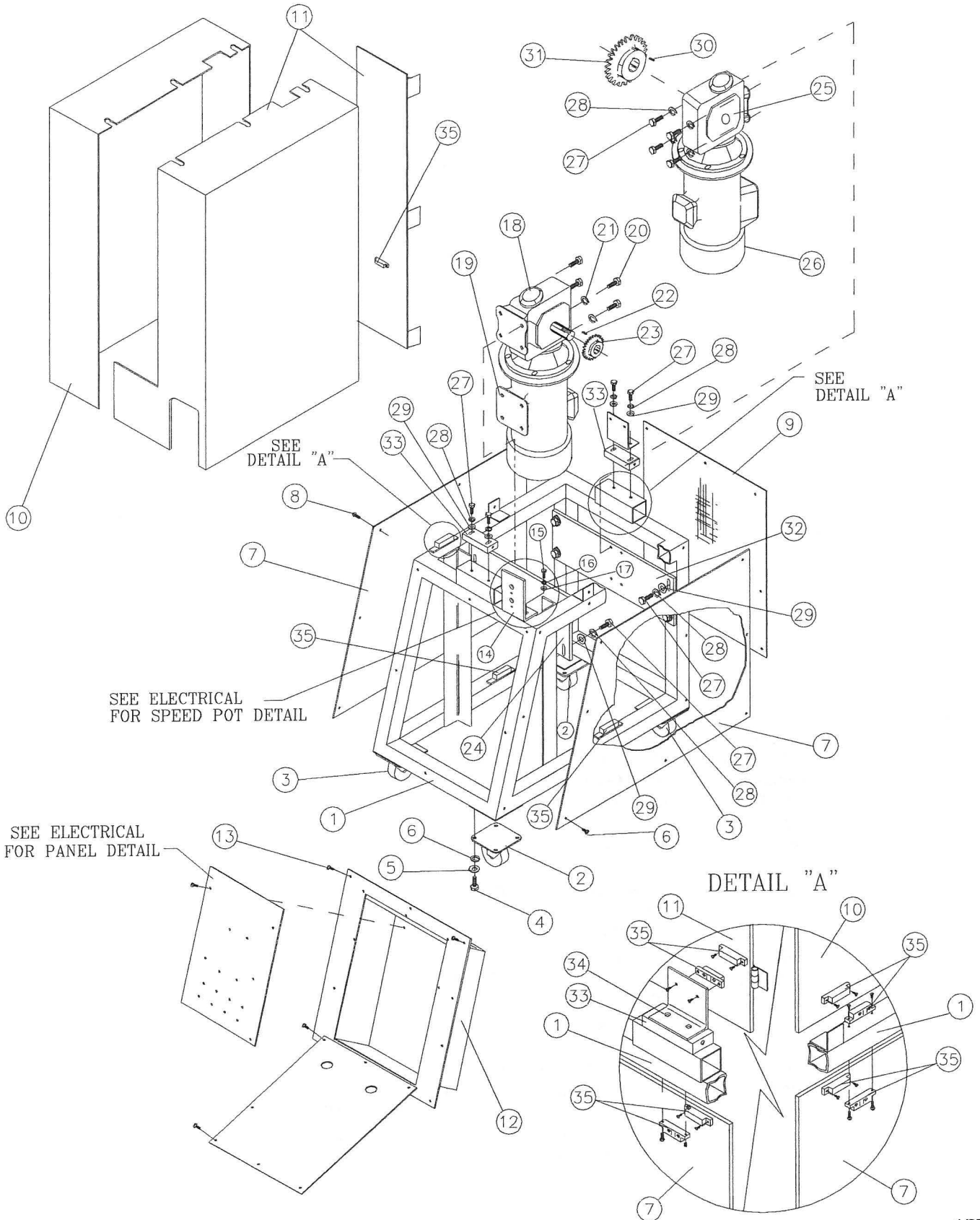

CABINET ASSEMBLY

ITEM	PART NO.	DESCRIPTION	NO. REQ'D
1	K602C	CABINET FRAME	1
2	621CA1	CASTER ROLLER	2
3	621CA2	LOCKING CASTER ROLLER	2
4	F0402HH	BOLT	16
5	F0400FW	FLAT WASHER	16
6	F0400LW	LOCK WASHER	16
7	K605C	CABINET FRAME SIDE PANEL	2
8	F0402BHS	BUTTON HEAD SOCKET CAP SCREW	16
9	K608C	CABINET FRAME BACK PANEL	1
10	RK148-088	CABINET CASE (LEFT SIDE)	1
11	RK148-089	CABINET CASE (RIGHT SIDE)	1
12	K603C	ELECTRIC BOX	1
13	F0403RD	ROUND HEAD	9
14	DK825CA-6	SPEED CONTROL BRACKET	1
15	F0303HH	BOLT	2
16	F0300LW	LOCK WASHER	2
17	F0300FW	FLAT WASHER	2
18	SS258	REDUCER	1
19	SS259	ELECTRIC MAIN DRIVE MOTOR	1
20	F0604HH	BOLT	4
21	F0600LW	LOCK WASHER	4
22	F0403KY	SHAFT KEY	1
23	K620C	REDUCER SPROCKET	1
24	K607C	MAIN DRIVE MOTOR MOUNT PLATE	1
25	SS410	REDUCER	1
26	SS257	ELECTRIC KNIFE/DISCHARGE MOTOR	1
27	F0505HH	BOLT	16
28	F0500LW	LOCK WASHER	16
29	F0500FL	FLAT WASHER	12
30	F0303KY	SHAFT KEY	1
31	K617C	MAIN DRIVE MOTOR SPOCKET	1
32	K606C	KNIFE/DISCHARGE MOTOR DRIVE PLATE	1
33	RK148-018	SPACER BLOCK	2
34	RK148-066	MAGNETIC REED SWITCH ANGLE BRACKET	1
35	SS240	MAGNETIC REED SWITCH	6

NOTE:

GUARDS ARE INTERLOCKED, MACHINE
 WILL NOT OPERATE WITHOUT GUARDS IN
 PLACE.

ROLLER ASSEMBLY

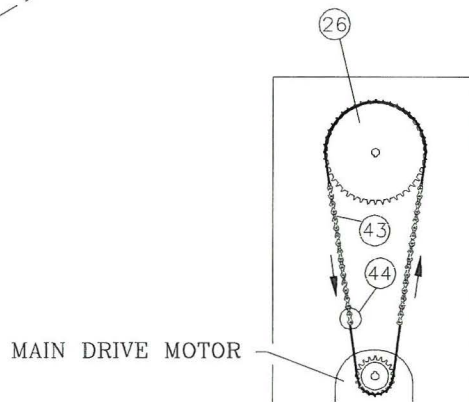
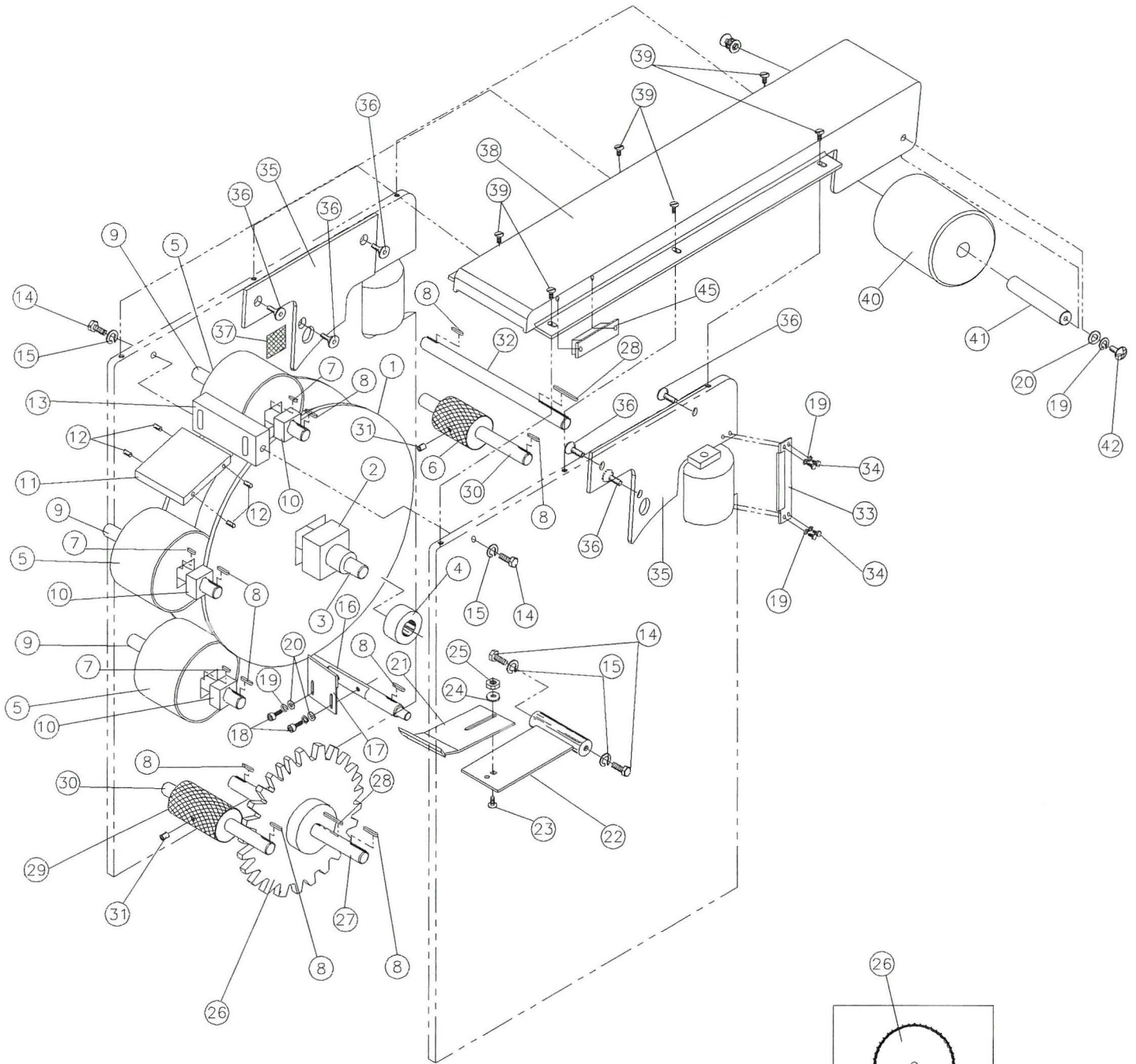

MAIN DRIVE MOTOR

ROLLER ASSEMBLY

ITEM	PART NO.	DESCRIPTION	NO. REQ'D
1	RK148-042	DRUM ROLLER	1
2	RK148-063	DRIVER PLUG	1
3	RK148-039	DRUM SHAFT	1
4	K331RA	DRUM SPACER	2
5	RK148-032	SIZING ROLLER	3
6	RK148-005	INFEED CONVEYOR DRIVE ROLLER	1
7	K333RA	SHAFT KEY	3
8	K332RA	SHAFT KEY	9
9	RK148-008	SIZING ROLLER SHAFT	3
10	K315RA	DRIVER PLUG	3
11	RK148-002	SIZING ROLLER GUARD	1
12	F0402SS	SET SCREW	4
13	RK148-018	SPACER BLOCK	1
14	F0504HH	HEX HEAD BOLT	4
15	F0500LW	LOCK WASHER	4
16	RK148-010	KNIFE SHAFT	1
17	RK148-013	KNIFE	1
18	F0402SH	SOCKET HEAD	2
19	F0400LW	LOCK WASHER	8
20	F0400FW	FLAT WASHER	4
21	RK148-083	DRUM SCRAPPER	1
22	RK148-014	DRUM SCRAPPER BASE	1
23	F0503CB	CARRIAGE BOLT	1
24	F0500FT	FLAT HEAD	1
25	F0500JN	JAM NUT	1
26	K327RA	SPROCKET	1
27	RK148-009	COUNTER SHAFT	1
28	K334RA	SHAFT KEY	2
29	RK148-006	DISCHARGE CONVEYOR DRIVE ROLLER	1
30	RK148-011	CONVEYOR SHAFT	2
31	F0501SS	SET SCREW	2
32	RK148-015	CLUTCH SHAFT	1
33	RK148-049	ROLLER SCRAPPER	2
34	F0402HH	HEX HEAD BOLT	8
35	RK148-061	DRUM GUIDE (RIGHT & LEFT)	2
36	F0402FHS	FLAT HEAD SOCKET CAP SCREW	6
37	807	REFLECTIVE TAPE	1
38	RK148-048	TOP COVER GUARD	1
39	F0402BHS	BUTTON HEAD SOCKET CAP SCREW	6
40	RK148-052	GUARD ROLLER	1
41	RK148-051	GUARD ROLLER SUPPORT SHAFT	1
42	F0403TH	TRUSS HEAD ONE-WAY SCREW	2
43	K337RA	#40 CHAIN	1
44	K118LS	#40 MASTER LINK	1
45	SS240	MAGNETIC REED SWITCH	1

LEFT SIDE ASSEMBLY

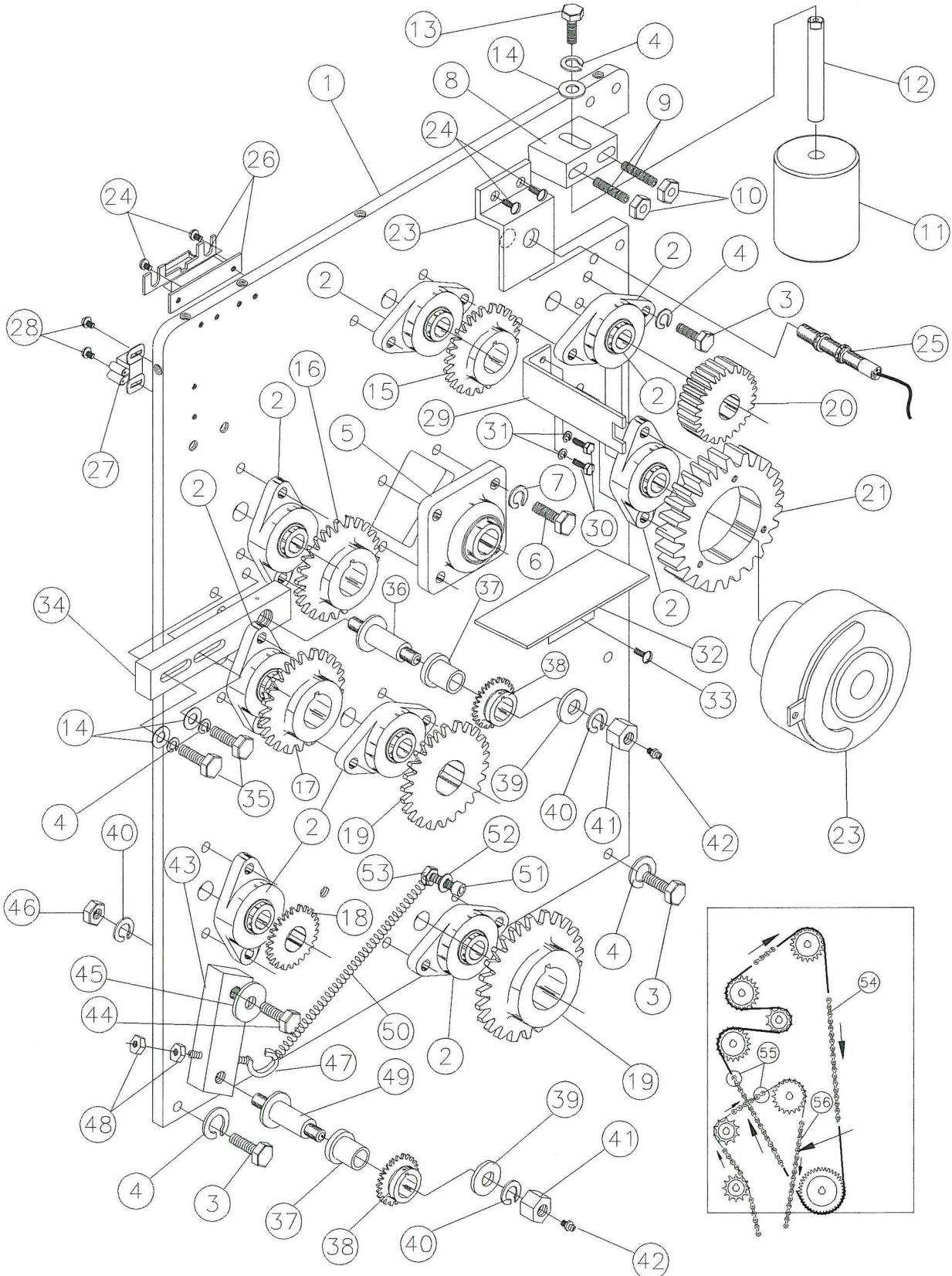

LEFT SIDE ASSEMBLY

ITEM	PART NO.	DESCRIPTION	NO. REQ'D
1	RK148-027	LEFT SIDE PANEL	1
2	VF2S-212	BEARING FLANGE (2) HOLE	8
3	F0504HH	HEX HEAD BOLT	19
4	F0500LW	LOCK WASHER	19
5	VF4S-216	BEARING FLANGE (4) HOLE	1
6	F0605HH	HEX HEAD BOLT	4
7	F0600LW	LOCK WASHER	4
8	RK148-045	ROLLER SUPPORT BLOCK	1
9	F0508SS	SET SCREW	2
10	F0500NJN	NYLON JAM NUT	2
11	RK148-047	DOUGH GUIDE ROLLER	1
12	RK148-046	DOUGH GUIDE ROLLER SHAFT	1
13	F0505HH	HEX HEAD BOLT	1
14	F0500FW	FLAT WASHER	3
15	K112LS	SIZING ROLLER SPROCKET	1
16	K117LS	SIZING ROLLER SPROCKET	1
17	K111LS	SIZING ROLLER SPROCKET	1
18	K115LS	DISCHARGE SPROCKET	1
19	K116LS	COUNTER / KNIFE SPROCKETS	2
20	K109LS	INFEEED CONVEYOR DRIVE GEAR	1
21	K108LS	GEAR (DRIVER CLUTCH)	1
22	SS238	CLUTCH	1
23	RK148-070	PHOTO EYE BRACKET	1
24	F9702TH	TRUSS HEAD	4
25	SS363-1	PHOTO EYE	1
26	SS240	MAGNETIC REED SWITCH	1
27	K122LS	DOOR HINGE CLAMP	1
28	F9706PH	PAN HEAD SCREW	2
29	K102LS	ANTI-ROTATION BRACKET	1
30	F0402HH	HEX HEAD BOLT	2
31	F0400LW	LOCK WASHER	2
32	K533ES	RECTIFIER GUARD	1
33	F9912TH	TRUSS HEAD	1
34	K104LS-1	TENSION PLATE	1
35	F0506HH	HEX HEAD BOLT	2
36	K104LS1A	SPROCKET TENSION MOUNT SHAFT	1
37	BBT15	BRONZE BUSHING	2
38	K113LS	TENSION SPROCKET	2
39	F0800FL	FLAT WASHER	3
40	F0800LW	LOCK WASHER	3
41	F0800NC	HEX NUT	2
42	3038-B	GREASE FITTING	2
43	K203RS-1	TENSION BAR	1
44	H0808HH	BOLT	1
45	F0800FW	FLAT WASHER	3
46	F0800JN	JAM NUT	1
47	F0508EB	EYE BOLT	1
48	F0500NC	HEX NUT	2
49	K203RS2A	SPROCKET TENSION MOUNT SHAFT	1
50	K120LS	TENSION SPRING	1
51	F0404SH	SOCKET HEAD CAP SCREW	1
52	F0400FL	FLAT WASHER	1
53	F0400JN	JAM NUT	1
54	K124LS	NO. 40 CHAIN (DRIVES SIZING ROLLERS)	1
55	K118LS	NO. 40 CHAIN MASTER LINK	2
56	K125LS	NO. 40 CHAIN (DRIVES DISCHARGE & KNIFE)	1

RIGHT SIDE ASSEMBLY

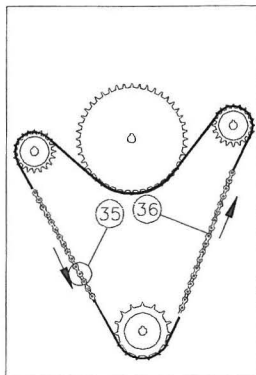
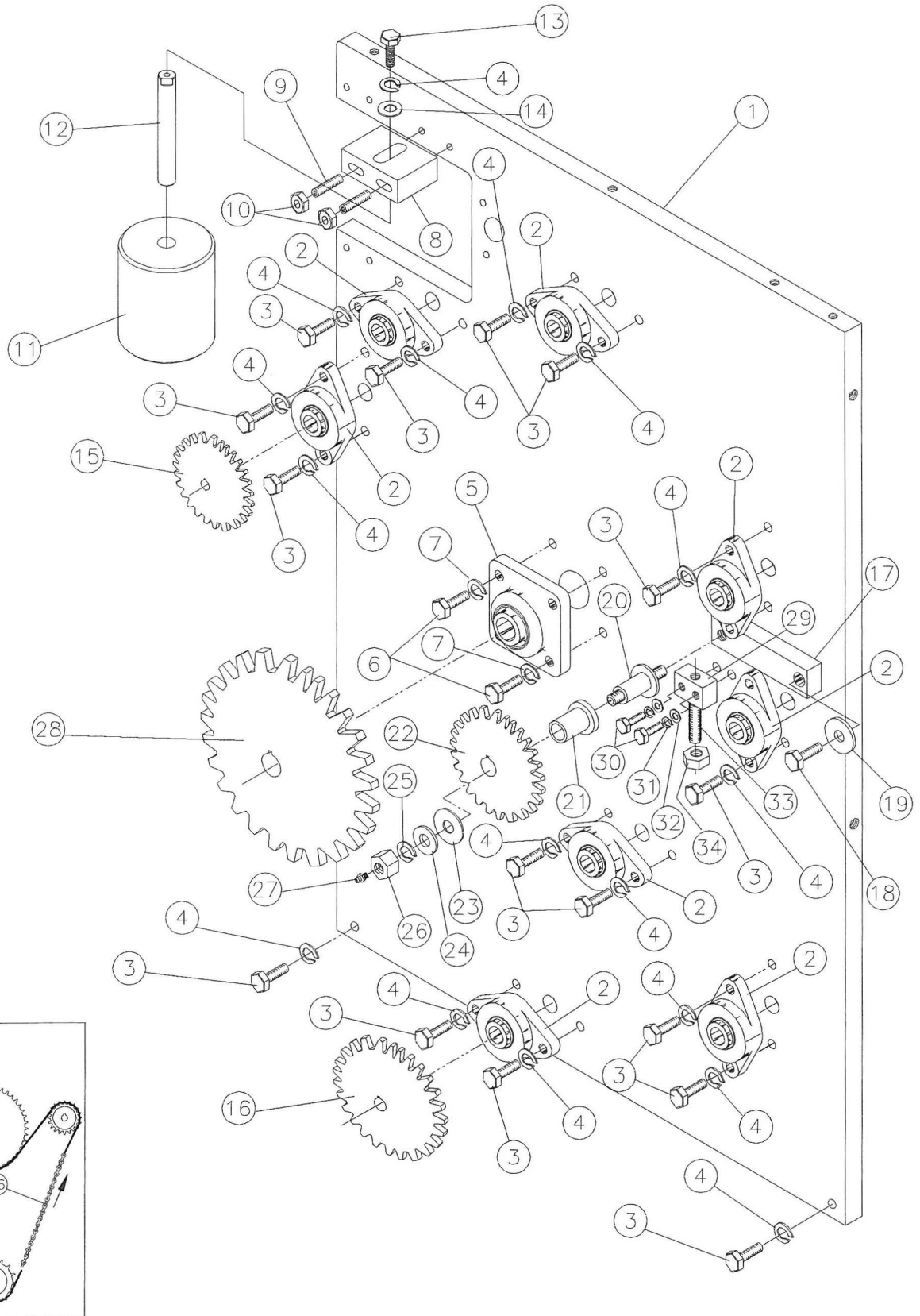

RIGHT SIDE ASSEMBLY

ITEM	PART NO.	DESCRIPTION	NO. REQ'D
1	RK148-028	RIGHT SIDE PANEL	1
2	VF2S-212	(2) HOLE BEARING FLANGE	8
3	F0504HH	HEX HEAD BOLT	19
4	F0500LW	LOCK WASHER	19
5	VF4S-216	(4) HOLE BEARING FLANGE	1
6	F0605HH	HEX HEAD BOLT	4
7	F0600LW	LOCK WASHER	4
8	RK148-045	ROLLER SUPPORT BLOCK	1
9	F0508SS	SET SCREW	2
10	F0500NJN	NYLON JAM NUT	2
11	RK148-047	DOUGH GUIDE ROLLER	1
12	RK148-046	DOUGH GUIDE ROLLER SHAFT	1
13	F0505HH	HEX HEAD BOLT	1
14	F0500FL	FLAT WASHER	1
15	K206RS	INFEED CONVEYOR SPROCKET	1
16	K207RS	COUNTER SPROCKET	1
17	K203RS-1	TENSION BAR	1
18	F0806HH	HEX HEAD BOLT	1
19	F0800FL	FLAT WASHER	1
20	K203RS2A	SPROCKET TENSION MOUNT SHAFT	1
21	BBT15	BRONZE BUSHING	1
22	K213RS	TENSION SHAFT SPROCKET	1
23	BBT18	NYLON WASHER	1
24	F0800FW	FLAT WASHER	2
25	F0800LW	LOCK WASHER	1
26	F0800NC	HEX NUT	1
27	3038-B	GREASE FITTING	1
28	K208RS	DRUM ROLLER SPROCKET	1
29	K204RS	TENSION ADJUSTMENT BLOCK	1
30	F0406HH	HEX HEAD BOLT	2
31	F0400LW	LOCK WASHER	2
32	F0400FW	FLAT WASHER	2
33	K211RS	SET SCREW	1
34	F0500JN	JAM NUT	1
35	K212RS	NO. 50 CHAIN MASTER LINK	1
36	K209RS	NO. 50 CHAIN	1

ELECTRICAL SYSTEM

ITEM	PART NO.	DESCRIPTION	NO. REQ'D
1	K603C	ELECTRICAL BOX	1
2	K613C	ELECTRICAL SUB-PANEL	1
3	SS219	14/4 CAROLPRENE	15 FT.
4	SS277	90deg. ELBOW	3
5	SS159	PLUG	1
6	400040	GROMMET	2
7	SS178	TRANSFORMER	1
8	SS294	OVERLOAD RELAY W/ 1-SS297 & 1-SS382 OVERLOADS	2
** 9	SS193	MOTOR CONTROLLER	2
10	SS236	CONTROL RELAY	1
11	SS142	FUSE BLOCK	3
12	SS135	FUSE (5 AMP.)	4
13	SS136	FUSE (8 AMP)	2
14	K509ES	"U" BRACKET	2
15	SS144	TERMINAL BLOCK	22
16	SS145	TERMINAL BLOCK END	2
17	F9704TH	#8-32 SLOTTED TRUSS HEAD BOLT	24
* 18	SS231	20A-250V3 DIA. RECEPTACLE	1
* 19	SS230	20A-125/250V RECEPTACLE	1
* 20	SS235	ALUM. WALL PLATE W/ LIFT COVER	2
21	F9902TH	SCREW	4
22	400091	10 TURN	2
23	DK825CA6	SPEED CONTROL BRACKET	1
24	400092	SPEED POT	2
25	K533ES	BRIDGE RECTIFIER BLOCK GUARD	1
26	K532ES	BRIDGE RECTIFIER BLOCK	1
27	SS229	BRIDGE RECTIFIER	1
28	SS363-1	PHOTO EYE	1
29	SS258	REDUCER MOTOR	1
30	SS259	MAIN DRIVE MOTOR	1
~ 31	SS410	REDUCER MOTOR	1
~ 32	SS257	ELECTRIC KNIFE/DISCHARGE MOTOR	1
33	SS238	CLUTCH	1
34	SS240	MAGNETIC REED SWITCH	5

- ** MOTOR VOLTAGE MUST BE REQUESTED WHEN ORDERING THIS ITEM.
- * OPTIONAL WITH ROTARY KNIFE DIVIDER/FORMER: MODEL RK2100.
- ~ PARTS MAY CHANGE FROM THE DATE THEY WERE GIVEN (11-17-97).

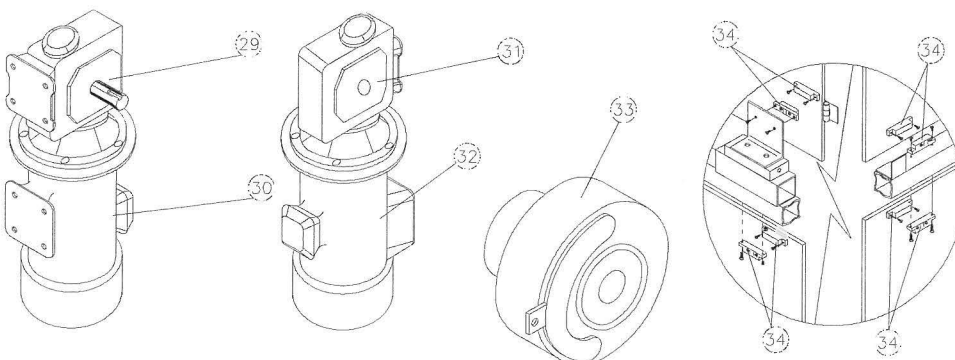

ELECTRICAL (SCHEMATIC) RK2001

SINGLE PHASE 230 / 208 VOLTS

CONVEYOR PLUG
 2321

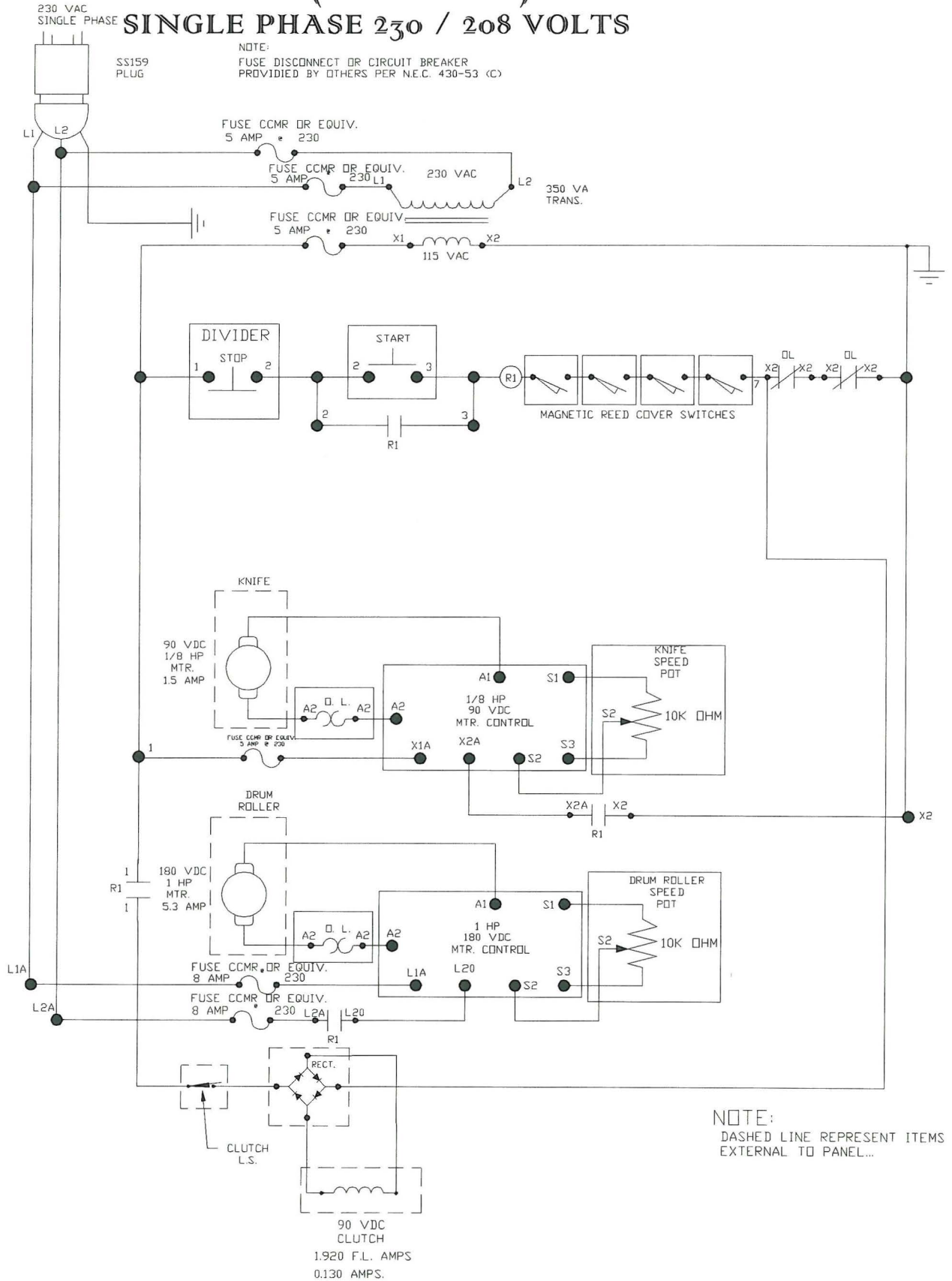

ELECTRICAL (HARDWIRE) RK2001 SINGLE PHASE 230/208 VOLTS

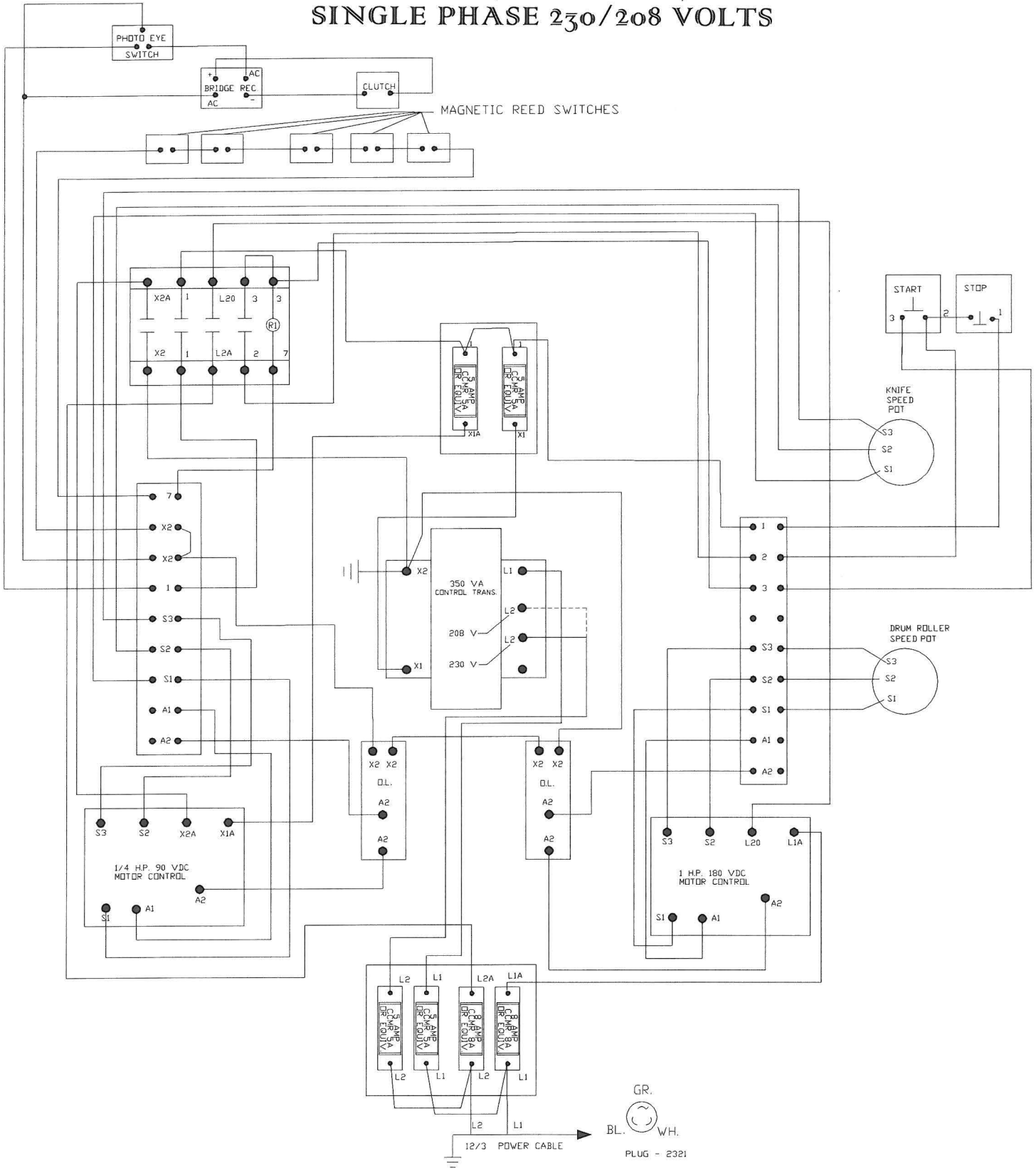

ELECTRICAL (SCHEMATIC) RK2201

THREE PHASE 230 / 208 VOLTS

NOTE:
 FUSE DISCONNECT OR CIRCUIT BREAKER
 PROVIDED BY OTHERS PER N.E.C. 430-53 (C)

PLUG
 GLD 1521

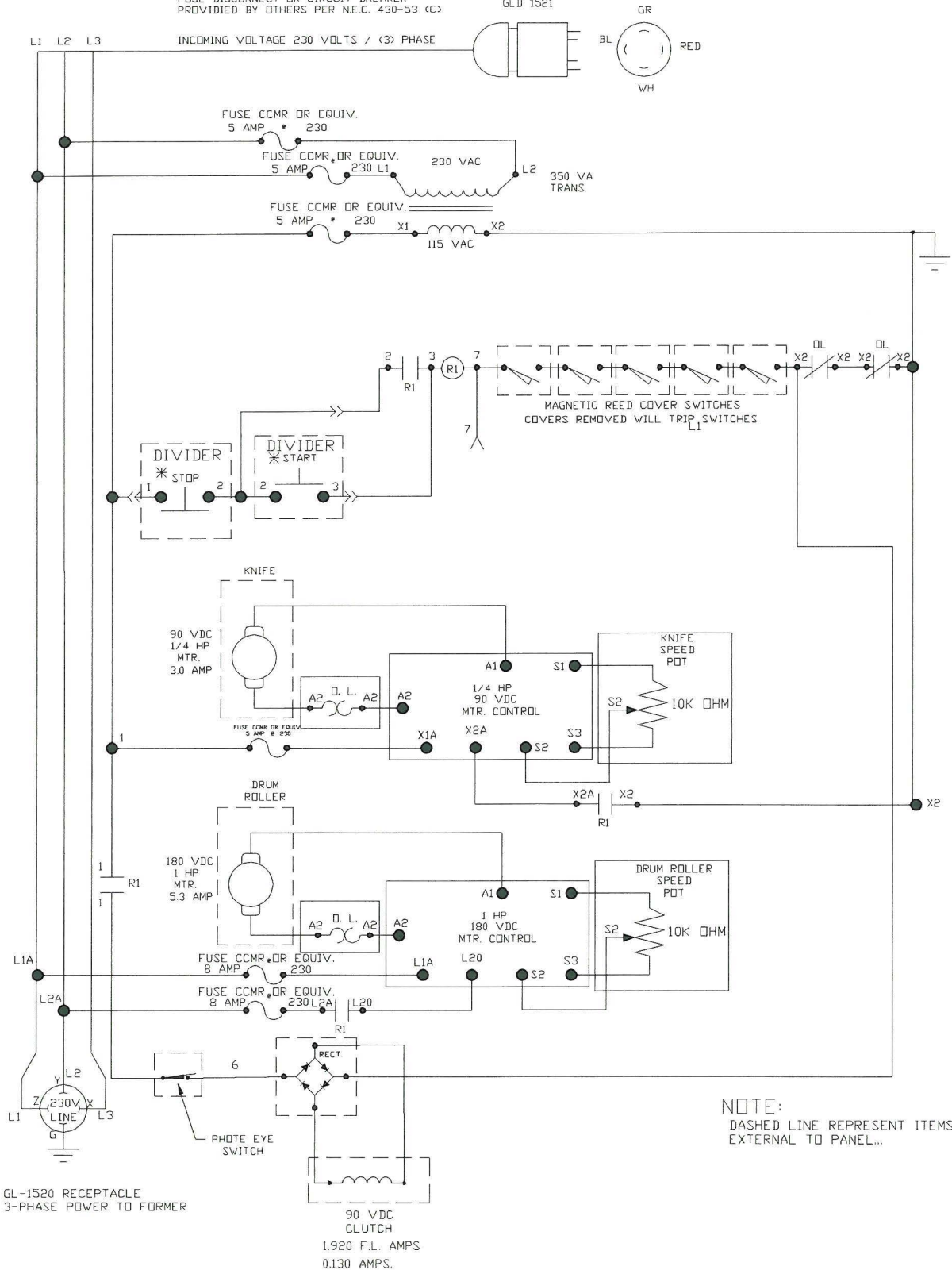

ELECTRICAL (HARDWIRE) RK2201 THREE PHASE 230/208 VOLTS

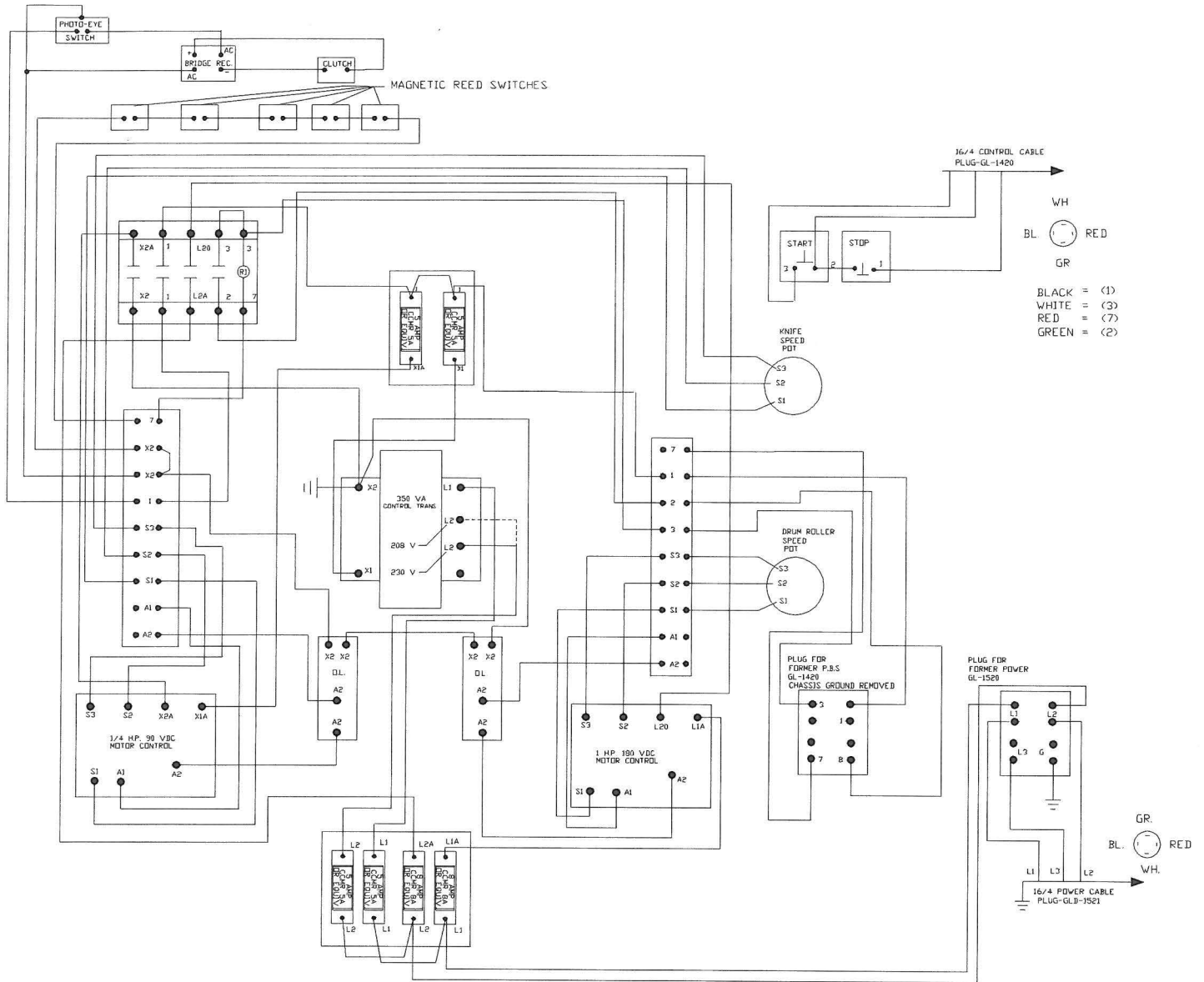

ELECTRICAL (HARDWIRE) RK2201 BRIDGE RECTIFIER BLOCK

PHOTOEYE WIRE DIAGRAM

<u>WIRE COLOR</u>	<u>CONTACT BLOCK #</u>
BLUE	X2
BROWN	1
BLACK	6

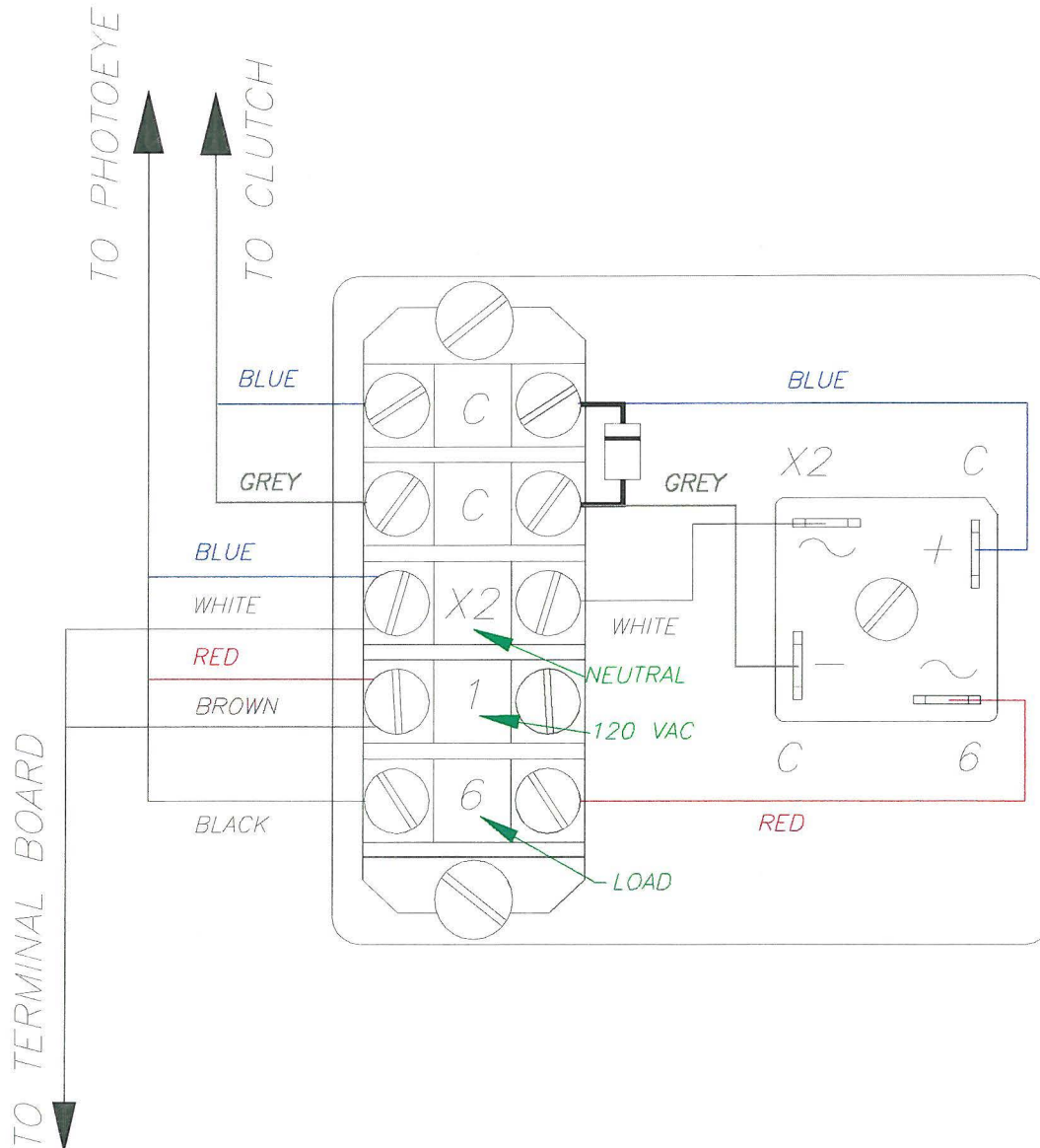

ORDERING REPLACEMENT PARTS

IMPORTANT:

ONLY USE FACTORY SUPPLIED REPLACEMENT PARTS TO MAINTAIN MACHINE SAFETY, PERFORMANCE AND SANITARY CONDITIONS.

USE OF NON-APPROVED PARTS MAY VOID MANUFACTURES WARRANTY.

TO ORDER REPLACEMENT PARTS ALWAYS:

- 1) CHECK THE MACHINE TOP IDENTIFY MISSING, DAMAGED OR NON-FUNCTIONAL PARTS INCLUDING GUARDS, WARNING LABELS AND INSTRUCTIONS.
- 2) COMPARE THE LIST WITH THE PARTS DIAGRAMS SUPPLIED.
- 3) RECORD THE COMPLETE MODEL AND SERIAL NUMBER OF THE UNIT.
- 4) CALL A.M. MANUFACTURING (800) 342-6744 AND PROVIDE ALL INFORMATION NOTED ABOVE TO EXPEDITE ORDER PROCESSING AND HELP REDUCE SHIPPING COST.
- 5) PROVIDE COMPLETE DETAILS FOR (SHIP TO) AND (BILL TO) INFORMATION. TO ASSIST PROMPT DELIVERY, SPECIFY TYPE OF CARRIER PREFERRED IN SHIPMENT.
- 6) MOST MAJOR CREDIT CARDS ACCEPTED.

MAINTENANCE PROCEDURES (FOR JOINING MACHINES) PART # RK22CONN



CAUTION: FOR SAFE ASSEMBLY, AT LEAST (3) TWO PEOPLE ARE REQUIRED. THE MACHINES ARE HEAVY AND MAY CAUSE STRAIN TO AN INDIVIDUAL.

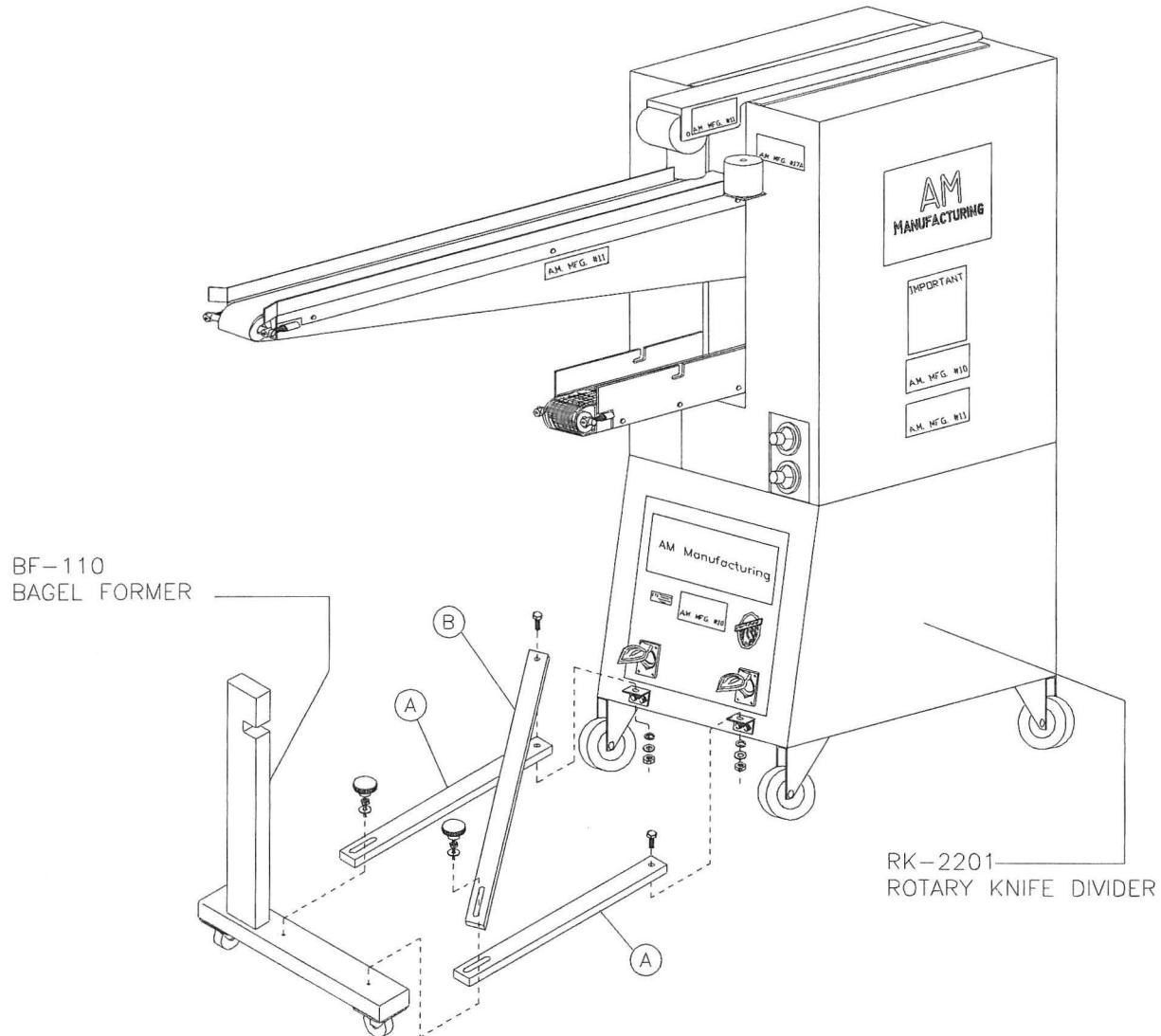

- 1) THE SHORTER BARS "A" (PART # K622C) ARE ATTACHED FROM THE DIVIDER TO THE FORMER SO THAT THEY ARE PARALLEL TO EACH OTHER.
- 2) THE SINGLE LONG BAR "B" (PART # K623C) RUNS AT A DIAGONAL FROM THE RIGHT SIDE OFF THE DIVIDER (LOOKING TOWARDS THE FORMER) TO THE LEFT SIDE OF THE FORMER LEG AND IS MOUNTED ON TOP OF THE PARALLEL BARS "A".
- 3) THE SLOTS IN BOTH "A" & "B" ARE POSITIONED AT THE FORMER END.
- 4) THE 3/8" BOLTS ARE USED TO ATTACH THE BARS TO THE DIVIDER ATTACHMENT LUGS ARE NOT TO BE TIGHTENED MORE THAN JUST SNUG.
- 5) FOR ADJUSTMENT PURPOSES THE KNOBS: ARE LOOSENED, THE (2) TWO MACHINES ARE ALIGNED AS NECESSARY AND THE (2) KNOBS ARE RETIGHTENED.

