

THE ATWOOD ROTARY KNIFE DIVIDER

AUTOMATIC BAGEL DIVIDING

MODEL: RK2001

INCLUDES: RK2100 SERIES MACHINES

OPERATIONS AND SAFETY MANUAL

INCLUDING PARTS CATALOG
AND MAINTENANCE INSTRUCTIONS

MODEL No. _____

SERIAL No. _____



CAUTION:

DO NOT OPERATE, CLEAN OR SERVICE THIS MACHINE BEFORE YOU READ THIS MANUAL, AND ARE FAMILIAR WITH THE SAFETY INSTRUCTIONS IN THIS MANUAL AND THOSE ON THE LABELS ON THE MACHINE. KEEP THIS MANUAL AND OTHER MATERIALS DELIVERED WITH THE MACHINE, ACCESSIBLE TO THE OPERATORS FOR EASY REFERENCE DURING USE.

IF YOU SHOULD HAVE ANY (?)
QUESTIONS ABOUT GUARDS OR
PLACEMENT CALL (708) 841-0959.

THE ENTIRE CONTENTS OF THIS PUBLICATION
ARE COPYWRITTEN AND ALL RIGHTS ARE
RESERVED. REPRODUCTION IN WHOLE OR IN
PART IS PROHIBITED WITHOUT WRITTEN
PERMISSION OF A.M. MFG. INC.

THIS CATALOG BECOMES OBSOLETE ON
12/31/00. UPDATED CATALOGS ARE AVAILABLE
DIRECTLY FROM A.M. MFG. INC.



MANUFACTURING COMPANY

DIVISION OF THE ATWOOD CORPORATION
14151 IRVING AVENUE DOLTON, ILLINOIS 60419

(773) 785-3177 (708) 841-0959 (800) 342-6744 FAX: (708) 841-0975 www.ammfg.com

© COPYRIGHT 1996

OWNERS RESPONSIBILITY

NOTE:

THE PARTS AND EQUIPMENT DESCRIBED IN THIS MANUAL MAY BE COVERED BY ONE OR MORE U.S. AND FOREIGN PENDING PATENTS.



TO MAINTAIN MACHINE AND USER SAFETY, THE RESPONSIBILITY OF THE OWNER IS TO READ AND FOLLOW THESE INSTRUCTIONS AND TO ENSURE THAT ALL OPERATORS UNDERSTAND AND FOLLOW THESE AND OTHER SAFETY INSTRUCTIONS IN THIS MANUAL.

- FOLLOW ALL INSTALLATION INSTRUCTIONS.
- MAKE SURE INSTALLATION CONFORMS TO ALL APPLICABLE LOCAL, STATE, AND FEDERAL CODES, RULES AND REGULATIONS SUCH AS STATE AND FEDERAL OSHA REGULATIONS AND ELECTRICAL CODES.
- CAREFULLY CHECK THE UNIT FOR CORRECT INITIAL FUNCTION.
- READ AND FOLLOW THE SAFETY INSTRUCTIONS. KEEP THEM READILY AVAILABLE FOR MACHINE OPERATORS.
- MAKE CERTAIN ALL OPERATORS ARE PROPERLY TRAINED, KNOW HOW TO SAFELY AND CORRECTLY OPERATE THE UNIT AND ARE PROPERLY SUPERVISED.
- ALLOW UNIT OPERATION ONLY WITH ALL PARTS INCLUDING SAFETY EQUIPMENT, IN PLACE AND OPERATING SAFELY.
- CAREFULLY INSPECT THE UNIT ON A REGULAR BASIS AND PERFORM ALL MAINTENANCE AS REQUIRED.
- SERVICE AND MAINTAIN THE UNIT ONLY WITH AUTHORIZED OR APPROVED REPLACEMENT PARTS.
- KEEP ALL INSTRUCTIONS PERMANENTLY WITH THE UNIT ALONG WITH ALL DECALS AND WARNING LABELS ON THE UNIT CLEAN AND VISIBLE.

TABLE OF CONTENTS

	<u>PAGE</u>
OWNERS RESPONSIBILITIES _____	INSIDE COVER
INTRODUCTION & SPECIFICATIONS & INSTALLATION _____	2
SAFETY SIGNAL WORDS _____	3
LOCATION OF WARNING LABELS _____	4
REPRODUCTION OF WARNING LABELS _____	5
GENERAL SAFETY INFORMATION / SAFETY RULES _____	6
OPERATING INSTRUCTIONS _____	7
GUIDE TO CLEANING _____	8
GUIDE TO MAINTENANCE _____	9-10
BELT REPLACEMENT _____	11-12
<u>PARTS CATALOG</u>	13
INFEED CONVEYOR ASSEMBLY _____	14
DISCHARGE CONVEYOR ASSEMBLY _____	15
CABINET ASSEMBLY _____	16-17
ROLLER ASSEMBLY _____	18-19
LEFT SIDE ASSEMBLY _____	20-21
RIGHT SIDE ASSEMBLY _____	22-23
ELECTRICAL SYSTEM _____	24-25
ELECTRICAL (SCHEMATIC 208 / 230 VOLTS (2001)) _____	26
ELECTRICAL (HARDWIRE 208 / 230 VOLTS (2001)) _____	27
ELECTRICAL (SCHEMATIC 208 / 230 VOLTS (2100)) _____	28
ELECTRICAL (HARDWIRE 208 / 230 VOLTS (2100)) _____	29
ORDERING REPLACEMENT PARTS _____	30
NOTES _____	31

IMPORTANT:

A.M. MANUFACTURING Co. RESERVES THE RIGHT TO MAKE CHANGES IN DESIGN, SPECIFICATIONS OR MANUFACTURING. TO IMPROVE THEIR PRODUCTS WITHOUT NOTICE AND WITHOUT OBLIGATION TO CHANGE OR IMPROVE PREVIOUSLY BUILT PRODUCTS INCLUDING MANUALS AND CATALOGS.

ONLY USE FACTORY SUPPLIED REPLACEMENT PARTS TO MAINTAIN MACHINE SAFETY, PERFORMANCE AND SANITARY CONDITIONS. USE OF NON-APPROVED PARTS MAY VOID MANUFACTURERS WARRANTY.

KNOW YOUR UNIT. COMPARE DIAGRAMS IN THIS MANUAL WITH THE UNIT BEFORE STARTING SERVICE, TO OBTAIN MAXIMUM SAFETY AND PERFORMANCE.

TO ORDER REPLACEMENT PARTS:
TURN TO PAGE 30 OF THIS MANUAL.



WARNING:

THIS MANUAL CONTAINS CRITICAL SAFETY INSTRUCTIONS. READ AND FOLLOW THEM CAREFULLY. FAILURE TO FOLLOW WARNING AND INSTRUCTIONS MAY LEAD TO SERIOUS PERSONAL INJURY. THE OWNER IS RESPONSIBLE FOR MAINTAINING THE UNIT, ITS INSTRUCTIONS AND DECALS FOR OPERATION REFERENCE. FOR ADDITIONAL COPIES CONTACT A.M. MANUFACTURING: (800)342-6744

OPERATIONS AND SAFETY MANUAL

INCLUDING PARTS CATALOG

**READ AND FAMILIARIZE YOURSELF WITH THIS MANUAL BEFORE OPERATING THIS MACHINE
FOLLOW INSTRUCTIONS DURING USE**

INTRODUCTION

THE MODEL RK-2001 FROM A.M. MANUFACTURING IS A SINGLE BANK, ROTATING KNIFE DIVIDER. IT CAN ACHIEVE OUTPUT SPEEDS OF UP TO 4800 PIECES PER HOUR (DEPENDING ON SIZE), ALLOWING GREATER BAGEL PRODUCTION. IT'S VERSATILE YET SIMPLE DESIGN MAKE IT BOTH LABOR SAVING AND COST EFFECTIVE. STUDY THIS OPERATION AND SAFETY MANUAL FOR FULL BENEFITS.



CAUTION:

ALL OPERATORS MUST BE FULLY TRAINED AND INSTRUCTED IN SAFETY PROCEDURES BEFORE BEGINNING PRODUCTION.

SPECIFICATIONS

PRODUCTION RATE	225 TO 400 DOZEN PER HOUR (DEPENDING ON SIZE)
HEIGHT	64"
LENGTH	71" (WITH STANDARD INFEEED CONVEYOR)
WIDTH	18 1/2"
SHIPPING WEIGHT	500 lbs.
STANDARD INFEEED CONVEYOR LENGTH	48"
HEIGHT OF INFEEED CONVEYOR LENGTH	37" (TO BOTTOM OF CONVEYOR)
ELECTRICAL REQUIREMENTS	208/220 VOLT - SINGLE PHASE (1 H.P. DIVIDER MOTOR)

ALL MOVING PARTS, WITH EXCEPTION OF NECESSARY CONVEYING SURFACES ARE COVERED AND GUARDED...

INSTALLATION INSTRUCTIONS

LOCATION:

SELECT LOCATION CAREFULLY. THE AREA SHOULD PROVIDE THE OPERATOR WITH ENOUGH SPACE TO USE THE EQUIPMENT IN A SAFE MANNER. THE FLOOR AREA SELECTED SHOULD BE EASY TO CLEAN AND SHOULD BE FREE OF OIL, GREASE, ETC. AVOID AREAS WHERE BYSTANDERS AND CUSTOMERS MAY BE PRESENT.



CAUTION

PROPER UNIT INSTALLATION IS NECESSARY FOR SAFE AND EFFICIENT OPERATION. PROPER INSTALLATION ALSO HELPS PROTECT THE UNIT FROM DAMAGE AND MAKES SERVICE EASIER.

SAFETY

THIS MACHINE IS DESIGNED TO PROVIDE FOR SAFE OPERATION IF NORMAL OPERATING PROCEDURES AND SAFETY MESSAGES LOCATED ON THE MACHINE AND IN THIS MANUAL ARE FOLLOWED.



THIS IS A SAFETY ALERT SYMBOL. YOU WILL FIND IT ON VARIOUS SAFETY LABELS ON THE MACHINE AND IT WILL ALSO APPEAR IN THIS MANUAL WHEREVER SAFETY MESSAGES ARE GIVEN.

GET FAMILIAR WITH SIGNAL WORDS:

CAUTION, WARNING & DANGER

CAUTION:

INDICATES A POTENTIALLY HAZARDOUS SITUATION WHICH, IF NOT AVOIDED, MAY RESULT IN MINOR OR MODERATE INJURY. IT MAY ALSO BE USED TO ALERT AGAINST UNSAFE PRACTICES.

WARNING:

INDICATES A POTENTIALLY HAZARDOUS SITUATION WHICH, IF NOT AVOIDED, COULD RESULT IN DEATH OR SERIOUS INJURY.

DANGER:

INDICATES AN IMMINENTLY HAZARDOUS SITUATION WHICH, IF NOT AVOIDED, WILL RESULT IN DEATH OR SERIOUS INJURY. THIS SIGNAL WORD IS TO BE LIMITED TO THE MOST EXTREME SITUATIONS.

NOTE:

A NOTE PROVIDES KEY INFORMATION TO MAKE PROCEDURES EASIER AND CLEARER.

TYPICAL WARNING LOCATIONS

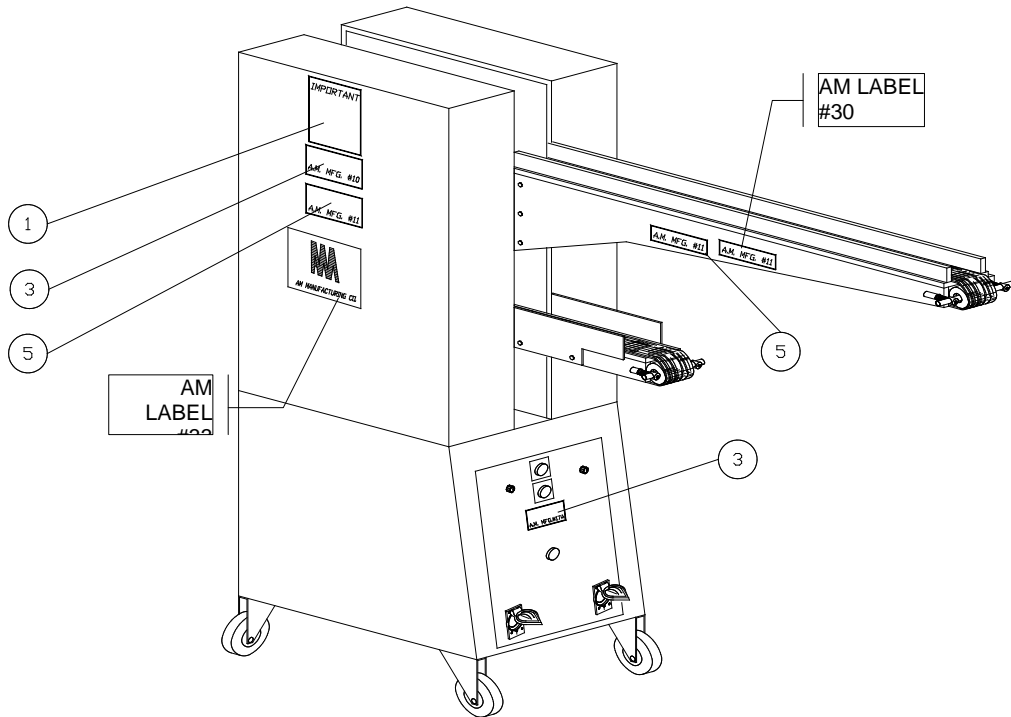
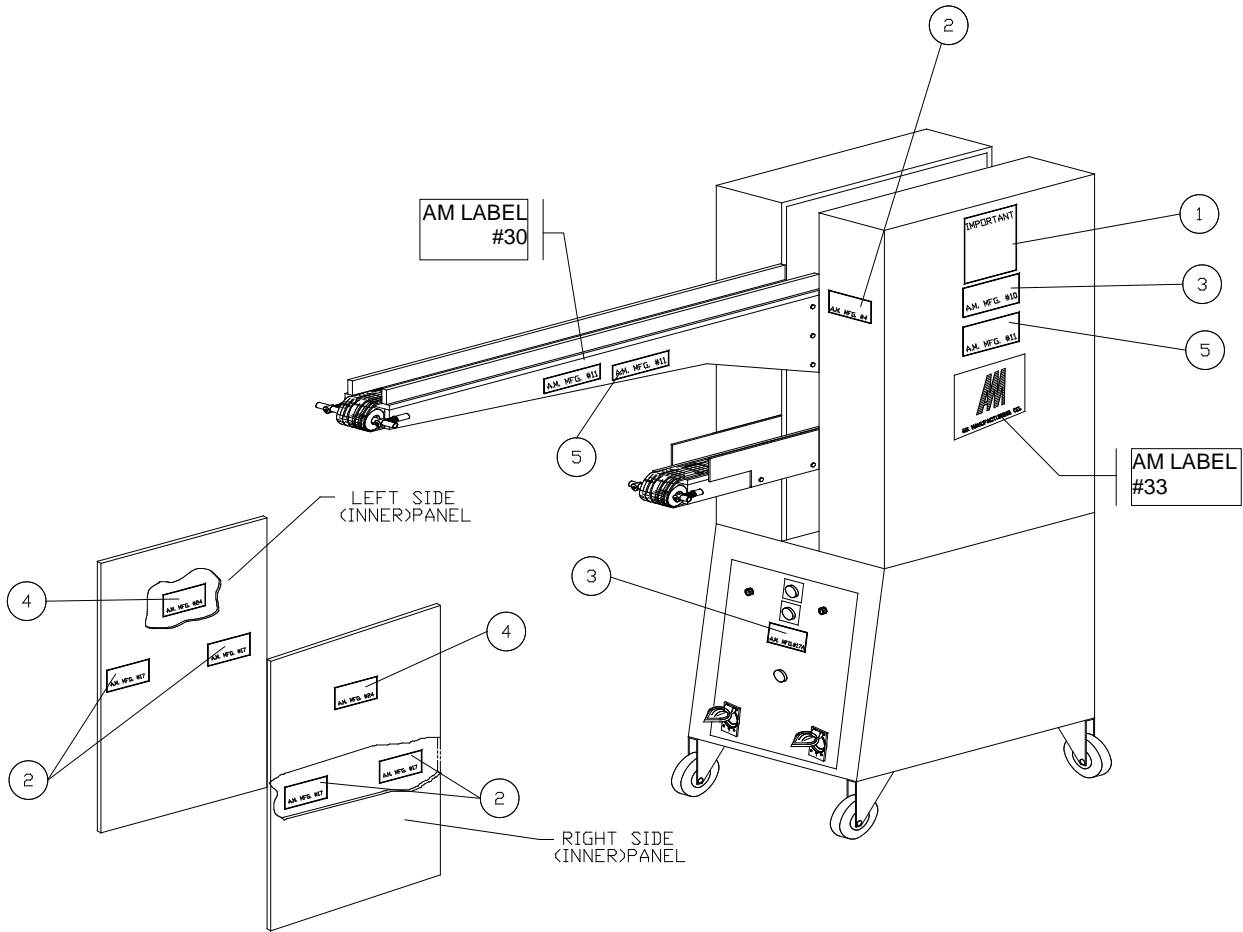

SAFETY RULES



IMPORTANT:

READ AND FOLLOW THESE SAFETY RULES. THEY ARE FOR YOUR PROTECTION AND THE PROTECTION OF THOSE WORKING WITH YOU.

- DO NOT OPERATE THIS MACHINE BEFORE YOU READ AND UNDERSTAND THE OPERATIONS AND SAFETY MANUAL.
- FOLLOW ALL INSTRUCTIONS DURING USE OF THIS MACHINE.
- LEAVE ALL GUARDS IN PLACE. INSTALL ALL GUARDS IF THEY WERE REMOVED FOR CLEANING, MAINTENANCE, REPAIR OR OTHER REASONS.
- NEVER OPERATE THE MACHINE IF YOU HAVE NOT BEEN TRAINED TO OPERATE THE MACHINE PROPERLY.
- NEVER OPERATE THE MACHINE IF YOU ARE TIRED, ILL, ON MEDICATION, OR UNDER THE INFLUENCE OF ALCOHOL OR DRUGS.
- WEAR TIGHT FITTING CLOTHES. MAKE SURE THAT LONG HAIR, JEWELRY, OR LOOSE PERSONAL ITEMS ARE SECURED SO THEY CANNOT GET CAUGHT IN THE MACHINE. THIS CAN LEAD TO SERIOUS INJURIES.
- MAKE SURE YOU CAN EASILY REACH ALL CONTROLS. IF NOT, A STABLE AND SAFE ELEVATED PLATFORM OR OTHER WORK-AID MUST BE PROVIDED.
- ALWAYS DISCONNECT THE MAIN ELECTRICAL POWER SOURCE BEFORE CLEANING, IF MAINTENANCE OR SERVICE IS PERFORMED, OR IF THE MACHINE IS OUT OF SERVICE.
- NEVER CLEAN BELTS ON MACHINE, ALWAYS REMOVE BELT FROM MACHINE TO CLEAN OR SERVICE (WHEN APPLICABLE).
- NEVER LEAVE THIS MACHINE RUNNING UNATTENDED.
- GUARDS ARE INTERLOCKED, MACHINE WILL NOT OPERATE WITHOUT GUARDS IN PLACE.

IMPORTANT:

IF YOU HAVE ANY QUESTIONS ABOUT THESE SAFETY RULES, SEE YOUR SUPERVISOR OR CALL A.M. MANUFACTURING Co. TOLL FREE: (800)342-6744

OPERATING INSTRUCTIONS



WARNING:

UNIT MUST BE PROPERLY OPERATED AND MAINTAINED TO PREVENT MACHINE DAMAGE OR PERSONAL INJURY. REVIEW INSTRUCTIONS WITH ALL EMPLOYEES BEFORE USE.



CAUTION:

MAGNETIC REED SWITCH (PART NO. SS240).

THESE PARTS ARE LOCATED ON (3) THREE AREAS OF THE MACHINE, AS DESCRIBED ON PAGES 16, 17 & 25. THE LOCATIONS ARE AS FOLLOWS: RIGHT AND LEFT SIDES OF BASE CABINET FRAME, INSIDE RIGHT AND LEFT SIDE CASES / BASE OF REAR CABINET DOOR AND FRAME. THESE SWITCHES ARE LOCATED AT POINTS ON THE MACHINE WHERE EASY ACCESS IS KNOWN. IF THE CONTACT BETWEEN THE (2) TWO REED SWITCHES ARE BROKEN OR DISRUPTED IN ANY WAY, THIS WILL AUTOMATICALLY DISCONNECT POWER TO THE MACHINE AND THE MACHINE WILL NOT RUN. TO AVOID THIS PROBLEM, LEAVE SIDE PANELS ON THE MACHINE AND KEEP REAR DOOR CLOSED AT ALL TIMES WHILE MACHINE IS RUNNING.

I. PRELIMINARY START-UP PROCEDURE

- A. PLUG POWER CORD INTO PROPER RECEPTACLE.
- B. INSPECT MACHINE FOR ANY DAMAGES.

II. OPERATING OF THE DIVIDER

- A. SET WEIGHT AND SPEED CONTROLS TO 50% (SEE FIGURE 2).
- B. HAVE YOUR DOUGH READY NEXT TO MACHINE AND COVER TO AVOID SURFACE SKIN. THIS CAN CAUSE DOUGH TO SLIDE THROUGH FORMER.
- C. HAVE DOUGH ALREADY CUT INTO STRIPS OF APPROXIMATELY 3" DIAMETER, BY A MAXIMUM OF 4 FT. LONG. MAKE SURE THERE IS ABOUT 1/4" OF SPACE BETWEEN THE STRIPS OF DOUGH AND THE SIDE WALLS OF THE CONVEYOR, SO DOUGH DOES NOT CATCH AND BIND.
- D. REPEAT STEP 3 AND REPEAT PROCESS.

NOTE:

FOR MORE ACCURATE RESULTS MAKE SURE THE STRIPS CUT WILL BE PLACED SO THAT THE END OF THE FRONT STRIP IS OVERLAPPING BY THE FRONT OF THE TRAILING STRIP. SEE FIGURE 1.

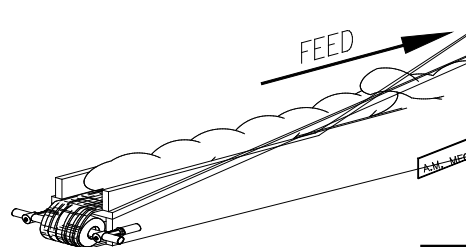

FIGURE 1

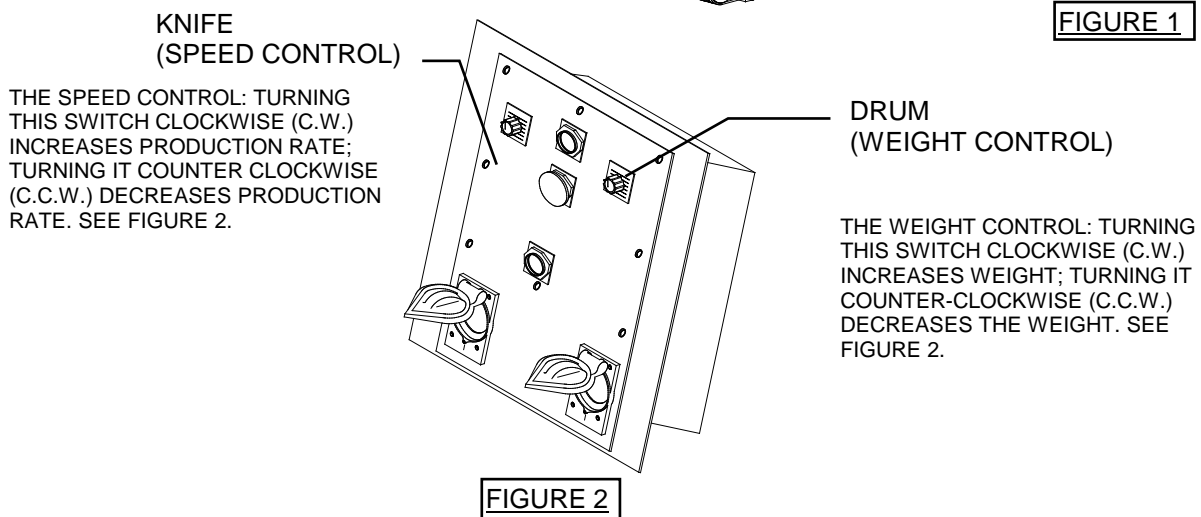

FIGURE 2

CLEANING PROCEDURES

THESE PROCEDURES ARE VERY IMPORTANT TO MAINTAIN PRODUCT QUALITY AND MACHINE PERFORMANCE.

A MESSAGE FROM THE MANUFACTURER:

ALL A.M. MANUFACTURING MACHINE ARE TESTED WITH DOUGH DURING THE IN-HOUSE RUN-IN AND QUALITY AUDIT PROCEDURE. ALTHOUGH THE MACHINE HAS BEEN CLEANED, SOME EVIDENCE OF DOUGH ON AND IN THE MACHINE MAY BE DETECTED. THIS IS NORMAL.

I. DIVIDER



1. **CAUTION: ALWAYS DISCONNECT ELECTRICAL POWER SOURCE WHEN CLEANING, MAINTAINING OR REPAIRING THIS MACHINE..**
2. USING A SOAP SOLUTION WIPE DOWN OUTSIDE OF CABINET TO EXPOSE ALL WARNING LABELS TO ALERT ALL EMPLOYEES OF ANY POSSIBLE HAZARDS.



WARNING: CONVEYOR MAINTENANCE SHALL BE PERFORMED ONLY WHEN CONVEYOR IS STOPPED, AND ALL POWER IS OFF AND LOCKED OUT.

3. CONTINUE TO WIPE DOWN BOTH CONVEYORS ENTIRELY. THIS IS TO REMOVE ANY DOUGH BUILD - UP THAT OCCURS UNDER THE BELTS AND ON THE INTERIOR WALLS OF THE CONVEYORS.

NOTE: THIS ALSO HELPS PREVENT BELT SLIPPAGE THAT MAY OCCUR.

4. OPEN REAR INSPECTION DOOR.
5. USING A SOAP SOLUTION, WIPE DOWN THE DRUM SCRAPER AND KNIFE FROM THE EXCESS DOUGH BUILD - UP THAT OCCURS.

NOTE:

YOU MAY HAVE TO ACTUALLY SCRAPE SOME DOUGH FROM THE DRUM SCRAPER AND KNIFE BY HAND TO THOROUGHLY CLEAN THESE COMPONENTS.



PRACTICE SAFETY FIRST:

ALWAYS DISCONNECT ELECTRICAL SERVICE WHEN CLEANING OR MAINTAINING THIS MACHINE, THUS AVOIDING CHANCE OF SERIOUS INJURIES. MACHINES ARE NOT DANGEROUS IF COMMON SENSE IS APPLIED AND THE INSTRUCTIONS ARE CAREFULLY FOLLOWED. THINK AND PRACTICE SAFETY FIRST.

MAINTENANCE PROCEDURES

THESE PROCEDURES ARE VERY IMPORTANT TO MAINTAIN PRODUCT QUALITY AND MACHINE PERFORMANCE...



PRACTICE SAFETY FIRST

ALWAYS DISCONNECT ELECTRICAL SERVICE WHEN CLEANING OR MAINTAINING THIS MACHINE, THUS AVOIDING CHANCE OF SERIOUS INJURIES. MACHINES ARE NOT DANGEROUS IF COMMON SENSE IS APPLIED AND THAT THE INSTRUCTIONS ARE CAREFULLY FOLLOWED. THINK AND PRACTICE SAFETY FIRST.

READ AND FOLLOW MAINTENANCE INSTRUCTIONS BELOW TO HELP KEEP THE UNIT IN GOOD OPERATING CONDITION. REFER TO OTHER MATERIALS RECEIVED WITH THE UNIT AND TO SERVICE AND SAFETY BULLETINS FROM THE MANUFACTURER FOR ADDITIONAL INSTRUCTIONS FOR PROPER MAINTENANCE AND SERVICE. REGULAR INSPECTIONS AND PROPER MAINTENANCE ARE ESSENTIAL TO HELP PREVENT ACCIDENTS AND INJURIES.

I. DIVIDER



DANGER: ALWAYS DISCONNECT ELECTRICAL POWER SOURCE WHEN CLEANING, MAINTAINING OR REPAIRING THIS MACHINE...



WARNING: BEFORE MAKING ANY INSPECTION, ADJUSTMENT OR REPAIR, BE CERTAIN POWER SOURCE IS DISCONNECTED AND ALL MOVING PARTS ARE BLOCKED OUT TO PREVENT INJURY. WEAR PROTECTIVE CLOTHING.

- A. MAKE CERTAIN THAT ALL GUARDS AND COVERS ARE IN PLACE.
- B. CHECK FOR WORN, DAMAGED OR MISSING PARTS INCLUDING: BELTS, SAFETY GUARDS AND PROTECTIVE COVERS.
- C. MAKE SURE THAT ALL FASTENERS ARE TIGHTENED SECURELY.
- D. ON A DAILY BASIS, INSPECT THE UNIT AND CHECK TO BE CERTAIN THAT ALL SYSTEMS ARE OPERATING NORMALLY. DETAILED INSPECTION AND TESTING PROCEDURES ARE SPECIFIED FOR VARIOUS COMPONENTS AT REGULAR INTERVALS. SET UP A CHART AND ASSIGN RESPONSIBILITY FOR THESE ITEMS.



CAUTION: REPLACE ANY DAMAGED OR MISSING SAFETY LABELS. THEY ARE AVAILABLE FROM THE MANUFACTURER.

IMPORTANT:

MAINTENANCE FOR THE ROTARY KNIFE DIVIDER - 2001 ALWAYS BEGINS WITH KEEPING THE MACHINE CLEAN. PROPER CLEANING PROCEDURES CAN BE FOUND ON PAGE (8) OF THIS MANUAL. STANDARD LONG-TERM MAINTENANCE CONSISTS OF LUBRICATING MAIN WEAR POINTS OF THE WITH AN ALL-PURPOSE LITHIUM BASE GREASE. A GREASE GUN WITH A FLEXIBLE HOSE IS NEEDED.

NOTE:

ALL RECOMMENDATIONS FOR MAINTENANCE, BASED ON A 7 DAY, 8 HOUR PER DAY WORK SCHEDULE. HEAVIER WORK SCHEDULES WILL REQUIRE MORE FREQUENT MAINTENANCE.

MAINTENANCE PROCEDURES

⚠ DANGER: ALWAYS DISCONNECT ELECTRICAL POWER SOURCE WHEN CLEANING, MAINTAINING OR REPAIRING THIS MACHINE...

THE FIRST STEP IS TO REMOVE THE TWO (2) CABINET COVERS (PART NO. K609C). ONCE YOU HAVE COMPLETED THIS STEP YOU SHOULD BE ABLE TO VIEW ALL FOUR (4) CHAIN DRIVES OF THE MACHINE. TWO (2) CHAINS ON THE LEFT SIDE OF THE MACHINE, ONE (1) ON THE RIGHT SIDE AND ONE (1) FROM THE MAIN DRIVE MOTOR (PART NO. SS259).

LOCATE THE RIGHT SIDE OF THE MACHINE (FIGURE 1). THIS SIDE WILL HAVE THE SINGLE DRIVE CHAIN. YOU WILL NOTICE THE NINE (9) BEARING FLANGES, EIGHT (8) TWO (2) HOLE FLANGES AND ONE (1) FOUR (4) HOLE FLANGE. WITH A GREASE GUN, APPLY A SMALL AMOUNT OF GREASE TO THE FITTINGS. YOU WILL ALSO NOTICE A GREASE FITTING COMING OFF (PART NO. K203RS) NEAR THE MIDDLE OF THIS PANEL. THIS MAKES A TOTAL OF TEN (10) GREASE FITTINGS FOR THE RIGHT SIDE.

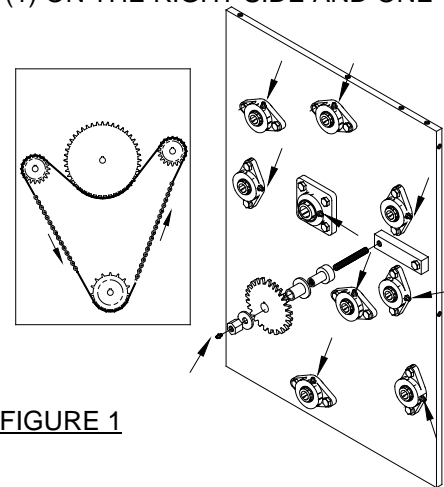

FIGURE 1

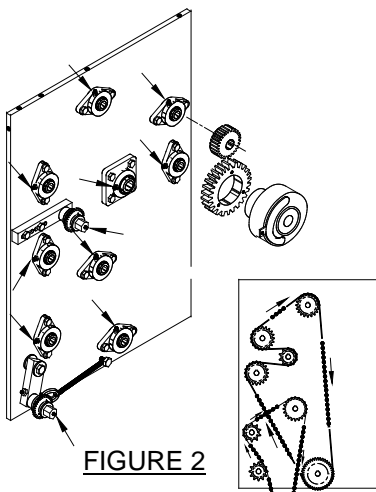

FIGURE 2

NOTE:
 →
 INDICATES
 GREASE POINT

LOCATE THE LEFT SIDE OF THE MACHINE (FIGURE 2). THIS SIDE WILL HAVE TWO (2) DRIVE CHAINS. REPEAT THE ABOVE STEP FOR ALL FLANGE BEARINGS SINCE THEY ARE IDENTICAL TO THE RIGHT SIDE OF THE MACHINE. ONLY ON THIS SIDE THERE WILL BE TWO (2) MORE GREASE FITTINGS. ONE (1) COMING OFF (PART NO. K203RS) AND THE OTHER GREASE FITTING COMING OFF (PART # K104LS), THESE ARE BOTH TENSION BARS.

ALL GREASE FITTINGS SHOULD BE GREASED ONCE A WEEK.

THE ROTARY KNIFE DIVIDER - 2001, HAS FOUR (4) DRIVE CHAINS (PART NO.'S K124LS/K125LS/K209LS/K332RA). THESE PARTS MUST BE OILED REGULARLY WITH A LIGHT WEIGHT MACHINE OIL TO PROLONG LIFE OF THE SPROCKETS AS WELL AS THE DRIVE CHAINS. THOROUGHLY LUBRICATE EACH DRIVE CHAIN. THE NORMAL OPERATION OF THE MACHINE WILL EVENLY DISTRIBUTE THE OIL OVER THE ENTIRE CHAIN AND SPROCKETS. THIS PROCEDURE MUST BE REPLACED ONCE A WEEK.

NOTE:
 CHAIN CONDITION AND TENSION SHOULD BE CHECKED WHEN OILING PROCEDURE IS ACCOMPLISHED.

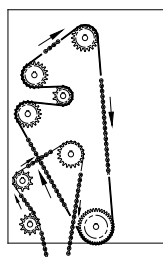

LEFT SIDE

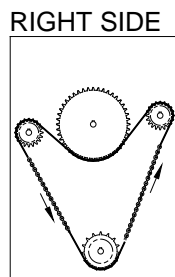

RIGHT SIDE

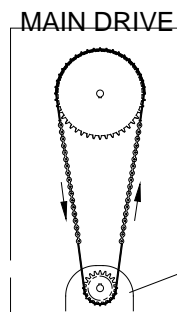

MAIN DRIVE

MAIN DRIVE MOTOR

MAINTENANCE PROCEDURES

BELT REPLACEMENT

WARNING: CONVEYOR MAINTENANCE SHALL BE PERFORMED ONLY WHEN THE POWER SUPPLY HAS BEEN DISCONNECTED AND LOCKED OUT AND THE CONVEYOR HAS STOPPED.

DISCHARGE CONVEYOR BELT REPLACEMENT:

TO REPLACE THE DISCHARGE CONVEYOR BELT UNPLUG THE MACHINE FROM ITS PROPER RECEPTACLE TO ENSURE ALL POWER IS OFF.

- I. TO LOOSEN THE BELT FOR REMOVAL FIND (PART NO. 600SC) ROLLER SUPPORT BOLTS WITH (PART NO. F0601HN) ADJUSTING HEX NUT. TURN ADJUSTING HEX NUT COUNTER CLOCK-WISE. THIS IN TURN WILL BRING IN THE ROLLER AND LOOSEN THE BELT. THIS PROCEDURE MUST BE DONE TO BOTH SIDES OF THE BELT. (SEE FIGURE 2).

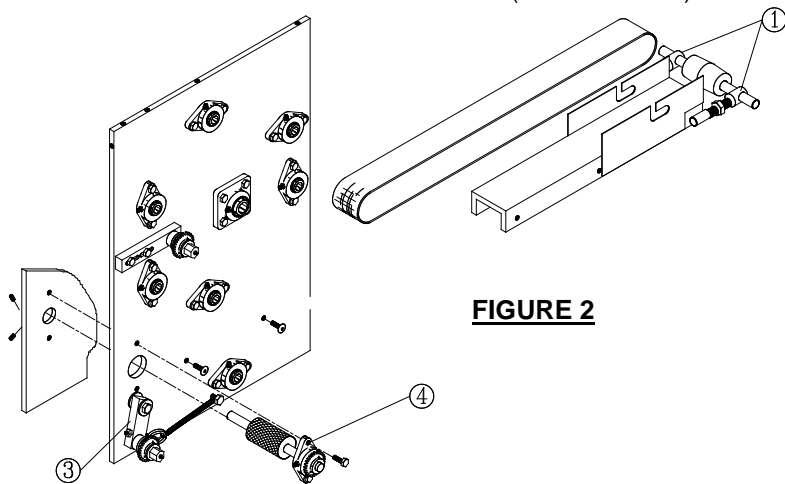
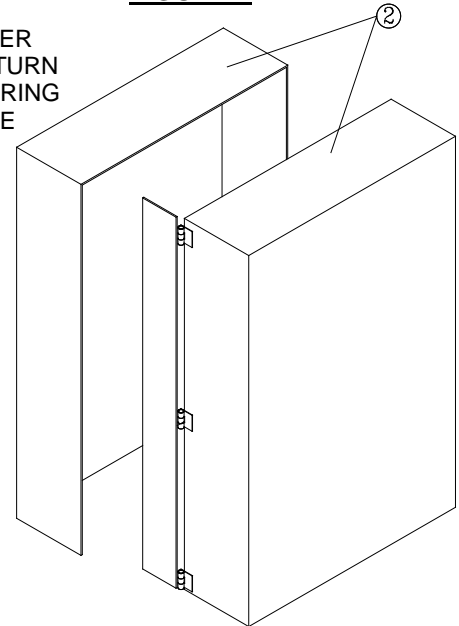

FIGURE 2

FIGURE 1



- II. REMOVE CABINET COVERS (PART NO.'S K609AC & K609C) FROM MACHINE TO EXPOSE INNER PANELS OF THE DIVIDER. (SEE FIGURE 1).
- III. LOCATE (PART NO. K203RS) TENSION BLOCK (ITEM #18) ON LEFT SIDE ASSEMBLY. RELEASE TENSION SPRING (PART NO. K120LS) (SEE FIGURE 2). THIS WILL ALLOW SLACK IN THE CHAIN (PART NO. K125LS) (ITEM #43) ON LEFT SIDE ASSEMBLY. NOW LOCATE MASTER-LINK IN CHAIN, REMOVE AND REMOVE CHAIN FROM AROUND SPROCKETS. (SEE FIGURE 3).
- IV. LOCATE THE FLANGE BEARING (PART NO. VF2S-212) (ITEM #12) ON LEFT SIDE ASSEMBLY THAT THE DISCHARGE CONVEYOR END SHAFT (PART NO. K307RA) (ITEM #5) ON DISCHARGE CONVEYOR ASSEMBLY IS GOING THRU. REMOVE THE TWO (2) HEX HEAD BOLTS THAT HOLD THE FLANGE BEARING TO THE LEFT SIDE PANEL. (SEE FIGURE 2).

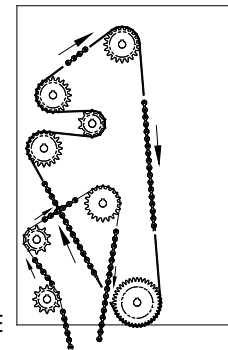



FIGURE 3

SWITCH TO THE RIGHT SIDE PANEL AND DIRECTLY ACROSS IS THE OTHER FLANGE BEARING THAT THE END SHAFT (PART NO. K307RA) IS GOING THRU. (SEE FIGURE 2). LOOSEN THE TWO (2) SET SCREWS ON THE BEARING (NOT THE TWO (2) HEX BOLTS!). NOW TAKE A RUBBER Mallet AND GENTLY HIT THE END OF THE SHAFT TO PUSH IT THRU TO THE LEFT SIDE. REMOVE ENTIRE ROLLER ASSEMBLY AND PLACE IT NEXT TO MACHINE IN A CLEAN AREA.

- V. LOCATE (PART NO. F0405SH) THIS WILL BE (ITEM 43) ON THE LEFT SIDE ASSEMBLY AND (ITEM #22) ON THE RIGHT SIDE ASSEMBLY. THERE WILL BE FOUR (4) TOTAL TWO (2) ON EACH SIDE. WITH AN ALLEN WRENCH AND A REGULAR WRENCH TO HOLD THE HEX NUTS ON THE INSIDE, REMOVE THESE (4) BOLTS. NOW YOU CAN REMOVE THE DISCHARGE CONVEYOR. REMOVE BELT (PART NO. K414CADC). TO REASSEMBLE THE DISCHARGE CONVEYOR, REPLACE THE NEW BELT AROUND THE CONVEYOR AND PLACE THE CONVEYOR BACK BETWEEN THE PANELS. NOW REVERSE THE ABOVE PROCEDURES FOR EASY ASSEMBLY.

MAINTENANCE PROCEDURES

BELT REPLACEMENT

 **WARNING:** CONVEYOR MAINTENANCE SHALL BE PERFORMED ONLY WHEN THE POWER SUPPLY HAS BEEN DISCONNECTED AND LOCKED OUT AND THE CONVEYOR HAS STOPPED.

INFEED CONVEYOR BELT REPLACEMENT

TO REPLACE THE IN-FEED CONVEYOR BELT UNPLUG THE MACHINE FROM IT'S PROPER RECEPTACLE TO ENSURE ALL POWER IS OFF.

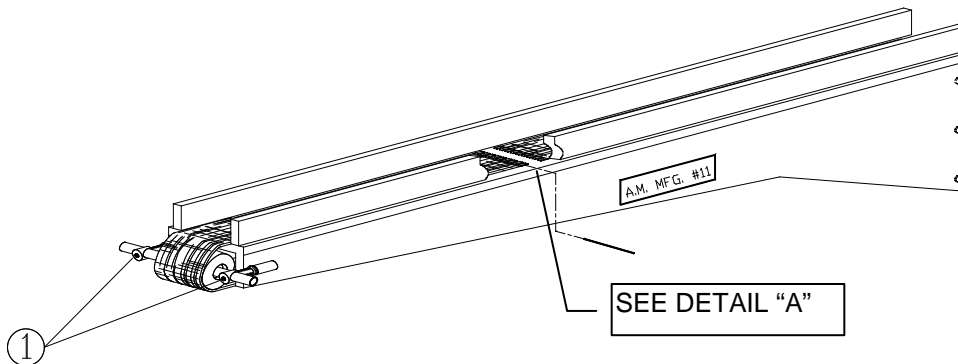

- I. TO LOOSEN THE BELT FOR REMOVAL FIND (PART NO. 600SC) ROLLER SUPPORT BOLTS WITH (PART NO. F0601HN) ADJUSTING HEX NUT. TURN ADJUSTING HEX NUT COUNTER CLOCK-WISE. THIS IN-TURN WILL BRING IN THE ROLLER AND LOOSEN THE BELT. THIS PROCEDURE MUST BE DONE TO BOTH SIDES OF THE BELT.
- II. TO REMOVE THE BELT FROM THE CONVEYOR, FIRST LOCATE THE ALLIGATOR LACING OR HINGE. YOU WILL SEE A PIN GOING THRU THE LACING. WITH PLIERS PULL THE PIN OUT. THE BELT WILL THEN COME APART, REMOVE BELT FROM MACHINE.
- III. TO REPLACE CONVEYOR BELT, FEED THE NEW BELT DOWN THE CONVEYOR AND AROUND BOTH ROLLERS. FIND THE ALLIGATOR LACING OR HINGE, INTERTWINE THE LACING AND SLIDE PIN THROUGH. TO TIGHTEN THE BELT, TURN THE ADJUSTING HEX NUTS (PART NO. F0601HN) CLOCK-WISE TO RE-TIGHTEN THE BELT.

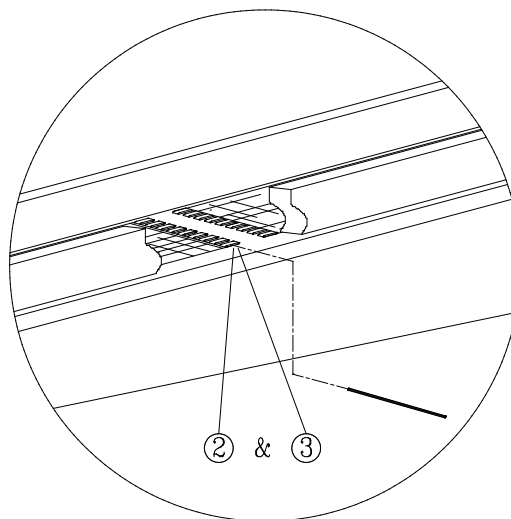

DETAIL "A"

PARTS CATALOG

	<u>PAGE</u>
<u>PARTS CATALOG</u>	13
<u>INFEED CONVEYOR ASSEMBLY</u> _____	14
<u>DISCHARGE CONVEYOR ASSEMBLY</u> _____	15
<u>CABINET ASSEMBLY</u> _____	16-17
<u>ROLLER ASSEMBLY</u> _____	18-19
<u>LEFT SIDE ASSEMBLY</u> _____	20-21
<u>RIGHT SIDE ASSEMBLY</u> _____	22-23
<u>ELECTRICAL SYSTEM</u> _____	24-25
<u>ELECTRICAL (SCHEMATIC 208 / 230 VOLTS (2001))</u> _____	26
<u>ELECTRICAL (HARDWIRE 208 / 230 VOLTS (2001))</u> _____	27
<u>ELECTRICAL (SCHEMATIC 208 / 230 VOLTS (2100))</u> _____	28
<u>ELECTRICAL (HARDWIRE 208 / 230 VOLTS (2100))</u> _____	29
<u>ORDERING REPLACEMENT PARTS</u> _____	30
<u>NOTES</u> _____	31

IMPORTANT:

A.M. MANUFACTURING Co. RESERVES THE RIGHT TO MAKE CHANGES IN DESIGN, SPECIFICATIONS OR MANUFACTURING. TO IMPROVE THEIR PRODUCTS WITHOUT NOTICE AND WITHOUT OBLIGATION TO CHANGE OR IMPROVE PREVIOUSLY BUILT PRODUCTS INCLUDING MANUALS AND CATALOGS.

ONLY USE FACTORY SUPPLIED REPLACEMENT PARTS TO MAINTAIN MACHINE SAFETY, PERFORMANCE AND SANITARY CONDITIONS. USE OF NON-APPROVED PARTS MAY VOID MANUFACTURERS WARRANTY.

KNOW YOUR UNIT. COMPARE DIAGRAMS IN THIS MANUAL WITH THE UNIT BEFORE STARTING SERVICE, TO OBTAIN MAXIMUM SAFETY AND PERFORMANCE.

TO ORDER REPLACEMENT PARTS:
TURN TO PAGE 30 OF THIS MANUAL.



WARNING:

THIS MANUAL CONTAINS CRITICAL SAFETY INSTRUCTIONS. READ AND FOLLOW THEM CAREFULLY. FAILURE TO FOLLOW WARNING AND INSTRUCTIONS MAY LEAD TO SERIOUS PERSONAL INJURY. THE OWNER IS RESPONSIBLE FOR MAINTAINING THE UNIT, ITS INSTRUCTIONS AND DECALS FOR OPERATION REFERENCE. FOR ADDITIONAL COPIES CONTACT A.M. MANUFACTURING: (800)342-6744

INFEED CONVEYOR ASSEMBLY



IMPORTANT

KNOW YOUR UNIT. COMPARE DIAGRAMS IN THIS MANUAL WITH THE UNIT BEFORE STARTING SERVICE TO OBTAIN MAXIMUM SAFETY AND PERFORMANCE.

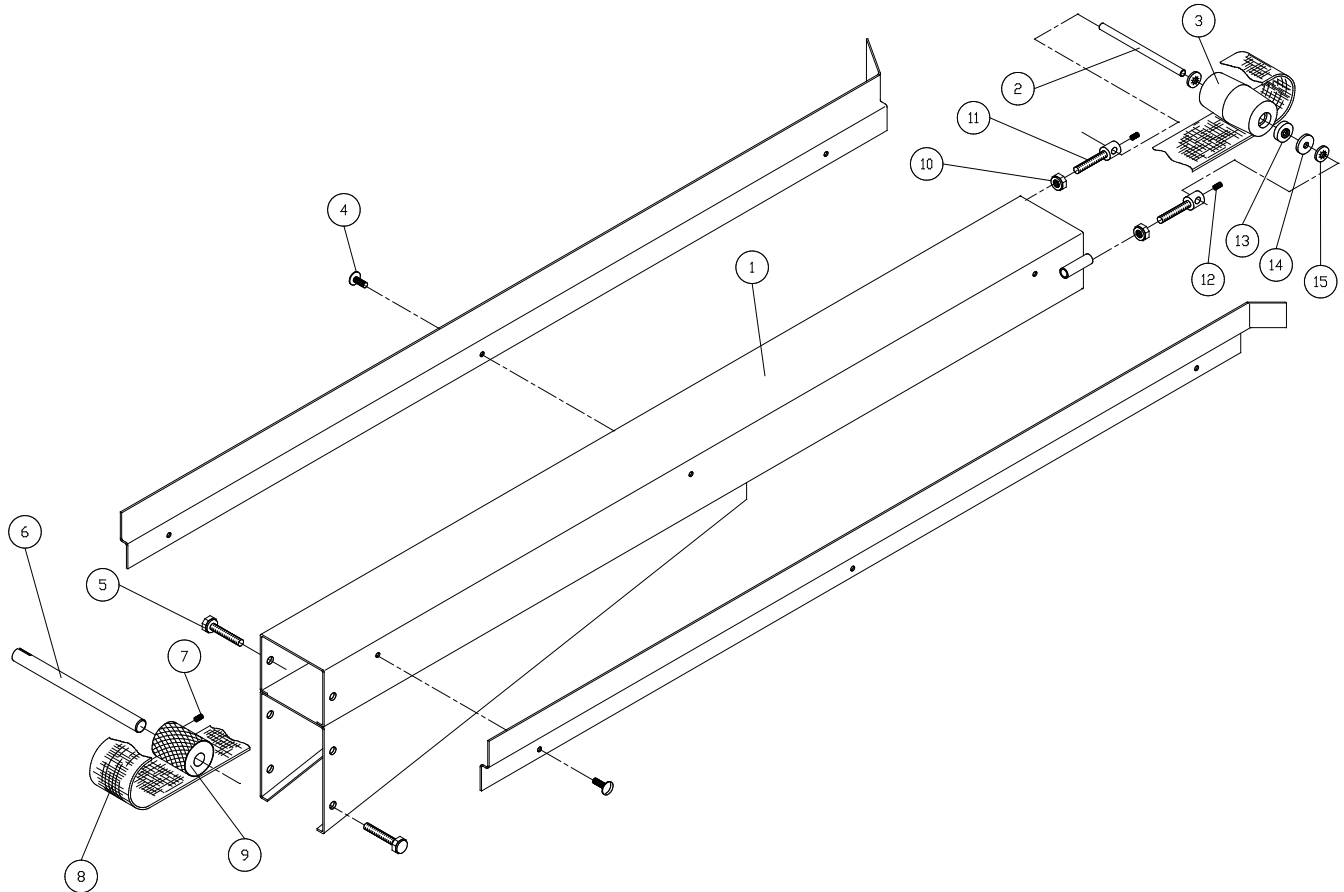

ITEM	PART NO.	DESCRIPTION	NO. REQ'D
1	K420CA	INFEED CONVEYOR W/ R & L SIDE RAILS	1
2	K401CADC	ROLLER CENTER SHAFT	1
3	K404CAIF	INFEED CONVEYOR ROLLER	1
4	F0402RH	BOLT	6
5	F0503HH	BOLT	6
6	K308RA	INFEED CONVEYOR SHAFT	1
7	F0502SS	SET SCREW	1
8	K415CA	STD. INFEED CONVEYOR BELT	1
9	K412CAIF	INFEED CONVEYOR DRIVE ROLLER	1
10	F0600LN	LOCK NUT	2
11	600SC	ROLLER SUPPORT BOLT	2
12	F0401SS	SET SCREW	2
13	641SC2	BEARING	2
14	F0600NW	NYLON WASHER	2
15	F0600RW	RETAINING WASHER	2

DISCHARGE CONVEYOR ASSEMBLY

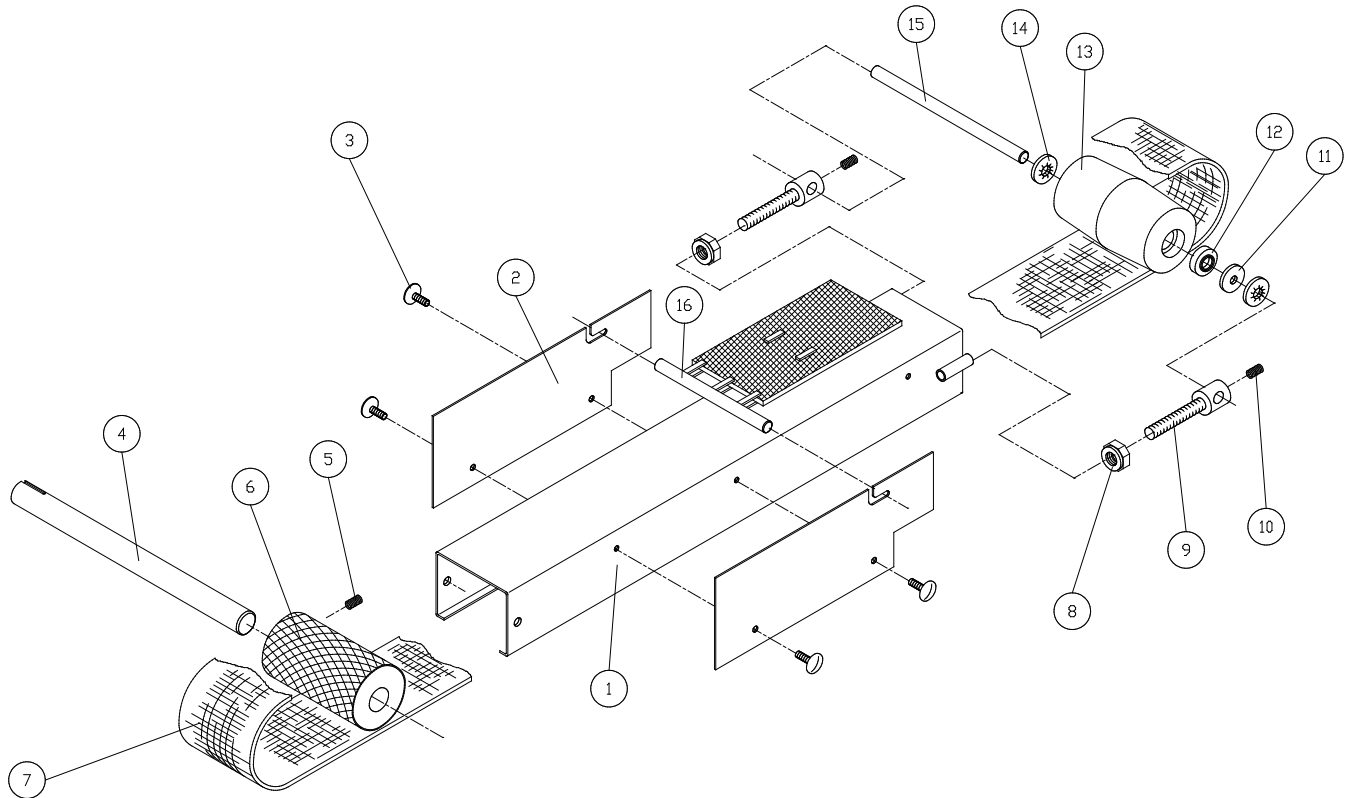

ITEM	PART NO.	DESCRIPTION	NO. REQ'D
1	K425CA	DISCHARGE CONVEYOR FRAME	1
2	K417CADC	DISCHARGE CONVEYOR SIDE PLATE	2
3	F0402RH	BOLT	4
4	K307RA	DISCHARGE CONVEYOR DRIVE SHAFT	1
5	F0502SS	SET SCREW	1
6	K413CADC	DISCHARGE CONVEYOR DRIVE ROLLER	1
7	K414CADC	STD. DISCHARGE CONVEYOR BELT	1
8	F0600LN	LOCK NUT	2
9	600SC	ROLLER SUPPORT BOLT	2
10	F0401SS	SET SCREW	2
11	F0600FW	FLAT WASHER (NYLON)	2
12	641SC2	BEARING	2
13	K405CADC	DISCHARGE CONVEYOR IDLE ROLLER	1
14	F0600RW	RETAINING WASHER	2
15	K401CADC	ROLLER CENTER SHAFT	1
16	K426CA	WIRE BELT ASSEMBLY	1

CABINET ASSEMBLY

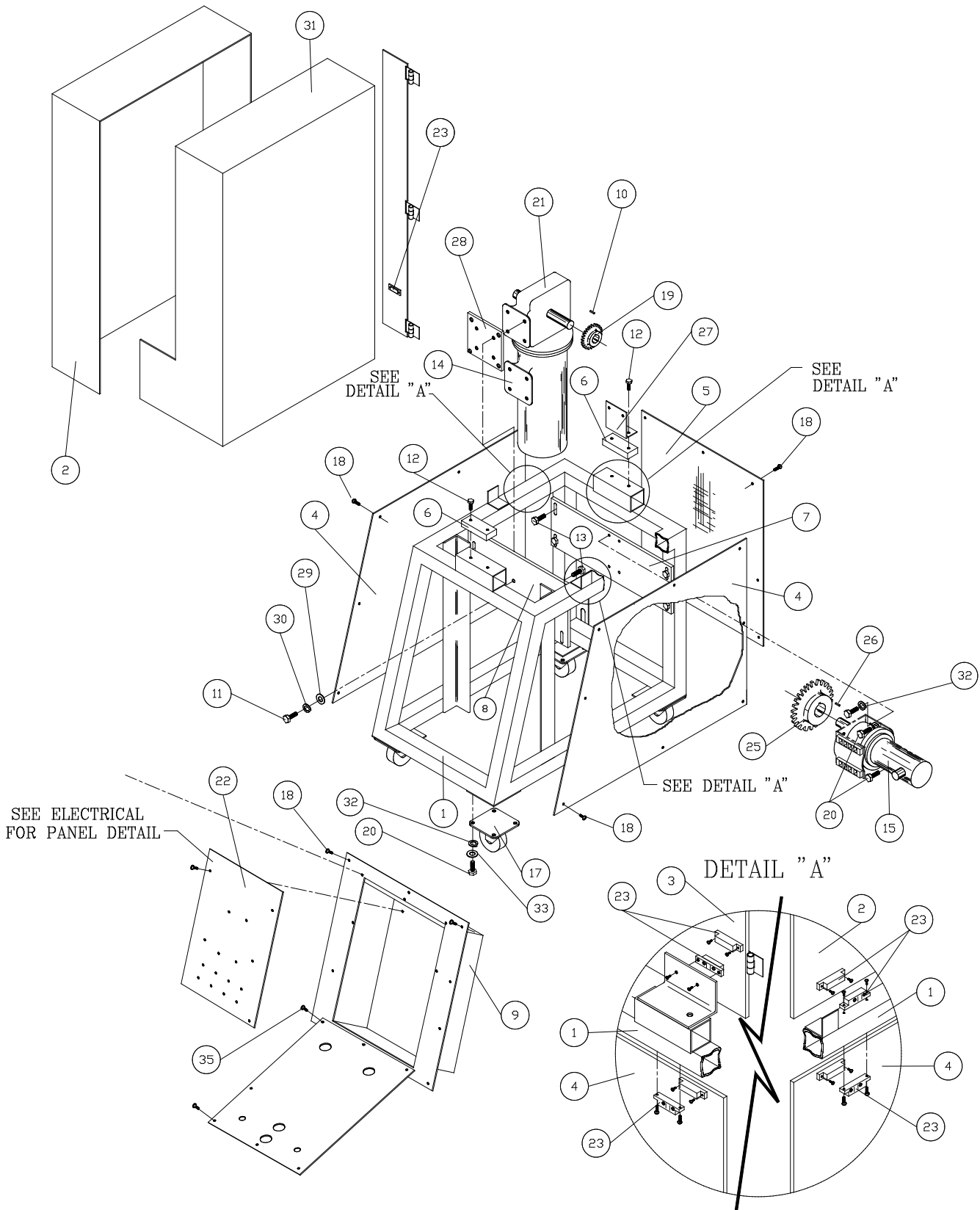

CABINET ASSEMBLY

ITEM	PART NO.	DESCRIPTION	NO. REQ'D
1	K602C	CABINET FRAME	1
2	K609AC	CABINET CASE (LEFT SIDE)	1
4	K605C	CABINET FRAME SIDE PANEL	2
5	K608C	CABINET FRAME BACK PANEL	1
6	K611C	SIDE PANELS SPACER BAR	2
7	K606C	KNIFE/DISCHARGE MOTOR DRIVE PLATE	1
8	K607C	MAIN DRIVE MOTOR MOUNT PLATE	1
9	K603C	ELECTRIC BOX	1
10	F0403KY	SHAFT KEY	1
11	F0606HH	BOLT	4
12	F0506HH	BOLT	4
13	F0504HH	BOLT	12
14	SS259	ELECTRIC MAIN DRIVE MOTOR	1
15	SS257	ELECTRIC KNIFE/DISCHARGE MOTOR	1
17	621CA1	CASTER ROLLER	4
18	F0402TH	SCREW	46
19	K620C	REDUCER SPROCKET	1
20	F0402HH	BOLT	4
21	SS258	REDUCER	1
22	K613C	ELECTRICAL SUB-PANEL	1
23	SS240	MAGNETIC REED SWITCH	6
25	K617C	MAIN DRIVE MOTOR PLATE	1
26	F0303KY	SHAFT KEY	2
27	K619C	MAGNETIC REED SWITCH ANGLE BRACKET	1
28	K502ES-1	ELECTRIC MAIN DRIVE MOTOR PLATE	1
29	F0600FW	FLAT WASHER	8
30	F0600LW	LOCK WASHER	8
31	K609C	CABINET CASE (RIGHT SIDE)	1
32	F0400LW	LOCK WASHER	20
33	F0400FW	FLAT WASHER	16
34	F0606HH	BOLT	4
35	F9902TH	SCREW	4

NOTE:

GUARDS ARE INTERLOCKED, MACHINE
 WILL NOT OPERATE WITHOUT GUARDS IN
 PLACE.

ROLLER ASSEMBLY

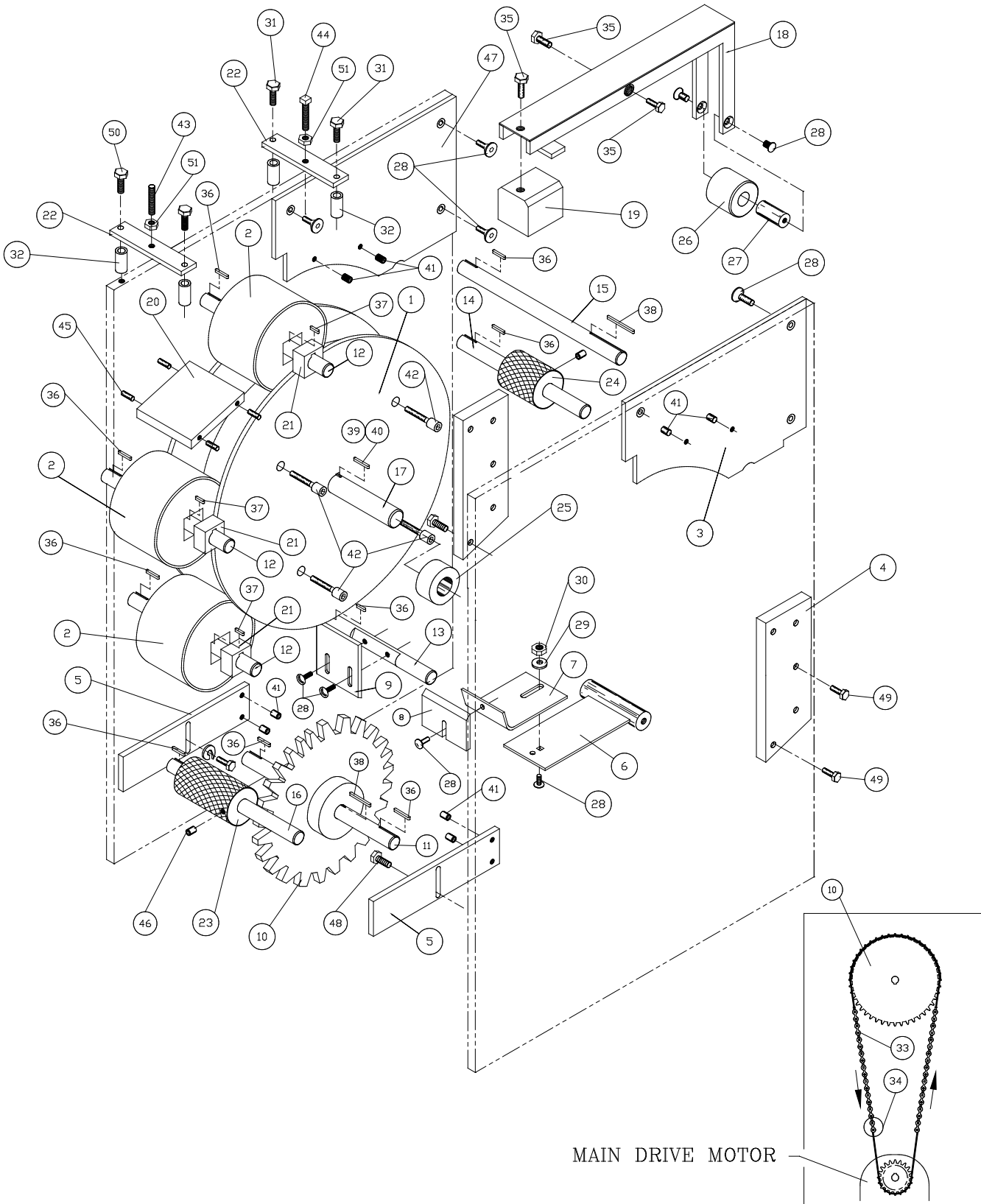

ROLLER ASSEMBLY

ITEM	PART NO.	DESCRIPTION	NO. REQ'D
1	K326RA	DRUM ROLLER	1
2	K314RA	FEED ROLLER	3
3	K310RA-L	DRUM GUIDE LEFT	1
4	K317RA	SUPPORT BRACKET	2
5	K321RA	GUIDE BRACKET (DISCHARGE CONVEYOR)	2
6	K311RA	DRUM SCRAPER BASE	1
7	K312RA	DRUM SCRAPER EXTENSION	1
8	K313RA	DRUM SCRAPER BLADE	1
9	K309RA	KNIFE	1
10	K327RA	SPROCKET	1
11	K305RA	COUNTER SHAFT	1
12	K304RA	SIZING ROLLER SHAFT	3
13	K306RA	KNIFE SHAFT	1
14	K307RA	INFEED CONVEYOR SHAFT	1
15	K303RA	CLUTCH SHAFT	1
16	K307RA	DISCHARGE CONVEYOR SHAFT	1
17	K302RA	DRUM ROLLER SHAFT	1
18	K318RA	ACTUATOR ARM ASSEMBLY	1
19	K338RA	COUNTER WEIGHT	1
20	K328RA	SIZING ROLLER GUARD	1
21	K315RA	DRIVER PLUG	3
22	K320RA	ACTUATOR DOUGH RESTRICTION BAR	2
23	K413CA	DISCHARGE CONVEYOR DRIVE ROLLER	1
24	K412CA	INFEED CONVEYOR DRIVE ROLLER	1
25	K331RA	DRUM SPACER	2
26	K322RA	ACTUATOR ROLLER	1
27	K322RA-1	ACTUATOR ROLLER SHAFT	1
28	F0402FH	BOLT	10
29	F0400FW	FLAT WASHER	1
30	F0400NC	HEX NUT	1
31	F0406HH	BOLT	2
32	642SC	5/16 I.D. X 1/2 LG. SPACER	4
33	K337RA	#40 CHAIN	1
34	K118LS	#40 MASTER LINK	1
35	F0503HH	BOLT	3
36	K332RA	SHAFT KEY	7
37	K333RA	SHAFT KEY	1
38	K334RA	SHAFT KEY	2
39	K335RA	SHAFT KEY	1
40	K336RA	SHAFT KEY	1
41	F0401SS	SET SCREW	4
42	F0609SH	S.H. CAP SCREW	4
43	F0508SHSS	SET SCREW	1
44	F0508SQ	SQ. HD. BOLT	1
45	F0402SS	SET SCREW	4
46	F0501SS	SET SCREW	2
47	K310RA-R	DRUM GUIDE RIGHT	1
48	F0404HH	BOLT	2
49	F0504HH	BOLT	6
50	F0403HH	BOLT	2
51	F0500NC	HEX NUT	2
52	F0400LW	LOCK WASHER	4

LEFT SIDE ASSEMBLY

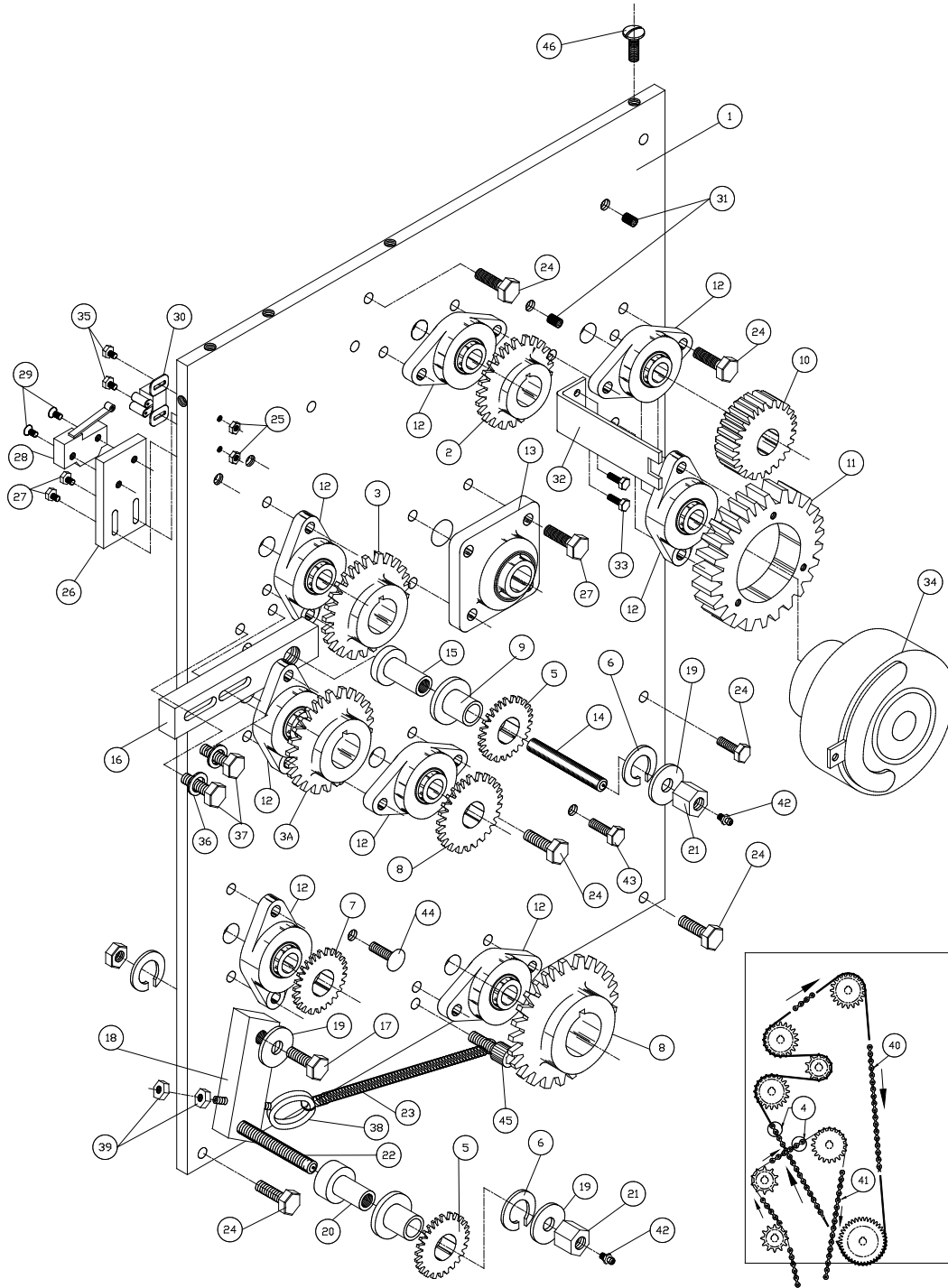

LEFT SIDE ASSEMBLY

ITEM	PART NO.	DESCRIPTION	NO. REQ'D
1	K110LS	LEFT SIDE PANEL	1
2	K112LS	SIZING ROLLER SPROCKET	1
3	K117LS	SIZING ROLLER SPROCKET	1
3A	K111LS	SIZING ROLLER SPROCKET	1
4	K118LS	NO. 40 CHAIN MASTER LINK	2
5	K113LS	TENSION SPROCKET	2
6	F0800LW	LOCK WASHER	2
7	K115LS	DISCHARGE SPROCKET	1
8	K116LS	COUNTER / KNIFE SPROCKETS	2
9	BBT15	BRONZE BUSHING	2
10	K109LS	INFEED CONVEYOR DRIVE GEAR	1
11	K108LS	GEAR (DRIVER CLUTCH)	1
12	VF2S-212	BEARING FLANGE (2) HOLE	8
13	VF4S-216	BEARING FLANGE (4) HOLE	1
14	K104LS-3	THREADED ROD	1
15	K104LS-2	TENSIONSPROCKET SHAFT	1
16	K104LS-1	TENSION ASSEMBLY PLATE	1
17	H0808HH	BOLT	1
18	K203RS-1	TENSION BAR	1
19	F0800FW	FLAT WASAHER	3
20	K203RS-2	TENSION SPROCKET SHAFT	1
21	F0800NC	HEX NUT	2
22	K203RS-3	THREADED ROD (3 1/2" LG)	1
23	K120LS	TENSION SPRING	1
24	F0504HH	BOLT	22
25	F9600NC	HEX NUT	2
26	K107LS	LIMIT SWITCH MOUNT PLATE	1
27	F0604HH	BOLT	4
28	SS281	LIMIT SWITCH	1
29	F9604BH	SCREW	2
30	K122LS	DOOR HINGE CLAMP	1
31	F0401SS	SET SCREW	4
32	K102LS	ANTI-ROTATION BRACKET	1
33	F0402HH	BOLT	2
34	SS238	CLUTCH	1
35	F9703TH	BOLT	2
36	F0500FW	FLAT WASHER	2
37	F0505HH	BOLT	2
38	F0508EB	EYE BOLT	1
39	F0500NC	HEX NUT	2
40	K124LS	NO. 40 CHAIN (DRIVES SIZING ROLLERS)	1
41	K125LS	NO. 40 CHAIN (DRIVES DISCHARGE & KNIFE)	1
42	3038-B	GRAESE FITTING	2
43	F0405HH	SCREW	2
44	F0404CB	BOLT	2
45	F0504SH	BOLT	1
46	F0402TH	SCREW	8

RIGHT SIDE ASSEMBLY

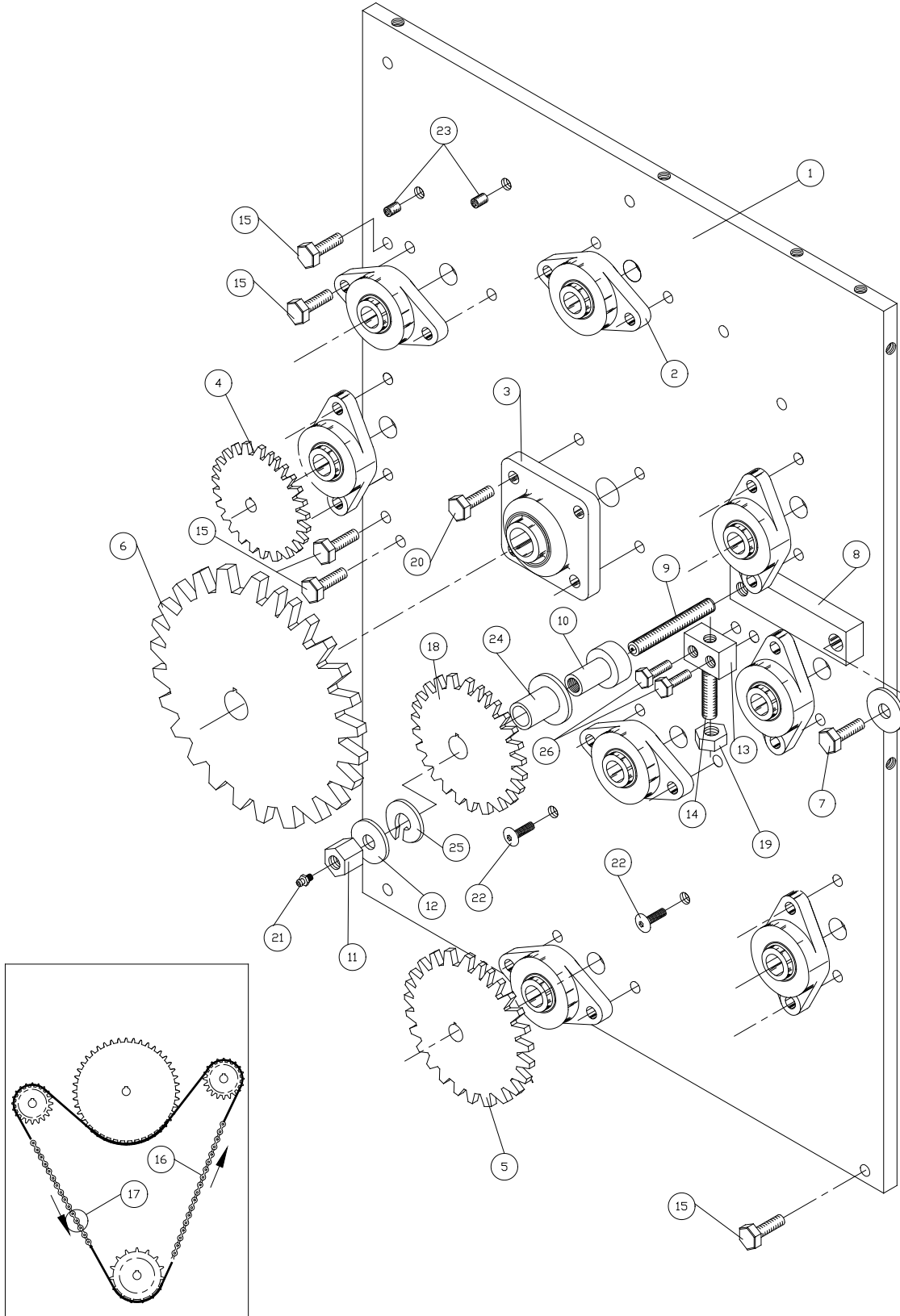

RIGHT SIDE ASSEMBLY

ITEM	PART NO.	DESCRIPTION	NO. REQ'D
1	K210RS	RIGHT SIDE PANEL	1
2	VF2S-212	(2) HOLE BEARING FLANGE	8
3	VF4S-216	(4) HOLE BEARING FLANGE	1
4	K206RS	INFEED CONVEYOR SPROCKET	1
5	K207RS	COUNTER SPROCKET	1
6	K208RS	DRUM ROLLER SPROCKET	1
7	F0805HH	BOLT	1
8	K203RS-1	TENSION BAR	1
9	K203RS-3	1/2 - 13 THREADED ROD	1
10	K203RS-2	SPROCKET TENSION ROD	1
11	F0800NC	1/2-13 HEX NUT	1
12	F0800FW	FLAT WASHER	2
13	K204RS	TENSION ADJUSTMENT BLOCK	1
14	K211RS	SET SCREW	1
15	F0405HH	BOLT W/ LOCK WASHERS	21
16	K209RS	NO. 50 CHAIN	1
17	K212RS	NO. 50 CHAIN MASTER LINK	1
18	K213RS	TENSION SHAFT SPROCKET	1
19	F0504HN	HEX NUT	1
20	F0604HH	BOLT W/ LOCK WASHERS	4
21	3038-B	GREASE FITTING	4
22	F0405BH	SCREW	2
23	F0401SS	SET SCREW	2
24	BBT15	BRONZE BUSHING	1
25	F0800LW	LOCK WASHER	1
26	F0405HH	BOLT W/FLAT & LOCK WASHERS	2
27	F0402TH	SCREW	9

ELECTRICAL SYSTEM

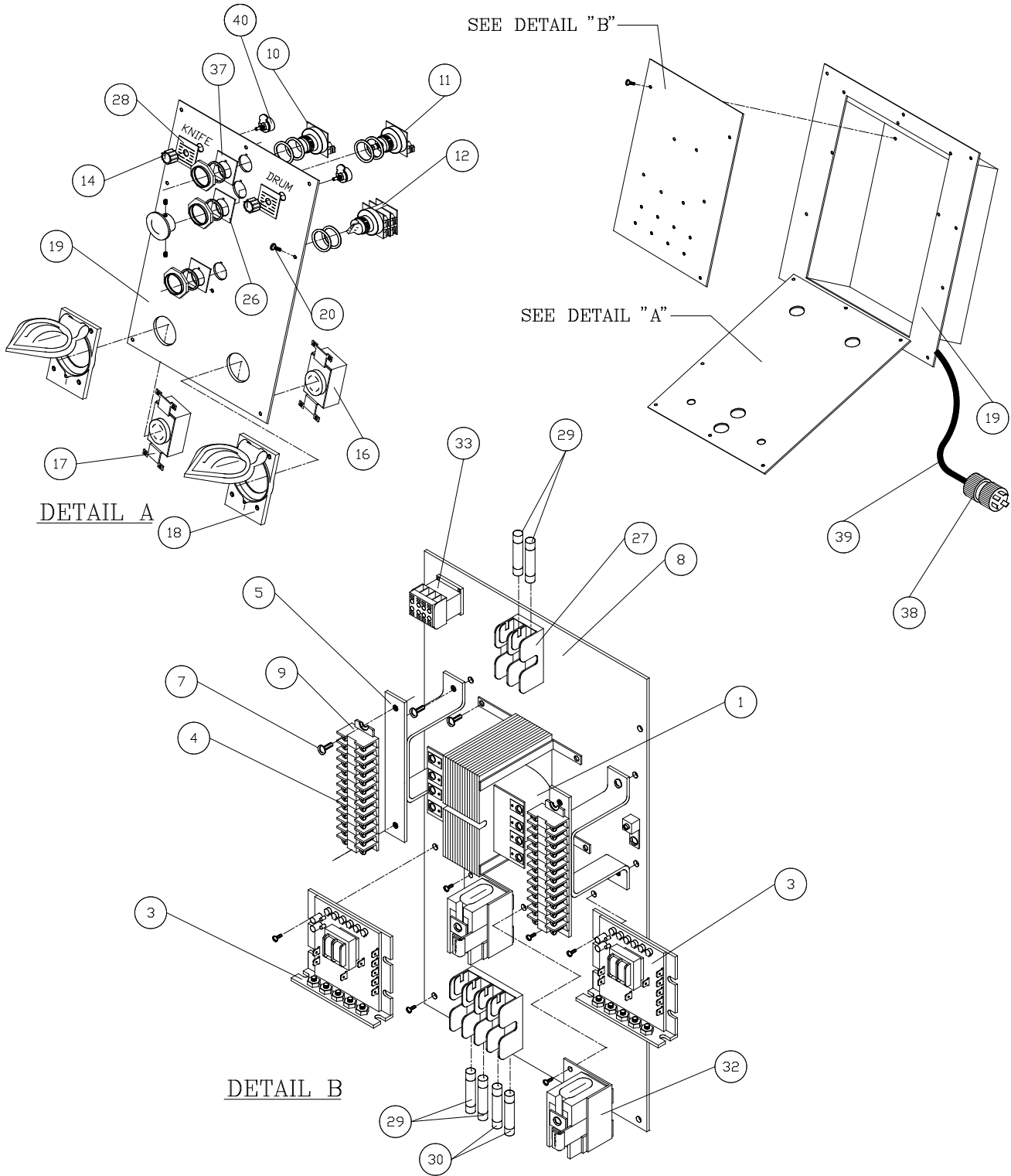

ELECTRICAL SYSTEM

ITEM	PART NO.	DESCRIPTION	NO. REQ'D
1	SS178	TRANSFORMER	1
* * 3	SS193	MOTOR CONTROLLER	2
4	SS144	TERMINAL BLOCK	18
5	K509ES	"U" BRACKET	2
7	F9704TH	#8-32 SLOTTED TRUSS HEAD BOLT	20
8	K613C	ELECTRICAL SUB-PANEL	1
9	SS145	TERMINAL BLOCK END	4
10	SS184	START PUSH BUTTON (BLACK)	1
11	SS185	STOP PUSH BUTTON (RED)	1
* 12	SS186	MANUAL SELECTOR SWITCH	1
13	SS229	BRIDGE RECTIFIER	1
14	SS234	SELECTOR KNOBS	2
* 16	SS230	20A-125/250V RECEPTACLE	1
* 17	SS231	20A-250V3 DIA. RECEPTACLE	1
* 18	SS235	ALUM. WALL PLATE W/ LIFT COVER	1
19	K603C	ELECTRICAL BOX	1
20	F9902TH	SCREW	8
21	SS240	MAGNETIC REED SWITCH	4
22	SS258	REDUCER MOTOR	1
23	SS257	ELECTRIC KNIFE/DISCHARGE MOTOR	1
24	SS238	CLUTCH	1
25	SS281	LIMIT SWITCH	1
26	SS122	STOP BUTTON LEGEND PLATE	1
27	SS142	FUSE BLOCK	3
28	SS233	LEGEND PLATE	2
29	SS135	FUSE (5 AMP.)	4
30	SS136	FUSE (8 AMP.)	2
31	SS283	LIMIT SWITCH COVER	1
32	SS294	OVERLOAD RELAY W/ 1-SS297 & 1-SS298 OVERLOADS	2
33	SS236	CONTROL RELAY	1
34	SS259	MAIN DRIVE MOTOR	1
35	K532ES	BRIDGE RECTIFIER BLOCK	1
36	K533ES	BRIDGE RECTIFIER BLOCK GUARD	1
37	SS121	START BUTTON LEGEND PLATE	1
38	SS159	PLUG	1
39	SS219	1 1/4 CAROLPRENE	15 FT.
40	SS349	SPEED POT	2

* * MOTOR H.P. MUST BE REQUESTED WHEN ORDERING THIS ITEM.
 * OPTIONAL WITH ROTARY KNIFE DIVIDER/FORMER: MODEL RK2100.

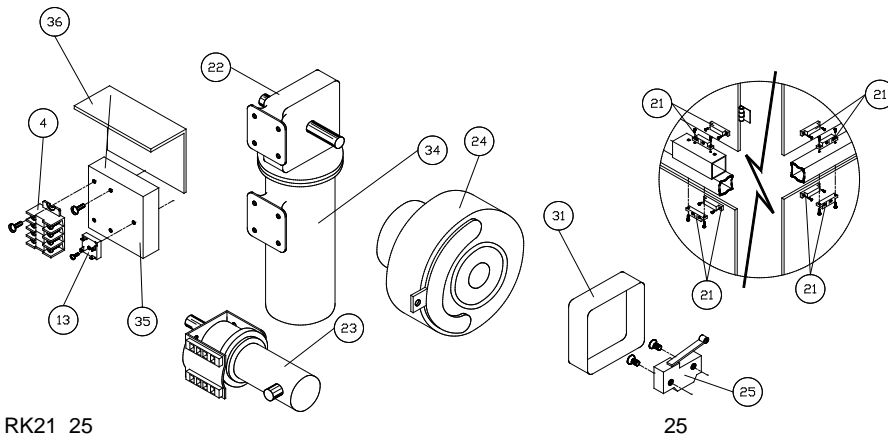

NOTE:

GUARDS ARE INTERLOCKED,
 MACHINE WILL NOT OPERATE
 WITHOUT GUARDS IN PLACE.

ELECTRICAL (SCHEMATIC) RK2001 SINGLE PHASE 230 / 208 VOLTS

CONVEYOR PLUG
 2321

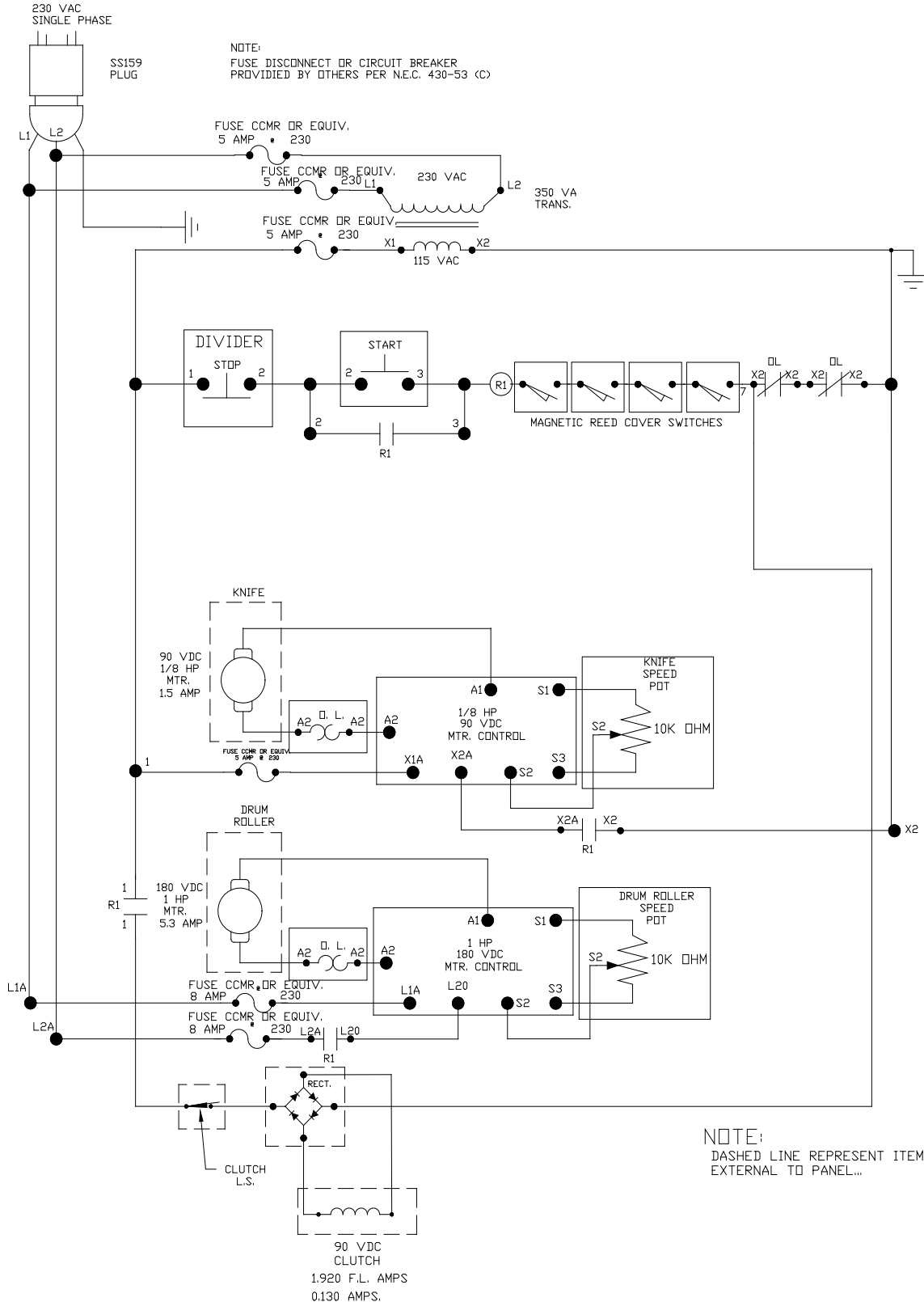

ELECTRICAL (HARDWIRE) RK2001 SINGLE PHASE 230 / 208 VOLTS

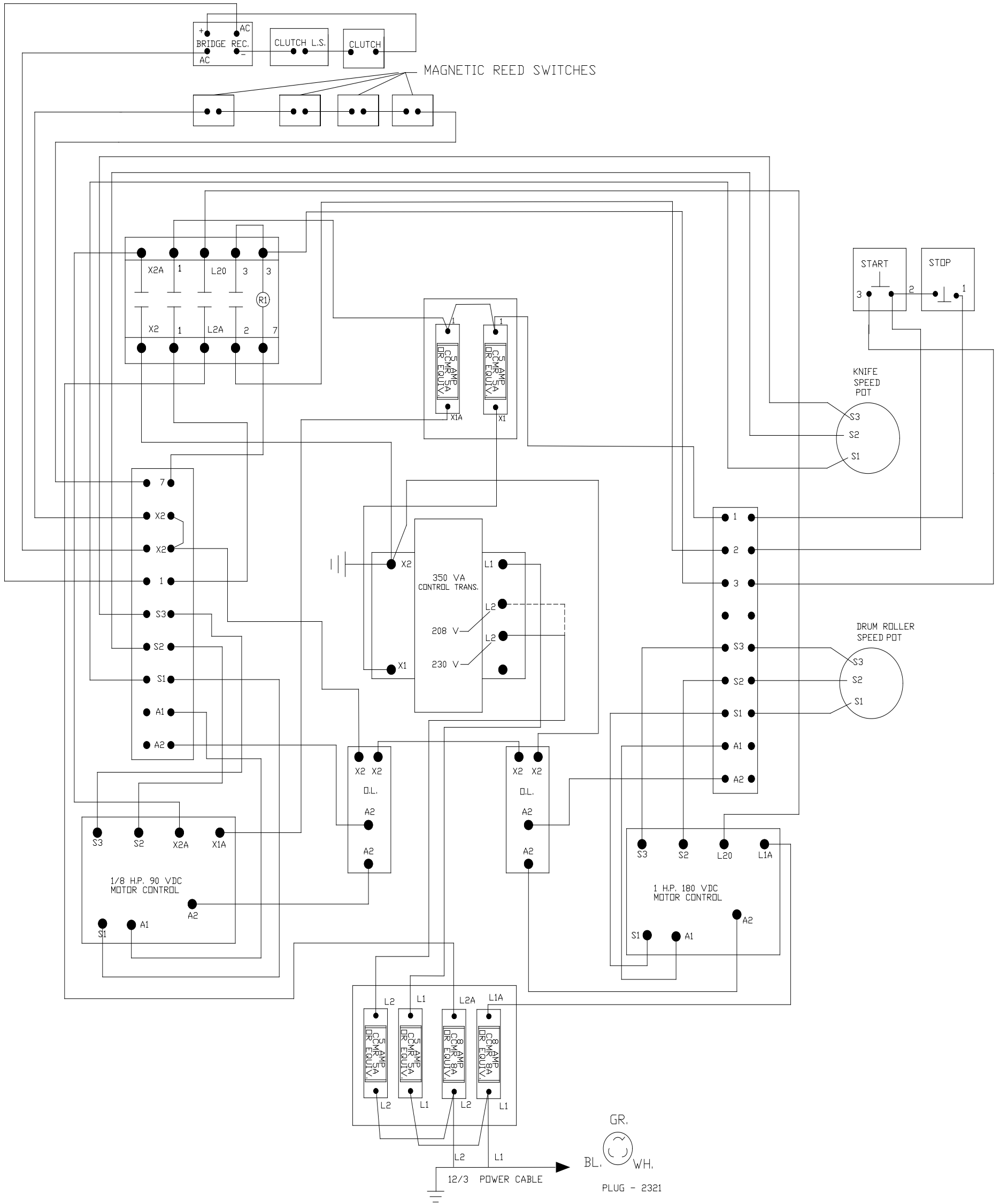

ELECTRICAL (SCHEMATIC) RK 2100 THREE PHASE 230 / 208 VOLTS

NOTE:
 FUSE DISCONNECT OR CIRCUIT BREAKER
 PROVIDED BY OTHERS PER N.E.C. 430-53 (C)

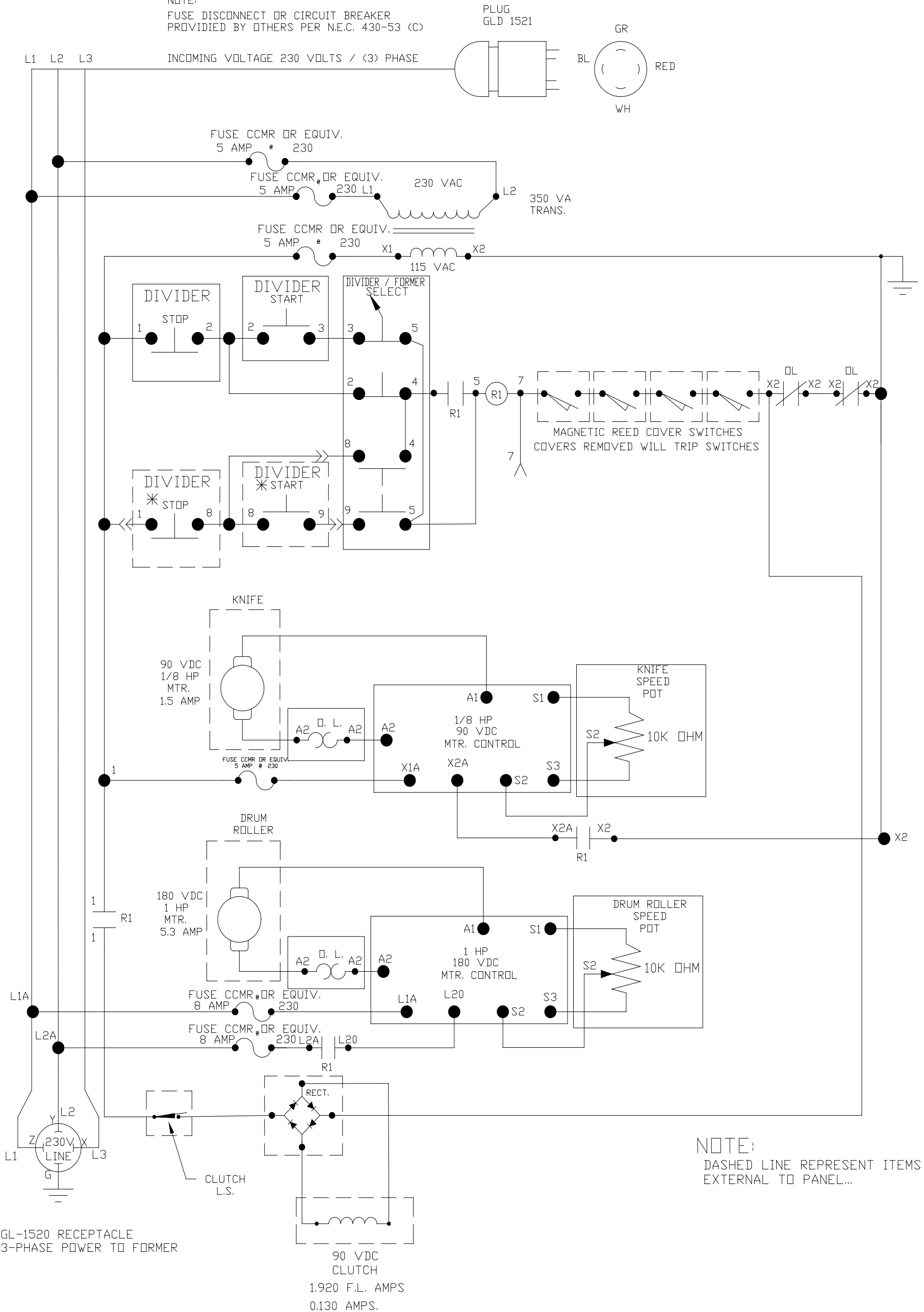

ELECTRICAL(HARDWIRE) RK2100 THREE PHASE 230 / 208 VOLTS

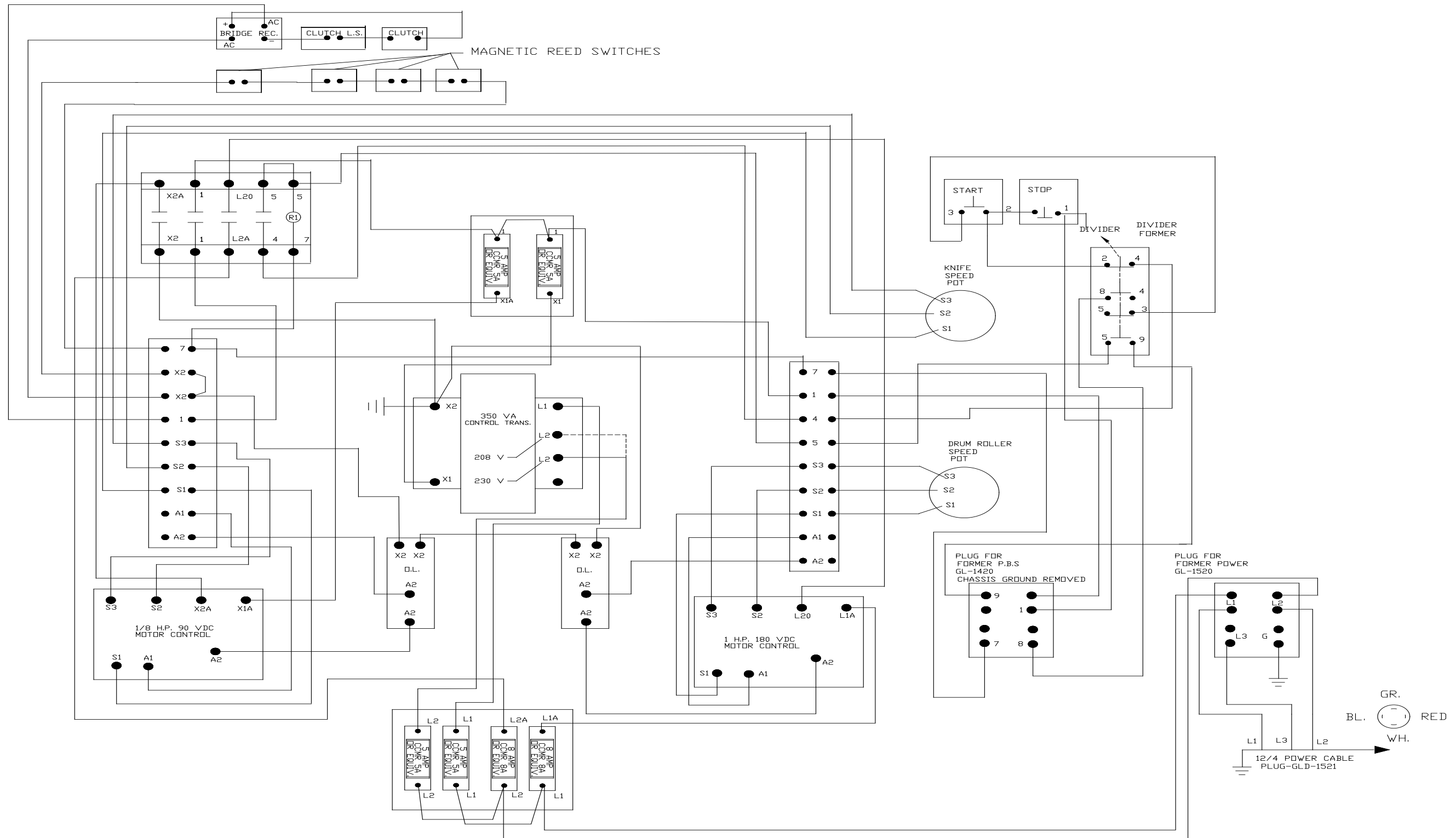

ORDERING REPLACEMENT PARTS

IMPORTANT:

ONLY USE FACTORY SUPPLIED REPLACEMENT PARTS TO MAINTAIN MACHINE SAFETY, PERFORMANCE AND SANITARY CONDITIONS.

USE OF NON-APPROVED PARTS MAY VOID MANUFACTURES WARRANTY.

TO ORDER REPLACEMENT PARTS ALWAYS:

- 1) CHECK THE MACHINE TOP IDENTIFY MISSING, DAMAGED OR NON-FUNCTIONAL PARTS INCLUDING GUARDS, WARNING LABELS AND INSTRUCTIONS.
- 2) COMPARE THE LIST WITH THE PARTS DIAGRAMS SUPPLIED.
- 3) RECORD THE COMPLETE MODEL AND SERIAL NUMBER OF THE UNIT.
- 4) CALL A.M. MANUFACTURING (800) 342-6744 AND PROVIDE ALL INFORMATION NOTED ABOVE TO EXPEDITE ORDER PROCESSING AND HELP REDUCE SHIPPING COST.
- 5) PROVIDE COMPLETE DETAILS FOR (SHIP TO) AND (BILL TO) INFORMATION. TO ASSIST PROMPT DELIVERY, SPECIFY TYPE OF CARRIER PREFERRED IN SHIPMENT.
- 6) MOST MAJOR CREDIT CARDS ACCEPTED.

ASSEMBLY INSTRUCTIONS (FOR JOINING MACHINES)

PART # RK21CONN



CAUTION: FOR SAFE ASSEMBLY, AT LEAST (2) TWO PEOPLE ARE REQUIRED. THE MACHINES ARE HEAVY AND MAY CAUSE STRAIN TO AN INDIVIDUAL.

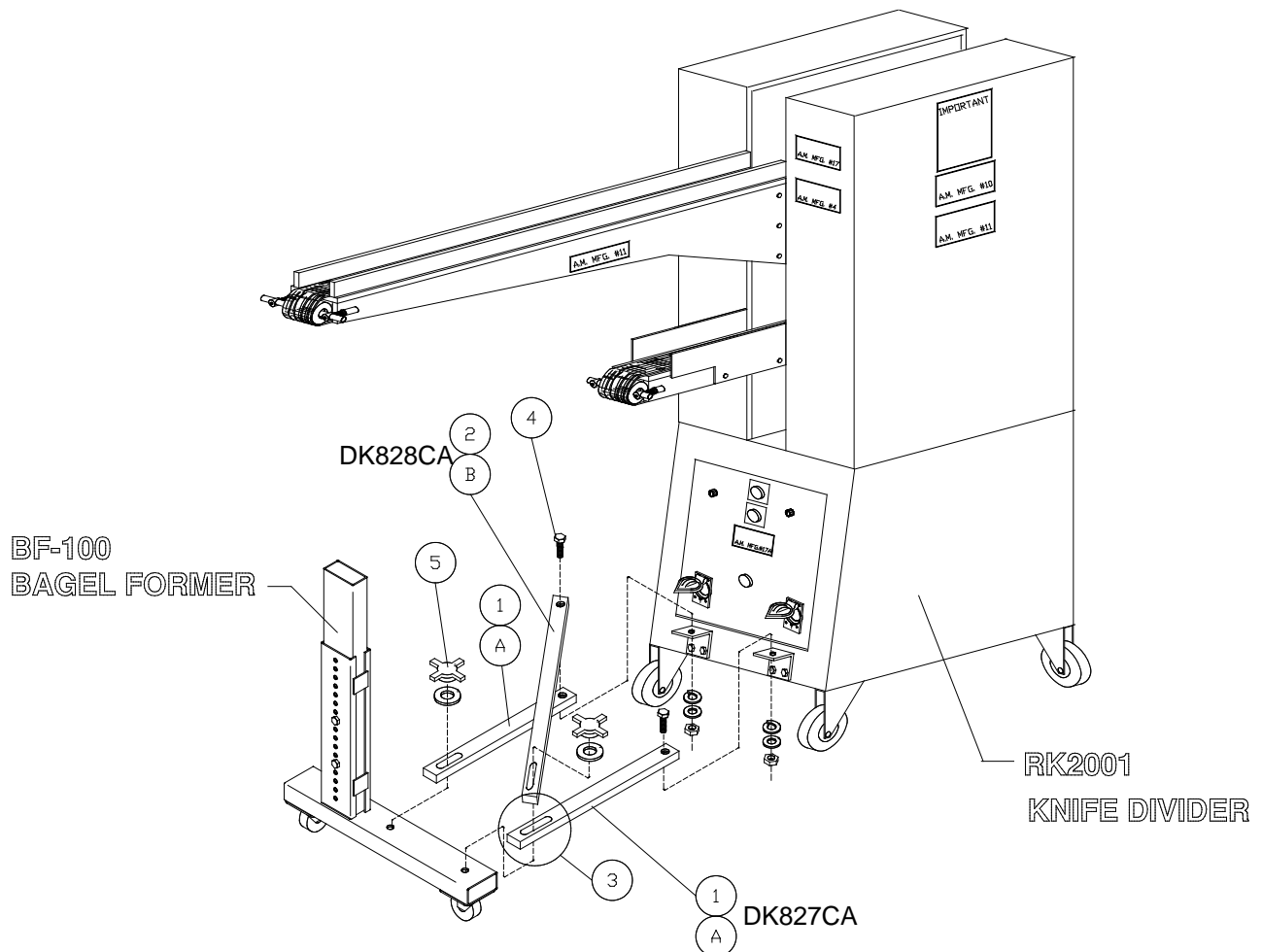

- 1.) THE SHORTER LINKS "A" ARE ATTACHED FROM THE DIVIDER TO THE FORMER SO THAT THEY ARE PARALLEL TO EACH OTHER.
- 2.) THE SINGLE LONG LINK "B" RUNS AT A DIAGONAL FROM THE RIGHT SIDE OF THE DIVIDER (LOOKING TOWARDS THE FORMER) TO THE LEFT SIDE OF THE FORMER LEG AND IS MOUNTED ON TOP OF THE PARALLEL LINKS "A".
- 3.) THE SLOTS IN BOTH "A" & "B" ARE LOCATED AT THE FORMER END.
- 4.) THE 3/8" BOLTS ARE USED TO ATTACH THE LINKS TO THE DIVIDER ATTACHMENT LUGS ARE NOT TO BE TIGHTENED MORE THAN JUST SNUG.
- 5.) FOR ADJUSTMENT PURPOSES THE STAR KNOBS: ARE LOOSENED, THE (2) TWO MACHINES ARE ALIGNED AS NECESSARY AND THE (2) STAR KNOBS ARE RETIGHTENED.