



MANUFACTURING
COMPANY

-SINCE 1961-



R900C Dough Rounder
OPERATIONS & SAFETY MANUAL

Visit us at:

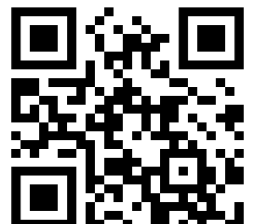

© COPYRIGHT 2025

9200 CALUMET AVE. SUITE NW 07 MUNSTER, IN 46321
(219) 472-7272 | (800) 342-6744 | FAX: (219) 472-7271 | www.ammfg.com

Cautions

THE ENTIRE CONTENTS OF THIS PUBLICATION ARE COPYRIGHTED AND ALL RIGHTS ARE RESERVED. REPRODUCTION IN WHOLE OR IN PART IS PROHIBITED WITHOUT WRITTEN NOTICE PERMISSION OF AM MFG. INC.

⚠ CAUTION:

DO NOT OPERATE, CLEAN, OR SERVICE THIS MACHINE BEFORE YOU READ THIS MANUAL AND ARE FAMILIAR WITH THE SAFETY INSTRUCTIONS IN THIS MANUAL AND THOSE ON THE LABELS ON THE MACHINE. KEEP THIS MANUAL AND OTHER MATERIALS DELIVERED WITH THE MACHINE ACCESSIBLE TO THE OPERATORS FOR EASY REFERENCE DURING USE.

NOTE: PICTURES AND DIAGRAMS MAY BE 3D REPRESENTATIONS AND MAY NOT DIRECTLY REPRESENT YOUR MACHINE.

Owners Responsibility



NOTE:

THE PARTS AND EQUIPMENT DESCRIBED IN THIS MANUAL MAY BE COVERED BY ONE OR MORE U.S. AND FOREIGN PENDING PATENTS.

THE ENTIRE CONTENTS OF THIS PUBLICATION ARE COPYRIGHTED AND ALL RIGHTS ARE RESERVED. REPRODUCTION IN WHOLE OR IN PART IS PROHIBITED WITHOUT WRITTEN NOTICE PERMISSION OF AM MFG. INC

FOLLOW ALL INSTALLATION INSTRUCTIONS.

MAKE SURE INSTALLATION CONFORMS TO ALL APPLICABLE LOCAL, STATE, AND FEDERAL CODES, RULES, AND REGULATIONS SUCH AS STATE AND FEDERAL OSHA REGULATIONS AND ELECTRICAL CODES.

CAREFULLY CHECK THE UNIT FOR CORRECT INITIAL FUNCTION.

READ AND FOLLOW THE SAFETY INSTRUCTIONS. KEEP THEM READILY AVAILABLE FOR MACHINE OPERATORS.

MAKE CERTAIN ALL OPERATORS ARE PROPERLY TRAINED, AND THAT THEY KNOW HOW TO OPERATE THE UNIT AND ARE PROPERLY SUPERVISED SAFELY AND CORRECTLY.

ALLOW UNIT OPERATION ONLY WITH ALL PARTS INCLUDING SAFETY EQUIPMENT, IN PLACE AND OPERATING SAFELY.

CAREFULLY INSPECT THE UNIT ON A REGULAR BASIS AND PERFORM ALL MAINTENANCE AS REQUIRED.

SERVICE AND MAINTAIN THE UNIT ONLY WITH AUTHORIZED OR APPROVED REPLACEMENT PARTS.

KEEP ALL INSTRUCTIONS PERMANENTLY WITH THE UNIT ALONG WITH ALL DECALS AND WARNING LABELS ON THE UNIT CLEAN AND VISIBLE.

Table of Contents

Cautions	1
Owners Responsibility	2
Table of Contents	3
Introduction	4
Specifications	5
Installation Instructions for Location.....	6
Safety Rules.....	7
Safety Signal Words	8
Warning Label Locations	9
Warning Labels.....	10
Operating Instructions.....	11
Start up and Operation Procedures.....	11
General Overview of the R900C.....	12
General Cleaning Instructions	13
Cleaning Disassembly	13
Component Cleaning	13
Post Cleaning Assembly.....	13
General Maintenance	14
Basic Trouble Shooting Guide.....	15
AM Manufacturing Service Department Contact Information.....	15
Parts Catalogue	16
Rounder Assembly Parts Breakdown.....	17
Rounder Assembly Parts List	18
Rounder Base Assembly Parts Breakdown	19
Rounder Base Assembly Parts List	20
Cabinet Assembly Breakdown.....	21
Cabinet Assembly Parts List.....	22
Cabinet Assembly Breakdown.....	23
Cabinet Assembly Parts List.....	24
Schematics Sheet 1.....	25
Schematics Sheet 2.....	26
Schematics Sheet 3.....	27
Ordering replacement parts.....	28

Introduction

READ AND FAMILIARIZE YOURSELF WITH THIS MANUAL BEFORE OPERATING THIS MACHINE.

FOLLOW ALL THE INSTRUCTIONS BEFORE USE.

The R900C dough rounder has been built with the busy baker in mind. Its versatility and simplicity is unmatched in the industry. Production depends on the desired dough ball size and how fast the divided dough pieces are dropped into the funnel. Small pieces can be fed approximately two per seconds, whereas larger dough pieces (up to 2 lbs.) must be fed at a lesser rate.

Getting the feeling of the machine will best determine just what the feed rate should be for any certain dough ball size. No adjustments are necessary when changing the size of your dough piece, it will automatically be rounded into a tight, smooth ball, with no more effort than it takes to drop them into the funnel.

CAUTION:

- ALL OPERATORS MUST BE FULLY TRAINED AND INSTRUCTED IN SAFETY PROCEDURES BEFORE BEGINNING PRODUCTION.

IMPORTANT:

AM MANUFACTURING COMPANY RESERVES THE RIGHT TO MAKE CHANGES IN DESIGN, SPECIFICATIONS OR MANUFACTURING TO IMPROVE THEIR PRODUCTS WITHOUT NOTICE AND WITHOUT OBLIGATION TO CHANGE OR IMPROVE PREVIOUSLY BUILT PRODUCTS, INCLUDING MANUALS AND CATALOGS.

DIAGRAMS AND FIGURES WITHIN THIS MANUAL ARE OFTEN 3D REPRESENTATIONS AND MAY NOT REPRESENT YOUR MACHINE IN IT'S ENTIRETY.

ONLY USE FACTORY SUPPLIED REPLACEMENT PARTS TO MAINTAIN MACHINE SAFETY, PERFORMANCE AND SANITARY CONDITIONS. USE OF NON-APPROVED PARTS MAY VOID MANUFACTURERS WARRANTY.

KNOW YOUR UNIT. COMPARE DIAGRAMS IN THIS MANUAL WITH THE UNIT BEFORE STARTING SERVICE TO OBTAIN MAXIMUM SAFETY AND PERFORMANCE.

WARNING:

THIS MANUAL CONTAINS CRITICAL SAFETY INSTRUCTIONS. READ AND FOLLOW THEM CAREFULLY. FAILURE TO FOLLOW WARNINGS AND INSTRUCTIONS MAY LEAD TO SERIOUS PERSONAL INJURY. THE OWNER IS RESPONSIBLE FOR MAINTAINING THE UNIT, ITS INSTRUCTIONS, AND DECALS FOR OPERATION REFERENCE. FOR ADDITIONAL COPIES CONTACT AM MANUFACTURING: (800) 342-6744

Specifications

All dimensions below are approximate.

A	CABINET WIDTH	24-1/8"
B	HEIGHT TO CABINET TOP	36-1/4"
C	OVERALL HEIGHT	43"
D	LENGTH WITH CONVEYOR	42-5/8"

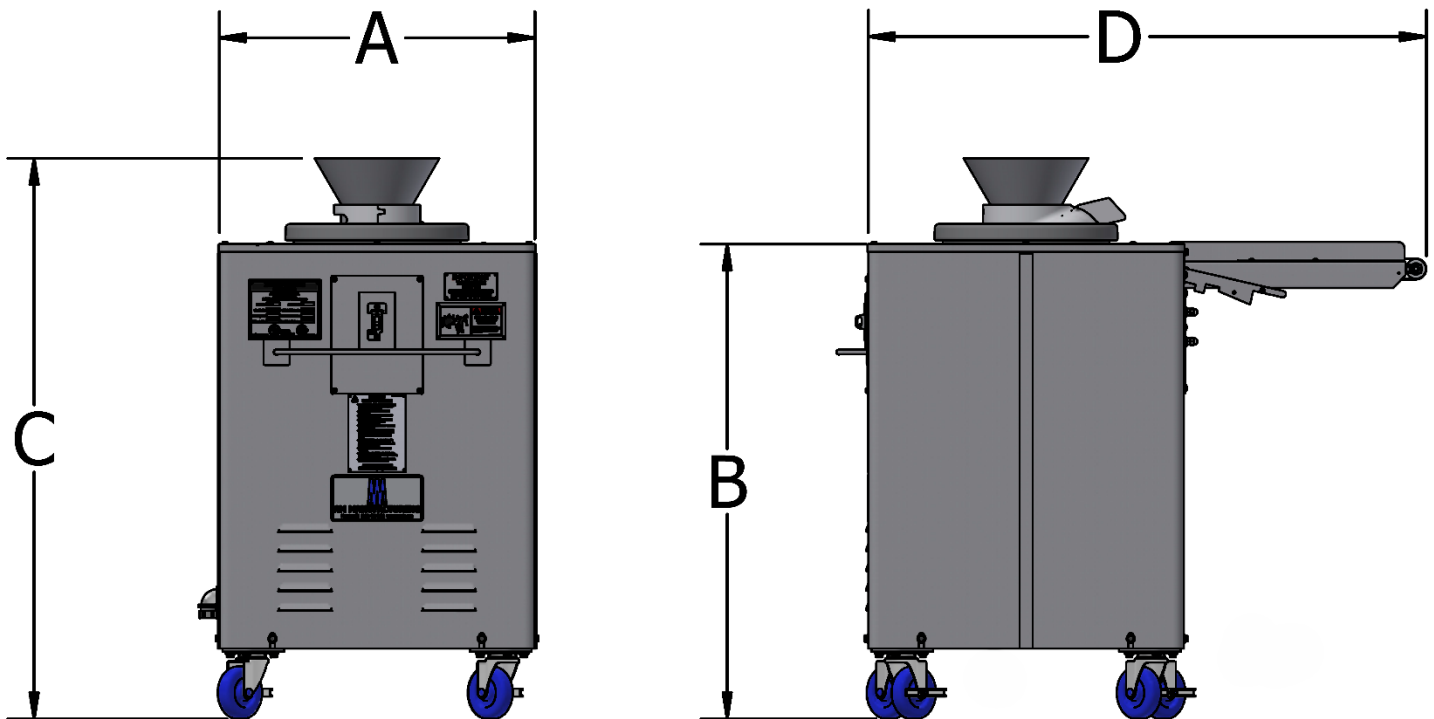

Figure 1: Specifications

Installation Instructions for Location

Select location carefully. The area should provide the operator with enough space to use the equipment in a safe manner. The floor area selected should be a flat surface, easy to clean, and should be free of oil, grease, etc.

CAUTION:

PROPER UNIT INSTALLATION IS NECESSARY FOR SAFE AND EFFICIENT OPERATION. PROPER INSTALLATION ALSO HELPS PROTECT THE UNIT FROM DAMAGE AND MAKES SERVICE EASIER. ALL MOVING PARTS, WITH EXCEPTION OF NECESSARY CONVEYING SURFACES, SHOULD BE COVERED AND GUARDED WHEN THE MACHINE IS IN OPERATION.

1. Open the crate and remove all packing materials, packing slips, documents, and other loose materials. Make certain to remove all manuals and schematics from the crate.
2. Move the unit to the desired location.
3. Lock the bottom two locking casters using their levers.

Safety Rules



- READ AND FOLLOW THESE SAFETY RULES. THEY ARE FOR YOUR PROTECTION AND THE PROTECTION OF THOSE WORKING WITH YOU.
- DO NOT OPERATE THIS MACHINE BEFORE YOU HAVE READ AND UNDERSTOOD THE OPERATIONS AND SAFETY MANUAL.
- FOLLOW ALL INSTRUCTIONS DURING USE OF THIS MACHINE.
- LEAVE ALL GUARDS IN PLACE. INSTALL ALL GUARDS IF THEY WERE REMOVED FOR CLEANING, MAINTENANCE, REPAIR OR OTHER REASONS.
- NEVER OPERATE THE MACHINE IF YOU HAVE NOT BEEN TRAINED TO OPERATE THE MACHINE PROPERLY.
- NEVER OPERATE THE MACHINE IF YOU ARE TIRED, ILL, ON MEDICATION, OR UNDER THE INFLUENCE OF ALCOHOL OR DRUGS.
- WEAR TIGHT-FITTING CLOTHES. MAKE SURE THAT LONG HAIR, JEWELRY, OR LOOSE PERSONAL ITEMS ARE SECURED SO THEY CANNOT GET CAUGHT IN THE MACHINE. THIS CAN LEAD TO SERIOUS INJURIES.
- MAKE SURE YOU CAN EASILY REACH ALL CONTROLS. IF NOT, A STABLE AND SAFE ELEVATED PLATFORM OR OTHER WORK-AID MUST BE PROVIDED.
- ALWAYS DISCONNECT THE MAIN ELECTRICAL POWER SOURCE AND TURN THE MACHINE SWITCH TO THE OFF POSITION BEFORE CLEANING, IF MAINTENANCE OR SERVICE IS PERFORMED, OR IF THE MACHINE IS OUT OF SERVICE.
- NEVER LEAVE THIS MACHINE RUNNING UNATTENDED.

IMPORTANT:

**IF YOU HAVE ANY QUESTIONS ABOUT THESE SAFETY RULES, SEE YOUR SUPERVISOR OR
CALL AM MANUFACTURING CO. TOLL FREE: (800) 342-6744**

Safety Signal Words

THIS MACHINE IS DESIGNED TO PROVIDE SAFE OPERATION IF NORMAL OPERATING PROCEDURES AND SAFETY MESSAGES LOCATED ON THE MACHINE AND IN THIS MANUAL ARE FOLLOWED.



THIS IS A SAFETY ALERT SYMBOL. YOU WILL FIND IT ON VARIOUS SAFETY LABELS ON THE MACHINE AND IT WILL ALSO APPEAR IN THIS MANUAL WHEREVER SAFETY MESSAGES ARE GIVEN.

GET FAMILIAR WITH SIGNAL WORDS:

- **CAUTION:**
 - INDICATES A POTENTIALLY HAZARDOUS SITUATION WHICH, IF NOT AVOIDED, MAY RESULT IN MINOR OR MODERATE INJURY. IT MAY ALSO BE USED TO ALERT AGAINST UNSAFE PRACTICES.
- **WARNING:**
 - INDICATES A POTENTIALLY HAZARDOUS SITUATION WHICH, IF NOT AVOIDED, COULD RESULT IN DEATH OR SERIOUS INJURY.
- **DANGER:**
 - INDICATES AN IMMINENTLY HAZARDOUS SITUATION WHICH, IF NOT AVOIDED, WILL RESULT IN DEATH OR SERIOUS INJURY. THIS SIGNAL WORD IS TO BE LIMITED TO THE MOST EXTREME SITUATIONS.
- **NOTE:**
 - A NOTE PROVIDES KEY INFORMATION TO MAKE PROCEDURES EASIER AND CLEARER.

Warning Label Locations

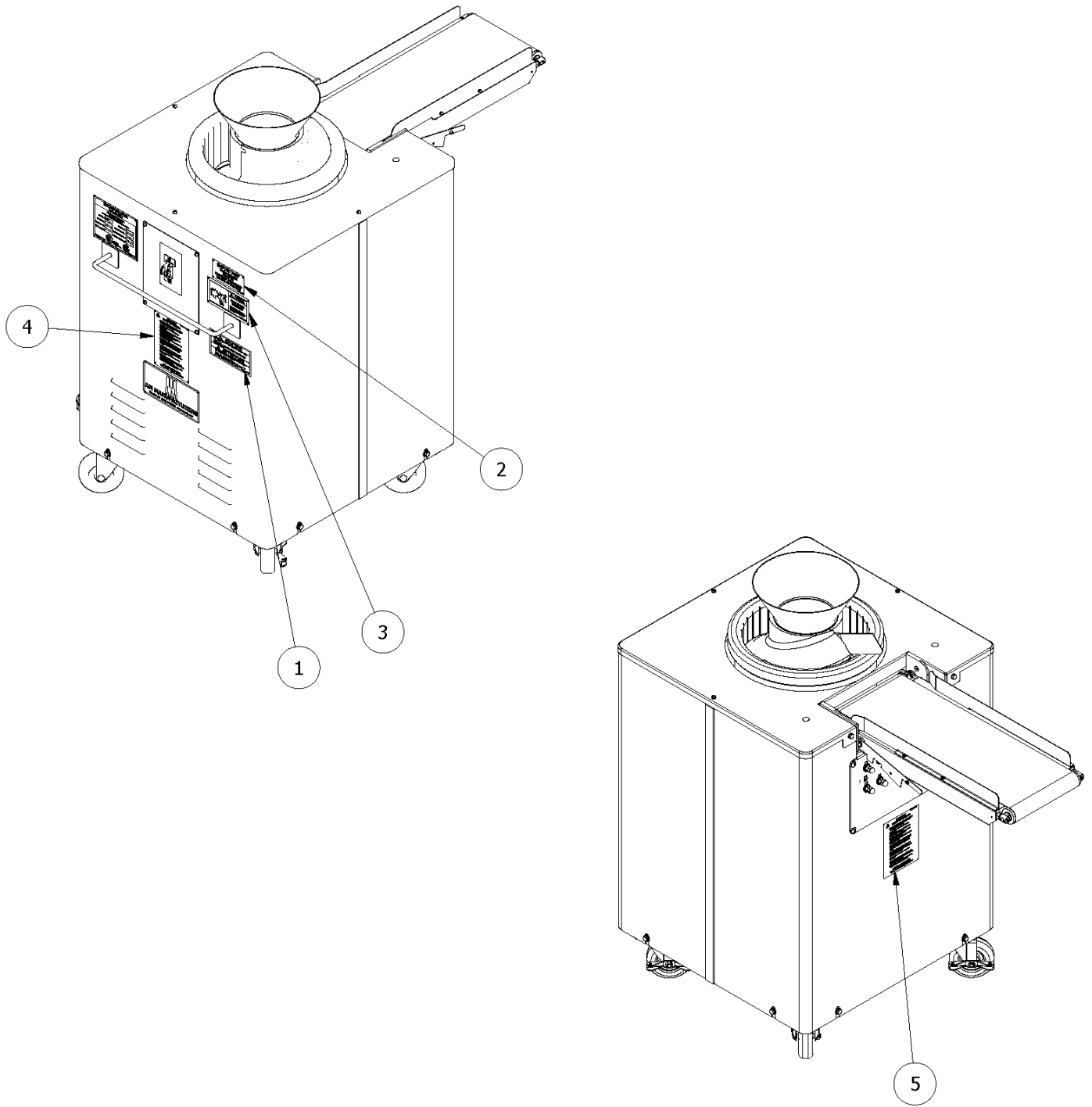



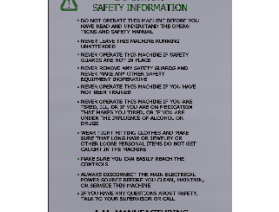



Figure 2: Warning Label Locations

Warning Labels

ITEM#	IMAGE	PART #	DESCRIPTION	LOCATION
1		AMTAG160SF	ROUNDER SCREW CAUTION STICKER	FRONT OF THE CABINET, MIDDLE RIGHT
2		TAG5M	METAL, GROUNDED WARNING LABEL	FRONT OF THE CABINET, TOP RIGHT
3		TAG0AM	METAL, VOLTAGE WARNING LABEL	FRONT OF THE CABINET, TOP RIGHT
4		TAG21M	METAL, SAFETY INFORMATION LABEL	FRONT OF THE CABINET, CENTER
5		TAG21S	STICKER, SAFETY INFORMATION LABEL	BACK OF THE CABINET

Operating Instructions

⚠ WARNING:

UNIT MUST BE PROPERLY OPERATED AND MAINTAINED TO PREVENT MACHINE DAMAGE OR PERSONAL INJURY. REVIEW INSTRUCTIONS WITH ALL EMPLOYEES BEFORE USE.

IMPORTANT:

BEFORE BEGINNING START-UP, READ ALL THE INSTRUCTIONS AND FAMILIARIZE YOURSELF WITH THE LOCATIONS OF ALL CONTROLS. KNOW HOW TO SHUT DOWN THE UNIT IMMEDIATELY IN CASE OF TROUBLE. MAKE CERTAIN ALL PERSONNEL NOT INVOLVED IN THE START-UP ARE SAFELY AWAY FROM THE MACHINE BEFORE ANY SYSTEMS ARE STARTED.

Start up and Operation Procedures

1. Ensure the machine and its components are clear of packing material, packing slips, documents, and other obstructions.
2. Position the rounder in the desired location and lock the two locking casters with their levers.
3. Plug the power cord into the proper outlet.
4. Flip the switch to turn the machine on.
5. The rounder drum should now be turning in a counterclockwise rotation.
6. Drop dough pieces (from 1 oz to 32 oz) into the funnel. The dough will automatically be rounded and then deposited back to the top onto the conveyor.

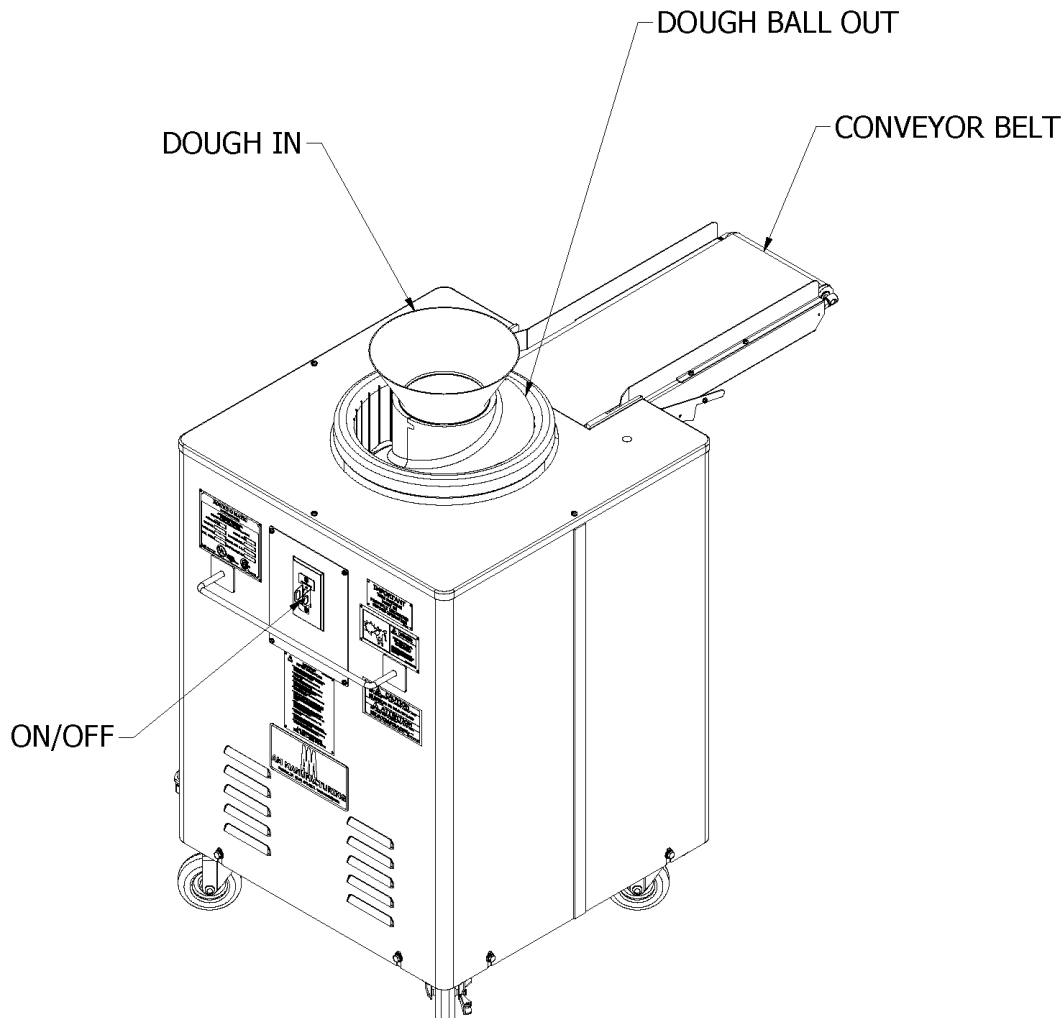

Figure 3: Operations Overview

General Overview of the R900C

The R900C machine has various components that are important to familiarize yourself with to effectively operate, maintain, and clean your machine.

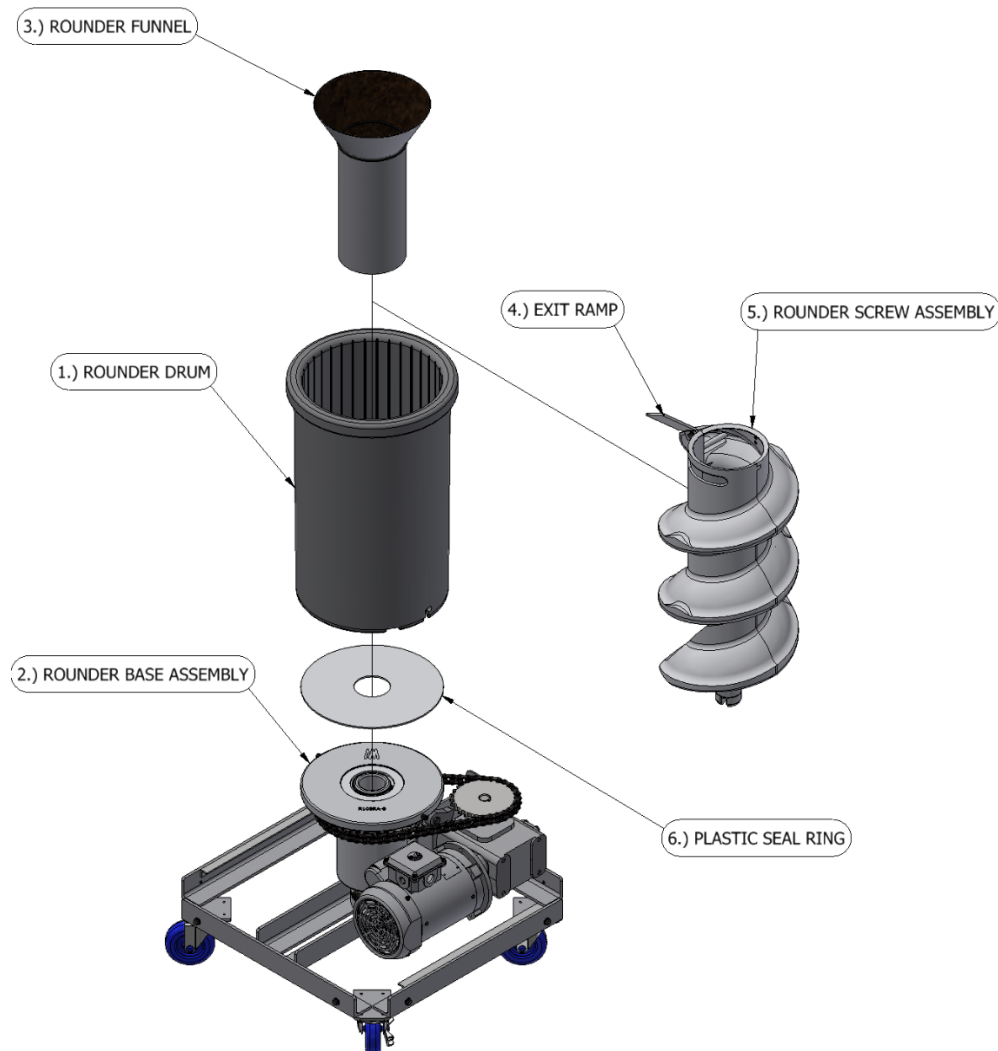

Figure 4: Overview

1. The Plastic Rounder Drum (Figure 4, Item 1) is the large gray drum that rotates counterclockwise while the machine is in operation. This drum is vital in providing the motion to round the dough ball.
2. The Rounder Base Assembly (Figure 4, Item 2) is the rotating assembly driven by the motor. The drum and the Plastic Seal Ring (Figure 4, Item 6) sit on top of the rounder base where the pins on the rounder base insert into the hook cutouts on the bottom of the Rounder Drum. The drum locks into place by turning it in a clockwise motion.
3. The Rounder Funnel (Figure 4, Item 3), which sits atop the Rounder Screw and Rounder Drum, allows the dough ball to drop easily to the bottom of the Rounder Screw (Item 5).
4. The exit ramp (Figure 4, Item 4), which bolts to the top of the Rounder Screw Assembly, assists with guiding the dough ball out of the top of the Rounder Screw.
5. The Rounder Screw Assembly (Figure 4, Item 5) is the screw or auger looking component which provides the path for the dough ball to travel back up. There is an opening at the top where the funnel sits, allowing the dough ball to drop to the bottom. It is then carried back up the outer surfaces to the top by the movement of the Rounder Drum. This movement allows for the rounding of the dough ball.
6. The Plastic Seal Ring (Item 6) is a plastic disc that sits between the Rounder Drum, Screw, and Rounder base Assembly.

General Cleaning Instructions

⚠ WARNING: Before attempting to clean the R900C, make certain that the machine has been properly powered down and the plug has been removed from the power source. Failure to do so could result in serious injury.

All AM Manufacturing machines are tested with dough during the quality audit procedure. Although the machine has been cleaned, some evidence of dough may be detected, this is normal.

All parts in contact with dough should be washed thoroughly after operation with a mild soap and water solution. Disassembly of this machine for cleaning is outlined and illustrated for your convenience.

Cleaning the AM Manufacturing R900C is essential to ensure sanitary conditions and proper machine function. Regular cleaning will extend the life of various components within the machine.

Cleaning Disassembly

1. Shut off all electrical power and unplug the power cord.
2. Remove the funnel.
3. Remove the rounder screw by lifting straight up and out of the machine.
4. Remove the rounder drum by twisting counterclockwise and lifting straight up.
5. Remove the plastic seal ring, which sometimes may stick to the bottom of the rounder drum.

NOTE: If unable to remove the rounder screw, never put hands or arms into the screw.

- Add a small amount of warm water to soften the dough at the bottom, then turn off the rounder.
- The rounder screw should be able to lift out.
 - Improper cleaning or lack of cleaning will cause the rounder screw and base to seize within the machine over time. This can cause it to be extremely difficult to perform maintenance or clean the machine in the future.

Component Cleaning

1. Wash the rounder drum thoroughly with a mild soap and water solution.
2. Wash the rounder funnel.
3. Remove excess dough from and wipe down the rounder base.
4. Wash the rounder screw.
5. Wash the Plastic Seal Ring.
6. Wipe down the conveyor belt.

Post Cleaning Assembly

1. Ensure the electrical power is shut off and unplugged.
2. Place the plastic seal ring onto the top surface of the rounder base.
3. Place the drum back in the machine with the pins lining up to the notches.
4. Place the rounder screw assembly so that the slotted part of the post on the bottom of the screw sits on the pin located within the rounder base.
5. Insert the funnel into the top of the rounder screw.

NOTE: DO NOT DROP ANY OF THE COMPONENTS INTO THE MACHINE. DOING SO MAY CAUSE PREMATURE WEAR AND DAMAGE.

General Maintenance

Read and follow the maintenance instructions below to keep the unit in good operating condition. Regular inspections and maintenance are essential to help prevent accidents and injuries.

⚠ WARNING: Before attempting maintenance on the R900C, make certain that the machine has been properly powered down and the plug has been removed from the power source. Failure to do so could result in injury.

- The R900C has a single drive chain. This chain must be greased regularly with a bearing grease to prolong the life of the sprockets as well as the chain.
- When greasing the chain, inspect and grease the sprocket and chain by the conveyor motor as needed.
- Chain tension should be checked every 60 days.
- Inspect fasteners and ensure they are tightened securely.

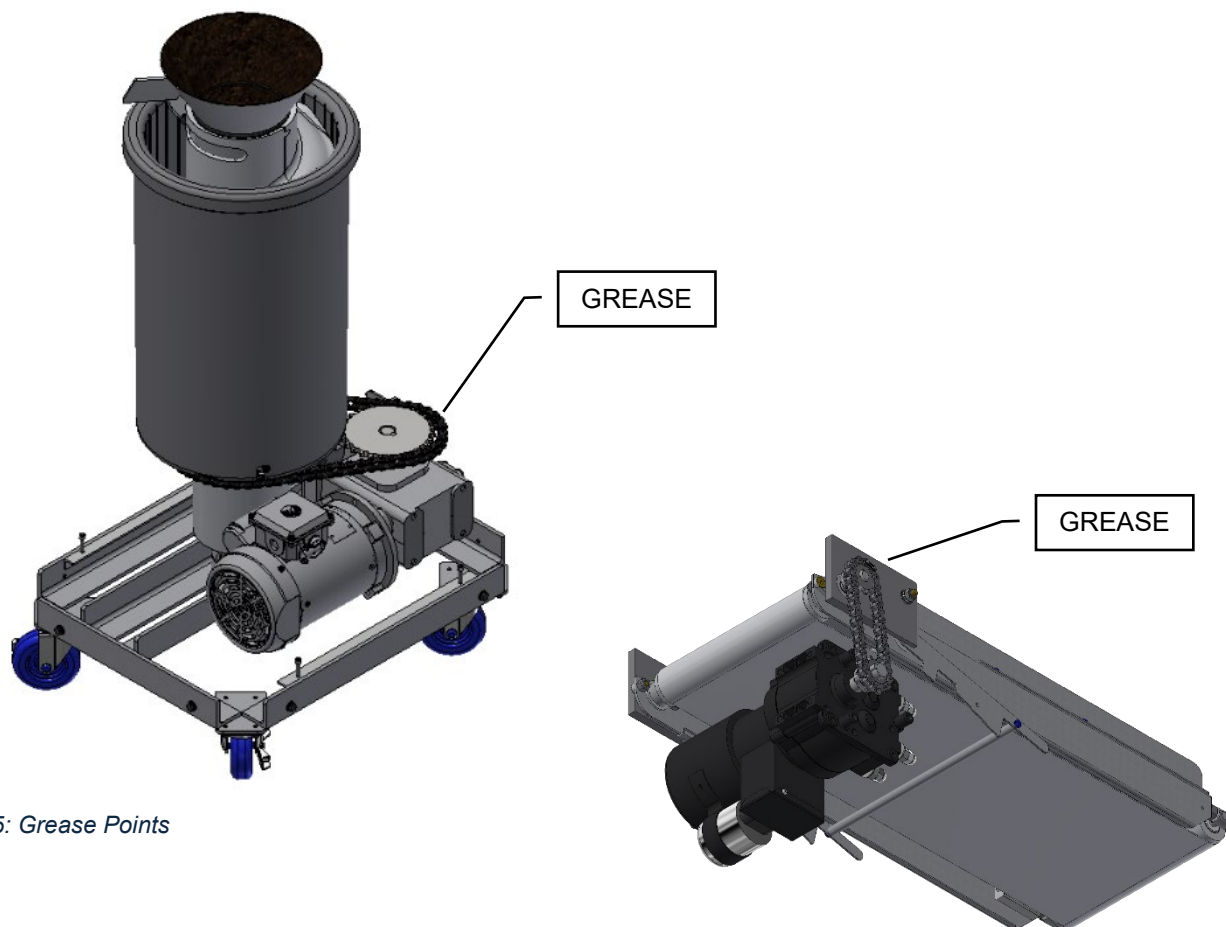

Figure 5: Grease Points

Basic Trouble Shooting Guide

Issue	Probable Cause	Solution
Machine not starting	Power off or faulty push button or contact blocks	Check push button, contact blocks, plugs, and power source. Check the fuse, the overload in the electrical panel, and reset the overload on the motor.
Noise from bottom of the machine	Bearing wear, motor/gearbox issues	Remove the chain and run the machine. If noise persists, inspect the motor and gearbox. If noise stops, inspect the bearings within the rounder base and replace if necessary.
Uneven drum wear	Bearing wear	Inspect the bearings and replace them if necessary.
Rounder Screw Assembly Stuck	Lack of cleaning causing dough to harden and glue the post of the screw into the rounder base.	If freshly stuck, add a small amount of water to the area where the screw inserts into the base. If this does not loosen it, call AM Manufacturing at the number provided below.
Rounder Base Assembly Stuck	Lack of cleaning causing dough to harden and glue the spindle of the rounder base into the frame.	Call AM Manufacturing at the number provided below.
Rounder Drum Notches Broken	Dropping the rounder drum into the machine or not locking the drum in place prior to operation.	Replace rounder drum.
Belt Tracking to One Side	Improper adjustment of tension, worn bearings	Adjust the nuts on the tensioning screws until belt is tracking straight without overtightening the belt.
Belt Wearing Prematurely	Improper tension, overtightening, worn bearings causing the belt to track wrong.	Replace belt, check bearings and shafts, properly adjust tension.
Conveyor Bearing Noise or Wear	Overtightening	Replace bearings and shafts.

AM Manufacturing Service Department Contact Information

Monday through Friday, 7AM to 3:30PM (CST)

Phone: [219-472-6417](tel:219-472-6417)

Monday thru Friday, 3:30PM to 7AM (CST)

and Saturday or Sunday

Phone: [708-328-3400](tel:708-328-3400)

support@ammfg.com

Parts Catalogue



Rounder Assembly Parts Breakdown

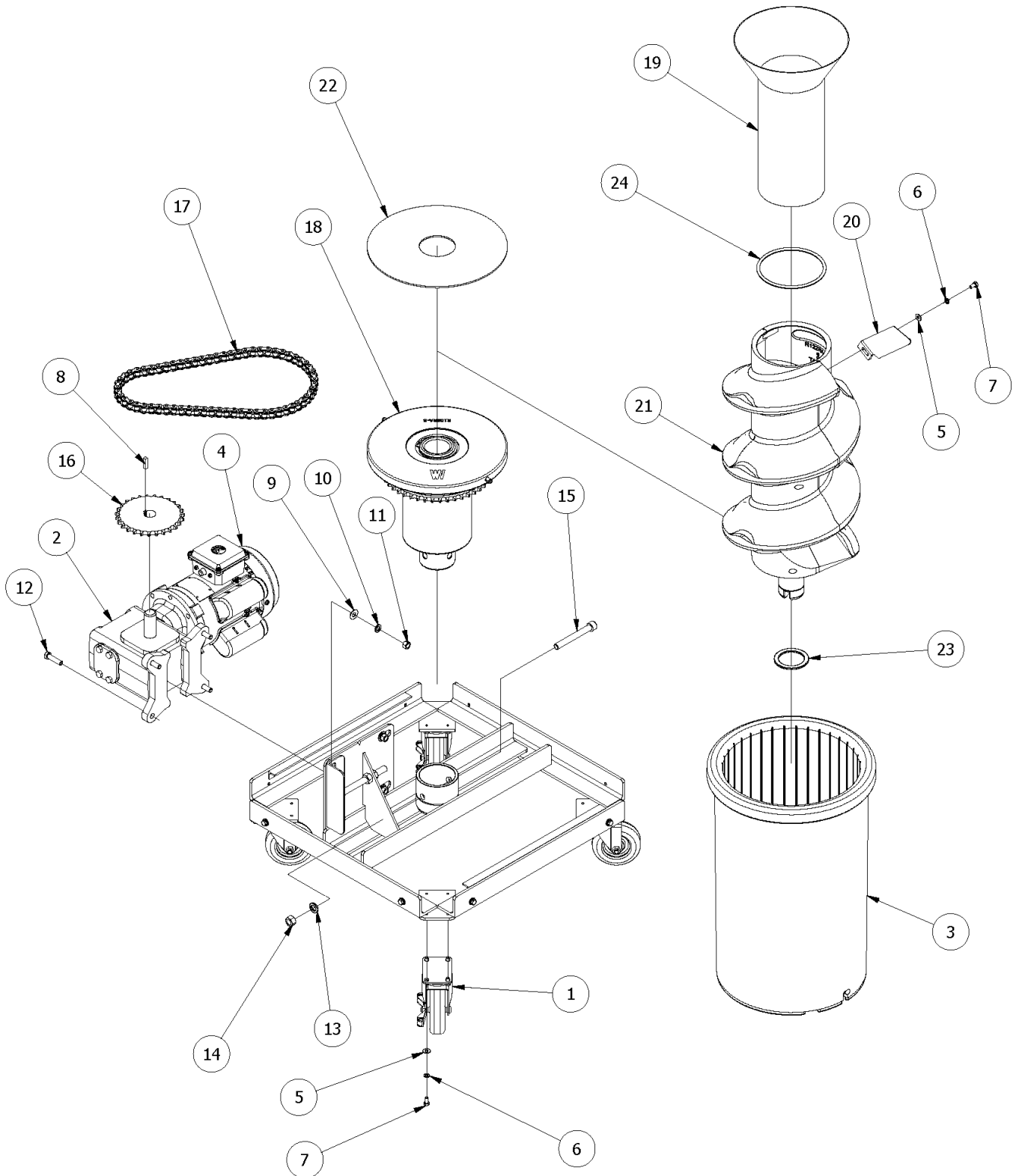

Rounder Assembly Parts List

ITEM	PART NO	DESCRIPTION	QTY
1	621CA1	CASTER, LOCKING 4" DIA	2
2	12081	GEARBOX, 15:1, LEFT HAND (SIZE 21)	1
3	19900	PLASTIC ROUNDER DRUM	1
4	33527	MOTOR- TECH.TOP	1
5	F0400FW	FLAT WASHER, 1/4"	25
6	F0400LW	LOCK WASHER, 1/4"	25
7	F0402HHCS	HEX HEAD CAP SCREW, 1/4-20X1/2" LG.	25
8	F0404KY	1/4" KEY X 1" LONG, S.S.	1
9	F0600FW	FLAT WASHER 3/8"	13
10	F0600LW	LOCK WASHER 3/8"	9
11	F0600NC	3/8-16 HEX NUT	9
12	F0606HHCS	HEX HEAD CAP SCREW 3/8-16 X 1-1/2"	9
13	F0800LW	LOCK WASHER 1/2"	1
14	F0800NC	NUT COURSE, 1/2-13	1
15	F0816SH	1/2-13 SOCKET HEAD BOLT 4" LONG	1
16	R103RA	SPROCKET, 50B27 X 1" BORE W/SET SCR	1
17	R105RA	DRV CHN#50, 31 LINKS W/MASTER LINK	1
18	R108RA	ROUNDER BASE ASSEMBLY	1
19	R116RA	ROUNDER FUNNEL	1
20	R121RA	EXIT RAMP	1
21	AR122RA-P AR122RA	PLASTIC ROUNDER SCREW ASSEMBLY (STANDARD) *SEE NOTE* METAL ROUNDER SCREW ASSEMBLY (OPTIONAL) *SEE NOTE*	1
22	R141RA	PLASTIC SEAL RING	1
23	R142RA-1	WASHER	1

NOTES:

- For 115V 1 PH machines replacing the gearmotor pictured to the right, order the following:
 - Item #2, Part number 12081, Gearbox 15:1
 - Item #4, Part number 33527, Rounder Motor
 - Not Pictured, Part number 35100, Footpad Conversion Mount
- For machines with a separate gearbox and motor bolted together, 12081 and 33527 are direct replacements.
- [AR122RA-P](#) and [AR122RA](#) also include [R142RA-1](#) (Plastic washer), [R121RA](#) (Exit Ramp), and the bolt, lock washer, and washer for the exit ramp.



MAIN DRIVE MOTORS ON THE R900C		
MACHINE TYPE	PART NUMBER	DESCRIPTION
115V 1PH 60HZ	SEE NOTE ABOVE	SEE NOTE ABOVE
208-220V 1PH/3PH 60HZ	SS256	1 HP/ 100 RPM AC GEARMOTOR 3PH
208-220V 3PH 2HP	EL-1448	2 HP GEAR MOTOR (125RPM)
480V 3PH 2HP 60 HZ	EL-1448	2 HP GEAR MOTOR (125RPM)

Rounder Base Assembly Parts Breakdown

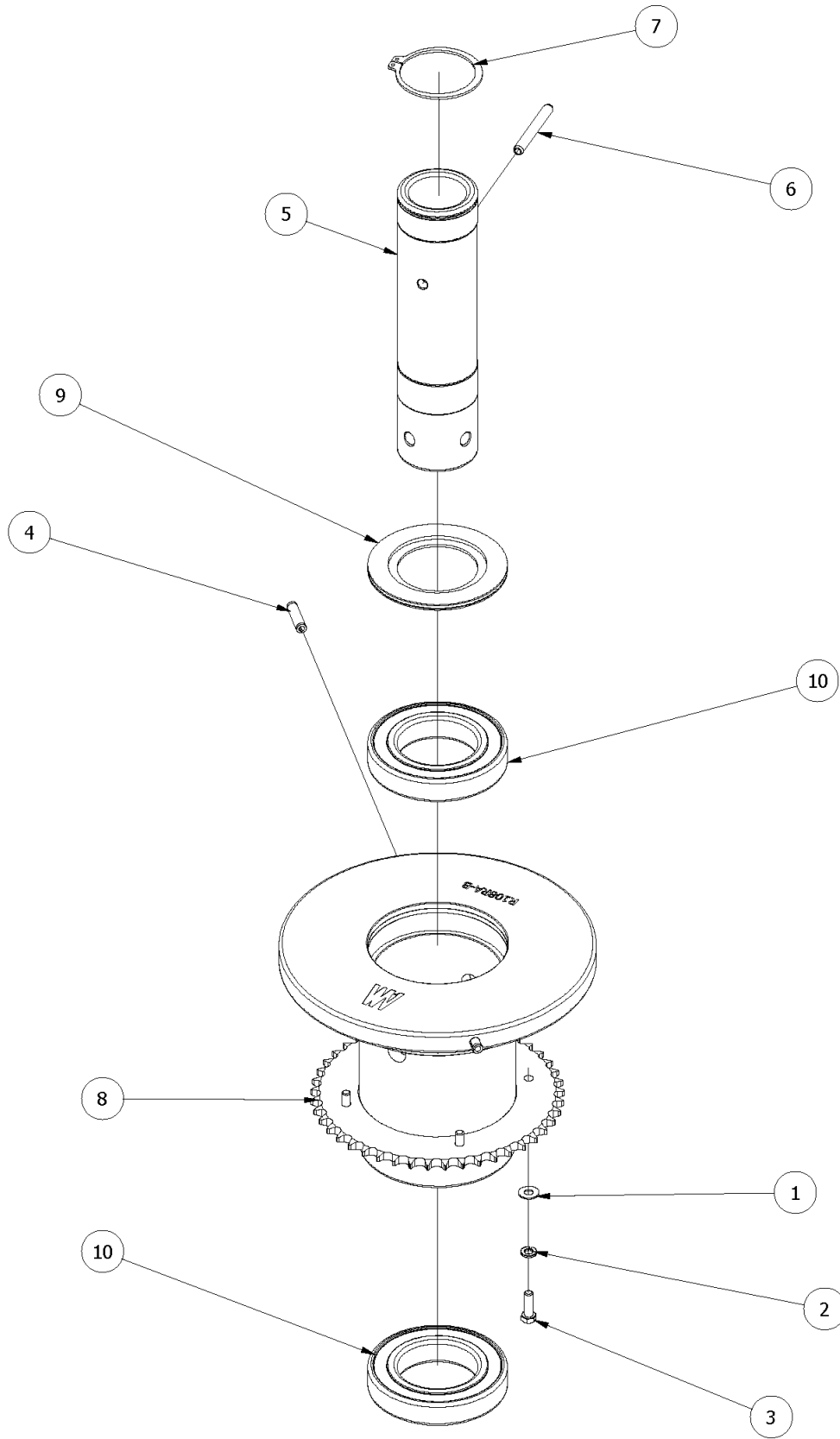

Rounder Base Assembly Parts List

ITEM	PART NO	DESCRIPTION	QTY
1	F0500FW	FLAT WASHER, 5/16"	4
2	F0500LW	LOCK WASHER, 5/16"	4
3	F0504HHCS	HEX HEAD CAP SCREW 5/16-18 X 1" LG.	4
4	F0606RP	ROLL PIN, 3/8" DIA X 1-1/2" LONG	2
5	R108RA-S	SPINDLE ASSEMBLY	1
6	F0612RP	ROLL PIN - 3/8" DIA X 3" LONG	1
7	R145RA	SNAP RING, 3" (PHOSPHOROUS FINISH)	1
8	R109RA	45T 4 HOLE SPROCKET	1
9	R134RA	ROUNDER BASE PLASTIC INSERT W/ORING	1
10	R135RA	BEARING *Recommended to be replaced in pairs*	2

NOTE: The entire assembly can be ordered under AM Manufacturing Part # [R108RA](#) and includes the entire above parts list completely assembled.

Cabinet Assembly Breakdown

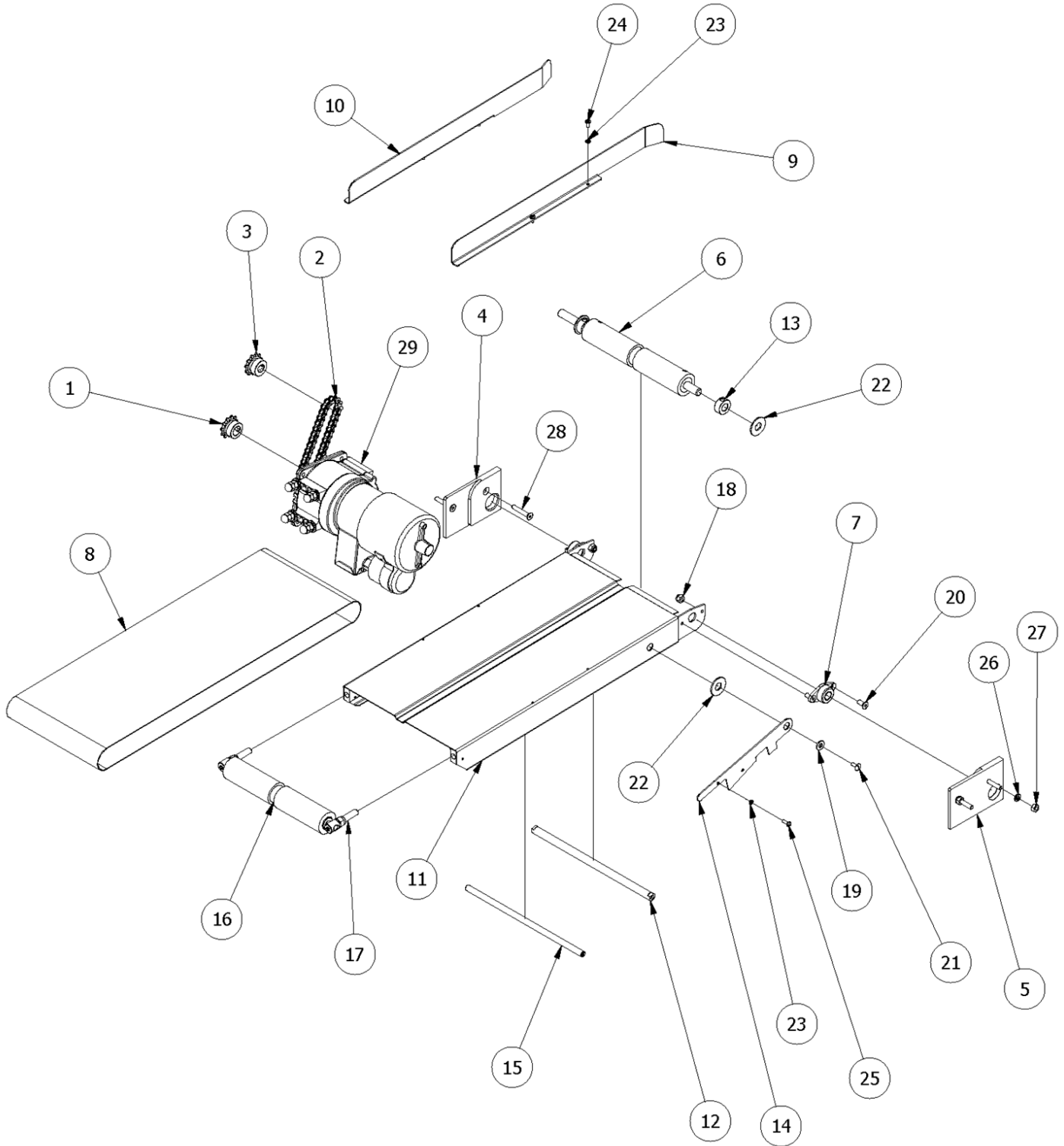

Cabinet Assembly Parts List

ITEM	PART NO	DESCRIPTION	QTY
1	112CA	SPROCKET, 35B11 X 5/8" BORE	1
2	113CA	CHAIN NO.35 AT 16 LINKS PLUS MASTER LINK	1
3	116CA	SPROCKET, 35B11 X 1/2" BORE	1
4	11959	CONVEYOR MOUNTING PLATE (RIGHT)	1
5	11960	CONVEYOR MOUNTING PLATE (LEFT)	1
6	101CA	DRIVE ROLLER ASSEMBLY	1
7	102CA	ALUM. MTG, BRONZE BEARING, 2 HOLE F	2
8	104CA	CONVEYOR BELT (8-3/8"W X 48-1/8" LONG)	1
9	106CAL	LEFT CONVEYOR GUIDE	1
10	106CAR	RIGHT CONVEYOR GUIDE	1
11	118CA	CONVEYOR FRAME ASSEMBLY	1
12	11958	CONVEYOR ELEVATOR SHAFT	1
13	119CA	SHAFT COLLAR, 1/2" ONE PIECE, S.S.	2
14	17914	CONVEYOR ELEVATOR BRACKET	2
15	17915	CONVEYOR ELEVATOR BRACKET SUPPORT SHAFT	1
16	A109CA	IDLER ROLLER ASSEMB.	1
17	A600SC	ROLLER SUPPORT ASSEMBLY	2
18	F0400NLN	NUT, NYLOCK 1/4"	4
19	F0400NW	NYLON FLAT WASHER 1/4"	2
20	F0402.5FSH	FLAT SOCKET HEAD SCREW, 1/4-20 X 5/8" LG.	4
21	F0404TH	1/4-20 X 1/2" LONG TRUSS HEAD	2
22	F0800NW	1/2"ID X 1-1/4"OD NYLON FLAT WASHER	4
23	F9700LW	LOCK WASHER #8	6
24	F9701.5RH	ROUND HEAD, SLOTTED, #8-32 X 3/8"LG	4
25	F9702RH	ROUND HEAD, SLOTTED, #8-32 X 1/2"LG	2
26	F0400LW	LOCK WASHER, 1/4"	26
27	F0400NC	NUT COURSE, 1/4-20	7
28	F0406FSH	FLAT SOCKET HEAD, 1/4 X 1-1/2" LG.	4
29	SS252	1/15HP,70RPM,115-230V MOTOR	1

Cabinet Assembly Breakdown

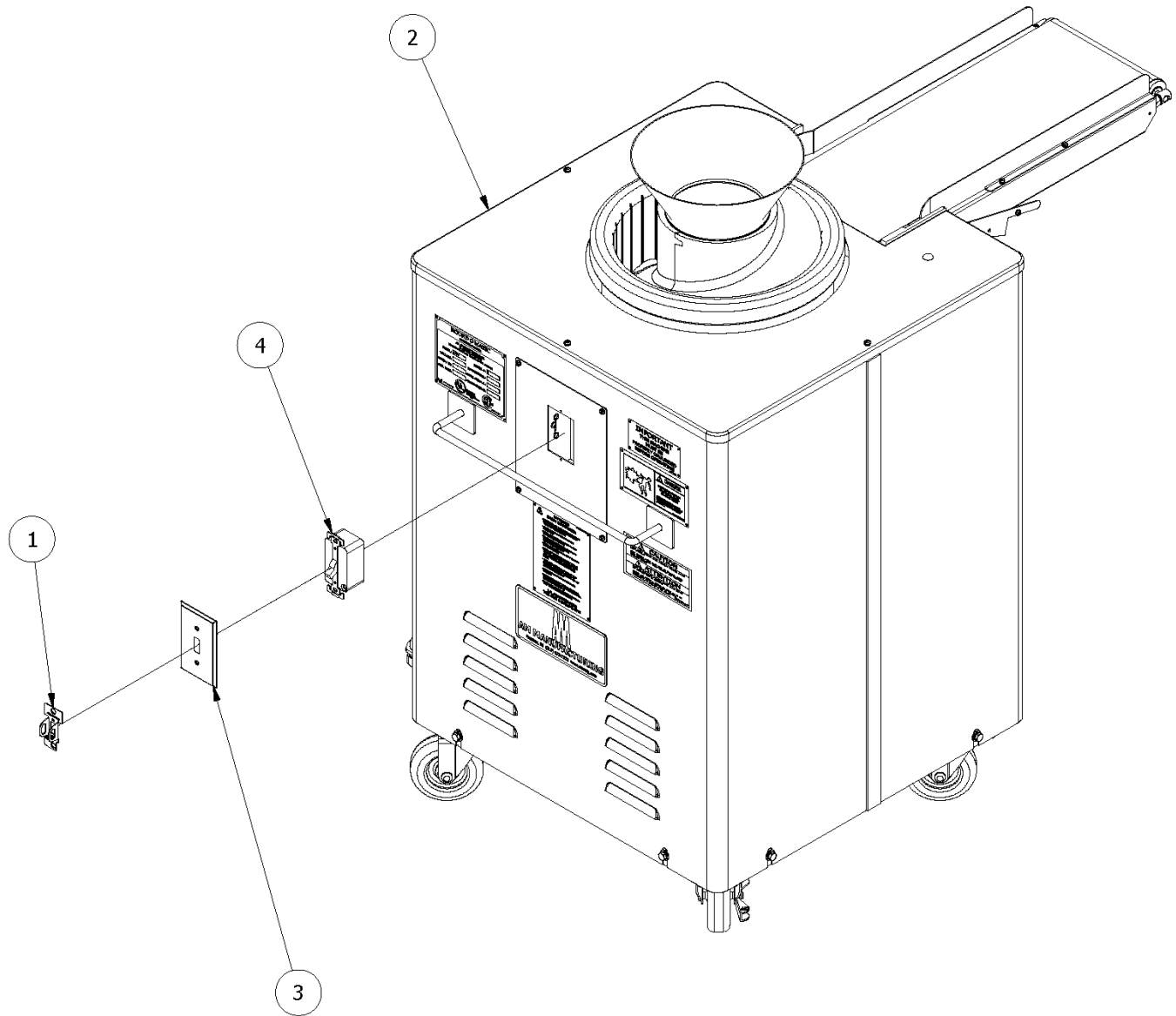

Cabinet Assembly Parts List

ITEM	PART NO	DESCRIPTION	QTY
1	R406CA	LOCKING ATTACHMENT, SWITCH	1
2	R411CA	TOP COVER	1
3	SS115	SINGLE SWITCH COVER PLATE, S.S.	1
4	SS212	MANUAL MOTOR STARTER SINGLE SWITCH *SEE TABLE BELOW*	1

SWITCHES & OVERLOADS			
MACHINE TYPE	MACHINE TYPE	OVERLOAD	DESCRIPTION
115V 1PH 60HZ	115V 1PH 60HZ	EL-1344	OVERLOAD HEATER (6.03 AMPS)
208-220V 1PH 60HZ	208-220V 1PH 60HZ	EL-1344	OVERLOAD HEATER (6.03 AMPS)
208-220V 3PH 60HZ	208-220V 3PH 60HZ	EL-1373	OVERLOAD HEATER (4.51 AMPS)
208-220V 3PH 2HP	208-220V 3PH 2HP	EL-1370	OVERLOAD HEATER (8.70 AMPS)
480V 3PH 2HP 60 HZ	480V 3PH 2HP 60 HZ	*CONTACT MANUFACTURER*	
CONTACT AM MANUFACTURING IF YOUR MACHINE ELECTRICAL SETUP IS NOT LISTED			

SOFT START/TRANSFORMER			
MACHINE TYPE	SOFT START	TRANSFORMER	DESCRIPTION
208-220V 1PH/3PH 60HZ	SS384	N/A	N/A
208-220V 3PH 2HP	SS384	EL-1943	TRANSFORMER -150VA (240Vac, 480Vac)
480V 3PH 2HP 60 HZ	SS384	EL-1943	TRANSFORMER -150VA (240Vac, 480Vac)

3 PH MACHINES: HOUR COUNTER (IF APPLICABLE)	
PART NUMBER	DESCRIPTION
EL-1490	ELECTRONIC HOUR METER

Schematics Sheet 1

NOTE:
 115Vac OR 208-230Vac / 60Hz / Single Phase
 115Vac Amperage: 10.4Amps
 208-230Vac Amperage: 5.2Amps

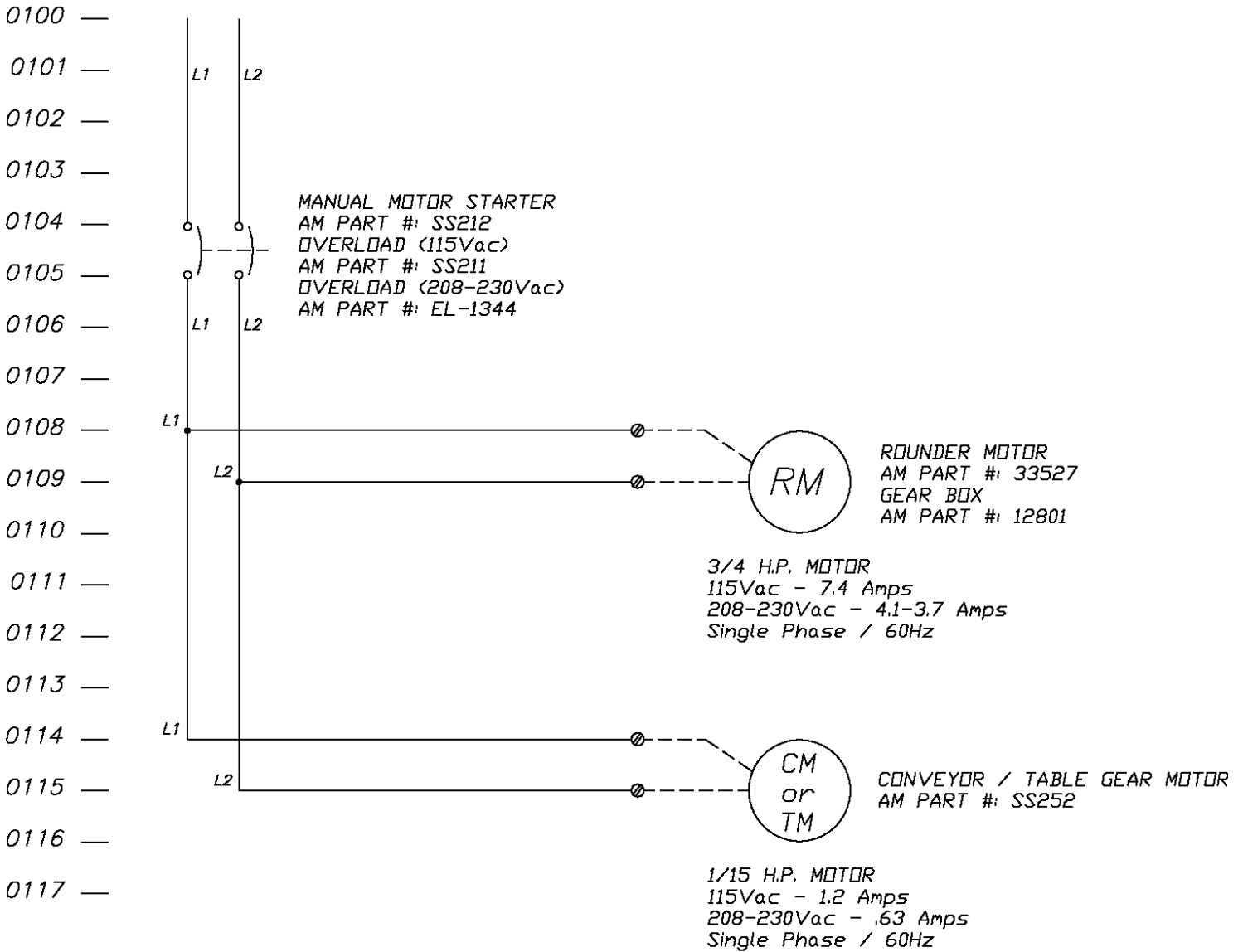

Schematics Sheet 2

NOTE:
208-230Vac / 60Hz / Three Phase
Amperage: 5.7Amps

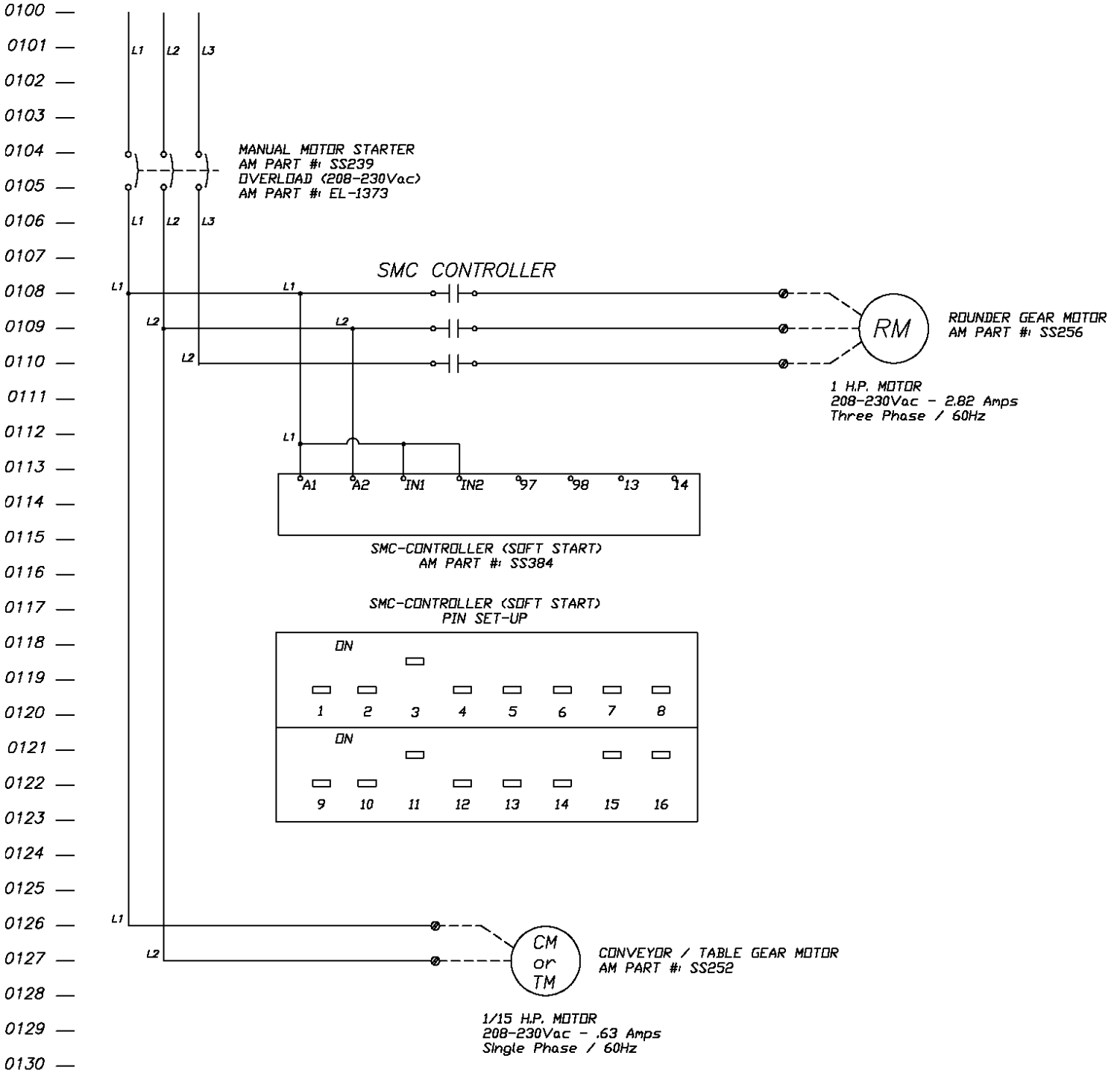

Schematics Sheet 3

NOTE:
208-230Vac / 60Hz / Three Phase
Amperage: 6.7Amps

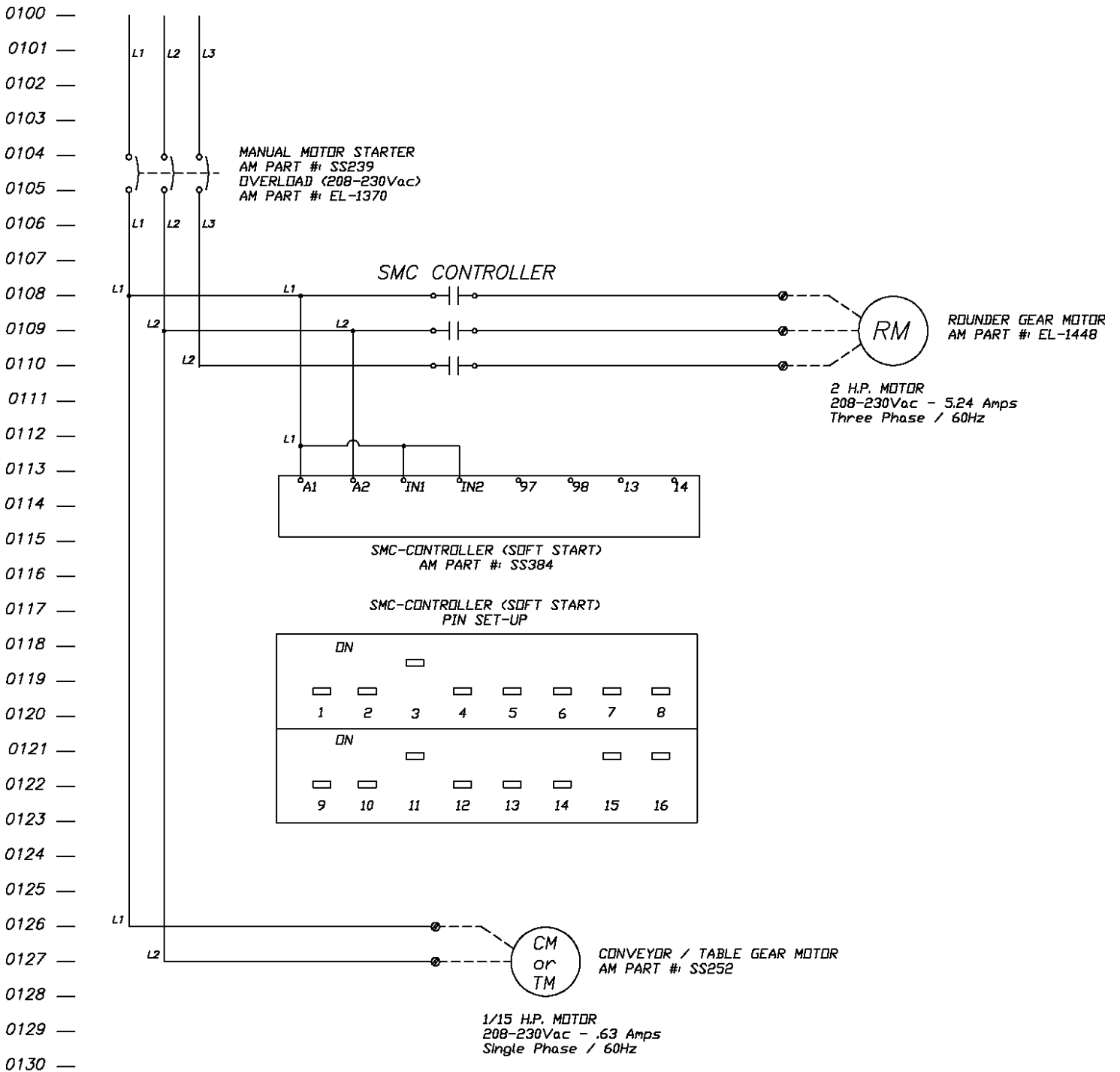

Ordering replacement parts

IMPORTANT:

Only use factory supplied replacement parts to maintain machine safety, performance, and sanitary conditions.

Use of non-approved parts may void manufacturer's warranty.

TO ORDER REPLACEMENT PARTS ALWAYS:

1. Check the machine to identify missing, damaged, or non-functional parts including guards, warning labels, and instructions.
2. Compare the list with the parts diagrams supplied.
3. Record the complete model and serial number of the unit.
4. Call A.M. manufacturing (219) 472-7273 and provide all the information noted above to expedite order processing and help reduce shipping costs.
5. Provide complete details for (ship to) and (bill to) information. To assist prompt delivery, specify the type of carrier speed for shipment.

AM Manufacturing accepts Visa, Mastercard, and American Express.

