

Service



This manual is to be used by qualified appliance technicians only. ACP does not assume any responsibility for property damage or personal injury for improper service procedures done by an unqualified person.

RCS/RFS Commercial Microwave Ovens

This Base Manual covers general information

Refer to individual Technical Sheet
for information on specific models

This manual includes, but is
not limited to the following:

RCS10DA	P1330201M
RCS10DA	P2000702M
RCS10MPA	P1330202M
RCS10MPA	P2000704M
RCS10A	P1330203M
RCS10PBDA	P1330204M
RCS10MPSA	P1330205M
RCS10MPSA	P2000705M
RFS12MPSA	P1330206M
RFS12SW2A	P1330208M
RFS10SW2A	P1330232M

Important Information

Important Notices for Servicers and Consumers

ACP will not be responsible for personal injury or property damage from improper service procedures. Pride and workmanship go into every product to provide our customers with quality products. It is possible, however, that during its lifetime a product may require service. Products should be serviced only by a qualified service technician who is familiar with the safety procedures required in the repair and who is equipped with the proper tools, parts, testing instruments and the appropriate service information. IT IS THE TECHNICIANS RESPONSIBILITY TO REVIEW ALL APPROPRIATE SERVICE INFORMATION BEFORE BEGINNING REPAIRS.

 WARNING
To avoid risk of severe personal injury or death, disconnect power before working/servicing on appliance to avoid electrical shock.

To locate an authorized servicer please contact:

ComServ Support Center



Web Site
WWW.ACPSOLUTIONS.COM

Telephone Number
..... 1-866-426-2621 or 319-368-8195

E-Mail: commercialservice@acpsolutions.com

Recognize Safety Symbols, Words, and Labels

 DANGER

DANGER— Immediate hazards which WILL result in severe personal injury or death.

 WARNING
--

WARNING— Hazards or unsafe practices which COULD result in severe personal injury or death.

 CAUTION
--

CAUTION— Hazards or unsafe practices which COULD result in minor personal injury, product or property damage.

Table of Contents

Important Information	2	Disassembly Procedures	
Important Safety Information	4	Disconnecting Wire Terminals	25
Grounding Instructions	7	Outer Case	25
Servicing of Grounded Products	8	Door Assembly	26
Wiring	8	Door Disassembly	26
Proper Grounding and Polarization of		Control Panel Removal.....	27
120 Volts Wall Outlets	8	Interlock Switches	27
Explanation	8	H.V. Capacitor	28
Test Procedures	8	Diode	28
General Test Information	8	Transformer	29
General Information		Fuse / Fuse Block /Filter Assembly	29
Unpacking Equipment	9	Magnetron	29
Equipment Placement	9	Blower Motor or Wheel	30
Radio Interference	9	Splatter Shield	30
Oven Features	9	Antenna	30
Model Identification	10	Stirrer Motor	30
Service	10	Magnetron Thermal Cut-Out (TCO)	31
Parts and Accessories	10	Cavity Thermal Fuse	31
Troubleshooting Procedures	11-16	Tray Replacement	31
Testing Procedures	20-23	Oven Light Removal	31
Power Test	24	Appendix A	
		Quick Reference Guide Dial Model	A-2
		Quick Reference Guide Digital Dial Model	A-3
		Quick Reference Guide Electronic Model	A-5

Important Safety Information

WARNING

Read the following information to avoid possible exposure to microwave radiation:

The basic design of the Microwave Oven makes it an inherently safe device to both use and service.

However, there are some precautions which should be followed when servicing the Microwave Oven to maintain this safety. These are as follows:

1. Always operate the unit from an adequately grounded outlet. Do not operate on a two-wire extension cord.
2. Before servicing the unit (if unit is operable) perform the microwave leakage test.
3. The oven should never be operated if the door does not fit properly against the seal, the hinges or hinge bearings are damaged or broken; the choke is damaged, (pieces missing, etc.); or any other visible damage can be noted. Check the choke area to ensure that this area is clean and free of all foreign matter.
4. If the oven operates with the door open and produces microwave energy, take the following steps:
 - A. Tell the user not to operate the oven.
 - B. Contact ACP immediately.
5. Always have the oven disconnected when the outer case is removed except when making the "live" tests called for in this Service Manual. Do not reach into the equipment area while the unit is energized. Make all connections for the test and check them for tightness before plugging the cord into the outlet.
6. Always ground the capacitors on the magnetron filter box with an insulated-handle screwdriver before working in the high voltage area of the equipment compartment. Some types of failures will leave a charge in these capacitors and the discharge could cause a reflex action which could make you injure yourself.
7. Always remember that in the area of the transformer there is HIGH VOLTAGE. When the unit is operating keep this area clear and free of anything which could possibly cause an arc or ground, etc.
8. Do not for any reason defeat the interlock switches there is not a valid reason for this action at anytime; nor will it be condoned by ACP.
9. **IMPORTANT:** Before returning a unit to a customer, be sure to check for proper switch interlock action.
10. Before returning a unit to a customer, verify that the door spacing is reasonably uniform along the top, bottom, and sides, and that it measure 1/64"/0.5mm or less.
11. Microwave ovens should never be operated with any components removed and/or bypassed or when any of the safety interlocks are found to be failing or when any of the seal surfaces are failing, missing or damaged.
12. All microwave ovens meet all requirements of the radiation control for Health and Safety Act of 1968. Due to measurement uncertainties, the maximum leakage for the field will be 4mw/cm².
13. To ensure that the unit does not emit excessive microwave leakage and to meet the Department of Health and Human Services guidelines, check the oven for microwave leakage using a leakage monitor. The maximum leakage level allowed when following those instructions is 4mw/cm².
14. If servicer encounters an emission reading over 4mw/cm², the servicer is to cease repair and contact the Commercial Support Center immediately for further direction. ACP will contact the proper Government Agency upon verification of the test results.

Important Safety Information



Recognize this symbol as a SAFETY message



WARNING

When using electrical equipment, basic safety precautions should be followed to reduce the risk of burns, electrical shock, fire, or injury to persons.

1. **READ** all instructions before using equipment.
2. **READ AND FOLLOW** the specific “**PRECAUTIONS TO AVOID POSSIBLE EXPOSURE TO EXCESSIVE MICROWAVE ENERGY**”.
3. This equipment **MUST BE GROUNDED**. Connect only to properly GROUNDED outlet. See “**GROUNDED INSTRUCTIONS**”.
4. Install or locate this equipment **ONLY** in accordance with the installation instructions in this manual.
5. Some products such as whole eggs and sealed containers, for example, closed glass jars may explode and **SHOULD NOT** be **HEATED** in this oven.
6. Use this equipment **ONLY** for its intended use as described in this manual. Do not use corrosive chemicals or vapors in this equipment. This type of oven is specifically designed to heat or cook. It is not designed for industrial or laboratory use.
7. As with any equipment, **CLOSE SUPERVISION** is necessary when used by **CHILDREN**.
8. **DO NOT** operate this equipment if it has a damaged cord or plug, if it is not working properly, or if it has been damaged or dropped.
9. This equipment, including power cord, must be serviced **ONLY** by qualified service personnel. Special tools are required to service equipment. Contact nearest authorized service facility for examination, repair, or adjustment.
10. **DO NOT** cover or block filter or other openings on equipment.
11. **DO NOT** store this equipment outdoors. **DO NOT** use this product near water, for example, near a kitchen sink, in a wet basement, or near a swimming pool, and the like.
12. **DO NOT** immerse cord or plug in water.
13. Keep cord **AWAY** from **HEATED** surfaces.
14. **DO NOT** let cord hang over edge of table or counter.
15. See door cleaning instructions in “Care and Cleaning” section.
16. **For commercial use only.**



CAUTION

To reduce risk of fire in the oven cavity:

- a. **DO NOT** overcook food. Carefully attend equipment if paper, plastic, or other combustible materials are placed inside the oven to facilitate cooking.
- b. Remove wire twist-ties from paper or plastic bags before placing bag in oven.
- c. **KEEP** oven **DOOR CLOSED**, turn oven off, and disconnect the power cord, or shut off power at the fuse or circuit breaker panel, if materials inside the oven should ignite. Fire may spread if door is opened.
- d. **DO NOT** use the cavity for storage. **DO NOT** leave paper products, cooking utensils, or food in oven.

SAVE THESE INSTRUCTIONS

Important Safety Information



CAUTION

To avoid risk of personal injury or property damage, observe the following:

1. Briskly stir or pour liquids before heating with microwave energy to prevent spontaneous boiling or eruption. Do not overheat. If air is not mixed into a liquid, liquid can erupt in oven or after removal from oven.
2. Do not deep fat fry in oven. Fat could overheat and be hazardous to handle.
3. Do not cook or reheat eggs in shell or with an unbroken yolk using microwave energy. Pressure may build up and erupt. Pierce yolk with fork or knife before cooking.
4. Pierce skin of potatoes, tomatoes, and similar foods before cooking with microwave energy. When skin is pierced, steam escapes evenly.
5. Do not operate equipment without load or food in oven cavity.
6. Use only popcorn in packages designed and labeled for microwave use. Popping time varies depending on oven wattage. Do not continue to heat after popping has stopped. Popcorn will scorch or burn. Do not leave oven unattended.
7. Do not use regular cooking thermometers in oven. Most cooking thermometers contain mercury and may cause an electrical arc, malfunction, or damage to oven.
8. Do not heat baby bottles in oven.
9. Do not use metal utensils in oven.
10. Never use paper, plastic, or other combustible materials that are not intended for cooking.
11. When cooking with paper, plastic, or other combustible materials, follow manufacturer's recommendations on product use.
12. Do not use paper towels which contain nylon or other synthetic fibers. Heated synthetics could melt and cause paper to ignite.
13. Do not heat sealed containers or plastic bags in oven. Food or liquid could expand quickly and cause container or bag to break. Pierce or open container or bag before heating.
14. To avoid pacemaker malfunction, consult physician or pacemaker manufacturer about effects of microwave energy on pacemaker.

PRECAUTIONS TO AVOID POSSIBLE EXPOSURE TO EXCESSIVE MICROWAVE ENERGY

- a. **DO NOT** attempt to operate this oven with the door open since open-door operation can result in harmful exposure to microwave energy. It is important not to defeat or tamper with the safety interlocks.
- b. **DO NOT** place any object between the oven front face and the door or allow soil or cleaner residue to accumulate on sealing surfaces.
- c. **DO NOT** operate the oven if it is damaged. It is particularly important that the oven door close properly and that there is no damage to the: (1) door (bent), (2) hinges and latches (broken or loosened), (3) door seals and sealing surfaces.
- d. The oven should **NOT** be adjusted or repaired by anyone except properly qualified service personnel.

SAVE THESE INSTRUCTIONS

Important Safety Information

WARNING

Precautions to be observed before and during servicing to avoid possible exposure to excessive microwave energy, or electrical shock disconnect power to oven.

- Do not operate or allow oven to be operated with door open.
- Make the following safety checks on all ovens to be serviced before activating the magnetron or other microwave source, and make repairs as necessary:
 - Interlock operation
 - Proper door closing
 - Seal and sealing surfaces (arcing, wear, and other damage)
 - Damage to or loosening of hinges and latches
 - Evidence of dropping or abuse
- Before turning on microwave power for any service test or inspection within the microwave generating compartments, check the magnetron, waveguide or transmission line, and cavity for proper alignment, integrity, and connections.
- Any failed or misadjusted components in the interlock, monitor, door seal, and microwave generation and transmission systems shall be repaired, replaced or adjusted by procedures described in this manual before oven is released to the consumer.
- Check microwave leakage to verify compliance with the federal performance standard should be performed on each oven prior to release to the consumer.

WARNING

To avoid risk of electrical shock, injury or death; make sure these grounding instructions are followed.

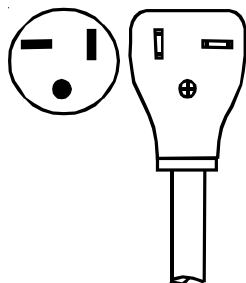

NEMA 5-20R/5-20P
120V-20AMP

WARNING

Do not remove grounding prong when installing grounded appliance in a home or business that does not have three wire grounding receptacle, under no condition is grounding prong to be cut off or removed. It is the personal responsibility of the consumer to contact a qualified electrician and have properly grounded three prong wall receptacle installed in accordance with appropriate electrical codes.

WARNING

To avoid the risk of electrical shock or death, do not alter the plug.

WARNING

To avoid the risk of electrical shock or death, this equipment must be grounded.

This equipment **MUST** be grounded. In the event of an electrical short circuit, grounding reduces the risk of electric shock by providing an escape wire for the electric current. This oven is equipped with a cord having a grounding wire with a grounding plug. The plug must be plugged into an outlet that is properly installed and grounded.

Consult a qualified electrician or servicer if grounding instructions are not completely understood, or if doubt exists as to whether the equipment is properly grounded.

Do not use an extension cord. If the product power cord is too short, have a qualified electrician install a three-slot receptacle. This oven should be plugged into a separate 60 hertz circuit with the electrical rating as shown in the appropriate drawing. Models operate with a 120 supply voltage. When a microwave oven is on a circuit with other equipment, an increase in cooking times may be required and fuses can be blown.

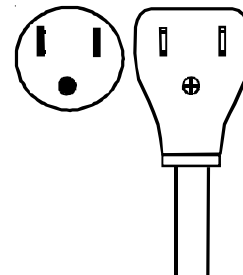

NEMA 5-15R/5-15P
120V-15AMP

Important Safety Information

Servicing of Grounded Products

The standard accepted color coding for grounding wires is GREEN or GREEN WITH YELLOW STRIPE. These ground leads are NOT to be used as current carrying conductors. It is extremely important that the technician replace any and all grounds prior to completion of the service call. Under no condition should ground wire be left off causing a potential hazard to technicians and consumer.

Wiring

A good service practice is never route wiring over terminals and/ or sharp edges. This applies to any wiring without regard to the circuit voltage. Wire installation material and thickness is designed and regulated for electrical spacing purpose only, but cannot always be relied upon because of possible cuts and/or abrasions, which can occur during servicing.

 **WARNING**

To avoid risk of electrical shock, personal injury or death; verify the oven is properly grounded and polarized.

Explanation

Polarization –This means that the larger slot must be neutral and the small slot must be hot (live).

Mispolarized –The outlet is miswired so that the larger slot is hot (live) and the smaller slot is neutral.

Grounded –This means the round hole connection is connected to earth ground through a connection to the main power panel.

Ungrounded –The round hole connection is not complete to earth ground and/or the main power panel.

 **CAUTION**

To avoid risk of electrical shock, personal injury or property damage; wiring changes or grounding of wall outlet are to be made only by a qualified electrician.

Proper Grounding and Polarization of 120 Volts Wall Outlets

For the safety of our customers and the service technician ALL appliances have a three-prong power cord and MUST be connected to a properly polarized and grounded wall outlet.

This information was written for those who do not understand grounding and polarization of a wall outlet.

A 120 volt wall outlet must always be wired as shown below.

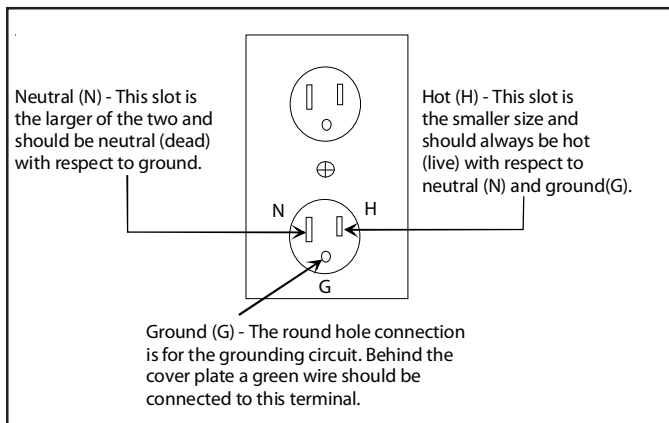

General Information

Unpacking Equipment

- Inspect equipment for damage such as dents in door or dents inside oven cavity.
- Report any dents or breakage to source of purchase immediately. Do not attempt to use oven if damaged.
- Remove all materials from oven interior.

Equipment Placement

- Do not install equipment next to or above source of heat, such as pizza oven or deep fat fryer. This could cause microwave oven to operate improperly and could shorten life of electrical parts.
- Do not block or obstruct air filter. Allow access for cleaning.
- Install on level countertop surface.

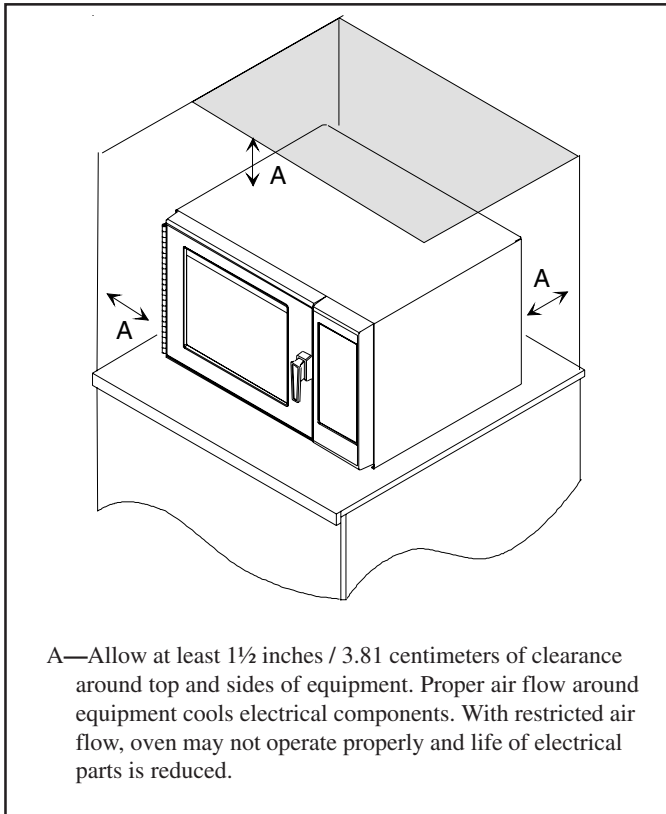

Radio Interference

Microwave operation may cause interference to radio, television, or similar equipment. Reduce or eliminate interference by doing the following:

- Clean door and sealing surfaces of oven according to instructions in “Care and Cleaning” section.
- Place radio, television, etc. as far as possible from oven.
- Use a properly installed antenna on radio, television, etc. to obtain stronger signal reception.

Oven Features

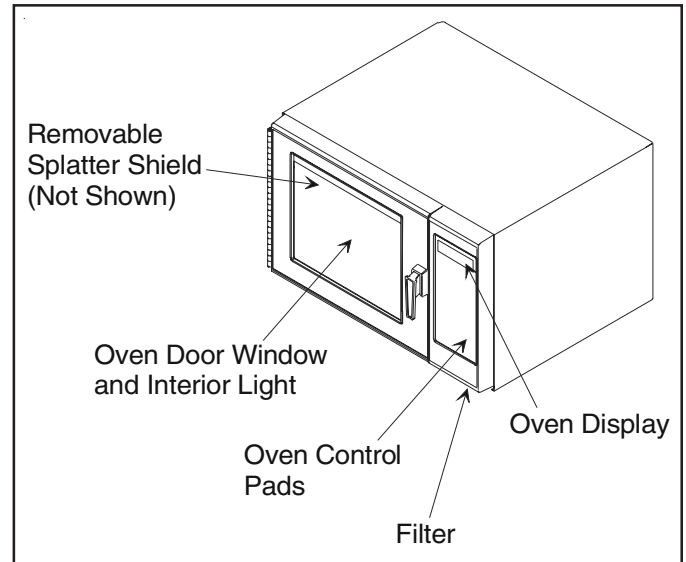

General Information

Model Identification

- For ACP product call 1-866-426-2621 or visit the Web Site at www.acpsolutions.com

When contacting for service support, provide product information located on rating plate. Record the following:

Model Number: _____
Manufacturing Number: _____
Serial or S/N Number: _____
Date of purchase: _____
Dealer's name and address: _____

Service

Keep a copy of sales receipt for future reference or in case warranty service is required. To locate an authorized servicer:

- For ACP product call 1-866-426-2621 or visit the Web Site at www.acpsolutions.com

Warranty service must be performed by an authorized servicer. We also recommend contacting an authorized servicer, if service is required after warranty expires.

Parts and Accessories

Purchase replacement parts and accessories over the phone. To order accessories for your product contact your local product distributor or visit the Web site at www.amanacommercial.com.

Troubleshooting Procedures

When you get a complaint from customers, evaluate the complaint carefully. If the following symptoms apply, instruct the customer in the proper use of the microwave oven. This can eliminate an unnecessary service call.



CAUTION

- Verify proper earthing before checking for trouble.
- Be careful of the high voltage circuit.
- Discharge the high voltage capacitor.
- When checking the continuity of the switches or of the high voltage transformer, disconnect one lead wire from these parts and then check continuity with the AC plug removed. To do otherwise may result in a false reading or damage to your meter.
- Do not touch any part of the circuit on the controller, since static electric discharge may damage the control panel. Always touch yourself to earth while working on this panel to discharge any static charge built up in your body.

Condition	Cause	Remedy
Microwave oven does not work.	<ul style="list-style-type: none"> • Inserting multiple plugs into one outlet and using them at the same time (blown fuse or breaker). • Microwave oven plug is not inserted tightly. 	<ul style="list-style-type: none"> • Avoid using other electrical appliances when you use the microwave oven. • Insert microwave oven plug securely.
Output power is too low.	<ul style="list-style-type: none"> • Low AC input voltage. • Food temperature is too low. 	<ul style="list-style-type: none"> • Use the microwave oven at adequate line voltage. • This may not be a defect. It is possible that the food should be cooked for a longer time period.
Sparks occur.	<ul style="list-style-type: none"> • Using metallic ware and allowing it to touch the oven wall. • Ceramic ware trimmed in gold or silver is used. 	<ul style="list-style-type: none"> • Do not use metallic ware for cooking. • Do not use any type of cookware with metallic trimming.
Uneven cooking.	Inconsistent food thickness, inconsistent fat or moisture distribution within the food products.	<ul style="list-style-type: none"> • Use plastic wrap or lid. • Stir once or twice while cooking soup, cocoa, milk, etc.

Troubleshooting Procedures

Trouble 1: The following visual conditions indicate a probable failed control circuit.

1. Incomplete segments.
 - Segment missing.
 - Partial segment missing.
 - Digit flickering (Note: Slight flickering is normal.)
2. Colon does not turn on or blink.
3. A distinct change in the brightness of one or more numbers in display.
4. One or more digits in the display are not lighting.
5. Display indicates a number different from one touched, for example, key in 5 and 3 appears in the display.
6. Specific numbers (for example 7 or 9) will not display when key pad is touched.
7. Display does not count down with time blinking or up with clock operation.
8. Display obviously jumps in time while counting down.
9. Display counts down too fast while cooking.
10. Each indicator light does not turn on after setting cooking cycle.
11. Display time of day does not reappear when cooking is finished.

Condition	Check	Result	Cause	Remedy
No input can be programmed.	Check the connection between keypad and controller.	<ul style="list-style-type: none"> • Continuity • No continuity 	<ul style="list-style-type: none"> • Failed controller. • Loose connection. 	<ul style="list-style-type: none"> • Replace controller. • Repair connection.
<ol style="list-style-type: none"> 1. Some inputs cannot be programmed. 2. Display shows a number or figure different from one touched. 3. Random programming when touching other pads. 4. Display is fixed at some figure and can not accept any input. 	Replace keypad and check operation.	<ul style="list-style-type: none"> • Everything works as specified. • Still have trouble. 	<ul style="list-style-type: none"> • Failed keypad. • Failed controller. 	<ul style="list-style-type: none"> • Replace keypad. • Replace controller.

Troubleshooting Procedures (Electronic Models)

Trouble 2: Oven does not operate at all, display window does not display any digits, and no input is accepted.

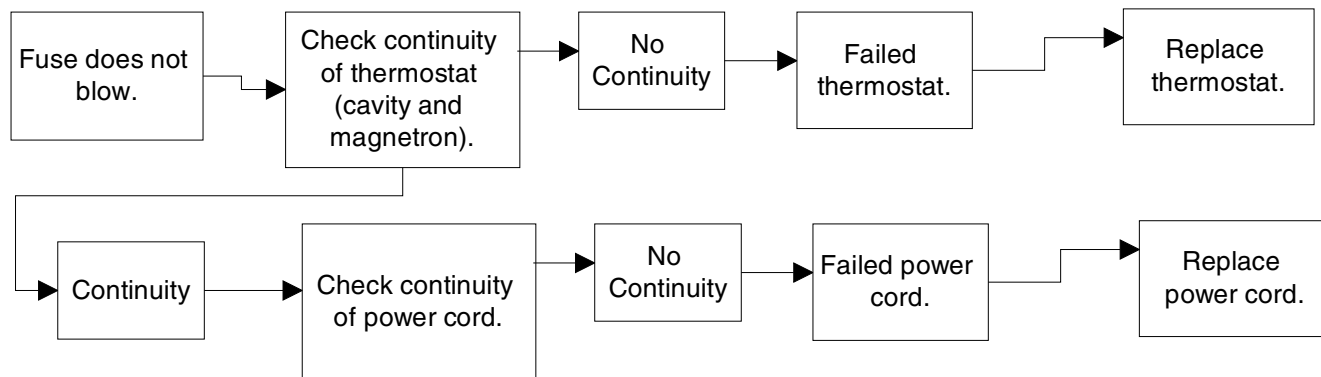
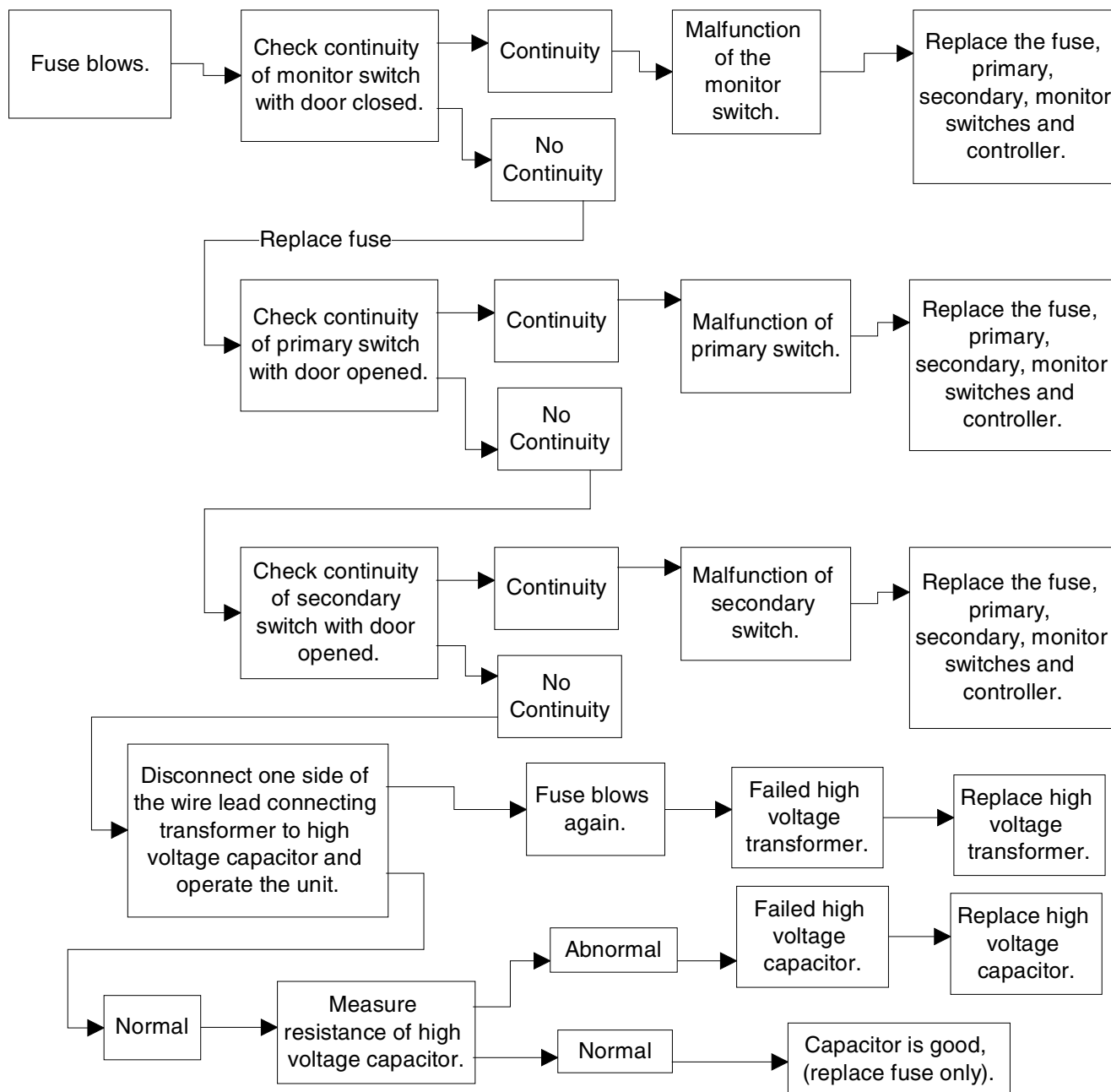

Troubleshooting Procedures (Electronic Models)

Trouble 3: Display shows all digits programmed, but does not start cooking when the START pad is pressed.

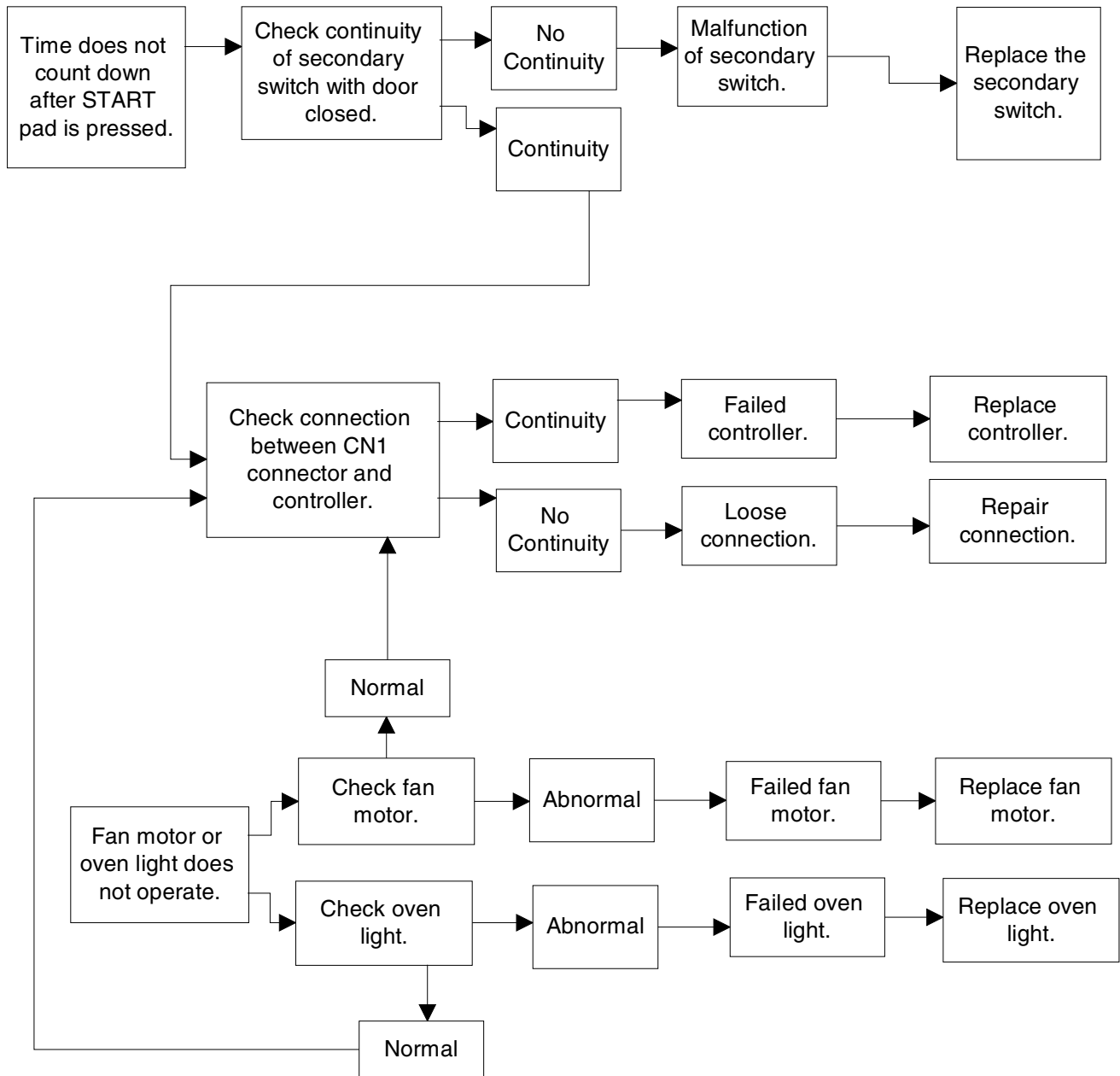

Troubleshooting Procedures (Electronic Models)

Trouble 4: Oven operates with little or no heat.

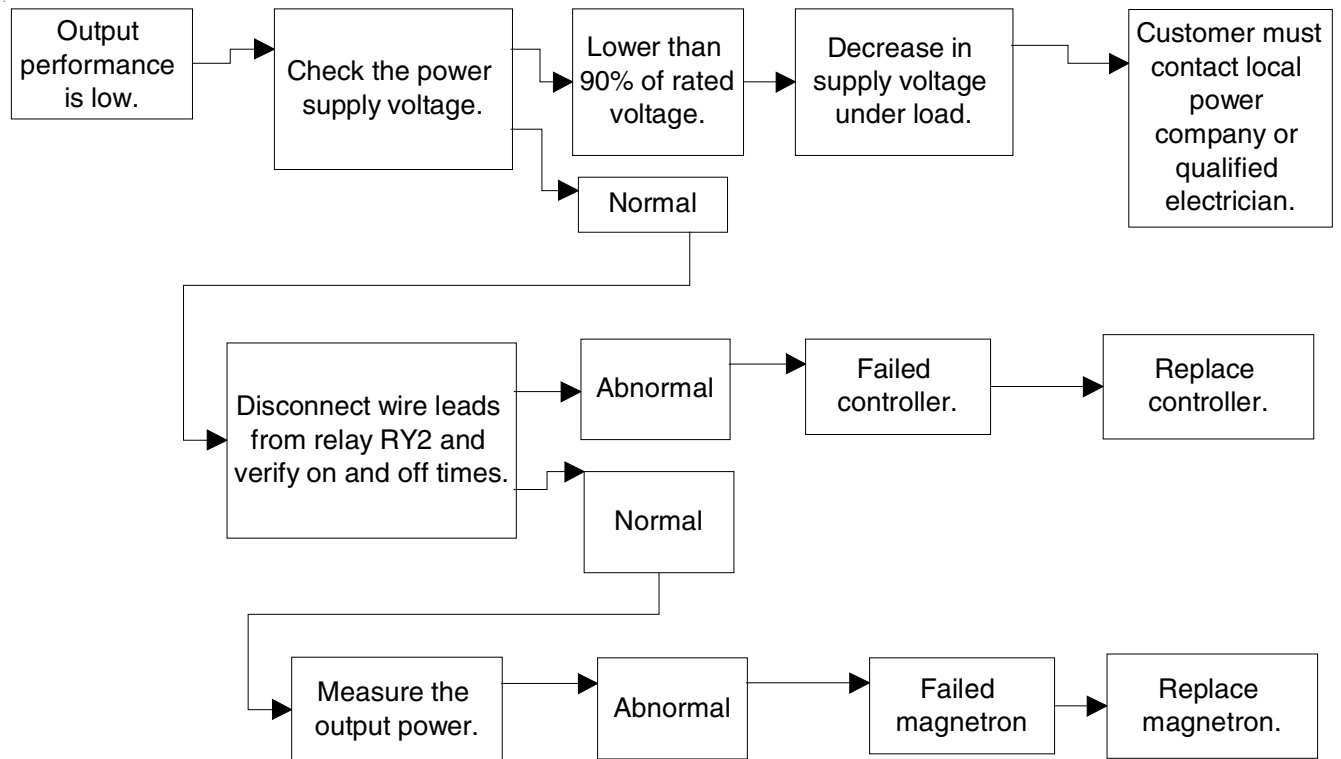

NOTE: Simple test of power output can be conducted by heating one liter of water for 33 seconds. Refer to Power Test on page 24 of this manual.

Troubleshooting Procedures (Electronic Models)



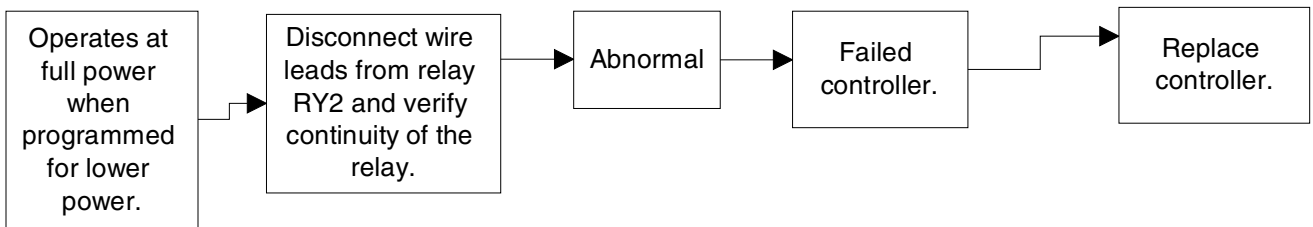
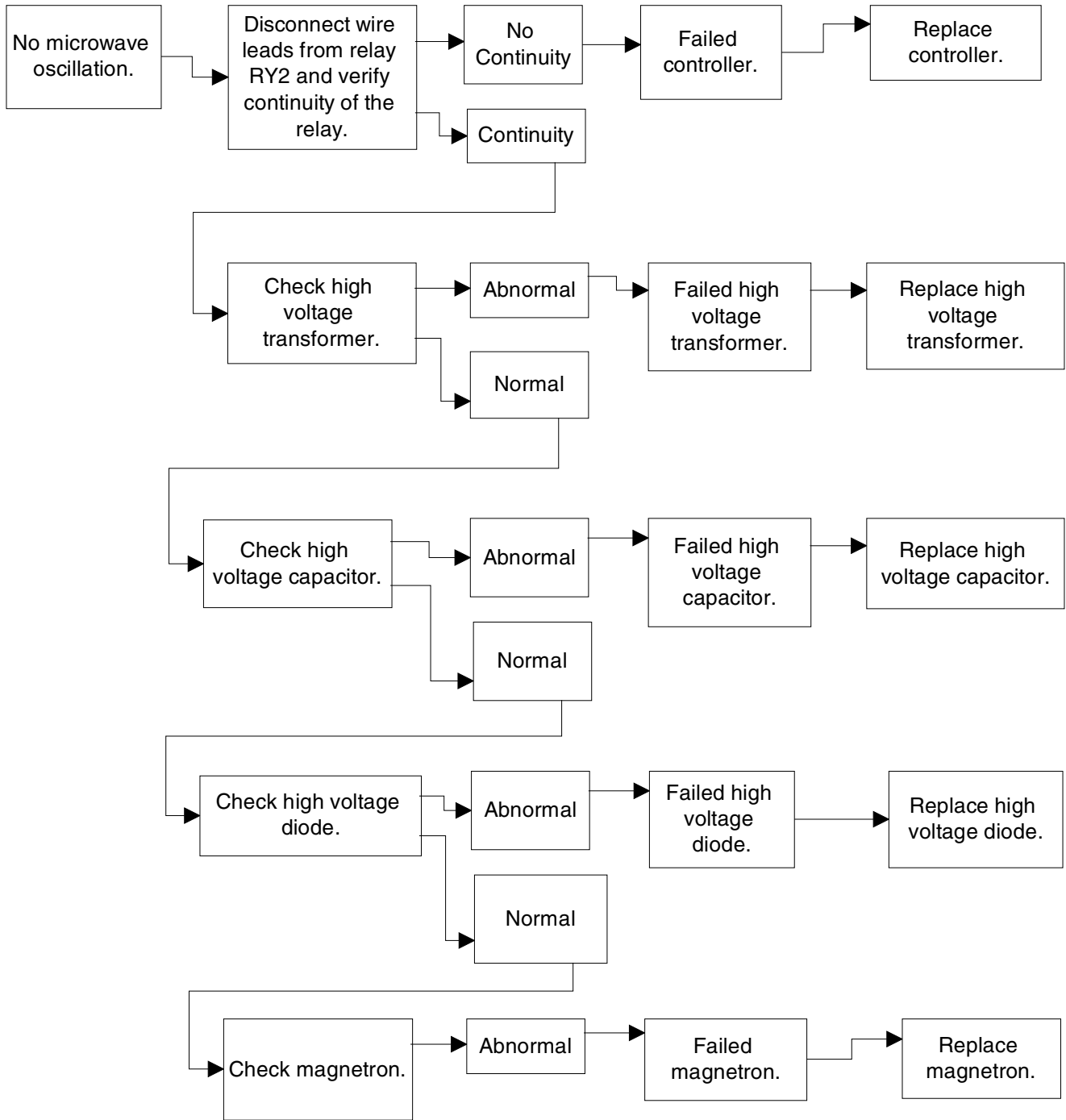

Trouble 5: No microwave oscillation even when oven light and fan motor operate.

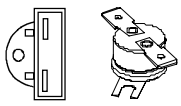

Testing Procedures

⚠ WARNING

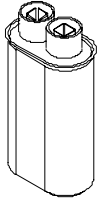
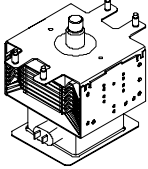
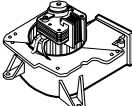
To avoid risk of electrical shock, personal injury or death; disconnect power to oven and discharge capacitor before servicing, unless testing requires power.

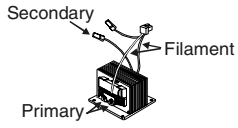
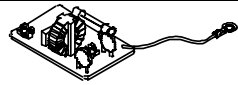
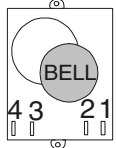
Illustration	Component	Testing	Results
	Thermal cutout	Disconnect all wires from TCO. Measure resistance across terminals. Cavity TCO..... Magnetron TCO.....	Closed at 32°F (0°C) and Opens at 230°F (110°C) Closed at 140°F (60°C) and Opens at 320°F (160°C)
	Diode	Discharge Capacitor Remove diode lead from capacitor and connect ohmmeter. Reverse leads for second test.	Infinite resistance should be measured in one direction and 50KΩ or more in the opposite direction. NOTE: Ohmmeter must contain a battery of 6 volts minimum.
	Capacitor	Discharge Capacitor Remove wires from capacitor terminals and connect ohmmeter, set on highest resistance scale to terminals. Also check between each terminal and capacitor case.	Between Terminals: Meter should momentarily deflect towards zero then return to over 5 MΩ. If no deflection occurs, or if continuous deflection occurs, replace capacitor. Terminal to Case: Infinite resistance
	Magnetron	Discharge Capacitor Remove wires from magnetron and connect ohmmeter to terminals. Also check between each terminal and ground.	Between Terminals: Less than 1 Ω Each terminal to ground measures Infinite resistance. Note: This test is not conclusive. If oven does not heat and all other components test good replace the magnetron and retest.
	Blower motor	Remove all wires from motor. Measure resistance across coil	Approximately 14 – 21 Ω
	Stirrer motor	Remove all wires from motor. Measure resistance across terminals	Approximately 3 – 3.5 KΩ
	Transformer	Discharge Capacitor Remove all wires from terminals. Measure resistance from: Primary Filament..... Secondary to Ground screw on transformer stack.....	Less than <1 Ω Less than <1 Ω Approximately 100 – 120 Ω
	Noise filter board	Power In terminals..... Power Out terminals.....	120 VAC 120 VAC If no power in, check power outlet. If no power out, check fuses.
	6 minute timer	Remove leads from timer contact terminals. Measure resistance of following terminals: 1 to 2—Timer in OFF position..... 1 to 2—Timer in ON position..... 3 to 4—Timer in OFF or ON position	If timer does not indicate readings below, replace timer. Infinite Ω Approximately <1 Ω Approximately 11 KΩ (timer motor)

Testing Procedures



WARNING

To avoid risk of electrical shock, personal injury or death; disconnect power to oven and discharge capacitor before servicing, unless testing requires power.

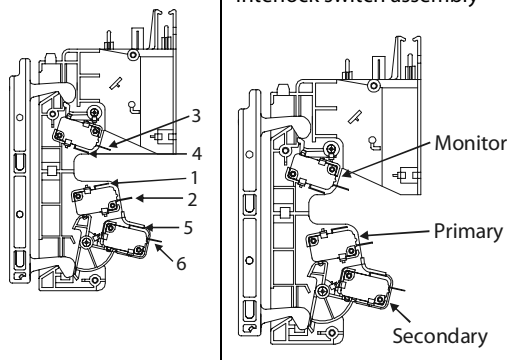
Illustration	Component	Testing	Results
	Interlock switch assembly	<p>Disconnect wires to switch.</p> <p>With door open measure resistance from: Monitor - Terminal 3 - 4..... Primary - Terminal 1 - 2 Secondary - Terminal 5 - 6</p> <p>With door closed measure resistance from: Monitor - Terminal 3 - 4..... Primary - Terminal 1 - 2 Secondary - Terminal 5 - 6</p> <p>After verifying or replacing the module, reconnect wires to switch and check operation of monitor circuit before operating the oven.</p>	<p>Indicates continuity</p> <p>Infinite Ω</p> <p>Infinite Ω</p> <p>Infinite Ω</p> <p>Indicates continuity</p> <p>Indicates continuity</p>
	Lamp receptacle	Test continuity of receptacle terminals.	Indicates continuity with bulb installed.
	Wire Harness	Test continuity of wires	Indicates continuity

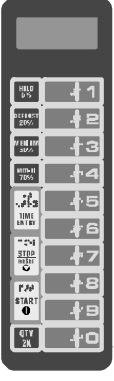
Electronic Control Panel			
	Service Test Mode:	<p>Open door, Press and Hold pad 3 for 5 seconds to enter service test mode.</p> <p>Press Pad 1</p> <p>Press Pad 2</p> <p>Press Pad 3</p> <p>Press Pad 4</p> <p>Press Pad 5</p> <p>Press Pad 6</p> <p>Press Pad 7</p> <p>Press Pad 8</p> <p>Press Pad 9</p> <p>Press Pad 0</p> <p>Stop/Reset Pad</p>	<p>SERVICE appears in the display</p> <p>Indicates number of hours magnetron has been turned on</p> <p>Indicates number of times magnetron tube has been turned on and off</p> <p>Indicates number of door cycles CLEAR (Press START pad to reset service data.)</p> <p>Indicates amperage</p> <p>N/A</p> <p>RESET (Clear Service Alarm)</p> <p>N/A</p> <p>N/A</p> <p>N/A</p> <p>Exit Service Test Mode</p>
	Error codes:	<p>E-08</p> <p>E-09</p> <p>E-10</p>	<p>Replace Control Board</p> <p>Replace Control Board</p> <p>Shorted or Open Keypad – Test and replace if necessary</p>

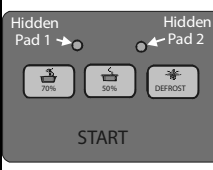
Electronic Dial Control Panel			
	Service Test Mode:	<p>Open door, Press and Hold Hidden Pad 2 for 5 seconds to enter service test mode.</p> <p>Press Hidden Pad 2</p> <p>Press Hidden Pad 2 again</p> <p>Press Hidden Pad 2 again</p> <p>Press Hidden Pad 2 again</p> <p>Press Hidden Pad 2 again</p> <p>Press Hidden Pad 2 again</p>	<p>Enters into Service Test Mode</p> <p>Indicates number of magnetron hours</p> <p>Indicates tube cycles</p> <p>Indicates number of door cycles</p> <p>Indicates amperage</p> <p>Turn dial to Clear Info – When dial is rotated display indicates CLEARED INFO</p>

Testing Procedures



WARNING

To avoid risk of electrical shock, personal injury or death; disconnect power to oven and discharge capacitor before servicing, unless testing requires power.

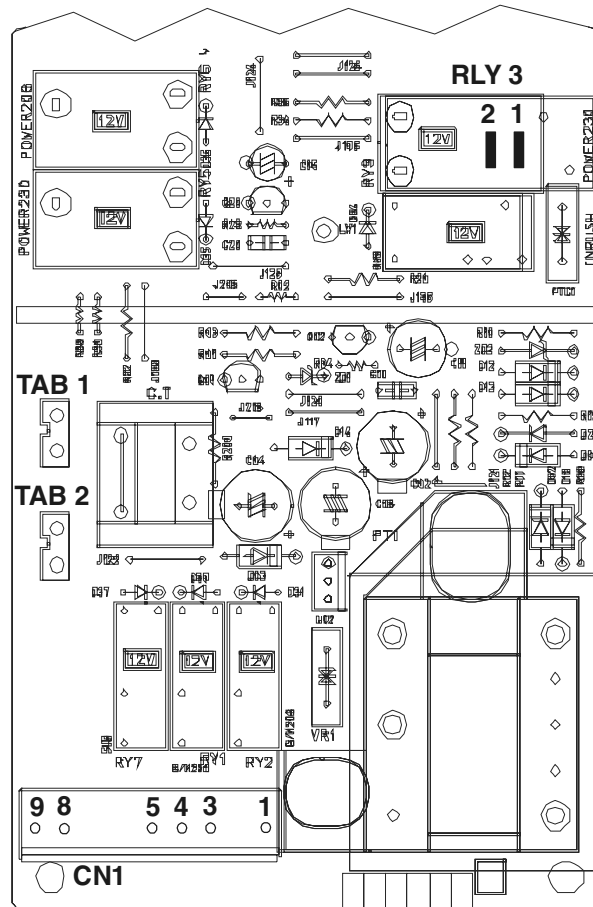

Function	Test Set-Up / Condition	Meter Setting	Probe Placement	Results
Power to current transformer	All Conditions	Volts	Tab 1 to CN1 Pin 3 (Neutral)	120 VAC
Power from current transformer	All Conditions	Volts	Tab 2 to CN1 Pin 3 (Neutral)	120 VAC
Power from Oven TCO	All Conditions	Volts	CN1 – Pin 1 (Black wire to Neutral)	120 VAC
Power to Oven Light	Standby	Volts	CN1 – Pin 4 to Pin 1	120 VAC
	Ready	Volts	CN1 – Pin 4 to Pin 1	0 VAC
	Cook	Volts	CN1 – Pin 4 to Pin 1	0 VAC
Power to Blower Motor	Standby	Volts	CN1 – Pin 5 to Pin 1	120 VAC
	Ready	Volts	CN1 – Pin 5 to Pin 1	0 VAC
	Cook	Volts	CN1 – Pin 5 to Pin 1	0 VAC
Secondary Interlock Switch	Door Closed	Ohms	CN1 – Pin 8 to Pin 9	Continuity
	Door Opened	Ohms	CN1 – Pin 8 to Pin 9	Infinite
Power to Relay 3	Standby	Volts	Relay 3 – Pin 1 to Pin 2	120 VAC
	Ready	Volts	Relay 3 – Pin 1 to Pin 2	120 VAC
	Cook	Volts	Relay 3 – Pin 1 to Pin 2	0 VAC

Testing Procedures



WARNING

To avoid risk of electrical shock, personal injury or death; disconnect power to oven and discharge capacitor before servicing, unless testing requires power.

Power Test

All ACP microwave oven power outputs are rated using the IEC705 standards. Using the IEC705 test method requires precision measurements and equipment that is not practical to be performed in the field. Using the test shown below will indicate if the oven performance is satisfactory.

Test equipment required:

- 1000 ml test container and thermometer.
- Digital watch / watch with a second hand for use on ovens with electromechanical timers.

Important Notes:

- Low line voltage will cause low temperature rise / power output.
- Ovens must be on a dedicated circuit, properly grounded, and polarized. Other equipment on the same circuit may cause a low temperature rise / power output.
- This test and results are not a true IEC705 test procedures and are only intended to provide servicers with an easy means of determining if the microwave oven cooking output is correct.

Procedure

1. Fill the test container to the 1000 ml line with cool tap water.

NOTE: Water temperature should be approximately 60°F / 16°C

2. Using the thermometer, stir water for five to ten seconds; measure, and record the temperature (T1).
3. Place test container of water in the center of oven cavity and close door.
4. Heat the water for a 33-second full power cycle.

NOTE: Use a digital watch or a watch with a second hand for ovens with electromechanical timers.

1. At end of the cycle, remove test container. Using the thermometer, stir water for five to ten seconds and record temperature .
2. Subtract the starting water temperature , from the ending water temperature to obtain the temperature rise .
3. If the temperature rise meets or exceeds the minimum, the test is complete. If the temperature rise fails to meet the minimum temperature rise, test the line voltage to verify it is correct. Then repeat steps 1-6 making sure to change the water. If the temperature rise fails to meet the minimum temperature rise again the oven will require service.

Minimum Temperature Rise at Thirty -Three (33) Seconds Run Time

Cooking (°F) Power Output		Cooking (°F) Power Output		Cooking (°C) Power Output		Cooking (°C) Power Output	
10.....	1000	20.....	2000	5	1000	11.....	2000
11.....	1100	21.....	2100	5.5	1100	11.5.....	2100
12.....	1200	22.....	2200	6.5	1200	12.....	2200
14.....	1400	24.....	2400	7.5	1400	13.....	2400
17.....	1700	25.....	2500	9.5	1700	13.5.....	2500
18.....	1800	27.....	2700	10	1800	15.....	2700
19.....	1900	30.....	3000	10.5	1900	16.5.....	3000

Disassembly Procedures

WARNING

To avoid the risk of electrical shock, personal injury, or death, disconnect power to oven and discharge the capacitors before following any disassembly procedure.

High voltage is present at the high voltage terminal of the high voltage transformer during any cooking cycle.

It is neither necessary or advisable to attempt measurement of the high voltage.

Before touching any oven components or wiring, always unplug the oven from its power source and discharge capacitor.

Disconnecting Wire Terminals

All wire terminals are locking-type terminals. Proceed as follows to disconnect wire terminals:

Insulated terminals:

Grasp insulator pod and pull back.

DO NOT PULL ON WIRE.

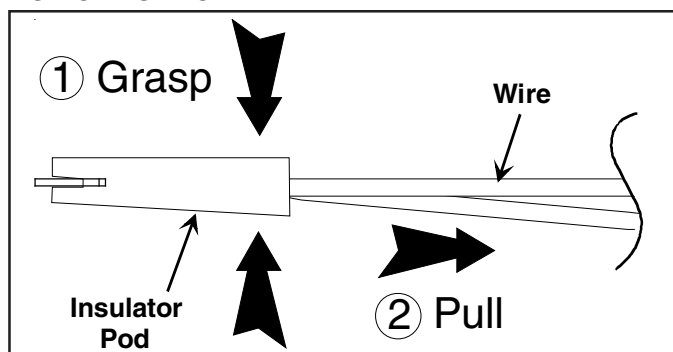

Non-insulated terminals:

Use a small blade screwdriver to depress locking-tab and pull on terminal.

DO NOT PULL ON WIRE.

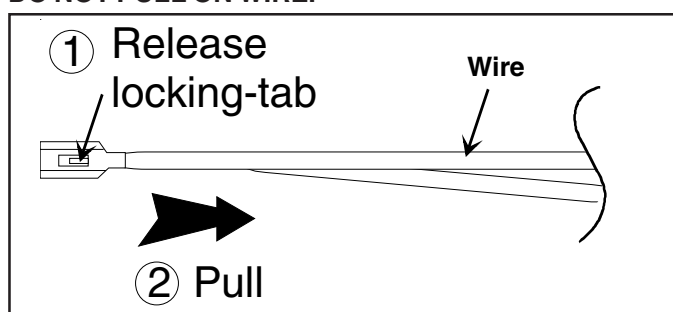

Outer Case

1. Disconnect power to oven.
2. Remove screws securing outer case to unit.
3. Slide outer case towards rear of unit.
4. Reverse procedure to reassemble.

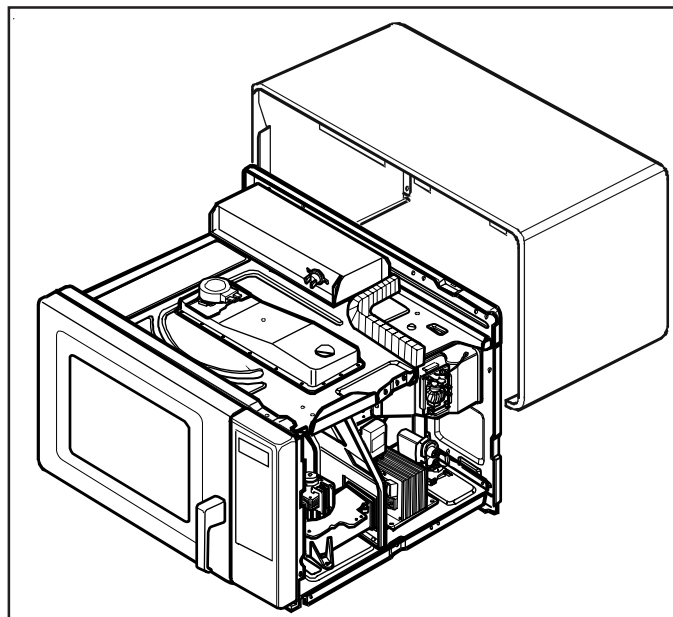

CAUTION

During disassembly some foam gaskets may require removal. These components must be replaced for proper circulation of air over the components and through the oven cavity.

Disassembly Procedures



WARNING

To avoid the risk of electrical shock, personal injury, or death, disconnect power to oven and discharge the capacitors before following any disassembly procedure.

Door Assembly



CAUTION

A microwave leakage test must be performed anytime a door assembly is removed, replaced, disassembled, or adjusted for any reason.

Door Removal

1. Disconnect power to oven.
2. Open oven door, remove top hinge cap, and slowly lift door to disengage the hinge pins at top and bottom.

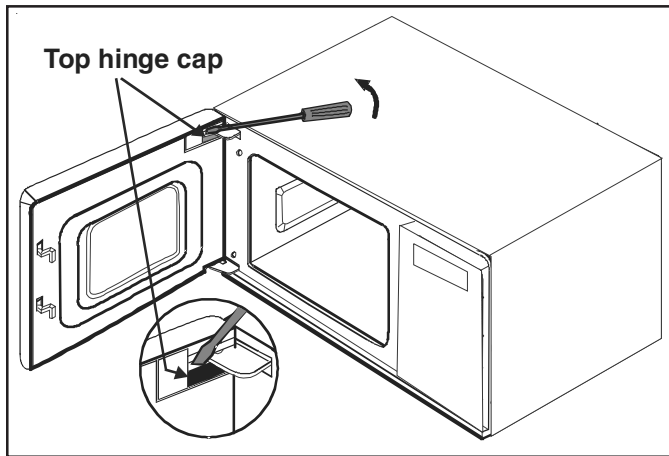

3. To reinstall door, place top pin into slot first, then align bottom pin.
4. Reinstall top hinge cap.

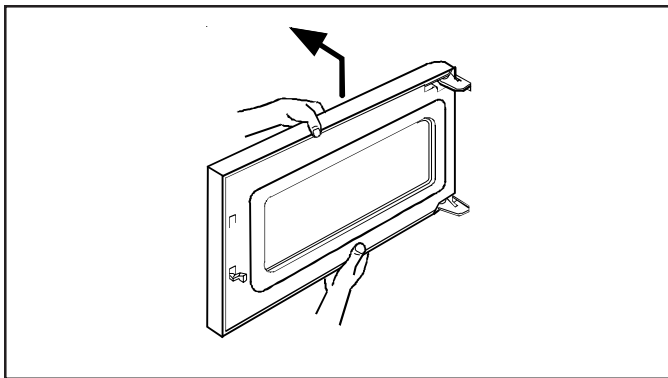

Door Disassembly

1. Disconnect power to oven.
2. Remove oven door, (see "Door Removal").
3. Begin at the bottom of the door near hinge, insert flat blade screwdriver between choke cover and outer door panel. Gently pry upward on choke cover to release tabs. Work in clockwise direction to remove choke cover.



CAUTION

To avoid property damage, care must be taken when prying choke cover from oven door.

4. Remove screw securing door handle to latch assembly.
5. Slide latch assembly downward and pull away from door frame to release.
6. Remove screws securing choke assembly to outer door panel.

NOTE: When disassembling door, use caution to prevent deformation of slats on door frame/choke assembly.

7. Begin at hinge side of door near bottom, insert flat blade screwdriver between door frame/choke assembly and outer door panel. Gently pry outer door panel away from door frame to release tabs. Work in clockwise direction to remove door frame.
8. Remove spring from hinge assembly.
9. Remove screws securing hinge assembly to choke assembly.
10. Reassemble in reverse order.

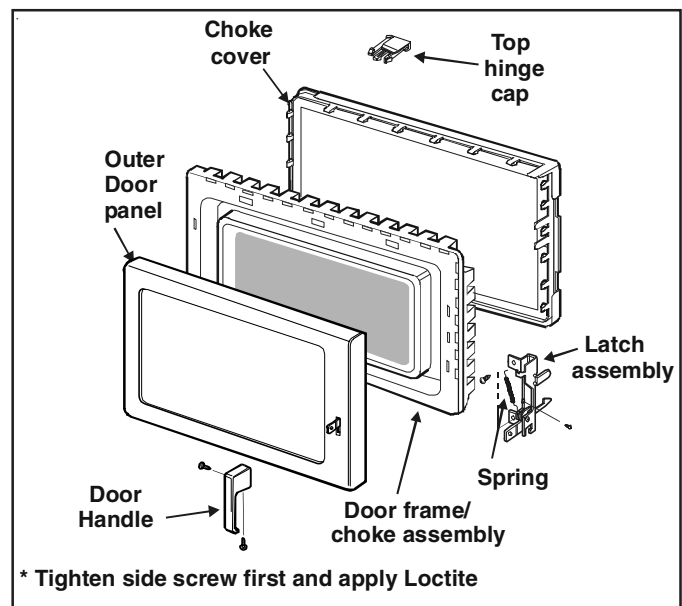

Disassembly Procedures

WARNING

To avoid the risk of electrical shock, personal injury, or death, disconnect power to oven and discharge the capacitors before following any disassembly procedure.

CAUTION

A microwave leakage test must be performed anytime a door assembly is removed, replaced, disassembly, or adjusted for any reason.

Control Panel Removal

1. Disconnect power to oven and remove outer case, (see "Outer Case" procedure).
2. Disconnect and label wires from controller/timer.
3. Open oven door.
4. Remove screw securing top of control panel to cavity. Lift control panel up and out to release tabs.

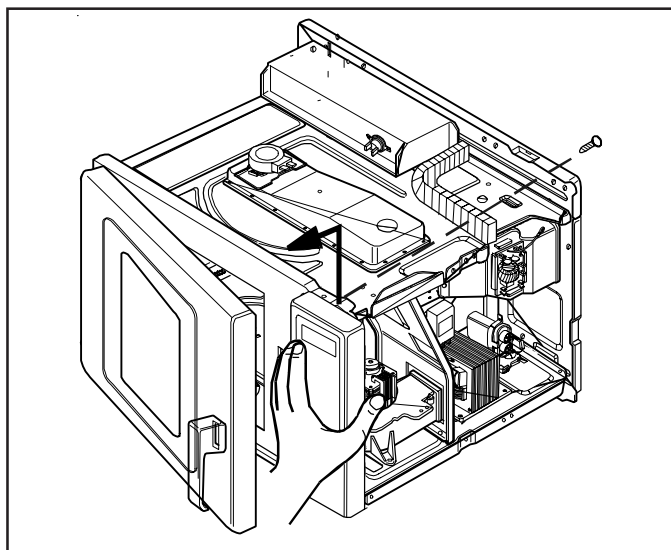

5. Replace component and reverse procedure to reassemble.

Interlock Switches

Primary switch is operated by bottom latch arm.

Interlock Switch Removal

1. Disconnect power to oven and remove outer case, (see "Outer Case" procedure).
2. Remove control panel, (see "Control Panel" section).
3. Test interlock switches before removing, (see testing procedures).
4. Disconnect and label wire connections.
5. Remove mounting screws securing interlock switch to unit chassis.
6. Remove switches by carefully releasing locking tabs on switch bracket and tilting switches to remove from switch bracket.

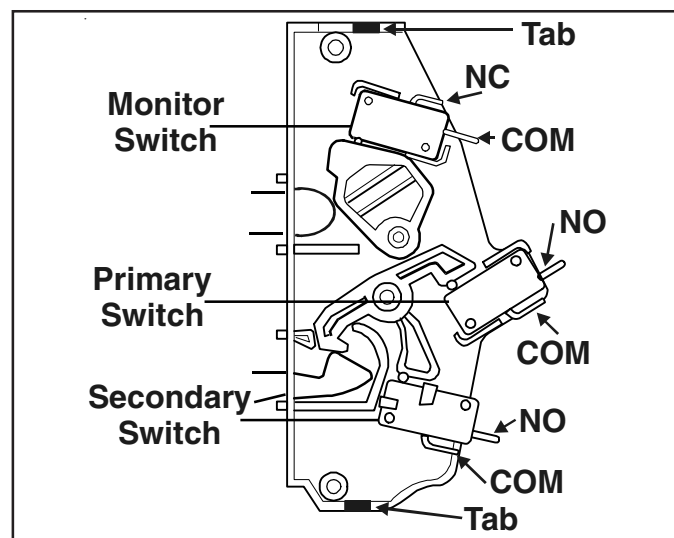

NOTE: After repairing the door or the interlock system, it is necessary to check the switch continuity before operating the oven.

CAUTION

Before replacing a blown monitor fuse, test the primary interlock switch, secondary interlock switch, monitor switch, and power relay contacts for proper operation. If the monitor fuse is blown by a failed switch operation, all switches and controller must be

Disassembly Procedures



WARNING

To avoid the risk of electrical shock, personal injury, or death, disconnect power to oven and discharge the capacitors before following any disassembly procedure.

Adjusting Interlocks

The interlock monitor, primary, and secondary switches act as a final safety switch, protecting the operator from microwave energy. After adjusting the interlock switch assembly, verify wires are correctly connected.

For door fit and switch operation, switch bracket is adjustable.

1. Disconnect power to oven and remove outer case, (see "Outer Case" procedure).
2. Loosen switch bracket mounting screws.
3. Close oven door, move switch bracket toward rear of oven until door gap is less than $\frac{1}{64}$ -inch (0.5 mm).
4. Hold switch bracket securely for proper switch operation and door fit, retighten screws.
5. Open oven door slowly, watching the switches. Verify switches release in the following order.
 - Primary interlock switch
 - Secondary interlock switch
 - Interlock monitor switch

NOTE: Adjust the switch bracket until all switches operate in proper sequence.

6. Close the oven door slowly, watching the switches. Verify switches activate in the following order.
 - Interlock monitor switch
 - Secondary interlock switch
 - Primary interlock switch
7. When proper switch sequence has been achieved, tighten the switch bracket securely.



CAUTION

A microwave leakage test must be performed anytime a door assembly is removed, replaced, disassembled,

High Voltage Capacitor

High voltage capacitor should always be discharged by shorting a terminal to a chassis ground. The capacitor has a internal "shunt" resistor, but the mechanical discharge should always be performed to avoid personal injury.

High Voltage Capacitor Removal

1. Disconnect power to oven and remove outer case, (see "Outer Case" procedure).
2. Discharge high voltage capacitor.
3. Remove and label wire leads from capacitor terminals.
4. Remove screw securing capacitor strap to bottom plate.
5. Slide capacitor out of capacitor strap and remove capacitor.
6. Replace capacitor and reverse procedure to reassemble.

NOTE: When replacing H.V. components, route H.V. wires at least $\frac{1}{4}$ " / 6 mm from all grounded surfaces to prevent arcing.

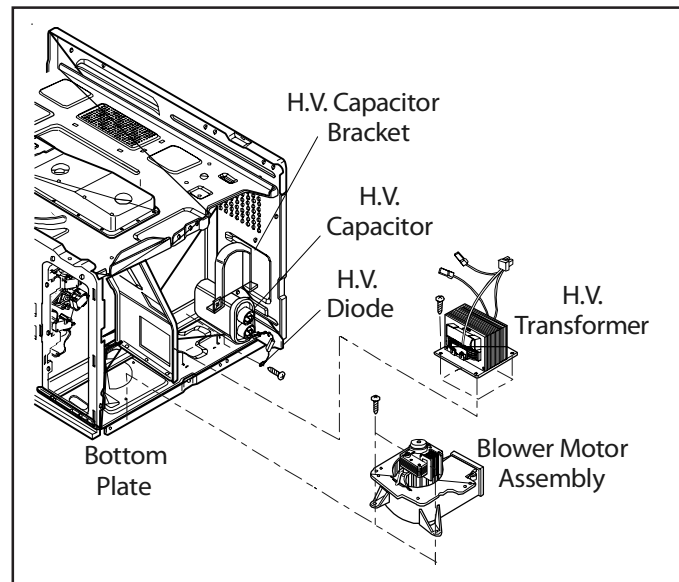

Diode

1. Disconnect power to oven and remove outer case, (see "Outer Case" procedure).
2. Discharge high voltage capacitor, (see "High Voltage Capacitor" section).
3. Disconnect diode from high voltage capacitor and remove screw securing diode to ground.

Disassembly Procedures

WARNING

To avoid the risk of electrical shock, personal injury, or death, disconnect power to oven and discharge the capacitors before following any disassembly procedure.

Transformer

1. Disconnect power to oven and remove outer case, (see "Outer Case" procedure).
2. Discharge high voltage capacitor, (see "High Voltage Capacitor" section).
3. Disconnect and label wire leads from transformer.
4. Remove screws securing transformer and remove.
5. Replace transformer and reverse procedure to reassemble.

Fuse / Fuse Block / Filter Assembly

1. Disconnect power to oven and remove outer case, (see "Outer Case" section).
2. Disconnect and label wires.
3. Remove fuses to gain access to screws securing assembly.
4. Carefully lift tab to release assembly from locating pin.
5. Replace component(s) and reverse procedure to reassemble.

CAUTION

Before replacing a blown monitor fuse, test the primary interlock switch, secondary interlock switch, monitor switch, and power relay contacts for proper operation. If the monitor fuse is blown by a failed switch operation, all switches and controller must be

Magnetron

Magnetron is located on the side of the cavity.

1. Disconnect power to oven and remove outer case, (see "Outer Case" section).
2. Discharge high voltage capacitor, (see "High Voltage Capacitor" section).
3. Remove terminal plug from filament terminals.
4. Remove screws securing magnetron cutout bracket to magnetron.
5. Remove screws securing magnetron to the wave guide.

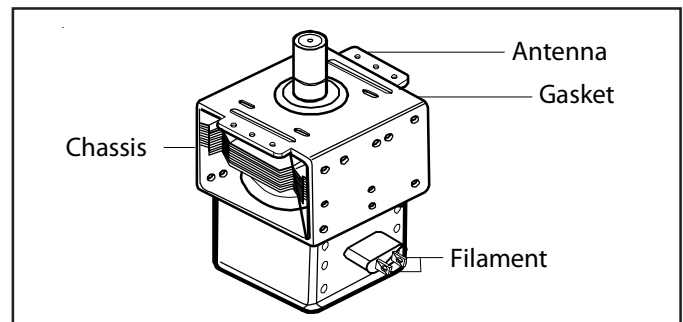

6. Replace magnetron and reverse procedure to reassemble.

NOTE: When replacing magnetron, make sure gasket is in correct position and in good condition.

CAUTION

During replacement of magnetron, be certain the R.F. anode gasket is in place around the anode stud.

WARNING

A microwave leakage test must be performed anytime a magnetron assembly is removed, replaced, disassembled, or adjusted for any reason.

Disassembly Procedures



WARNING

To avoid the risk of electrical shock, personal injury, or death, disconnect power to oven and discharge the capacitors before following any disassembly procedure.

Blower Motor or Wheel

1. Disconnect power to oven and remove outer case, (see "Outer Case" procedure).
2. Remove outer case.
3. Disconnect wiring from blower motor.
4. Remove screws securing scroll to chassis.
5. Slide scroll discharge snout from partition and lift scroll assembly from unit.
6. Replace component and reverse procedure to reassemble.

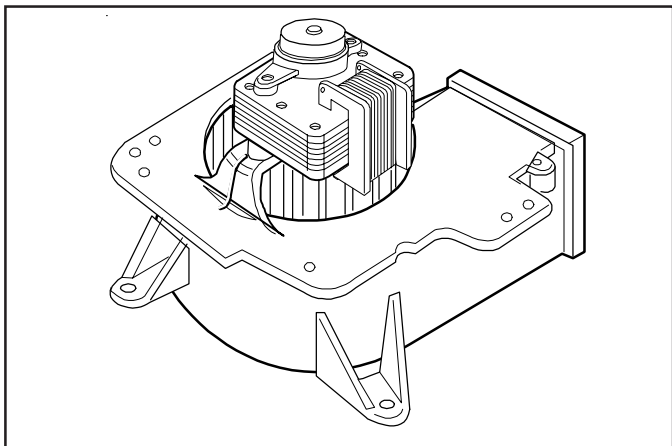

Splatter Shield

NOTE: Be careful not to bend antenna when removing splatter shield. Shield snaps into a lip in front of the oven and three slots in the back.

1. Place your thumbs in the two indentations in front of the shield.
2. Press lightly towards the back and carefully lower shield away from antenna.
3. Pull shield out of the back slots and out of the oven.

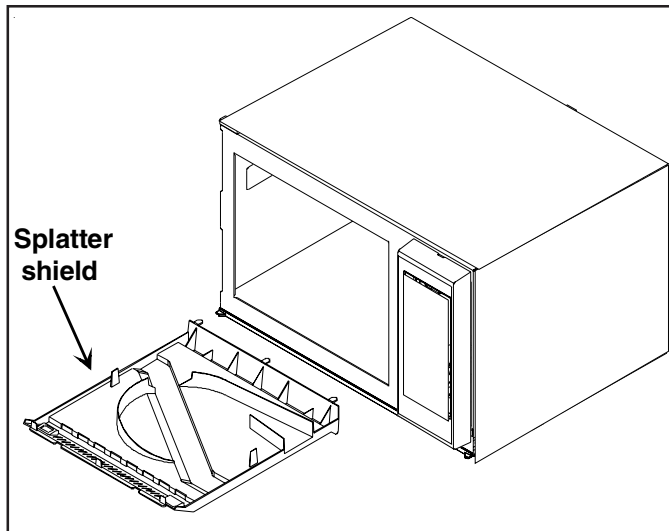

Antenna

1. Remove splatter shield from oven cavity.
2. Remove two mounting rivets on the top of oven cavity to remove cradle. Support cradle before removing mounting rivets to avoid damage to antenna assembly.

Stirrer Motor

1. Disconnect power to oven and remove outer case, (see "Outer Case" procedure).
2. Remove outer case.
3. Disconnect wire terminals from stirrer motor.
4. Remove screws securing stirrer motor to wave guide.
5. Replace component and reverse procedure to reassemble.

NOTE: When replacing stirrer motor, verify motor shaft is aligned with antenna shaft before securing with screws.

Disassembly Procedures



WARNING

To avoid the risk of electrical shock, personal injury, or death, disconnect power to oven and discharge the capacitors before following any disassembly procedure.

Magnetron Thermal Cut-Out (TCO)

1. Disconnect power to oven and remove outer case, (see "Outer Case" procedure).
2. Remove outer case.
3. Remove TCO by removing screws.
4. Disconnect wiring.
5. Replace component and reverse procedure to reassemble.

NOTE: When reconnecting wiring to thermal fuses the connectors must be tight.

Cavity Thermal Fuse

1. Disconnect power to oven and remove outer case, (see "Outer Case" procedure).
2. Remove outer case.
3. Remove thermal fuse mounting screw.
4. Disconnect wiring.
5. Replace component and reverse procedure to reassemble.

NOTE: When reconnecting wiring to thermal fuses the connectors must be tight.

Tray Replacement

1. Unplug oven from outlet.
2. Using a suction cup to pry upward on front portion and remove tray from unit.
3. Thoroughly clean and degrease sump area.
4. Clean oven cavity bottom where new oven tray will make contact using mineral spirits or any non-flammable degreasing solvent.

NOTE: Detergents, soap, and water are not sufficient to remove oil and grease.

5. Place new tray into unit and clean cavity with mild detergent to remove any remaining degreasing solvent.

Oven Light Removal

The light bulb for inside of the oven can be changed only from the side of the unit. On the left hand side of the oven is a metal plate with one screw. The light bulb is located behind this plate.

Follow these steps to change the bulb:

1. Disconnect power to oven and remove outer case, (see "Outer Case" procedure).
2. Remove screw and plate from side of unit.
3. To remove bulb, turn it counterclockwise, being careful not to burn fingers or break the bulb.
4. Replace bulb with a 40 watt, 115 - 125 volt appliance bulb.
5. Reposition plate, being careful not to bend hinge tab. Replace and tighten screw. Do not operate oven without plate in place.

Appendix A

Quick Start Reference Guide

Refer to Product Safety Manual for Safety Statements

Complete Owner's Manual available online

The switching operation of this microwave oven can cause voltage fluctuations on the supply line. The operation of this oven under unfavorable voltage supply conditions can have adverse effects. This device is intended for the connection to a power supply system with a maximum permissible system impedance Z_{max} of 0.2 Ohms at the interface point of the user's supply. The user has to ensure that this device is connected only to a power supply system which fulfills the requirement above. If necessary, the user can ask the public power supply company for the system impedance at the interface point.

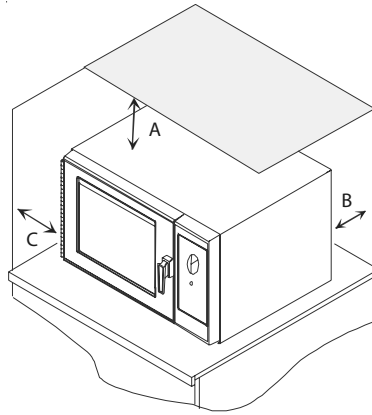

Oven Wall Clearances

- A—For North American (UL/CSA) models, allow at least 2" (5.1 cm) of clearance around top of oven. For International (50 Hz) models, allow at least 12" (30 cm) of clearance around top of oven. Proper air flow around oven cools electrical components. With restricted air flow, oven may not operate properly and life of electrical parts is reduced.
- B—Allow at least 2" (5.1 cm) between air discharge on back of oven and back wall.
- C—Allow at least 2" (5.1 cm) of clearance around sides of oven.

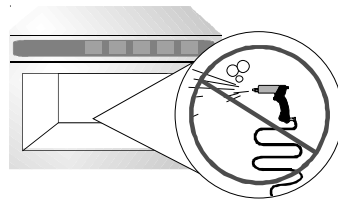

DO NOT power spray

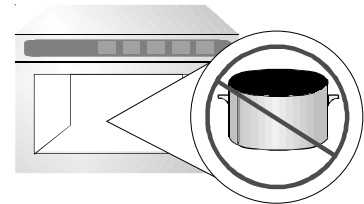

No metal pans

HEATING GUIDE		
ITEM	TIME SETTING	DIAL LETTER
ROLL, PASTRY.....	15 SEC.	A
HOT DOG	30 SEC.	B
HAMBURGER, SUB		
BURRITO, PIZZA.....	1 MIN.	D
CHILI, SOUP,		
STEW	1-2 MIN.	F
POPCORN	2 MIN.	H

So...how do I use it? (Mechanical Dial)

Heating

1. Open oven door, place food in oven, and close oven door.
2. Turn time entry knob clockwise to desired time.
 - Cooking time can be set up to 6 minutes.
 - Oven begins operation and time counts down.
3. When cooking time has elapsed, microwave energy stops and oven signal sounds.

Interrupting Operation

Open oven door to interrupt operation or turn time entry knob counterclockwise to "0".

To resume microwave oven operation, close door and turn knob.

Changing Time and Canceling Mistakes

Heating time can be changed at any time while the oven is operating. Turn knob to desired new setting. To set cooking time to zero, turn knob counterclockwise to "0".

So...how do I use it? (Digital Dial)

Heating

- Open oven door, place food in oven, and close oven door.
- Turn time entry knob clockwise until desired time displays.
 - Factory default setting for cooking time is 10 minutes. Cooking time can be changed and set to 60 minutes. (Refer to section on changing options)
- Press a power level pad to change power level, if desired. If no power level is selected, unit will default to 100%.
 - Power level can be set from full power (100%), to 70%, 50% or DEFROST (20%).
- Press **START** button.
 - Oven begins operation and time counts down.
- When cooking time has elapsed, microwave energy stops and oven signal sounds.

Interrupting Operation

Open oven door to interrupt operation or turn time entry knob counterclockwise to "0".

To resume microwave oven operation, close door and press **START**.

If time was changed to "0", time will need to be reset, and then press **START**.

Changing Time and Power/Canceling Mistakes

Heating time and power level can be changed at any time while the oven is operating. Turn knob to desired new setting. To set cooking time to zero, turn knob counterclockwise to "0".



Part No.12804404
Revised 5/10

©2010 ACP, Inc.

:30 QUICK SET :30 QUICK SET Pad

Allows you to reheat for 30 seconds at 100% (full) power by simply pressing the :30 QUICK SET pad. By repeatedly pressing this pad, you can extend the reheating time to 5 minutes by 30 second increments. To change the time assigned to this pad:

- Open oven door.
 - If door is closed before programming is complete, changes are discarded.
- Press and hold the :30 QUICK SET pad for approximately 5 seconds.
 - This activates the programming mode.
 - Microwave will beep and either current or assigned time will show in display.
- Turn Dial to change time setting.
 - Time can be set from zero (0:00) seconds to five minutes (5:00).
 - If the assigned time is 0:00, the :30 QUICK SET pad is effectively disabled.
- Press **START** pad to save changes.



Can I change an option?

Options can be changed to suit individual preferences.

To change options:

- Open oven door.
 - If door is closed before programming is complete, changes are discarded and microwave exits options programming mode.
- Press and hold the Hidden Pad for approximately 5 seconds.
 - This begins options programming mode.
 - Microwave will beep and **OP:--** appears in display.
- Press the Hidden Pad to advance to the desired option to be changed.
 - See table below for options.
- Turn Dial to change option setting.
 - OP:** and option number appear in display.
 - See table below for options.
- Press **START** pad to save changes.
 - To change additional options, repeat steps 2 - 5.
 - Changes appear after door is closed.

Numbered Pads	Display	Options (Factory Settings in Bold)
1	OP:10	3 second continuous beep.
End of Cycle Beep	OP:11	Continuous beep until door is opened.
	OP:12	5 beep bursts until door is opened.
	OP:20	Eliminates beep.
2	OP:21	Sets volume to low.
	OP:22	Sets volume to medium.
	OP:23	Sets volume to high.
	OP:30	Prevents beep when pad is pressed.
3	OP:31	Allows beep when pad is pressed.
	OP:40	15 seconds after oven door is opened, keyboard disabled.
4	OP:41	30 seconds after oven door is opened, keyboard disabled.
	OP:42	1 minute after oven door is opened, keyboard disabled.
	OP:43	2 minutes after oven door is opened, keyboard disabled.
	OP:50	Prevents adding heating time while oven is heating.
5	OP:51	Allows heating time to be changed while oven is heating when a memory pad is pressed.
	OP:60	Allows oven to resume heating time countdown after door is opened during cycle.
6	OP:61	Cancels heating time count down after door is opened during cycle.
	OP:70	Allows 60 minutes of heating time.
7 (some models)	OP:71	Allows 10 minutes of heating time.
	OP:00	Do not display message.
0	OP:01	Display message for 24 hours every 7 days.
	OP:02	Display message for 24 hours every 30 days.
	OP:03	Display message for 24 hours every 90 days.

For full product documentation visit:

www.acpsolutions.com

16023293 Rev. 0

2010 ACP, Inc.
Cedar Rapids, Iowa 52404

Amana MENUMASTER CLEAN FILTER

This oven displays CLEAN FILTER at user defined intervals. When the message displays ACP recommends cleaning the air filter thoroughly. Cleaning the air filter will not shut off the message. The message will stop displaying automatically after 24 hours. Depending on microwave use and environmental conditions, the filter may need to be cleaned more frequently. Once the frequency is determined, set the option for the appropriate time frame.

7 Preprogrammed Pads

To cook food using preprogrammed cooking sequences:

1. Open oven door and place food in oven. Close door.
2. Press desired pad.
3. Oven begins to cook.
4. At end of cooking cycle oven beeps and shuts off.

QTY 2X Programming (some models)

To change the cooking factor:

1. Open oven door.
2. Press and hold pad 1 for approximately 5 seconds.
3. Press pad to be reprogrammed.
4. Press the QTY 2X pad.
5. Press a numbered pad to change the cooking factor.
 - Cooking factor can be set from 10% to 100%.
 - Default is 80%.
 - Pad 5 would change the cooking factor to 50%.
6. Press START pad to save changes.

Quick Start Reference Guide

Refer to Product Safety Manual for Safety Statements

Complete Owner's Manual available online

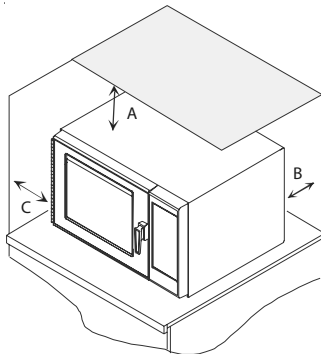

Oven Wall Clearances

- A—For North American (UL/CSA) models, allow at least 2" (5.1 cm) of clearance around top of oven. For International (50 Hz) models, allow at least 12" (30 cm) of clearance around top of oven. Proper air flow around oven cools electrical components. With restricted air flow, oven may not operate properly and life of electrical parts is reduced.
- B—Allow at least 2" (5.1 cm) between air discharge on back of oven and back wall.
- C—Allow at least 2" (5.1 cm) of clearance around sides of oven.

So...how do I use it? (Electronic Control)

Manual Operation

To cook food using a specific entered time and power level:

1. Open oven door and place food in oven. Close door.
2. Press TIME ENTRY pad and enter cooking time.
3. Press a power level pad to change power level if desired (some models).
 - COOK LEVEL displays with the power setting.
4. If stage cooking is desired, press TIME ENTRY pad and repeat steps 2 through 4, (some models).
5. Press START pad.
6. At end of cooking cycle oven beeps and shuts off.

Programming Items

1. Open oven door.
2. Press and hold pad 1 for approximately 5 seconds.
3. Press pad to be reprogrammed.
4. Enter cooking time by using the number pads.
5. Press a power level pad to change power level if desired.
6. If stage cooking is desired, press TIME ENTRY pad.
 - Display briefly shows the stage number.
 - Display changes to cook time and power level for the next stage.
7. Enter cook time and power level as in steps 4 and 5 (some models).
 - To enter another cooking stage for that pad, press TIME ENTRY pad again.
 - Up to four different stages can be programmed (some models).
8. Press START pad to set new programming changes to the pad.

NOTE: To discard changes, press STOP/RESET pad or close oven door.

QTY 2X Pad (some models)

1. Open oven door and place food in oven. Close door.
2. Press QTY 2X pad.
3. Press desired preprogrammed pad or pad sequence.
4. Oven begins cooking. Displayed cooking time is the total of original cooking time and added 2X time.

The switching operation of this microwave oven can cause voltage fluctuations on the supply line. The operation of this oven under unfavorable voltage supply conditions can have adverse effects. This device is intended for the connection to a power supply system with a maximum permissible system impedance Z_{max} of 0.2 Ohms at the interface point of the user's supply. The user has to ensure that this device is connected only to a power supply system which fulfills the requirement above. If necessary, the user can ask the public power supply company for the system impedance at the interface point.

Quick Start Reference Guide

Refer to Product Safety Manual for Safety Statements

Complete Owner's Manual available online

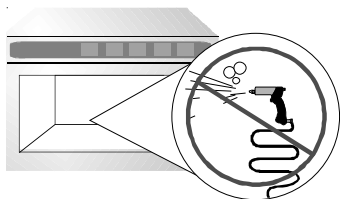

DO NOT power spray

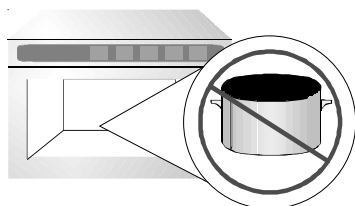

No metal pans

? Can I change an option?

Options such as single or double pad programming, beep volume, and maximum cooking time can be changed to suit individual preferences.

To change options:

1. Open oven door.
 - If door is closed or RESET pad is pressed before programming is complete, changes are discarded and microwave exits programming mode.
2. Press and hold pad 2 for approximately 5 seconds.
 - This begins options mode.
 - Microwave will beep and OP: displays.
3. Press number pad that controls option to be changed.
 - See table below for options.
 - Current option will display.
4. Press number pad again to change the option.
 - Each time pad is pressed, option will change.
 - Match code displayed with code for desired option.
5. Press START pad to save changes.
 - To change additional options, repeat steps 3 and 4.
 - Changes appear after door is closed or STOP/RESET pad is pressed.

Numbered Pads	Display	Options (Factory Settings in Bold)
1 End of Cycle Beep	OP:10	3 second beep.
	OP:11	Continuous beep until door is opened.
	OP:12	5 beep bursts until door is opened.
2 Speaker Volume	OP:20	Eliminates beep.
	OP:21	Sets volume to low.
	OP:22	Sets volume to medium.
	OP:23	Sets volume to high.
3 Key Beep	OP:30	Prevents beep when pad is pressed.
	OP:31	Allows beep when pad is pressed.
4 Keyboard Enable Window	OP:40	15 seconds after oven door is opened, keyboard disabled.
	OP:41	30 seconds after oven door is opened, keyboard disabled.
	OP:42	1 minute after oven door is opened, keyboard disabled.
	OP:43	2 minutes after oven door is opened, keyboard disabled.
5 Add Time During Heating	OP:50	Prevents adding heating time while oven is heating.
	OP:51	Allows heating time to be changed while oven is heating when a memory pad is pressed.
6 Reset Door Open	OP:60	Allows oven to resume heating time countdown after door is opened during cycle.
	OP:61	Cancels heating time count down after door is opened during cycle.
7 (some models) Maximum Heating Time	OP:70	Allows 60 minutes of heating time (some models).
	OP:71	Allows 10 minutes of heating time.
8 Manual Operation	OP:80	Allows use of preprogrammed pads only.
	OP:81	Allows use of manual time entry and preprogrammed pads.
9 (some models) Double Digit Operation	OP:90	Allows 10 (0-9) preprogrammed pads.
	OP:91	Allows 100 (00-99) preprogrammed pads.
0 Clean Filter Message	OP:00	Do not display message.
	OP:01	Display message for 24 hours every 7 days.
	OP:02	Display message for 24 hours every 30 days.
	OP:03	Display message for 24 hours every 90 days.