

# Repair Parts List

MODEL NUMBER

RC5MDTM2

MANUFACTURING  
NUMBER

P1332836M

## COMMERCIAL MICROWAVE

When requesting service or ordering parts, always provide the following information:

- Product Type
- Part Number
- Model Number
- Part Description



Section: TRAY, GREASE SHIELD, CABINET,

Model: RC5MDTM2\_P1332836M

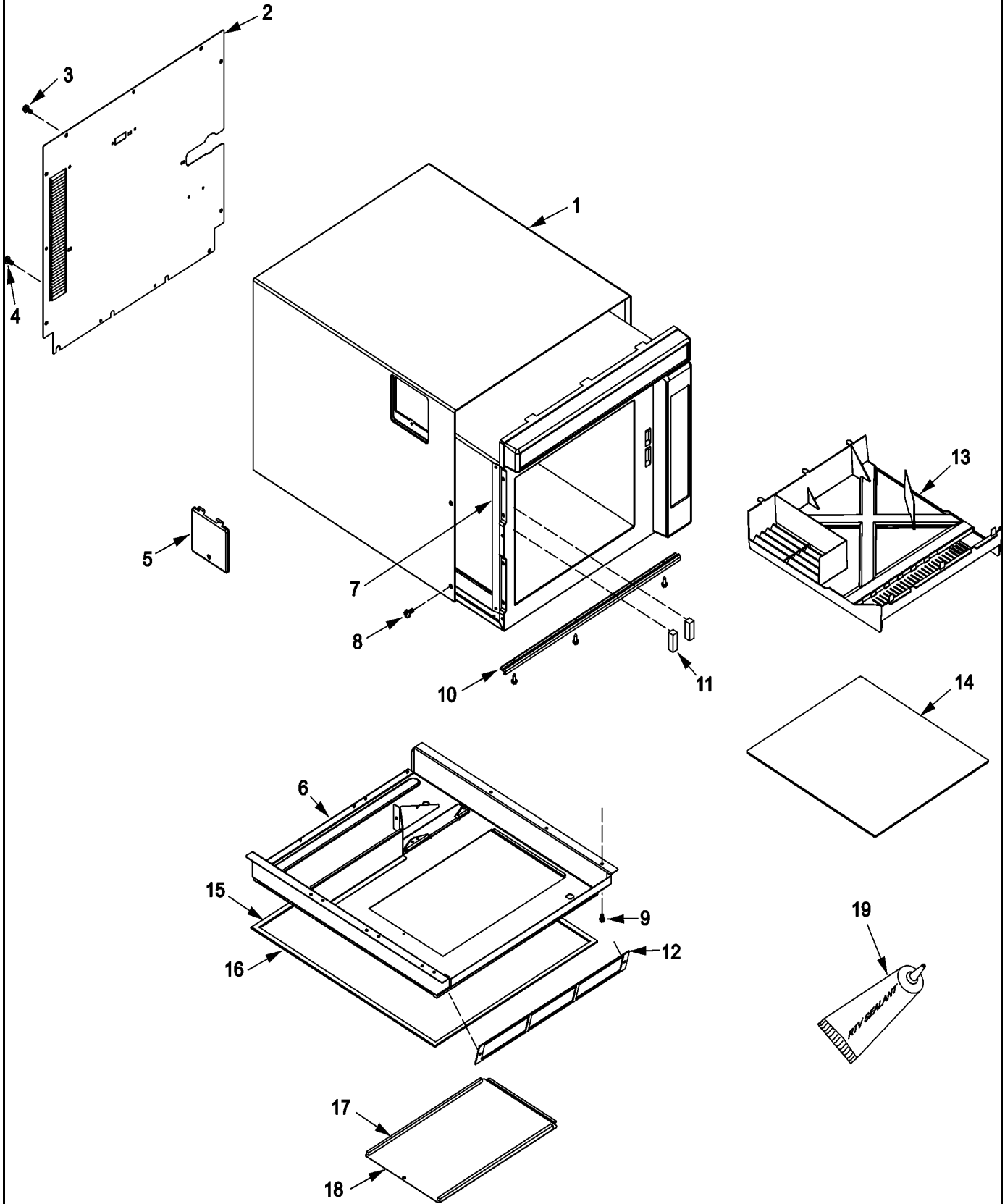

**Section: TRAY, GREASE SHIELD, CABINET,**

No.	Part No.	Description	Series Qty
1	10908901Q	WRAPPER-OC (SS)	1
2	R0156970	ASSY, ACCESS PANEL (REAR)	1
3	M0216703	SCREW ***	12
4	M0216716	SCREW	3
5	10785608	COVER LIGHT (SS)	1
-	M0249632	SCREW, T F	1
- N	M0288213	CLIP	1
6	10790304Q	BASE ASSY-GASKETS, ACCESS PNL	1
7	12189003	BRACKET,HINGE SUPPORT	1
-	M0231717	SCREW, TF	2
8	M0249632	SCREW, T F	4
9	M0220417	SCREW	6
-	M0249632	SCREW, T F	3
10 N	10909001	TRIM-OC (BRUSHED)	1
11	3010003001	SUPPORT-TRAY	2
-	M0274066	WASHER, NYLON	2
-	M0209701	SCREW, DECORATIVE	2
12	10853102	GRILLE, AIR INLET	1
13	10766601	SHIELD, GREASE	1
14	R0156942	TRAY-CERAMIC FLOOR W/SEALER	1
15	59001646	BASEPAN GASKET-CUT	2
16	59001647	BASEPAN GASKET-CUT	2
17	A3030301	GASKET (INCH)	2
18	10782402	BOTTOM ACCESS PANEL	1
-	M0216703	SCREW ***	1
19	M0275598	SEALER	1

Section: DOOR

Model: RC5MDTM2\_P1332836M

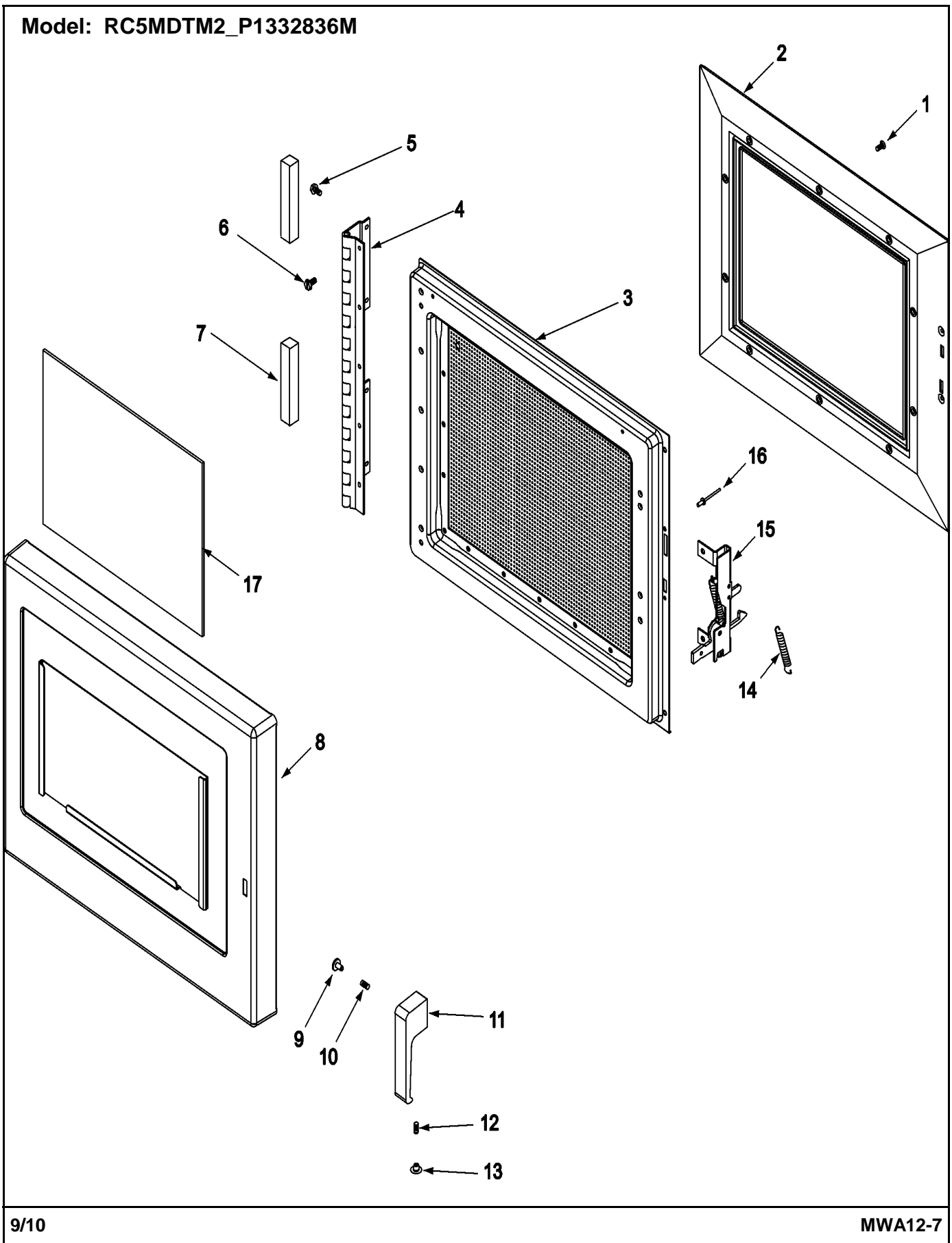

## Section: DOOR

No.	Part No.	Description	Series Qty
-	R0193574	MAGNETIC Y-DRIVE BIT	1
1	67003392	SCREW-HI LO Y-DRIVE HEAD	10
2	12002103	KIT, INNER DOOR/WINDOW ASSY	1
3	59001146	WELDMENT-INNER DOOR (BLK)	1
4	12003804	HINGE, DOOR	1
5	M0216716	SCREW	4
6	M0216703	SCREW ***	5
7	A3263904	GASKET	2
8	R0156920	OUTER DOOR/LENS RETAINER ASSY	1
9	12360703	PLUG, BUTTON (BLK) Note: PLUG, BUTTON (BLK) (SIDE)	1
10	M0208943	SET SCREW Note: SET SCREW (SIDE)	1
11	12490901	HANDLE, DOOR	1
12	M0208342	SCREW, SET Note: SCREW, SET (BOTTOM)	1
13	M0310305	PLUG, BUTTON (WHT) Note: PLUG, BUTTON (WHT) (BOTTOM)	1
14	C8893502	SPRING, DOOR LATCH	1
15	R0000282	LATCH KIT	1
16	A4539601	POP RIVET	2
17	10432501	MENU PANEL	1

**Section: SUPPLEMENTAL INFORMATION**

No.	Part No.	Description	Series Qty
1	N 59001700	USE & CARE-AMANA COM MICROWAVE	1
2	16022149	SVC MAN, INTL COMM MICRO	1
3	16022002	TECH SHT COMM MICRO	1
4	N 59001701	INSTRUCTIONS, QUICK START	1
5	<a href="#">12543202</a>	HARNESS-PC BOARD	1
6	<a href="#">59001635</a>	HARNESS-INTERLOCK/DISPLAY BD	1
7	<a href="#">12598201</a>	HARNESS, LOWER ANTENNA MOTOR	1
8	59001662	HARNESS-OVEN	1
9	59001491	HARNESS-HI VOLT	1
10	<a href="#">12002484</a>	KIT-CAV- 3 TUBE "S" CHASSIS	1

# Section: WIRING INFORMATION

Model: RC5MDTM2\_P1332836M

SCHEMATIC CONDITION: DOOR OPEN

230-240V 50Hz 3-WIRE

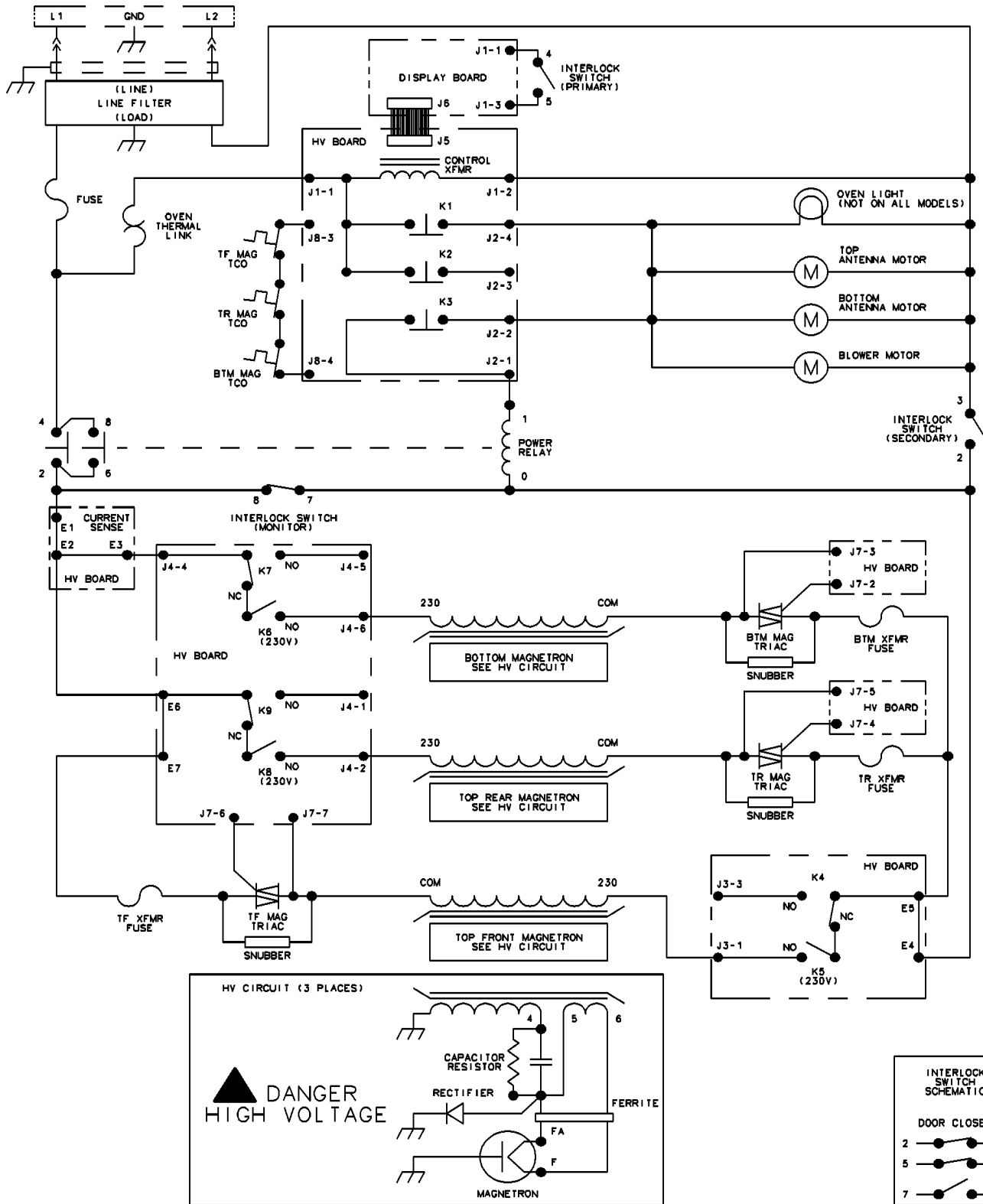

Section: FUSES, ANTENNAS, BLOWER, DUCTS,

Model: RC5MDTM2\_P1332836M

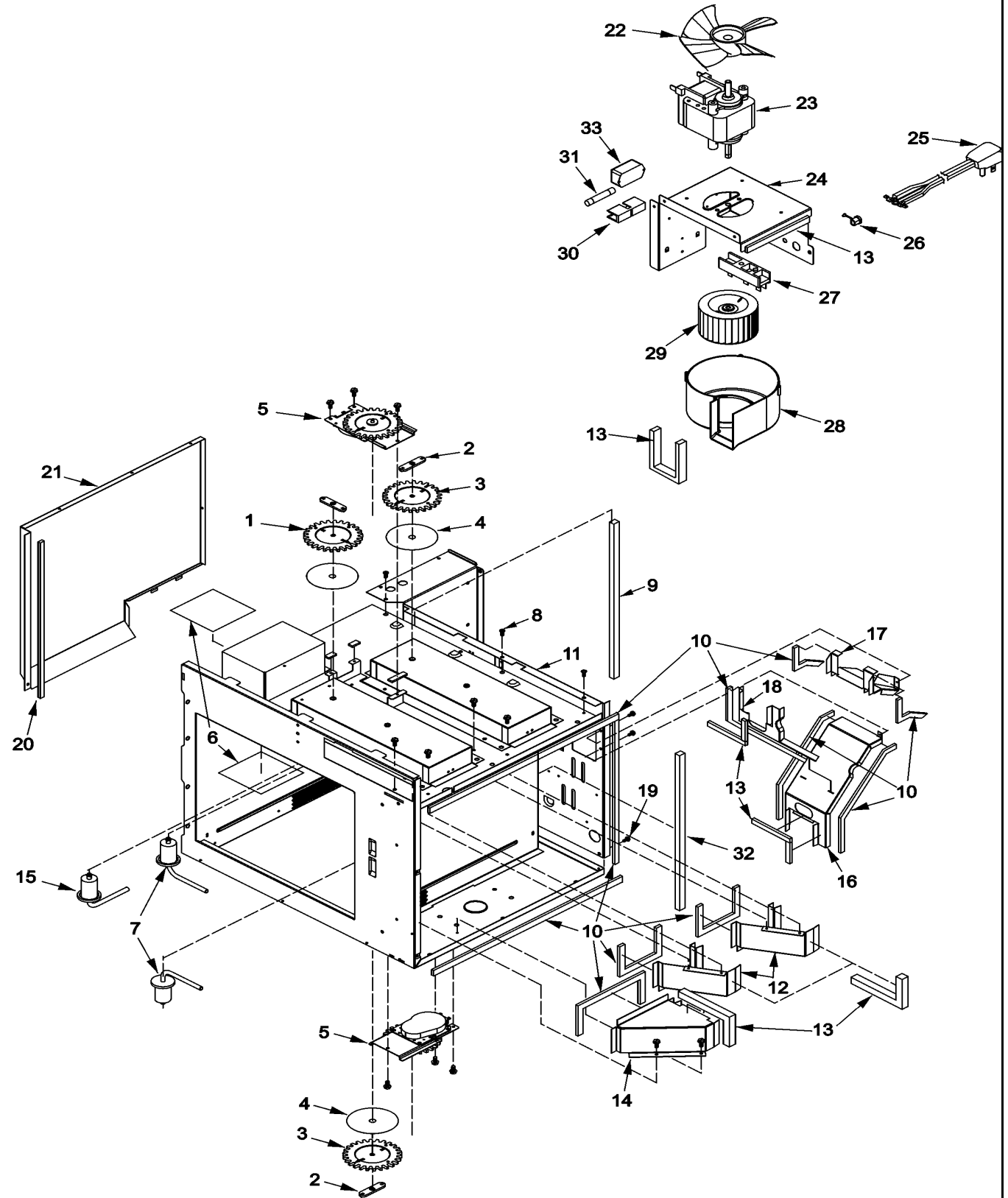

**Section: FUSES, ANTENNAS, BLOWER, DUCTS,**

No.	Part No.	Description	Series Qty
1	12570102	GEAR,SPUR (GRAY)	1
2	12570201	RETAINER,GEAR SHAFT	3
3	12570101	GEAR,SPUR	2
4	10903002	WASHER. SPUR GEAR	3
-	M0231717	SCREW, TF	6
5	R0130263	MOTOR-ANTENNA STIRRER (230V)	2
6	B8367701	WINDOW, OVEN LIGHT	2
7	R0130262	ANTENNA (STIRRER)	2
8	M0200316	SCREW	7
9	10966601	GASKET, NEOPRENE	1
10	A3030330	GASKET,PER FT	11
11	59001204	PANEL, PARTITION	1
12	R0156984	TOP EXHAUST DUCT-W/GASKET	2
-	M0216703	SCREW ***	4
13	A3030303	GASKET (PER FOOT)	4
-	M0216703	SCREW ***	2
14	R0156985	BOTTOM EXHAUST DUCT-W/GASKET	1
15	R0130261	ANTENNA, TOP FRONT (BLUE)	1
16	R0156987	BOTTOM DIVIDER DUCT-W/GASKET	1
17	R0156986	REAR DIVIDER DUCT-W/GASKET	1
-	M0216515	SCREW	1
-	M0216515	SCREW	1
18	R0156988	TOP DIVIDER DUCT-W/GASKET	1
19	5078-CC	SCREW	4
20	A3030301	GASKET (INCH)	1
21	10781901	DUCT, EXHAUST	1
22	B5706704	FAN BLADE	1
23	59001482	MOTOR, BLOWER	1
24	59001495	BRACKET, BLOWER	1
-	M0216515	SCREW	3
25	59001663	POWER CORD	1
26 N	59001664	RELIEF-STRAIN	1
-	M0234117	SCREW	1
27	B5677203	TERMINAL BLOCK	1
-	M0216517	SCREW	4
28	12552001	SCROLL,BLOWER	1
29	C3670809	WHEEL, BLOWER	1
30	10091101	FUSE HOLDER	1
31	M0805205	FUSE- 30A	1
32	A3030301	GASKET (INCH)	1
-	M0216703	SCREW ***	2
33	59001212	LINE FILTER	1

Section: ELECTRICAL COMPONENTS

Model: RC5MDTM2\_P1332836M

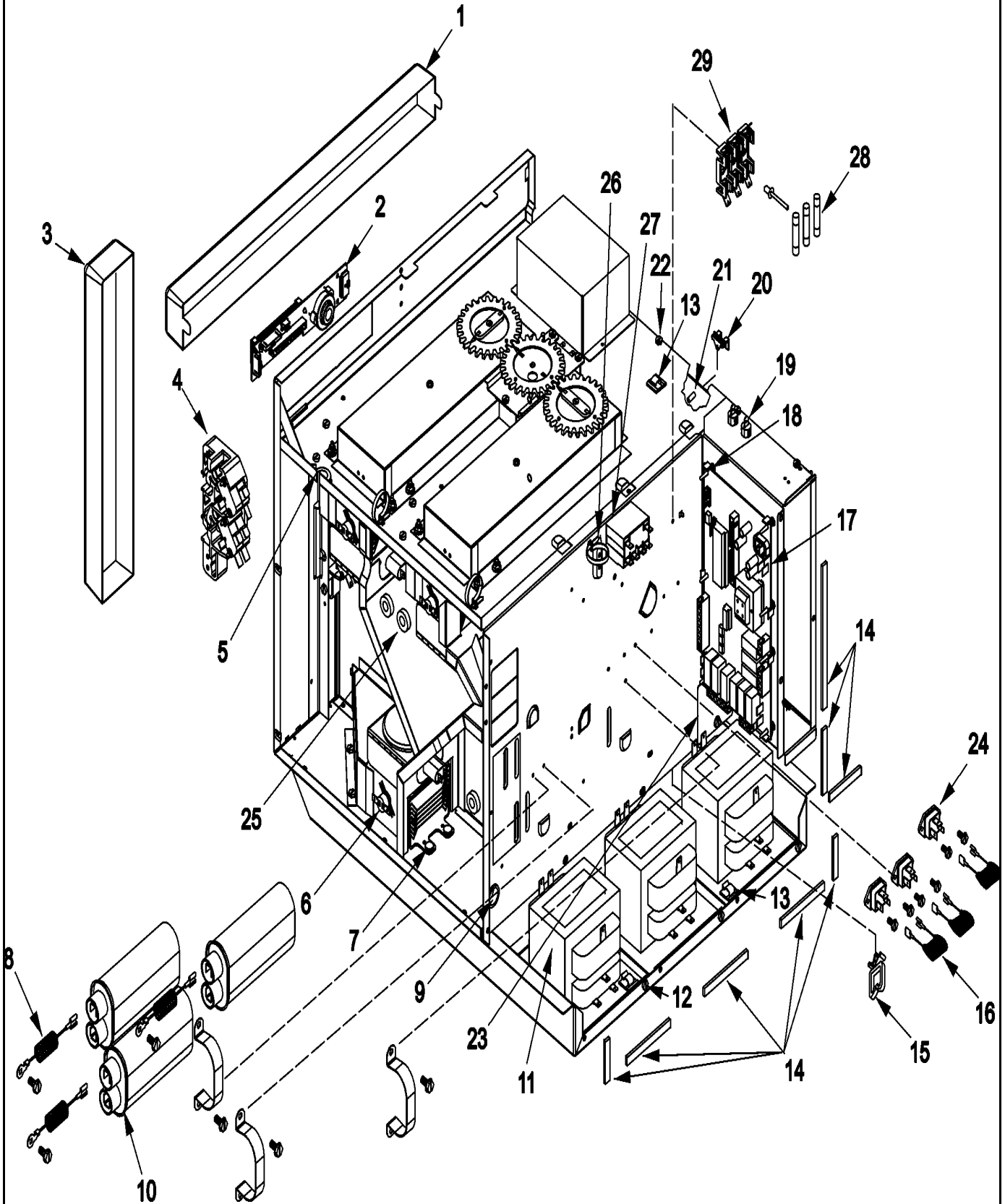

## Section: ELECTRICAL COMPONENTS

No.	Part No.	Description	Series Qty
1	R0130110	TOUCH PANEL(TOP)	1
-	M0231717	SCREW, TF	2
-	M0234114	SCREW	3
2	59004028	BOARD,DISPLAY ***	1
-	M0231717	SCREW, TF	2
3	R0130109	TOUCH PANEL(SIDE)	1
-	M0216517	SCREW	2
4	59001154	SWITCH, INTERLOCK	1
5	12164101	GROMMET-RUBBER	1
6	B5684124	CUTOUT-THERMAL MAGNETRON	3
-	M0229916	SCREW T.C	6
7	59001484	MAGNETRON-T	3
-	M0216515	SCREW	3
8	B8383102	RECTIFIER	3
9	59001128	BUSHING, SNAP	1
-	A4055406	STRAP, CAPACITOR	3
10	59001168	CAPACITOR-1.00	3
-	M0216515	SCREW	6
11	10788609	TRANSFORMER-HV 230V 50 HZ	3
12	M0216716	SCREW	2
13	M0104106	CLIP	3
14	A3030301	GASKET (INCH)	8
15	B5667304	WIRE CLIP	1
16	10172901Q	SNUBBER ASSEMBLY	3
17	59001124	BOARD,HV	1
18	M0590602	SUPPORT P-C BD A	7
19	M0325401	BUSHING,TERMINAL	2
20	59001211	THERMAL CUT-OFF	1
-	M0234422	SCREW	1
21	M0308801	CAP, PROTECTIVE-THREADED (RED)	1
22	M0231617	SCREW,TF	4
-	M0200316	SCREW	1
23	10847601	PLATE, PARTITION	1
-	M0216515	SCREW	6
24	R0157373	KIT, TRIAC ASSY	3
25	44780P01	TOROID (ARC SUPPRESSOR)	3
26	M0322202	TIE WIRE	3
27	12492202	RELAY	1
28	M0805102	FUSE 15 AMP	1
29	12136502	BLOCK-3 POLE FUSE	1
-	A4539601	POP RIVET	1

