



# Service / Training Manual

Commercial Microwave Oven



RC / MRC - 60 Hz  
January 2005 - 2013 Models  
16400023

© / ™ © 2013 Amana. All rights reserved. Brand used under license..



# Table of Contents

Important Safety Information.....	1-5
Installation.....	7
Specifications.....	8-9
Quick Start Reference Guide Sample RC / MRC.....	10-12
Top Touch Panel Configuration.....	13
Clear Call Service.....	14-18
Oven Construction RC / MRC.....	19-25
Oven Performance Test RC / MRC.....	26
Component Testing Procedures RC / MRC.....	27-38
Service Test (CPI Control) RC / MRC.....	39-41
Service Test (Invensy Control) RC / MRC.....	42-43
Display Diagnostics RC / MRC.....	44
Wiring Diagrams / Schematics Sample Two Tube Models.....	45-51
Wiring Diagrams / Schematics Sample Three Tube Models.....	52-55

# **1** | **Important Safety Information**

# Important Information

## Important Notices for Servicers and Consumers

ACP will not be responsible for personal injury or property damage from improper service procedures. Pride and workmanship go into every product to provide our customers with quality products. It is possible, however, that during its lifetime a product may require service. Products should be serviced only by a qualified service technician who is familiar with the safety procedures required in the repair and who is equipped with the proper tools, parts, testing instruments and the appropriate service information. IT IS THE TECHNICIANS RESPONSIBILITY TO REVIEW ALL APPROPRIATE SERVICE INFORMATION BEFORE BEGINNING REPAIRS.

 <b>WARNING</b>
To avoid risk of severe personal injury or death, disconnect power before working/servicing on appliance to avoid electrical shock.

To locate an authorized servicer please contact:

ComServ Support Center



Web Site  
WWW.ACPSOLUTIONS.COM

Telephone Number  
..... 1-866-426-2621 or 319-368-8195

E-Mail: [commercialservice@acpsolutions.com](mailto:commercialservice@acpsolutions.com)

Recognize Safety Symbols, Words, and Labels

 <b>DANGER</b>
---

DANGER— Immediate hazards which WILL result in severe personal injury or death.

 <b>WARNING</b>
--

WARNING— Hazards or unsafe practices which COULD result in severe personal injury or death.

 <b>CAUTION</b>
--

CAUTION— Hazards or unsafe practices which COULD result in minor personal injury, product or property damage.

# Important Safety Information



## WARNING

Read the following information to avoid possible exposure to microwave radiation:

The basic design of the Microwave Oven makes it an inherently safe device to both use and service.

However, there are some precautions which should be followed when servicing the microwave to maintain this safety. These are as follows:

1. Always operate the unit from an adequately grounded outlet. Do not operate on a two-wire extension cord.
2. Before servicing the unit (if unit is operable) perform the microwave leakage test.
3. The oven should never be operated if the door does not fit properly against the seal, the hinges or hinge bearings are damaged or broken; the choke is damaged, (pieces missing, etc.); or any other visible damage can be noted. Check the choke area to ensure that this area is clean and free of all foreign matter.
4. If the oven operates with the door open and produces microwave energy, take the following steps:
  - A. Tell the user not to operate the oven.
  - B. Contact ACP ComServ immediately.
5. Always have the oven disconnected when the outer case is removed except when making the "live" tests called for in the Service Manual. Do not reach into the equipment area while the unit is energized. Make all connections for the test and check them for tightness before plugging the cord into the outlet.
6. Always ground the capacitors on the magnetron filter box with an insulated-handle screwdriver before working in the high voltage area of the equipment compartment. Some types of failures will leave a charge in these capacitors and the discharge could cause a reflex action which could make you injure yourself.
7. Always remember that in the area of the transformer there is HIGH VOLTAGE. When the unit is operating keep this area clear and free of anything which could possibly cause an arc or ground, etc.
8. Do not for any reason defeat the interlock switches there is not valid reason for this action at any time; nor will it be condoned by ACP.
9. IMPORTANT: Before returning a unit to a customer, be sure to check for proper switch interlock action.
10. The Microwave Oven should never be operated with any components removed and/or bypassed or when any of the safety interlocks are found to be defective, or when any of the seal surfaces are defective, missing, or damaged.
11. All microwave ovens meet all requirements of the radiation control for Health and Safety Act of 1968. Due to measurement uncertainties, the maximum leakage for the field will be  $4\text{mw}/\text{cm}^2$ .
12. To ensure that the unit does not emit excessive microwave leakage and to meet the Department of Health and Human Services guidelines, check the oven for microwave leakage using a microwave oven leakage meter that complies with US Government CDRH / FDA / DHHS requirements and or any other local government requirements. The maximum leakage level allowed by ACP is  $4\text{mw}/\text{cm}^2$ .
13. If servicer encounters an emission reading over  $4\text{mw}/\text{cm}^2$ , the servicer is to cease repair and contact the ACP ComServ Department immediately for further direction. ACP will contact the proper Government Agency upon verification of the test results.

# IMPORTANT SAFETY INSTRUCTIONS



This is the safety alert symbol. It is used to alert you to potential personal injury hazards. Obey all safety messages that follow this symbol to avoid possible injury or death.



## WARNING

When using electrical equipment, basic safety precautions should be followed to reduce the risk of burns, electrical shock, fire, or injury to persons including the following.

1. READ all instructions before using equipment.
2. READ AND FOLLOW the specific “PRECAUTIONS TO AVOID POSSIBLE EXPOSURE TO EXCESSIVE MICROWAVE ENERGY” on this page.
3. This equipment **MUST BE GROUNDED**. Connect only to properly **GROUNDED** outlet. See “**GROUNDED / EARTHING INSTRUCTIONS**” on page 5.
4. Install or locate this equipment **ONLY** in accordance with the installation instructions in this manual.
5. Some products such as whole eggs and sealed containers—for example, closed glass jars—are able to explode and **SHOULD NOT** be **HEATED** in this oven.
6. Use this equipment **ONLY** for its intended use as described in this manual. Do not use corrosive chemicals or vapors in this equipment. This type of oven is specifically designed to heat, cook, or dry food. It is not designed for industrial or laboratory use.
7. As with any equipment, **CLOSE SUPERVISION** is necessary when used by **CHILDREN**.
8. See door cleaning instructions on page A-4 of this owners manual.
9. **DO NOT** heat baby bottles in oven.
10. Baby food jars shall be open when heated and contents stirred or shaken before consumption, in order to avoid burns.
11. **DO NOT** operate this equipment if it has a damaged cord or plug, if it is not working properly, or if it has been damaged or dropped.
12. This equipment, including power cord, must be serviced **ONLY** by qualified service personnel. Special tools are required to service equipment. Contact nearest authorized service facility for examination, repair, or adjustment.
13. **DO NOT** cover or block louvers or other openings on equipment.
14. **DO NOT** store this equipment outdoors. **DO NOT** use this product near water – for example, near a kitchen sink, in a wet basement, a swimming pool, or a similar location.
15. **DO NOT** immerse cord or plug in water.
16. Keep cord **AWAY** from **HEATED** surfaces.
17. **DO NOT** let cord hang over edge of table or counter.
18. For commercial use only.

## PRECAUTIONS TO AVOID POSSIBLE EXPOSURE TO EXCESSIVE MICROWAVE ENERGY

- A. **DO NOT** attempt to operate this oven with the door open since open door operation can result in harmful exposure to microwave energy. It is important not to defeat or tamper with the safety interlocks.
- B. **DO NOT** place any object between the oven front face and the door too allow soil or cleaner residue to accumulate on sealing surfaces.
- C. **DO NOT** operate the oven if it is damaged. It is particularly important that the oven door close properly and that there is no damage to the:
  1. door (bent)
  2. hinges and latches (broken or loosened)
  3. door seals and sealing surfaces.
- D. The oven should not be adjusted or repaired by anyone except properly qualified service personnel.

## SAVE THESE INSTRUCTIONS

# IMPORTANT SAFETY INSTRUCTIONS



## WARNING

To avoid risk of fire in the oven cavity:

- a. DO NOT overcook food. Carefully attend oven when paper, plastic, or other combustible materials are placed inside the oven to facilitate cooking.
- b. Remove wire twist-ties from paper or plastic bags before placing bag in oven.
- c. If materials inside the oven ignite, keep oven door CLOSED, turn oven off and disconnect the power cord, or shut off power at the fuse or circuit breaker panel.
- d. DO NOT use the cavity for storage. DO NOT leave paper products, cooking utensils, or food in the cavity when not in use.



## WARNING

Liquids such as water, coffee, or tea are able to be overheated beyond the boiling point without appearing to be boiling due to surface tension of the liquid. Visible bubbling or boiling when the container is removed from the microwave oven is not always present. THIS COULD RESULT IN VERY HOT LIQUIDS SUDDENLY BOILING OVER WHEN A SPOON OR OTHER UTENSIL IS INSERTED INTO THE LIQUID. To reduce the risk of injury to persons:

- i) Do not overheat the liquid.
- ii) Stir the liquid both before and halfway through heating it.
- iii) Do not use straight-sided containers with narrow necks.
- iv) After heating, allow the container to stand in the microwave oven for a short time before removing the container.
- v) Use extreme care when inserting a spoon or other utensil into the container.



## CAUTION

To avoid personal injury or property damage, observe the following:

1. Do not deep fat fry in oven. Fat could overheat and be hazardous to handle.
2. Do not cook or reheat eggs in shell or with an unbroken yolk using microwave energy. Pressure may build up and erupt. Pierce yolk with fork or knife before cooking.
3. Pierce skin of potatoes, tomatoes, and similar foods before cooking with microwave energy. When skin is pierced, steam escapes evenly.
4. Do not operate equipment without load or food in oven cavity.
5. Microwave popcorn should not be popped in oven.
6. Do not use regular cooking thermometers in oven. Most cooking thermometers contain mercury and may cause an electrical arc, malfunction, or damage to oven.
7. Do not use metal utensils in oven.
8. Do not use aluminum foil in oven
9. Never use paper, plastic, or other combustible materials that are not intended for cooking.
10. When cooking with paper, plastic, or other combustible materials, follow manufacturer's recommendations on product use.
11. Do not use paper towels which contain nylon or other synthetic fibers. Heated synthetics could melt and cause paper to ignite.
12. Do not heat sealed containers or plastic bags in oven. Food or liquid could expand quickly and cause container or bag to break. Pierce or open container or bag before heating.
13. To avoid pacemaker malfunction, consult physician or pacemaker manufacturer about effects of microwave energy on pacemaker.
14. An authorized servicer MUST inspect equipment annually. Record all inspections and repairs for future use.

## SAVE THESE INSTRUCTIONS

# 2

**RC / MRC**

**60 Hz**

## **Specifications**

### **Installation**

- Unpacking the oven
- Oven Clearances

### **Power Specification**

- Input
- Output
- Consumption

### **Dimensions**

- Weight

# Installation

## STEP 1 - Unpack Oven

- Inspect oven for damage such as dents in door or inside oven cavity.
- Report any dents or breakage to source of purchase immediately.  
**Do not attempt to use oven if damaged.**
- Remove all packing materials from oven interior.
- If oven has been stored in extremely cold area, wait a few hours before connecting power.

## STEP 2 - Place Oven on Counter

- Do not install oven next to or above source of heat or moisture such as pizza oven, deep fat fryer or pasta cooker. This could cause microwave oven to operate improperly and could shorten life of electrical parts.
- Do not block or obstruct oven filter. Allow access for cleaning.
- Install oven on level countertop surface.
- Outlet should be located so that plug is accessible when oven is in place.

**⚠ WARNING**

**Excessive Weight Hazard**

**Use two or more people to move and install oven.**

**Failure to do so can result in back or other injury.**

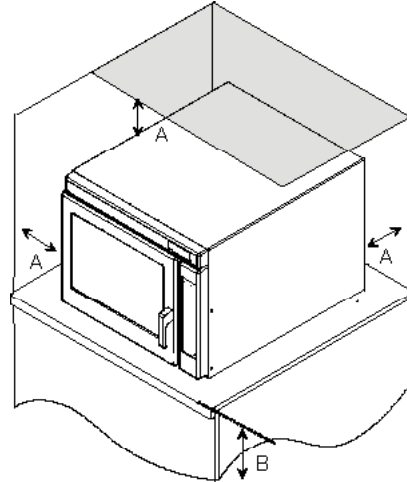

### Oven Clearances

- A—Allow at least 2" (5.1 cm) of clearance around top and sides of oven. Proper air flow around oven cools electrical components. With restricted air flow, oven may not operate properly and life of electrical parts is reduced.
- B—Install oven so oven bottom is at least 3 feet (91.5 cm) above floor.

# Specifications RC / MRC

Models	RC17S2 MRC17S2 RC17SDOSI	RC22S2 MRC22S2	RC30S2 MRC30S2	MC23MPW2 MC23MPTW2 WDYRC22
<b>Power Source</b>				
Voltage AC	208 - 240V	208 - 240V	208 - 240V	208 - 240V
Amperage	20 A	20 A	30 A	20 A
Frequency	60 Hz	60 Hz	60 Hz	60 Hz
Single Phase, 3 wire grounded	X	X	X	X
Plug Configuration / Cord	NEMA 6-20	NEMA 6-20	NEMA 6-30	NEMA L6 -20P Pin and Sleeve
<b>Power Output</b>				
Nominal microwave energy (IEC705)	1700 W	2200 W	3000W	2000W
Minimum temperature rise	17°F	22°F	30°F	20°F
Operating Frequency	2450 MHz	2450 MHz	2450 MHz	2450 MHz
<b>Power Consumption</b>				
Cook Condition Microwave	2700 W	3200 W	4400 W	3200 W
240V Amps	11.3 A	13.3 A	18.3 A	13.3 A
208V Amps	13.0 A	15.4 A	21.2 A	15.4 A
<b>Dimensions</b>				
<b>Cabinet</b>				
Width	19¼" (489)	19¼" (489)	19¼" (489)	19¼" (489)
Height	18⅛" (460)	18⅛" (460)	18⅛" (460)	18⅛" (460)
Depth	25½" (648)	25½" (648)	25½" (648)	25½" (648)
<b>Cavity Dimensions</b>				
Width	13" (330)	13" (330)	13" (330)	13" (330)
Height	8½" (216)	8½" (216)	8½" (216)	8½" (216)
Depth	15" (381)	15" (381)	15" (381)	15" (381)
<b>Weight</b>				
Crated	101 lbs (46 kg.)	101 lbs (46 kg.)	123 lbs (56 kg.)	123 lbs (56 kg.)
Uncrated	94 lbs (43 kg.)	94 lbs (43 kg.)	115 lbs (52 kg.)	115 lbs (52 kg.)

# Specifications RC / MRC

<b>Models</b>	<b>KFC2W2</b>	<b>DQ22HSI2</b>
<b>Power Source</b>		
Voltage AC	208 - 240V	208 - 240V
Amperage	30 A	20 A
Frequency	60 Hz	60 Hz
Single Phase, 3 wire grounded	X	X
Plug Configuration / Cord	NEMA 6-30	NEMA 6-20
<b>Power Output</b>		
Nominal microwave energy (IEC705)	2700 W	2200 W
Minimum temperature rise	27°F	22°F
Operating Frequency	2450 MHz	2450 MHz
<b>Power Consumption</b>		
Cook Condition Microwave	4000 W	3300 W
240V Amps	16.7 A	13.8 A
208V Amps	19.2 A	15.9 A
<b>Dimensions</b>		
<b>Cabinet</b>		
Width	19¼" (489)	19¼" (489)
Height	18⅛" (460)	18⅛" (460)
Depth	25½" (648)	25½" (648)
<b>Cavity Dimensions</b>		
Width	13" (330)	13" (330)
Height	8½" (216)	8½" (216)
Depth	15" (381)	15" (381)
<b>Weight</b>		
Crated	123 lbs (56 kg.)	101 lbs (46 kg.)
Uncrated	115 lbs (52 kg.)	94 lbs (43 kg.)

# **3** | **RC / MRC** **60 Hz Quick Start** **Reference Guide Sample**

# SAMPLE



## Quick Start Reference Guide

Refer to Product Safety Manual for Safety Statements

Complete Owner's Manual available online

### CLEAN FILTER

This oven displays CLEAN FILTER at user defined intervals. When the message displays ACP recommends cleaning the air filter thoroughly.

**Cleaning the air filter will not shut off the message.** The message will stop displaying automatically after 24 hours. Depending on microwave use and environmental conditions, the filter may need to be cleaned more frequently. Once the frequency is determined, set the option for the appropriate time frame.

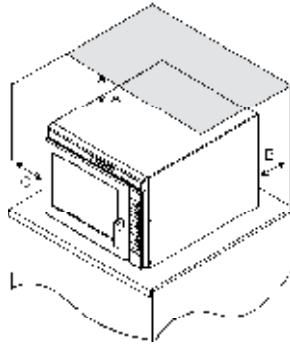

### Oven Clearances

A—For North American (UL/CSA) models, allow at least 2" (5.1 cm) of clearance around top of oven. For International (50 Hz) models, allow at least 7" (17.8 cm) of clearance around top of oven. Proper air flow around oven cools electrical components. With restricted air flow, oven may not operate properly and life of electrical parts is reduced.

B—Allow at least 2 9/16" (6.5 cm) between air discharge on back of oven and back wall.

C—Allow at least 2" (5.1 cm) around sides of oven.

## So...how do I use it?

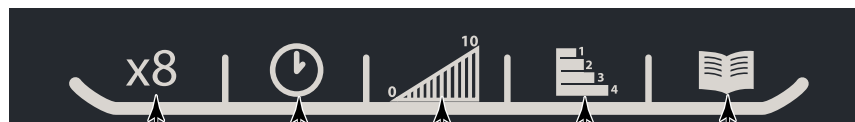

Quantity Time Entry Power Level Stage Program Save

### 2 Preprogrammed Pads

To cook food using preprogrammed cooking sequences.

1. Open oven door and place food in oven. Close door.
  - To add additional servings press QUANTITY pad.
  - Up to eight quantities can be added.
2. Press desired pad.
3. Oven begins to cook.
4. At end of cooking cycle oven beeps and shuts off. **DONE** displays.

### Mid-Cycle Pause

To add a pause to a programmed cooking cycle:

1. Press HIDDEN PAD after entering time or power level.
2. A short beep sounds. This indicates the program is set for a mid-cycle pause.
3. Continue programming pad as desired.

When programmed pad is used, pause will occur in the middle of total programmed time. Oven will beep continuously and **Program Paused** displays until door is open and shut. To continue cycle, press START pad.

### Manual Operation

To cook food using a specific entered time and power level.

1. Open oven door and place food in oven. Close door.
2. Press TIME ENTRY pad and enter cooking time.
3. Press POWER LEVEL pad to change power level if desired.
  - For a lower microwave power, press pads 1 (for 10%) through 9 (for 90%).
4. If stage cooking is desired, press STAGE pad and repeat steps 2 through 4.
5. Press START pad.
6. At end of cooking cycle oven beeps and shuts off. **DONE** displays.

### Programming Pads

1. **READY** must be in the display. If not, open and close door.
2. Press PROGRAM SAVE pad.
  - Programming mode begins.
  - Enter Program to Add/Review: displays.
3. Press pad to be programmed or reprogrammed.
  - Display will change to review all settings for the pad.
  - The pad number that is being programmed displays beside the word **ITEM**.
4. Press TIME ENTRY to program amount of cooking time.
  - Enter desired cooking time by using numeric key pads.
  - Maximum cooking time is 60 minutes.
5. Press POWER LEVEL to program level of microwave power.
  - Press numeric key pad for desired level. Press numeric key pad again to set power level to 100%.
  - For a lower microwave power, press pads 1 (for 10%) through 9 (for 90%).
6. Press Quantity pad if different cooking factor is desired.
  - Default of CF:80 displays.
  - Enter desired cooking factor by using numeric key pads (1 for 10% through 0 for 100%).
7. Press PROGRAM SAVE to save the program changes.

8. To discard changes, press STOP/RESET.

# SAMPLE

## Quick Start Reference Guide

Refer to *Product Safety Manual* for Safety Statements

Complete Owner's Manual available online

### Changing user options

Options such as single or double pad programming and beep volume can be changed to suit individual preferences.

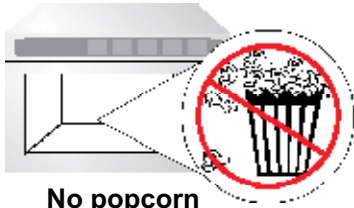

No popcorn

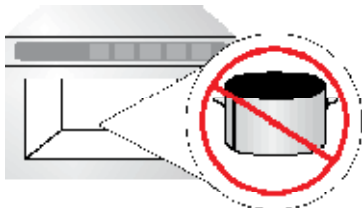

No metal pans

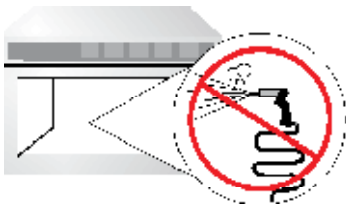

DO NOT power spray



Amana



MenuMaster

#### To change options:

- Press hidden pad.
  - Pad is unmarked.
  - The display remains blank when hidden pad is pressed.
- Press PROGRAM SAVE pad.
  - The first user option will display. Oven is now in options mode.
- Press number pad that controls option to be changed.
  - See table below for options.
  - Current option will display.
- Press number pad again to change the option.
  - Each time pad is pressed, option will change.
  - Match code displayed with code for desired option.
  - Changes take affect after pad is pressed.
  - To change additional options, repeat steps 3 and 4.
- Press PROGRAM SAVE to return to READY, or open and close oven door.

Numbered Pads	Displays	Options (Factory settings bold)
1 Double Digit Entry	Disabled Enabled	Allows 10 (0-9) preprogrammed pads. <b>Allows 100 (00-99) preprogrammed pads.</b>
2 Manual Programming	Disabled Enabled	Manual time entry/cooking not allowed <b>Manual time entry/cooking allowed</b>
3 Reset on Door Open	Disabled Enabled	Opening oven door does not reset oven back to ready <b>Opening oven door resets the oven back to ready mode</b>
4 Keybeep	OFF ON	Keys do not beep when pressed (keybeep off) <b>Keys beep when pressed (keybeep on)</b>
5 Speaker Volume	OFF LOW MEDIUM HIGH	Keybeep volume OFF Keybeep volume LOW <b>Keybeep volume MEDIUM</b> Keybeep volume HIGH
6 End of Cook Signal	Solid Beep 3 Second Beep 4 Beeps Once 4 Beeps Repeating	Food done signal is a continuous beep until reset by user <b>Food done signal is a three second beep</b> Food done signal is four beeps continuously Food done signal is four beeps, four times
7 Keypad Active	15 Seconds 30 Seconds 60 Seconds 120 Seconds Always	Keypad time entry window is 15 seconds <b>Keypad time entry window is 30 seconds</b> Keypad time entry window is one minute Keypad time entry window is two minutes Keypad time entry window is always active
Stage Pad Clean Filter Message (Frequency)	Disabled Weekly Monthly Quarterly	Oven will not display Clean Filter <b>Oven will display Clean Filter every seven (7) days</b> Oven will display Clean Filter every thirty (30) days Oven will display Clean Filter every ninety (90) days

# Top Touch Panel Configuration

Amana

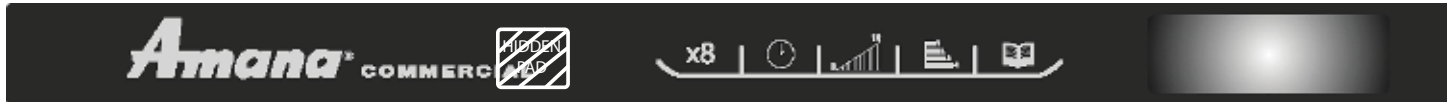

Hidden Pad

Menumaster



Hidden Pad

MC23MPW2 / MC23MPTW2



Hidden Pad

DQ22HSI2



Hidden Pad

KFC2W2



Hidden Pad

WDYRC22

Style A



Hidden Pad

Time Entry

Program Save

Style B



# CALL SERV

## Information Sheet

If unit has **CALL SERV** displayed and the unit appears to be heating properly, proceed as follows:

1. Door **MUST** be CLOSED.
2. CPI board models must be in Ready mode and blower operating (Open & close door if blower is not operating). Invensy board models must be in Off condition or Initial Power-Up mode.



OFF condition

Initial Power-Up

Ready

Ready

CPI Board Blue Display



Invensy Board Green Display

**NOTE:** Pads will not beep during this procedure.

3. Press and release **HIDDEN** pad on the Top Touch Panel.

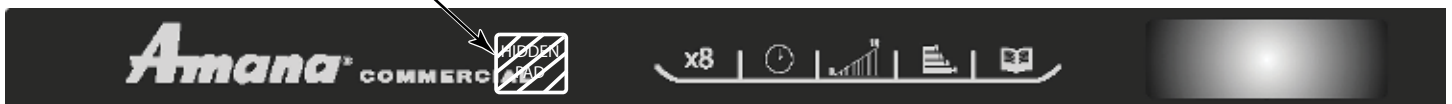

4. Press **1,3,5,7,** and **9** pads on the Side Touch Panel.
5. Display will indicate **SErv** (Service Test Mode) or **Service Mode**.



Invensy Board Green Display

Service Mode  
60HZ 208V

CPI Board Blue Display

6. Press pad **0** to clear **CALL SERV** from the display. Display will indicate **CLr** or **CALL SERVICE Alarm Cleared**.



Invensy Board Green Display

CALL SERVICE  
Alarm Cleared

CPI Board Blue Display

7. Press **STOP/RESET** pad to exit the Service Test Mode.
8. Place a 1 quart water load inside the oven cavity.
9. Use a Pre-programmed pad to operate the oven for at least 10 seconds.
10. Does **CALL SERV** appear in the display?
  - NO - oven is ready for normal use.
  - Yes - call 866-426-2621 to arrange service.

# CALL SERV

## Information Sheet

If unit has **CALL SERV** displayed and the unit appears to be heating properly, proceed as follows:

1. Door **MUST** be CLOSED.
2. CPI board models must be in Ready mode and blower operating (Open & close door if blower is not operating). Invensy board models must be in Off condition or Initial Power-Up mode.



OFF condition

Initial Power-Up

Ready

Ready

CPI Board Blue Display



Invensy Board Green Display

**NOTE:** Pads will not beep during this procedure.

3. Press and release **HIDDEN** pad on the Top Touch Panel.



4. Press **1,3,5,7,** and **9** pads on the Side Touch Panel.
5. Display will indicate **SErv** (Service Test Mode) or **Service Mode**.



Invensy Board Green Display

Service Mode  
60HZ 208V

CPI Board Blue Display

6. Press pad **0** to clear **CALL SERV** from the display. Display will indicate **CLr** or **CALL SERVICE Alarm Cleared**.



Invensy Board Green Display

CALL SERVICE  
Alarm Cleared

CPI Board Blue Display

7. Press **STOP/RESET** pad to exit the Service Test Mode.
8. Place a 1 quart water load inside the oven cavity.
9. Use a Pre-programmed pad to operate the oven for at least 10 seconds.
10. Does **CALL SERV** appear in the display?
  - NO - oven is ready for normal use.
  - Yes - call 866-426-2621 to arrange service.

# CALL SERV

## Information Sheet

If unit has **CALL SERV** displayed and the unit appears to be heating properly, proceed as follows:

1. Door **MUST** be CLOSED.
2. CPI board models must be in Ready mode and blower operating (Open & close door if blower is not operating). Invensy board models must be in Off condition or Initial Power-Up mode.



OFF condition

Initial Power-Up

Ready

Ready

CPI Board Blue Display



Invensy Board Green Display

**NOTE:** Pads will not beep during this procedure.

3. Press and release **HIDDEN** pad on the Top Touch Panel.



4. Press **1,3,5,7,** and **9** pads on the Side Touch Panel.
5. Display will indicate **SErv** (Service Test Mode) or **Service Mode**.



Invensy Board Green Display

Service Mode  
60HZ 208V

CPI Board Blue Display

6. Press pad **0** to clear **CALL SERV** from the display. Display will indicate **CLr** or **CALL SERVICE Alarm Cleared**.



Invensy Board Green Display

CALL SERVICE  
Alarm Cleared

CPI Board Blue Display

7. Press **STOP/RESET** pad to exit the Service Test Mode.
8. Place a 1 quart water load inside the oven cavity.
9. Use a Pre-programmed pad to operate the oven for at least 10 seconds.
10. Does **CALL SERV** appear in the display?
  - NO - oven is ready for normal use.
  - Yes - call 866-426-2621 to arrange service.

# CALL SERV

## Information Sheet

If unit has **CALL SERV** displayed and the unit appears to be heating properly, proceed as follows:

1. Door **MUST** be CLOSED.
2. CPI board models must be in Ready mode and blower operating (Open & close door if blower is not operating). Invensy board models must be in Off condition or Initial Power-Up mode.



OFF condition

Initial Power-Up

Ready

Ready

CPI Board Blue Display



Invensy Board Green Display

**NOTE:** Pads will not beep during this procedure.

3. Press and release **HIDDEN** pad on the Top Touch Panel.



4. Press **1,3,5,7,** and **9** pads on the Side Touch Panel.
5. Display will indicate **SErv** (Service Test Mode) or **Service Mode**.



Invensy Board Green Display

Service Mode  
60HZ 208V

CPI Board Blue Display

6. Press pad **0** to clear **CALL SERV** from the display. Display will indicate **CLr** or **CALL SERVICE Alarm Cleared**.



Invensy Board Green Display

CALL SERVICE  
Alarm Cleared

CPI Board Blue Display

7. Press **STOP/RESET** pad to exit the Service Test Mode.
8. Place a 1 quart water load inside the oven cavity.
9. Use a Pre-programmed pad to operate the oven for at least 10 seconds.
10. Does **CALL SERV** appear in the display?
  - NO - oven is ready for normal use.
  - Yes - call 866-426-2621 to arrange service.

# CALL SERV

## Information Sheet

If unit has **CALL SERV** displayed and the unit appears to be heating properly, proceed as follows:

1. Door **MUST** be CLOSED.
2. CPI board models must be in Ready mode and blower operating (Open & close door if blower is not operating). Invensy board models must be in Off condition or Initial Power-Up mode.



OFF condition

Initial Power-Up

Ready

Ready

CPI Board Blue Display



Invensy Board Green Display

**NOTE:** Pads will not beep during this procedure.

3. Press and release **HIDDEN** pad on the Top Touch Panel.

Style A



Style B



4. Press **1,3,5,7,** and **9** pads on the Side Touch Panel.
5. Display will indicate **SErv** (Service Test Mode) or **Service Mode**.



Invensy Board Green Display

Service Mode  
60HZ 208V

CPI Board Blue Display

6. Press pad **0** to clear **CALL SERV** from the display. Display will indicate **CLr** or **CALL SERVICE Alarm Cleared**.



Invensy Board Green Display

CALL SERVICE  
Alarm Cleared

CPI Board Blue Display

7. Press **STOP/RESET** pad to exit the Service Test Mode.
8. Place a 1 quart water load inside the oven cavity.
9. Use a Pre-programmed pad to operate the oven for at least 10 seconds.
10. Does **CALL SERV** appear in the display?
  - NO - oven is ready for normal use.
  - Yes - call 866-426-2621 to arrange service.

# **4** | **RC / MRC** **60 Hz Oven Construction**

# Oven Construction

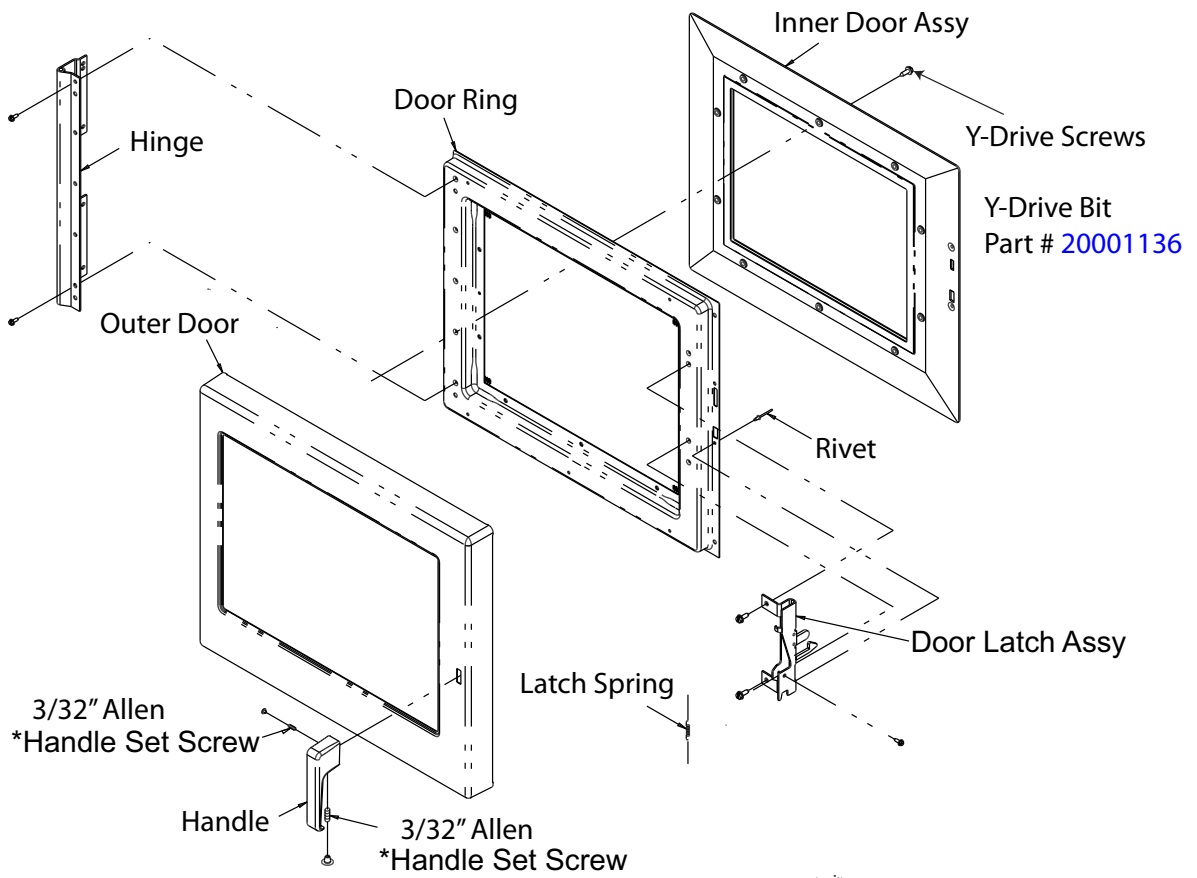

\* Apply thread lock compound to threads, tighten side handle set screw first.

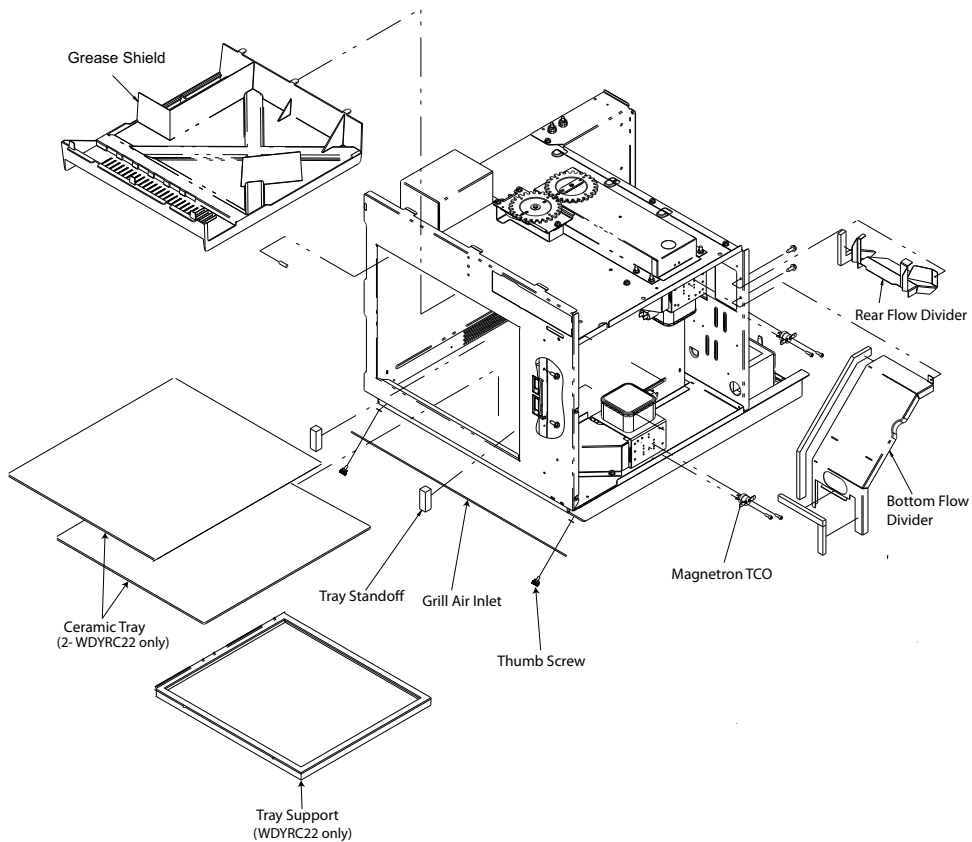

# Oven Construction Three Magnetron Models

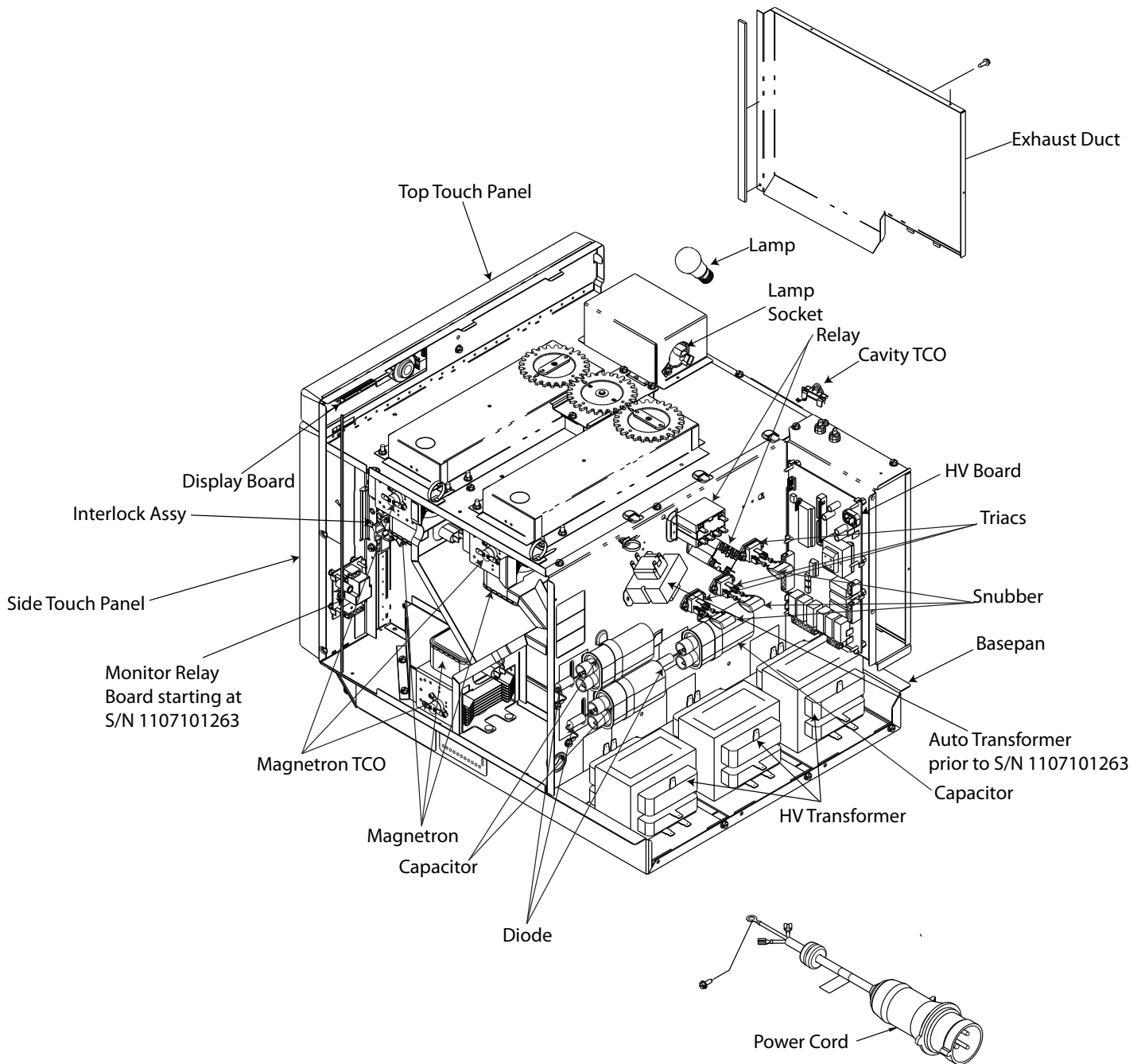

# Oven Construction Two Magnetron Models

Dual HV transformer prior to serial number 1204101620

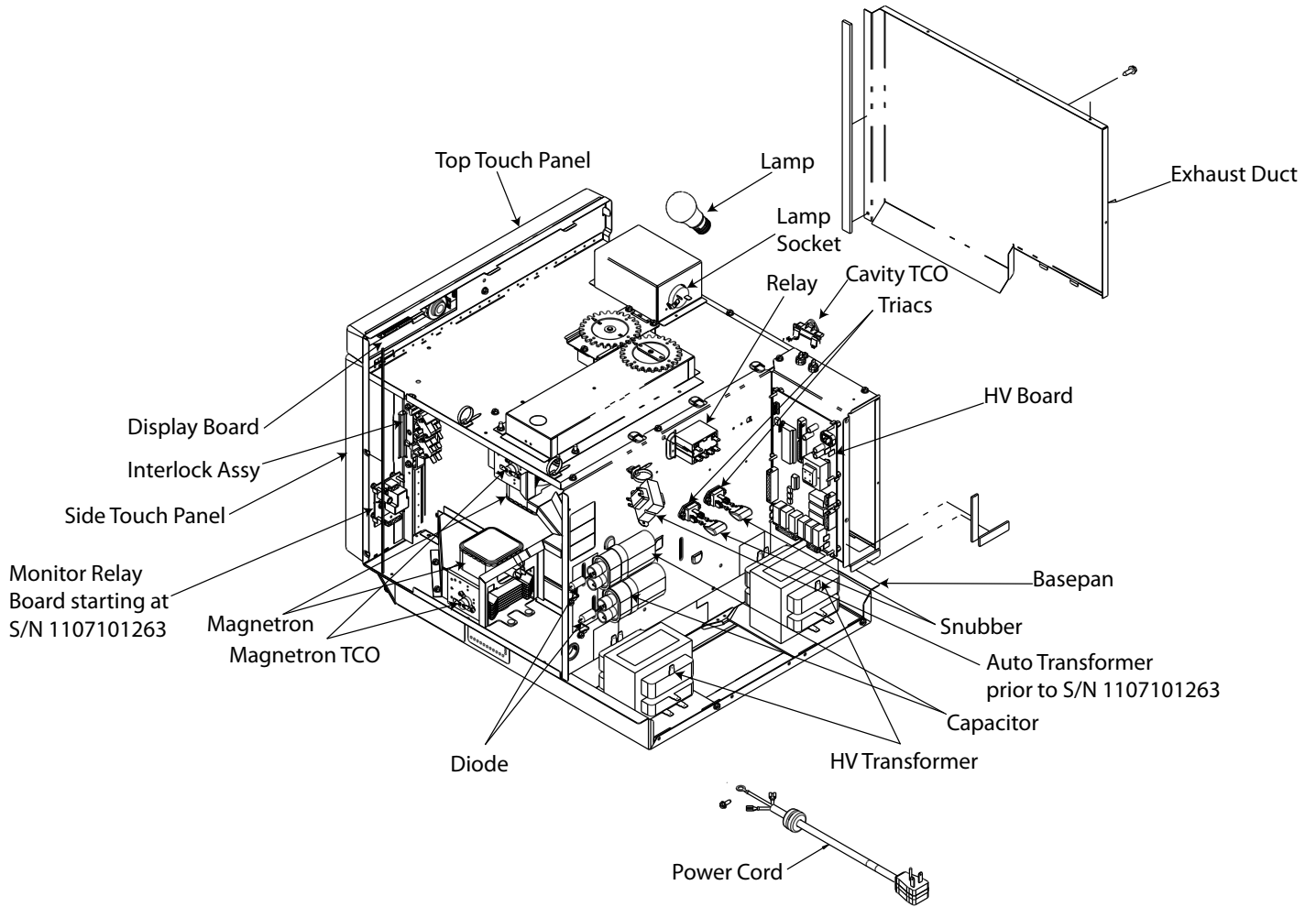

# Oven Construction Two Magnetron Models

Single HV transformer starting at serial number 1204101620

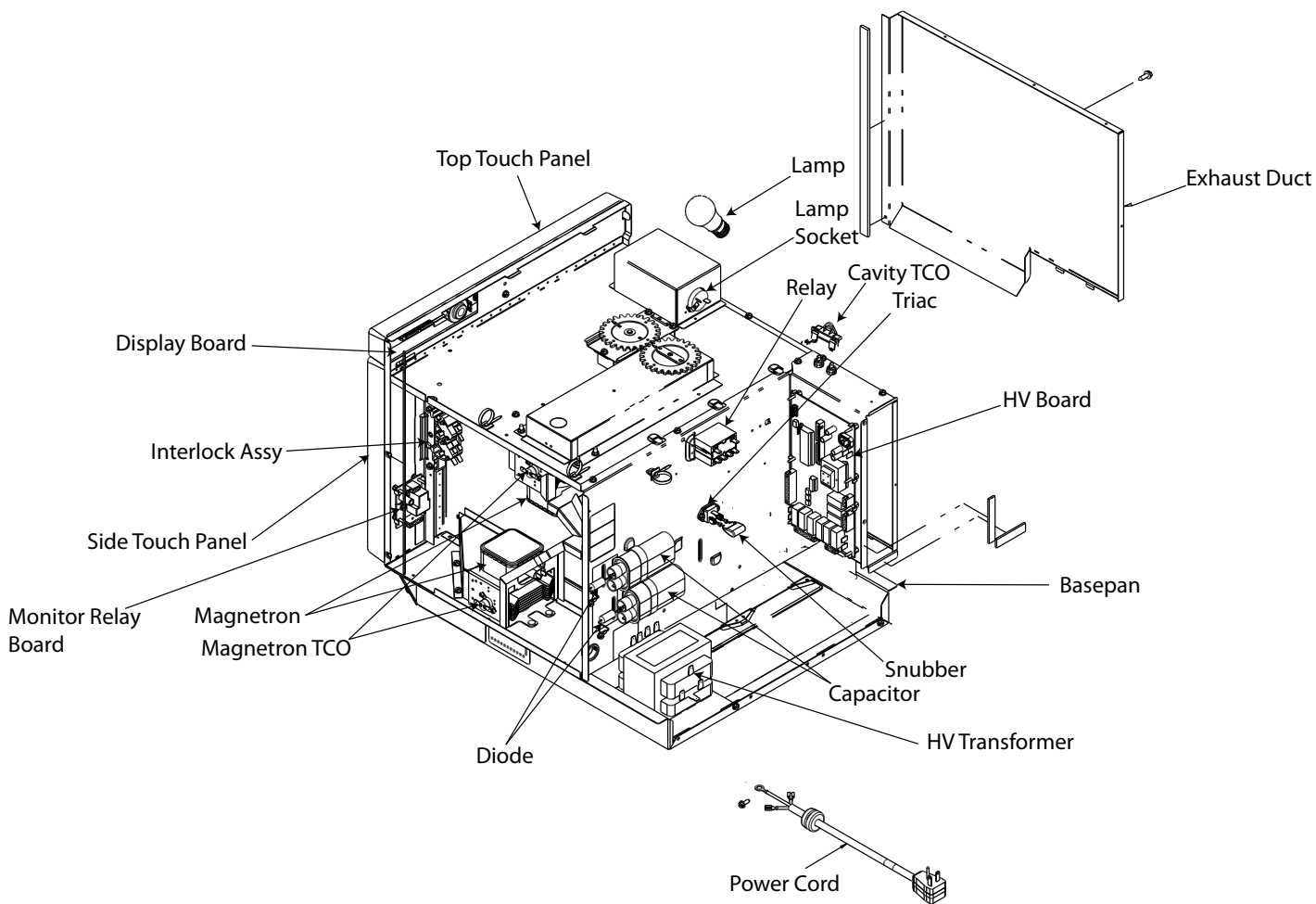

# Oven Construction

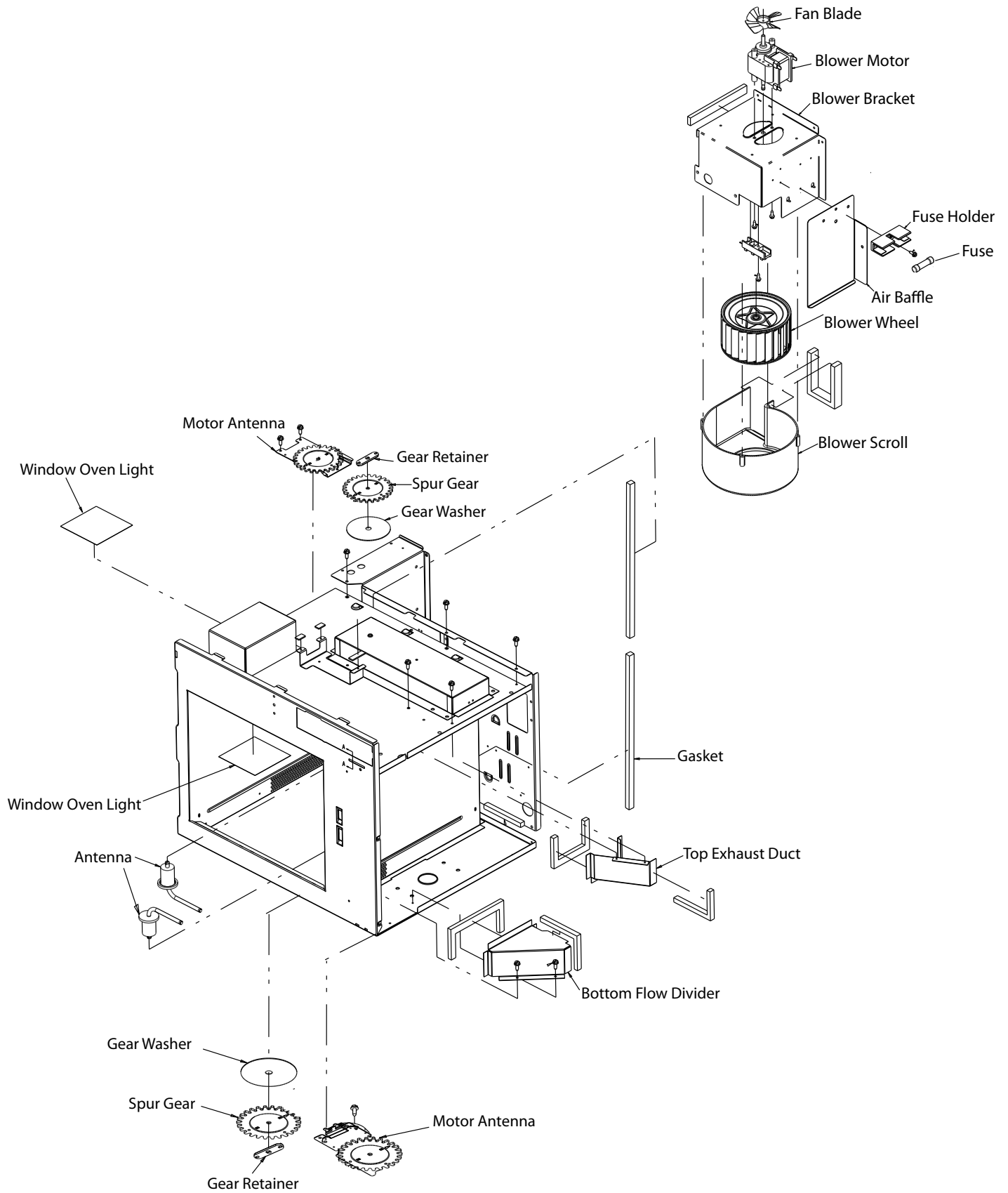

# Oven Construction Antenna Alignment

**NOTE:** Important items when re-installing antenna:

- Place nylon washer between gear and cavity.
- On 3-tube ovens, top gears must be aligned as shown below.

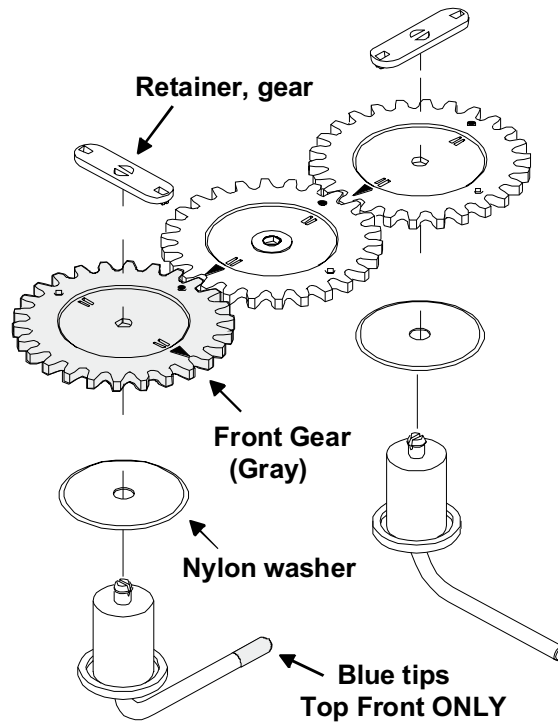

Three Tube Ovens

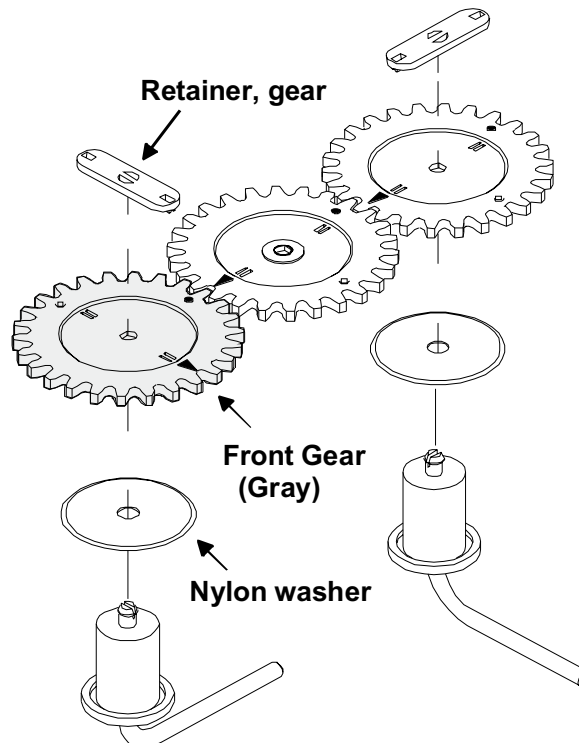

Two Tube Ovens

# Oven Performance Test

All Amana and Menumaster microwave oven power outputs are rated using the IEC705 standards. Using the IEC705 test method requires precision measurements and equipment that is not practical to be performed in the field. Using the test shown below will indicate if the oven performance is satisfactory.

## Test equipment required:

- 1000 ml test container and thermometer (ACP Power Test Bowl part # [12018801](#)).
- Digital watch / watch with a second hand for use on ovens with electromechanical timers.

## Important Notes:

- Low line voltage will cause low temperature rise / power output.
- Ovens must be on a dedicated circuit, properly grounded, and polarized. Other equipment on the same circuit may cause a low temperature rise / power output.
- This test and results are not a true IEC705 test procedures and are only intended to provide servicers with an easy means of determining if the microwave oven cooking output is correct.

## Procedure

**NOTE:** Oven cavity must be cold.

1. Fill the test container to the 1000 ml line with cool tap water.

**NOTE:** Water temperature should be approximately 60°F / 16°C

2. Using the thermometer, stir water for five to ten seconds; measure, and record the temperature (T1).
3. Place test container of water in the center of oven cavity and close door.
4. Place oven in to service mode and select service test pad 3. Magnetron will operate only.
5. Heat the water for a 33-second full power cycle.

**NOTE:** Use a digital watch or a watch with a second hand for ovens with electromechanical timers.

6. At end of the cycle, remove test container. Using the thermometer, stir water for five to ten seconds and record temperature (T2).
7. Subtract the starting water temperature (T1), from the ending water temperature (T2) to obtain the temperature rise ( $\Delta T$ ).
8. If the temperature rise ( $\Delta T$ ) meets or exceeds the minimum, the test is complete. If the temperature rise ( $\Delta T$ ) fails to meet the minimum temperature rise, test the line voltage to verify it is correct. Then repeat steps 1-6 making sure to change the water. If the temperature rise ( $\Delta T$ ) fails to meet the minimum temperature rise again the oven will require service.

**Minimum Temperature Rise at Thirty -Three (33) Seconds Run Time**

$\Delta T$ (°F)	Cooking Power Output	$\Delta T$ (°F)	Cooking Power Output	$\Delta T$ (°C)	Cooking Power Output	$\Delta T$ (°C)	Cooking Power Output
10.....	1000	20 .....	2000	5 .....	1000	11 .....	2000
11.....	1100	21 .....	2100	5.5.....	1100	11.5.....	2100
12.....	1200	22 .....	2200	6.5.....	1200	12 .....	2200
14.....	1400	24 .....	2400	7.5.....	1400	13 .....	2400
17.....	1700	25 .....	2500	9.5.....	1700	13.5.....	2500
18.....	1800	27 .....	2700	10 .....	1800	15 .....	2700
19.....	1900	30 .....	3000	10.5.....	1900	16.5.....	3000





# **7** | **RC / MRC 60 Hz Component Testing Procedures**

# Component Testing Procedures

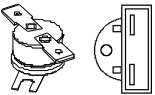

## WARNING

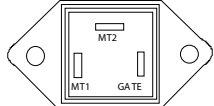
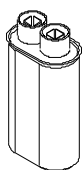
To avoid risk of electrical shock, personal injury or death; disconnect power to oven and discharge capacitor before servicing, unless testing requires power.

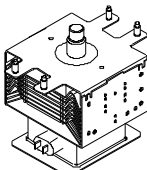
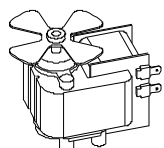
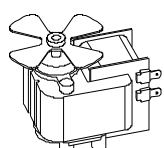
Illustration	Component	Test	Results
	Thermal cutout	Disconnect all wires from TCO. Measure resistance across terminals. Magnetron TCO.....  Cavity TCO.....	Open at 300 °F (149 °C) and closed at 257 °F (125 °C) Opens at 262 °F (128 °C)
	Diode	Discharge Capacitor  Remove diode lead from capacitor and connect ohmmeter.  Reverse leads for second test.	Infinite resistance should be measured in one direction and 50K Ω or more in the opposite direction.  NOTE: Ohmmeter must contain a battery of 6 volts minimum.
  Triac 1 (center) Triac 2 (left) Triac 3 (right)	Triac	Resistance Check Disconnect wires to triac.  Measure resistance from: MT1 to MT2..... MT1 to Gate ..... MT2 to Gate ..... All terminals to ground.....  Voltage Check Measure voltage from: MT1 to Gate	Caution - Do not operate oven with wire to terminal MT2 removed.  Infinite Approximately 60 Ω Infinite Infinite  0.8 VAC when energized. If no voltage, check H.V. board and wiring.
	Capacitor  Some units may use more than one type of capacitor. Refer to Parts Manual for correct capacitor quantity.	Discharge Capacitor  Remove wires from capacitor terminals and connect ohmmeter, set on highest resistance scale to terminals.  Also check between each terminal and capacitor case.	Between Terminals: Meter should momentarily deflect towards zero then return to over 5 M Ω. If no deflection occurs, or if continuous deflection occurs, replace capacitor.  Terminal to Case: Infinite resistance
	Snubber assembly	Disconnect wires to snubber.  Measure resistance across terminals.....	Infinite
	Magnetron	Discharge Capacitor  Remove wires from magnetron and connect ohmmeter to terminals. Also check between each terminal and ground.	Between Terminals: Less than 1 Ω  Each terminal to ground measures Infinite resistance. Note: This test is not conclusive. If oven does not heat and all other components test good replace the magnetron and retest.
	Blower motor (Prior to S/N 1107101263)	Remove all wires from motor.  Measure resistance across coil.....	Approximately 25 Ω
	Blower motor (Starting at S/N 1107101263 and after)	Remove all wires from motor.  Measure resistance between: Orange and white terminals ..... Yellow and white terminals.....	Approximately 31 Ω Approximately 29 Ω

# Component Testing Procedures



## WARNING

To avoid risk of electrical shock, personal injury or death; disconnect power to oven and discharge capacitor before servicing, unless testing requires power.

Illustration	Component	Test	Results
	<b>Auto Transformer</b> (Starting prior to S/N 1107101263) 	<b>Discharge Capacitors</b> Remove all wires from terminals.  Measure resistance from: 230 V to 0 V ..... 208 V to 0 V ..... 120 V to 0 V .....	Approximately 38 Ω Approximately 37 Ω Approximately 25 Ω
	<b>Relay board</b> (Starting at S/N 1107101263 and after)	With power applied remove violet and brown 4 pin connector from J2 connector. With door closed measure resistance from: Pin 1 to pin 4 on J2 connector..... With door open measure resistance from: Pin 1 to pin 4 on J2 connector.....	Infinite  Indicates continuity
	<b>Transformer</b> 	<b>Discharge Capacitor</b> Remove all wires from terminals.  Measure resistance from: 230 to COM ..... 208 to COM ..... 230 to Ground..... 208 to Ground..... Terminal 5 to 6..... Terminal 4 to Ground.....	Less than 1 Ω Less than 1 Ω Infinite Infinite Less than 1 Ω Refer to Tech Sheet for resistance value.
	<b>Transformer</b> 	<b>Discharge Capacitor</b> Remove all wires from terminals.  Measure resistance from: 230 to COM ..... 208 to COM ..... 230 to Ground..... 208 to Ground..... Terminal 5 to 6..... Terminal 7 to 8..... Terminal 4 to Ground.....	Less than 1 Ω Less than 1 Ω Infinite Infinite Less than 1 Ω Less than 1 Ω Refer to Tech Sheet for resistance value.
	<b>Interlock switch</b> (Prior to S/N 1107101263) 	Disconnect wires to switch.  With door open measure resistance from: Terminal 2 to 3..... Terminal 4 to 5..... Terminal 7 to 8.....  With door closed measure resistance from: Terminal 2 to 3..... Terminal 4 to 5..... Terminal 7 to 8.....	Infinite Infinite Indicates continuity  Indicates continuity Indicates continuity Infinite
	<b>Interlock switch</b> (Starting at S/N 1107101263 and after) 	Disconnect wires to switch.  With door open measure resistance from: Terminal 2 to 3..... Terminal 4 to 5..... Terminal 7 to 8.....  With door closed measure resistance from: Terminal 2 to 3..... Terminal 4 to 5..... Terminal 7 to 8.....	Infinite Infinite Infinite  Indicates continuity Indicates continuity Indicates continuity

# Component Testing Procedures

## ⚠ WARNING

To avoid risk of electrical shock, personal injury or death, disconnect power to oven and discharge capacitor before servicing, unless testing requires it.

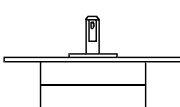
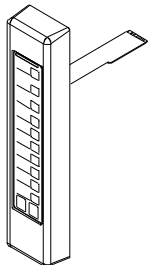
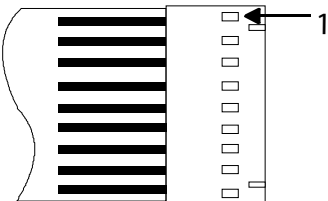
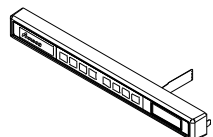
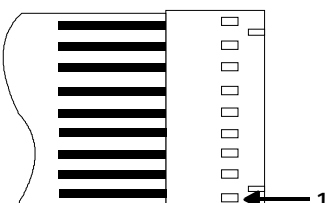
Illustration	Component	Test	Results																																							
	Antenna motor	Remove all wires from terminals.  Measure resistance from: Terminal to terminal.....	Approximately 12K $\Omega$																																							
Refer to Parts Manual for proper power cord part number.	Power cord	Measure resistance of wires.	Continuity should be indicated on each wire.  Verify polarity and grounding.																																							
	Side touch panel	Continuity is indicated as 100 $\Omega$ and below.  	<table border="1"> <thead> <tr> <th>Pad</th> <th>Trace</th> <th>Measurement</th> </tr> </thead> <tbody> <tr><td>1</td><td>3 &amp; 5</td><td>Continuity</td></tr> <tr><td>2</td><td>3 &amp; 6</td><td>Continuity</td></tr> <tr><td>3</td><td>3 &amp; 7</td><td>Continuity</td></tr> <tr><td>4</td><td>3 &amp; 8</td><td>Continuity</td></tr> <tr><td>5</td><td>3 &amp; 9</td><td>Continuity</td></tr> <tr><td>6</td><td>4 &amp; 5</td><td>Continuity</td></tr> <tr><td>7</td><td>4 &amp; 6</td><td>Continuity</td></tr> <tr><td>8</td><td>4 &amp; 7</td><td>Continuity</td></tr> <tr><td>9</td><td>4 &amp; 8</td><td>Continuity</td></tr> <tr><td>0</td><td>4 &amp; 9</td><td>Continuity</td></tr> <tr><td>Start</td><td>5 &amp; 6</td><td>Continuity</td></tr> <tr><td>Stop/Reset</td><td>6 &amp; 9</td><td>Continuity</td></tr> </tbody> </table>	Pad	Trace	Measurement	1	3 & 5	Continuity	2	3 & 6	Continuity	3	3 & 7	Continuity	4	3 & 8	Continuity	5	3 & 9	Continuity	6	4 & 5	Continuity	7	4 & 6	Continuity	8	4 & 7	Continuity	9	4 & 8	Continuity	0	4 & 9	Continuity	Start	5 & 6	Continuity	Stop/Reset	6 & 9	Continuity
Pad	Trace	Measurement																																								
1	3 & 5	Continuity																																								
2	3 & 6	Continuity																																								
3	3 & 7	Continuity																																								
4	3 & 8	Continuity																																								
5	3 & 9	Continuity																																								
6	4 & 5	Continuity																																								
7	4 & 6	Continuity																																								
8	4 & 7	Continuity																																								
9	4 & 8	Continuity																																								
0	4 & 9	Continuity																																								
Start	5 & 6	Continuity																																								
Stop/Reset	6 & 9	Continuity																																								
	Top touch panel	Removal of touch panel is required to perform test. Continuity is indicated as 100 $\Omega$ and below.  	<table border="1"> <thead> <tr> <th>Pad</th> <th>Trace</th> <th>Measurement</th> </tr> </thead> <tbody> <tr><td>Time Entry</td><td>5 &amp; 7</td><td>Continuity</td></tr> <tr><td>Power Level</td><td>5 &amp; 8</td><td>Continuity</td></tr> <tr><td>Stage</td><td>5 &amp; 9</td><td>Continuity</td></tr> <tr><td>Program Save</td><td>6 &amp; 7</td><td>Continuity</td></tr> <tr><td>Quantity</td><td>6 &amp; 8</td><td>Continuity</td></tr> <tr><td>Menu</td><td>7 &amp; 9</td><td>Continuity</td></tr> <tr><td>Hidden Pad</td><td>8 &amp; 9</td><td>Continuity</td></tr> </tbody> </table>	Pad	Trace	Measurement	Time Entry	5 & 7	Continuity	Power Level	5 & 8	Continuity	Stage	5 & 9	Continuity	Program Save	6 & 7	Continuity	Quantity	6 & 8	Continuity	Menu	7 & 9	Continuity	Hidden Pad	8 & 9	Continuity															
Pad	Trace	Measurement																																								
Time Entry	5 & 7	Continuity																																								
Power Level	5 & 8	Continuity																																								
Stage	5 & 9	Continuity																																								
Program Save	6 & 7	Continuity																																								
Quantity	6 & 8	Continuity																																								
Menu	7 & 9	Continuity																																								
Hidden Pad	8 & 9	Continuity																																								

### Display board (CPI)

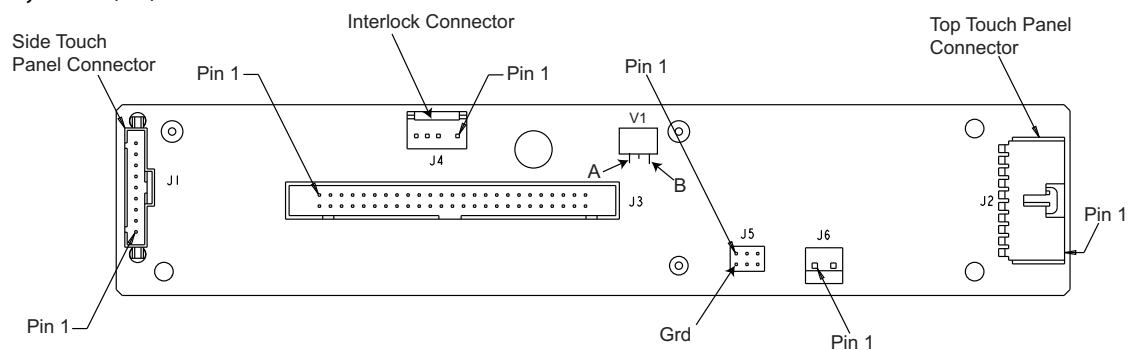

Function	Test Set-Up	Meter Setting	Probe Placement	Results
Input to Display Board	At Display Board	Volts DC	Test points V1 Pin A and J5 Pin Grd	7 - 7.5 VDC
			Test points V1 Pin B and J5 Pin Grd	5 - 5.5 VDC
			<b>Note: Unit must be in Ready Mode to detect voltage at display board</b>	If voltage is present and no display is indicated, replace display board. If no voltage is present, check wire harness connections and H.V. board.

# Component Testing Procedures (CPI Board)



## WARNING

To avoid risk of electrical shock, personal injury or death, disconnect power to oven and discharge capacitor before servicing, unless testing requires it.

H.V. board (CPI)

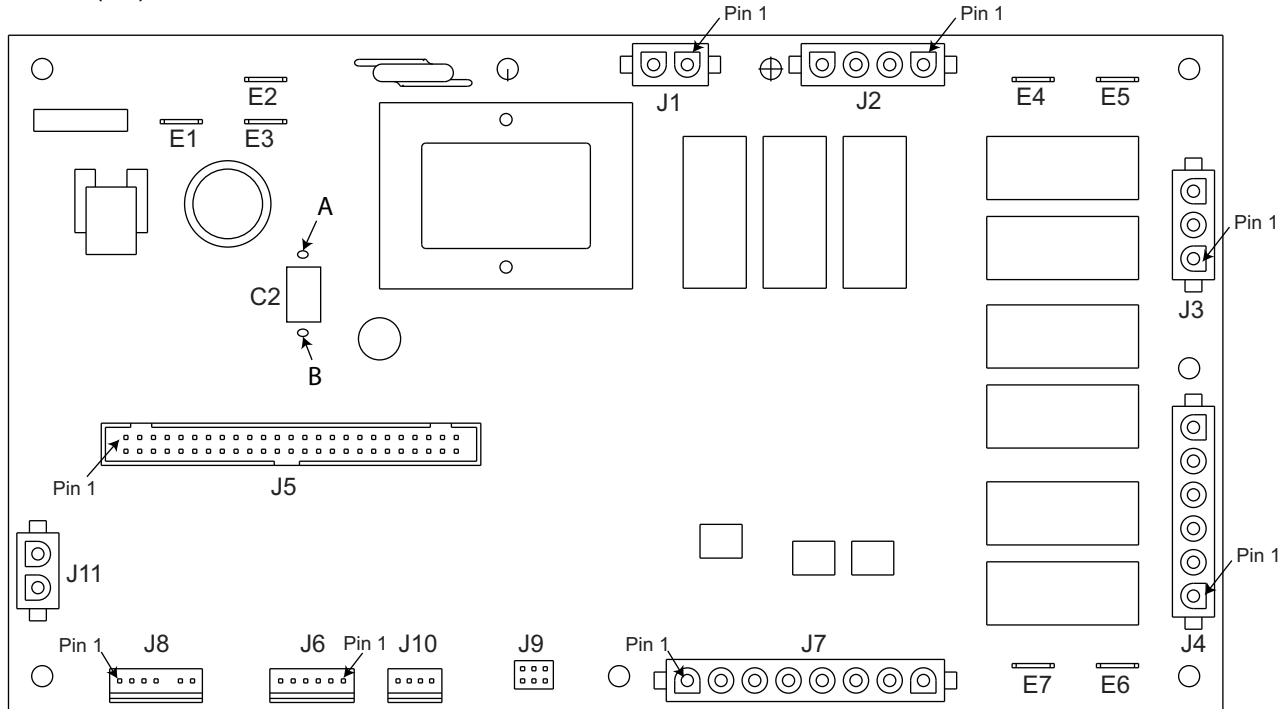

Function	Test Set-Up	Meter Setting	Probe Placement	Results
Input to H.V. board	At H.V. board	Volts	J1 pin 1 (Brown wire) & J1 pin 2 (White wire)	Line voltage
Output to Display board	At H.V. board	Volts	C2 pin A & C2 pin B	7-7.5 VDC

NOTE: For the following test, place oven in Service Test Mode .

Relay	Function	Test Set-Up	Meter Setting	Probe Placement	Results
K1 at 230 VAC line voltage	Blower motor Antenna motor Cavity light	Disconnect J2 connector	Ohms	J1 pin 1 (Brown wire) & J2 pin 4	Test mode 5 off – no continuity Test mode 5 on – < 1 Ω
K2 at 208 VAC line voltage	Blower motor Antenna motor Cavity light	Disconnect J2 connector	Ohms	J1 pin 1 (Brown wire) & J2 pin 3	Test mode 5 off – no continuity Test mode 5 on – < 1 Ω

# Component Testing Procedures (CPI Board)



## WARNING

To avoid risk of electrical shock, personal injury or death; disconnect power to oven and discharge capacitor before servicing, unless testing requires power.

### H.V. Board – Relay Test

#### Three Magnetron Models – KFC2W2, MC23MPTW2, MC23MPW2, RC30S2 and MRC30S2

Relay	Function	Test Set-Up	Meter Setting	Probe Placement	Results
K8	Magnetron 1 (Top rear) at 230 VAC	All wires connected to H.V. board	VAC	E2 (Black wire) & J4 pin 2 (Red wire)	Test mode 1 off – line voltage Test mode 1 on – 0 volts
K9	Magnetron 1 (Top rear) at 208 VAC	All wires connected to H.V. board	VAC	E2 (Black wire) & J4 pin 1 (White wire)	Test mode 1 off – line voltage Test mode 1 on – 0 volts
K4	Magnetron 2 (Top front) at 230 VAC	All wires connected to H.V. board	VAC	E5 (Red wire) & J3 pin 1 (Gray wire)	Test mode 2 off – line voltage Test mode 2 on – 0 volts
K5	Magnetron 2 (Top front) at 208 VAC	All wires connected to H.V. board	VAC	E5 (Red wire) & J3 pin 3 (Orange wire)	Test mode 2 off – line voltage Test mode 2 on – 0 volts
K6	Magnetron 3 (Bottom) at 230 VAC	All wires connected to H.V. board	VAC	J4 pin 4 (Black wire) & J4 pin 6 (Black wire)	Test mode 3 off – line voltage Test mode 3 on – 0 volts
K7	Magnetron 3 (Bottom) at 208 VAC	All wires connected to H.V. board	VAC	J4 pin 4 (Black wire) & J4 pin 5 (Brown wire)	Test mode 3 off – line voltage Test mode 3 on – 0 volts

#### Two Magnetron Models – DQ22HSI2, RC17S2, RC17SDOSI, MRC17S2, RC22S2 and WDYRC22

Relay	Function	Test Set-Up	Meter Setting	Probe Placement	Results
K8	Magnetron 1 (Top rear) at 230 VAC	All wires connected to H.V. board	VAC	E5 (Red wire) & J4 pin 2 (Red wire)	Test mode 1 off – line voltage Test mode 1 on – 0 volts
K9	Magnetron 1 (Top rear) at 208 VAC	All wires connected to H.V. board	VAC	E5 (Red wire) & J4 pin 1 (White wire)	Test mode 1 off – line voltage Test mode 1 on – 0 volts
K6	Magnetron 3 (Bottom) at 230 VAC	All wires connected to H.V. board	VAC	J4 pin 4 (Black wire) & J4 pin 6 (Black wire)	Test mode 3 off – line voltage Test mode 3 on – 0 volts
K7	Magnetron 3 (Bottom) at 208 VAC	All wires connected to H.V. board	VAC	J4 pin 4 (Black wire) & J4 pin 5 (Brown wire)	Test mode 3 off – line voltage Test mode 3 on – 0 volts

# Component Testing Procedures (Invensy Board)

## ⚠ WARNING

To avoid risk of electrical shock, personal injury or death; disconnect power to oven and discharge capacitor before servicing, unless testing requires power.

Display board (Invensy)

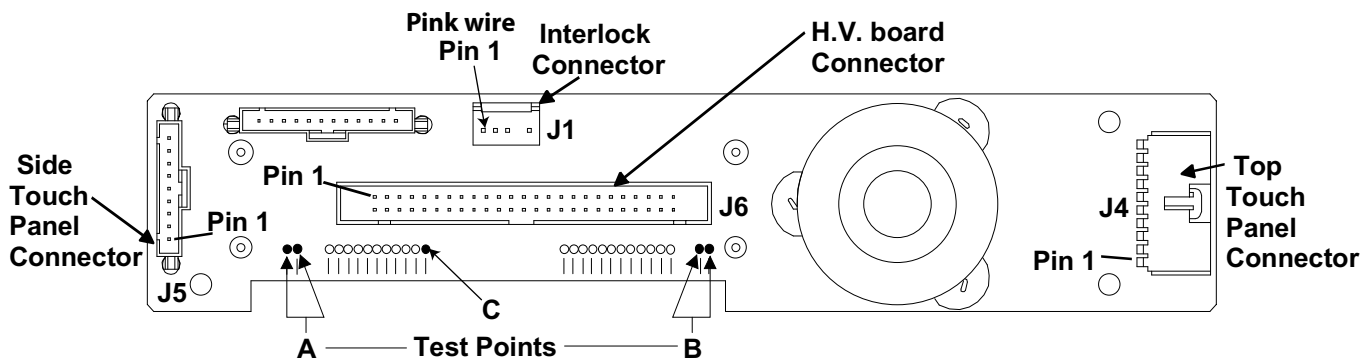

Function	Test Set-Up	Meter Setting	Probe Placement	Results
Input to Display Board	At Display Board	Volts	Test points A and B	3.0 VAC
		Volts DC	Test points C and J1 Pink wire	-25 to -30 VDC
				If voltage is present and no display is indicated, replace display board. If no voltage is present, check wire harness connections and H.V. board.

# Component Testing Procedures (Invensy Board)

## ⚠ WARNING

To avoid risk of electrical shock, personal injury or death; disconnect power to oven and discharge capacitor before servicing, unless testing requires power.

### H.V. board (Invensy)

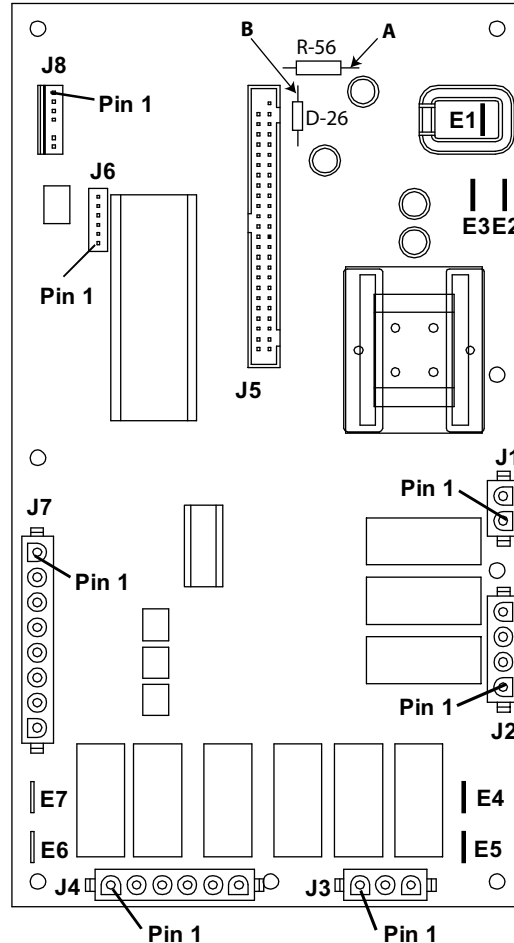

Function	Test Set-Up	Meter Setting	Probe Placement	Results
Input to H.V. board	At H.V. board	Volts	J1 pin 1 (Brown wire) & J1 pin 2 (White wire)	Line voltage
Output to display board	At H.V. board	Volts	R-56 Test point A & D-26 Test point B	- 25 to - 30VDC

**NOTE:** For the following test, place oven in Service Test Mode .

Relay	Function	Test Set-Up	Meter Setting	Probe Placement	Results
K1 at 230 VAC line voltage	Blower motor Antenna motor Cavity light	Disconnect J2 connector	Ohms	J1 pin 1 (Brown wire) & J2 pin 4	Test mode 5 off - no continuity Test mode 5 on - < 1 Ω
K2 at 208 VAC line voltage	Blower motor Antenna motor Cavity light	Disconnect J2 connector	Ohms	J1 pin 1 (Brown wire) & J2 pin 3	Test mode 5 off - no continuity Test mode 5 on - < 1 Ω

# Component Testing Procedures (Invensy Board)



## WARNING

To avoid risk of electrical shock, personal injury or death; disconnect power to oven and discharge capacitor before servicing, unless testing requires power.

### H.V. Board – Relay Test

#### Three Magnetron Models – KFC2W2, MC23MPTW2, MC23MPW2, RC30S2 and MRC30S2

Relay	Function	Test Set-Up	Meter Setting	Probe Placement	Results
K8	Magnetron 1 (Top rear) at 230 VAC	All wires connected to H.V. board	VAC	E2 (Black wire) & J4 pin 2 (Red wire)	Test mode 1 off – line voltage Test mode 1 on – 0 volts
K9	Magnetron 1 (Top rear) at 208 VAC	All wires connected to H.V. board	VAC	E2 (Black wire) & J4 pin 1 (White wire)	Test mode 1 off – line voltage Test mode 1 on – 0 volts
K4	Magnetron 2 (Top front) at 230 VAC	All wires connected to H.V. board	VAC	E5 (Red wire) & J3 pin 1 (Gray wire)	Test mode 2 off – line voltage Test mode 2 on – 0 volts
K5	Magnetron 2 (Top front) at 208 VAC	All wires connected to H.V. board	VAC	E5 (Red wire) & J3 pin 3 (Orange wire)	Test mode 2 off – line voltage Test mode 2 on – 0 volts
K6	Magnetron 3 (Bottom) at 230 VAC	All wires connected to H.V. board	VAC	J4 pin 4 (Black wire) & J4 pin 6 (Black wire)	Test mode 3 off – line voltage Test mode 3 on – 0 volts
K7	Magnetron 3 (Bottom) at 208 VAC	All wires connected to H.V. board	VAC	J4 pin 4 (Black wire) & J4 pin 5 (Brown wire)	Test mode 3 off – line voltage Test mode 3 on – 0 volts

#### Two Magnetron Models – DQ22HSI2, RC17S2, RC17SDOSI, MRC17S2, RC22S2 and WDYRC22

Relay	Function	Test Set-Up	Meter Setting	Probe Placement	Results
K8	Magnetron 1 (Top rear) at 230 VAC	All wires connected to H.V. board	VAC	E5 (Red wire) & J4 pin 2 (Red wire)	Test mode 1 off – line voltage Test mode 1 on – 0 volts
K9	Magnetron 1 (Top rear) at 208 VAC	All wires connected to H.V. board	VAC	E5 (Red wire) & J4 pin 1 (White wire)	Test mode 1 off – line voltage Test mode 1 on – 0 volts
K6	Magnetron 3 (Bottom) at 230 VAC	All wires connected to H.V. board	VAC	J4 pin 4 (Black wire) & J4 pin 6 (Black wire)	Test mode 3 off – line voltage Test mode 3 on – 0 volts
K7	Magnetron 3 (Bottom) at 208 VAC	All wires connected to H.V. board	VAC	J4 pin 4 (Black wire) & J4 pin 5 (Brown wire)	Test mode 3 off – line voltage Test mode 3 on – 0 volts

# Component Testing Procedures



## WARNING

To avoid risk of electrical shock, personal injury or death; disconnect power to oven and discharge capacitor before servicing, unless testing requires power.

### Two Magnetron Models

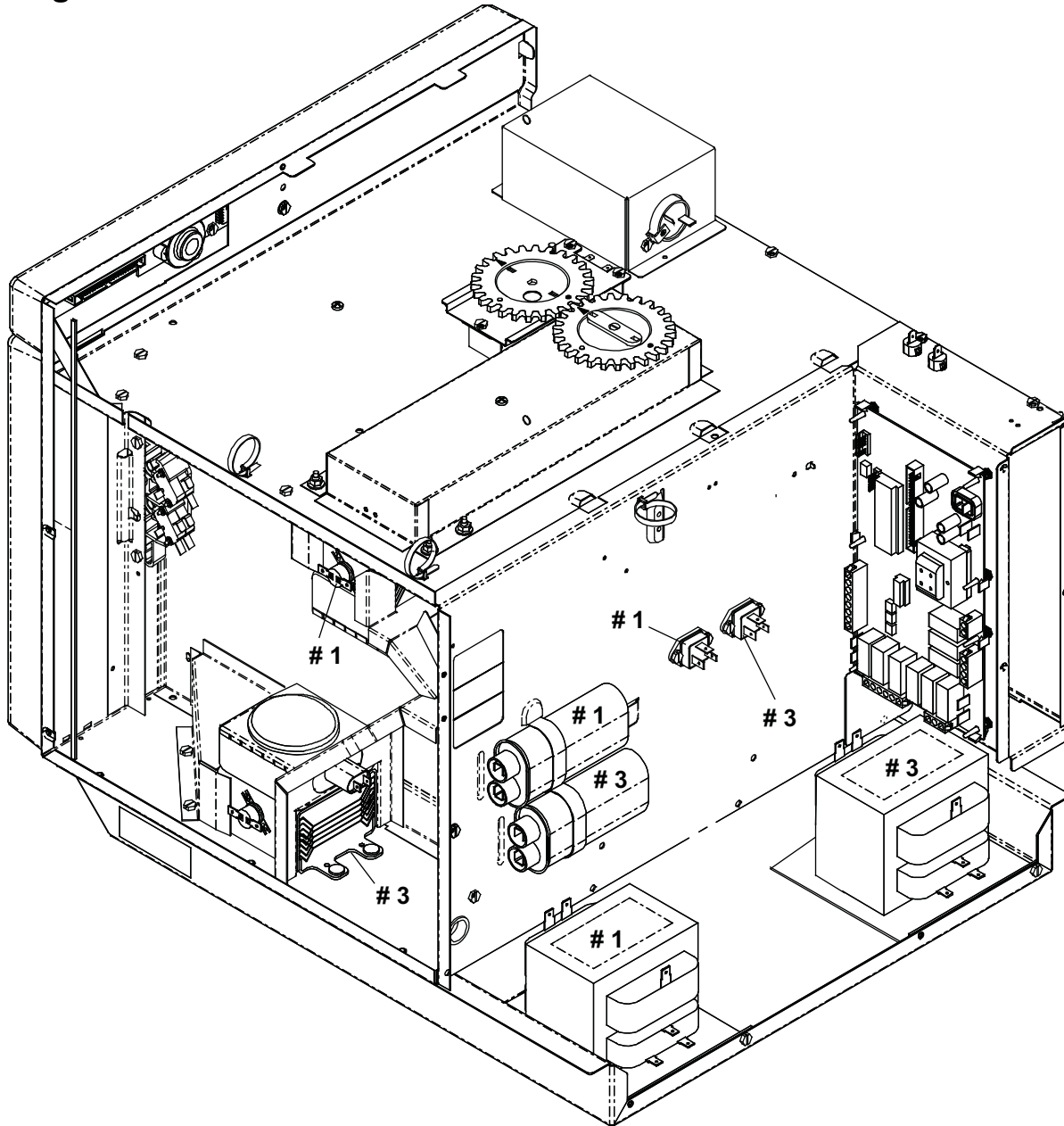

H.V. System # 1	H.V. System # 3
Top Rear Magnetron Left Transformer Top Capacitor Diode Left Triac	Bottom Magnetron Right Transformer Bottom Capacitor Diode Right Triac

# Component Testing Procedures



## WARNING

To avoid risk of electrical shock, personal injury or death; disconnect power to oven and discharge capacitor before servicing, unless testing requires power.

### Two Magnetron Models (Single Transformer)

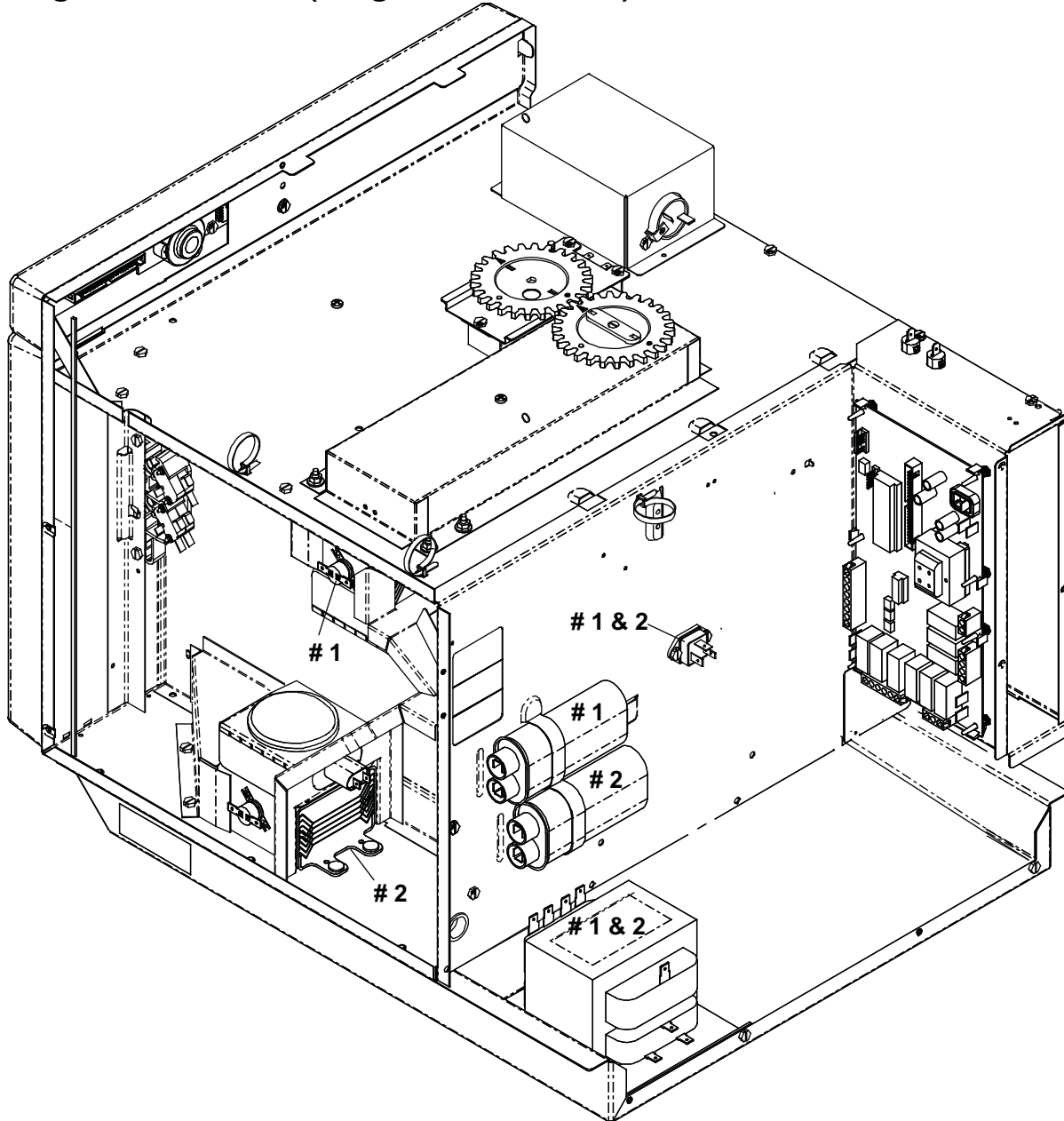

H.V. System # 1	H.V. System # 2
Top Rear Magnetron Transformer Top Capacitor Diode Triac	Bottom Magnetron Transformer Bottom Capacitor Diode Triac

# Component Testing Procedures



## WARNING

To avoid risk of electrical shock, personal injury or death; disconnect power to oven and discharge capacitor before servicing, unless testing requires power.

### Three Magnetron Models

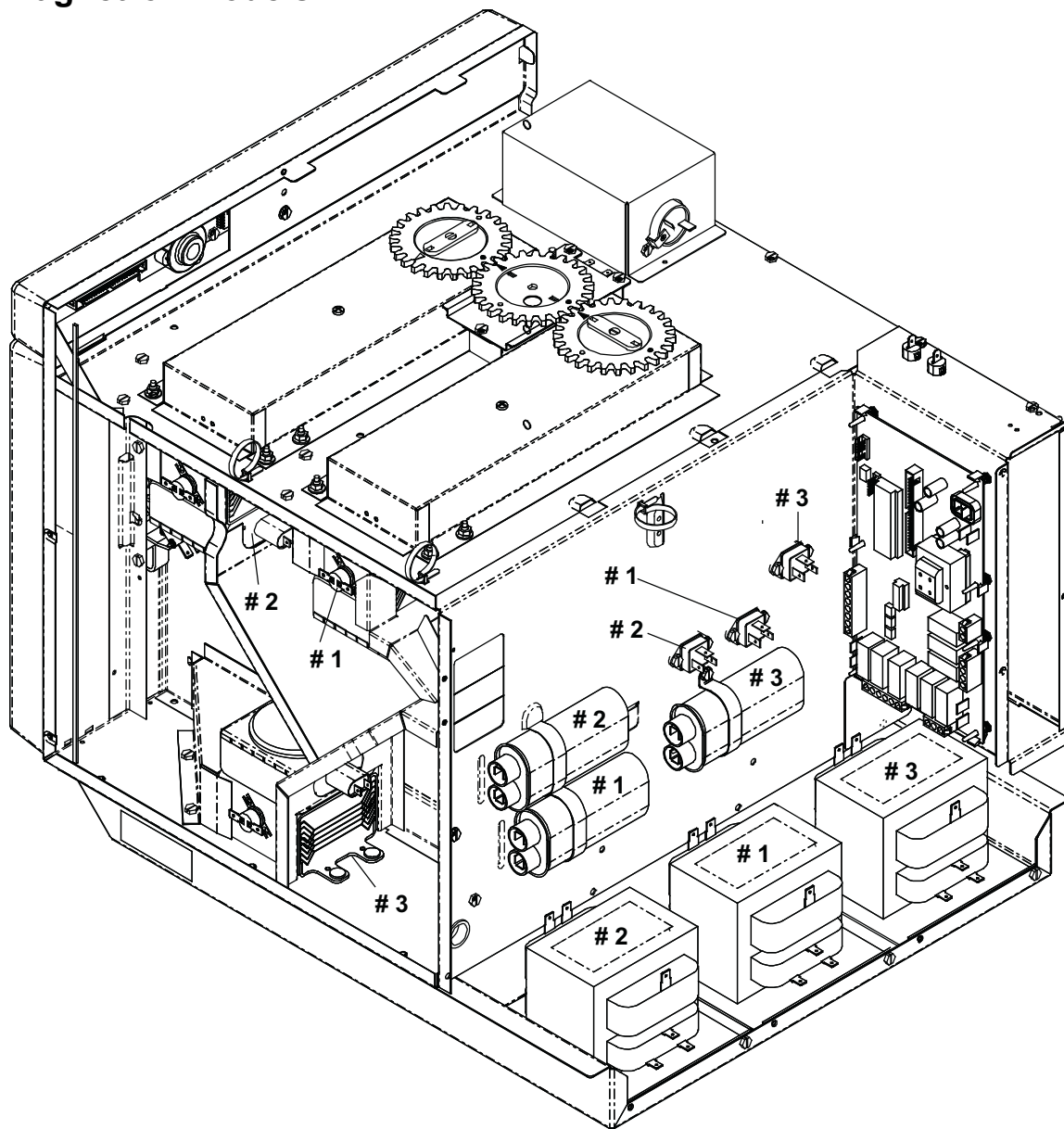

H.V. System # 1	H.V. System # 2	H.V. System # 3
Top Rear Magnetron	Top Front Magnetron	Bottom Magnetron
Center Transformer	Left Transformer	Right Transformer
Bottom Center Capacitor	Top Left Capacitor	Right Capacitor
Diode	Diode	Diode
Center Triac	Left Triac	Right Triac

# 8 | **RC / MRC 60 Hz Service Test**

# Service Test (CPI Control with Blue Display) RC / MRC / MC / DQ22HSI / KFC2

**Note:** On CPI control (Blue Display) ovens open and close door, wait until “Ready” is in the display before entering Service Test.

To Enter Service Test Mode, oven door must be closed.

NOTE: Pads will not beep when accessing Service Test Mode.

To EXIT Service Test Mode press STOP/RESET pad.



<b>Mode Name</b>	Service Mode																																								
<b>Entry</b>	Press and release Hidden Pad, 1, 3, 5, 7, 9 while in the ready mode:																																								
<b>Functional Description</b>	Main Service Mode Menu																																								
<b>Display</b>	<table border="1" style="width: 100%; text-align: center;"> <tr> <td></td><td></td><td></td><td></td><td>S</td><td>e</td><td>r</td><td>v</td><td>i</td><td>c</td><td>e</td><td></td><td>M</td><td>o</td><td>d</td><td>e</td><td></td><td></td><td></td><td></td> </tr> <tr> <td></td><td></td><td></td><td></td><td>6</td><td>0</td><td></td><td></td><td>H</td><td>Z</td><td></td><td></td><td>2</td><td>0</td><td>8</td><td></td><td>V</td><td></td><td></td><td></td> </tr> </table>					S	e	r	v	i	c	e		M	o	d	e									6	0			H	Z			2	0	8		V			
				S	e	r	v	i	c	e		M	o	d	e																										
				6	0			H	Z			2	0	8		V																									

**Note:** When operating a single HV transformer models “Pad 3” operates both Magnetron #1 & #2

**Pad 1**

<b>Mode Name</b>	Service Pad 1																																								
<b>Entry</b>	Press Pad 1 while in Service Mode																																								
<b>Functional Description</b>	Magnetron #1 shall be toggled. When on, it shall run for 62 seconds.																																								
<b>Display</b>	<table border="1" style="width: 100%; text-align: center;"> <tr> <td></td><td></td><td>M</td><td>a</td><td>g</td><td>n</td><td>e</td><td>t</td><td>r</td><td>o</td><td>n</td><td></td><td>#</td><td>1</td><td>:</td><td></td><td>O</td><td>N</td><td></td><td></td> </tr> <tr> <td></td><td></td><td>0</td><td>0</td><td>:</td><td>4</td><td>5</td><td></td><td></td><td></td><td>A</td><td>m</td><td>p</td><td>s</td><td>:</td><td></td><td>1</td><td>2</td><td></td><td></td> </tr> </table> <p><b>Note:</b> Magnetron #1 will not operate on single HV transformer models.</p>			M	a	g	n	e	t	r	o	n		#	1	:		O	N					0	0	:	4	5				A	m	p	s	:		1	2		
		M	a	g	n	e	t	r	o	n		#	1	:		O	N																								
		0	0	:	4	5				A	m	p	s	:		1	2																								

**Pad 2**

<b>Mode Name</b>	Service Pad 2																																								
<b>Entry</b>	Press Pad 2 while in Service Mode																																								
<b>Functional Description</b>	Magnetron #2 shall be toggled. When on, it shall run for 62 seconds.																																								
<b>Display</b>	<table border="1" style="width: 100%; text-align: center;"> <tr> <td></td><td></td><td>M</td><td>a</td><td>g</td><td>n</td><td>e</td><td>t</td><td>r</td><td>o</td><td>n</td><td></td><td>#</td><td>2</td><td>:</td><td></td><td>O</td><td>N</td><td></td><td></td> </tr> <tr> <td></td><td></td><td>0</td><td>0</td><td>:</td><td>4</td><td>5</td><td></td><td></td><td></td><td>A</td><td>m</td><td>p</td><td>s</td><td>:</td><td></td><td>1</td><td>2</td><td></td><td></td> </tr> </table> <p><b>Note:</b> Not applicable on two magnetron and two HV transformer models :</p>			M	a	g	n	e	t	r	o	n		#	2	:		O	N					0	0	:	4	5				A	m	p	s	:		1	2		
		M	a	g	n	e	t	r	o	n		#	2	:		O	N																								
		0	0	:	4	5				A	m	p	s	:		1	2																								

**Pad 3**

<b>Mode Name</b>	Service Pad 3																																								
<b>Entry</b>	Press Pad 3 while in Service Mode																																								
<b>Functional Description</b>	Magnetron #3 shall be toggled. When on, it shall run for 62 seconds.																																								
<b>Display</b>	<table border="1" style="width: 100%; text-align: center;"> <tr> <td></td><td></td><td>M</td><td>a</td><td>g</td><td>n</td><td>e</td><td>t</td><td>r</td><td>o</td><td>n</td><td></td><td>#</td><td>3</td><td>:</td><td></td><td>O</td><td>N</td><td></td><td></td> </tr> <tr> <td></td><td></td><td>0</td><td>0</td><td>:</td><td>4</td><td>5</td><td></td><td></td><td></td><td>A</td><td>m</td><td>p</td><td>s</td><td>:</td><td></td><td>1</td><td>2</td><td></td><td></td> </tr> </table> <p><b>Note:</b> Magnetron #1 &amp; 2 will operate together on single HV transformer models.</p>			M	a	g	n	e	t	r	o	n		#	3	:		O	N					0	0	:	4	5				A	m	p	s	:		1	2		
		M	a	g	n	e	t	r	o	n		#	3	:		O	N																								
		0	0	:	4	5				A	m	p	s	:		1	2																								

# Service Test (CPI Control with Blue Display) RC / MRC / MC / DQ22HSI / KFC2

**Pad 5**

<b>Mode Name</b>	Service Pad 5																																										
<b>Entry</b>	Press Pad 5 while in Service Mode																																										
<b>Functional Description</b>	Auxiliary Output shall be toggled.																																										
<b>Display</b>																																											
<table border="1"> <tr> <td></td><td></td><td></td><td>A</td><td>u</td><td>x</td><td>.</td><td></td><td></td><td>O</td><td>u</td><td>t</td><td>p</td><td>u</td><td>t</td><td>:</td><td></td><td>O</td><td>N</td><td></td><td></td> </tr> <tr> <td></td><td></td><td></td><td></td><td></td><td></td><td></td><td></td><td></td><td></td><td></td><td></td><td></td><td></td><td></td><td></td><td></td><td></td><td></td><td></td><td></td> </tr> </table>					A	u	x	.			O	u	t	p	u	t	:		O	N																							
			A	u	x	.			O	u	t	p	u	t	:		O	N																									

**Pad 7**

<b>Mode Name</b>	Service Pad 7																																								
<b>Entry</b>	Press Pad 7 while in Service Mode																																								
<b>Functional Description</b>	Displays Tube Hours stored in EEPROM																																								
<b>Display</b>																																									
<table border="1"> <tr> <td></td><td></td><td>M</td><td>a</td><td>g</td><td>n</td><td>e</td><td>t</td><td>r</td><td>o</td><td>n</td><td></td><td>H</td><td>o</td><td>u</td><td>r</td><td>S</td><td></td><td></td><td></td> </tr> <tr> <td></td><td></td><td></td><td></td><td></td><td></td><td>0</td><td>0</td><td>1</td><td>7</td><td>4</td><td>3</td><td></td><td></td><td></td><td></td><td></td><td></td><td></td><td></td> </tr> </table>				M	a	g	n	e	t	r	o	n		H	o	u	r	S										0	0	1	7	4	3								
		M	a	g	n	e	t	r	o	n		H	o	u	r	S																									
						0	0	1	7	4	3																														

**Pad 8**

<b>Mode Name</b>	Service Pad 8																																						
<b>Entry</b>	Press Pad 8 while in Service Mode																																						
<b>Functional Description</b>	Displays Door Cycles stored in EEPROM. Will always be a multiple of ten.																																						
<b>Display</b>																																							
<table border="1"> <tr> <td></td><td></td><td></td><td></td><td>D</td><td>o</td><td>o</td><td>r</td><td></td><td>C</td><td>y</td><td>c</td><td>l</td><td>e</td><td>s</td><td></td><td></td><td></td><td></td> </tr> <tr> <td></td><td></td><td></td><td></td><td></td><td>0</td><td>0</td><td>2</td><td>4</td><td>5</td><td>3</td><td>8</td><td>0</td><td></td><td></td><td></td><td></td><td></td><td></td> </tr> </table>						D	o	o	r		C	y	c	l	e	s										0	0	2	4	5	3	8	0						
				D	o	o	r		C	y	c	l	e	s																									
					0	0	2	4	5	3	8	0																											

**Pad 9**

<b>Mode Name</b>	Service Pad 9																																						
<b>Entry</b>	Press Pad 9 while in Service Mode																																						
<b>Functional Description</b>	Prompts user to clear service information.																																						
<b>Display</b>																																							
<table border="1"> <tr> <td></td><td></td><td>P</td><td>r</td><td>e</td><td>s</td><td>s</td><td></td><td>S</td><td>T</td><td>A</td><td>R</td><td>T</td><td></td><td>t</td><td>o</td><td></td><td></td><td></td> </tr> <tr> <td></td><td></td><td>C</td><td>l</td><td>e</td><td>a</td><td>r</td><td></td><td>s</td><td>e</td><td>r</td><td>v</td><td>.</td><td></td><td>i</td><td>n</td><td>f</td><td>o</td><td></td> </tr> </table>				P	r	e	s	s		S	T	A	R	T		t	o						C	l	e	a	r		s	e	r	v	.		i	n	f	o	
		P	r	e	s	s		S	T	A	R	T		t	o																								
		C	l	e	a	r		s	e	r	v	.		i	n	f	o																						

**Pad 0**

<b>Mode Name</b>	Service Pad 0																																						
<b>Entry</b>	Press Pad 0 while in Service Mode																																						
<b>Functional Description</b>	Prompts user that CALL SERVICE alarm is cleared.																																						
<b>Display</b>																																							
<table border="1"> <tr> <td></td><td></td><td></td><td></td><td>C</td><td>A</td><td>L</td><td>L</td><td></td><td>S</td><td>E</td><td>R</td><td>V</td><td>I</td><td>C</td><td>E</td><td></td><td></td><td></td> </tr> <tr> <td></td><td></td><td></td><td></td><td>A</td><td>l</td><td>a</td><td>r</td><td>m</td><td></td><td>C</td><td>l</td><td>e</td><td>a</td><td>r</td><td>e</td><td>d</td><td></td><td></td> </tr> </table>						C	A	L	L		S	E	R	V	I	C	E								A	l	a	r	m		C	l	e	a	r	e	d		
				C	A	L	L		S	E	R	V	I	C	E																								
				A	l	a	r	m		C	l	e	a	r	e	d																							

**NOTE: Unit must be in OFF condition  
or  
INITIAL power up mode.**

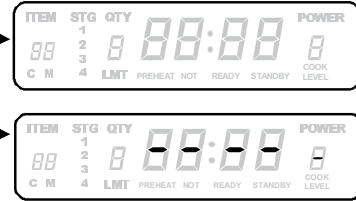

**To Enter Service Test Mode, oven door must be closed.**

**NOTE: Pads will not beep when accessing Service Test Mode.  
To EXIT Service Test Mode press STOP/RESET pad.**

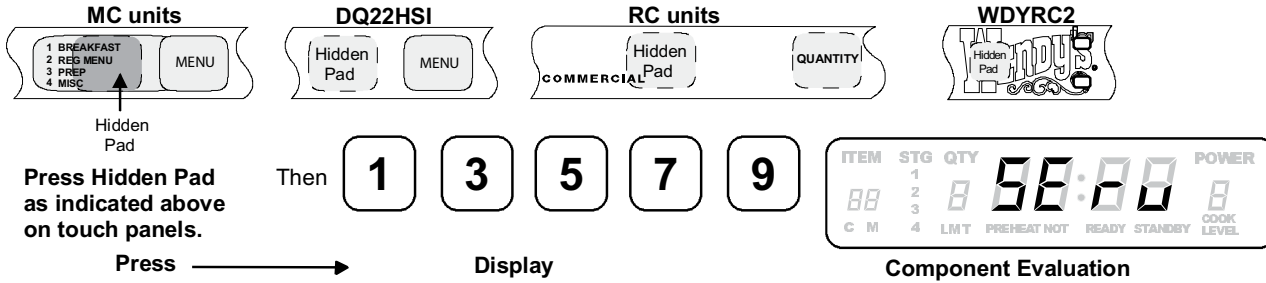

0 = Deactivated  
1 = Activated



Indicates Service Mode

**High Voltage System # 1**

Displays actual Amperage, will vary by model

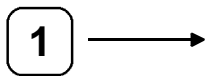

Toggles Magnetron 1 (Top Rear) ON/OFF.



Timer counts up to 62 seconds and unit shuts off.

If no Amperage, check for line voltage at H.V. transformer primary winding.  
If no voltage, check:  
• Interlock switch (secondary)  
• Triac 1  
• H.V. board (relay K8 if 230 VAC, K9 if 208 VAC, and triac 1 drive voltage T1 - G)  
• Wiring  
If voltage is present, check:  
• H.V. components and wiring.

**High Voltage System # 2**

Displays actual Amperage, will vary by model

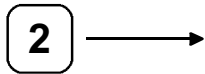

Toggles Magnetron 2 (Top Front) ON/OFF.



Timer counts up to 62 seconds and unit shuts off.

If no Amperage, check for line voltage at H.V. transformer primary winding.  
If no voltage, check:  
• Interlock switch (secondary)  
• Triac 2  
• H.V. board (relay K4 if 208 VAC, K5 if 230 VAC, and triac 2 drive voltage T1 - G)  
• Wiring  
If voltage is present, check:  
• H.V. components and wiring.

**NOTE: Not Applicable on Two Magnetron models: DQ22HSI, RC17S, RC17SD2, and RC22S.**

**High Voltage System # 3**

Displays actual Amperage, will vary by model

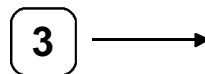

Toggles Magnetron 3 (Bottom) ON/OFF.



Timer counts up to 62 seconds and unit shuts off.

If no Amperage, check for line voltage at H.V. transformer primary winding.  
If no voltage, check:  
• Interlock switch (secondary)  
• Triac 3  
• H.V. board (relay K6 if 230 VAC, K7 if 208 VAC, and triac 3 drive voltage T1 - G)  
• Wiring  
If voltage is present, check:  
• H.V. components and wiring.

# Service Test (Invensy Control with Green Display) RC / MRC / MC / DQ22HSI / KFC2

Press →

Display

Component Evaluation

**4**

NOT ACTIVE



- This mode is NOT active with these models.

**5**

Toggles  
Blower Motor  
Antenna Motor(s)  
Cavity Light (if applicable)  
ON/OFF.



- If no fan operation, check:
- Blower motor and wheel
  - Antenna motor
  - Cavity light (if applicable)
  - H.V. board relay K1 - 230 V relay K2 - 208V
  - Wiring

**6**

NOT ACTIVE



- This mode is NOT active with these models.

**7**

Displays # of  
Magnetron Hours.

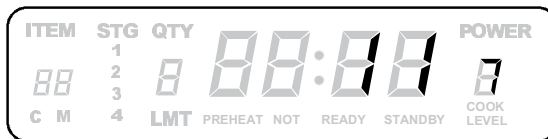

**8**

Displays # of Door Cycles  
with a 1 to 1 ratio rounded  
to the nearest ten



**9**

Clears Hours and Cycles  
(press START to activate)  
(Resets to 0).



**0**

Clears Call SErv



- Press Stop / Reset to return to normal operation

# DISPLAY DIAGNOSTICS

## CAUTION

All repairs as described in this troubleshooting section are to be performed only after the caution procedures one through eight listed below have been followed.

1. Check grounding before checking for possible causes.
2. Be careful of the high voltage circuit.
3. Discharge high voltage capacitor.
4. When checking the continuity of the switches or the high voltage transformer, disconnect one lead wire from these parts and then check continuity with the AC plug removed. To do otherwise may result in a false reading or damage to your meter.
5. Do not touch any parts of the circuitry on the P.C. Board circuit since static electric discharge may damage this control panel. Always touch yourself to ground while working on this panel to discharge any static charge in your body.
6. 208/230 VAC is present in the high voltage circuit board, power relay and primary circuit of low voltage transformer.
7. When troubleshooting, be cautious of possible electrical hazard.

## Error Codes

During operation, the display may show the following service codes:

**NOTE:** Before scheduling service for any error codes, instruct customer to unplug oven for 1 minute, reconnect power, and retest. If unit operates properly, no service call is required.

Display	Description	Corrective Action
Err1	Failed H.V. Board	Replace H.V. board.
Err2	Shorted Touch Panel Failed H.V. Board Shorted Display Board Shorted Cable HV to Display Board	Replace Touch Panel. Replace H.V. board. Replace Display Board. Replace Cable.
Err3	Failed H.V. Board	Replace H.V. board.
Err4	Failed H.V. Board	Replace H.V. board.
Err5	Shorted Touch Panel	NOTE: If Touch Panel is pressed for more than 30 seconds, this error code will appear. 1. Disconnect oven from power supply. 2. Disconnect side touch panel connector from display board (J5). 3. Reconnect oven to power supply. 4. If "Err5" reappears after 30 seconds, replace top touch panel. 5. If "Err5" does not reappear after 30 seconds, replace side touch panel.
Err6	Failed H.V. Board	Replace H.V. board.
HOT		<ul style="list-style-type: none"> <li>• Open TCO (magnetron).</li> <li>• Blower motor inoperative.</li> <li>• Restricted air filter.</li> <li>• High ambient temperature.</li> <li>• Oven operated empty or with light loads.</li> <li>• Broken or loose wire.</li> <li>• H.V. board inoperative.</li> </ul>
Door	Door Interlock Primary Switch	<ul style="list-style-type: none"> <li>• Verify latch mechanism moves freely on door.</li> <li>• Verify J1 connector on display board is properly seated.</li> <li>• Test interlock switch assembly and perform door adjustment if necessary.</li> <li>• Replace interlock switch assembly.</li> </ul>

# 9 | RC / MRC 60 Hz Wiring Diagrams / Schematics

# Wiring Diagram Sample Two Tube Models (Prior to S/N 1107101263)

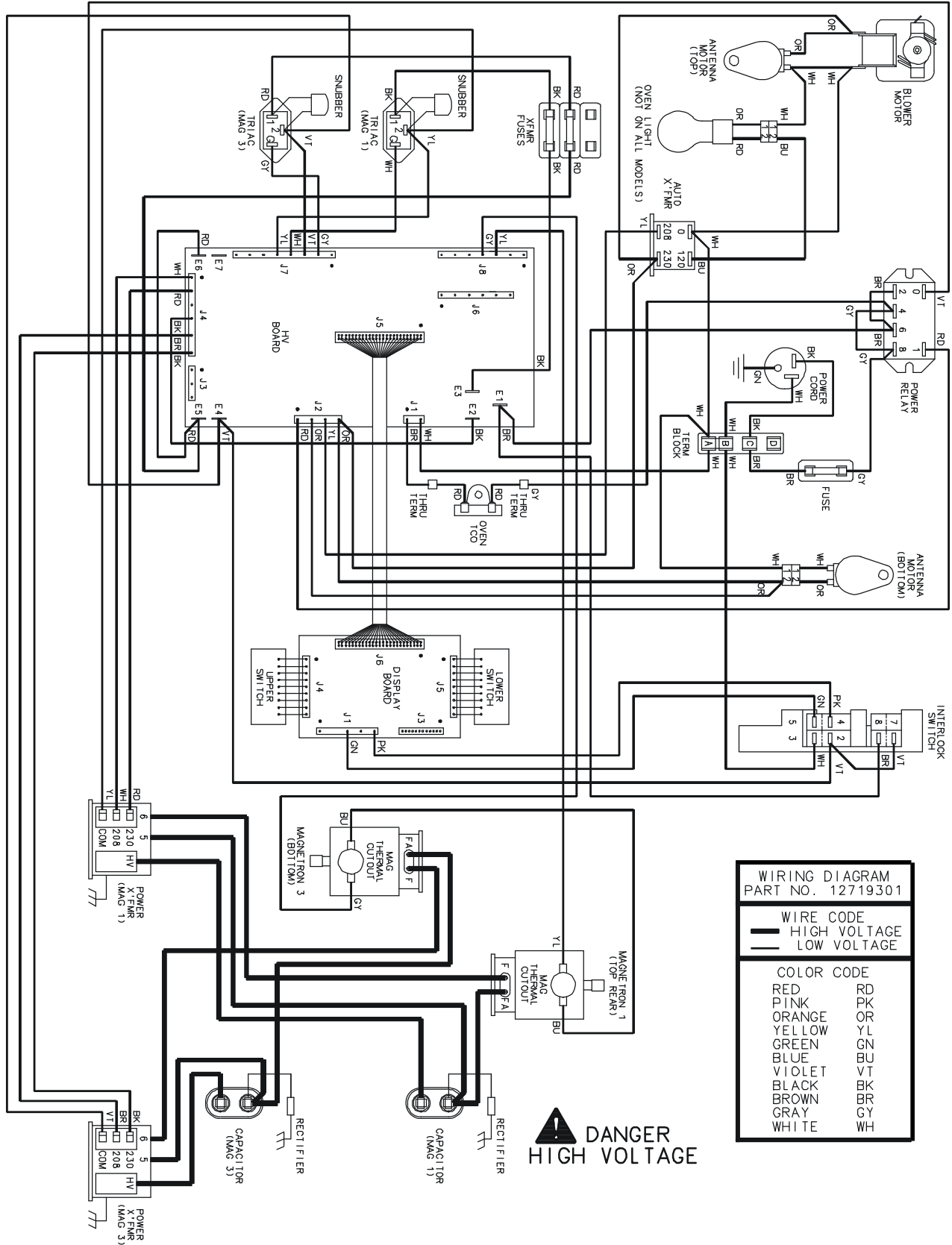

# Schematic Sample Two Tube Models (Prior to S/N 1107101263)

SCHEMATIC CONDITION: DOOR OPEN

208/230V 60Hz 3-WIRE

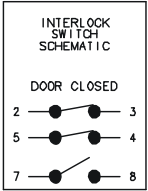
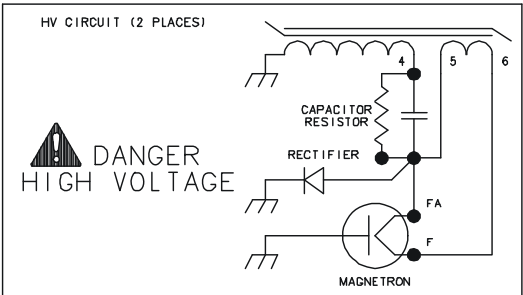
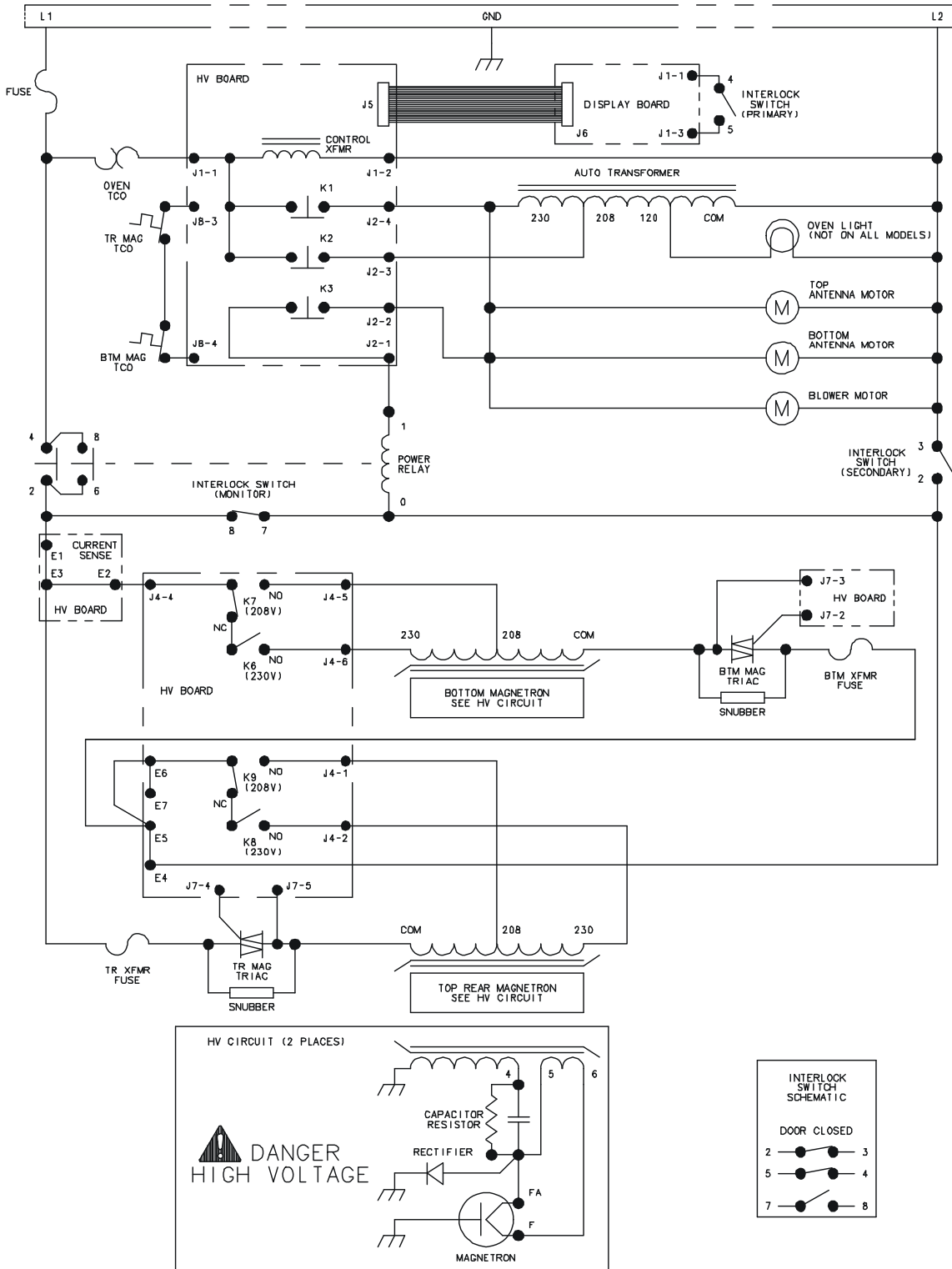

12719301



# Wiring Diagram Sample Two Tube Models (Starting at S/N 1107101263)

## Monitor Relay Board

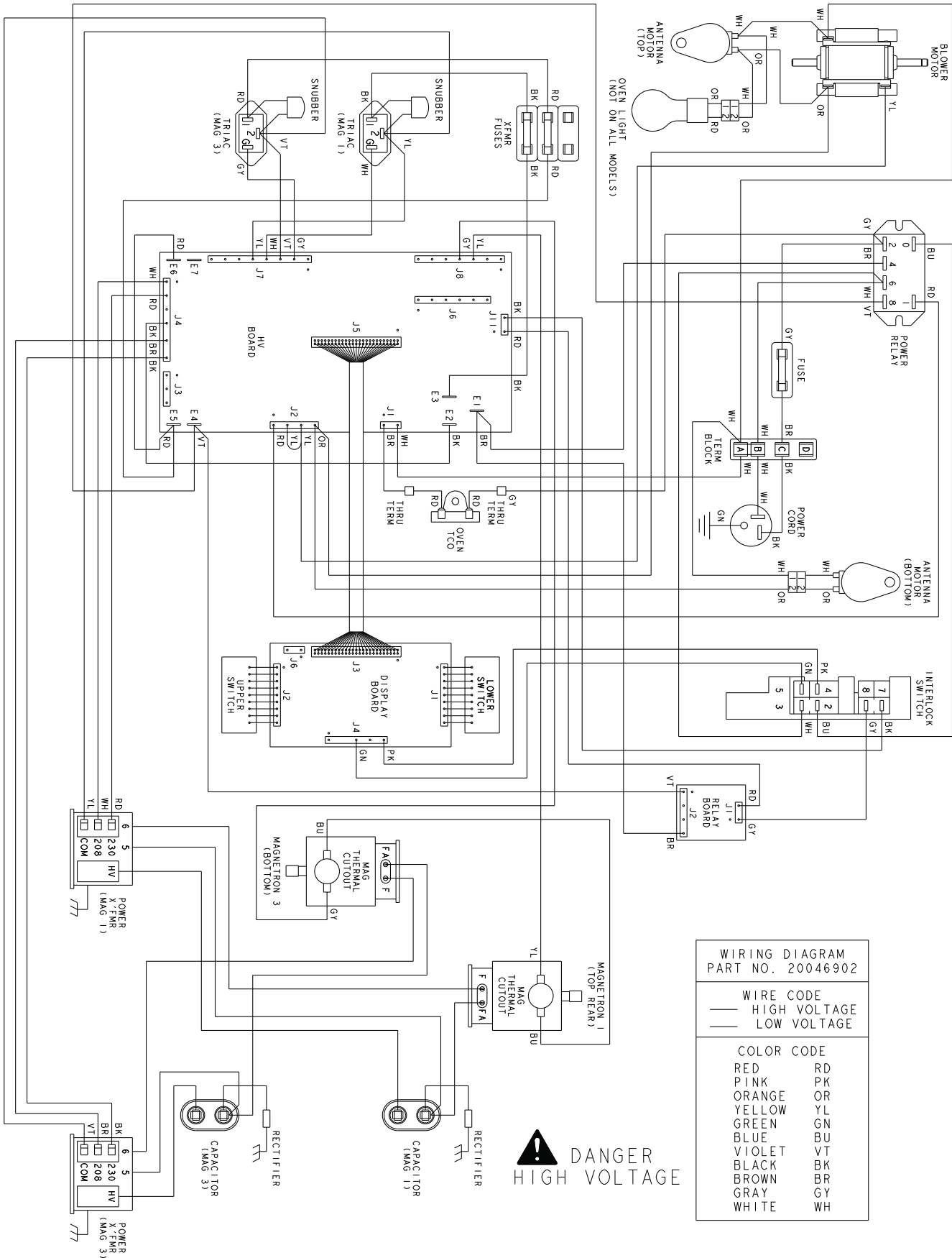

WIRING DIAGRAM  
PART NO. 20046902

WIRE CODE  
— HIGH VOLTAGE  
— LOW VOLTAGE

COLOR CODE

RED	RD
PINK	PK
ORANGE	OR
YELLOW	YL
GREEN	GN
BLUE	BU
VIOLET	VT
BLACK	BK
BROWN	BR
GRAY	GY
WHITE	WH

**⚠ DANGER HIGH VOLTAGE**



# Wiring Diagram Sample Two Tube Models (Starting at S/N 1204101620)

## Single HV Transformer

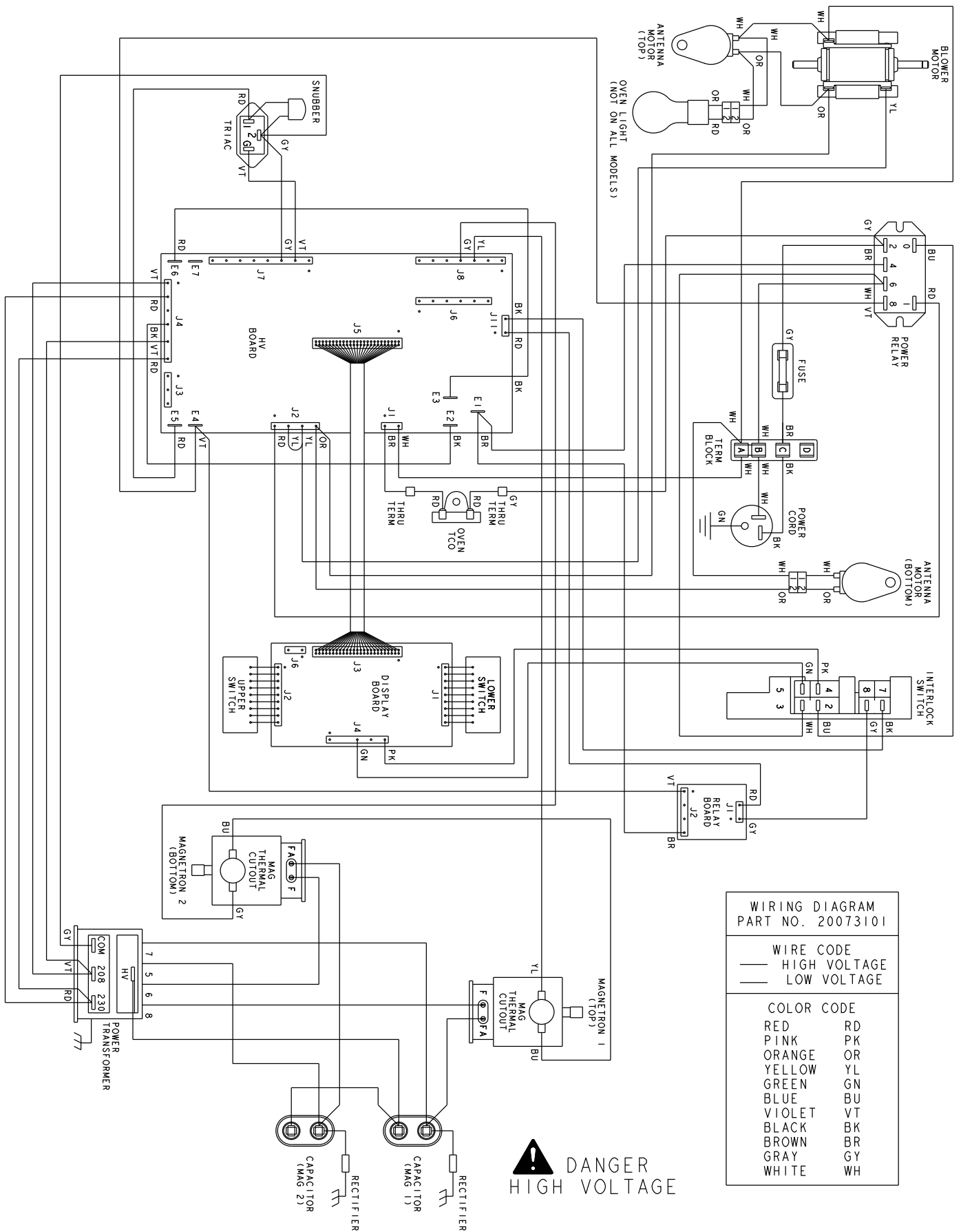

WIRING DIAGRAM  
PART NO. 20073101

WIRE CODE	
—	HIGH VOLTAGE
—	LOW VOLTAGE

COLOR CODE	
RED	RD
PINK	PK
ORANGE	OR
YELLOW	YL
GREEN	GN
BLUE	BU
VIOLET	VT
BLACK	BK
BROWN	BR
GRAY	GY
WHITE	WH

 **DANGER**  
HIGH VOLTAGE

# Schematic Sample Two Tube Models (Starting at S/N 1204101620)

## Single HV Transformer

SCHEMATIC CONDITION: DOOR OPEN

208/230V 60Hz 3-WIRE

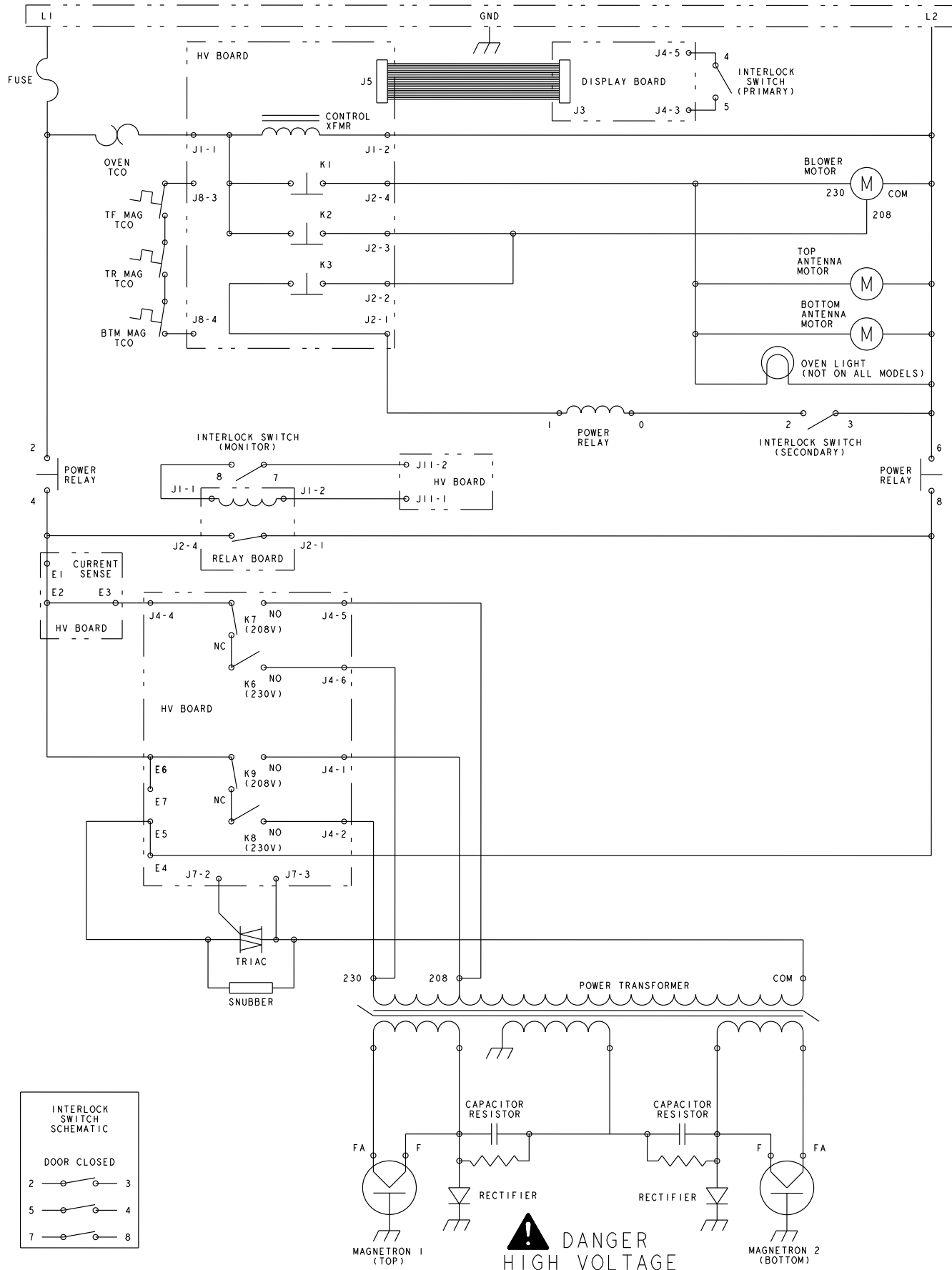

# Wiring Diagram Sample Three Tube Models (Prior to S/N 1107101263)

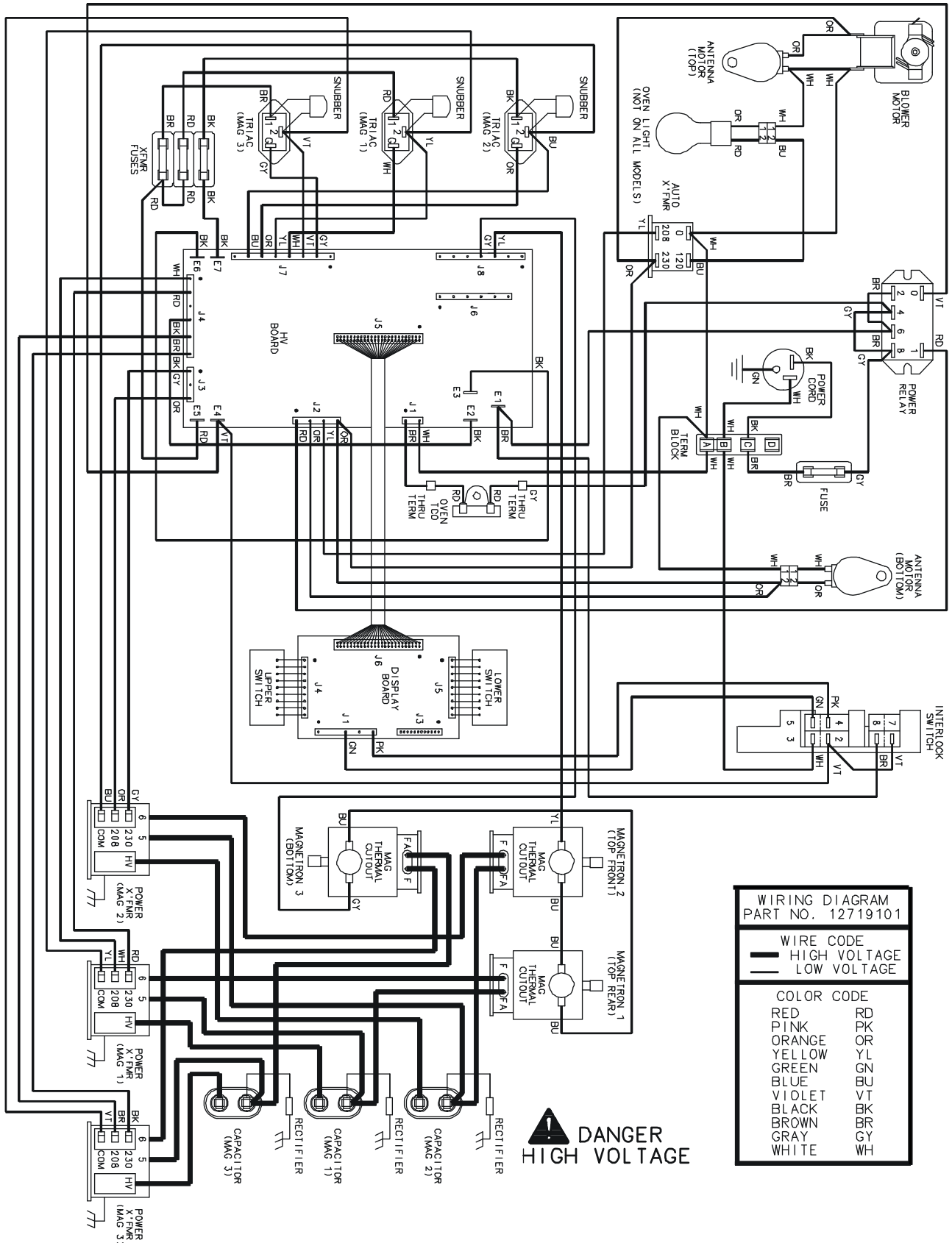

**⚠ DANGER  
HIGH VOLTAGE**

# Schematic Sample Three Tube Models (Prior to S/N 1107101263)

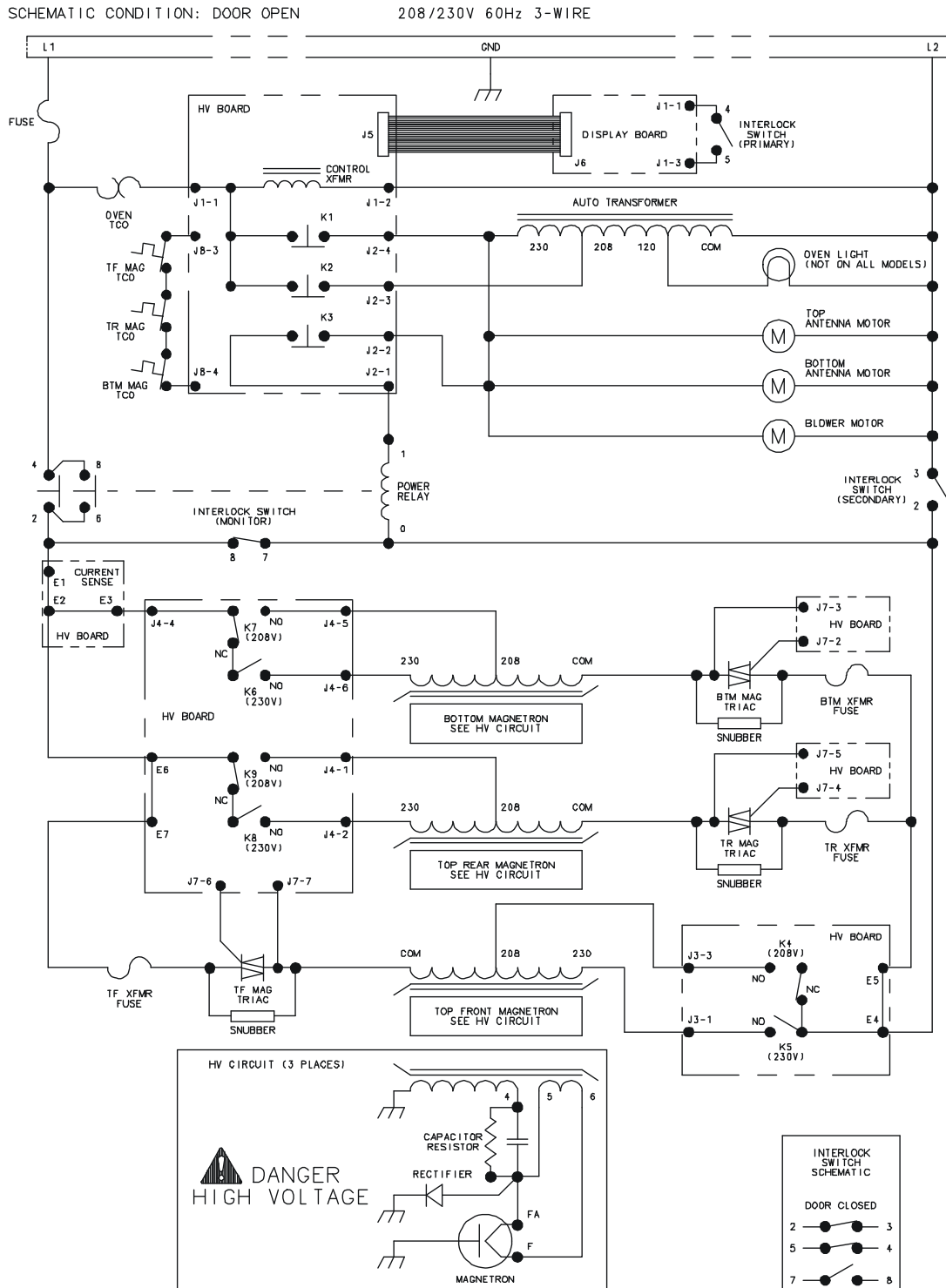

12719101



# Wiring Diagram Sample Three Tube Models (Starting at S/N 11107101263)

## Monitor Relay Board

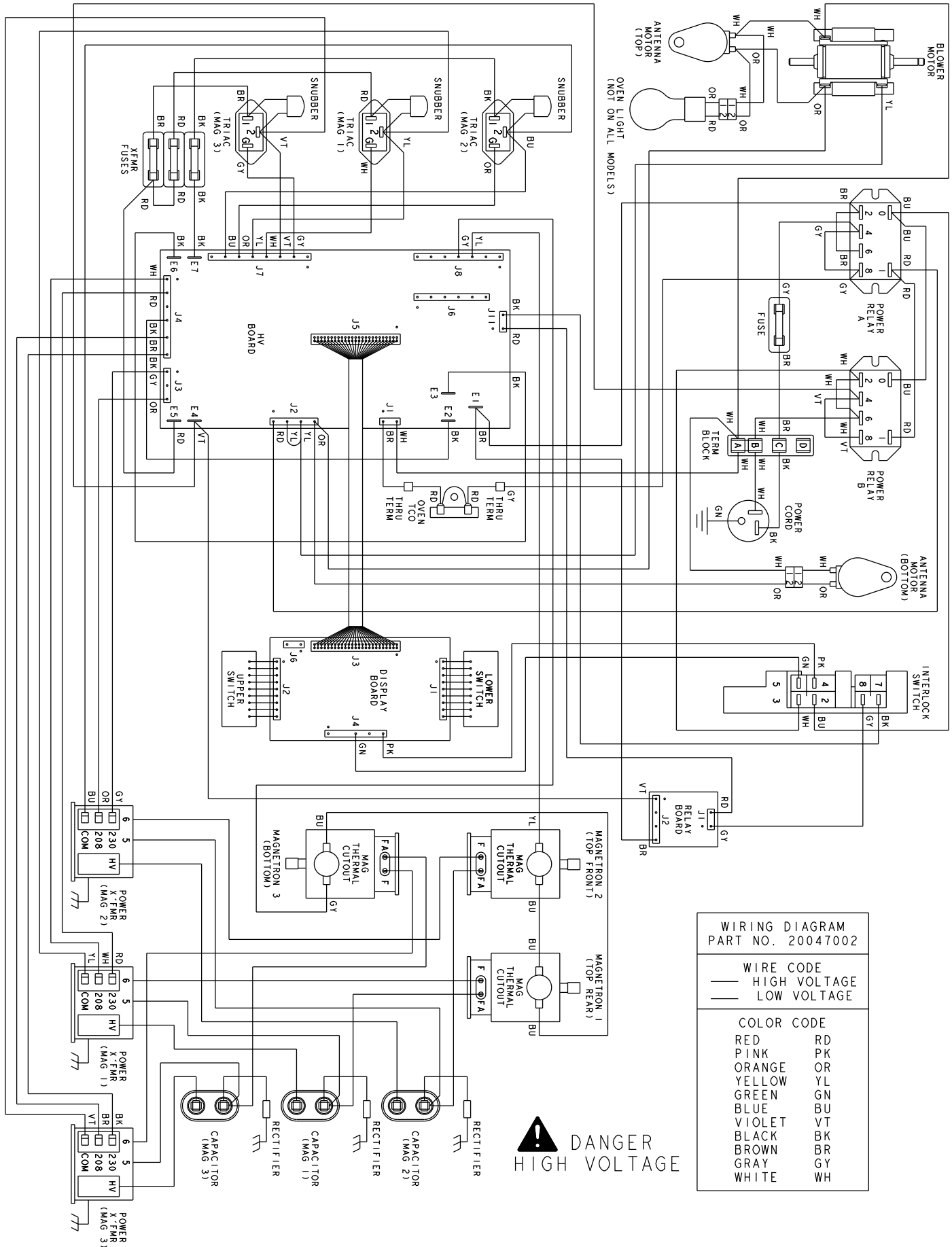

# Schematic Sample Three Tube Models (Starting at S/N 1107101263) Monitor Relay Board

SCHEMATIC CONDITION: DOOR OPEN

208/230V 60Hz 3-WIRE

