

Repair Parts List

MODEL NUMBER

LD510D

MANUFACTURING
NUMBER

P1329704M

COMMERCIAL MICROWAVE

When requesting service or ordering parts, always provide the following information:

- Product Type
- Part Number
- Model Number
- Part Description

Amana[®]
HIGH PERFORMANCE HAS A NAME™

PART OF  FOODSERVICE GROUP

December 15 2006

Section: DOOR

Model: LD510D_P1329704M

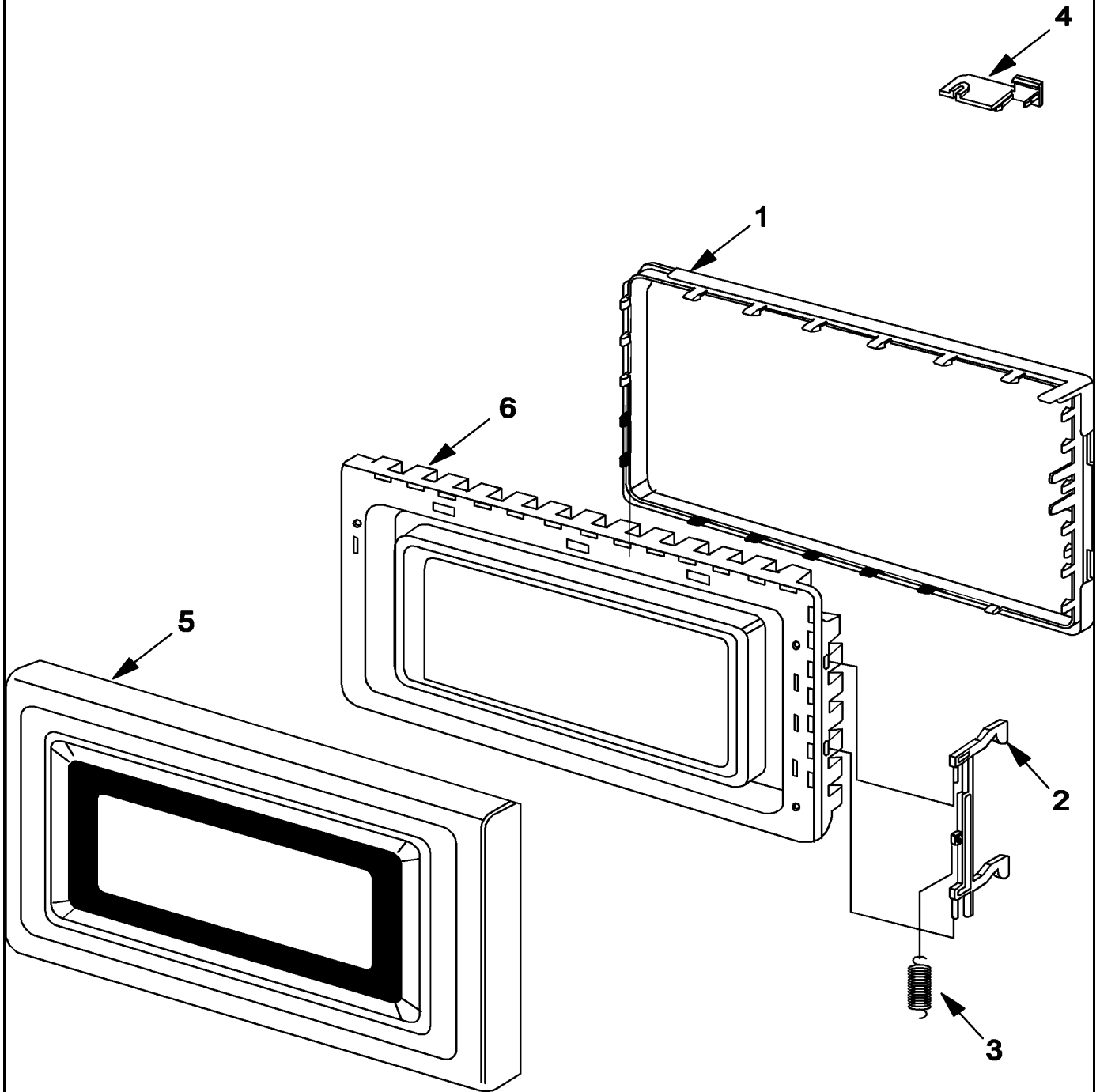

Section: DOOR

No.	Part No.	Description	Series Qty
1	R9800273	CHOKE COVER	1
2	R9800284	LATCH	1
3	R9800283	SPRING	1
4	R9900077	CAP, TOP HINGE	1
5	53001185	ASSY, OUTER DOOR	1
6	59001177	ASSY, DOOR FRAME CHOKE	1

Section: CONTROLLER

Model: LD510D_P1329704M

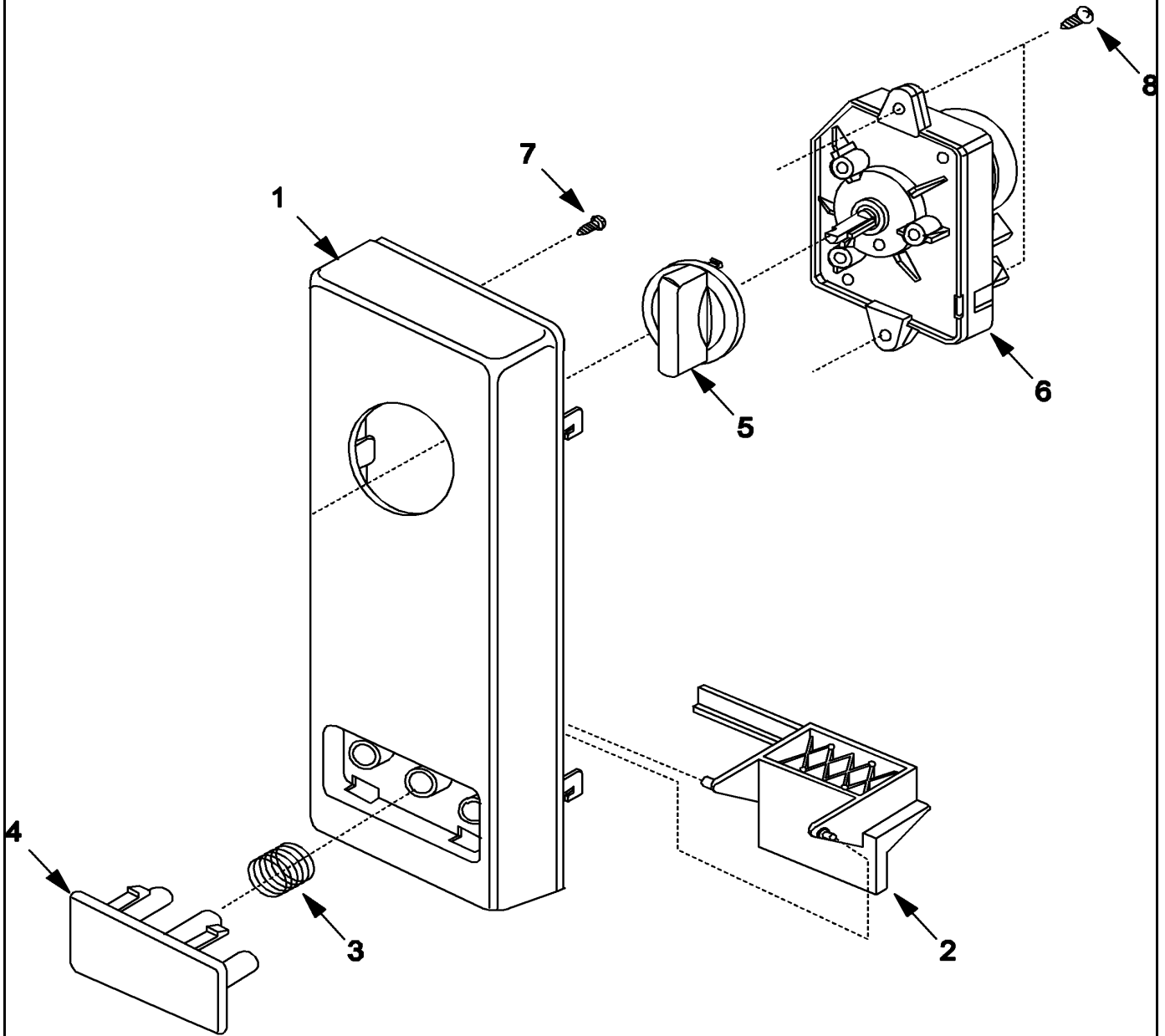

Section: CONTROLLER

No.	Part No.	Description	Series Qty
1	53001199	PANEL, CONTROL	1
2	R9800357	LEVER, RELEASE	1
3	R9800320	SPRING	1
4	59001181	BUTTON	1
5	59001182	KNOB	1
6	53001201	TIMER	1
7	R9800691	SCREW, SPECIAL D	1
8	R0654183	SCREW, TRUSS HD	2

Section: OVEN CAVITY

Model: LD510D_P1329704M

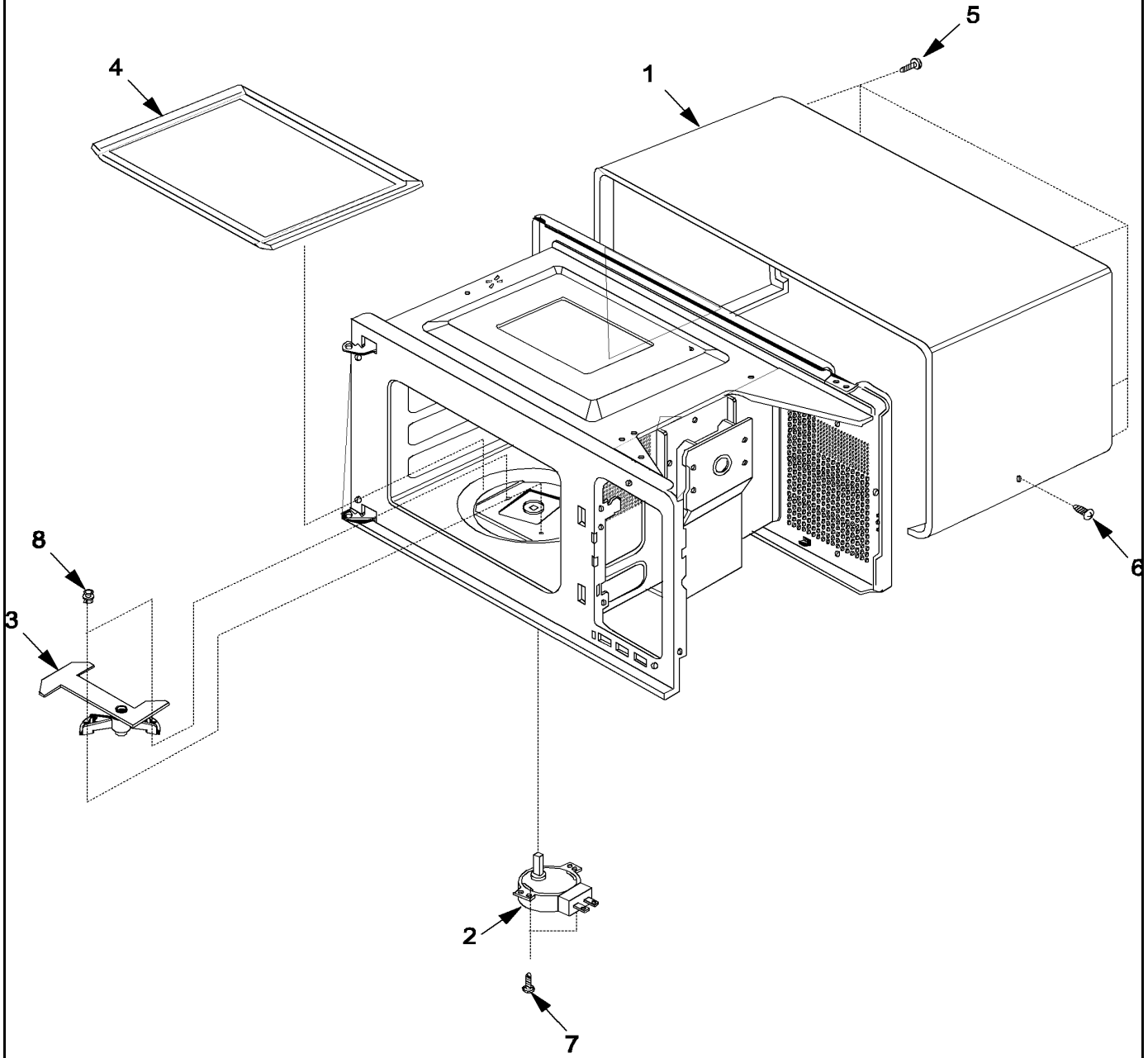

Section: OVEN CAVITY

No.	Part No.	Description	Series Qty
1	59001183	OUT CASE	1
2	59001625	MOTOR, ANTENNA 220-240V	1
3	59001190	ASSY, ANTENNA	1
4	59001194	TRAY, CERAMIC	1
5	R0131246	SCREW, TAPPING TRUSS HEAD	6
6	R9900539	SCREW, TRUSS HD	2
7	R0654180	SCREW, PAN HD	2
8	59001184	ASSY, RIVET	1

Section: LATCH BOARD

Model: LD510D_P1329704M

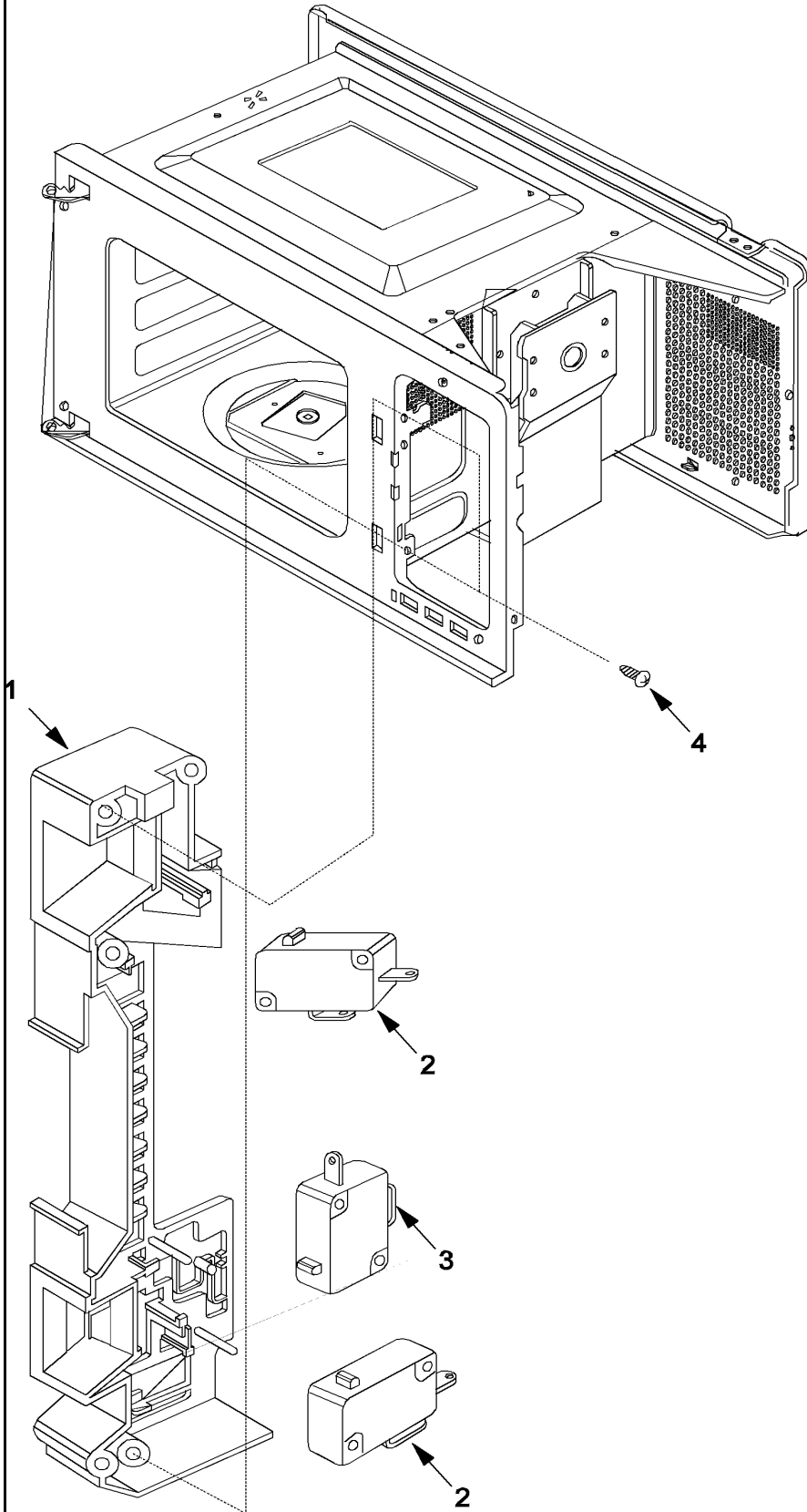

Section: LATCH BOARD

No.	Part No.	Description	Series Qty
1	R9900057	BRACKET, SWITCH	1
2	R9900519	SWITCH	2
3	R9900520	SWITCH, MONITOR	1
4	R9800691	SCREW, SPECIAL D	3

Section: BASE PLATE

Model: LD510D_P1329704M

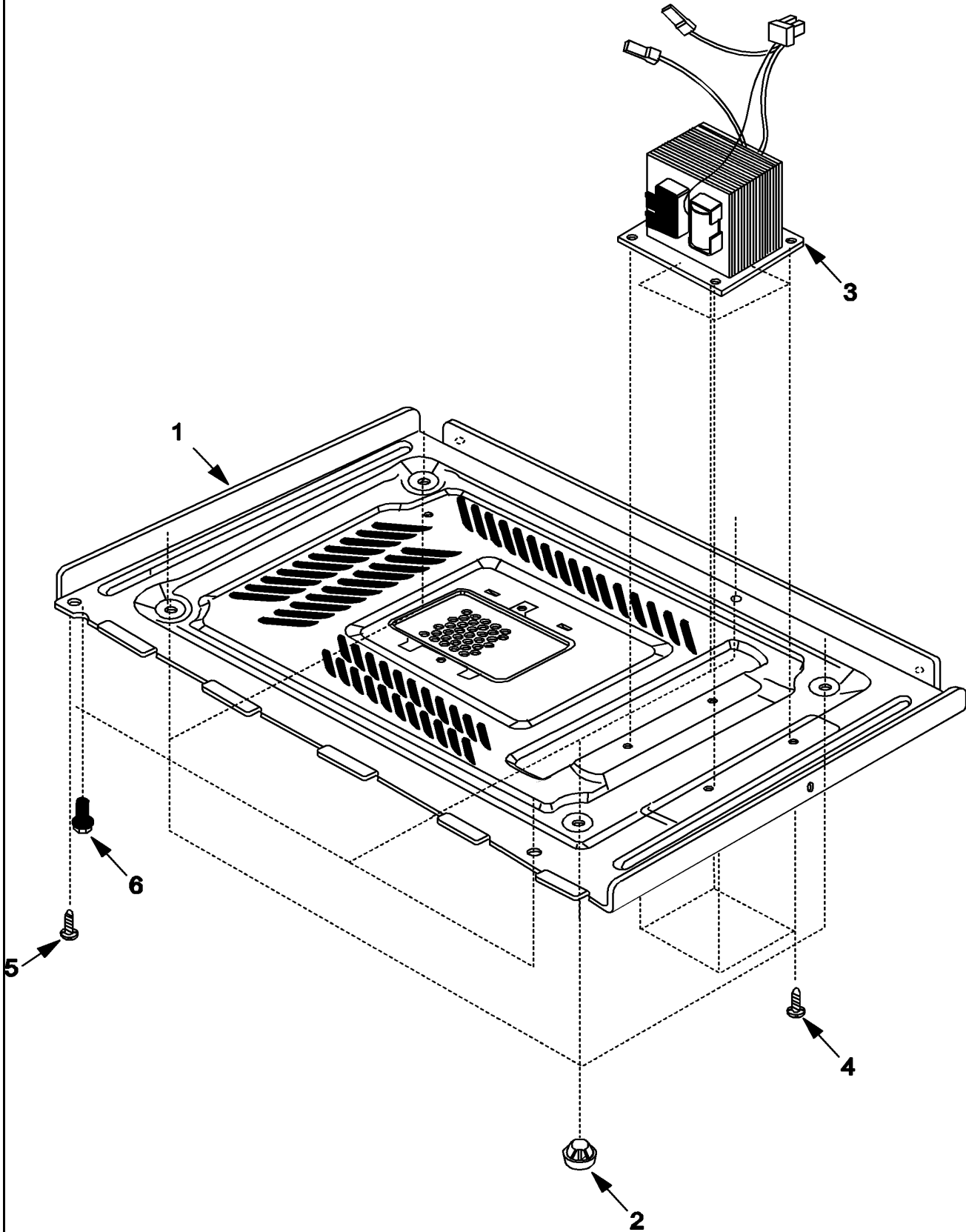

Section: BASE PLATE

No.	Part No.	Description	Series Qty
1	59001193	BASE PLATE	1
2	53001169	LEG	4
3	53001190	TRANSFORMER-HV 230V 50HZ	1
4	R0131029	SCREW, TAP TITE(S)-BINDING HEAD	4
5 N	R0654125	SCREW, TAP TITE	2
6	R0131246	SCREW, TAPPING TRUSS HEAD	1

Section: INTERIOR

Model: LD510D_P1329704M

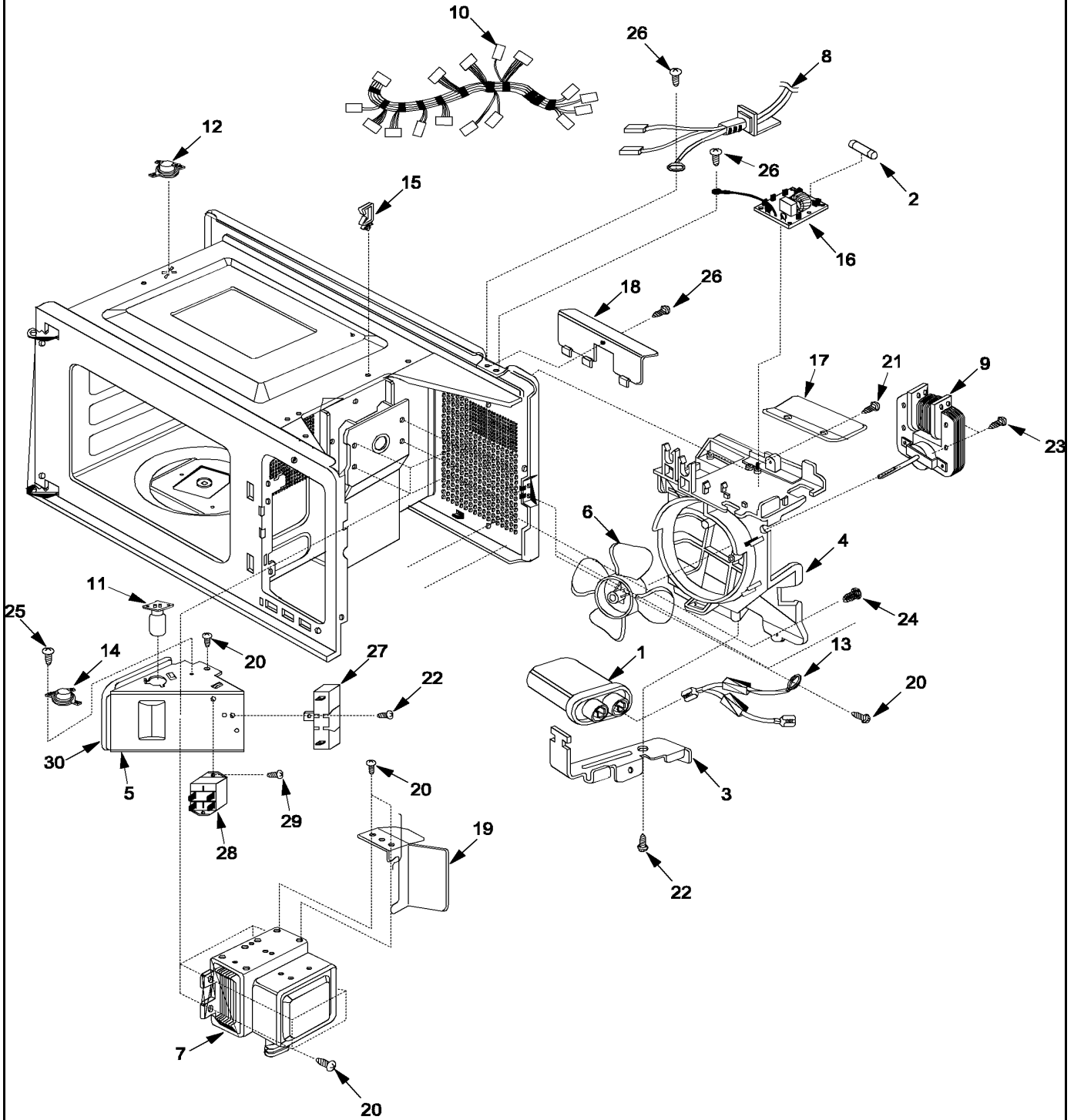

Section: INTERIOR

No.	Part No.	Description	Series Qty
1	53001191	CAPACITOR-HV	1
2	R9900522	FUSE	1
3	R0131269	BRACKET, CAPACITOR	1
4	R9900073	SHROUD, FAN MOTOR	1
5	53001192	DUCT, AIR	1
6	R9800458	BLADE, MOTOR FAN	1
7	53001193	MAGNETRON	1
8	53001194	ASSY, POWER CORD	1
9	R9900528	MOTOR, FAN	1
10	53001195	HARNESS, WIRE	1
11	R9900548	LAMP, OVEN BASELESS	1
12	59001189	THERMOSTAT, CAVITY	1
13	53001210	DIODE	1
14	R9900097	THERMO, MAGNETRON	1
15	R9800440	HOLDER- WIRING	1
16	R9900525	ASSY,FUSE BLOCK/FILTER	1
17	N R9900076	GUIDE, AIR (REAR)	1
18	59001192	COVER, POWER CORD	1
19	59001185	INSULATOR	1
20	R0131029	SCREW,TAP TITE(S)-BINDING HEAD	8
21	R9800691	SCREW, SPECIAL D	1
22	R0654183	SCREW, TRUSS HD	8
23	R9800411	SCREW, TAP TH	2
24	R0131280	SCREW	1
25	R0654030	SCREW, PAN HD S/TAP	1
26	R9900537	SCREW	3
27	R9900557	RESISTOR, MONITOR	1
28	53001197	RELAY	1
29	R0131246	SCREW, TAPPING TRUSS HEAD	1
30	R9900065	CUSHION	1

12/06

*Color Code (-)=Not Shown #=Series, Serial Prefix or Run No., N=Not Available

Section: SUPPLEMENTAL INFORMATION

No.	Part No.	Description	Series Qty
1	N 16022174	MANUAL, PARTS COMM MICROWAVES	1
2	16022150	SVC MAN, INTL COMM MICRO	1
3	N 53001214	MANUAL, USE & CARE	1

Section: WIRING INFORMATION

Model: LD510D_P1329704M

