

Service

Commercial Microwave Oven

Service Manual for
Amana®

This Base Manual covers Commercial Microwave Ovens with 120/230 V, 60 Hz. Refer to individual Technical Sheet for information on specific models. This manual includes, but is not limited to the following:

CRC18T2OG	P1323006M, P1323015M
CRC21T2RL	P1323007M, P1323017M
HDC10	P1323008M
HDC12	P1323009M
HDC18	P1323003M, P1323013M
HDC18SD	P1323004M, P1323014M
HDC21	P1323005M, P1323016M

This manual is to be used by qualified appliance technicians only. Amana does not assume any responsibility for property damage or personal injury for improper service procedures done by an unqualified person.

RS2240002
Revision 1
October 2000

Important Product Information



WARNING

Precautions to be observed before and during servicing to avoid possible exposure to excessive microwave energy.

- (A) Do not operate or allow oven to be operated with the door open.
- (B) Make the following safety checks on all ovens to be serviced before activating the magnetron or other microwave source, and make repairs as necessary:
 - Interlock operation
 - Proper door closing
 - Seal and sealing surfaces (arcing, wear, and other damage)
 - Damage to or loosening of hinges and latches
 - Evidence of dropping or abuse
- (C) Before turning on microwave power for any service test or inspection within the microwave generating compartments, check the magnetron, wave guide or transmission line, and cavity for proper alignment, integrity, and connections.
- (D) Any defective or misadjusted components in the interlock, monitor, door seal, and microwave generation and transmission systems shall be repaired, replaced, or adjusted by procedures described in this manual before oven is released to the consumer.
- (E) Check microwave leakage to verify compliance with the Federal Performance Standard should be performed on each oven prior to release to the consumer.

WIRING

Good service practice is to never route wiring over terminals and/or sharp edges. This applies to any wiring without regard to the circuit voltage. Wire insulation material and thickness is designed and regulated for electrical spacing purpose only, but cannot always be relied upon because of possible cuts and/or abrasions, which can occur during servicing.



WARNING

To avoid risk of electrical shock, injury, or death, make sure these grounding instructions are followed.

Grounding Instructions



WARNING

Do not remove grounding prong when installing grounded appliance in a home or business that does not have three wire grounding receptacle, under no condition is grounding prong to be cut off or removed. It is the personal responsibility of the consumer to contact a qualified electrician and have properly grounded three prong wall receptacle installed in accordance with appropriate electrical codes.

Should a two prong adapter plug be required temporarily it is the personal responsibility of the consumer to have it replaced with properly grounded three prong receptacle or the two prong adapter properly grounded by a qualified electrician in accordance with appropriate electrical codes.

Servicing of Grounded Products

The standard accepted color coding for grounding wires is GREEN or GREEN WITH YELLOW STRIPE. These ground leads are NOT to be used as current carrying conductors. It is extremely important that the technician replace any and all grounds prior to completion of the service call. Under no condition should ground wire be left off causing a potential hazard to technicians and consumer.

Table of Contents

Important Product Information	2	Microwave Energy Leakage Testing	
Important Information	4	Equipment	22
Important Safety Information	5	Procedure for Measuring Radiation Leakage	22
Product Information		Measurement With the Outer Case Removed	22
Antenna Blade	8	Measurement With a Fully Assembled Oven	22
Blower/Fan Assembly	8	Record Keeping and Notification	
Grease Shield	8	After Measurement	22
Door Interlock and Monitoring Switch	8	Troubleshooting	
Auto Transformer	8	Initial Power Up	23
Transformer High Voltage	8	Standby Condition	24
High Voltage Capacitor	8	Cook Condition	25
High Voltage Diode (Rectifier)	8	Disassembly	
Magnetron	8	Door Removal	26
Thermal Cutout Protectors	8	Inner Door/Window Removal	26
Touch Panels	8	Door Disassembly	26
Triac	8	Door Handle	26
Antenna Motor(s)	8	Hinge	26
Installation		Interlock Switch Assembly	27
Unpacking Oven	9	Switch Replacement / Door Adjustment	28
Oven Placement	9	Outer Case	29
Radio Interference	9	Back Panel	29
Grounding Instructions	9	Grease Shield	29
Care and Cleaning		Antenna Assembly—Top	29
Changing Oven Light Bulb	10	Antenna Motor—Top	29
Cleaning Interior, Exterior, and Door	10	Oven Tray Removal	29
Cleaning Splatter Shield	10	Antenna Assembly—Bottom	29
Cleaning Air Intake Filter	11	Antenna Motor—Bottom	30
Cleaning Discharge Air Vents	11	Touch Panel Assembly	30
Control Panel Features	12	Control Board	30
Displays		Interlock Switch Assembly	30
Cooking Methods	13	Magnetron Cutout (TCO)	30
Cooking Displays	13	Triac	30
Programming Displays	13	Diodes	30
Operation		Magnetron	30
Interrupting Operation	14	Cavity Thermal Cutout Replacement	31
Canceling Mistakes	14	Fuse	31
Operating Preprogrammed Pads	14	Blower Wheel and Motor	31
Using X2 Pad	14	Fan Blade	31
Manual Time Entry	14	Auto Transformer	31
Programming Instructions		High Voltage Transformer	32
Memory Pads	15	Capacitor	32
Multiple Cooking Stages	15	Power Cord	32
X2 Quantity Feature	15	Lamp Receptacle	32
User Options	16	Replacing Oven Lamp	32
Component Testing Procedures	17	Component Location	
Test Modes		Figure 1	33
Power Test	21	Figure 2	34
		Figure 3	35

Important Information

Pride and workmanship go into every product to provide our customers with quality products. It is possible, however, that during its lifetime a product may require service. Products should be serviced only by a qualified service technician who is familiar with the safety procedures required in the repair and who is equipped with the proper tools, parts, testing instruments and the appropriate service manual. **REVIEW ALL SERVICE INFORMATION IN THE APPROPRIATE SERVICE MANUAL BEFORE BEGINNING REPAIRS.**

Important Notices for Consumers and Servicers

WARNING

To avoid risk of serious injury or death, repairs should not be attempted by an unauthorized personnel, dangerous conditions (such as exposure to electrical shock) may result.

CAUTION

Amana will not be responsible for any injury or property damage from improper service procedures. If performing service on your own product, assume responsibility for any personal injury or property damage which may result.

To locate an authorized servicer, please consult your telephone book or the dealer from whom you purchased this product. For further assistance, please contact:

CONSUMER AFFAIRS DEPT.
AMANA REFRIGERATION, INC.
AMANA, IOWA 52204

**OR
CALL**

1-319-622-5511
and ask for
Consumer Affairs

If outside the United States contact:

AMANA
ATTN: CONSUMER AFFAIRS DEPT
2800 220th Trail
AMANA, IOWA 52204, USA
Telephone: (319) 622-5511
Facsimile: (319) 622-2180
TELEX: 4330076 AMANA
CABLE: "AMANA", AMANA, IOWA, USA

Recognize Safety Symbols, Words, and Labels

DANGER

DANGER - Immediate hazards which **WILL** result in severe personal injury or death.

WARNING

WARNING - Hazards or unsafe practices which **COULD** result in severe personal injury or death.

CAUTION

CAUTION - Hazards or unsafe practices which **COULD** result in minor personal injury or product or property damage.

Important Safety Information



CAUTION

Do not become exposed to radiation from the microwave generator or other parts conducting microwave energy.

Basic design of this microwave oven makes it an inherently safe device to both use and service. However, there are some precautions which should be followed when servicing microwave oven to maintain this safety. These are as follows:

1. Always operate unit from an adequately grounded outlet. Do not operate on a two-wire extension cord.
2. Before servicing unit (if unit is operable) perform microwave leakage test.
3. Oven should never be operated if door does not fit properly against seal, hinge/hinge bearings are damaged or broken; choke is damaged, (pieces missing, etc.); or any other visible damage can be noted. Check choke area to ensure that this area is clean and free of all foreign matter. If any above problems occur take the following steps:
 - Tell the user not to operate the oven.
 - Contact Amana immediately.
4. If oven operates with door open and produces microwave energy, take the following steps:
 - Tell the user not to operate the oven.
 - Contact Amana immediately.
5. Always have oven disconnected when outer case is removed except when making "live" tests called for in the service manual. Do not reach into equipment area while unit is energized. Make all connections for the test and check them for tightness before plugging cord into outlet.
6. Always ground capacitors on magnetron filter box and H.V. capacitor with an insulated-handle screwdriver before working in high voltage area of equipment compartment. Some types of failures will leave a charge in capacitors and the discharge could cause a reflex action which could make you injure yourself.
7. In the area of the transformer, capacitor, diode, and magnetron there is HIGH VOLTAGE. When unit is operating, keep area clean and free of anything which could possibly cause an arc or ground, etc.
8. **DO NOT** for any reason defeat interlock switches, there is no valid reason for this action at any time; nor will it be condoned by Amana.
9. Microwave oven should never be operated with:
 - Any components removed and/or bypassed
 - Any of the safety interlocks are found to be defective
 - Any of the seal surfaces are defective, missing, or damaged
10. To ensure that unit does not emit excessive microwave leakage and to meet Department of Health and Human Services guidelines check oven for microwave leakage using Narda Model 8100, 8200, Holaday HI1500, HI1501, or Simpson 380M leakage monitor as outlined in instructions. Maximum leakage level allowed is 4mw/cm².
11. If servicer encounters an emission reading over 4mw/cm², servicer is to cease repair and contact Amana Service Department immediately for further direction. Amana will contact the proper government agency upon verification of test results.
12. Install or locate this equipment **ONLY** in accordance with the installation instructions in this manual.
13. Some products such as whole eggs and sealed containers – for example, closed glass jars – may explode and **SHOULD NOT** be **HEATED** in this equipment.
14. Use this equipment **ONLY** for its intended use as described in this manual. Do not use corrosive chemicals or vapors in this equipment. This type of equipment is specifically designed to heat or cook. It is not designed for industrial or laboratory use.
15. As with any equipment, **CLOSE SUPERVISION** is necessary when used by **CHILDREN**.
16. **DO NOT** operate this equipment if it has a damaged cord or plug, if it is not working properly, or if it has been damaged or dropped.
17. This equipment, including power cord, must be serviced **ONLY** by qualified service personnel. Special tools are required to service equipment. Contact nearest authorized service facility for examination, repair, or adjustment.
18. **DO NOT** cover or block any openings on the equipment.
19. **DO NOT** store this equipment outdoors. **DO NOT** use this product near water – for example, near a kitchen sink, in a wet basement, or near a swimming pool, and the like.
20. **DO NOT** immerse cord or plug in water.
21. Keep cord **AWAY** from **HEATED** surfaces.
22. **DO NOT** let cord hang over edge of table or counter.

Important Safety Information

CAUTION

To avoid personal injury or property damage, observe the following:

1. Briskly stir or pour liquids before heating with microwave energy to prevent spontaneous boiling or eruption. Do not overheat. If air is not mixed into a liquid, liquid can erupt in oven or after removal from oven.
2. Do not deep fat fry in oven. Fat could overheat and be hazardous to handle.
3. Do not cook or reheat eggs in shell or with an unbroken yolk using microwave energy. Pressure may build up and erupt. Pierce yolk with fork or knife before cooking.
4. Pierce skin of potatoes, tomatoes, and similar foods before cooking with microwave energy. When skin is pierced, steam escapes evenly.
5. Do not operate equipment without load or food in oven cavity.
6. Use only popcorn in packages designed and labeled for microwave use. Popping time varies depending on oven wattage. Do not continue to heat after popping has stopped. Popcorn will scorch or burn. Do not leave oven unattended.
7. Do not use regular cooking thermometers in oven. Most cooking thermometers contain mercury and may cause an electrical arc, malfunction, or damage to oven.
8. Do not heat baby bottles in oven.
9. Do not use metal utensils in oven.
10. Never use paper, plastic, or other combustible materials that are not intended for cooking.
11. When cooking with paper, plastic, or other combustible materials, follow manufacturer's recommendations on product use.
12. Do not use paper towels which contain nylon or other synthetic fibers. Heated synthetics could melt and cause paper to ignite.
13. Do not heat sealed containers or plastic bags in oven. Food or liquid could expand quickly and cause container or bag to break. Pierce or open container or bag before heating.
14. To avoid pacemaker malfunction, consult physician or pacemaker manufacture about effects of microwave energy on pacemaker.

PRECAUTIONS TO AVOID POSSIBLE EXPOSURE TO EXCESSIVE MICROWAVE ENERGY

- a. **DO NOT** attempt to operate this oven with the door open since open-door operation can result in harmful exposure to microwave energy. It is important not to defeat or tamper with the safety interlocks.
- b. **DO NOT** place any object between the oven front face and the door or allow soil or cleaner residue to accumulate on sealing surfaces.
- c. **DO NOT** operate the oven if it is damaged. It is particularly important that the oven door close properly and that there is no damage to the: (1) door (bent), (2) hinges and latches (broken or loosened), (3) door seal and sealing surface.
- d. The oven should **NOT** be adjusted or repaired by anyone except properly qualified service personnel.

Important Safety Information



Recognize this symbol as a SAFETY message



WARNING

When using electrical equipment, basic safety precautions should be followed to reduce the risk of burns, electrical shock, fire, or injury to persons.

1. **READ** all instructions before using equipment.
2. **READ AND FOLLOW** the specific “**PRECAUTIONS TO AVOID POSSIBLE EXPOSURE TO EXCESSIVE MICROWAVE ENERGY**”.
3. This equipment **MUST BE GROUNDED**. Connect only to properly GROUNDED outlet. See “**GROUNDED INSTRUCTIONS**”.
4. Install or locate this equipment **ONLY** in accordance with the installation instructions in this manual.
5. Some products such as whole eggs and sealed containers – for example, closed glass jars – may explode and **SHOULD NOT** be **HEATED** in this oven.
6. Use this equipment **ONLY** for its intended use as described in this manual. Do not use corrosive chemicals or vapors in this equipment. This type of oven is specifically designed to heat or cook. It is not designed for industrial or laboratory use.
7. As with any equipment, **CLOSE SUPERVISION** is necessary when used by **CHILDREN**.
8. **DO NOT** operate this equipment if it has a damaged cord or plug, if it is not working properly, or if it has been damaged or dropped.
9. This equipment, including power cord, must be serviced **ONLY** by qualified service personnel. Special tools are required to service equipment. Contact nearest authorized service facility for examination, repair, or adjustment.
10. **DO NOT** cover or block filter or other openings on equipment.
11. **DO NOT** store this equipment outdoors. **DO NOT** use this product near water – for example, near a kitchen sink, in a wet basement, or near a swimming pool, and the like.
12. **DO NOT** immerse cord or plug in water.
13. Keep cord **AWAY** from **HEATED** surfaces.
14. **DO NOT** let cord hang over edge of table or counter.
15. See door cleaning instructions in “Care and Cleaning” section.
16. **For commercial use only.**



CAUTION

To reduce the risk of fire in the oven cavity:

- a. **DO NOT** overcook food. Carefully attend equipment if paper, plastic, or other combustible materials are placed inside the oven to facilitate cooking.
- b. Remove wire twist-ties from paper or plastic bags before placing bag in oven.
- c. **KEEP** oven **DOOR CLOSED**, turn oven off, and disconnect the power cord, or shut off power at the fuse or circuit breaker panel, if materials inside the oven should ignite. Fire may spread if door is opened.
- d. **DO NOT** use the cavity for storage. **DO NOT** leave paper products, cooking utensils, or food in the cavity when not in use.

Product Information

Antenna Blade

Distributes microwave energy throughout the cavity.

Blower/Fan Assembly

Circulates cooling air throughout the microwave oven compartment and cavity.

Grease Shield

Covers and protects the antenna blade assembly.

Door Interlock and Monitoring Switch

NOTE: When the line fuse is open, Interlock Switch Assembly must be replaced.

Interlock switch assembly mounts behind oven cavity front bulkhead. Switches are actuated by the door hooks.

Monitoring switch (contacts COM and NC) is actuated by the top door hook.

The primary interlock switch (contacts COM and NO) is actuated by the top door hook.

The logic switch (contacts COM and NO) is actuated by the bottom door hook.

The secondary interlock switch (contacts COM and NO) is actuated by the bottom door hook.

If a malfunction occurs in the primary interlock when door opens, current will flow through the monitor switch causing the oven fuse to open.

If a faulty door interlock switch has allowed current through the monitor switch, the switch assembly must be replaced (see interlock switch testing) before replacing fuse.



DANGER

To avoid severe personal injury or death avoid contacting any high voltage parts. The capacitors are at high voltage (4000 volt) potential and it is extremely important that they be grounded before handling.

Auto Transformer

Auto transformer in this unit provides a voltage of 120, 208, or 230 VAC.

Transformer High Voltage

High voltage transformer is used in this unit, which supplies high voltage A.C. for operation of the magnetron tube.

High Voltage Capacitor

Doubles the A.C. output voltage from the high voltage transformer.

High Voltage Diode (Rectifier)

Is connected at the output side of the high voltage capacitor. It changes voltage from A.C. to D.C. It passes current in one direction and blocks it in the other. Also called a rectifier.

Magnetron

With filament voltage and high D.C. voltage from the output of the H.V. capacitor/diode junction, the magnetron will put out an electromagnetic radio frequency of 2450 MHz to heat the food load in the oven.

Thermal Cutout Protectors

At a predetermined temperature, the thermal cut-outs will open.

- Magnetron thermal cut-outs are mounted directly on the body of the magnetron.
- Cavity thermal cut-out is mounted directly on the left side of cavity exterior, inside the exhaust duct.

Touch Panels

Allows consumer operation and programming of oven.

Triac

Triac is controlled by control board. Triac controls one side of the power line going to the high voltage power transformer.

- Triac is mounted on blower bracket.

Antenna Motor(s)

Antenna motor(s) rotate(s) antenna assemblies.

Installation

Unpacking Oven

- Remove packing and printed material from oven cavity.
- Inspect oven for damage such as dents in door or inside oven cavity.
- Report any dents or breakage to source of purchase immediately. Do not attempt to use oven if damaged.
- If oven has been stored in extremely cold area, wait a few hours before connecting power.

Oven Placement

- Do not install oven next to or above source of heat, such as pizza oven or deep fat fryer. This could cause microwave oven to operate improperly and could shorten life of electrical parts.
- Do not block or obstruct oven filter. Allow access for cleaning.
- Install oven on level countertop surface.

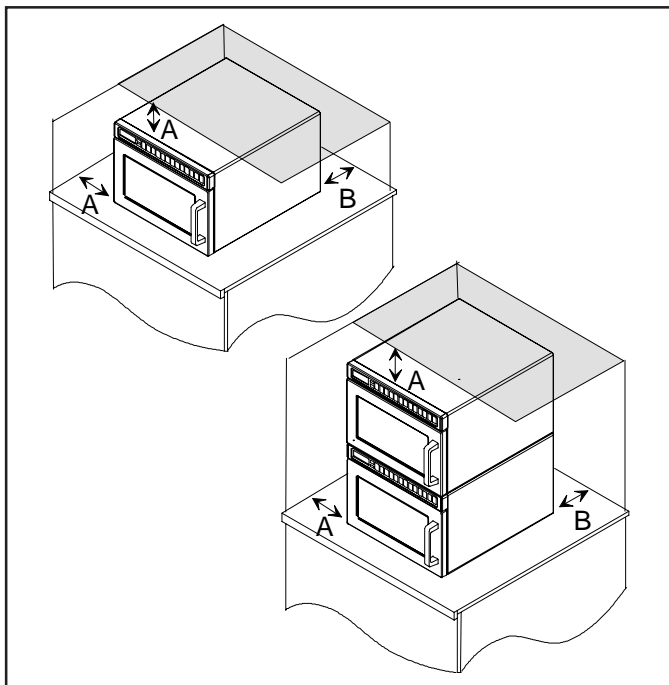

A—Allow at least 7" (17.8 cm) of clearance around top and sides of oven. Proper air flow around oven cools electrical components. With restricted air flow, oven may not operate properly and life of electrical parts is reduced.

B—Allow at least 2 9/16" (6.5 cm) between air discharge on back of oven and back wall.

Radio Interference

Microwave operation may cause interference to radio, television, or similar equipment. Reduce or eliminate interference by doing the following:

- Clean door and sealing surfaces of oven according to instructions in "Care and Cleaning" section.
- Place radio, television, etc. as far as possible from oven.
- Use properly installed antenna on radio, television, etc. to obtain stronger signal reception.

Grounding Instructions

NOTE: Do not under any circumstances cut or remove grounding prong from the plug or bend power prongs to fit receptacle other than one shown for your equipment. Such abuse of the plug can result in electrical shock or overheating.

WARNING

Improper use of grounding plug can result in a risk of electrical shock or death.

This equipment **MUST** be grounded. In the event of an electrical short circuit, grounding reduces risk of electric shock by providing an escape wire for electric current. This oven is equipped with a cord having grounding wire with a grounding plug. Plug must be plugged into an outlet that is properly installed and grounded. **DO NOT** use a two-prong adapter.

Consult a qualified electrician or servicer if grounding instructions are not completely understood, or if doubt exists as to whether the equipment is properly grounded.

Do not use an extension cord. If product power cord is too short, have a qualified electrician install an appropriate receptacle. This equipment should be plugged into a separate 60 Hz circuit with the appropriate electrical rating as shown in the drawings. When an oven is on a circuit with other equipment, an increase in cooking times may be required and fuses can be blown.

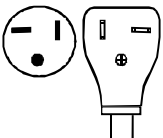
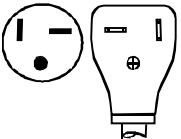
Model	NEMA Designation	Receptacle and Plug
HDC10 HDC12	NEMA 5-20R/5-20P 120V-20AMP	
HDC18 HDC18SD HDC21	NEMA 6-20R/6-20P 250V-20AMP	

Care and Cleaning

Changing Oven Light Bulb

CAUTION

To avoid electrical shock hazard unplug power cord or open circuit breaker to microwave oven before replacing light bulb. After replacing light bulb, reconnect power.

CAUTION

To avoid burns and cuts, wear gloves to protect hands should bulb break. If hot, allow bulb to cool.

Tools and Bulb

- Protective gloves
- Standard screwdriver or ¼ inch socket
- Light bulb rated 120 volt, 25 watt

1. Unplug oven.
2. Remove screw from side of oven and remove access cover.

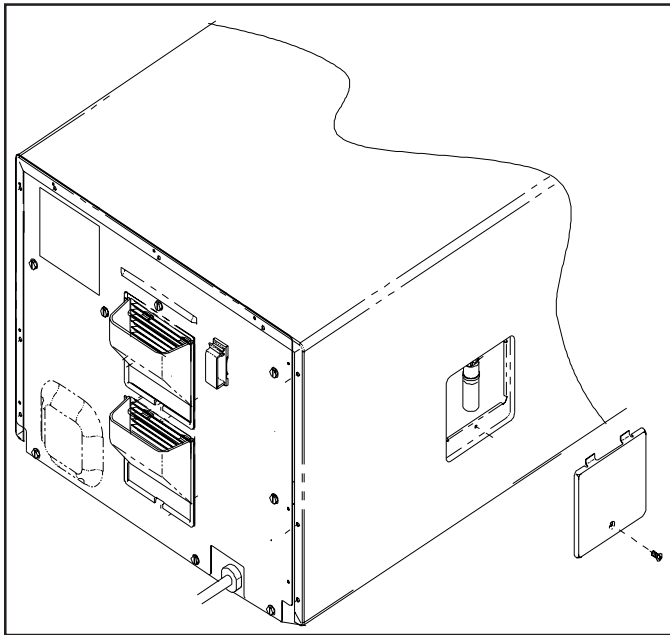

3. Remove bulb by turning counterclockwise, being careful not to burn fingers or break bulb.
 - Replace with bulb rated 120 volt, 25 watt.
5. Reverse procedure to reassemble.

Cleaning Interior, Exterior, and Door

WARNING

To avoid electrical shock which can cause severe personal injury or death, unplug power cord or open circuit breaker to oven before cleaning.

Clean microwave oven with mild detergent in warm water using soft sponge or cloth. Wring sponge or cloth to remove excess water before wiping equipment. If desired, boil a cup of water in microwave oven to loosen soil before cleaning.

- Do not use abrasive cleansers or cleaners containing ammonia. These could damage finish.
- Never pour water into microwave oven bottom.
- Do not use water pressure type cleaning systems.

Cleaning Splatter Shield

Splatter shield keeps top of microwave oven cavity and antenna from becoming soiled. Clean soil from shield with damp cloth or clean with mild detergent and water.

Remove splatter shield for easy cleaning.

1. Unplug oven before removing splatter shield to stop antenna from rotating.
2. Place fingers behind shield, pull forward, and down.
 - When removing and replacing splatter shield, be careful not to bend antenna.
3. Wash shield in hot, soapy water. Rinse and dry thoroughly.
 - Do not wash splatter shield in dishwasher.
 - Do not use abrasive cleaners.
4. Reinstall splatter shield by placing front portion of the shield in first. Lift until shield slides into holes located in back of oven.

Correct Installation

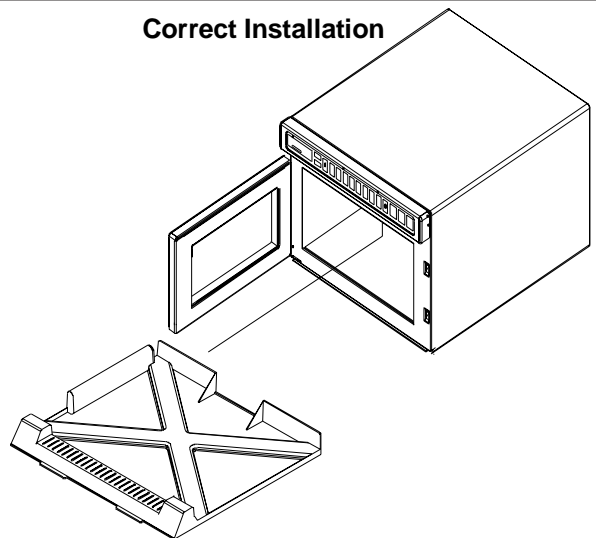

Care and Cleaning

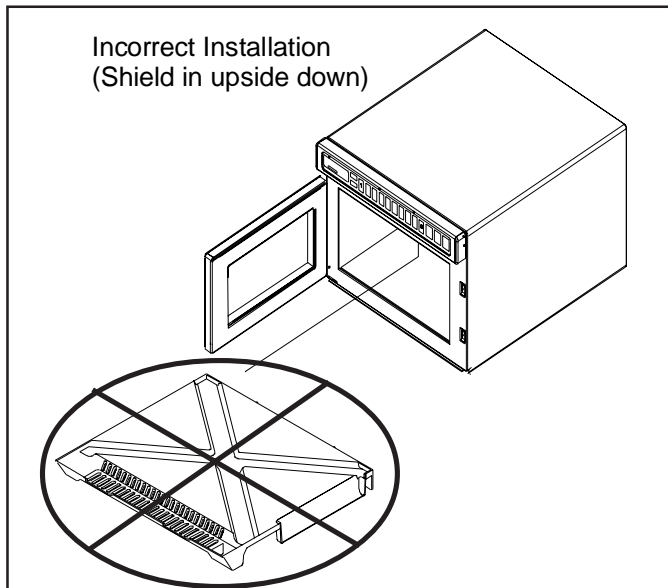

NOTE: If splatter shield is installed upside down, shield will interfere with antenna movement.

Cleaning Air Intake Filter



CAUTION

To avoid overheating and oven damage, clean air filter regularly.



CAUTION

To avoid oven door damage, do not lift oven by oven door.

Filter is located below oven door. Clean air intake filter weekly for proper air flow. Wash filter in hot water and mild detergent. Do not use oven without filter in place.

To remove filter

- Locate plastic tab in the center of filter and pull downward (rolling the filter), to release filter from metal holding tabs.

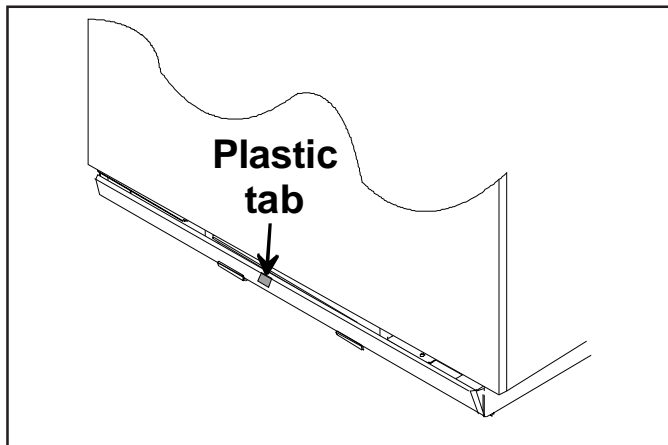

To replace filter

- Place bottom portion of filter into position first and push in on the top portion of the filter, until filter is securely in place.

NOTE: When placing filter back into position, verify plastic tab is on the outside of the unit.

Cleaning Discharge Air Vents

Check for a buildup of cooking vapors along discharge louvers in back of oven. Clean air vent with damp cloth to ensure proper airflow. Dry thoroughly.

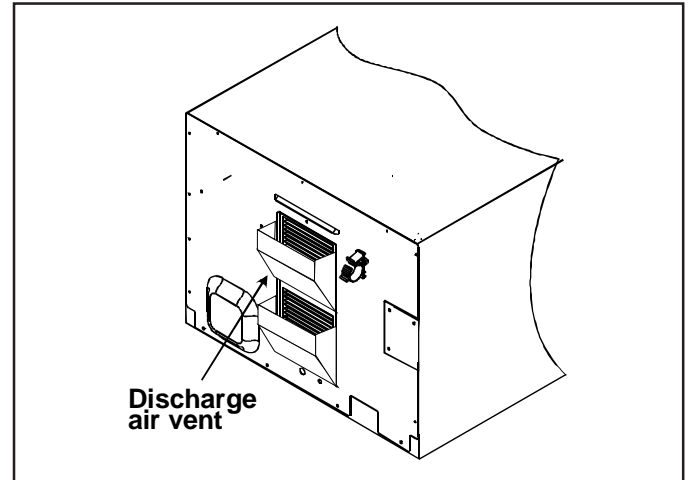

Control Panel Features



TIME ENTRY pad is used to enter cooking time for either manual entry or programming. Cooking time ranges from 1 second (00:01) to a total of 60 minutes (60:00) over four stages. If more than 60 minutes of total microwave cooking time is required, open door and inspect food before beginning new cooking cycle.

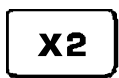

X2 pad increases the cooking time when cooking more than one item at a time is necessary. The amount of added time when the X2 pad is pressed is a percent of the original preprogrammed cooking time. The percent can be set from 10% to 100% with the default at 80%. The percent of the time added can be changed for individual cooking sequences.

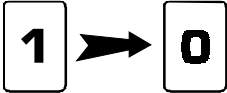

Numbered pads begin cooking programs or enter times and power levels for "Manual Time Entry" cooking.



POWER LEVEL pad is used to set microwave power level. When cooking, the power level can be decreased for foods that require slower more even cooking. Microwave power levels range from 0% to 100% in 10% increments. If cooking time is set and START pad pressed, oven cooks at 100% power. When programming, to reset power level to 100%, press POWER LEVEL pad.



START pad begins Manual Time Entry cooking or restarts an interrupted cooking cycle. When programming, use to save time and power level, and to advance to next user option.



STOP/RESET pad exits programming mode and stop cooking during cooking cycle.

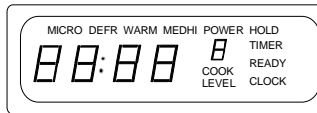

Display Some items in display can be seen but will not glow.

Stages

This oven can be programmed to run 4 cooking sequences consecutively. Each sequence is called a stage. For example, the first cycle could be programmed to defrost at 60% power, the second to defrost at 30% power, the third to heat at 100% power, and the fourth to hold warm at 10% power. Total time for all cooking stages counts down.

User Options

User Options allow the user to program the oven to perform in a way convenient to the user. The beeps, maximum cooking time, and number of preprogrammed cooking sequences can be changed.

Displays

Cooking Methods

Memory Pads

This oven can store either 10 or 100 cooking programs in memory.

Single Pad Cooking

From the factory, it is programmed to store 10 cooking programs. Each pad begins a cooking program.

Double Pad Cooking

The oven control can be changed to store up to 100 cooking programs. To set the control to 100 cooking programs, see the "User's Options" section of this manual. To heat when the oven is set for 100 programs, press 2 memory pads. For example, to start the first program, press pad 0, then pad 1. To use the second program, press pad 0, then pad 2. After the pads are pressed, the oven starts automatically and time counts down.

Manual Time Entry

Manual Time Entry feature allows the operator to heat without changing the preprogrammed pads. Time must be entered and power can be set before cooking. START pad must be pressed to begin cooking.

Cooking Displays

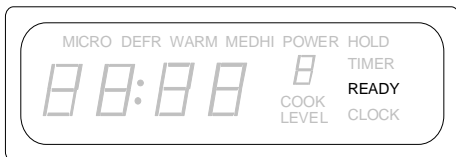

READY shows when oven control will accept entries.

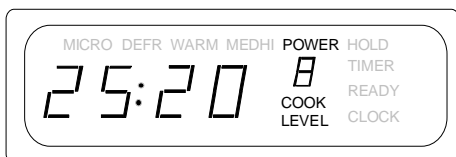

25:20 shows cooking time. When more than one cooking stage is programmed, total time for all stages displays. POWER Shows when microwave energy is generated. COOK LEVEL shows when oven is operating. 8 indicates the microwave power level used. If number does not show, oven is cooking at 100% power.

Programming Displays

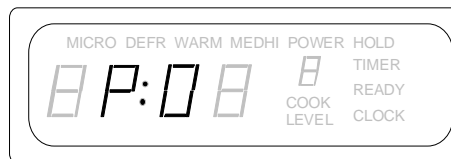

This display indicates oven is in programming mode and ready to program a numbered pad(s).

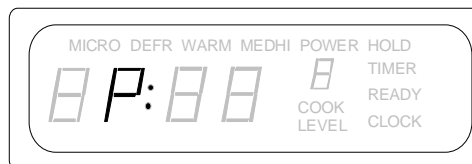

This display indicates oven is set to double pad entry and 2 pads must be pressed to enter a program. See "Programming" section of manual for programming procedure or "User Options" to change from single or double pad entry.

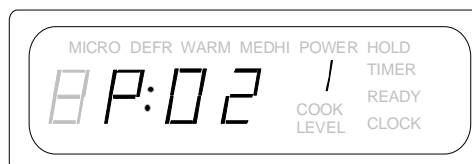

This display shows briefly when programming more than one stage. It indicates programming mode for pad 02. The smaller "1" indicates stage 1 is being programmed.

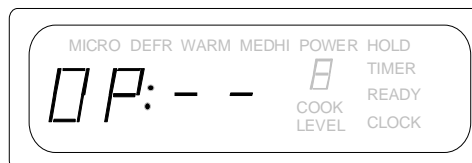

This display indicates programming user options mode. See "User Options" section of manual for programming procedure.

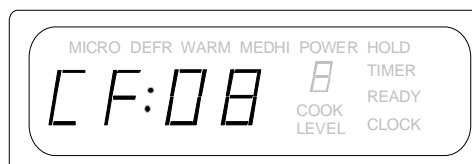

This display indicates cooking factor of 80% when X2 pad is pressed.

Operation

Interrupting Operation

Open oven door or press *STOP/RESET* pad to interrupt operation. Display continues to show countdown time. Close door and press *START* pad to resume oven operation.

Canceling Mistakes

If oven is not cooking, press *STOP/RESET* pad to clear display. If oven is cooking, press *STOP/RESET* pad once to stop oven, then again to clear display. If oven door is open and time shows in display, close oven door and press *STOP/RESET* pad to clear display.

Operating Preprogrammed Pads

From the factory, this oven can store up to 10 preprogrammed cooking sequences in memory. To heat using a preprogrammed sequence, press a numbered pad. Oven starts to heat automatically. Example: Heat using the third cooking sequence.

1. Open oven door, place food in oven, and close oven door.
 - Display shows "READY".
 - If pad is not pressed in 60 seconds, open and close oven door again.
2. Press 3 pad.
 - Oven operates and time counts down.
 - Display shows cooking time, "POWER", "COOK LEVEL". Display shows "POWER" only when microwave energy is present.
 - If power level other than 100 percent power was programmed, display shows "COOK LEVEL" and power level.
 - If additional cooking time is required, press preprogrammed pads before or after cooking cycle ends.
3. Oven stops cooking and oven signal sounds when cooking timing elapses.

Preprogrammed Times and Cook Level

All preprogrammed pads arrive set at full power.

Pads	Times	Pads	Times
1	10 sec.	6	1:30 min.
2	20 sec.	7	2 min.
3	30 sec.	8	3 min.
4	45 sec.	9	4 min.
5	1 min.	0	5 min.

Double Pad Programs

The oven control can be changed to store up to 100 cooking programs. See the "User's Options" section of this manual to change oven control.

To start a double pad cooking program, press 2 memory pads. For example, press pad 0 and pad 3 to start a cooking program.

Using X2 Pad

X2 pad increases the cooking time when cooking more than one item at a time is necessary. The amount of added time when the X2 pad is pressed is a percent of the original preprogrammed cooking time. The percent can be set from 10% to 100% with the default at 80%. The percent of the time added can be changed for individual cooking programs.

Press X2 pad before pressing memory pad. For example, press X2 pad and then memory pad 3. Pad 3 normally cooks for 30 seconds. When the X2 pad is pressed before memory pad 3, 54 seconds displays because it added 24 seconds, (80% of 30 sec. =24 sec.).

Manual Time Entry

Manual Time Entry feature allows the operator to enter time and power levels, and heat without changing the preprogrammed pads. Example: Heat for 30 seconds at 80% power.

1. Open oven door, place food in oven, and close door.
 - Display shows "READY". Fan and light operate.
 - If pad is not pressed in 60 seconds, open and close oven door again.
2. Press TIME ENTRY pad.
 - Display shows "0000" and "READY".
3. Press 3 and 0 pad to enter cooking time.
4. Press POWER LEVEL pad to change power level.
 - Display shows "COOK LEVEL" and current power level if other than 100 percent power.
5. Press 8 pad to enter desired power level.
6. Press START pad.
 - Oven operates and time counts down.
 - Display shows cooking time, "POWER", "COOK LEVEL".
 - Display shows "POWER" only when microwave energy is present.
 - If power level other than 100 percent power was programmed, display shows "COOK LEVEL" and power level. Display counts down cooking time.
7. Oven stops cooking and oven signal sounds when cooking timing elapses.

Programming Instructions

Memory Pads

From the factory, this oven can store up to 10 cooking programs. Follow instructions below to program cooking times and power levels for customized cooking.

Example: Program third cooking sequence to heat for 30 seconds at 80% power.

1. Open oven door.
 - Display shows "READY".
 - If door is closed or RESET pad is pressed before finishing programming sequence, oven exits programming mode.
2. Press and hold pad 1 for approximately 5 seconds.
 - After 5 seconds, signal sounds. Display shows "P:0".
3. Press 3 pad to select memory pad.
 - Display shows cooking time, "COOK LEVEL" and power level if other than 100 percent power.
4. Press 3 and 0 pad to enter desired cooking time.
5. Press POWER LEVEL pad to change power level.
 - Display shows "COOK LEVEL" and current power level if other than 100 percent power.
6. Press 8 pad to enter desired power level.
7. Press START pad to save new cooking time and power level in oven memory.
 - Display shows "P:0".
 - Repeat step 3–8 to program additional pads.
8. Press STOP/RESET pad or close oven door to exit programming mode.

Double Pad Programs

The oven control can be changed to store up to 100 cooking programs. See the "User's Options" section of this manual to change oven control.

To create a double pad program, follow the instructions above except for a change to step #3. When entering the cooking program number, press 2 memory pads. For example, press pads 0 and pad 3 to create a new cooking program.

Multiple Cooking Stages

Follow instructions below to program oven to perform four consecutive cooking cycles without interruption.

Example: Program third cooking sequence to heat for 30 seconds at 80% power, 40 seconds at 50% power, and 10 seconds at 100% power.

1. Open oven door.
 - Display shows "READY".
 - If door is closed or RESET pad is pressed before finishing programming sequence, oven exits programming mode.
2. Press pad 1 for approximately 5 seconds.
 - After 5 seconds, signal sounds. Display shows "P:0".
4. Press 3 pad to select memory pad.
 - Display shows cooking time, "COOK LEVEL" and power level if other than 100 percent power.

5. Press 3 and 0 to enter desired cooking time.
6. Press POWER LEVEL pad to change power level.
 - Display shows "COOK LEVEL" and current power level if other than 100 percent power.
7. Press 8 pad to enter desired power level.
8. Press TIME ENTRY pad.
 - Display briefly shows "P:03⁽¹⁻⁴⁾" indicating programming, pad 3, stage 2. Then cook time and power level for stage show in display.
 - Repeat steps 5–8 to create additional stages.
9. Press START pad to save new cooking time and power level in oven memory.
10. Press STOP/RESET pad or close oven door to exit programming mode.

X2 Quantity Feature

This feature allows the user to change the amount of time added when the X2 pad and then the programmed pad is pressed. Based on the original time, the X2 pad can add from 10%-100% of additional cooking time. The default is 80%. Example: change cooking factor to 50% for third cooking sequence.

1. Open oven door.
 - If door is closed or RESET pad is pressed before finishing programming sequence, oven exits programming mode.
2. Press and hold pad 1 for approximately 5 seconds.
 - After 5 seconds, signal sounds. Display shows "P:-".
3. Press 3 pad to select the cooking program.
4. Press 5 pad to change cooking factor.
 - Display shows "CF:05".
5. Press START pad to save changes.
6. Press STOP/RESET pad or close oven door to exit programming mode.

Double Pad Programs

The oven control can be changed to store up to 100 cooking programs. See the "User's Options" section of this manual to change oven control.

To change the quantity for a double pad program, follow the instructions above except for a change to step #3. When entering the cooking program number, press 2 memory pads. For example, press pads 0 and pad 3 to create a new cooking program. After the program is saved, press pad 0 and pad 3 to start a cooking program.

Programming Instructions

User Options

Follow the instructions below to customized the microwave oven's operation. End-of-cycle signal, maximum cooking time and other options can be changed to meeting your cooking needs. Example: Change setting to single digit pad operation.

1. Open oven door.
 - If door is closed or *RESET* pad is pressed before finishing programming sequence, oven exits programming mode.
2. Press and hold pad 2 for approximately 5 seconds.
 - After 5 seconds, signal sounds. Display shows "OP:".
3. Press 9 pad.
 - See table for options.
 - Displays shows "OP:91".
 - "OP" represents optional program mode, first number represents option number and second number represents functions currently selected for option.
4. Press 9 pad repeatedly to change setting.
5. Press START pad to save changes.
 - Repeat steps 3-5 to change additional options.
 - Changes appear after door is closed or STOP/RESET is pressed.
6. Press STOP/RESET pad or close oven door to exit programming mode.

Numbered Pads	Display	Options (Factory Settings in Bold)
1 End of Cycle Beep	OP:10 OP:11 OP:12	3 second continuous beep. Continuous beep until door is opened. 5 beeps bursts until door is opened.
2 Speaker Volume	OP:20 OP:21 OP:22 OP:23	Eliminates beep. Sets volume to low. Sets volume to medium. Sets volume to high.
3 Key Beep	OP:30 OP:31	Prevents beep when pad is pressed. Allows beep when pad is pressed.
4 Keyboard Enable Window	OP:40 OP:41 OP:42 OP:43	15 seconds after oven door is opened, keyboard disabled. 30 seconds after oven door is opened, keyboard disabled. 1 minute after oven door is opened, keyboard disabled. 2 minutes after oven door is opened, keyboard disabled.
5 Add Time during Heating	OP:50 OP:51	Prevents adding heating time while oven is heating. Allows heating time to be changed while oven is heating when a memory pad is pressed.
6 Reset Door Open	OP:60 OP:61	Allows oven to resume heating time countdown after door is opened during cycle. Cancels heating time countdown after door is opened during cycle.
7 Maximum Heating Time	OP:70 OP:71	Allows 60 minutes of heating time. Allows 10 minutes of heating time.
8 Manual Operation	OP:80 OP:81	Allows use of preprogrammed pads only. Allows use of manual time entry and preprogrammed pads.
9 Double Digit Operation	OP:90 OP:91	Allows 10 (0-9) preprogrammed pads. Allows 100 (00-99) preprogrammed pads.

Component Testing Procedures



WARNING

To avoid risk of electrical shock, personal injury, or death, disconnect power to oven and discharge capacitor before servicing, unless testing requires it.

Illustration	Component	Testing	Results
	Thermal Cutout	Disconnect all wires from TCO. Measure resistance across terminals. Cavity Thermal Fuse Magnetron TCO	Open at 219°F (104°C) Open at 280°F (138°C) and closed at 180°F (82°C)
	Diode Assembly	Discharge Capacitors Remove diode lead from capacitor and connect ohmmeter. Reverse leads for second test.	Infinite resistance should be measured in one direction and 50KΩ or more in the opposite direction. NOTE: Analog meter must contain a battery of 6 volts minimum.
	Triac	Disconnect wires to triac. Measure resistance from: MT1 to MT2 MT1 to Gate MT2 to Gate All terminals to ground	Caution - Do not operate oven with wire to terminal MT2 removed. Infinite Approximately 40 Ω or more Infinite Infinite
	Capacitor	Discharge Capacitors Remove wires from capacitor terminals and connect ohmmeter, set on highest resistance scale to terminals. Also check between each terminal and capacitor case.	Between Terminals: Meter should momentarily deflect towards zero then return to over 5 MΩ. IF no deflection occurs, or if continuous deflection occurs, replace capacitor. Terminal to Case: Infinite resistance
	Snubber Assembly	Disconnect wires to snubber. Measure resistance across terminals.	Infinite
	Magnetron	Discharge Capacitors Remove wires from magnetron and connect ohmmeter to terminals. Also check between each terminal and ground.	Between Terminals: Less than 1 Ω Each terminal to ground measures Infinite resistance. Note: This test is not conclusive. If oven does not heat and all other components test good replace the magnetron and retest.
	Blower Motor	Remove all wires from motor. Measure resistance across coil.	Approximately 30 Ω
	Antenna motor	Remove all wires from motor. Measure resistance across terminals.	Circuitry 120 VAC—Approximately 3.4 KΩ 230 VAC—Approximately 12 KΩ
	Auto Transformer	Discharge Capacitors Remove all wires from terminals. Measure resistance from: 230 to 0 208 to 0 120 to 0	42.4 Ω 38.6 Ω 21.5 Ω
Wire Harness		Test continuity of wires.	Indicates continuity

Component Testing Procedures

⚠ WARNING

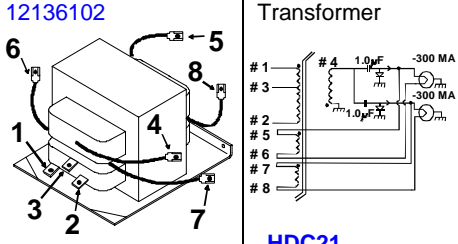
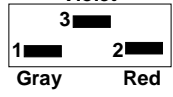
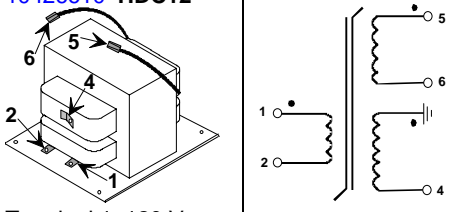
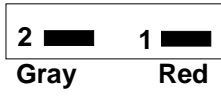
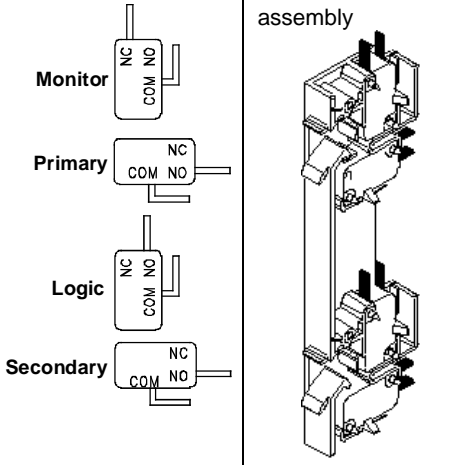
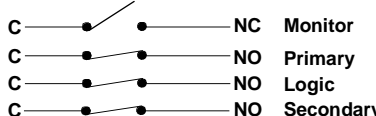
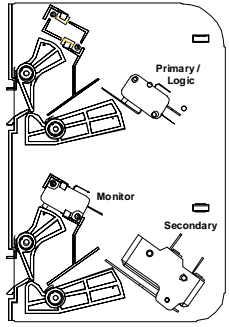
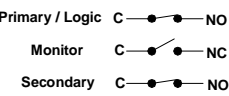

To avoid risk of electrical shock, personal injury, or death, disconnect power to oven and discharge capacitor before servicing, unless testing requires it.

Illustration	Component	Testing	Results
<p>12136102</p>  <p>Terminal 1– 230 V Terminal 2– Common Terminal 3–208 V</p>	<p>Transformer</p> <p>HDC21, HDC18SD, HDC18 CRC18T2OG CRC21T2RL</p>	<p>Discharge Capacitors Remove all wires from terminals. Measure resistance from:</p> <ul style="list-style-type: none"> Terminal 1 to 2 Terminal 1 to 3 Terminal 5 to 6 Terminal 7 to 8 Terminal 4 to Ground screw on transformer Terminal 4 to any other terminal <p style="text-align: center;">Violet</p> 	<ul style="list-style-type: none"> 1.0 Ω Less than 1 Ω Less than 1 Ω Less than 1 Ω 30 Ω Infinite resistance should be indicated, if not replace transformer.
<p>10426609–HDC10 10426610–HDC12</p>  <p>Terminal 1–120 V Terminal 2–Common</p>	<p>Transformer</p>	<p>Discharge Capacitor Remove all wires from terminals, and measure resistance from:</p> <ul style="list-style-type: none"> Terminal 1 to 2 Terminal 5 to 6 Terminal 4 to Ground screw on transformer Terminal 4 to any other terminal 	<ul style="list-style-type: none"> Less than 1 Ω Less than 1 Ω 78 Ω Infinite resistance should be indicated, if not replace transformer.
<p>R0150154</p> 	<p>Interlock switch assembly</p>	<p>Disconnect wires to switch.</p> <p>With door open measure resistance from:</p> <ul style="list-style-type: none"> Terminal C to NC Monitor Terminal C to NO Primary Terminal C to NO Logic Terminal C to NO Secondary <p>With door closed measure resistance from:</p> <ul style="list-style-type: none"> Terminal C to NC Monitor Terminal C to NO Primary Terminal C to NO Logic Terminal C to NO Secondary <p style="text-align: center;">Door Closed</p> 	<ul style="list-style-type: none"> Indicates continuity Infinite Infinite Infinite Infinite Indicates continuity Indicates continuity Indicates continuity
<p>12538901Q</p> 	<p>Interlock switch assembly</p> <p style="text-align: center;">Door Closed</p> 	<p>Disconnect wires to switch.</p> <p>With door open measure resistance from:</p> <ul style="list-style-type: none"> Terminal C to NC Monitor Terminal C to NO Primary Terminal C to NO Logic Terminal C to NO Secondary <p>With door closed measure resistance from:</p> <ul style="list-style-type: none"> Terminal C to NC Monitor Terminal C to NO Primary Terminal C to NO Logic Terminal C to NO Secondary 	<ul style="list-style-type: none"> Indicates continuity Infinite Infinite Infinite Infinite Indicates continuity Indicates continuity Indicates continuity

Component Testing Procedures

⚠ WARNING

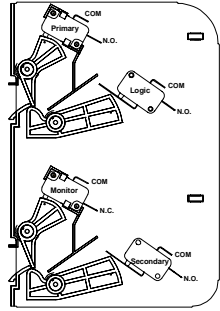
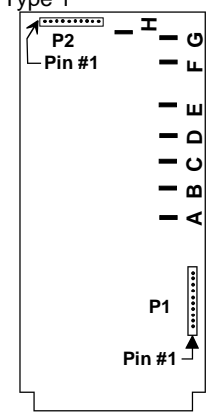
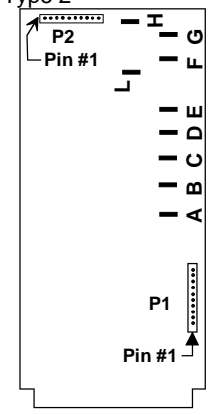
To avoid risk of electrical shock, personal injury, or death, disconnect power to oven and discharge capacitor before servicing, unless testing requires it.

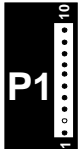
Illustration	Component	Testing	Results
<p>R0000277</p> 	<p>Interlock switch assembly</p> <p>Door Closed</p> <p>Primary C — ● — NO Logic C — ● — NO Monitor C — ● — NC Secondary C — ● — NO</p>	<p>Disconnect wires to switch.</p> <p>With door open measure resistance from: Terminal C to NO Primary Terminal C to NO Logic Terminal C to NC Monitor Terminal C to NO Secondary</p> <p>With door closed measure resistance from: Terminal C to NO Primary Terminal C to NO Logic Terminal C to NC Monitor Terminal C to NO Secondary</p>	<p>Infinite Infinite Indicates continuity Infinite</p> <p>Indicates continuity Indicates continuity Infinite Indicates continuity</p>
<p>Type 1</p>  <p>Type 2</p> 	<p>Controller board</p> <p>Type 1</p> <p>CRC18T2OG P1323006M CRC21T2RL P1323007M HDC18 P1323003M HDC18SD P1323004M HDC21 P1323005M</p> <p>Type 2</p> <p>CRC18T2OG P1323015M CRC21T2RL P1323017M HDC18 P1323013M HDC18SD P1323014M HDC21 P1323016M</p>	<p>All Models</p> <p>Line voltage to control board P2 connector Pin 1 — Pin 3</p> <p>Output drive voltage to triac Triac terminals Gate — T1</p> <p>208 VAC line voltage</p> <p>Fan relay (controls blower motor, antenna motor(s), and oven light) Control board..... Terminals C — D</p> <p>Line voltage sensing relay (automatically switches for 208 or 230 VAC operation) Control board..... Terminals F — G</p> <p>230 VAC line voltage</p> <p>Fan relay (controls blower motor, antenna motor(s), and oven light) Control board..... Terminals C — E</p> <p>Line voltage sensing relay (automatically switches for 208 or 230 VAC operation) Control board..... Terminals F — H</p>  	<p>Line voltage (All Condition)</p> <p>0 VAC (Idle and Standby) 0.9 VAC (Cook)</p> <p>Line voltage (Idle) 0 VAC (Standby and Cook)</p> <p>Line voltage (Idle) 0 volts (Standby and Cook)</p> <p>Line voltage (Idle) 0 VAC (Standby and Cook)</p> <p>Line voltage (Idle) 0 volts (Standby and Cook)</p> <p>P1 connector used for touch panel ribbon</p>

Component Testing Procedures



WARNING

To avoid risk of electrical shock, personal injury, or death, disconnect power to oven and discharge capacitor before servicing, unless testing requires it.

Illustration	Component	Testing	Results		
<p>Type 3 HDC10, HDC12</p>	<p>Controller board</p> <p>P1 connector used for touch panel ribbon</p>	<p>All Models Line voltage to control board P2 connector Pin 1 — Pin 3..... Output drive voltage to triac Triac terminals Gate — T1</p> <p>120 VAC Fan relay (controls blower motor, antenna motor(s), and oven light) Control board Terminals C — J</p> <p>Cook relay Control board Terminals F — K</p>	<p>Line voltage (All Condition)</p> <p>0 VAC (Idle and Standby) 0.9 VAC (Cook)</p> <p>Line voltage (Idle) 0 VAC (Standby and Cook)</p> <p>Line voltage (Idle) 0 volts (Standby and Cook)</p>		
	<p>Touch Panel Assembly</p>	<p>Continuity is indicated as 100 Ω and below.</p> <p>Pin 1: is considered Ground</p>	<p>Pad</p> <p>1</p> <p>2</p> <p>3</p> <p>4</p> <p>5</p> <p>6</p> <p>7</p> <p>8</p> <p>9</p> <p>0</p> <p>Start</p> <p>Stop/Reset</p> <p>Power Level</p> <p>X 2</p> <p>Time Entry</p>	<p>Pin</p> <p>8 & 10</p> <p>7 & 10</p> <p>6 & 10</p> <p>5 & 10</p> <p>4 & 10</p> <p>3 & 10</p> <p>8 & 9</p> <p>7 & 9</p> <p>6 & 9</p> <p>5 & 9</p> <p>4 & 9</p> <p>4 & 8</p> <p>5 & 8</p> <p>6 & 8</p> <p>7 & 8</p>	<p>Measurement</p> <p>Continuity</p> <p>Continuity</p> <p>Continuity</p> <p>Continuity</p> <p>Continuity</p> <p>Continuity</p> <p>Continuity</p> <p>Continuity</p> <p>Continuity</p> <p>Continuity</p> <p>Continuity</p> <p>Continuity</p> <p>Continuity</p> <p>Continuity</p> <p>Continuity</p> <p>Continuity</p> <p>Continuity</p> <p>Continuity</p> <p>Continuity</p>

Conditions

- Initial Power Up Condition:** Apply power to oven with door closed—see, “Troubleshooting” section.
- Idle Condition:** Oven plugged in, display blank (no other components operating).
- Standby Condition:** Open oven door, light and motors operate—see, “Troubleshooting” section.
- Cook Condition:** Food load in oven, cook cycle initiated—see, “Troubleshooting” section.

Test Modes

Power Test (Traditional Test Method)

Test equipment required is Amana power test kit R0157397 (Fahrenheit), or Menumaster power test kit M95D5 (Celsius).

1. Fill the plastic container to the 1000 ml. line with cool tap water.
2. Using the thermometer; stir the water, measure, and record the water temperature.
Initial water temperature should be approximately 60°F (16°C).
3. Place container on the center of the oven shelf and heat the water for
33 seconds for ovens with more than 1550 watts or 63 seconds for ovens with less than 1550 watts.

NOTE: Use a watch second hand, not the oven timer.

4. Stir the water, measure and record the temperature of the water after heating time is complete.
5. Subtract the starting water temperature (Step 2), from the ending water temperature (Step 4) to obtain the temperature rise (DT).
6. See the Traditional Power Test Temperature Chart below.

NOTES:

- The IEC-705 test method requires precision measurements and equipment. It is not practical to perform the IEC test in the field. To convert the traditional power test results to the approximate IEC-705 rating, take the traditional power test results and add 100 watts per magnetron for the unit being tested.

Example: 1627 — watts output using the traditional power test for model [HDC18](#)

+ 200 — watts (2 magnetrons X 100 watts)

1827 — Approximate IEC-705 results

- Always perform power test three times for accuracy, changing the water after each test is performed.
- Variation or errors in the test procedure will cause a variance in the temperature rise. Additional power tests should be made if temperature rise appears marginal.
- Low line voltage will cause lower temperature rise.

Temperature Chart

ONE MINUTE, THREE SECONDS run time chart for units less than 1550 watts cooking power.

ΔT (°F)	Cooking Power Output	ΔT (°F)	Cooking Power Output
16	620	26	1007
17	659	27	1046
18	697	28	1085
19	736	29	1124
20	775	30	1162
21	814	31	1201
22	852	32	1240
23	891	33	1279
24	930	34	1317
25	969		

ΔT (°C)	Cooking Power Output	ΔT (°C)	Cooking Power Output
7	490	15	1050
8	560	16	1120
9	630	17	1190
10	700	18	1260
11	770	19	1330
12	840	20	1400
13	910	21	1470
14	980	22	1540

THIRTY THREE SECONDS run time chart for units more than 1550 watts cooking power.

ΔT (°F)	Cooking Power Output	ΔT (°F)	Cooking Power Output
20	1550	25	1937
21	1627	26	2015
22	1705	27	2092
23	1782	28	2170
24	1860	29	2247

ΔT (°C)	Cooking Power Output	ΔT (°C)	Cooking Power Output
11	1540	14	1960
11.5	1610	14.5	2030
12	1680	15	2100
12.5	1750	15.5	2170
13	1820	16	2240
13.5	1890		

Microwave Energy Leakage Testing



WARNING

Check for radiation leakage after servicing. Should the leakage be more than $4\text{mW}/\text{cm}^2$ inform Amana immediately. After repairing or replacing any radiation safety device, keep a written record for future reference, as required by D.H.H.S. and HEW regulations. This requirement must be strictly observed. In addition, the leakage reading must be recorded on the service repair ticket while at the customer's location.

Equipment

- Electromagnetic radiation monitor
- 600 cc glass beaker

Procedure For Measuring Radiation Leakage

Note before measuring -

- Do not exceed meter full scale deflection. Leak monitor should initially be set to the highest scale.
 - To prevent false readings the test probe should be held by the grip portion of the handle only.
 - The scan speed is equal to one inch per antenna revolution or one inch per second if antenna speed is unknown.
 - Areas to be checked are all door seal areas and any venting parts.
 - Leakage with the outer panel removed, $4\text{mW}/\text{cm}^2$ or less.
 - Leakage for fully assembled oven with door normally closed, $4\text{mW}/\text{cm}^2$ or less.
 - Leakage for a fully assembly oven (before the latch switch (primary) is interrupted) while pulling the door, $4\text{mW}/\text{cm}^2$ or less.
1. Pour 275 ± 15 cc (9 oz \pm 1/2 oz) of $20 \pm 5^\circ\text{C}$. ($68 \pm 9^\circ\text{F}$.) water in a glass beaker which is graduated to 600 cc and place the beaker in the center of shelf.
 2. Set the radiation monitor to 2450 MHz and use it following the manufacturer's recommended test procedure to assure correct results.
 3. While measuring the leakage, always use the two inch (5 cm) spacer supplied with the probe.
 4. Press the start pad or turn on the timer and with the magnetron oscillating, measure the leakage by holding the probe perpendicular to the surface being measured.

Measurement With the Outer Case Removed



DANGER

To avoid risk of personal injury or death avoid contacting any high voltage components.

Whenever you replace the magnetron, measure for radiation leakage before the outer case is installed and after all necessary components are replaced or adjusted. Special care should be taken in measuring around the magnetron.

Measurement With a Fully Assembled Oven

After all components, including the outer panel are fully assembled, measure for radiation leakage around the door periphery, the door viewing window, the exhaust opening, and air inlet openings.

Record Keeping and Notification After Measurement

1. After any adjustment or repair to a microwave oven, a leakage reading must be taken. Record this leakage reading on the repair ticket even if it is zero.
2. A copy of the repair ticket and the microwave leakage reading should be kept by the repair facility.

Troubleshooting

Initial Power Up

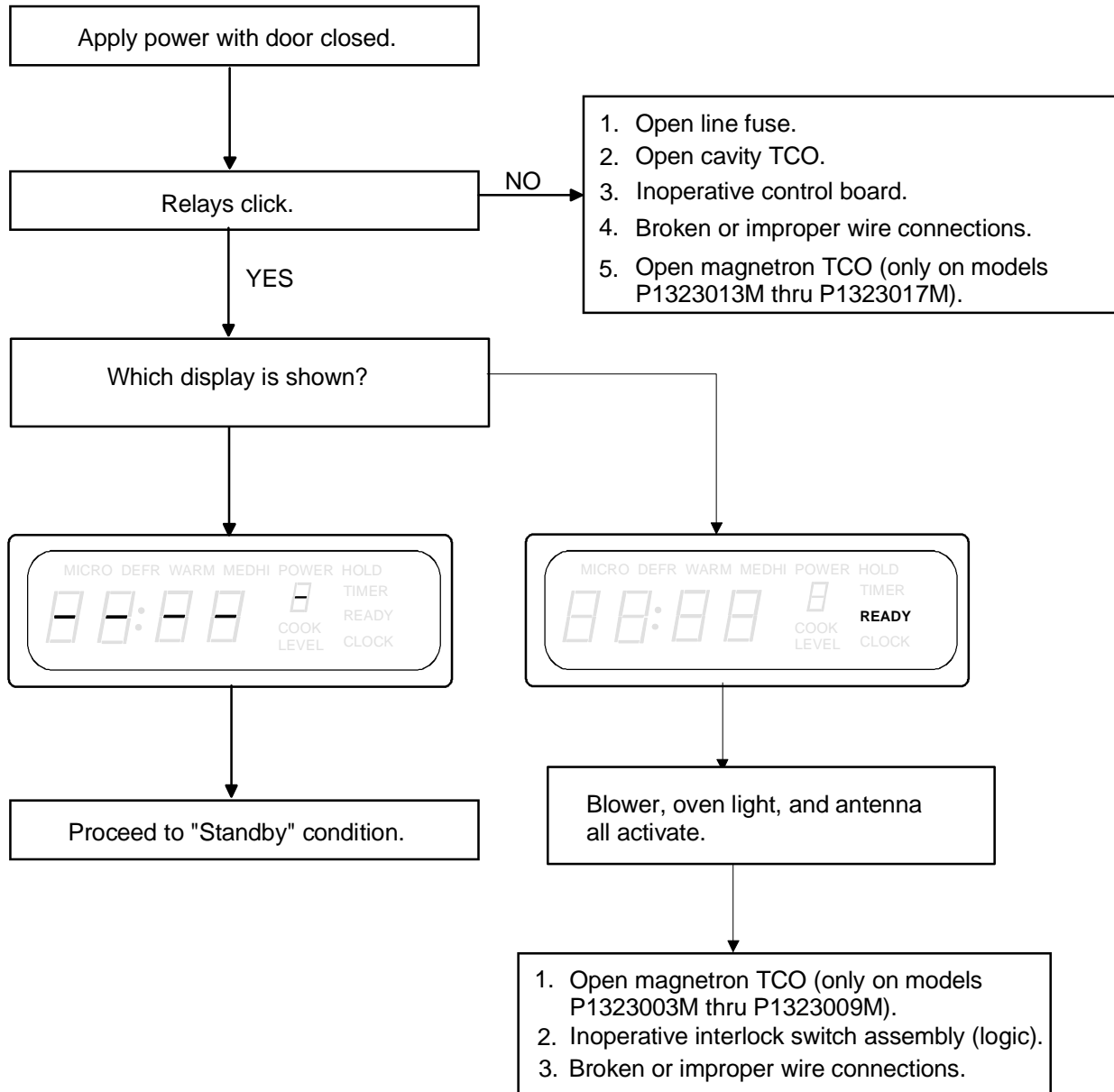

Troubleshooting

Standby Condition

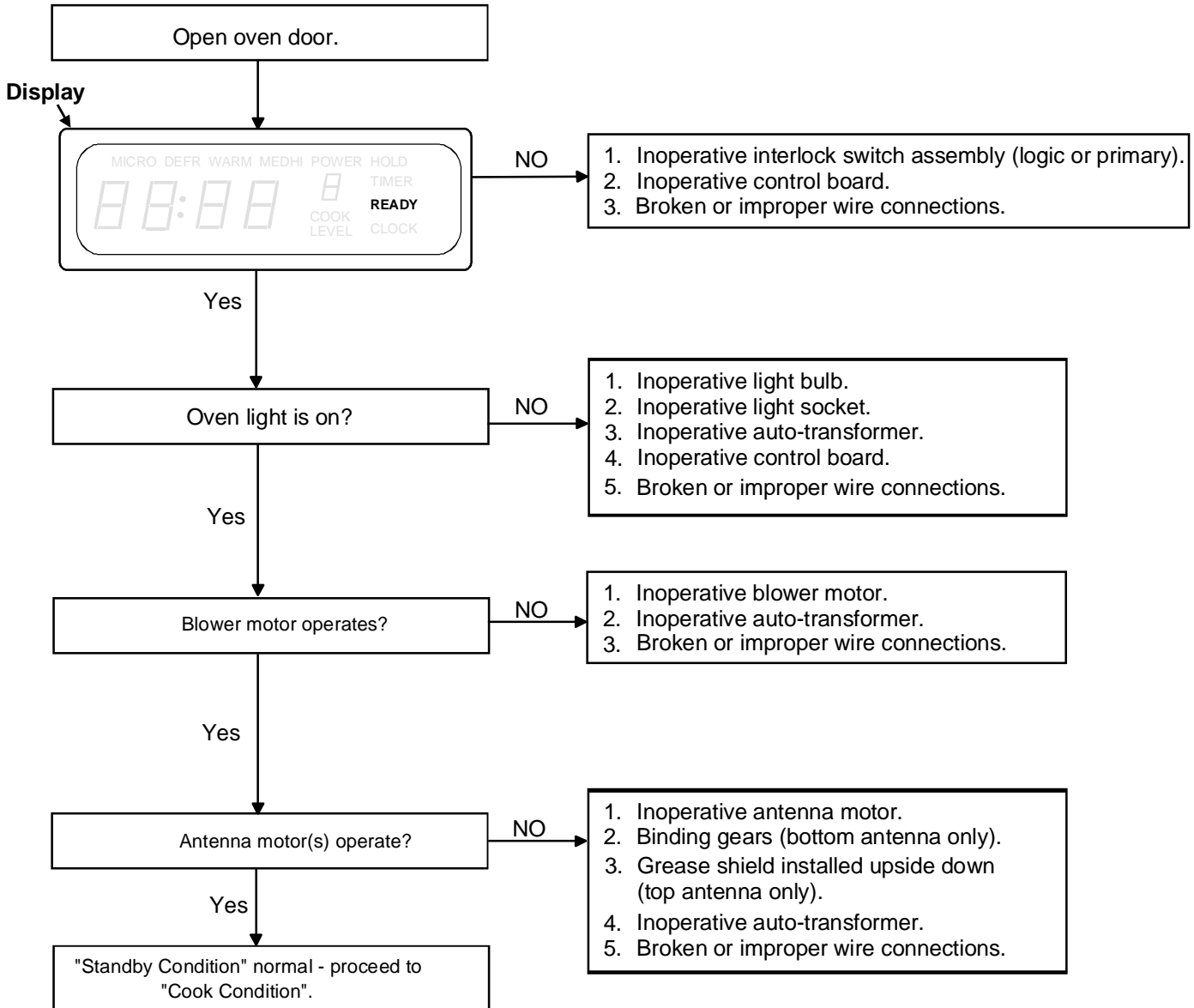

Troubleshooting

Cook Condition

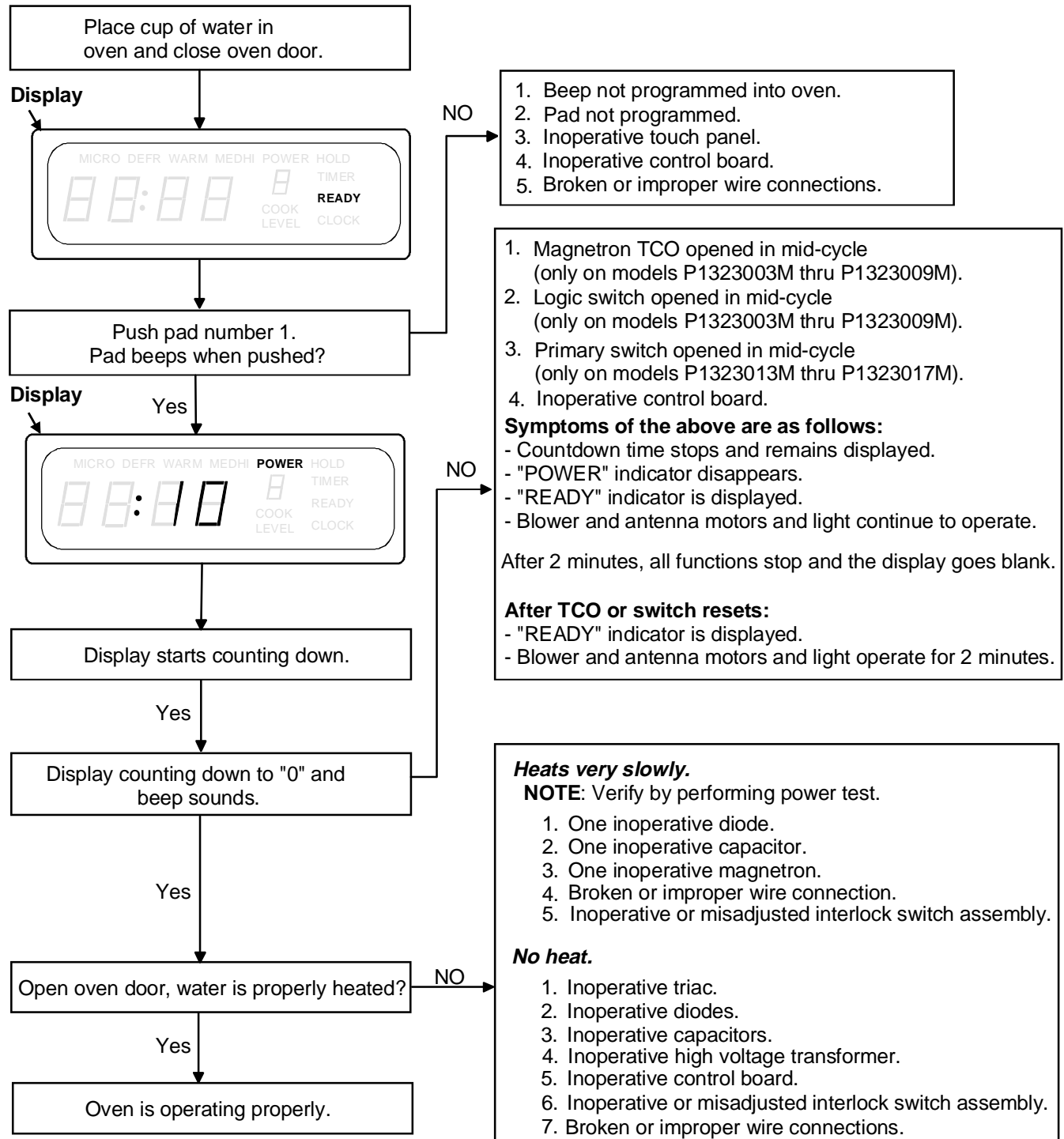

NOTE: Shut down after cook cycle - door closed - factory preset at 60 seconds, but can be changed with user options. Shut down, door open - approximately 2 minutes. After shut down, display goes blank.

Disassembly

WARNING

To avoid the risk of electrical shock, personal injury, or death, disconnect power to oven and discharge capacitors before following any disassembly procedure.

Door Removal

1. Unplug power cord from power source.
2. Remove outer case cover.
3. Remove bolts securing door hinges.
4. Remove door from unit, and lay door on padded surface.

Inner Door/Window Removal

1. Open oven door.
2. Remove screws on hinge side.
3. Beginning at the bottom, carefully insert 1" putty knife between inner and outer door. Pry up on inner door to release tabs, (2 tabs per side). Work in a clockwise direction to release all tabs, see illustration below.

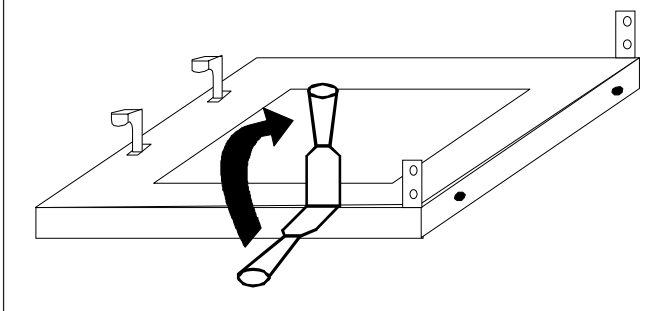
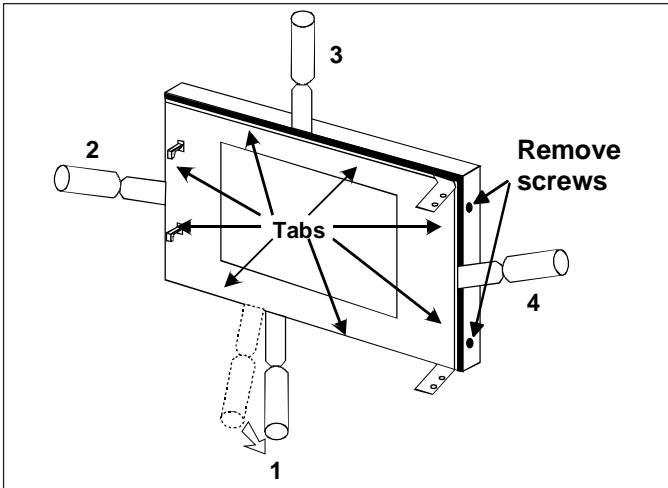

CAUTION

When glass retainer is removed, be careful glass does not fall out of frame.

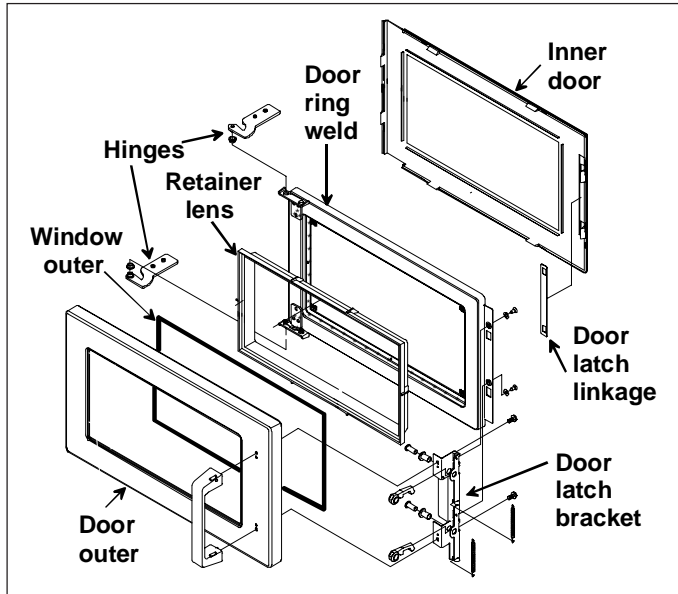

Door Disassembly

1. Remove door from oven, see "Door Removal" procedure.
2. Perform "Inner Door/Window Removal" procedures, step 1 through step 3 above.
3. Remove door latch linkage plate from latch assembly.
4. Remove screws securing door ring weld, (2 screws under latch linkage and 2 on hinge side of outer door).
5. Remove door ring weld from door.
6. Remove lens retainer and outer window from door.
7. Remove screws securing handle/door latch bracket to gain access to latch spring.
8. Reassemble in reverse order.
9. Proceed to "Interlock Switch Replacement / Door Adjustment" procedure.

Door Handle

1. Follow "Door Disassembly" procedure through step 6.
2. Remove screws securing latch assembly to outer door.
3. Reassemble in reverse order.

Hinge

1. Follow Door Disassembly procedure through step 6.
2. Replace hinge on door ring weld.
3. Reassemble in reverse order.

Disassembly



To avoid the risk of electrical shock, personal injury, or death, disconnect power to oven and discharge capacitors before following any disassembly procedure.

Interlock Switch Assembly

1. See "Component Location" Figure 1, for location.
2. Unplug power cord from power source.
3. Remove outer case.
4. Disconnect wiring.
5. Remove screws securing switch assembly to unit.
6. Install new switch assembly.
7. Install screws but do not tighten.
8. Proceed to "Door/Interlock Switch Adjustment" procedure.

NOTE: When the line fuse is blown replace interlock switch assembly.

R0150154 Early Production Switch

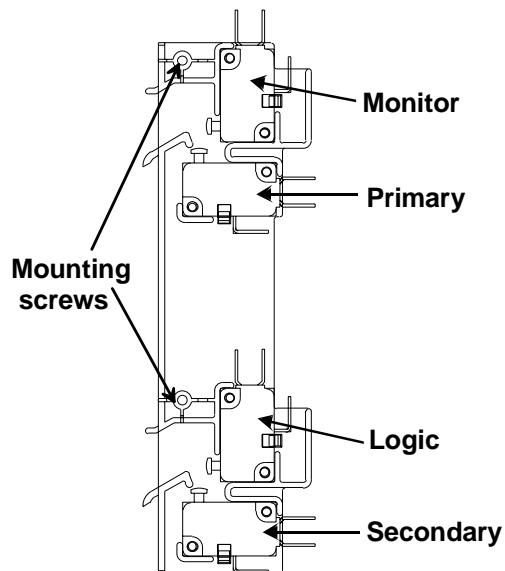

R0000277 Replacement for Early Production Switch

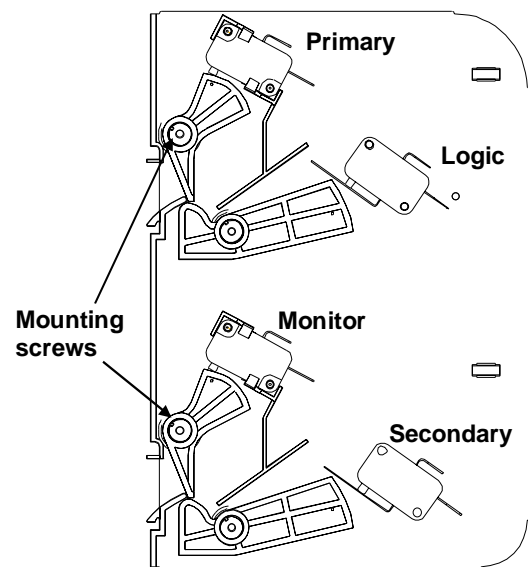

12538901Q Later Production Switch

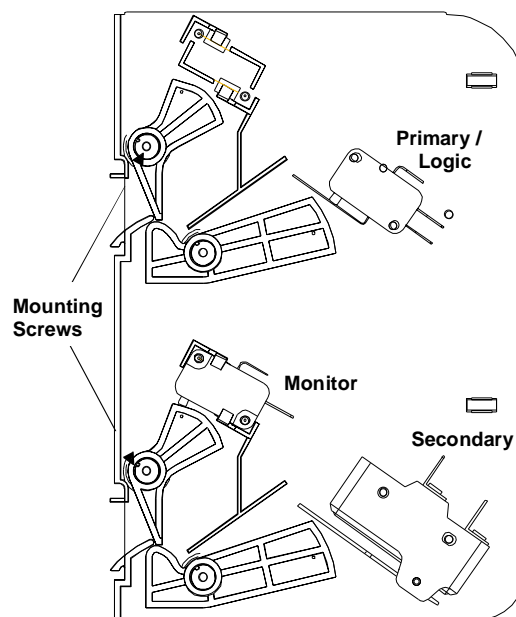

Disassembly

WARNING

To avoid the risk of electrical shock, personal injury, or death, disconnect power to oven and discharge capacitors before following any disassembly procedure.

Switch Replacement / Door Adjustment

WARNING

To avoid risk of electrical shock, personal injury or death; disconnect electrical power before servicing.

1. Remove and retain two (2) screws securing switch to cavity. Remove switch.
2. Position new switch assembly into cavity opening.
 - First, insert bottom ramp of switch into bottom opening.
 - Tilt switch upward and insert top ramp of switch into top opening.
 - Be sure both ramps are fully protuded through the front frame of cavity.

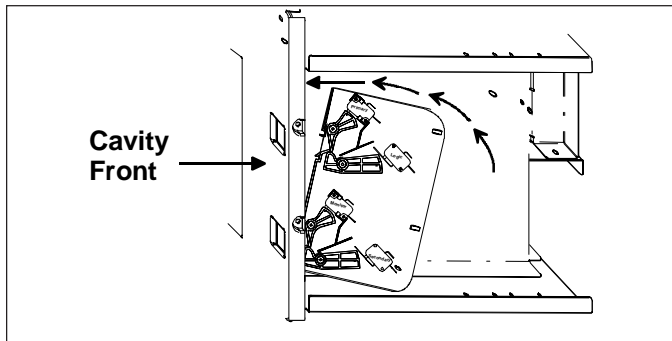

3. Loosely install screws removed in step 1.
4. Push and hold switch assembly towards front of oven and tighten screws.
5. Transfer wires to new switch.
6. **Install wire ties as indicated. All wire ties must be installed.**

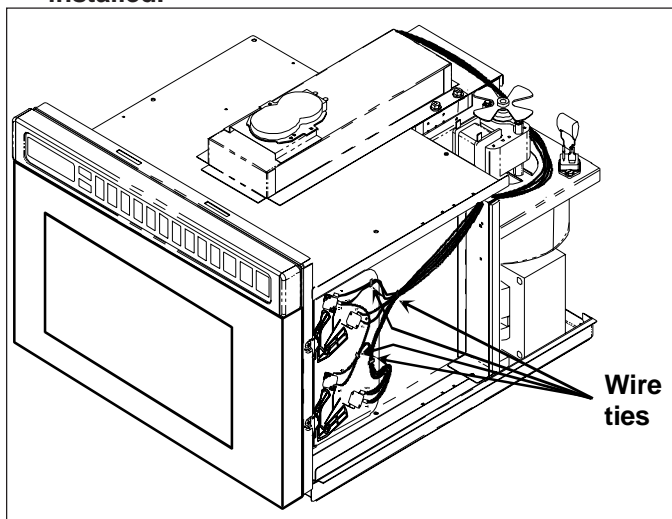

Important: It is necessary to adjust the door assembly for correct switch function.

7. Tape shims **12382602** and 12019302 to door, as shown.

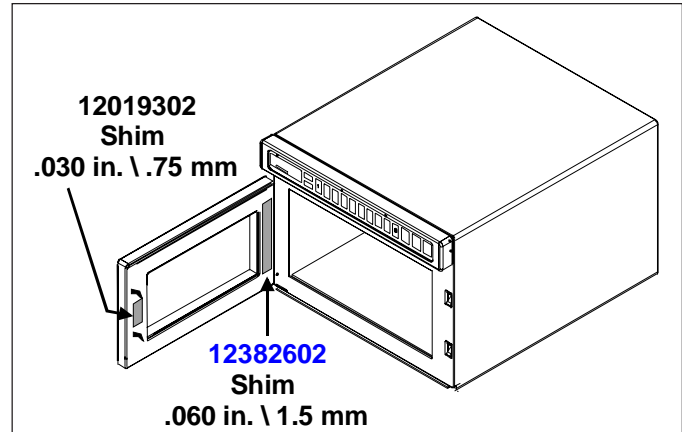

8. With door closed, loosen door hinge bolts 1/2 turn.
9. Lift upward on door, using the door handle.
10. With left hand, clamp door to cavity on hinge side of door.
11. While holding door in place, tighten hinge bolts in the order shown.

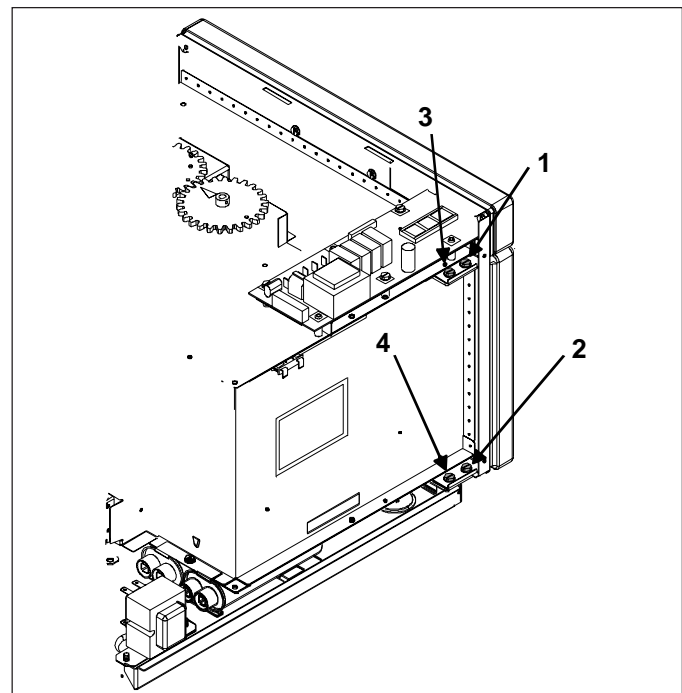

12. Open and close door several times to check switch operation.

NOTE: If switches do not activate, check condition and alignment of door and hinges.

13. Remove shims.

Disassembly

WARNING

To avoid the risk of electrical shock, personal injury, or death, disconnect power to oven and discharge capacitors before following any disassembly procedure.

Outer Case

1. Remove screws securing outer case to chassis.
2. Slide outer case back and lift off.
3. Reassemble outer case in reverse order.

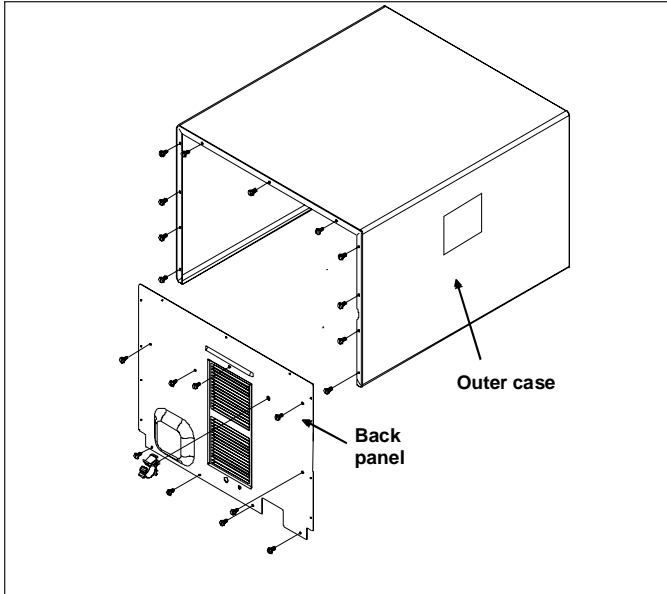

Back Panel

1. Remove outer case.
2. Remove screws securing back panel.
3. Reassemble back panel in reverse order.

Grease Shield

See "Component Location" Figure 1, for location.

- Remove shield, place fingers between shield and back wall of cavity, pull forward and down to release tabs from back wall.

Antenna Assembly–Top

1. See "Component Location" Figure 2, for location.
2. Unplug power cord from power source.
3. Remove grease shield.
4. Using needle nose pliers, grasp antenna hub and pull downward to remove antenna from shaft.
5. Using needle nose pliers, grasp antenna clip and pull downward to remove clip from shaft.

NOTE: During the remaining steps, use caution when handling antenna to prevent antenna damage.

6. To reinstall antenna, insert clip into antenna hub.
7. Push antenna assembly over motor shaft until antenna bottoms out on shaft collar.

Antenna Motor–Top

1. See "Component Location" Figure 2, for location.
2. Remove top antenna, see "Antenna Assembly–Top" procedure steps 1 through 5.

3. Disconnect and label wires from motor.
4. Remove screws securing motor to cavity and remove motor.
5. Reassemble in reverse order.

Oven Tray Removal

See "Component Location" Figure 1, for location.

1. Using a utility knife, cut RTV seal around perimeter of tray.
2. Using a heat gun, apply heat to front lip of tray to release hot melt glue.
3. Pry upward on front lip of tray and remove.
4. Thoroughly remove all traces of old RTV and degrease the tray, cavity bottom, walls, and front flange.
5. Place tray in center of cavity. Do not allow tray to touch side walls.
6. Apply a generous bead of RTV sealant around perimeter of tray.
7. Apply a light water spray to the fresh RTV sealant.
8. Using RTV scrapper, Amana part # [R0000039](#), remove excess RTV.

NOTE: Allow RTV to set for 1 hour before using.

Antenna Assembly–Bottom

See "Component Location" Figure 2, for location.

1. Remove ceramic tray.
2. Lay oven on its left side and open door.
3. Remove bottom access cover.
4. Insert flat blade screwdriver under gear and pry gear from antenna shaft. Discard old gear and washer.
5. Inside cavity, pull antenna / shaft assembly to remove from cavity. Save old antenna to assist with installation of new shaft.
6. Slide new retainer over new shaft.
7. Push old antenna over shaft and retainer.
8. Push antenna / shaft assembly into cavity hole.
9. With raised rib on edge of washer facing away from cavity, push washer over shaft.
10. With raised rib on gear facing towards cavity, press gear over shaft end tabs until gear snaps into place ("D" shaft).
11. Remove old antenna from shaft.

NOTE: During remaining steps, use caution when handling antenna to prevent antenna damage.

12. Push new antenna over retainer and shaft until antenna bottoms out on shaft collar.
13. Re-install bottom access cover and place oven in upright position.
14. With door open, plug-in oven and observe antenna operation. Antenna blade should be level with cavity bottom.

Reseal ceramic tray using RTV sealant and scraper (supplied).

Disassembly



To avoid the risk of electrical shock, personal injury, or death, disconnect power to oven and discharge capacitors before following any disassembly procedure.

Antenna Motor–Bottom

See “Component Location” Figure 2, for location.

1. Remove original retaining clip from motor shaft and remove gear. Discard retaining clip and gear.
2. Remove screws securing motor to cavity and remove motor.
3. Disconnect wires from old motor and install on new motor.
4. Secure new motor to cavity.
5. With raised rib on gear towards motor, install gear over motor shaft.
6. Install snap ring into groove on motor shaft.

Touch Panel Assembly

1. See “Component Location” Figure 1, for location.
2. Unplug power cord from power source.
3. Remove outer case.
4. Remove ribbon pin connector from control board.
5. Remove screws securing touch panel to cavity.
6. Reassemble touch panel in reverse order.

Control Board

1. See “Component Location” Figure 3, for location.
2. Remove outer case.
3. Disconnect and label ribbon pin connector, and wires.
4. Remove screws securing control board to cavity and remove board.
5. Reassemble in reverse order.



To avoid radiation leakage perform microwave energy leakage test.

Magnetron Cutout (TCO)

1. See “Component Location” Figure 3, for location.
2. Unplug power cord from power source.
3. Remove outer case.
4. Remove wiring from selected cutout.
5. Remove screws securing cutout.
6. Reassemble cutout in reverse order.

Triac

1. See “Component Location” Figure 3, for location.
2. Unplug power cord from power source.
3. Remove outer case.
4. Remove wires from terminals of triac.
5. Remove screws securing triac to blower bracket.
6. Reassemble triac in reverse order.

Diodes

1. See “Component Location” Figure 1, for location.
2. Unplug power cord from power source.
3. Remove outer case.
4. Remove screw securing diode bracket to chassis.
5. Remove screws securing diodes to bracket.
6. Replace diodes and reassemble in reverse order.

Magnetron

1. See “Component Location” Figure 2, for location.
2. Unplug power cord from power source.
3. Remove outer case and back panel.
4. Using knife, cut tape in 4 areas shown below.

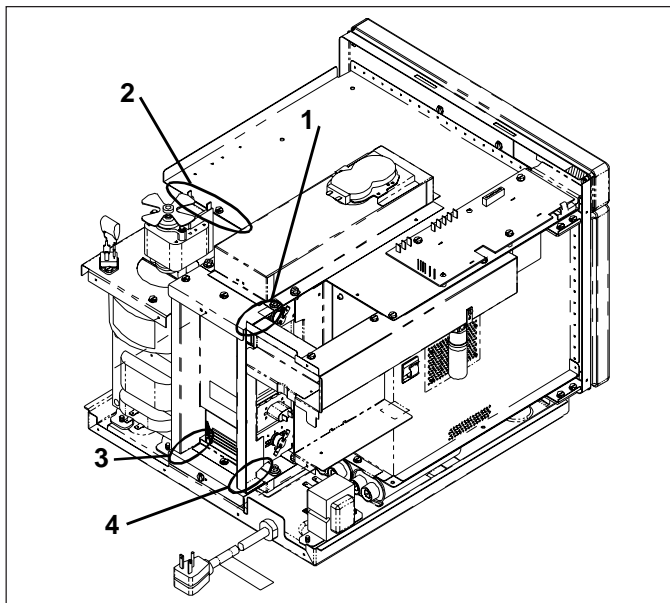

5. Remove screw securing exhaust duct and slide duct 1/2" (1.2 cm) to the right, (see # 1 below).
6. Remove screws securing blower mounting bracket and slide blower assembly to the left, (see # 2 below).
7. Remove screws securing outlet duct assembly and remove duct, (see # 3 below).
8. Carefully remove flow divider to gain access to magnetron.
9. Remove wires from magnetron being removed.
10. Remove nuts securing magnetron and remove magnetron.

Disassembly

WARNING

To avoid the risk of electrical shock, personal injury, or death, disconnect power to oven and discharge capacitors before following any disassembly procedure.

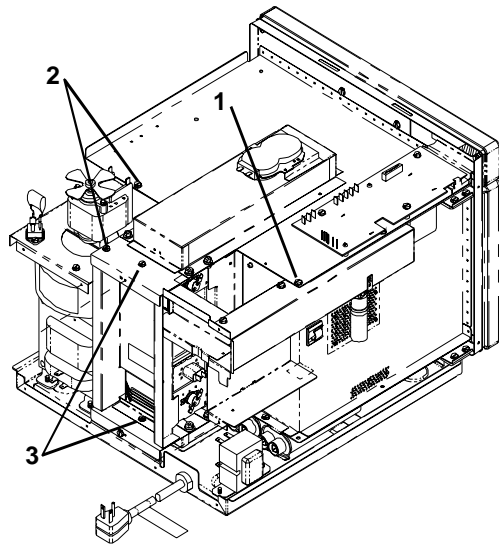

Remove duct work screws in sequence shown.

NOTE: When replacing magnetron, verify wire mesh gasket is reinstalled properly.

Cavity Thermal Cutout Replacement

1. See "Component Location" Figure 3, for location.
2. Remove outer case.
3. Remove control board mounting screws.
4. Slide controller towards center of oven. **Do not remove.**
5. Remove exhaust duct mounting screws.
6. Remove thermal fuse mounting screw.
7. Replace thermal fuse, and reassemble in reverse order.

Fuse

1. See "Component Location" Figure 3, for location.
2. Unplug power cord from power source.
3. Remove outer case.
4. Replace fuse and reassemble in reverse order.

NOTE: When replacing fuse, interlock switch assembly must be replaced.

Blower Wheel and Motor

1. Unplug power cord from power source.
2. Remove outer case and back panel.
3. Remove wiring from blower motor terminals.
4. Remove screws securing blower mounting bracket.
5. Remove blower assembly and bracket from oven.
6. Remove screws securing scroll to mounting bracket.
7. Loosen allen set screw securing blower wheel to motor shaft.
8. Remove blower wheel.
9. Remove screws securing motor to mounting bracket.
10. Reassemble blower wheel and motor in reverse order.

NOTE: When reinstalling blower wheel, push blower wheel on shaft, tighten, and rotate to insure clearance between blower wheel, and blower housing.

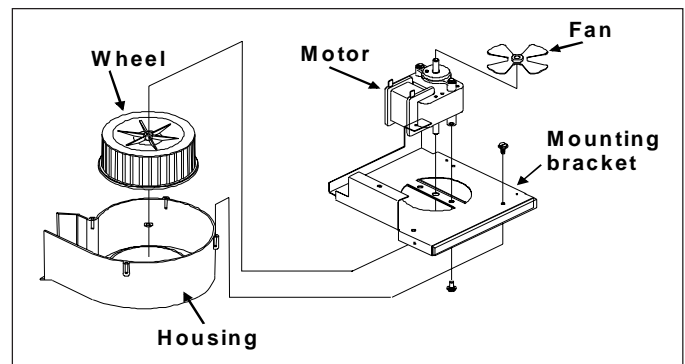

Fan Blade

1. See prior illustration for location.
2. Pull blade off shaft.
3. When reinstalling blade, push blade on shaft and rotate to insure clearance between fan blade and wire terminals.

Auto Transformer

1. See "Component Location" Figure 3, for location.
2. Unplug power cord from power source.
3. Remove outer case and back panel.
4. Remove screws securing auto transformer to chassis.
5. Remove wire connections from auto transformer.
6. Reassemble auto transformer in reverse order.

Disassembly

WARNING

To avoid the risk of electrical shock, personal injury, or death, disconnect power to oven and discharge capacitors before following any disassembly procedure.

High Voltage Transformer

1. See "Component Location" Figure 3, for location.
2. Unplug power cord from power source.
3. Remove outer case and back panel.
4. Remove screws securing transformer to chassis.
5. Pry upward and back to release transformer from chassis.
6. Remove wire connections from transformer.
7. Reassemble transformer in reverse order.

Capacitor

1. See "Component Location" Figure 3, for location.
2. Unplug power cord from power source.
3. Remove outer case and back panel.
4. Remove screws securing auto transformer to chassis.
5. Discharge capacitor and remove wires from terminals.
6. Remove capacitor bracket mounting screw.
7. Reassemble capacitor in reverse order.

Power Cord

1. See "Component Location" Figure 3, for location.
2. Unplug power cord from power source.
3. Remove outer case and back panel.
4. Disconnect wiring.
5. Remove strain relief by compressing with pliers.
6. Remove power cord.
7. Reassemble power cord in reverse order.

Lamp Receptacle

1. See "Component Location" Figure 3, for location.
2. Unplug power cord and remove lamp access panel.
3. Unscrew lamp from receptacle.
4. Disconnect wire terminals to receptacle.
5. Drill out rivet securing receptacle to exhaust duct.
6. Reassemble receptacle in reverse order.

Replacing Oven Lamp

WARNING

To avoid electrical shock which can cause severe personal injury or death, unplug power cord or open circuit breaker to oven before replacing lamp. After replacing lamp, restore power.

CAUTION

To avoid personal injury or property damage, observe the following:

- Allow oven and lamp to cool.
- Wear gloves when replacing lamp.

Tools Needed

- Protective gloves
- Screwdriver
- 25-watt, 120-volt appliance bulb (available from authorized distributor or servicer)

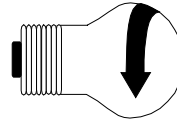

To remove lamp, turn in direction shown.

1. Remove screws from access cover on side panel of oven exterior.
2. Remove old lamp and replace with new lamp.
3. Replace access cover and screw by reversing procedure in step 1.

Disassembly

WARNING

To avoid the risk of electrical shock, personal injury, or death, disconnect power to oven and discharge capacitors before following any disassembly procedure.

Component Location

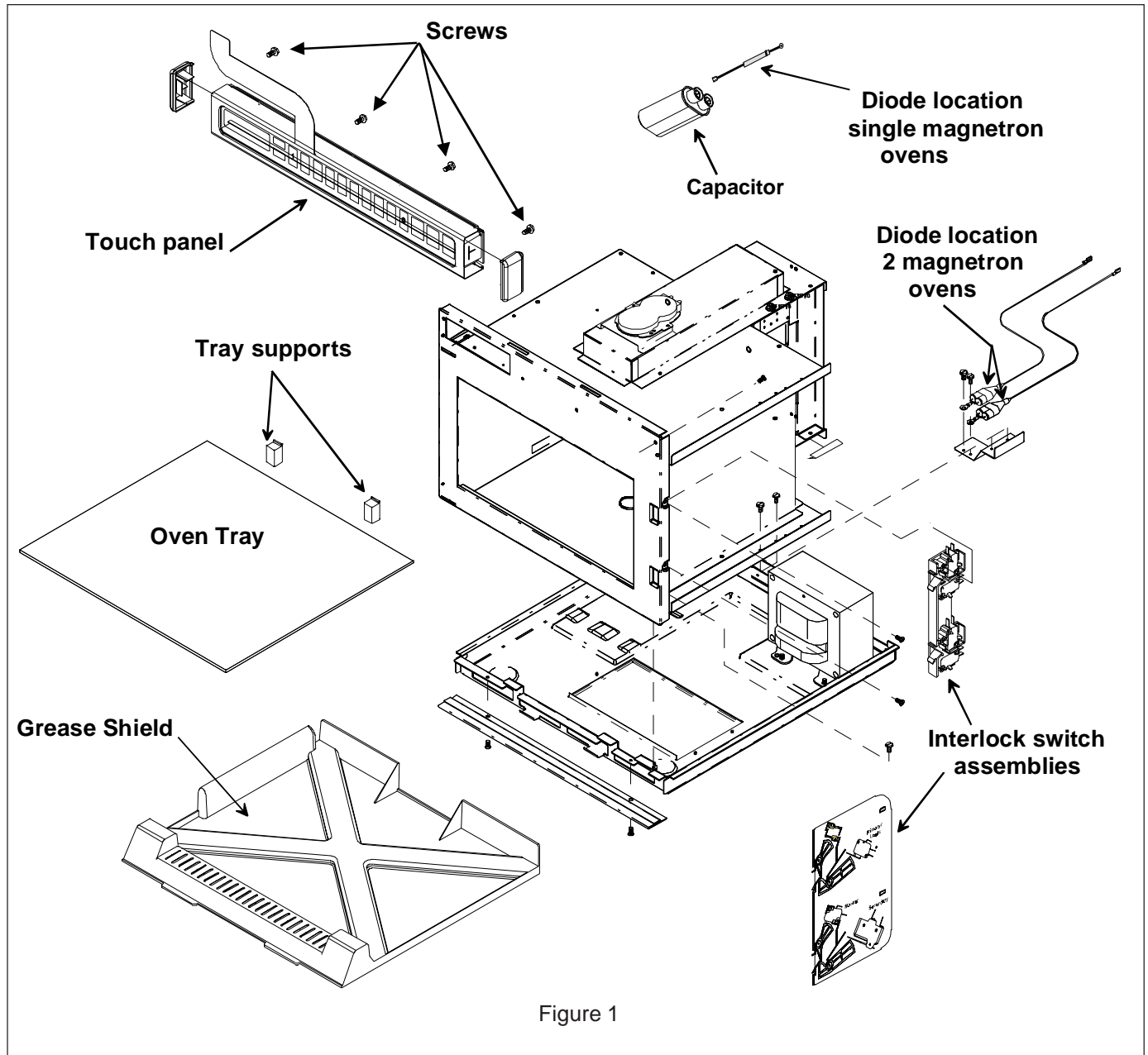

Disassembly

 **WARNING**

To avoid the risk of electrical shock, personal injury, or death, disconnect power to oven and discharge capacitors before following any disassembly procedure.

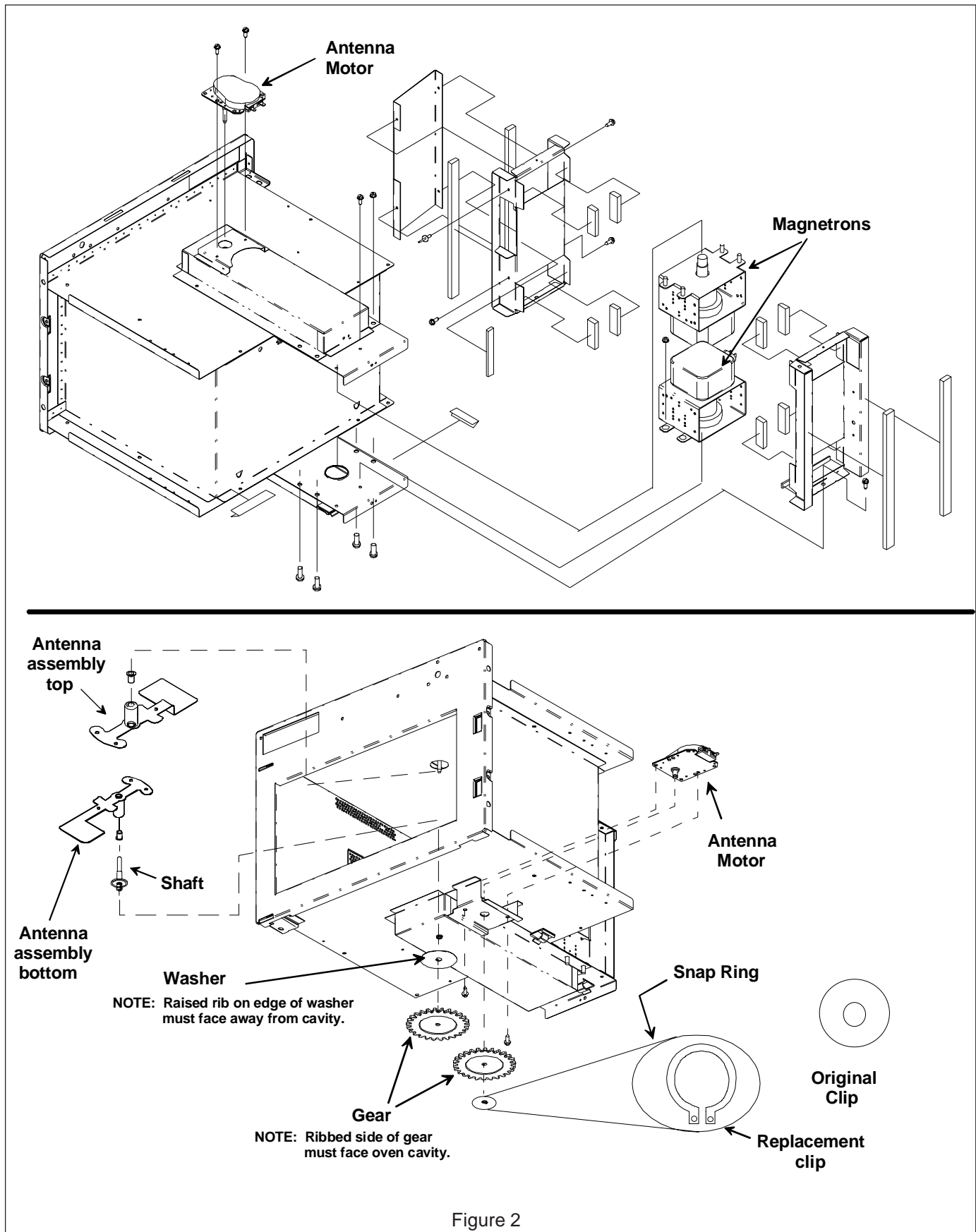
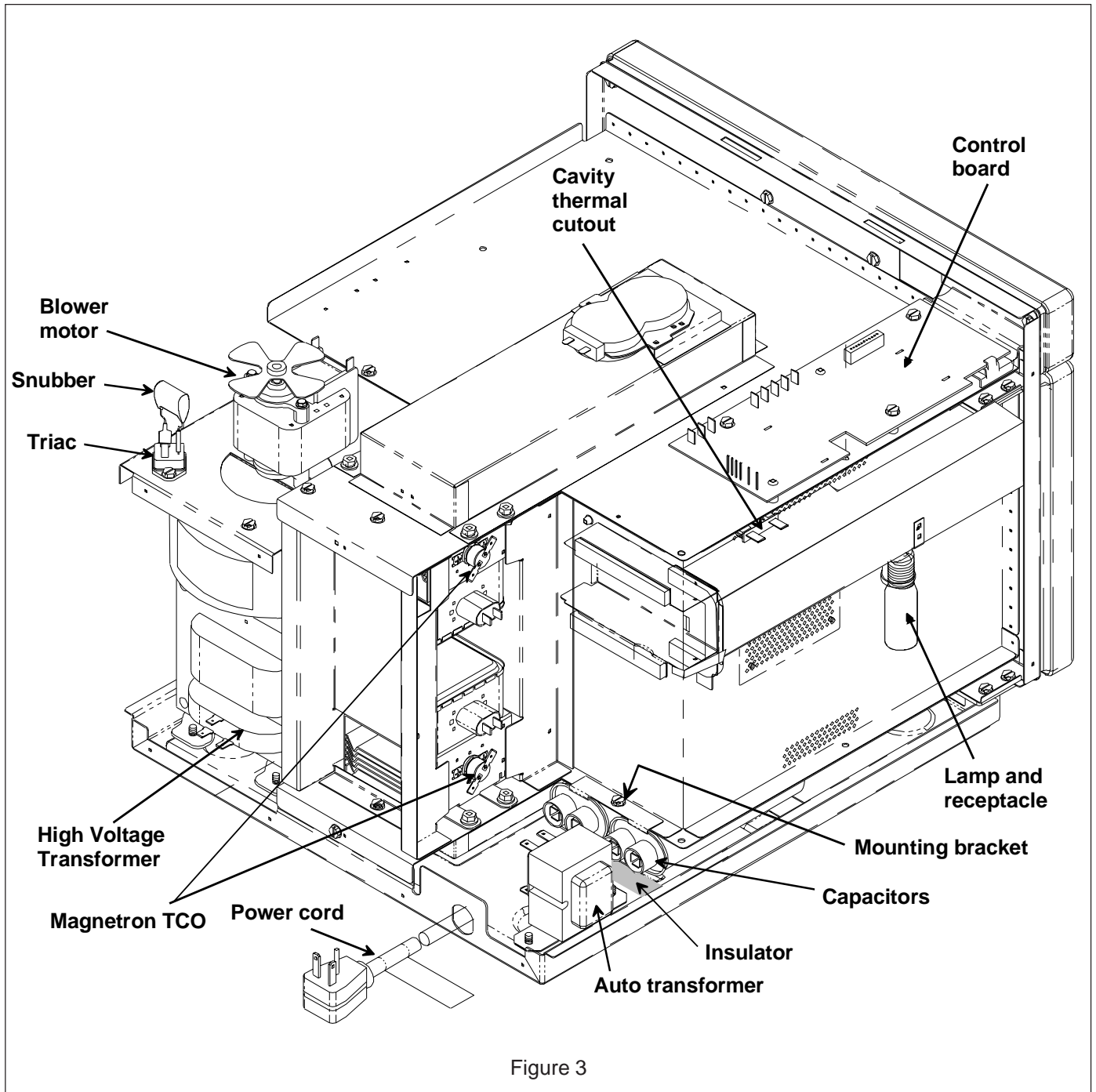

Figure 2

Disassembly

 **WARNING**

To avoid the risk of electrical shock, personal injury, or death, disconnect power to oven and discharge capacitors before following any disassembly procedure.



Appendix A

Amana[®]

Owner's Manual

Commercial Microwave Oven

HDC21*

HDC18*

HDC12*

HDC10*

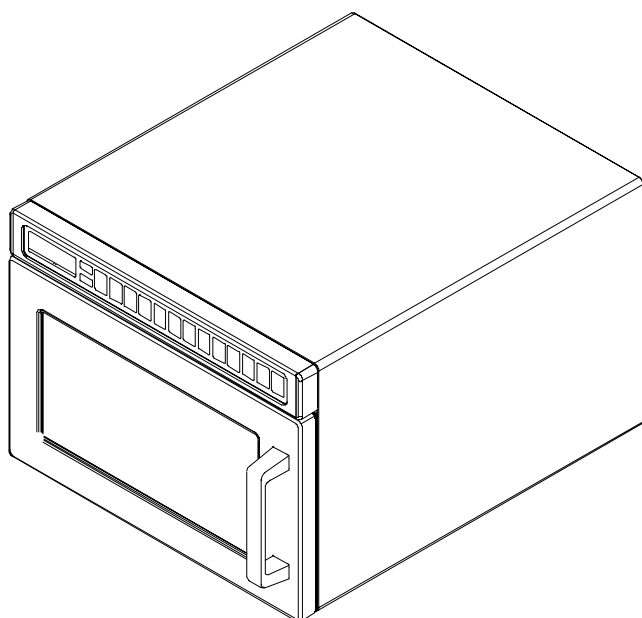

* Additional alphanumeric characters representing other models in the series may follow each model number.

Keep these instructions for future reference. If the oven changes ownership, be sure this manual accompanies oven.

Contents

Model Identification	2
IMPORTANT SAFETY INSTRUCTIONS	3
PRECAUTIONS TO AVOID POSSIBLE EXPOSURE TO EXCESSIVE MICROWAVE ENERGY	4
Grounding Instructions	7
Installation	8
Features	10
Control Panel Features	11
Cooking Methods	12
Displays	13
Operation	14
Programming	15
Cooking Guidelines	18
Care and Cleaning	20
Before Calling for Service	22
Quick Reference Instructions	24

Model Identification

Complete enclosed registration card and promptly return.
If registration card is missing, call Consumer Affairs
Department at 1-800-843-0304 inside U.S.A.
1-319-622-5511 outside U.S.A.

When contacting Amana, provide product information.
Product information is located on oven serial plate.
Record the following information:

Model Number: _____
Manufacturing Number: _____
Serial or S/N Number: _____
Date of purchase: _____
Dealer's name and address: _____

Keep a copy of sales receipt for future reference or in
case warranty service is required.

Any questions or to locate an authorized servicer, call
1-800-843-0304 inside U.S.A. 1-319-622-5511 outside
U.S.A. If an automated telephone system is reached,
select Commercial Microwave Ovens category. Warranty
service must be performed by an authorized servicer.
Amana also recommends contacting an authorized
servicer if service is required after warranty expires.

IMPORTANT SAFETY INSTRUCTIONS



Recognize this symbol as a **SAFETY** message



WARNING

When using electrical oven, basic safety precautions should be followed to reduce the risk of burns, electric shock, fire, or injury to persons or exposure to excessive microwave energy.

1. READ all instructions before using oven.
2. READ AND FOLLOW the specific "PRECAUTIONS TO AVOID POSSIBLE EXPOSURE TO EXCESSIVE MICROWAVE ENERGY" on page 4.
3. This oven **MUST BE GROUNDED**. Connect only to properly GROUNDED outlet. See "GROUNDING INSTRUCTIONS" on page 7.
4. Install or locate this oven **ONLY** in accordance with the installation instructions in this manual.
5. Some products such as whole eggs and sealed containers – for example, closed glass jars – may explode and **SHOULD NOT** be HEATED in this oven.
6. Use this oven **ONLY** for its intended use as described in this manual. Do not use corrosive chemicals or vapors in this oven. This type of oven is specifically designed to heat or cook. It is not designed for industrial or laboratory use.
7. As with any oven, **CLOSE SUPERVISION** is necessary when used by **CHILDREN**.
8. **DO NOT** operate this oven if it has a damaged cord or plug, if it is not working properly, or if it has been damaged or dropped.
9. This oven, including power cord, must be serviced **ONLY** by qualified service personnel. Special tools are required to service oven. Contact nearest authorized service facility for examination, repair, or adjustment.
10. **DO NOT** cover or block filter or other openings on oven.
11. **DO NOT** store this oven outdoors. **DO NOT** use this product near water – for example, near a kitchen sink, in a wet basement, or near a swimming pool, and the like.
12. **DO NOT** immerse cord or plug in water.
13. Keep cord **AWAY** from **HEATED** surfaces.
14. **DO NOT** let cord hang over edge of table or counter.
15. See door cleaning instructions in "Care and Cleaning" section of manual on page 20.
16. For commercial use only.



WARNING

To reduce the risk of fire in the oven cavity:

- a. **DO NOT** overcook food. Carefully attend oven if paper, plastic, or other combustible materials are placed inside the oven to facilitate cooking.
- b. Remove wire twist-ties from paper or plastic bags before placing bag in oven.
- c. **KEEP** oven **DOOR CLOSED**, turn oven off, and disconnect the power cord, or shut off power at the fuse or circuit breaker panel, if materials inside the oven should ignite. Fire may spread if door is opened.
- d. **DO NOT** use the cavity for storage. **DO NOT** leave paper products, cooking utensils, or food in the cavity when not in use.

SAVE THESE INSTRUCTIONS

IMPORTANT SAFETY INSTRUCTIONS



CAUTION

To avoid personal injury or property damage, observe the following:

1. Briskly stir or pour liquids before cooking with microwave energy to prevent spontaneous boiling or eruption. Do not overheat. If air is not mixed into a liquid, liquid can erupt in oven or after removal from oven.
2. Do not deep fat fry in oven. Fat could overheat and be hazardous to handle.
3. Do not cook or reheat eggs in shell or with an unbroken yolk using microwave energy. Pressure may build up and erupt. Pierce yolk with fork or knife before cooking.
4. Pierce skin of potatoes, tomatoes, and similar foods before cooking with microwave energy. When skin is pierced, steam escapes evenly.
5. Do not operate oven without load or food in oven cavity.
6. Use only popcorn in packages designed and labeled for microwave use. Popping time varies depending on oven wattage. Do not continue to heat after popping has stopped. Popcorn will scorch or burn. Do not leave oven unattended.
7. Do not use regular cooking thermometers in oven. Most cooking thermometers contain mercury and may cause an electrical arc, malfunction, or damage to oven.
8. Do not heat baby bottles in oven.
9. Do not use metal utensils in oven.
10. Never use paper, plastic, or other combustible materials that are not intended for cooking.
11. When cooking with paper, plastic, or other combustible materials, follow manufacturer's recommendations on product use.
12. Do not use paper towels which contain nylon or other synthetic fibers. Heated synthetics could melt and cause paper to ignite.
13. Do not heat sealed containers or plastic bags in oven. Food or liquid could expand quickly and cause container or bag to break. Pierce or open container or bag before cooking.
14. To avoid pacemaker malfunction, consult physician or pacemaker manufacture about effects of microwave energy on pacemaker.

PRECAUTIONS TO AVOID POSSIBLE EXPOSURE TO EXCESSIVE MICROWAVE ENERGY

- a. DO NOT attempt to operate this oven with door open since open-door operation can result in harmful exposure to microwave energy. It is important not to defeat or tamper with safety interlocks.
- b. DO NOT place any object between oven front face and door or allow soil or cleaner residue to accumulate on sealing surfaces.
- c. DO NOT operate oven if it is damaged. It is particularly important that oven door close properly and that there is no damage to: (1) door (bent), (2) hinges and latches (broken or loosened), (3) door seals and sealing surfaces.
- d. Oven should NOT be adjusted or repaired by anyone except properly qualified service personnel.

SAVE THESE INSTRUCTIONS

MESURES DE SECURITE IMPORTANTES



Ce symbole signale un message de SECURITE



DANGER

Lors de l'utilisation d'appareils électriques, prendre les précautions élémentaires suivantes pour réduire les risques de brûlures, d'électrocution, d'incendie, de blessures ou d'exposition à un excès de micro-ondes.

1. **LIRE** la totalité des instructions avant d'utiliser le four.
2. **LIRE ET SUIVRE** les **PRECAUTIONS CONTRE LES RISQUES D'EXPOSITION A UN EXCES DE MICRO-ONDES**, page 6.
3. Ce four **DOIT ETRE MIS A LA TERRE**. Le brancher uniquement sur une prise correctement reliée à la terre. Voir les **INSTRUCTIONS DE MISE A LA TERRE**, page 7.
4. Mettre en service ou placer ce four **UNIQUEMENT** tel qu'indiqué dans les instructions de mise en service fournies dans ce manuel.
5. Certains aliments ou articles comme les oeufs et les récipients fermés hermétiquement tels que les bocaux, par exemple, peuvent exploser et **NE DOIVENT PAS ETRE UTILISES** dans ce four.
6. Utiliser ce four **UNIQUEMENT** pour les usages pour lesquels il est prévu, décrits dans ce manuel. Ne pas utiliser de vapeurs ni de produits chimiques corrosifs dans cet appareil. Ce type de four est spécifiquement conçu pour faire chauffer ou cuire les aliments. Il n'est pas prévu pour un usage industriel ou en laboratoire.
7. Comme pour tout autre appareil électrique, l'utilisation de cet appareil par les **ENFANTS** doit se faire **SOUS ETROITE SURVEILLANCE**.
8. **NE PAS** utiliser le four si la prise ou le cordon électrique est abîmé, si le four ne fonctionne pas correctement ou si l'appareil est tombé ou a été endommagé.
9. Cet appareil, cordon électrique compris, doit être réparé **UNIQUEMENT** par un technicien qualifié. Des outils spéciaux sont nécessaires à cette fin. Contacter le prestataire de service après-vente agréé le plus proche pour le faire examiner, réparer ou régler.
10. **NE PAS** couvrir ni boucher le filtre ni aucun orifice du four.
11. **NE PAS** placer cet appareil à l'extérieur. **NE PAS** l'utiliser près d'un endroit où il y a de l'eau, comme dans un sous-sol humide, près d'un évier ou d'une piscine ou en tout autre endroit similaire.
12. **NE PAS** plonger le cordon électrique ou la prise dans l'eau.
13. Garder le cordon électrique **A DISTANCE SURE** de surfaces **CHAUFFEES**.
14. **NE PAS** laisser le cordon pendre d'une table ou d'un comptoir.
15. Voir la marche à suivre pour l'entretien de la porte sous "*Entretien de l'extérieur du four*" dans la partie "*Entretien*" du manuel, page 20.
16. **Pour usage commercial uniquement.**



DANGER

Pour réduire les risques d'incendie à l'intérieur du four :

- a. **NE PAS** trop cuire les aliments. Surveiller attentivement la cuisson si du papier, du plastique ou tout autre matériau combustible est utilisé pour faciliter la cuisson.
- b. Enlever toute attache métallique servant à fermer les sacs en plastique ou en papier avant de placer le sac dans le four.
- c. Si le feu prend dans le four, **LAISSER LA PORTE** du four **FERMEE**, éteindre le four et le débrancher ou couper le courant au niveau du fusible ou du disjoncteur. Si la porte du four est ouverte, l'incendie peut se propager.
- d. **NE PAS** utiliser l'intérieur du four comme espace de rangement. **NE PAS** laisser d'articles en papier, de récipients, d'ustensiles de cuisson nid'aliments dans le four pendant qu'il n'est pas utilisé.

CONSERVER CES INSTRUCTIONS

MESURES DE SECURITE IMPORTANTES



ATTENTION

Pour éviter tous dégâts matériels ou blessures, observer les consignes suivantes :

1. Pour éviter toute ébullition ou éruption spontanée, remuer vigoureusement ou verser les liquides avant de les chauffer au four à micro-ondes. Ne pas trop chauffer. Si de l'air n'a pas été incorporé dans le liquide, celui-ci peut déborder dans le four ou après en avoir été retiré.
2. Ne pas faire de friture dans le four. La graisse pourrait surchauffer et devenir dangereuse à manipuler.
3. Les oeufs ne doivent pas être chauffés ou réchauffés au four à micro-ondes dans leur coquille ou avec leur jaune intact ; cela pourrait provoquer une accumulation de pression et l'éclatement de l'oeuf. Percer le jaune avec une fourchette ou un couteau avant la cuisson.
4. Percer la peau des pommes de terre, tomates et aliments similaires avant de les cuire au four à micro-ondes. Lorsque la peau est percée, la vapeur peut s'échapper uniformément.
5. Ne pas faire fonctionner l'appareil sans nourriture à l'intérieur.
6. Pour faire du pop-corn, utiliser uniquement du maïs en paquet spécial micro-ondes (indiqué sur l'étiquette). Le temps nécessaire pour faire éclater le maïs varie en fonction de la puissance du four. Ne pas continuer à faire chauffer le maïs une fois qu'il a fini d'éclater, car il peut brûler ou s'enflammer. Ne pas laisser le four sans surveillance.
7. Ne pas utiliser de thermomètre de cuisson pour four traditionnel dans le four. La plupart des thermomètres de cuisson contiennent du mercure qui peut causer des arcs électriques ou le mauvais fonctionnement du four, ou encore endommager celui-ci.
8. Ne pas faire chauffer de biberon au four.
9. Ne pas utiliser d'ustensiles métalliques dans le four.
10. Ne jamais utiliser de papier, de plastique ni autre matériau combustible non prévu pour la cuisson.
11. Si la cuisson utilise du papier, du plastique ou autre matériau combustible, suivre les recommandations du fabricant concernant son utilisation.
12. Ne pas utiliser de serviettes en papier contenant du nylon ou autres fibres synthétiques. Ces fibres pourraient fondre et faire enflammer le papier.
13. Ne pas faire chauffer de récipients ni de sacs en plastique hermétiquement fermés dans le four. La nourriture ou le liquide pourrait gonfler rapidement et faire éclater le récipient ou le sachet. Percer ou ouvrir celui-ci avant de le faire chauffer.
14. Pour éviter toute défaillance de stimulateur cardiaque, prière de se renseigner auprès du médecin ou du fabricant du stimulateur au sujet des effets de l'énergie micro-ondes sur ce dispositif.

PRECAUTIONS CONTRE LES RISQUES D'EXPOSITION À UN EXCES DE MICRO-ONDES

- a. **NE PAS** essayer de faire fonctionner le four avec la porte ouverte car cela peut entraîner une exposition dangereuse aux micro-ondes. Il est important de ne pas modifier les verrouillages de sécurité ni d'entraver leur fonctionnement.
- b. **NE PAS** placer d'objet entre le cadre avant du four et la porte ni laisser de saletés ou de résidus de produit nettoyant s'accumuler sur les surfaces formant joint.
- c. **NE PAS** utiliser le four s'il est endommagé. Il est particulièrement important que sa porte ferme correctement et que les éléments suivants ne soient pas endommagés : (1) porte (faussée), (2) charnières et dispositifs de verrouillage (cassés ou présentant du jeu), (3) joints de la porte et surfaces formant joint.
- d. Ce four ne doit **PAS** être réglé ni réparé par une personne autre qu'un technicien de service après-vente dûment qualifié.

CONSERVER CES INSTRUCTIONS

Mise à la terre

DANGER

Pour éviter tout risque d'électrocution, voire de décès, cet appareil doit être relié à la terre.

DANGER

Pour éviter tout risque d'électrocution, voire de décès, ne pas modifier la fiche.

Cet appareil **DOIT** être relié à la terre. En cas de court-circuit, la mise à la terre réduit les risques d'électrocution en permettant au courant électrique de passer par un fil. Ce four est muni d'un cordon équipé d'un fil de mise à la terre avec une fiche de mise à la terre. La fiche doit être branchée dans une prise correctement installée et mise à la terre.

Consulter un électricien ou un prestataire de service qualifié si les instructions de mise à la terre ne sont pas bien comprises ou si un doute subsiste quant à la mise à la terre correcte de l'équipement.

Ne pas utiliser de rallonge. Si le cordon d'alimentation de l'appareil est trop court, demander à un électricien d'installer une prise de courant à trois trous. Ce four doit être branché sur un circuit indépendant de 60 Hz dont la puissance nominale est indiquée sur l'illustration correspondante. HDC10/HDC12 nécessite une tension d'alimentation de 120V. [HDC18/HDC21](#) nécessite une tension d'alimentation de 208V-230V. Lorsqu'un four à micro-ondes est branché sur un circuit avec d'autres appareils, les temps de cuisson pourront être prolongés et des fusibles pourraient sauter.

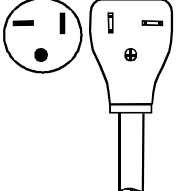
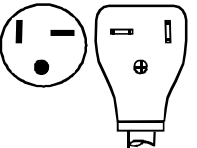
Modèle	NEMA	Réception and Fiche
HDC10 HDC12	NEMA 5-20R/5-20P 120V-20AMP	
HDC18 HDC21	NEMA 6-20R/6-20P 250V-20AMP	

Grounding Instructions

WARNING

To avoid risk of electrical shock or death, this oven must be grounded.

WARNING

To avoid risk of electrical shock or death, do not alter the plug.

This oven **MUST** be grounded. In the event of an electrical short circuit, grounding reduces the risk of electric shock by providing an escape wire for the electric current. This oven is equipped with a cord having a grounding wire with a grounding plug. The plug must be plugged into an outlet that is properly installed and grounded.

Consult a qualified electrician or servicer if grounding instructions are not completely understood, or if doubt exists as to whether the oven is properly grounded.

Do not use an extension cord. If the product power cord is too short, have a qualified electrician install a three-slot receptacle. This oven should be plugged into a separate 60 hertz circuit with the electrical rating as shown in the appropriate drawing. [HDC21](#) and [HDC18](#) require a 208-230 supply voltage. HDC10 and HDC12 require a 120 supply voltage. When a microwave oven is on a circuit with other equipment, an increase in cooking times may be required and fuses can be blown.

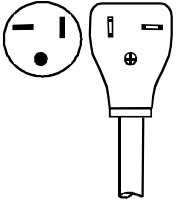
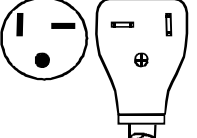
Model	NEMA Designation	Receptacle and Plug
HDC10 HDC12	NEMA 5-20R/5-20P 120V-20AMP	
HDC18 HDC21	NEMA 6-20R/6-20P 250V-20AMP	

Installation

Specifications

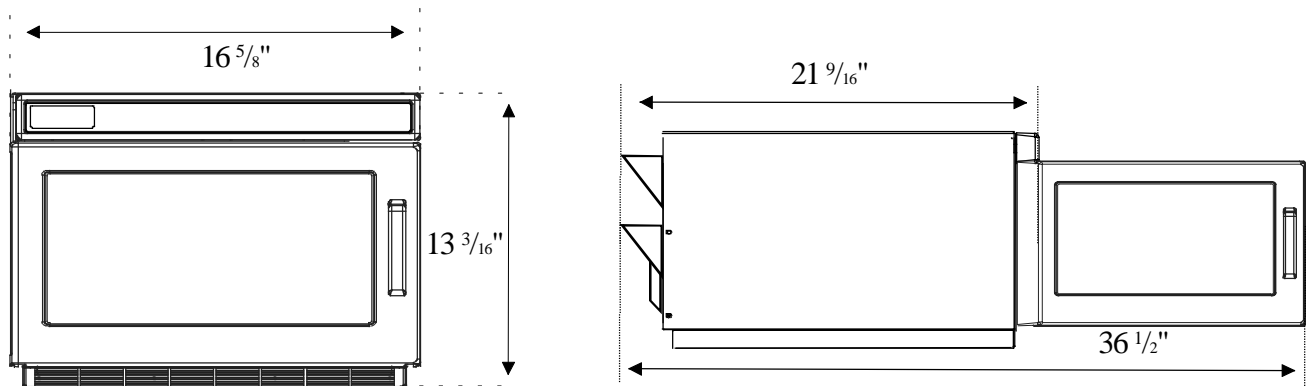

Models	HDC10	HDC12	HDC18	HDC21
Power Source				
Voltage AC	120 VAC	120 VAC	230/208 VAC	230/208 VAC
Amperage (Single Unit)	20 A	20 A	20 A	20 A
Frequency	60 Hz	60 Hz	60 Hz	60 Hz
Single Phase, 3-wire ground	X	X	X	X
Receptacle	5-20R	5-20R	6-20R	6-20R
Plug	5-20P	5-20P	6-20P	6-20P
Power				
Nominal Microwave Energy (IEC705)	1000 Watts	1200 Watts	1800 Watts	2100 Watts
Frequency	2450 MHz	2450 MHz	2450 MHz	2450 MHz
Power Consumption	1800 watts	2300 watts	3000 watts	3200 watts
Dimensions				
Oven Exterior	Width 16 ⁵ / ₈ " x Height 13 ³ / ₁₆ " x Depth 21 ⁹ / ₁₆ "			
Oven Cavity Dimensions	Width 13" x Height 6 ⁷ / ₈ " x Depth 12"			
Net Weight	Crated 74lbs. Uncrated 68lbs.			
Oven Cavity Capacity	0.6 Cu. Ft.			
Power Cord	5' 6"			

Product specifications can change at any time without notice.

Unpacking Oven

- Inspect oven for damage such as dents in door or dents inside oven cavity.
- Report any dents or breakage to source of purchase immediately. Do not attempt to use oven if damaged.
- Remove all materials from oven interior.
- If oven has been stored in extremely cold area, wait a few hours before connecting power.

Radio Interference

Microwave operation may cause interference to radio, television, or similar a oven. Reduce or eliminate interference by doing the following:

- Clean door and sealing surfaces of oven according to instructions in "Care and Cleaning" section.
- Place radio, television, etc. as far as possible from oven.
- Use a properly installed antenna on radio, television, etc. to obtain stronger signal reception.

Oven Placement

- Do not install oven next to or above source of heat, such as pizza oven or deep fat fryer. This could cause microwave oven to operate improperly and could shorten life of electrical parts.
- Do not block or obstruct oven filter. Allow access for cleaning.
- Install oven on level countertop surface.

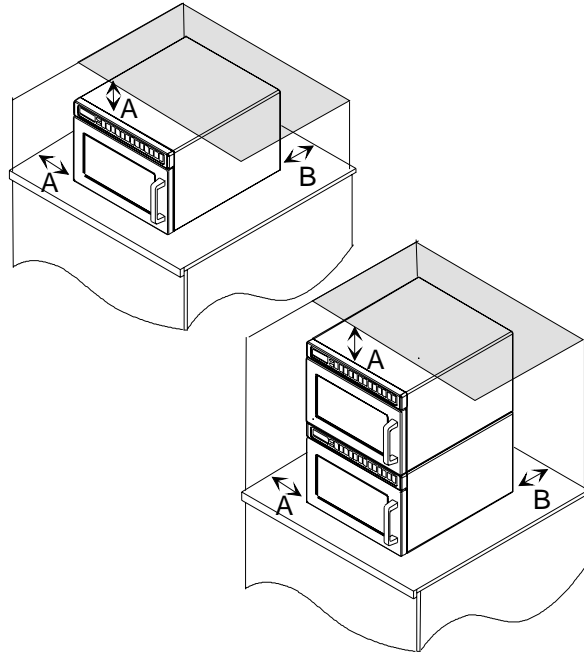

A—Allow at least 7 " (17.8 cm) of clearance around top and sides of oven. Proper air flow around oven cools electrical components. With restricted air flow, oven may not operate properly and life of electrical parts is reduced.

B—Allow at least 2 ⁹/₁₆ " (6.5 cm) between air discharge on back of oven and back wall.

Oven Clearances

Features

Oven Features

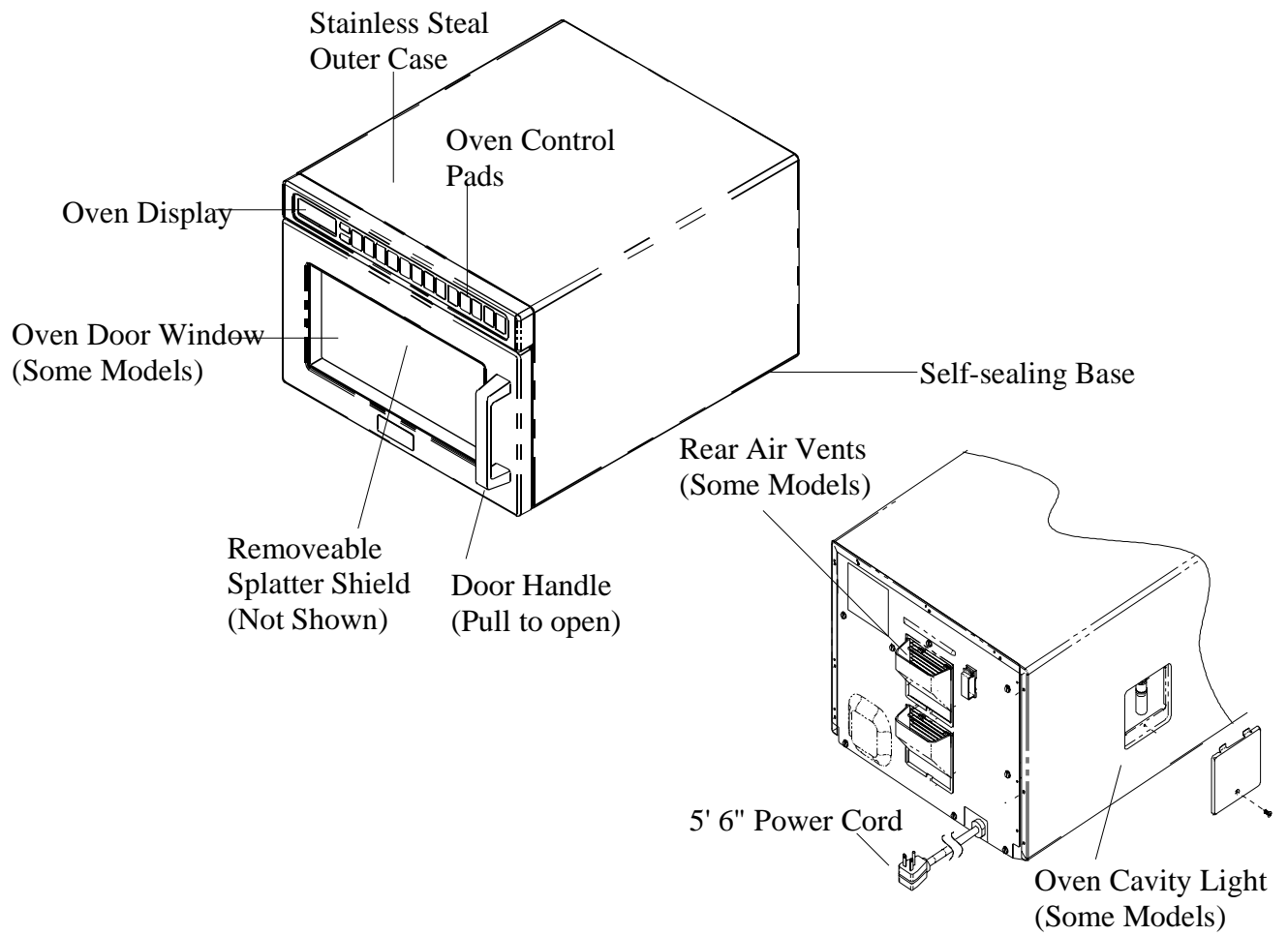

Control Panel Features



TIME ENTRY pad is used to enter cooking time for either manual entry or programming. Cooking time ranges from 1 second (00:01) to a total of 60 minutes (60:00) over four stages. If more than 60 minutes of total microwave cooking time is required, open door and inspect food before beginning new cooking cycle.

x2 pad increases the cooking time when cooking more than one item at a time is necessary. The amount of added time when the X2 pad is pressed is a percent of the original preprogrammed cooking time. The percent can be set from 10% to 100% with the default at 80%. The percent of the time added can be changed for individual cooking sequences.

1 → **0** **Numbered pads** begin cooking programs or enter times and power levels for “Manual Time Entry” cooking.

POWER LEVEL pad is used to set microwave power level. When cooking, the power level can be decreased for foods that require slower more even cooking. Microwave power levels range from 0% to 100% in 10% increments. If cooking time is set and START pad pressed, oven cooks at 100% power. When programming, to reset power level to 100%, press POWER LEVEL pad.

START pad begins Manual Time Entry cooking or restarts an interrupted cooking cycle. When programming, use to save time and power level, and to advance to next user option.

STOP/RESET pad exits programming mode and stop cooking during cooking cycle.

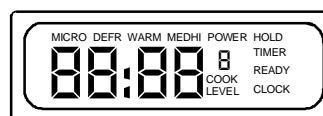

Display
Some items in display can be seen but will not glow.

Stages

This oven can be programmed to run 4 cooking sequences consecutively. Each sequence is called a stage. For example, the first cycle could be programmed to defrost at 60% power, the second to defrost at 30% power, the third to heat at 100% power, and the fourth to hold warm at 10% power. Total time for all cooking stages counts down.

User Options

User Options allow the user to program the oven to perform in a way convenient to the user. The beeps, maximum cooking time, and number of preprogrammed cooking sequences can be changed.

Cooking Methods

MEMORY PADS

This oven can store either 10 or 100 cooking programs in memory.

Single Pad Cooking

From the factory, it is programmed to store 10 cooking programs. Each pad begins a cooking program.



Double Pad Cooking

The oven control can be changed to store up to 100 cooking programs. To set the control to 100 cooking programs, see the "User's Options" section of this manual.



To heat when the oven is set for 100 programs, press 2 memory pads. For example, to start the first program, press pad 0, then pad 1. To use the second program, press pad 0, then pad 2. After the pads are pressed, the oven starts automatically and time counts down.

MANUAL TIME ENTRY

Manual Time Entry feature allows the operator to heat without changing the preprogrammed pads. Time must be entered and power can be set before cooking. START pad must be pressed to begin cooking.

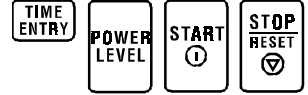

Cooking Displays



READY shows when oven control will accept entries.

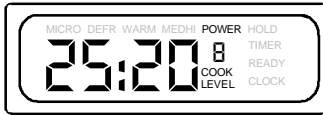

25:20 shows cooking time. When more than one cooking stage is programmed, total time for all stages displays.

POWER Shows when microwave energy is generated. COOK LEVEL shows when oven is operating. 8 indicates the microwave power level used. If number does not show, oven is cooking at 100% power.

Programming Displays



This display indicates oven is in programming mode and ready to program a numbered pad(s).

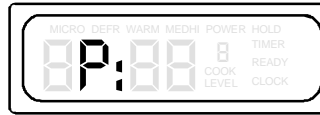

This display indicates oven is set to double pad entry and 2 pads must be pressed to

enter a program. See "Programming" section of manual for programming procedure or "User Options" to change from single or double pad entry.



This display shows briefly when programming more than one stage. It indicates programming mode for pad 02. The smaller "1" indicates stage 1 is being programmed.

smaller "1" indicates stage 1 is being programmed.

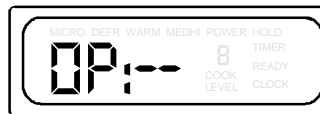

This display indicates programming user options mode. See "User Options" section

of manual for programming procedure.

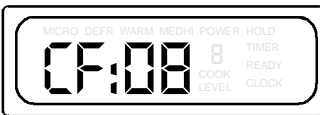

This display indicates cooking factor of 80% when X2 pad is pressed.

Operation

Interrupting Operation

Open oven door or press *STOP/RESET* pad to interrupt operation. Display continues to show countdown time. Close door and press *START* pad to resume oven operation.



Canceling Mistakes

If oven is not cooking, press *STOP/RESET* pad to clear display. If oven is cooking, press *STOP/RESET* pad once to stop oven, then again to clear display. If oven door is open and time shows in display, close oven door and press *STOP/RESET* pad to clear display.



Operating Preprogrammed Pads

From the factory, this oven can store up to 10 preprogrammed cooking sequences in memory. To heat using a preprogrammed sequence, press a numbered pad. Oven starts to heat automatically. Example: Heat using the third cooking sequence.



- Open oven door, place food in oven, and close oven door.
 - Display shows "READY".
 - If pad is not pressed in 60 seconds, open and close oven door again.
- Press 3 pad.
 - Oven operates and time counts down.
 - Display shows cooking time, "POWER", "COOK LEVEL". Display shows "POWER" only when microwave energy is present.
 - If power level other than 100 percent power was programmed, display shows "COOK LEVEL" and power level.
 - If additional cooking time is required, press preprogrammed pads before or after cooking cycle ends.
- Oven stops cooking and oven signal sounds when cooking timing elapses.

Preprogrammed Times and Cook Level

All preprogrammed pads arrive set at full power.

Pads	Times	Pads	Times
1	10 sec.	6	1:30 min.
2	20 sec.	7	2 min.
3	30 sec.	8	3 min.
4	45 sec.	9	4 min.
5	1 min.	0	5 min.

Double Pad Programs

The oven control can be changed to store up to 100 cooking programs. See the "User's Options" section of this manual to change oven control.



To start a double pad cooking program, press 2 memory pads. For example, press pad 0 and pad 3 to start a cooking program.

Using X2 Pad

X2 pad increases the cooking time when cooking more than one item at a time is necessary. The amount of added time when the X2 pad is pressed is a percent of the original preprogrammed cooking time. The percent can be set from 10% to 100% with the default at 80%. The percent of the time added can be changed for individual cooking programs. Press X2 pad before pressing memory pad. For example, press X2 pad and then memory pad 3. Pad 3 normally cooks for 30 seconds. When the X2 pad is pressed before memory pad 3, 54 seconds displays because it added 24 seconds, (80% of 30 sec. =24 sec.).



Manual Time Entry

Manual Time Entry feature allows the operator to enter time and power levels, and heat without changing the preprogrammed pads. Example: Heat for 30 seconds at 80% power.

- Open oven door, place food in oven, and close door.
 - Display shows "READY". Fan and light operate.
 - If pad is not pressed in 60 seconds, open and close oven door again.
- Press TIME ENTRY pad.
 - Display shows "0000" and "READY".
- Press 3 and 0 pad to enter cooking time.
- Press POWER LEVEL pad to change power level.
 - Display shows "COOK LEVEL" and current power level if other than 100 percent power.
- Press 8 pad to enter desired power level.
- Press START pad.
 - Oven operates and time counts down.
 - Display shows cooking time, "POWER", "COOK LEVEL".
 - Display shows "POWER" only when microwave energy is present.
 - If power level other than 100 percent power was programmed, display shows "COOK LEVEL" and power level. Display counts down cooking time.
- Oven stops cooking and oven signal sounds when cooking timing elapses.



Programming

Memory Pads

From the factory, this oven can store up to 10 cooking programs. Follow instructions below to program cooking times and power levels for customized cooking. Example: Program third cooking sequence to heat for 30 seconds at 80% power.

1. Open oven door.
 - Display shows "READY".
 - If door is closed or RESET pad is pressed before finishing programming sequence, oven exits programming mode.
2. Press and hold pad 1 for approximately 5 seconds.
 - After 5 seconds, signal sounds.
 - Display shows "P:0".
3. Press 3 pad to select memory pad.
 - Display shows cooking time, "COOK LEVEL" and power level if other than 100 percent power.
4. Press 3 and 0 pad to enter desired cooking time.
5. Press POWER LEVEL pad to change power level.
 - Display shows "COOK LEVEL" and current power level if other than 100 percent power.
6. Press 8 pad to enter desired power level.
7. Press START pad to save new cooking time and power level in oven memory.
 - Display shows "P:0".
 - Repeat step 3–8 to program additional pads.
8. Press STOP/RESET pad or close oven door to exit programming mode.



Double Pad Programs

The oven control can be changed to store up to 100 cooking programs. See the "User's Options" section of this manual to change oven control.

To create a double pad program, follow the instructions above except for a change to step #3. When entering the cooking program number, press 2 memory pads. For example, press pads 0 and pad 3 to create a new cooking program.



Multiple Cooking Stages

Follow instructions below to program oven to perform four consecutive cooking cycles without interruption. Example: Program third cooking sequence to heat for 30 seconds at 80% power, 40 seconds at 50% power, and 10 seconds at 100% power.

1. Open oven door.
 - Display shows "READY".
 - If door is closed or RESET pad is pressed before finishing programming sequence, oven exits programming mode.
2. Press pad 1 for approximately 5 seconds.
 - After 5 seconds, signal sounds.
 - Display shows "P:0".
4. Press 3 pad to select memory pad.
 - Display shows cooking time, "COOK LEVEL" and power level if other than 100 percent power.
5. Press 3 and 0 to enter desired cooking time.
6. Press POWER LEVEL pad to change power level.
 - Display shows "COOK LEVEL" and current power level if other than 100 percent power.
7. Press 8 pad to enter desired power level.
8. Press TIME ENTRY pad.
 - Display briefly shows "P:03⁽¹⁻⁴⁾" indicating programming, pad 3, stage 2. Then cook time and power level for stage show in display.
 - Repeat steps 5–8 to create additional stages.
9. Press START pad to save new cooking time and power level in oven memory.
10. Press STOP/RESET pad or close oven door to exit programming mode.



X2 Quantity Feature

This feature allows the user to change the amount of time added when the X2 pad and then the programmed pad is pressed. Based on the original time, the X2 pad can add from 10%-100% of additional cooking time. The default is 80%. Example: change cooking factor to 50% for third cooking sequence.

1. Open oven door.
 - If door is closed or *RESET* pad is pressed before finishing programming sequence, oven exits programming mode.
2. Press and hold pad 1 for approximately 5 seconds.
 - After 5 seconds, signal sounds. Display shows "P:--".
3. Press 3 pad to select the cooking program.
4. Press 5 pad to change cooking factor.
 - Display shows "CF:05".
5. Press START pad to save changes.
6. Press STOP/RESET pad or close oven door to exit programming mode.

Double Pad Programs

The oven control can be changed to store up to 100 cooking programs. See the "User's Options" section of this manual to change oven control.

To change the quantity for a double pad program, follow the instructions above except for a change to step #3. When entering the cooking program number, press 2 memory pads. For example, press pads 0 and pad 3 to create a new cooking program. After the program is saved, press pad 0 and pad 3 to start a cooking program.



User Options

Follow the instructions below to customized the microwave oven's operation. End-of-cycle signal, maximum cooking time and other options can be changed to meeting your cooking needs.

Example: Change setting to single digit pad operation.

1. Open oven door.
 - If door is closed or *RESET* pad is pressed before finishing programming sequence, oven exits programming mode.
2. Press and hold pad 2 for approximately 5 seconds.
 - After 5 seconds, signal sounds. Display shows "OP:".
3. Press 9 pad.
 - See table for options.
 - Displays shows "OP:91".
 - "OP" represents optional program mode, first number represents option number and second number represents functions currently selected for option.
4. Press 9 pad repeatedly to change setting.
5. Press START pad to save changes.
 - Repeat steps 3-5 to change additional options.
 - Changes appear after door is closed or STOP/RESET is pressed.
6. Press STOP/RESET pad or close oven door to exit programming mode.



Numbered Pads	Display	Options (Factory Settings in Bold)
1 End of Cycle Beep	OP:10 OP:11 OP:12	3 second continuous beep Continuous beep until door is opened 5 beeps bursts until door is opened
2 Speaker Volume	OP:20 OP:21 OP:22 OP:23	Eliminates beep Sets volume to low Sets volume to medium Sets volume to high
3 Key Beep	OP:30 OP:31	Prevents beep when pad is pressed. Allows beep when pad is pressed.
4 Keyboard Enable Window	OP:40 OP:41 OP:42 OP:43	15 seconds after oven door is opened, keyboard disabled 30 seconds after oven door is opened, keyboard disabled 1 minute after oven door is opened, keyboard disabled 2 minutes after oven door is opened, keyboard disabled
5 Add Time during Heating	OP:50 OP:51	Prevents adding heating time while oven is heating. Allows heating time to be changed while oven is heating when a memory pad is pressed.
6 Reset Door Open	OP:60 OP:61	Allows oven to resume heating time countdown after door is opened during cycle. Cancels heating time count down after door is opened during cycle.
7 Maximum Heating Time	OP:70 OP:71	Allows 60 minutes of heating time. Allows 10 minutes of heating time.
8 Manual Operation	OP:80 OP:81	Allows use of preprogrammed pads only. Allows use of manual time entry and preprogrammed pads.
9 Double Digit Operation	OP:90 OP:91	Allows 10 (0-9) preprogrammed pads. Allows 100 (00-99) preprogrammed pads.

Cooking Guidelines

The Amana Microwave Oven can make your job easier. You'll cook ahead and pre-portion more. You'll also spend less time preparing special-order dishes.

To be sure of consistently good results, you'll want to remember a few simple guidelines.

Food Variables

Microwave cooking can be directly affected by different food variables.

The **shape** of foods can greatly affect the amount of cooking time. Foods that are flat and thin heat faster than foods which are chunky. For example, a casserole will cook faster in a flat dish, rather than if heaped in a small dish. Foods cut into small pieces will cook faster than large-shaped foods. Pieces should be of a uniform size and shape for more uniform cooking, or the smaller pieces will cook faster. The greatest amount of cooking takes place within $\frac{3}{4}$ " of the food's surface. The interior of large food items, or dense foods, is heated by the heat conducted from the outer food layer. The most uniform cooking occurs in flat, doughnut-shaped foods. For best results, cook foods together which have similar sizes and shapes.

The **quantity** or volume of a food can affect the amount of cooking time. As the volume of the food is increased, the time required to cook or heat the item increases almost proportionately. If twice the amount of food is placed in the oven, it will take almost twice as long to cook. To determine the time for larger quantities, multiply the individual serving time by the increased amount, then reduce the total cooking time by about 20%.

The **density** of foods can greatly affect the amount of cooking time. Porous foods, such as breads, cakes or pastries, will heat much more quickly than dense meats of the same size. Porous foods absorb microwaves quickly throughout. Meats absorb microwaves mostly at the exterior surface, and the interior is heated by conduction, increasing the cooking time. Meats can be cooked in a sauce, if desired. Due to the moisture content, a sauce will heat rapidly. The heat will transfer to the meat, so the meat will heat faster due to heat by conduction as well as by microwaves.

The **starting temperature** of foods affects the amount of cooking time. Each temperature degree that the food item is to raise must be supplied with a definite amount of energy. Lower initial starting temperatures require more energy and more time to cook. Therefore, refrigerator temperature foods require a longer cooking time than do room temperature foods. Foods already slightly warm will heat very quickly in the oven.

The **moisture content** of foods affects the amount of cooking time. The higher the moisture content is in a food the longer the amount of cooking time.

The **fat and sugar content** of foods affects the amount of cooking time. Foods containing high fat and sugar levels heat very quickly and may reach much higher temperatures than foods having low fat and sugar levels. Foods having lower fat and sugar levels require longer cooking times.

The **arrangement** of food within a microwave oven cavity affects the way in which the food cooks. A "round" arrangement is best. Use round utensils whenever possible. Also, arrange foods such as baked potatoes in a circle, rather than in rows, for cooking. When only one food item is being cooked, place it in the center of the oven glass shelf for cooking.

Manipulation of Foods

Sometimes recipes suggest manipulating or moving food during cooking. There are several forms of manipulation:

Stirring is required less often in microwave cooking than in conventional cooking. In conventional cooking, you use a spoon to move food up from the bottom of a pan to evenly distribute the heat. In microwave cooking, you still stir to redistribute the heat within some foods, but you need to stir from the outside of a dish toward the inside or center. If a recipe states to stir once or twice during cooking, stir at approximately even intervals. For example, in a 12-minute cooking period, if a recipe states to stir twice, stir after 4 minutes of cooking and again, after 8 minutes of cooking. However, it is not necessary to be precise. Stir only when necessary. When using lower power levels or settings, less stirring is required. Some examples of foods which may require stirring are puddings, some casseroles, some sauces, some soups, and some egg dishes. Some foods can't be stirred. These foods are rearranged or turned.

Some foods can't be stirred and should be **repositioned or rearranged** during cooking. Some examples include baked potatoes, cupcakes (in custard cups), chicken pieces, and others. Rearranging allows for more even cooking of foods. Foods which are cooked, covered, or which are cooked using lower power levels, usually require little rearranging.

There are actually **two types of turning**. Turning is done when foods cannot be stirred. Foods which are cooked, covered, or which are cooked at lower power levels usually require little turning.

Turning foods over: Turning foods over is done to distribute heat. Meat and poultry are two types of foods which are sometimes "turned over." Examples include roasts, turkeys and whole chickens. Small meat items such as poultry pieces may need to be turned over when in casseroles, or when in a browning skillet.

Rotating or turning dishes: There are a few foods which cannot be stirred, rearranged or turned over. Therefore, the actual cooking dish is turned or rotated. A half-turn means to grasp the dish and turn the portion of the dish that faces the oven door around, until it faces the back of the oven. Examples of foods which are sometimes turned or rotated in a cooking dish include cakes, quiches, or soufflés. When cooking foods at lower power levels or Settings, less turning of the cooking dishes is required.

Microwave Utensils

Never use cooking containers or covers with any metal content. This includes all metal and enameled metal-core ware, foil, and metal-trimmed containers. Suitable cooking containers include those made of paper products, glass, china, cloth, and wicker baskets.

Recommended	Not Recommended
Glass/ceramic	Aluminum foil
Natural fiber cloth	Grocery bags
Non-recycled paper	Recycled paper
Plastic	Lead crystal
Wood	Newspapers
	Metal
	Metallic trimmed china

Utensil Check Test

Use the following test to check utensils for microwave safeness.

1. Place glass measuring cup of water next to empty dish to be tested in microwave oven.
2. Heat on full power for one minute.
3. Check temperature of dish and water.
 - If dish remains cool and water is hot, dish is microwave safe.
 - If dish is slightly warm, use for short term cooking.
 - If dish is hot and water is cool, do not use. Dish remains cool if not absorbing microwaves and microwaves are being absorbed by water. Dish becomes hot if absorbing microwaves.

Cooking Hints

Cover foods for faster, more even cooking. Glass lids, plastic wrap, plate covers or other paper products may be used. Do not seal. Instead, allow for steam-venting at all times.

Pierce pouches, plastic wrap covers and all foods with a thin skin or membrane, such as potatoes, squash, tomatoes, eggs, etc. This prevents an eruption in the oven and allows for expansion and/or the escape of steam.

Foods should be carefully plated. For best results, arrange food such as vegetables or casserole-type items evenly around the edge of the plate with slightly less depth in the center. The edges of food items should not overlap or overhang the rim of the container. Cover meats with gravy or au jus and moisten all dry foods other than bread or pastry items.

Do not stack food or plated dishes in your oven.



Instead, when cooking more than one serving or platters, all plates should be placed at the same level in the oven, with space between all containers.

Care and Cleaning

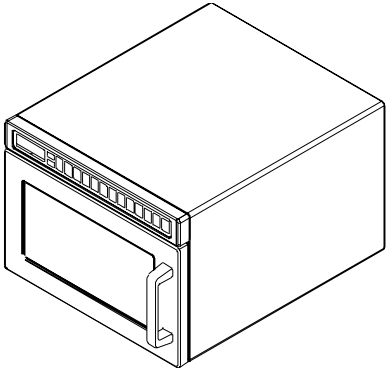
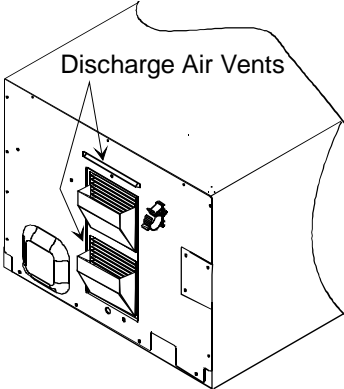

WARNING

To avoid electrical shock which can cause severe personal injury or death, unplug power cord or open circuit breaker to oven before cleaning or removing light bulb.

Part	Description
<p data-bbox="177 459 492 489">Interior, Exterior, and Door</p> 	<p data-bbox="641 462 1468 579">Clean microwave oven with mild detergent in warm water using soft sponge or cloth. Wring sponge or cloth to remove excess water before wiping equipment. If desired, boil a cup of water in microwave oven to loosen soil before cleaning.</p> <p data-bbox="641 646 773 674">Important:</p> <ul data-bbox="641 693 1425 844" style="list-style-type: none"> • Do not use abrasive cleansers or cleaners containing ammonia. These could damage finish. • Never pour water into microwave oven bottom. • Do not use water pressure type cleaning systems.
<p data-bbox="177 953 412 982">Discharge Air Vents</p> 	<p data-bbox="641 953 1511 1045">Check monthly for a buildup of cooking vapors along intake and discharge louvers on bottom and back of oven. Clean air vents with damp cloth to ensure proper airflow. Dry thoroughly.</p>
<p data-bbox="177 1482 339 1512">Control Panel</p> 	<p data-bbox="641 1482 1468 1541">Open oven door to deactivate oven timer. Clean with mild detergent in warm water using soft sponge or cloth.</p>

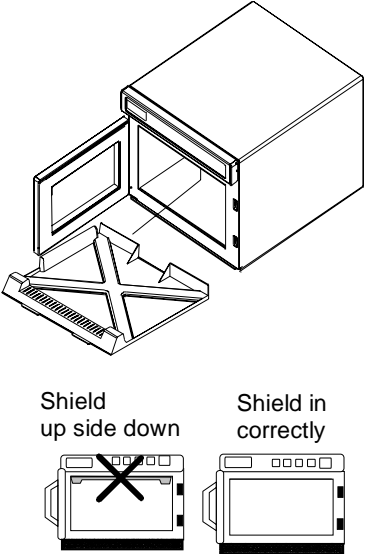
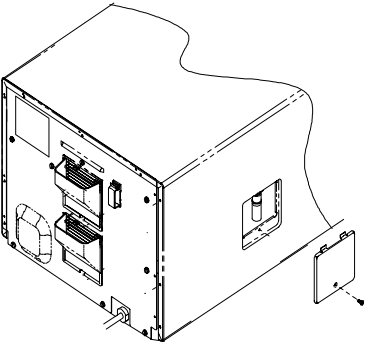
Part	Description
<p data-bbox="110 247 293 275">Air Intake Filter</p>	<p data-bbox="565 247 1419 333">Filter is located below oven door. Clean air intake filter weekly for proper airflow. Wash filter in hot water and mild detergent. Do not use oven without filter in place. Remove filter to clean.</p> <p data-bbox="565 352 691 380">Important</p> <p data-bbox="565 401 1325 428">To avoid overheating and oven damage, clean air filter regularly.</p> <ol data-bbox="565 447 1435 552" style="list-style-type: none"> <li data-bbox="565 447 1435 474">1. Grasp filter tab and pull forward. Filter will release from retaining clips. <li data-bbox="565 493 1386 552">2. To reinstall, place bottom of filter in clips and push top of filter into position.
<p data-bbox="110 573 302 600">Splatter Shields</p>  <p data-bbox="175 999 318 1052">Shield up side down</p> <p data-bbox="370 999 464 1052">Shield in correctly</p>	<p data-bbox="565 573 1435 659">Splatter shield keeps top of microwave oven cavity and antenna from becoming soiled. Clean soil from shield with damp cloth or clean with mild detergent and water. Remove splatter shield for easy cleaning.</p> <p data-bbox="565 678 889 705">Removing Splatter Shield</p> <ol data-bbox="565 724 1435 1136" style="list-style-type: none"> <li data-bbox="565 724 1386 783">1. Unplug oven before removing splatter shield to stop antenna from rotating. <li data-bbox="565 802 1435 1014">2. Place fingers behind shield, pull forward, and down. <ul data-bbox="613 848 1435 1014" style="list-style-type: none"> <li data-bbox="613 848 1435 907">• When removing and replacing splatter shield, be careful not to bend antenna. <li data-bbox="613 926 1435 1014">• If a gap for fingers behind splatter shield does not exist, push up on splatter shield front. Splatter shield may not be installed fully and cannot be removed until splatter shield front is properly installed. <li data-bbox="565 1033 1386 1092">3. Reinstall splatter shield by placing front tabs over lip at top of oven cavity front. Lift back of shield until shield snaps into place. <li data-bbox="565 1110 922 1136">4. Reconnect power to oven.
<p data-bbox="110 1186 423 1213">Changing Oven Light Bulb</p> 	<p data-bbox="586 1207 716 1234">Important</p> <p data-bbox="586 1241 1373 1299">To avoid burns and cuts, wear gloves to protect hands should bulb break. If hot, allow bulb to cool.</p> <p data-bbox="565 1362 743 1390">Tools and Bulb</p> <ul data-bbox="565 1396 1045 1486" style="list-style-type: none"> <li data-bbox="565 1396 792 1423">• Protective gloves <li data-bbox="565 1430 1045 1457">• Standard screwdriver or ¼-inch socket <li data-bbox="565 1463 976 1491">• Light bulb rated 120 volt, 25 watt <ol data-bbox="565 1518 1406 1707" style="list-style-type: none"> <li data-bbox="565 1518 769 1545">1. Unplug oven. <li data-bbox="565 1551 1008 1579">2. Remove screw from side of oven. <li data-bbox="565 1585 1406 1671">3. Remove bulb by turning counterclockwise, being careful not to burn fingers or break bulb. <ul data-bbox="613 1640 1122 1671" style="list-style-type: none"> <li data-bbox="613 1640 1122 1671">• Replace with bulb rated 120 volt, 25 watt. <li data-bbox="565 1680 922 1707">4. Reconnect power to oven.

Before Calling for Service

Record all inspections and repair for future reference.



WARNING

To avoid electrical shock which can cause severe personal injury or death, do not remove outer case at any time. Only an authorized servicer should remove outer case.

Symptom	Check
If oven does not operate:	<ul style="list-style-type: none">• Check fuse or circuit breaker.• Confirm oven is plugged into dedicated circuit.• Confirm oven is on grounded and polarized circuit. Contact electrician to confirm.
If oven light does not work:	<ul style="list-style-type: none">• Confirm light bulb is screwed in tightly.• Confirm light bulb has not failed.
If oven does not accept entries when pad is pressed:	<ul style="list-style-type: none">• Open and close oven door. Press pad again.
If oven malfunctions:	<ul style="list-style-type: none">• Unplug oven, wait for 1 minute, and plug in oven.
If oven operates intermittently:	<ul style="list-style-type: none">• Check air discharge area for obstructions.
Oven operates, but does not heat food:	<ul style="list-style-type: none">• Place one cup cool water in oven. Heat for one minute. If water temperature does not rise, oven is operating incorrectly and a servicer should be called.

Quick Reference Instructions

Read "Important Safety Information" before using "Quick Reference Instructions". If there are unanswered questions, see detailed sections of this manual.

Interrupting Operation

Open oven door or press STOP/RESET pad to interrupt operation. Display continues to show countdown time. Close door and press START pad to resume oven operation.

Canceling Mistakes

If oven is not cooking, press STOP/RESET pad to clear display. If oven is cooking, press STOP/RESET pad once to stop oven, then again to clear display. If oven door is open and time shows in display, close oven door and press STOP/RESET pad to clear display.

Operating Preprogrammed Pads

1. Open oven door, place food in oven, and close oven door.
2. Press numbered pad(s).
3. Oven stops cooking and oven signal sounds when cooking timing elapses.

Manual Time Entry

1. Open oven door, place food in oven, and close door.
2. Press TIME ENTRY pad.
3. Press numbered pads to enter desired cooking time.
4. Press POWER LEVEL pad to change power level.
5. Press a numbered pad to enter desired power level.
6. Press START pad.
7. Oven stops cooking and oven signal sounds when cooking timing elapses.

Programming Number Pads

1. Open oven door.
2. Press and hold pad 1 for approximately 5 seconds.
3. Press numbered pad(s).
4. Press numbered pads to enter desired cooking time.
5. Press POWER LEVEL pad to change power level.
6. Press a numbered pad to enter desired power level.
7. Press START pad to save new cooking time and power level in oven memory.
8. Press STOP/RESET pad or close oven door to exit programming mode.



Programming Multiple Cooking Stages

1. Open oven door.
2. Press pad 1 for approximately 5 seconds.
 - After 5 seconds, signal sounds. Display shows "P".
4. Press numbered pad(s) to select memory pad program.
 - Display shows cooking time, "COOK LEVEL" and power level if other than 100 percent power.
5. Press numbered pads enter desired cooking time.
6. Press POWER LEVEL pad to change power level.
 - Display shows "COOK LEVEL" and current power level if other than 100 percent power.
7. Press numbered pad to enter desired power level.
8. Press TIME ENTRY pad.
 - Display briefly shows "P3⁽¹⁻⁴⁾" indicating programming, pad 3, stage 2. Then cook time and power level for stage show in display.
 - Repeat steps 5-8 to create additional stages.
9. Press START pad to save new cooking time and power level in oven memory.
10. Press STOP/RESET pad or close oven door to exit programming mode.

Changing X2 Quantity Feature

1. Open oven door.
2. Press and hold pad 1 for approximately 5 seconds.
3. Press numbered pad(s) to select cooking sequence.
4. Press numbered pad to change cooking factor.
5. Press START pad to save changes.
6. Press RESET pad or close oven door to exit programming mode.



User Options

1. Open oven door.
2. Press and hold pad 2 for approximately 5 seconds.
3. Press a numbered pad.
4. Press numbered pad repeatedly to change setting.
5. Press START pad to save changes.
6. Press RESET pad or close oven door to exit programming mode.

