

MENUMASTER[®]
Commercial

Service Training Manual

Compact Models



DEC - 50 Hz
CHDC - 50Hz (Chinese Oven)
September 2011
16400016

ACP
INC.[™]
New
HIGH PERFORMANCE HAS A NAME™

Table of Contents

Important Safety Information.....	2-5
Specifications.....	7
Installation.....	7
Quick Start Reference Guide.....	9-10
Components.....	12-16
Disassembly.....	18-19
Capacitor / Diode Location S/N 0902100848 Prior and After.....	21
Capacitor / Diode Location S/N 1103100152 and Earlier.....	22
Capacitor / Diode Location S/N 1103100153 and After.....	23
Airflow.....	25
Component Testing Procedures.....	27-31
Troubleshooting.....	33-35
Wiring and Schematic Diagrams.....	37-44

1 | Important Safety Information

Important Information

Important Notices for Servicers and Consumers

ACP will not be responsible for personal injury or property damage from improper service procedures. Pride and workmanship go into every product to provide our customers with quality products. It is possible, however, that during its lifetime a product may require service. Products should be serviced only by a qualified service technician who is familiar with the safety procedures required in the repair and who is equipped with the proper tools, parts, testing instruments and the appropriate service information. IT IS THE TECHNICIANS RESPONSIBILITY TO REVIEW ALL APPROPRIATE SERVICE INFORMATION BEFORE BEGINNING REPAIRS.

 WARNING
To avoid risk of severe personal injury or death, disconnect power before working/servicing on appliance to avoid electrical shock.

To locate an authorized servicer please contact:

ComServ Support Center



Web Site
WWW.ACPSOLUTIONS.COM

Telephone Number
..... 1-866-426-2621 or 319-368-8195

E-Mail: commercialservice@acpsolutions.com

Recognize Safety Symbols, Words, and Labels

 DANGER

DANGER— Immediate hazards which WILL result in severe personal injury or death.

 WARNING
--

WARNING— Hazards or unsafe practices which COULD result in severe personal injury or death.

 CAUTION
--

CAUTION— Hazards or unsafe practices which COULD result in minor personal injury, product or property damage.

Important Safety Information



WARNING

Read the following information to avoid possible exposure to microwave radiation:

The basic design of the Microwave Oven makes it an inherently safe device to both use and service.

However, there are some precautions which should be followed when servicing the microwave to maintain this safety. These are as follows:

1. Always operate the unit from an adequately grounded outlet. Do not operate on a two-wire extension cord.
2. Before servicing the unit (if unit is operable) perform the microwave leakage test.
3. The oven should never be operated if the door does not fit properly against the seal, the hinges or hinge bearings are damaged or broken; the choke is damaged, (pieces missing, etc.); or any other visible damage can be noted. Check the choke area to ensure that this area is clean and free of all foreign matter.
4. If the oven operates with the door open and produces microwave energy, take the following steps:
 - A. Tell the user not to operate the oven.
 - B. Contact ACP ComServ immediately.
5. Always have the oven disconnected when the outer case is removed except when making the "live" tests called for in the Service Manual. Do not reach into the equipment area while the unit is energized. Make all connections for the test and check them for tightness before plugging the cord into the outlet.
6. Always ground the capacitors on the magnetron filter box with an insulated-handle screwdriver before working in the high voltage area of the equipment compartment. Some types of failures will leave a charge in these capacitors and the discharge could cause a reflex action which could make you injure yourself.
7. Always remember that in the area of the transformer there is HIGH VOLTAGE. When the unit is operating keep this area clear and free of anything which could possibly cause an arc or ground, etc.
8. Do not for any reason defeat the interlock switches there is not valid reason for this action at any time; nor will it be condoned by ACP.
9. IMPORTANT: Before returning a unit to a customer, be sure to check for proper switch interlock action.
10. The Microwave Oven should never be operated with any components removed and/or bypassed or when any of the safety interlocks are found to be defective, or when any of the seal surfaces are defective, missing, or damaged.
11. All microwave ovens meet all requirements of the radiation control for Health and Safety Act of 1968. Due to measurement uncertainties, the maximum leakage for the field will be $4\text{mw}/\text{cm}^2$.
12. To ensure that the unit does not emit excessive microwave leakage and to meet the Department of Health and Human Services guidelines, check the oven for microwave leakage using a microwave oven leakage meter that complies with US Government CDRH / FDA / DHHS requirements and or any other local government requirements. The maximum leakage level allowed by ACP is $4\text{mw}/\text{cm}^2$.
13. If servicer encounters an emission reading over $4\text{mw}/\text{cm}^2$, the servicer is to cease repair and contact the ACP ComServ Department immediately for further direction. ACP will contact the proper Government Agency upon verification of the test results.

IMPORTANT SAFETY INSTRUCTIONS



Recognize this symbol as a **SAFETY** message



WARNING

When using electrical equipment, basic safety precautions should be followed to reduce the risk of burns, electrical shock, fire, or injury to persons including the following.

1. READ all instructions before using equipment.
2. READ AND FOLLOW the specific "PRECAUTIONS TO AVOID POSSIBLE EXPOSURE TO EXCESSIVE MICROWAVE ENERGY" on this page.
3. This equipment **MUST BE GROUNDED**. Connect only to properly GROUNDED outlet. See "GROUNDING / EARTHING INSTRUCTIONS" on page 5.
4. Install or locate this equipment **ONLY** in accordance with the installation instructions in this manual.
5. Some products such as whole eggs and sealed containers—for example, closed glass jars—are able to explode and **SHOULD NOT** be HEATED in this oven.
6. Use this equipment **ONLY** for its intended use as described in this manual. Do not use corrosive chemicals or vapors in this equipment. This type of oven is specifically designed to heat, cook, or dry food. It is not designed for industrial or laboratory use.
7. As with any equipment, **CLOSE SUPERVISION** is necessary when used by **CHILDREN**.
8. See door cleaning instructions on page A-4 of this owners manual.
9. **DO NOT** heat baby bottles in oven.
10. Baby food jars shall be open when heated and contents stirred or shaken before consumption, in order to avoid burns.
11. **DO NOT** operate this equipment if it has a damaged cord or plug, if it is not working properly, or if it has been damaged or dropped.
12. This equipment, including power cord, must be serviced **ONLY** by qualified service personnel. Special tools are required to service equipment. Contact nearest authorized service facility for examination, repair, or adjustment.
13. **DO NOT** cover or block louvers or other openings on equipment.
14. **DO NOT** store this equipment outdoors. **DO NOT** use this product near water – for example, near a kitchen sink, in a wet basement, a swimming pool, or a similar location.
15. **DO NOT** immerse cord or plug in water.
16. Keep cord **AWAY** from **HEATED** surfaces.
17. **DO NOT** let cord hang over edge of table or counter.
18. For commercial use only.

PRECAUTIONS TO AVOID POSSIBLE EXPOSURE TO EXCESSIVE MICROWAVE ENERGY

- A. **DO NOT** attempt to operate this oven with the door open since open door operation can result in harmful exposure to microwave energy. It is important not to defeat or tamper with the safety interlocks.
- B. **DO NOT** place any object between the oven front face and the door too allow soil or cleaner residue to accumulate on sealing surfaces.
- C. **DO NOT** operate the oven if it is damaged. It is particularly important that the oven door close properly and that there is no damage to the:
 1. door (bent)
 2. hinges and latches (broken or loosened)
 3. door seals and sealing surfaces.
- D. The oven should not be adjusted or repaired by anyone except properly qualified service personnel.

SAVE THESE INSTRUCTIONS

IMPORTANT SAFETY INSTRUCTIONS



WARNING

To avoid risk of fire in the oven cavity:

- a. DO NOT overcook food. Carefully attend oven when paper, plastic, or other combustible materials are placed inside the oven to facilitate cooking.
- b. Remove wire twist-ties from paper or plastic bags before placing bag in oven.
- c. If materials inside the oven ignite, keep oven door CLOSED, turn oven off and disconnect the power cord, or shut off power at the fuse or circuit breaker panel.
- d. DO NOT use the cavity for storage. DO NOT leave paper products, cooking utensils, or food in the cavity when not in use.



WARNING

Liquids such as water, coffee, or tea are able to be overheated beyond the boiling point without appearing to be boiling due to surface tension of the liquid. Visible bubbling or boiling when the container is removed from the microwave oven is not always present. THIS COULD RESULT IN VERY HOT LIQUIDS SUDDENLY BOILING OVER WHEN A SPOON OR OTHER UTENSIL IS INSERTED INTO THE LIQUID. To reduce the risk of injury to persons:

- i) Do not overheat the liquid.
- ii) Stir the liquid both before and halfway through heating it.
- iii) Do not use straight-sided containers with narrow necks.
- iv) After heating, allow the container to stand in the microwave oven for a short time before removing the container.
- v) Use extreme care when inserting a spoon or other utensil into the container.



CAUTION

To avoid personal injury or property damage, observe the following:

1. Do not deep fat fry in oven. Fat could overheat and be hazardous to handle.
2. Do not cook or reheat eggs in shell or with an unbroken yolk using microwave energy. Pressure may build up and erupt. Pierce yolk with fork or knife before cooking.
3. Pierce skin of potatoes, tomatoes, and similar foods before cooking with microwave energy. When skin is pierced, steam escapes evenly.
4. Do not operate equipment without load or food in oven cavity.
5. Microwave popcorn should not be popped in oven.
6. Do not use regular cooking thermometers in oven. Most cooking thermometers contain mercury and may cause an electrical arc, malfunction, or damage to oven.
7. Do not use metal utensils in oven.
8. Do not use aluminum foil in oven.
9. Never use paper, plastic, or other combustible materials that are not intended for cooking.
10. When cooking with paper, plastic, or other combustible materials, follow manufacturer's recommendations on product use.
11. Do not use paper towels which contain nylon or other synthetic fibers. Heated synthetics could melt and cause paper to ignite.
12. Do not heat sealed containers or plastic bags in oven. Food or liquid could expand quickly and cause container or bag to break. Pierce or open container or bag before heating.
13. To avoid pacemaker malfunction, consult physician or pacemaker manufacturer about effects of microwave energy on pacemaker.
14. An authorized servicer MUST inspect equipment annually. Record all inspections and repairs for future use.

SAVE THESE INSTRUCTIONS

2

DEC 50 Hz Specifications

Power Specification

- Input
- Output
- Consumption

Oven Dimensions

- Weight

Installation

- Unpacking the oven
- Radio Interference

Specifications

Models	DEC11E2	DEC14E2 CHDC5142	DEC18E2 CHDC5182	DEC21E2 CHDC5212
Power Source				
Voltage AC	230V	230V	230V	230V
Amperage	16 A	16 A	16 A	16 A
Frequency	50 Hz	50 Hz	50 Hz	50 Hz
Single Phase, 3 wire grounded	X	X	X	X
Plug Configuration / Cord	CEE 7/7	CEE 7/7 CHINA	CEE 7/7 CHINA	CEE 7/7
Power Output				
Nominal microwave energy (IEC705)	1100 W	1400 W	1800 W	2100 W
Minimum temperature rise	5.5°C / 11°F	7.5°C / 14°F	10°C / 18°F	11.5°C / 21°F
Operating Frequency	2450 MHz	2450 MHz	2450 MHz	2450 MHz
Power Consumption				
Cook Condition Microwave	2000 W	2300 W	2900 W	3100 W
Dimensions				
Cabinet				
Width	419 (16 ½")	419 (16 ½")	419 (16 ½")	419 (16 ½")
Height	343 (13½")	343 (13½")	343 (13½")	343 (13½")
Depth	549 (21 ⅝")	549 (21 ⅝")	549 (21 ⅝")	549 (21 ⅝")
Cavity Dimensions				
Width	330 (13")	330 (13")	330 (13")	330 (13")
Height	171 (6 ¾")	171 (6 ¾")	171 (6 ¾")	171 (6 ¾")
Depth	305 (12")	305 (12")	305 (12")	305 (12")
Weight				
Crated	28 kg. (62 lbs.)	33 kg. (73 lbs.)	34 kg. (74 lbs.)	34 kg. (74 lbs.)
Uncrated	25 kg. (56 lbs.)	30 kg. (67 lbs.)	31 kg. (68 lbs.)	31 kg. (68 lbs.)

Installation

Unpacking Oven

- Inspect oven for damage such as dents in door or dents inside oven cavity.
- Report any dents or breakage to source of purchase immediately. Do not attempt to use oven if damaged.
- Remove all materials from oven interior.
- If oven has been stored in extremely cold area, wait a few hours before connecting power.

- Place radio, television, etc. as far as possible from oven.
- Use a properly installed antenna on radio, television, etc. to obtain stronger signal reception.

Radio Interference

Microwave operation may cause interference to radio, television, or similar a oven. Reduce or eliminate interference by doing the following:

- Clean door and sealing surfaces of oven according to instructions in "Care and Cleaning" section.

3

DEC 50 Hz Quick Start Reference Guide

Control Panel

- Programming items

Clean Filter

- Settings

User Options

- Changing options
- Factory presets

Quick Start Reference Guide

Refer to Product Safety Manual for Safety Statements
 Complete Owner's Manual available online

CLEAN FILTER

This oven displays CLEAN FILTER at user defined intervals. When the message displays ACP recommends cleaning the air filter thoroughly.

Cleaning the air filter will not shut off the message. The message will stop displaying automatically after 24 hours. Depending on microwave use and environmental conditions, the filter may need to be cleaned more frequently. Once the frequency is determined, set the option for the appropriate time frame.

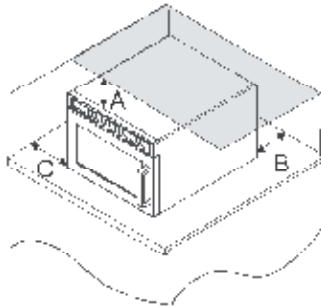

Oven Clearances

A—For North American (UL/CSA) models, allow at least 7" (17.8 cm) of clearance around top of oven. For International (50 Hz) models, allow at least 7" (17.8 cm) of clearance around top of oven. Proper air flow around oven cools electrical components. With restricted air flow, oven may not operate properly and life of electrical parts is reduced.

B—Allow at least 2 9/16" (6.5 cm) between air discharge on back of oven and back wall.

C—Allow at least 7" (17.8 cm) around sides of oven.

So...how do I use it?

1 Preprogrammed Pads

To cook food using preprogrammed cooking sequences.

1. Open oven door and place food in oven. Close door.
2. Press desired pad.
3. Oven begins to cook.
4. At end of cooking cycle oven beeps and shuts off.

x2 X2 Programming (some models)

To change the cooking factor:

1. Open oven door.
2. Press and hold pad 1 for approximately 5 seconds.
3. Press pad to be reprogrammed.
4. Press the X2 pad.
5. Press a numbered pad to change the cooking factor.
 - Cooking factor can be set from 10% to 100%.
 - Default is 80%.
 - Pad 5 would change the cooking factor to 50%.
6. Press START pad to save changes.



Manual Operation

To cook food using a specific entered time and power level.

1. Open oven door and place food in oven. Close door.
2. Press TIME ENTRY pad and enter cooking time.
3. Press POWER LEVEL pad to program level of microwave power if desired.
 - For a lower microwave power, press pads 1 (for 10%), through 9 (for 90%), or 0 for no microwave energy.

NOTE: Press POWER LEVEL pad once to return to 100% microwave power.

4. Press START pad.
5. At end of cooking cycle oven beeps and shuts off.

Programming Items

1. Open oven door.
2. Press and hold pad 1 for approximately 5 seconds.
3. Press pad to be reprogrammed.
4. Enter cooking time by using the number pads.
5. Press POWER LEVEL pad to program level of microwave power if desired.
 - For a lower microwave power, press pads 1 (for 10%), through 9 (for 90%), or 0 for no microwave energy.

NOTE: Press POWER LEVEL pad once to return to 100% microwave power.

6. Press TIME ENTRY pad to add up to four additional cooking stages.
 - Total cooking time cannot exceed 60 minutes.
 - Enter cook time and power level as in steps 4 and 5.

7. Press START pad to set new programming changes to the pad.

NOTE: To discard changes, press STOP/RESET pad or close oven door.

X2 Pad (some models)

1. Open oven door and place food in oven. Close door.
2. Press X2 pad.
3. Press desired preprogrammed pad or pad sequence.
4. Oven begins cooking. Displayed cooking time is the total of original cooking time and added X2 time.

The switching operation of this microwave oven can cause voltage fluctuations on the supply line. The operation of this oven under unfavorable voltage supply conditions can have adverse effects. This device is intended for the connection to a power supply system with a maximum permissible system impedance Z_{max} of **0.31 Ohms** at the interface point of the user's supply. The user has to ensure that this device is connected only to a power supply system which fulfills the requirement above. If necessary, the user can ask the public power supply company for the system impedance at the interface point.

Quick Start Reference Guide

Refer to Product Safety Manual for Safety Statements

Complete Owner's Manual available online

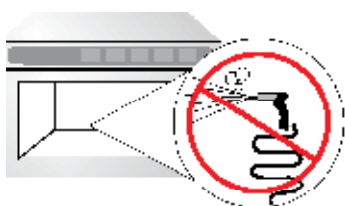

DO NOT power spray

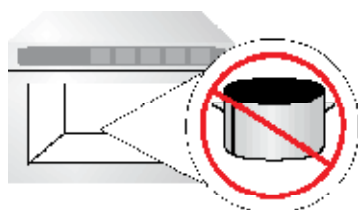



No metal pans

Can I change an option?

Options such as single or double pad programming, beep volume, and maximum cooking time can be changed to suit individual preferences.

To change options:

1. Open oven door.
 - If door is closed or STOP/RESET  pad is pressed before programming is complete, changes are discarded and microwave exits programming mode.
2. Press and hold pad 2 for approximately 5 seconds.
 - This begins options mode.
 - Microwave will beep and **OPTIONS:** displays.
3. Press number pad that controls option to be changed.
 - See table below for options.
 - Current option will display.
4. Press number pad again to change the option.
 - Each time pad is pressed, option will change.
 - Match code displayed with code for desired option.
5. Press START  pad to save changes.
 - To change additional options, repeat steps 3 and 4.
 - Changes appear after door is closed or STOP/RESET  pad is pressed.

Numbered Pads	Display	Options (Factory Settings in Bold)
1 End of Cycle Beep	OP:10	3 second continuous beep.
	OP:11	Continuous beep until door is opened.
	OP:12	5 beeps bursts until door is opened.
2 Speaker Volume	OP:20	Eliminates beep.
	OP:21	Sets volume to low.
	OP:22	Sets volume to medium.
	OP:23	Sets volume to high.
3 Key Beep	OP:30	Prevents beep when pad is pressed.
	OP:31	Allows beep when pad is pressed.
4 Keyboard Enable Window	OP:40	15 seconds after oven door is opened, keyboard disabled.
	OP:41	30 seconds after oven door is opened, keyboard disabled.
	OP:42	1 minute after oven door is opened, keyboard disabled.
5 Add Time During Heating	OP:50	Prevents adding heating time while oven is heating.
	OP:51	Allows heating time to be changed while oven is heating when a memory pad is pressed.
6 Reset Door Open	OP:60	Allows oven to resume heating time countdown after door is opened during cycle.
	OP:61	Cancels heating time count down after door is opened during cycle.
7 Maximum Heating Time	OP:70	Allows 60 minutes of heating time.
	OP:71	Allows 10 minutes of heating time.
8 Manual Operation	OP:80	Allows use of preprogrammed pads only.
	OP:81	Allows use of manual time entry and preprogrammed pads.
9 Double Digit Operation	OP:90	Allows 10 (0-9) preprogrammed pads.
	OP:91	Allows 100 (00-99) preprogrammed pads.
0 Clean Filter Message	OP:00	Do not display message.
	OP:01	Display message for 24 hours every 7 days.
	OP:02	Display message for 24 hours every 30 days.
	OP:03	Display message for 24 hours every 90 days.

4 | DEC 50 Hz Components

Components

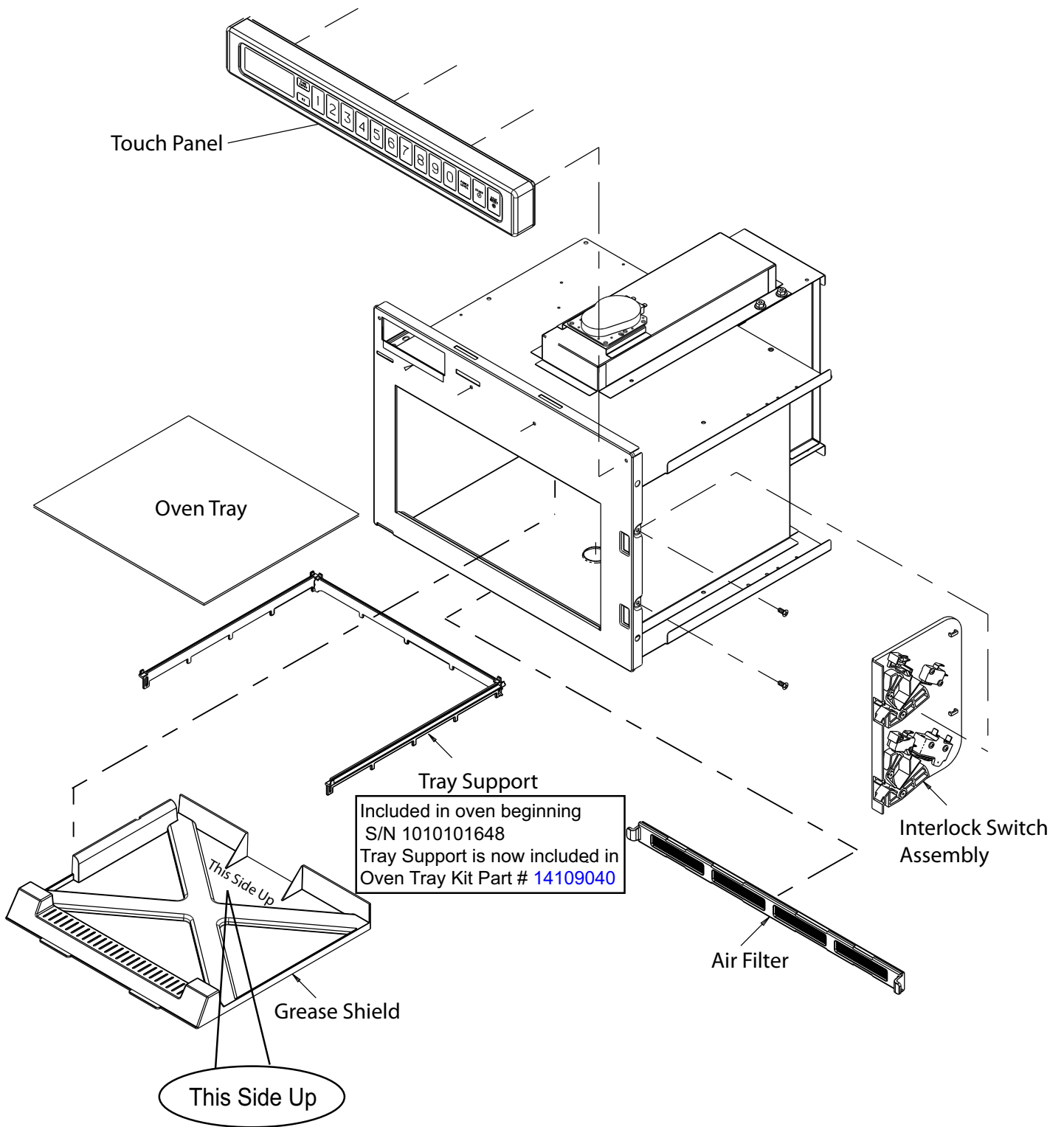

Components

Component location beginning S/N 1103100153

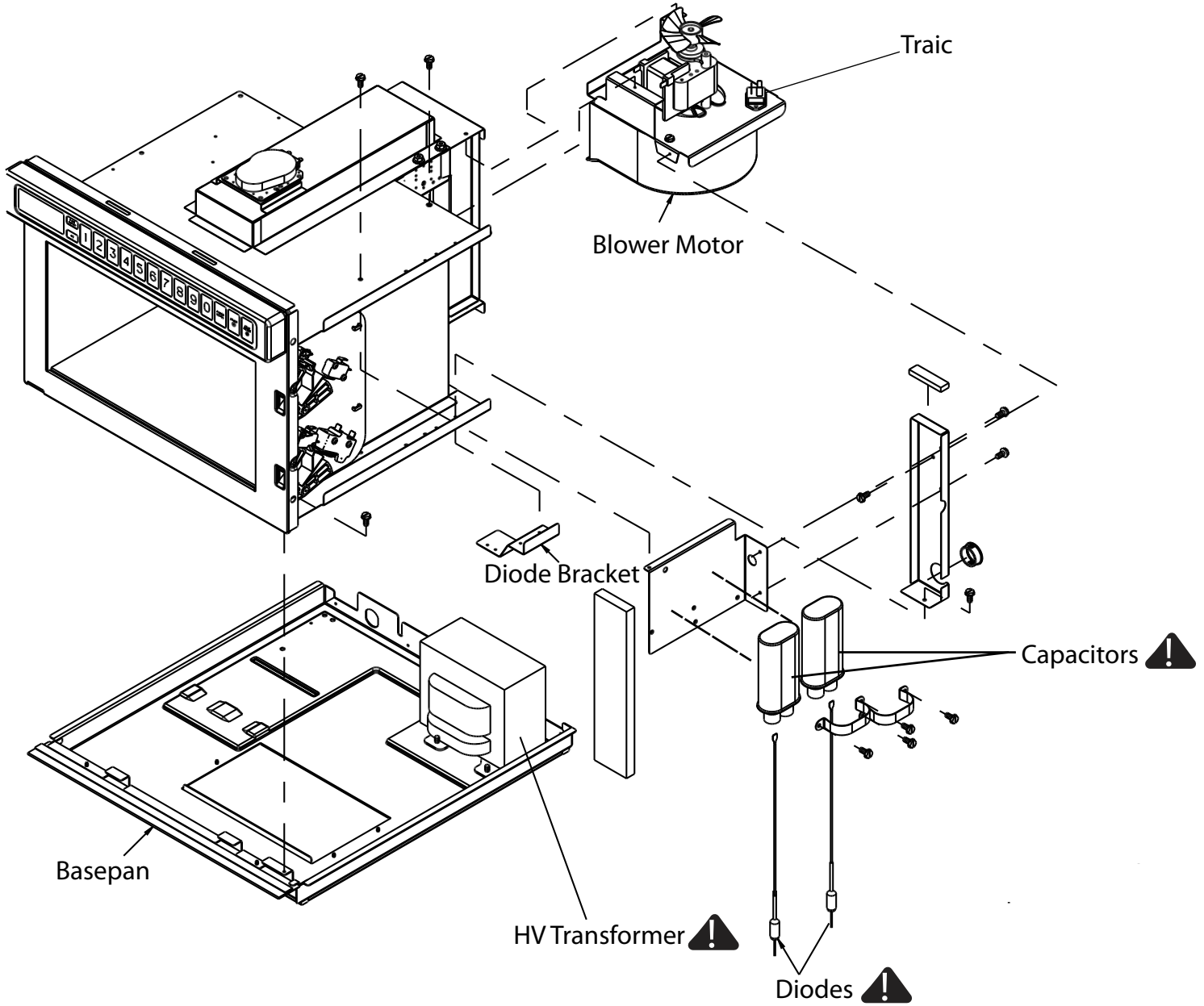

 **DANGER**
High Voltage Components

Components

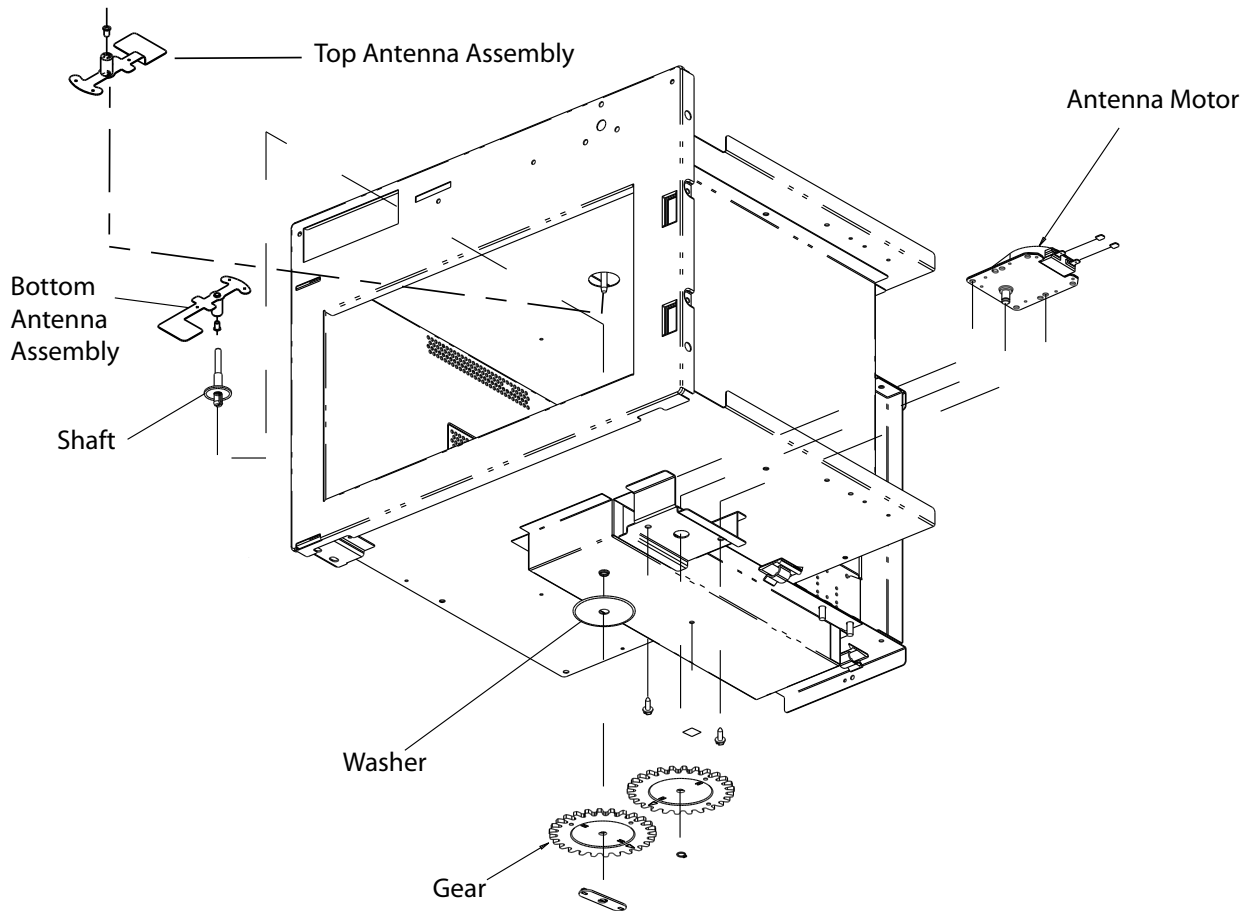
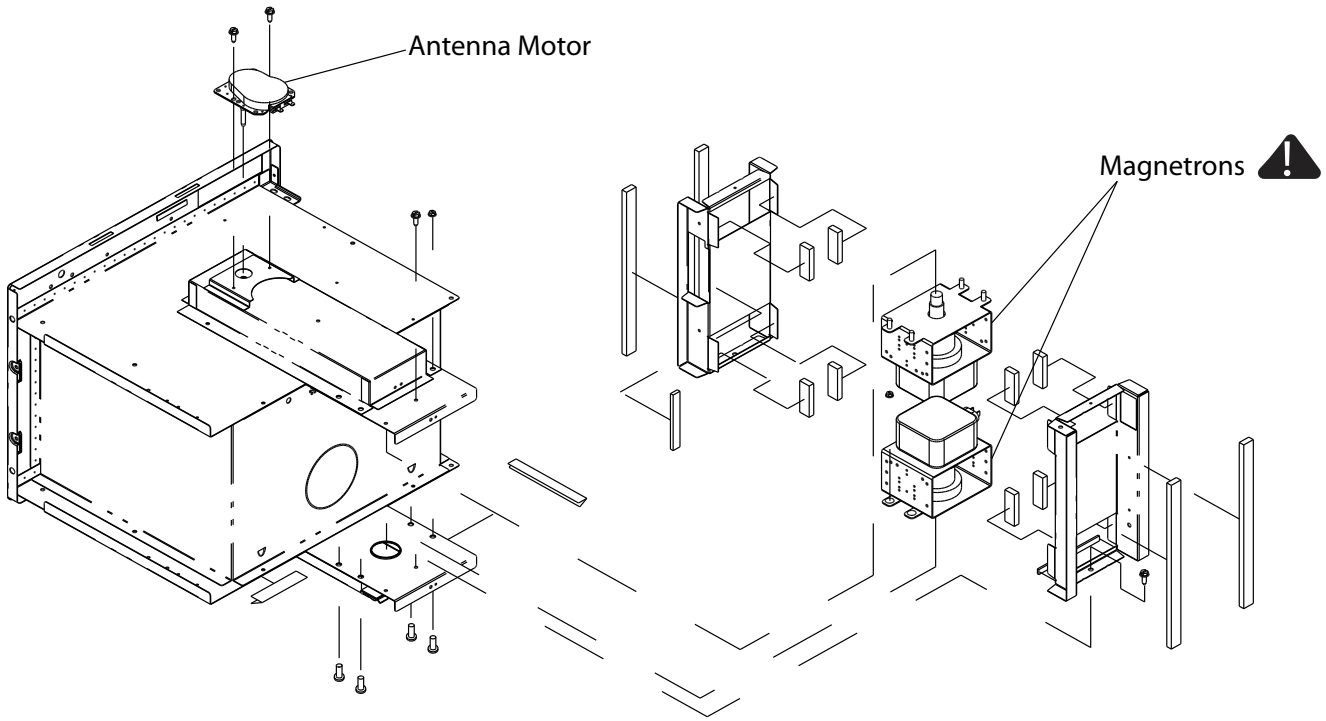

 **DANGER**
High Voltage Components

Components

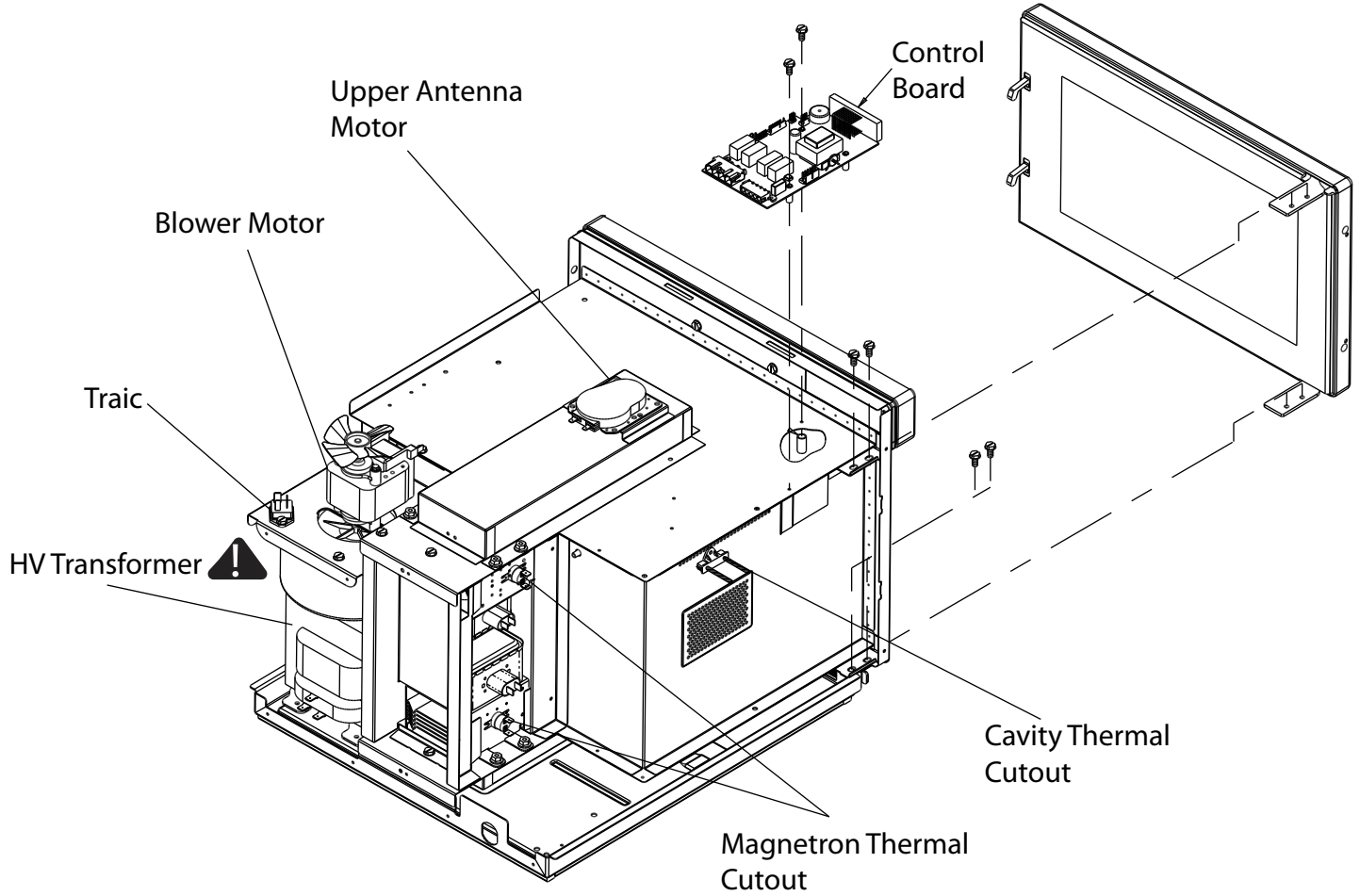

 **DANGER**
High Voltage Components

Components

Sample Door Assembly

Door comes in two styles, see through door and solid door.

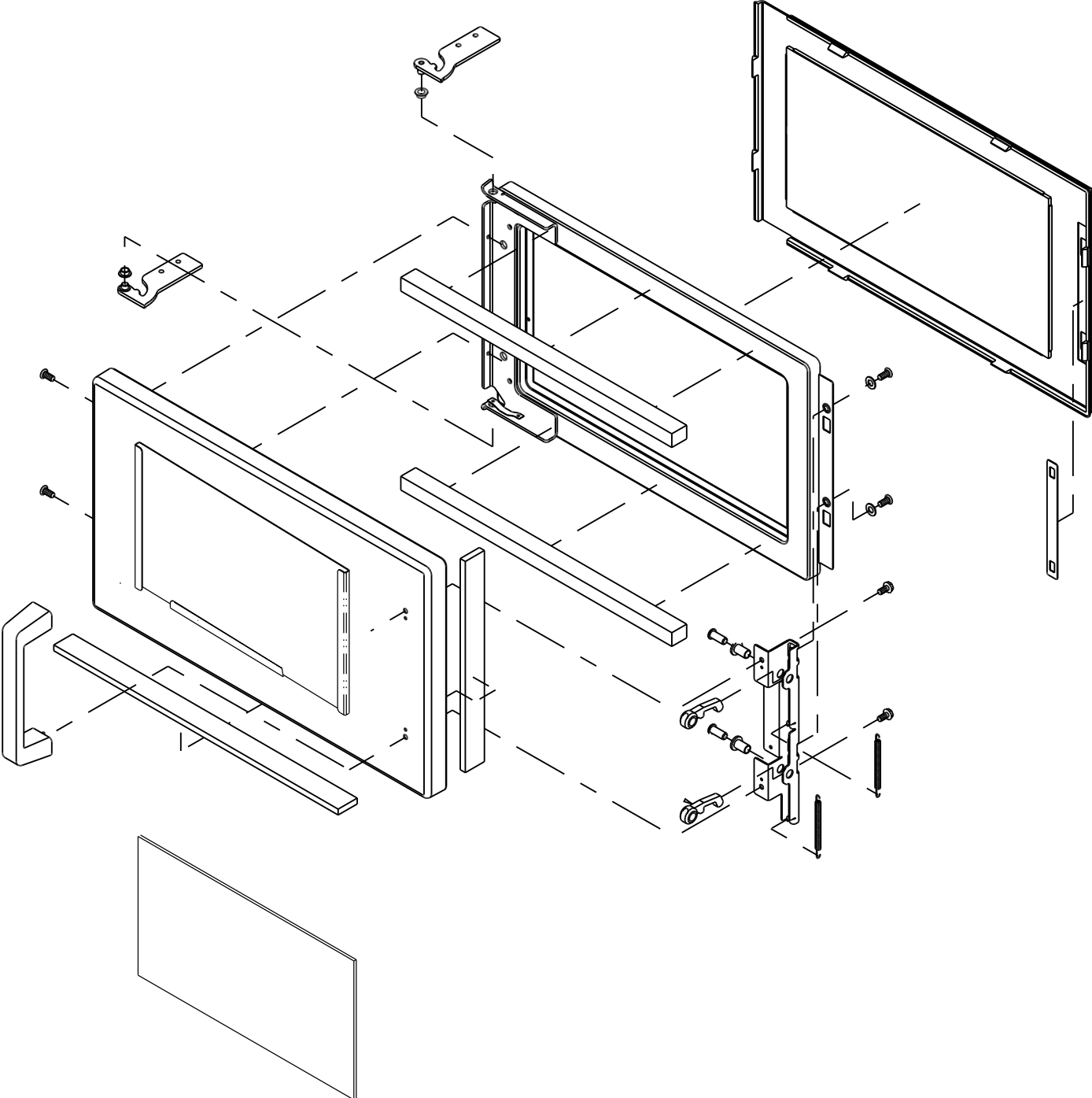

5

Disassembly

Inner door/window removal

Switch replacement/door adjustment

Disassembly

Inner Door/Window Removal

1. Open oven door.
2. Remove screws on hinge side.
3. Beginning at the bottom, carefully insert 1" (25 mm) putty knife between inner and outer door. Pry up on inner door to release tabs, (2 tabs per side). Work in a clockwise direction to release all tabs, see illustration below.

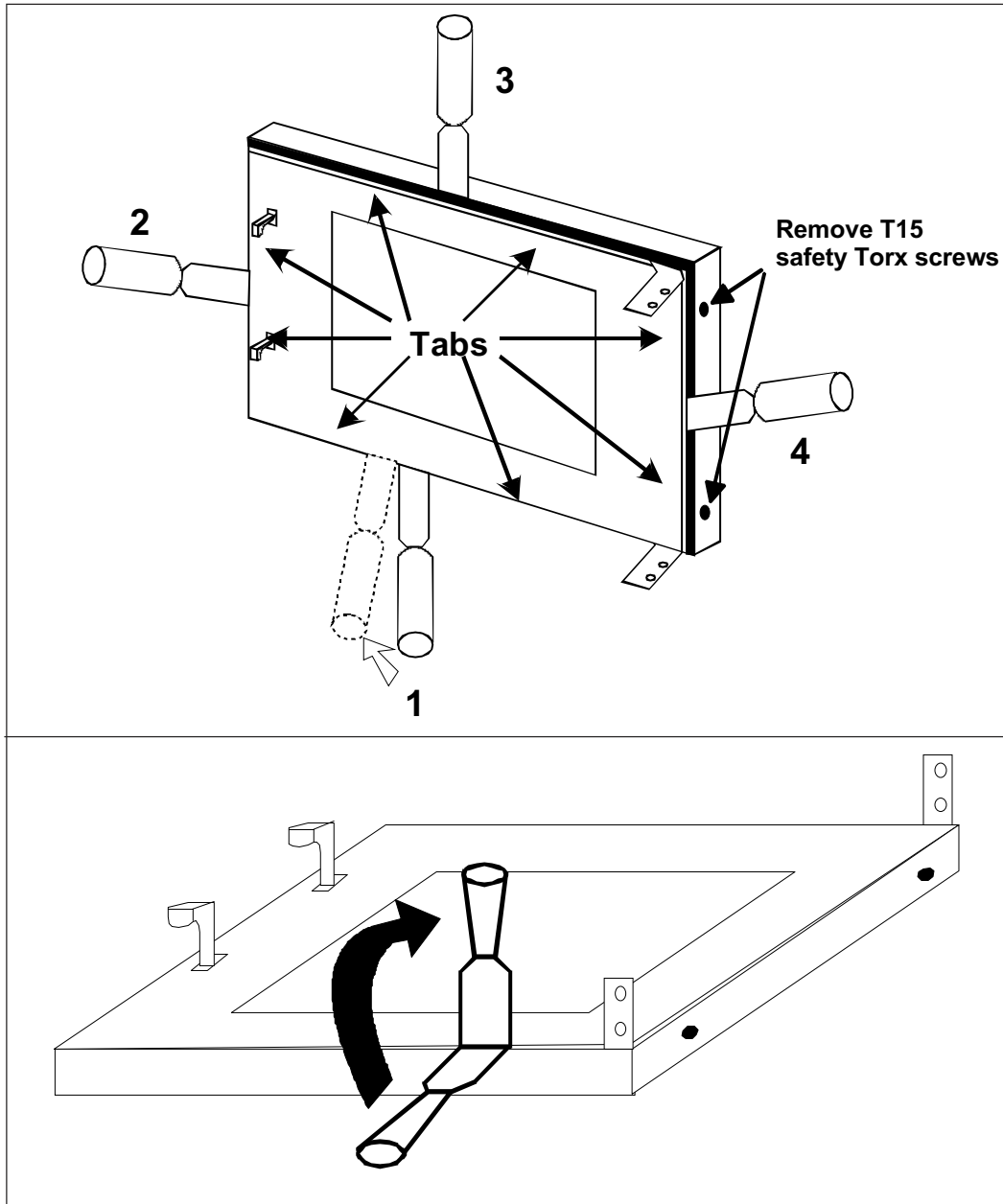

CAUTION

When glass retainer is removed, be careful glass does not fall out of frame.

Disassembly

WARNING

To avoid risk of electrical shock, personal injury or death; disconnect electrical power before servicing.

Switch Replacement / Door Adjustment

1. Remove and retain two (2) screws securing switch to cavity. Remove switch.
2. Position new switch assembly into cavity opening.
 - First, insert bottom ramp of switch into bottom opening.
 - Tilt switch upward and insert top ramp of switch into top opening.
 - Be sure both ramps are fully protruded through the front frame of cavity.

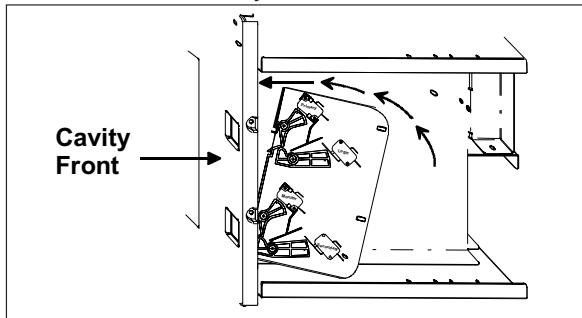

3. Loosely install screws removed in step 1.
4. Push and hold switch assembly towards front of oven and tighten screws.
5. Transfer wires to new switch.
6. Install wire ties.

Important: It is necessary to adjust the door assembly for correct switch function.

7. Tape shims [12382602](#) and 12019302 to door, as shown.

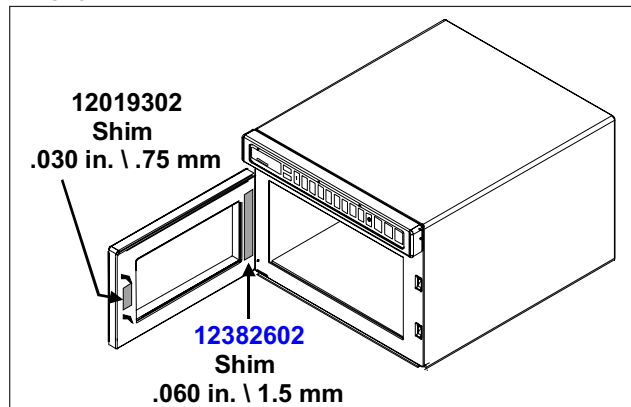

8. With door closed, loosen door hinge bolts 1/2 turn.
9. **Lift upward on door, using the door handle.**
10. With left hand, clamp door to cavity on hinge side of door.
11. While holding door in place, tighten 15/16" (8 mm) hinge bolts in the order shown. Use a wrench or socket to tighten securely.

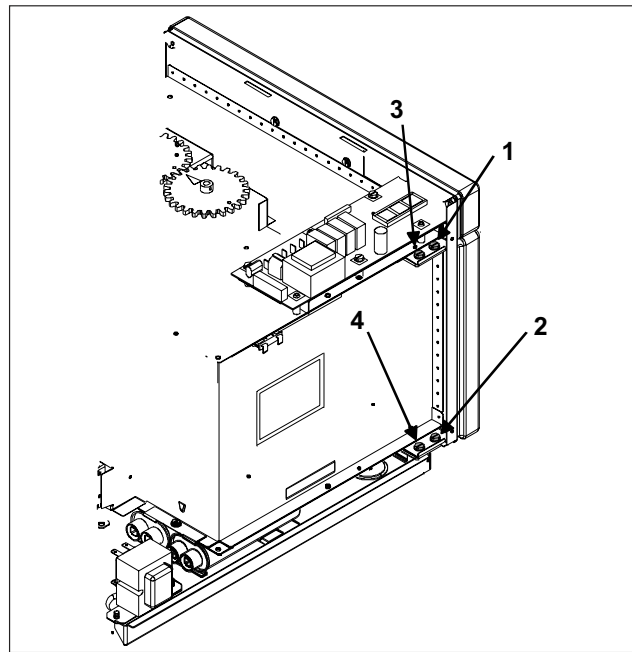

12. Open and close door several times to check switch operation.

NOTE: If switches do not activate, check condition and alignment of door and hinges.

13. Remove shims.

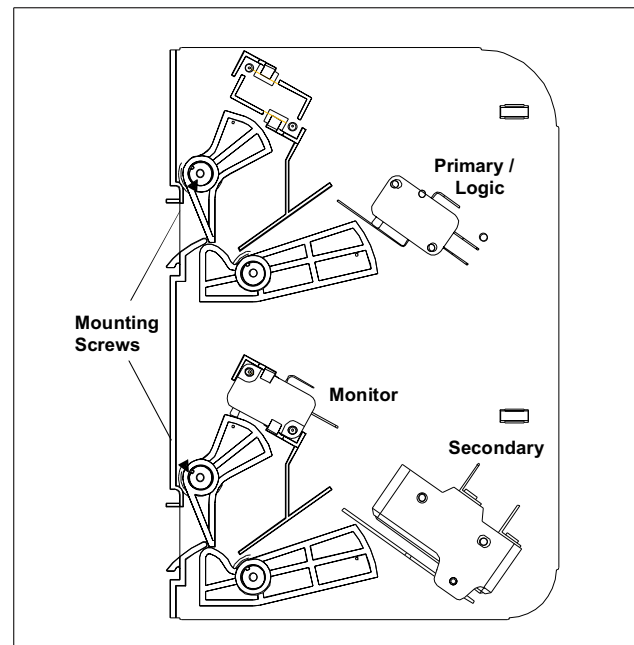

6

Capacitor/Diode Location

Capacitor / Diode location starting S/N 0902100848 and location prior to S/N 0902100848

Capacitor / Diode Location S/N 1103100152 and Earlier

Capacitor / Diode Location S/N 1103100153 and After

Capacitor / Diode Location

Capacitor / Diode location starting S/N 0902100848 and location prior to S/N 0902100848

* Use caution when looking up parts to assure you get the correct diode.

Img	Ref	PartNumber	Series	Description	Qty	Note	
1	7	13091701		DIODE	2	Note ←	Used starting at serial number 0902100848
1	7	R9800022		KIT, DIODE	2	Note ←	Used prior to serial number 0902100848

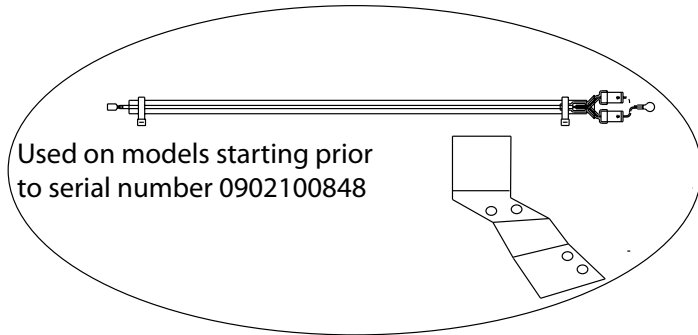

Flow divider is removed on this configuration to improve airflow to short lead diode.

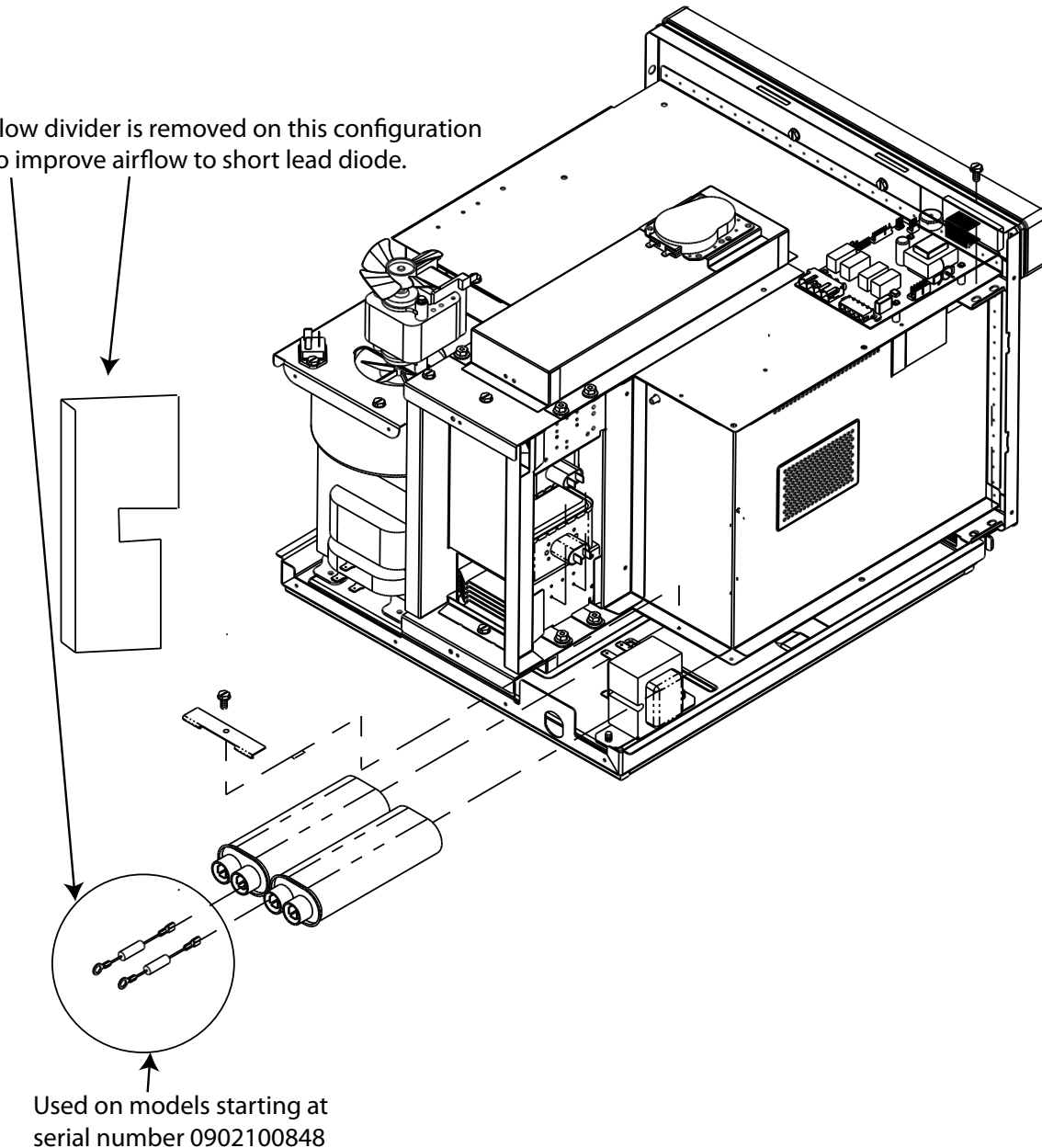

Capacitor / Diode Location S/N 1103100152 and Earlier

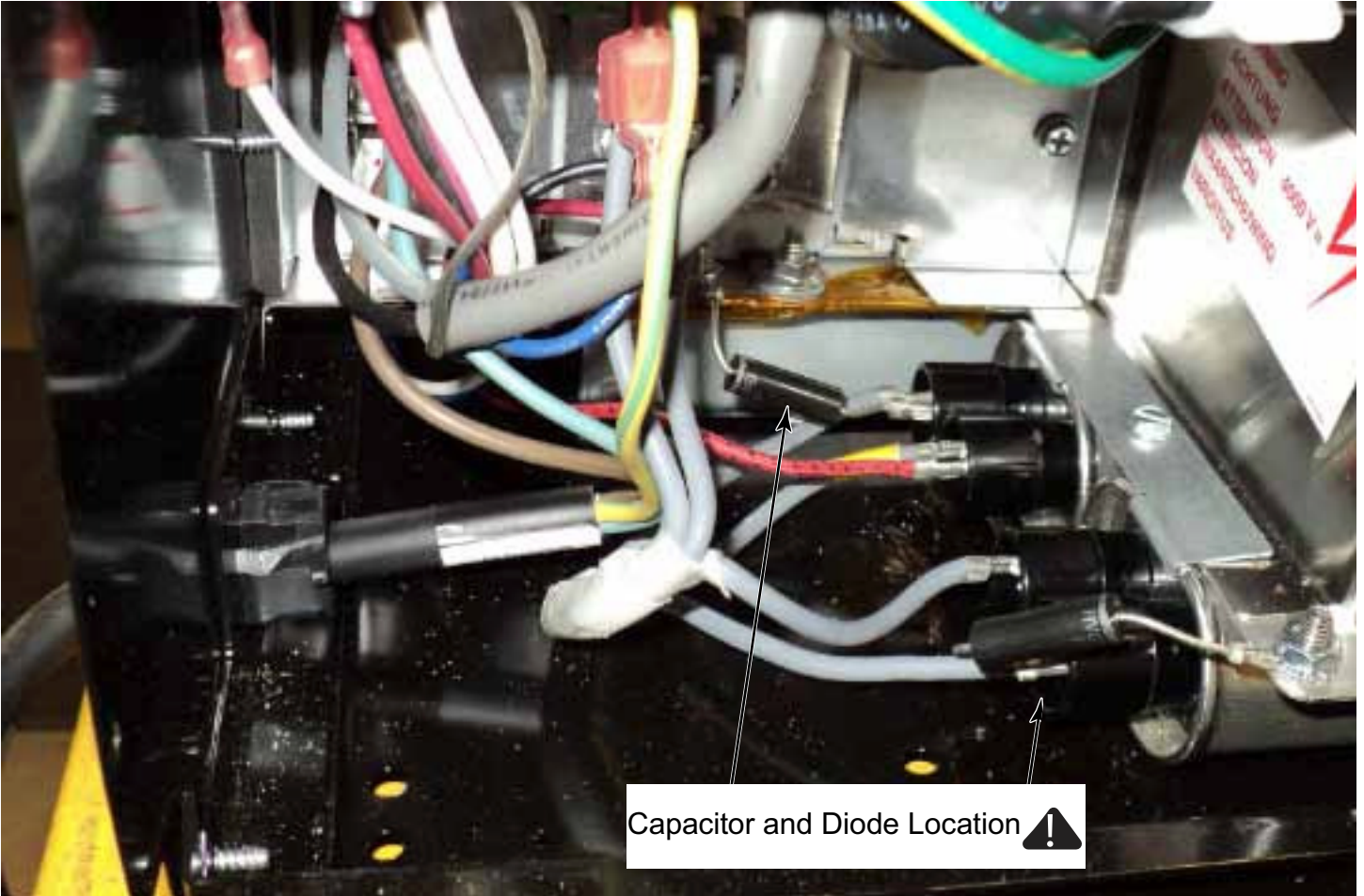

Capacitor and Diode Location ⚠

⚠ DANGER
High Voltage Components

Capacitor / Diode Location S/N 1103100153 and After

View of right side facing oven



Interlock
Assembly

View of left side facing oven

HV Transformer



 **DANGER**
High Voltage Components

7 | **Airflow**

Airflow

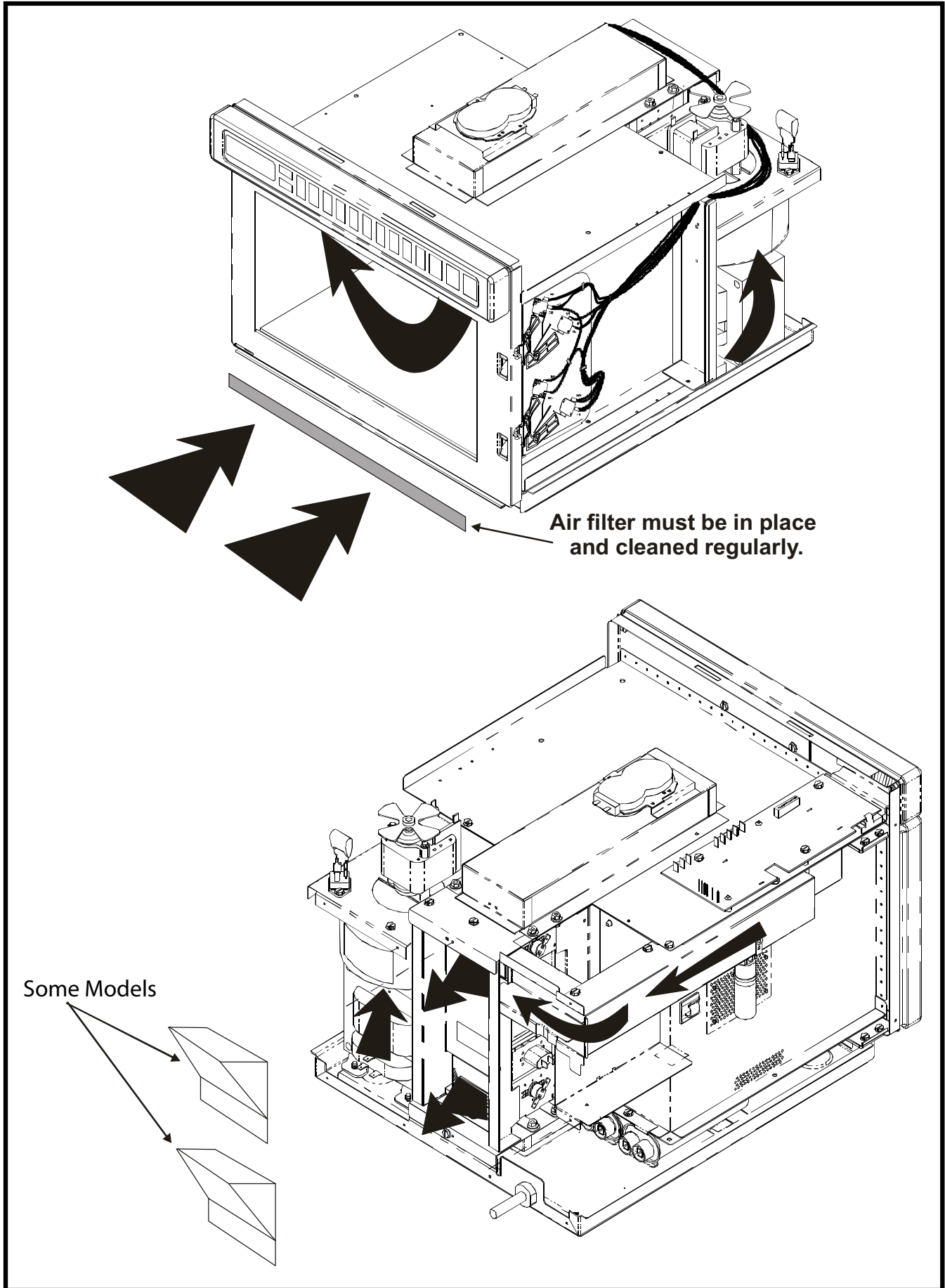

8 | **Component Testing Procedures**

Component Testing Procedures

⚠ WARNING

To avoid risk of electrical shock, personal injury or death, disconnect power to oven and discharge capacitor before servicing, unless testing requires power.

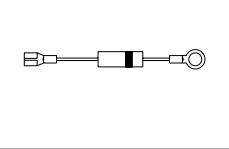
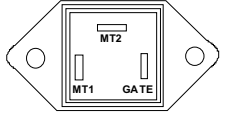
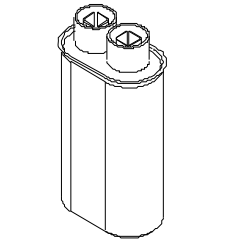
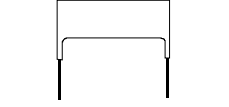
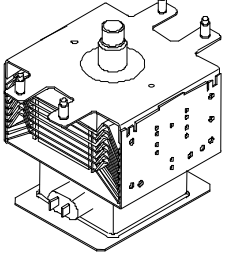
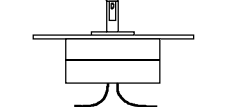
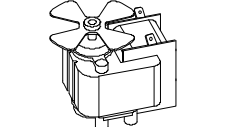
Illustration	Component	Test	Results
	Thermal Cutout	Disconnect all wires from TCO. Measure resistance across terminals. Cavity Thermal Fuse Magnetron TCO	Open at 219° F (104° C). Open at 280° F (138° C) and closed at 180° F (82° C).
	Diode Assembly	Discharge Capacitors Remove diode lead from capacitor and connect ohmmeter. Reverse leads for second test.	Infinite resistance should be measured in one direction and 50KΩ or more in the opposite direction. NOTE: Test meter must contain a battery of 6 volts minimum.
	Triac	Disconnect wires to triac. Measure resistance from: MT1 to MT2 MT1 to Gate MT2 to Gate All terminals to ground..... Output drive voltage to triac Triac terminals..... Gate—T1	Caution - Do not operate oven with wire to terminal MT2 removed. Infinite. Approximately 40 Ω or more. Infinite. Infinite. 0 VAC (Idle and Standby) 0.9 VAC (Cook)
	Capacitor	Discharge Capacitors Remove wires from capacitor terminals and connect ohmmeter, set on highest resistance scale to terminals. Also check between each terminal and capacitor case.	Between Terminals: Meter should momentarily deflect towards zero then return to over 5 MΩ. If no deflection occurs, or if continuous deflection occurs, replace capacitor. Terminal to Case: Infinite resistance.
	Snubber Assembly	Disconnect wires to snubber. Measure resistance across terminals.....	Infinite.
	Magnetron	Discharge Capacitors Remove wires from magnetron and connect ohmmeter to terminals. Also check between each terminal and ground.	Between Terminals: Less than 1 Ω. Each terminal to ground measures Infinite resistance. NOTE: This test is not conclusive. If oven does not heat and all other components test good replace the magnetron and retest.
	Stirrer Motor	Remove all wires from terminals. Measure resistance from: Terminal to terminal	Approximately 25 KΩ.
	Blower Motor	Remove all wires from motor. Measure resistance across coil (OR- WH).....	Approximately 30 Ω.

Component Testing Procedures

⚠ WARNING

To avoid risk of electrical shock, personal injury or death, disconnect power to oven and discharge capacitor before servicing, unless testing requires power.

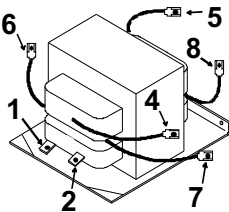
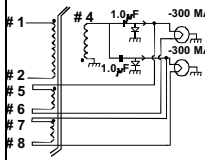
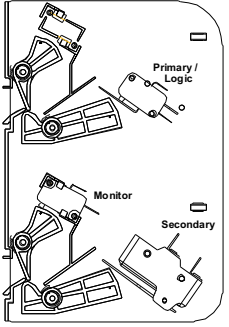
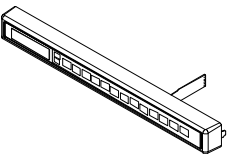
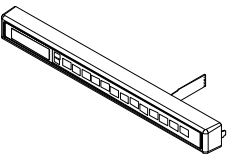
Illustration	Component	Test	Results																																																
 <p>Terminal 1 – 230 V Terminal 2 – Common</p>	Transformer	<p>Discharge Capacitors Remove all wires from terminals. Measure resistance from:</p> <p>Terminal 1 to 2..... Terminal 5 to 6..... Terminal 7 to 8..... Terminal 4 to Ground screw..... Terminal 4 to any other terminal.....</p> <div style="text-align: center;">  </div>	<p>1.0 Ω. Less than 1 Ω. Less than 1 Ω. 30 Ω. ← Infinite resistance. If not, replace transformer.</p> <div style="border: 1px solid black; padding: 2px; width: fit-content; margin-left: 20px;"> <p>Sample - Refer to Product Tech Sheet for proper Ohm resistance value.</p> </div>																																																
	Interlock switch assembly	<p>Disconnect wires to switch.</p> <p>With door open measure resistance from:</p> <p>Terminal C to NC Monitor..... Terminal C to NO Primary / Logic..... Terminal C to NO Secondary.....</p> <p>With door closed measure resistance from:</p> <p>Terminal C to NC Monitor..... Terminal C to NO Primary / Logic..... Terminal C to NO Secondary.....</p> <div style="text-align: center;"> <p>Door Closed</p> <p>Primary / Logic C —●— NO</p> <p>Monitor C —●— NC</p> <p>Secondary C —●— NO</p> </div>	<p>Continuity. Infinite. Infinite. Infinite. Continuity. Continuity.</p>																																																
	Touch Panel Assembly	<p>Continuity is indicated as 100 Ω and below.</p> <p>Pin 1: Ground.</p> 	<table border="1"> <thead> <tr> <th>Pad</th> <th>Pins</th> <th>Measurement</th> </tr> </thead> <tbody> <tr><td>1</td><td>8 & 10</td><td>Continuity</td></tr> <tr><td>2</td><td>7 & 10</td><td>Continuity</td></tr> <tr><td>3</td><td>6 & 10</td><td>Continuity</td></tr> <tr><td>4</td><td>5 & 10</td><td>Continuity</td></tr> <tr><td>5</td><td>4 & 10</td><td>Continuity</td></tr> <tr><td>6</td><td>3 & 10</td><td>Continuity</td></tr> <tr><td>7</td><td>8 & 9</td><td>Continuity</td></tr> <tr><td>8</td><td>7 & 9</td><td>Continuity</td></tr> <tr><td>9</td><td>6 & 9</td><td>Continuity</td></tr> <tr><td>0</td><td>5 & 9</td><td>Continuity</td></tr> <tr><td>Start</td><td>4 & 9</td><td>Continuity</td></tr> <tr><td>Stop/Reset</td><td>4 & 8</td><td>Continuity</td></tr> <tr><td>Power Level</td><td>5 & 8</td><td>Continuity</td></tr> <tr><td>X 2</td><td>6 & 8</td><td>Continuity</td></tr> <tr><td>Time Entry</td><td>7 & 8</td><td>Continuity</td></tr> </tbody> </table>	Pad	Pins	Measurement	1	8 & 10	Continuity	2	7 & 10	Continuity	3	6 & 10	Continuity	4	5 & 10	Continuity	5	4 & 10	Continuity	6	3 & 10	Continuity	7	8 & 9	Continuity	8	7 & 9	Continuity	9	6 & 9	Continuity	0	5 & 9	Continuity	Start	4 & 9	Continuity	Stop/Reset	4 & 8	Continuity	Power Level	5 & 8	Continuity	X 2	6 & 8	Continuity	Time Entry	7 & 8	Continuity
Pad	Pins	Measurement																																																	
1	8 & 10	Continuity																																																	
2	7 & 10	Continuity																																																	
3	6 & 10	Continuity																																																	
4	5 & 10	Continuity																																																	
5	4 & 10	Continuity																																																	
6	3 & 10	Continuity																																																	
7	8 & 9	Continuity																																																	
8	7 & 9	Continuity																																																	
9	6 & 9	Continuity																																																	
0	5 & 9	Continuity																																																	
Start	4 & 9	Continuity																																																	
Stop/Reset	4 & 8	Continuity																																																	
Power Level	5 & 8	Continuity																																																	
X 2	6 & 8	Continuity																																																	
Time Entry	7 & 8	Continuity																																																	
Wire Harness		Test continuity of wires	Continuity.																																																

Component Testing Procedures



WARNING

To avoid risk of electrical shock, personal injury or death, disconnect power to oven and discharge capacitor before servicing, unless testing requires power.

Invensy Control Board

Illustration	Component	Test	Results
	Control board P1 connector used for touch panel ribbon	Line voltage to control board P2 connector Pin 1—Pin 3..... Output drive voltage to triac Triac terminals..... Gate—T1..... Fan relay (controls blower motor, antenna motor(s), and oven light) Control board Terminals C—J..... Cook relay Control board Terminals F—K.....	Line voltage (All Conditions). 0 VAC (Idle and Standby). 0.9 VAC (Cook). Line voltage (Idle). 0 VAC (Standby and Cook). Line voltage (Idle). 0 volts (Standby and Cook).

CPI Control Board

Illustration	Component	Test	Results
	Control board P1 connector used for touch panel ribbon	Line voltage to control board E1 (RD) —L2 (BU) Output drive voltage to triac Triac terminals..... Gate (BR) —T1 (BK)..... 230 VAC line voltage Fan relay (controls blower motor, antenna motor(s), and oven light) Control board..... Terminals L2 (BU) —J2-7 (OR)..... Control board..... Terminals E1 (RD) —E4 (PK).....	Line voltage (All Conditions) 0 VAC (Idle and Standby) 0.9 VAC (Cook) Line voltage (Idle) 0 VAC (Standby and Cook) Line voltage (Idle) 0 volts (Standby and Cook)

Component Testing Procedures

Error Code Table

Error Code	Corrective Action
F1	Replace HV/LV Board
F2	Replace HV/LV Board
F3	Replace HV/LV Board
F4	Replace HV/LV Board
F5	Replace Touch Panel
F6	Replace HV/LV Board

Usage Test

The Usage Test is used to access Magnetron Hours, Magnetron Cycles and Door Cycles. Use the following procedure to access the data:

1. Open door.
2. Press and hold pad **3** for five (5) seconds.
NOTE: After five (5) seconds, SErv illuminates in the display.
3. Press pad **1** for Magnetron Hours.
4. Press pad **2** for Magnetron Cycles.
5. Press pad **3** for Door Cycles.

Conditions

Initial Power Up Condition: Apply power to oven with door closed.

Idle Condition: Oven plugged in, display blank (no other components operating).

Standby Condition: Open oven door, light and motors operate.

Cook Condition: Food load in oven, cook cycle initiated.

Component Testing Procedures



WARNING

To avoid risk of electrical shock, personal injury or death, disconnect power to oven and discharge capacitor before servicing, unless testing requires power.

All ACP microwave oven power outputs are rated using the IEC705 standards. Using the IEC705 test method requires precision measurements and equipment that is not practical to be performed in the field. Using the test shown below will indicate if the oven performance is satisfactory.

Test equipment required:

- 1000 ml test container and thermometer.
- Digital watch / watch with a second hand for use on ovens with electromechanical timers.

Important Notes:

- Low line voltage will cause low temperature rise / power output.
- Ovens must be on a dedicated circuit, properly grounded, and polarized. Other equipment on the same circuit may cause a low temperature rise / power output.
- This test and results are not a true IEC705 test procedure and are only intended to provide servicers with an easy means of determining if the microwave oven cooking output is correct.

Procedure

1. Fill the test container to the 1000 ml line with cool tap water.

NOTE: Water temperature should be approximately 60° F / 16° C.

2. Using the thermometer, stir water for five to ten seconds; measure, and record the temperature (T1).
3. Place test container of water in the center of oven cavity and close door.
4. Heat the water for a 33-second full power cycle.

NOTE: Use a digital watch or a watch with a second hand for ovens with electromechanical timers.

5. At end of the cycle, remove test container. Using the thermometer, stir water for five to ten seconds and record temperature (T2).
6. Subtract the starting water temperature (T1), from the ending water temperature (T2) to obtain the temperature rise (ΔT).
7. If the temperature rise (ΔT) meets or exceeds the minimum, the test is complete. If the temperature rise (ΔT) fails to meet the minimum temperature rise, test the line voltage to verify it is correct. Then repeat steps 1 - 6 making sure to change the water. If the temperature rise (ΔT) fails to meet the minimum temperature rise again the oven will require service.

Minimum Temperature Rise at Thirty -Three (33) Seconds Run Time

ΔT (°F)	Cooking Power Output	ΔT (°F)	Cooking Power Output	ΔT (°C)	Cooking Power Output	ΔT (°C)	Cooking Power Output
10.....	1000	20	2000	5	1000	11	2000
11.....	1100	21	2100	5.5.....	1100	11.5.....	2100
12.....	1200	22	2200	6.5.....	1200	12	2200
14.....	1400	24	2400	7.5.....	1400	13	2400
17.....	1700	25	2500	9.5.....	1700	13.5.....	2500
18.....	1800	27	2700	10.....	1800	15	2700
19.....	1900	30	3000	10.5.....	1900	16.5.....	3000

9 | Troubleshooting

Initial Power Up

Standby Condition

Cook Condition

Troubleshooting

Initial Power Up

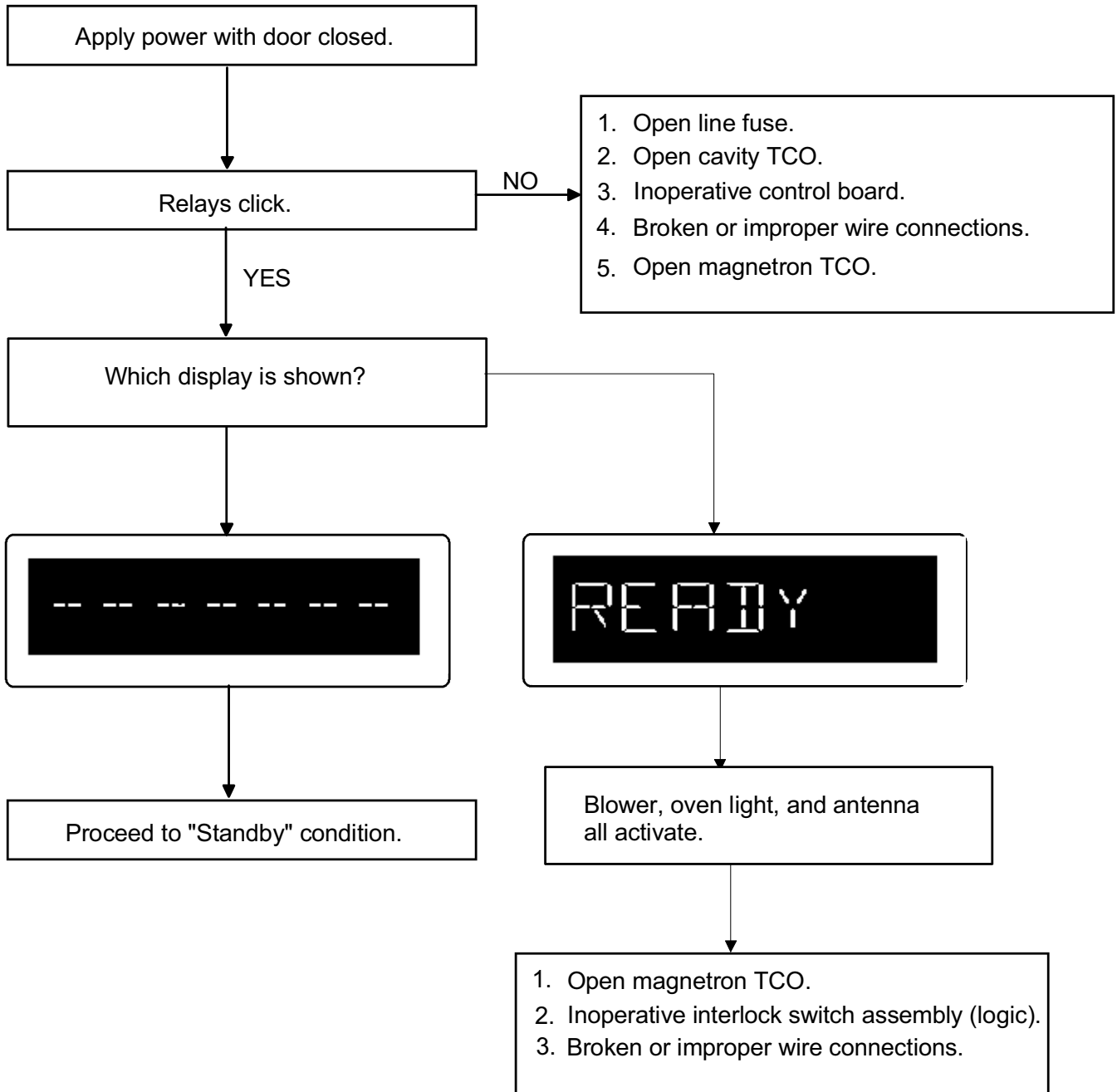

Troubleshooting

Standby Condition

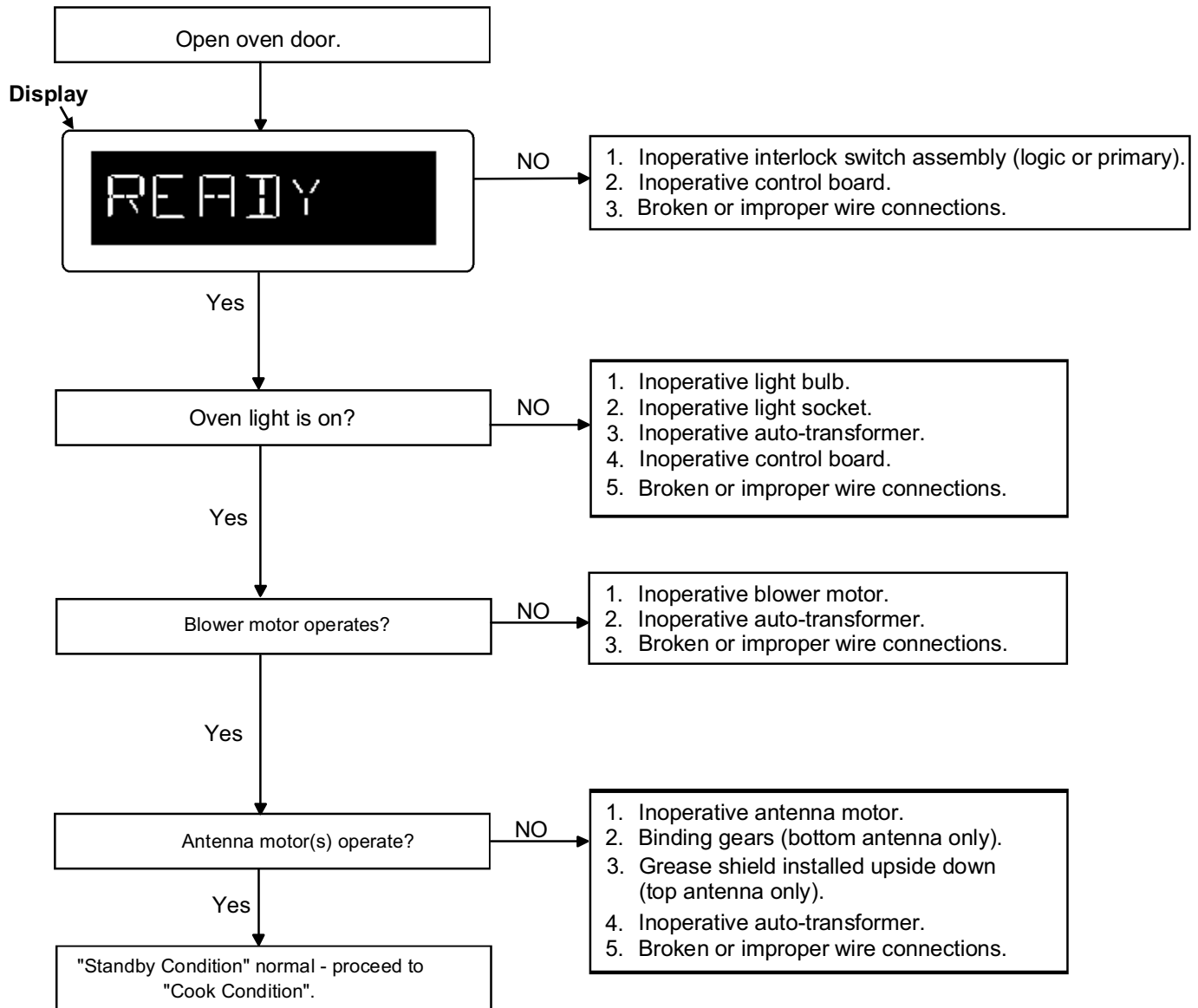

Troubleshooting

Cook Condition

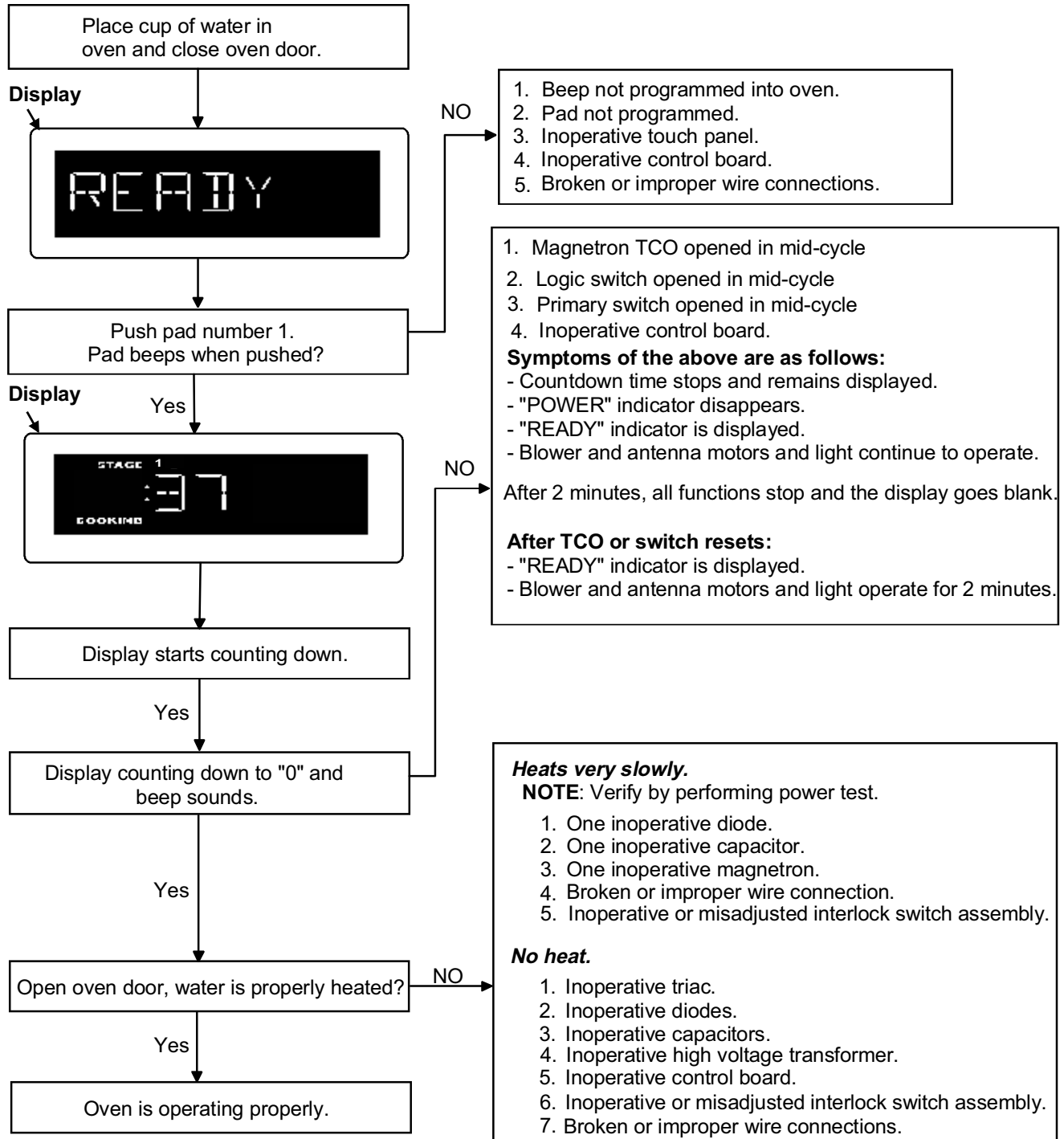

NOTE: Shut down after cook cycle - door closed - factory preset at 60 seconds, but can be changed with user options.
Shut down, door open - approximately 2 minutes.
After shut down, display goes blank.

10 | **Wiring Diagrams / Schematics**

Wiring Diagram

DEC11E2 Sample w/ CPI Control Current Production started at S/N 0911102348



WARNING

To avoid risk of electrical shock, personal injury or death, disconnect power to oven and discharge capacitor before servicing, unless testing requires power.

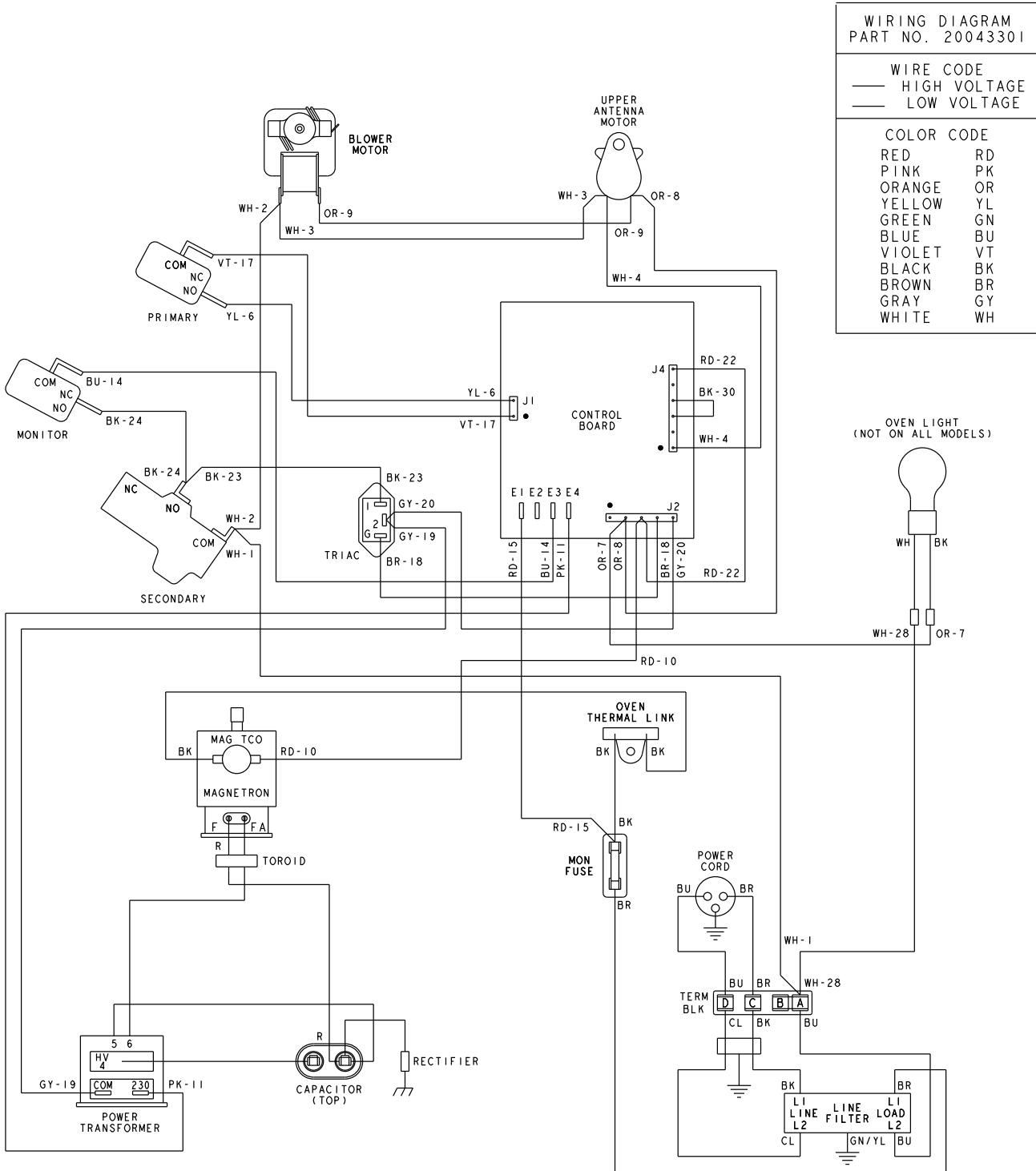

Schematic Diagram

DEC11E2 Sample w/ CPI Control Current Production started at S/N 0911102348

⚠ WARNING

To avoid risk of electrical shock, personal injury or death, disconnect power to oven and discharge capacitor before servicing, unless testing requires power.

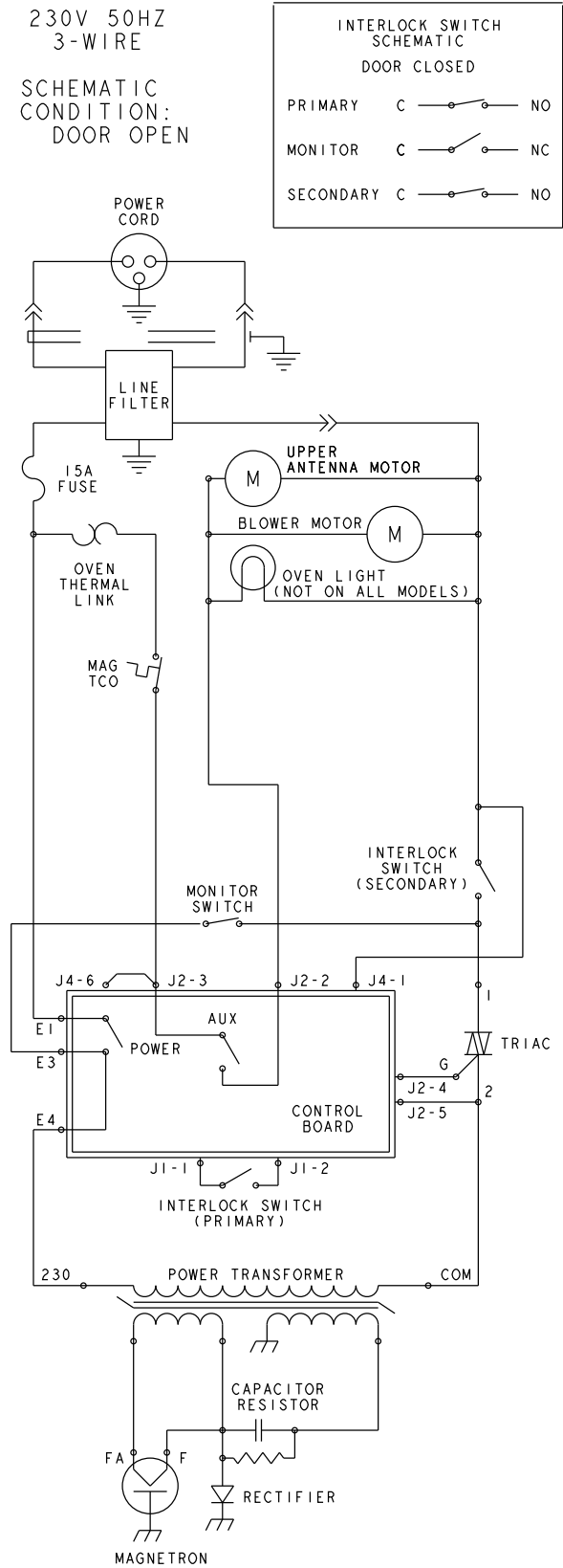

Wiring Diagram

DEC11E2 Sample w/ Invensy Control Current Production ending at S/N 0911102347



WARNING

To avoid risk of electrical shock, personal injury or death, disconnect power to oven and discharge capacitor before servicing, unless testing requires power.

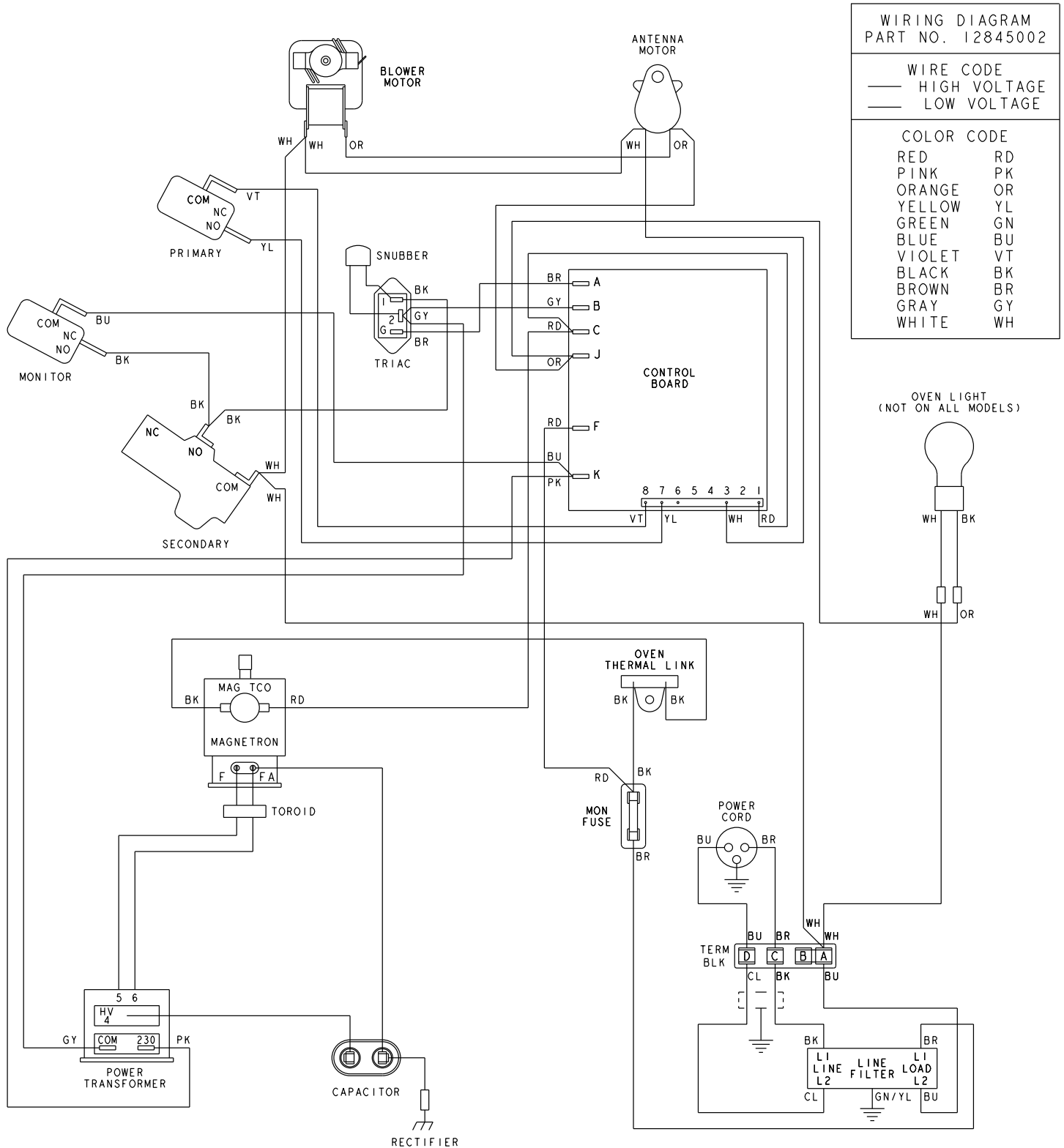

Schematic Diagram

DEC11E2 Sample w/ Invensy Control Current Production ending at S/N 0911102347



WARNING

To avoid risk of electrical shock, personal injury or death, disconnect power to oven and discharge capacitor before servicing, unless testing requires power.

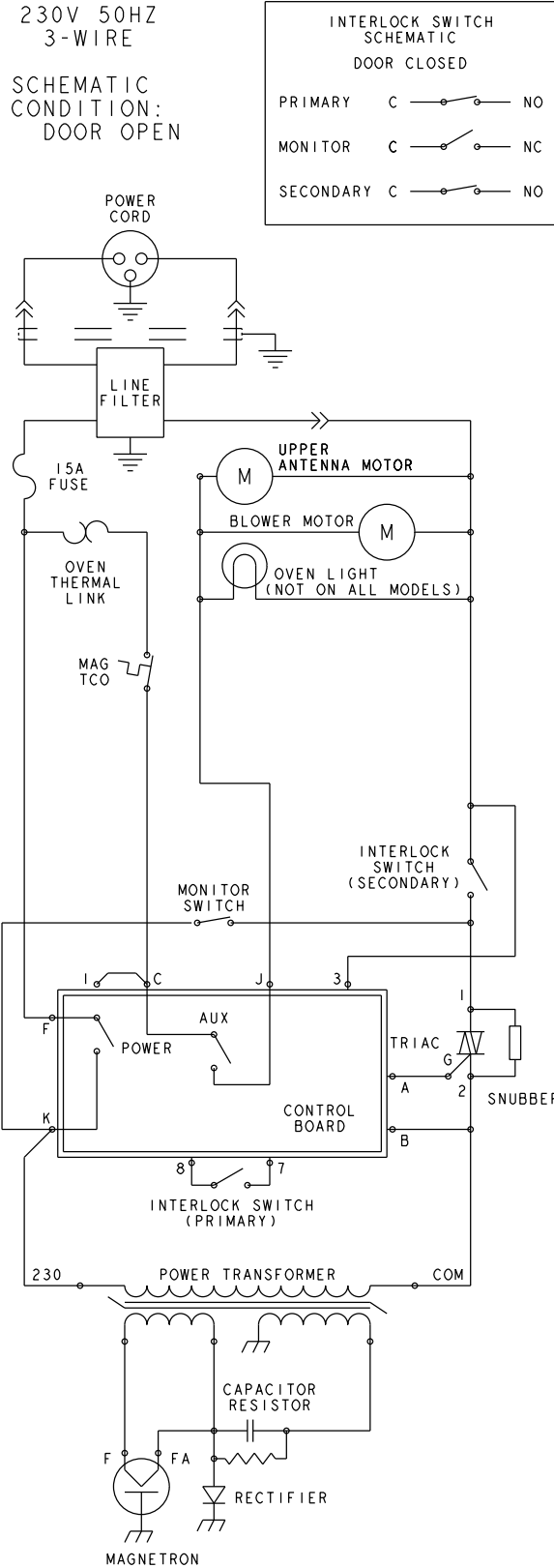

Wiring Diagram

DEC18E2 Sample w/ CPI Control started at S/N 0911102348



WARNING

To avoid risk of electrical shock, personal injury or death, disconnect power to oven and discharge capacitor before servicing, unless testing requires power.

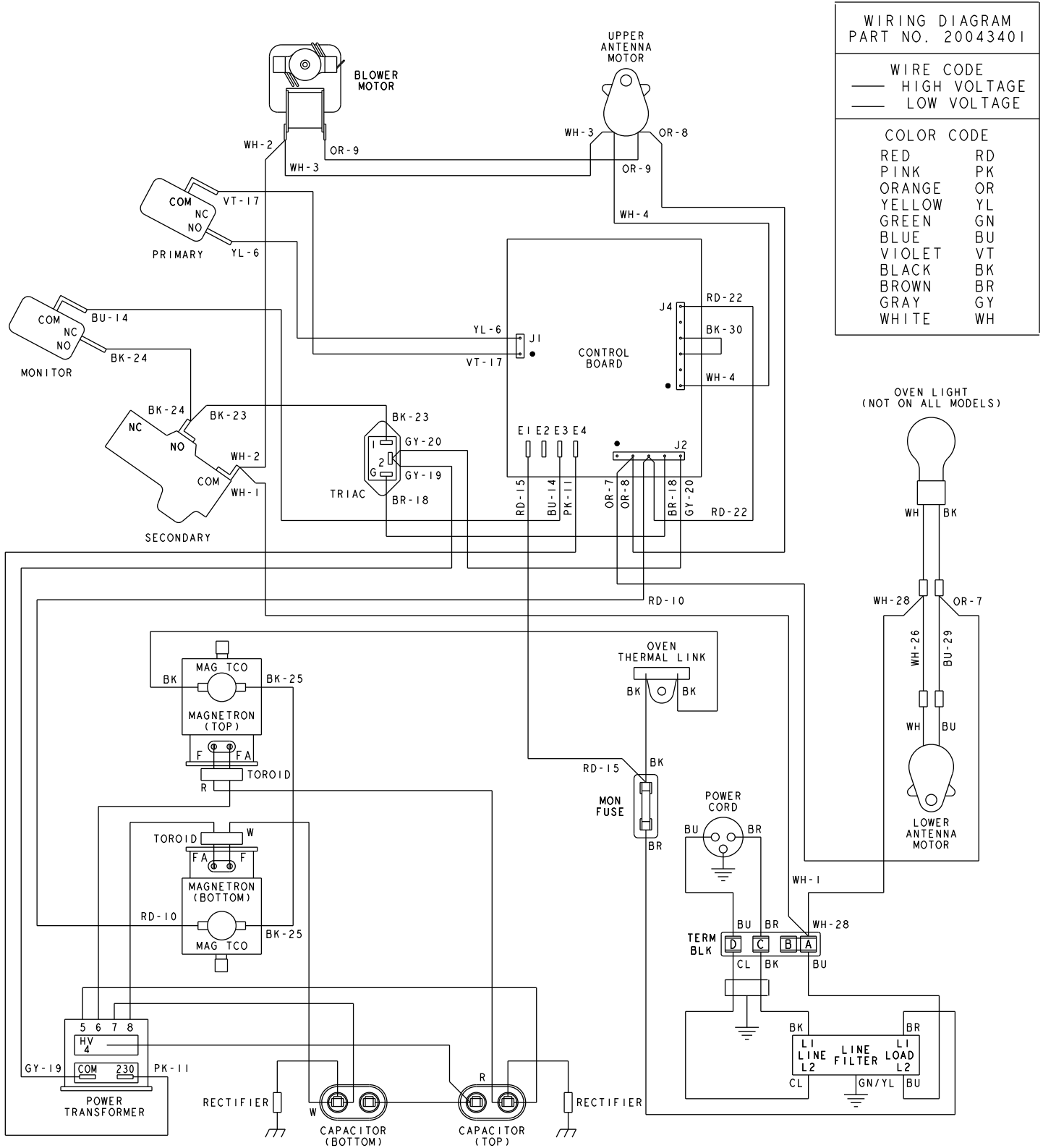

WIRING DIAGRAM
PART NO. 20043401

WIRE CODE
 — HIGH VOLTAGE
 — LOW VOLTAGE

COLOR CODE

RED	RD
PINK	PK
ORANGE	OR
YELLOW	YL
GREEN	GN
BLUE	BU
VIOLET	VT
BLACK	BK
BROWN	BR
GRAY	GY
WHITE	WH

OVEN LIGHT
(NOT ON ALL MODELS)

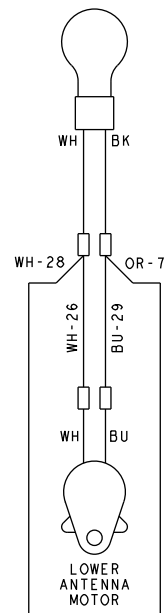

Schematic Diagram

DEC18E2 Sample w/ CPI Control started at S/N 0911102348



WARNING

To avoid risk of electrical shock, personal injury or death, disconnect power to oven and discharge capacitor before servicing, unless testing requires power.

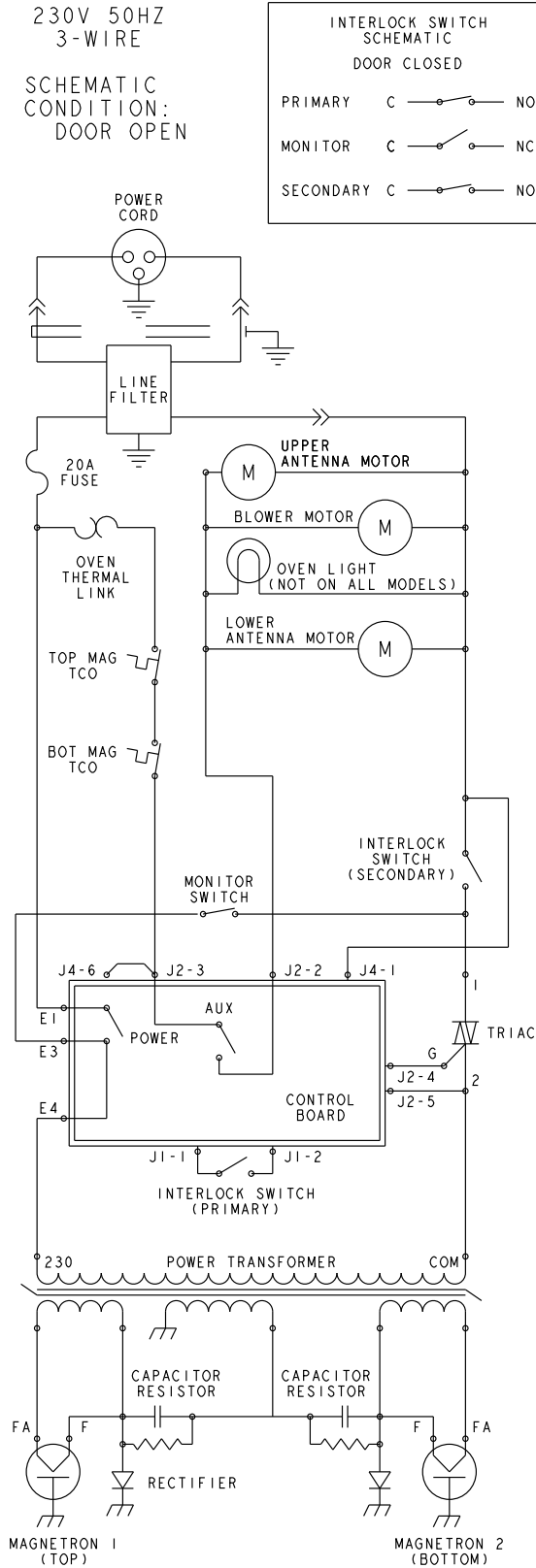

Schematic Diagram

DEC18E2 Sample w/ Inveny Control ended at S/N 0911102347



WARNING

To avoid risk of electrical shock, personal injury or death, disconnect power to oven and discharge capacitor before servicing, unless testing requires power.

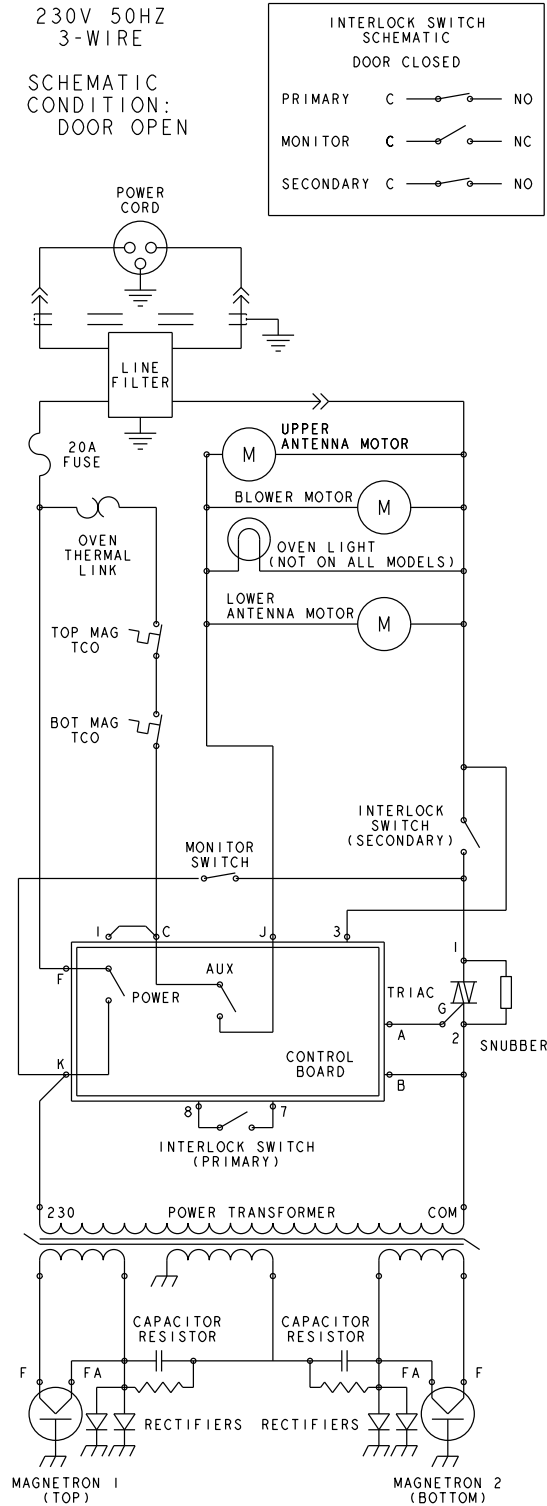

Notes

