

**Amana**<sup>®</sup>

**MENUMASTER**<sup>®</sup>  
**COMMERCIAL MICROWAVE OVEN**

# Service

This manual is to be used by qualified appliance technicians only. Maytag does not assume any responsibility for property damage or personal injury for improper service procedures done by an unqualified person.

## Commercial Combination/ Convection Microwave Oven

This Base Manual covers general information

Refer to individual Technical Sheet for information on specific models

This manual includes, but is not limited to the following:

### 60 HZ Models

AMH20	P1330801M
AMH202	P1331101M
AMH20D	P1332501M
JBH202	P1331102M
SZH20	P1331104M

### 50 HZ Models

AMH20A2	P1331103M
AMH20AD2	P1332504M
	P1332506M
MMH20AD2	P1332505M
	P1332507M

**MAYTAG**<sup>®</sup>

16023463  
November 2006

# Important Information

## Important Notices for Servicers and Consumers

Maytag will not be responsible for personal injury or property damage from improper service procedures. Pride and workmanship go into every product to provide our customers with quality products. It is possible, however, that during its lifetime a product may require service. Products should be serviced only by a qualified service technician who is familiar with the safety procedures required in the repair and who is equipped with the proper tools, parts, testing instruments and the appropriate service information. **IT IS THE TECHNICIANS RESPONSIBILITY TO REVIEW ALL APPROPRIATE SERVICE INFORMATION BEFORE BEGINNING REPAIRS.**



### **WARNING**

To avoid risk of severe personal injury or death, disconnect power before working/servicing on appliance to avoid electrical shock.

To locate an authorized servicer, please consult your telephone book or the dealer from whom you purchased this product. For further assistance, please contact:

### **Service Support Center**

Contact your local product distributor or visit the Web site at [www.amanacommercial.com](http://www.amanacommercial.com).

### **Recognize Safety Symbols, Words, and Labels**



### **DANGER**

**DANGER**—Immediate hazards which **WILL** result in severe personal injury or death.



### **WARNING**

**WARNING**—Hazards or unsafe practices which **COULD** result in severe personal injury or death.



### **CAUTION**

**CAUTION**—Hazards or unsafe practices which **COULD** result in minor personal injury, product or property damage.

# Table of Contents

Important Information .....	2	Side Touch Panel Assembly .....	28
Important Safety Information .....	4	Display Module .....	28
Grounding Instructions .....	7	Heating Elements (oven top) .....	28
Servicing of Grounded Products .....	8	Inlet Duct Assembly .....	28
Wiring .....	8	Halfwave Board .....	28
Proper Grounding and Polarization of 208/230 Volts Wall Outlets .....	8	Control Board Assembly Bracket .....	29
Explanation .....	8	High Voltage Circuit Board .....	29
Test Procedures (2 Methods) .....	8	Auto Transformer .....	29
General Test Information .....	8	Triacs .....	29
General Information		Power Relay .....	29
Unpacking Equipment .....	9	Convection Motor Capacitor .....	29
Equipment Placement .....	9	Magnetron .....	29
Radio Interference .....	9	Magnetron, Control, and Fan Thermal Cutouts (TCO) .....	30
Model Identification .....	9	Blower Bracket Assembly .....	30
Service .....	9	Microwave Blower Wheel and Motor .....	30
Parts and Accessories .....	9	Fan Blade .....	30
Troubleshooting Procedures .....	10-15	Transformer .....	30
Component Testing Procedures .....	16-19	Capacitor / Diode .....	31
Power Test .....	20	Convection Box .....	31
Convection Temperature Test and Calibration .....	21	Convection Element .....	31
Display Diagnostic .....	22	Thermal Limiter .....	31
Service Test .....	23	Plenum Box .....	31
Service Functions .....	24-25	Fuse .....	31
Disassembly Procedures		Power Cord .....	31
Door Handle .....	26	Component Location .....	32-34
Magnetic Door Stop .....	26	Appendix A	
Outer Door .....	26	Owner's Manual .....	A-2-A-16
Inner Door Assembly .....	26	Appendix B	
Hinge .....	26	Quick Reference Guide .....	B-2-B3
Outer Case .....	27		
Back Panel .....	27		
Interlock Switch Module .....	27		
Stirrer Motor and Antenna Gears .....	27		
RTD (Resistance Thermal Device) .....	28		
Top Touch Panel Assembly .....	28		

# Important Safety Information

## **WARNING**

Read the following information to avoid possible exposure to microwave radiation:

The basic design of the Amana Microwave Oven makes it an inherently safe device to both use and service. However, there are some precautions which should be followed when servicing the Radarange to maintain this safety. These are as follows:

1. Always operate the unit from an adequately grounded outlet. Do not operate on a two-wire extension cord.
2. Before servicing the unit (if unit is operable) perform the microwave leakage test.
3. The oven should never be operated if the door does not fit properly against the seal, the hinges or hinge bearings are damaged or broken; the choke is damaged, (pieces missing, etc.); or any other visible damage can be noted. Check the choke area to ensure that this area is clean and free of all foreign matter.
4. If the oven operates with the door open and produces microwave energy, take the following steps:
  - A. Tell the user not to operate the oven.
  - B. Contact Maytag Amana Manufacturing immediately.
5. Always have the oven disconnected when the outer case is removed except when making the "live" tests called for in the Service Manual. Do not reach into the equipment area while the unit is energized. Make all connections for the test and check them for tightness before plugging the cord into the outlet.
6. Always ground the capacitors on the magnetron filter box with an insulated-handle screwdriver before working in the high voltage area of the equipment compartment. Some types of failures will leave a charge in these capacitors and the discharge could cause a reflex action which could make you injure yourself.
7. Always remember that in the area of the transformer there is HIGH VOLTAGE. When the unit is operating keep this area clear and free of anything which could possibly cause an arc or ground, etc.
8. Do not for any reason defeat the interlock switches there is not valid reason for this action at any time; nor will it be condoned by Amana.
9. **IMPORTANT:** Before returning a unit to a customer, be sure to check for proper switch interlock action.
10. Before returning a unit to a customer, be sure that the door spacing is reasonably uniform along the top, bottom, and sides, and that it measure 1/8" (3 mm) or less.
11. The Amana Microwave Oven should never be operated with any components removed and/or bypassed or when any of the safety interlocks are found to be defective, or when any of the seal surfaces are defective, missing, or damaged.
12. All Amana Microwave Ovens meet all requirements of the radiation control for Health and Safety Act of 1968. Due to measurement uncertainties, the maximum leakage for the field will be 4mw/cm<sup>2</sup>.
13. To ensure that the unit does not emit excessive microwave leakage and to meet the Department of Health and Human Services guidelines, check the oven for microwave leakage using the Holaday HI1510, HI1501, or HI1710 leakage monitor as outlined in the instruction. The maximum leakage level allowed when following those instructions is 4mw/cm<sup>2</sup>.
14. If servicer encounters an emission reading over 4mw/cm<sup>2</sup>, the servicer is to cease repair and contact the Amana Service Department immediately for further direction. Amana Manufacturing will contact the proper Government Agency upon verification of the test results.

# Important Safety Information



## Recognize this symbol as a SAFETY message



### WARNING

When using electrical equipment, basic safety precautions should be followed to reduce the risk of burns, electrical shock, fire, or injury to persons.

1. **READ** all instructions before using equipment.
2. **READ AND FOLLOW** the specific “**PRECAUTIONS TO AVOID POSSIBLE EXPOSURE TO EXCESSIVE MICROWAVE ENERGY**”.
3. This equipment **MUST BE GROUNDED**. Connect only to properly GROUNDED outlet. See “**GROUNDED INSTRUCTIONS**”.
4. Install or locate this equipment **ONLY** in accordance with the installation instructions in this manual.
5. Some products such as whole eggs and sealed containers, for example, closed glass jars may explode and **SHOULD NOT** be **HEATED** in this oven.
6. Use this equipment **ONLY** for its intended use as described in this manual. Do not use corrosive chemicals or vapors in this equipment. This type of oven is specifically designed to heat or cook. It is not designed for industrial or laboratory use.
7. As with any equipment, **CLOSE SUPERVISION** is necessary when used by **CHILDREN**.
8. **DO NOT** operate this equipment if it has a damaged cord or plug, if it is not working properly, or if it has been damaged or dropped.
9. This equipment, including power cord, must be serviced **ONLY** by qualified service personnel. Special tools are required to service equipment. Contact nearest authorized service facility for examination, repair, or adjustment.
10. **DO NOT** cover or block filter or other openings on equipment.
11. **DO NOT** store this equipment outdoors. **DO NOT** use this product near water, for example, near a kitchen sink, in a wet basement, or near a swimming pool, and the like.
12. **DO NOT** immerse cord or plug in water.
13. Keep cord **AWAY** from **HEATED** surfaces.
14. **DO NOT** let cord hang over edge of table or counter.
15. See door cleaning instructions in “Care and Cleaning” section.
16. **For commercial use only.**



### CAUTION

To reduce risk of fire in the oven cavity:

- a. **DO NOT** overcook food. Carefully attend equipment if paper, plastic, or other combustible materials are placed inside the oven to facilitate cooking.
- b. Remove wire twist-ties from paper or plastic bags before placing bag in oven.
- c. **KEEP** oven **DOOR CLOSED**, turn oven off, and disconnect the power cord, or shut off power at the fuse or circuit breaker panel, if materials inside the oven should ignite. Fire may spread if door is opened.
- d. **DO NOT** use the cavity for storage. **DO NOT** leave paper products, cooking utensils, or food in oven.

## SAVE THESE INSTRUCTIONS

# Important Safety Information



## CAUTION

To avoid risk of personal injury or property damage, observe the following:

1. Briskly stir or pour liquids before heating with microwave energy to prevent spontaneous boiling or eruption. Do not overheat. If air is not mixed into a liquid, liquid can erupt in oven or after removal from oven.
2. Do not deep fat fry in oven. Fat could overheat and be hazardous to handle.
3. Do not cook or reheat eggs in shell or with an unbroken yolk using microwave energy. Pressure may build up and erupt. Pierce yolk with fork or knife before cooking.
4. Pierce skin of potatoes, tomatoes, and similar foods before cooking with microwave energy. When skin is pierced, steam escapes evenly.
5. Do not operate equipment without load or food in oven cavity.
6. Use only popcorn in packages designed and labeled for microwave use. Popping time varies depending on oven wattage. Do not continue to heat after popping has stopped. Popcorn will scorch or burn. Do not leave oven unattended.
7. Do not use regular cooking thermometers in oven. Most cooking thermometers contain mercury and may cause an electrical arc, malfunction, or damage to oven.
8. Do not heat baby bottles in oven.
9. Do not use metal utensils in oven.
10. Never use paper, plastic, or other combustible materials that are not intended for cooking.
11. When cooking with paper, plastic, or other combustible materials, follow manufacturer's recommendations on product use.
12. Do not use paper towels which contain nylon or other synthetic fibers. Heated synthetics could melt and cause paper to ignite.
13. Do not heat sealed containers or plastic bags in oven. Food or liquid could expand quickly and cause container or bag to break. Pierce or open container or bag before heating.
14. To avoid pacemaker malfunction, consult physician or pacemaker manufacturer about effects of microwave energy on pacemaker.

## ***PRECAUTIONS TO AVOID POSSIBLE EXPOSURE TO EXCESSIVE MICROWAVE ENERGY***

- a. **DO NOT** attempt to operate this oven with the door open since open-door operation can result in harmful exposure to microwave energy. It is important not to defeat or tamper with the safety interlocks.
- b. **DO NOT** place any object between the oven front face and the door or allow soil or cleaner residue to accumulate on sealing surfaces.
- c. **DO NOT** operate the oven if it is damaged. It is particularly important that the oven door close properly and that there is no damage to the: (1) door (bent), (2) hinges and latches (broken or loosened), (3) door seals and sealing surfaces.
- d. The oven should **NOT** be adjusted or repaired by anyone except properly qualified service personnel.

## SAVE THESE INSTRUCTIONS

# Important Safety Information

## **WARNING**

Precautions to be observed before and during servicing to avoid possible exposure to excessive microwave energy, or electrical shock disconnect power to oven.

- Do not operate or allow oven to be operated with door open.
- Make the following safety checks on all ovens to be serviced before activating the magnetron or other microwave source, and make repairs as necessary:
  - Interlock operation
  - Proper door closing
  - Seal and sealing surfaces (arcing, wear, and other damage)
  - Damage to or loosening of hinges and latches
  - Evidence of dropping or abuse
- Before turning on microwave power for any service test or inspection within the microwave generating compartments, check the magnetron, waveguide or transmission line, and cavity for proper alignment, integrity, and connections.
- Any failed or misadjusted components in the interlock, monitor, door seal, and microwave generation and transmission systems shall be repaired, replaced or adjusted by procedures described in this manual before oven is released to the consumer.
- Check microwave leakage to verify compliance with the federal performance standard should be performed on each oven prior to release to the consumer.

## **WARNING**

To avoid risk of electrical shock, injury or death; make sure these grounding instructions are followed.

## Grounding Instructions

### **WARNING**

Do not remove grounding prong when installing grounded appliance in a home or business that does not have three wire grounding receptacle, under no condition is grounding prong to be cut off or removed. It is the personal responsibility of the consumer to contact a qualified electrician and have properly grounded three prong wall receptacle installed in accordance with appropriate electrical codes.

### **WARNING**

To avoid the risk of electrical shock or death, do not alter the plug.

### **WARNING**

To avoid the risk of electrical shock or death, this equipment must be grounded.

This equipment **MUST** be grounded. In the event of an electrical short circuit, grounding reduces the risk of electric shock by providing an escape wire for the electric current. This oven is equipped with a cord having a grounding wire with a grounding plug. The plug must be plugged into an outlet that is properly installed and grounded.

Consult a qualified electrician or servicer if grounding instructions are not completely understood, or if doubt exists as to whether the equipment is properly grounded.

Do not use an extension cord. If the product power cord is too short, have a qualified electrician install a three-slot receptacle. This oven should be plugged into a separate 50 or 60 hertz circuit with the electrical rating as shown in the appropriate drawing. Models operate with a 208 or 230 supply voltage. When an oven is on a circuit with other equipment, an increase in cooking times may be required and fuses can be blown.

# Important Safety Information

## Servicing of Grounded Products

The standard accepted color coding for grounding wires is GREEN or GREEN WITH YELLOW STRIPE. These ground leads are NOT to be used as current carrying conductors. It is extremely important that the technician replace any and all grounds prior to completion of the service call. Under no condition should ground wire be left off causing a potential hazard to technicians and consumer.

## Wiring

A good service practice is never route wiring over terminals and/ or sharp edges. This applies to any wiring without regard to the circuit voltage. Wire installation material and thickness is designed and regulated for electrical spacing purpose only, but cannot always be relied upon because of possible cuts and/or abrasions, which can occur during servicing.

### **WARNING**

To avoid risk of electrical shock, personal injury or death; verify the oven is properly grounded and polarized.

## Proper Grounding and Polarization of 208/230 Volts Wall Outlets

For the safety of our customers and the service technician ALL appliances have a three-prong power cord and MUST be connected to a properly polarized and grounded wall outlet.

This information was written for those who do not understand grounding and polarization of a wall outlet.

A 208/230 volt wall outlet must always be wired as shown below.

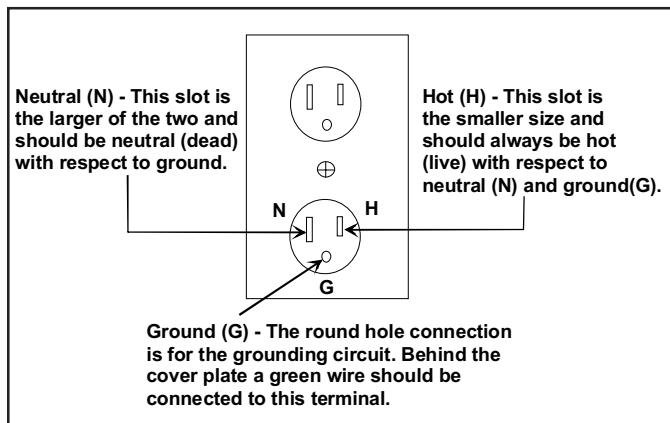

## Explanation

**Polarization**—This means that the larger slot must be neutral and the small slot must be hot (live).

**Mispolarized**—The outlet is miswired so that the larger slot is hot (live) and the smaller slot is neutral.

**Grounded**—This means the round hole connection is connected to earth ground through a connection to the main power panel.

**Ungrounded**—The round hole connection is not complete to earth ground and/or the main power panel.

### **CAUTION**

To avoid risk of electrical shock, personal injury or property damage; wiring changes or grounding of wall outlet are to be made only by a qualified electrician.

## General Test Information

Most testing in the manual is conducted with an ohmmeter using a multiplier scale of X 10k (k—thousand ohms). When using this scale, it is important that your fingers do not touch the metal parts of the test probes. To do so will give a false indication of the ohm reading.

# General Information

## Unpacking Equipment

- Inspect oven for damage such as dents in door or inside oven cavity.
- Report any dents or breakage to source of purchase immediately. **Do not attempt to use oven if damaged.**
- Remove all packing materials from oven interior.
- If oven has been stored in extremely cold area, wait a few hours before connecting power.

## Equipment Placement

- Recommended countertop surface depth is 26" (66 cm).
- Do not install oven next to or above source of heat, such as pizza oven or deep fat fryer. This could cause microwave oven to operate improperly and could shorten life of electrical parts.
- Do not block or obstruct oven filter. Allow access for cleaning.
- Install oven on level countertop surface.
- Outlet should be located so that plug is accessible when oven is in place.

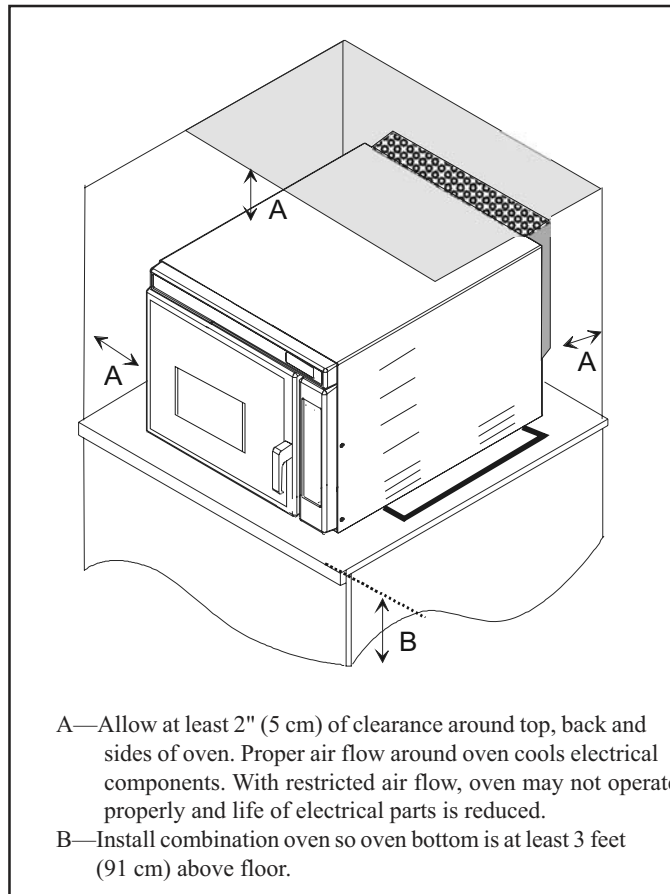

## Radio Interference

Microwave operation may cause interference to radio, television, or similar equipment. Reduce or eliminate interference by doing the following:

- Clean door and sealing surfaces of oven according to instructions in "Care and Cleaning" section.
- Place radio, television, etc. as far as possible from oven.
- Use a properly installed antenna on radio, television, etc. to obtain stronger signal reception.

## Model Identification

- For Amana product call 1-866-426-2621 or visit the Web Site at [www.amanacommercial.com](http://www.amanacommercial.com)

When contacting for service support, provide product information located on rating plate. Record the following:

Model Number: \_\_\_\_\_  
Manufacturing Number: \_\_\_\_\_  
Serial or S/N Number: \_\_\_\_\_  
Date of purchase: \_\_\_\_\_  
Dealer's name and address: \_\_\_\_\_

## Service

Keep a copy of sales receipt for future reference or in case warranty service is required. To locate an authorized servicer:

- For Amana product call 1-866-426-2621 or visit the Web Site at [www.amanacommercial.com](http://www.amanacommercial.com)
- Warranty service must be performed by an authorized servicer. We also recommend contacting an authorized servicer, if service is required after warranty expires.

## Parts and Accessories

Purchase replacement parts and accessories over the phone. To order accessories for your product contact your local product distributor or visit the Web site at [www.amanacommercial.com](http://www.amanacommercial.com).

# 60 Hz Troubleshooting Procedures



**WARNING**

To avoid risk of electrical shock, personal injury or death; disconnect power to oven and discharge capacitor before servicing, unless testing requires power.

## Stand By Condition

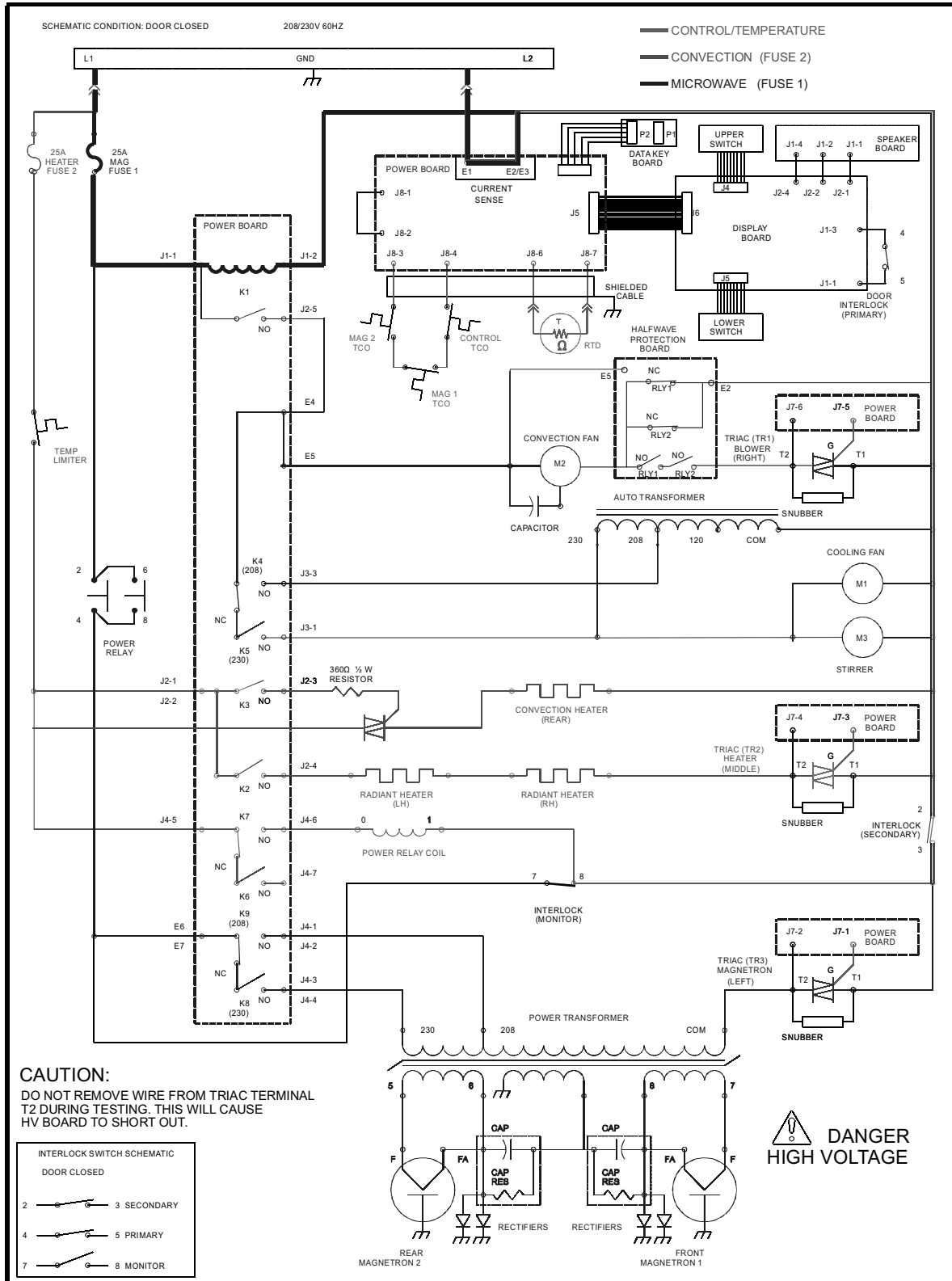

# 60 Hz Troubleshooting Procedures



## WARNING

To avoid risk of electrical shock, personal injury or death; disconnect power to oven and discharge capacitor before servicing, unless testing requires power.

## Pre-Heat Condition

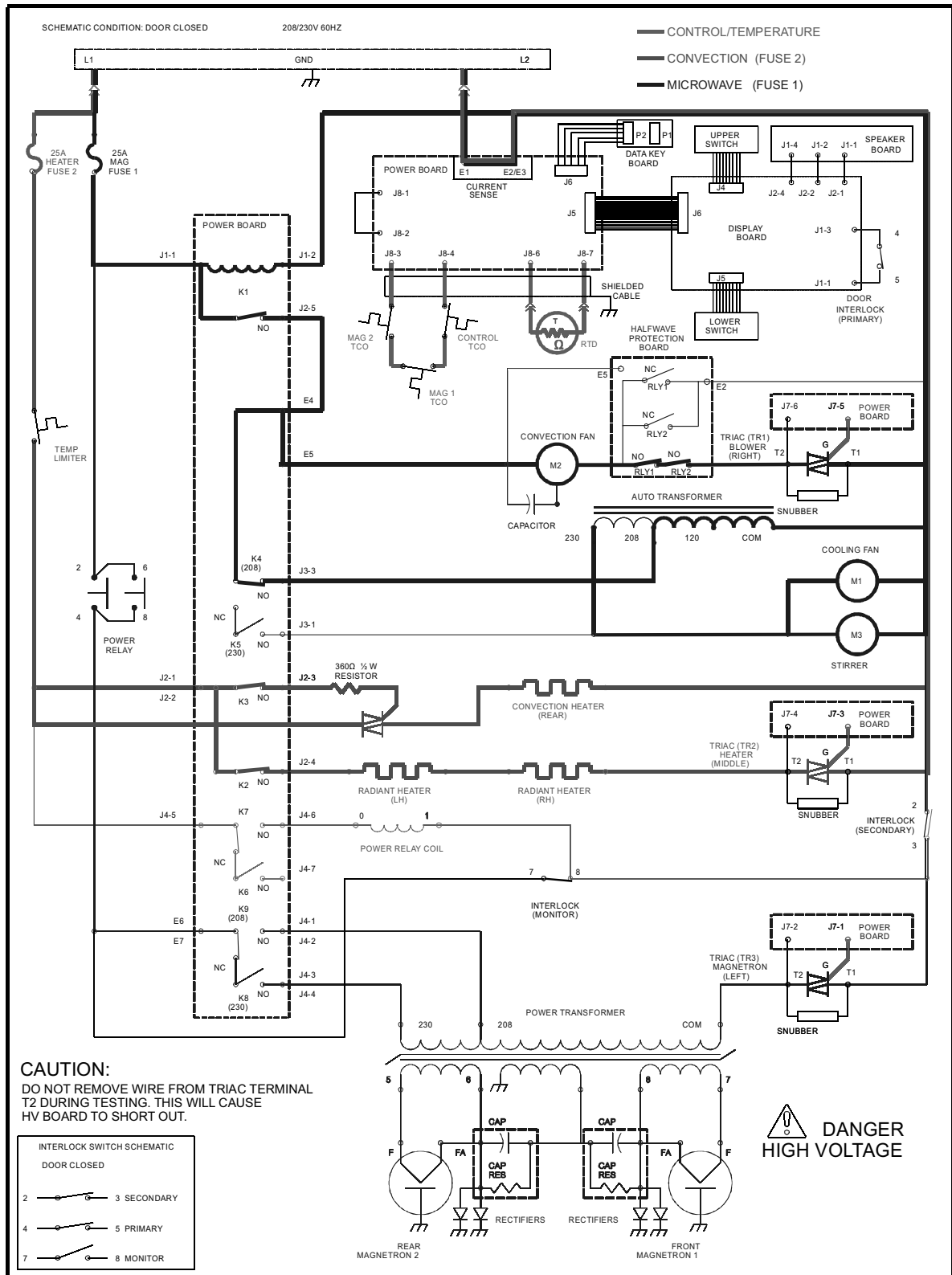

# 60 Hz Troubleshooting Procedures



**WARNING**

To avoid risk of electrical shock, personal injury or death; disconnect power to oven and discharge capacitor before servicing, unless testing requires power.

## Cook Condition

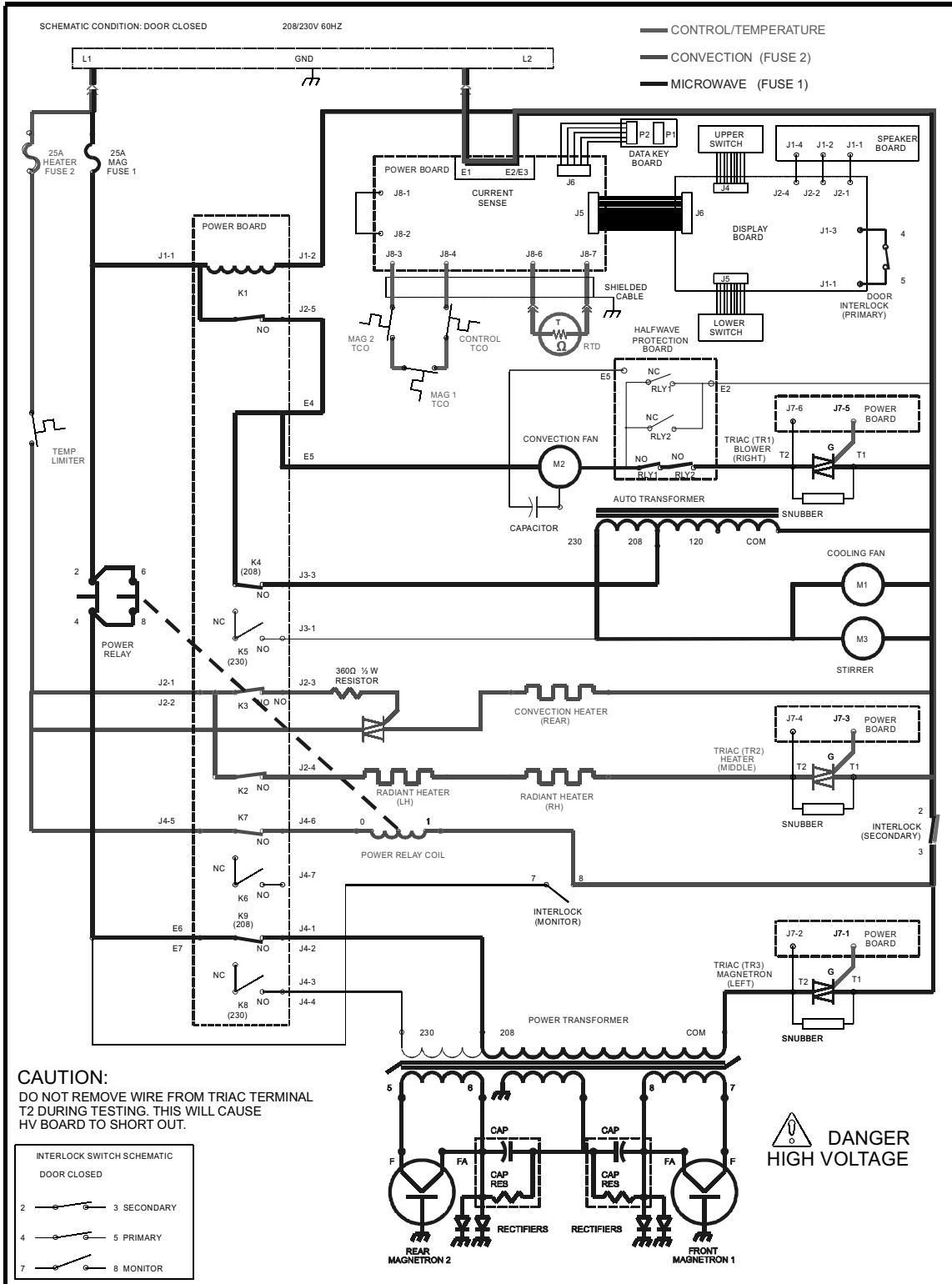

# 50 Hz Troubleshooting Procedures



## WARNING

To avoid risk of electrical shock, personal injury or death; disconnect power to oven and discharge capacitor before servicing, unless testing requires power.

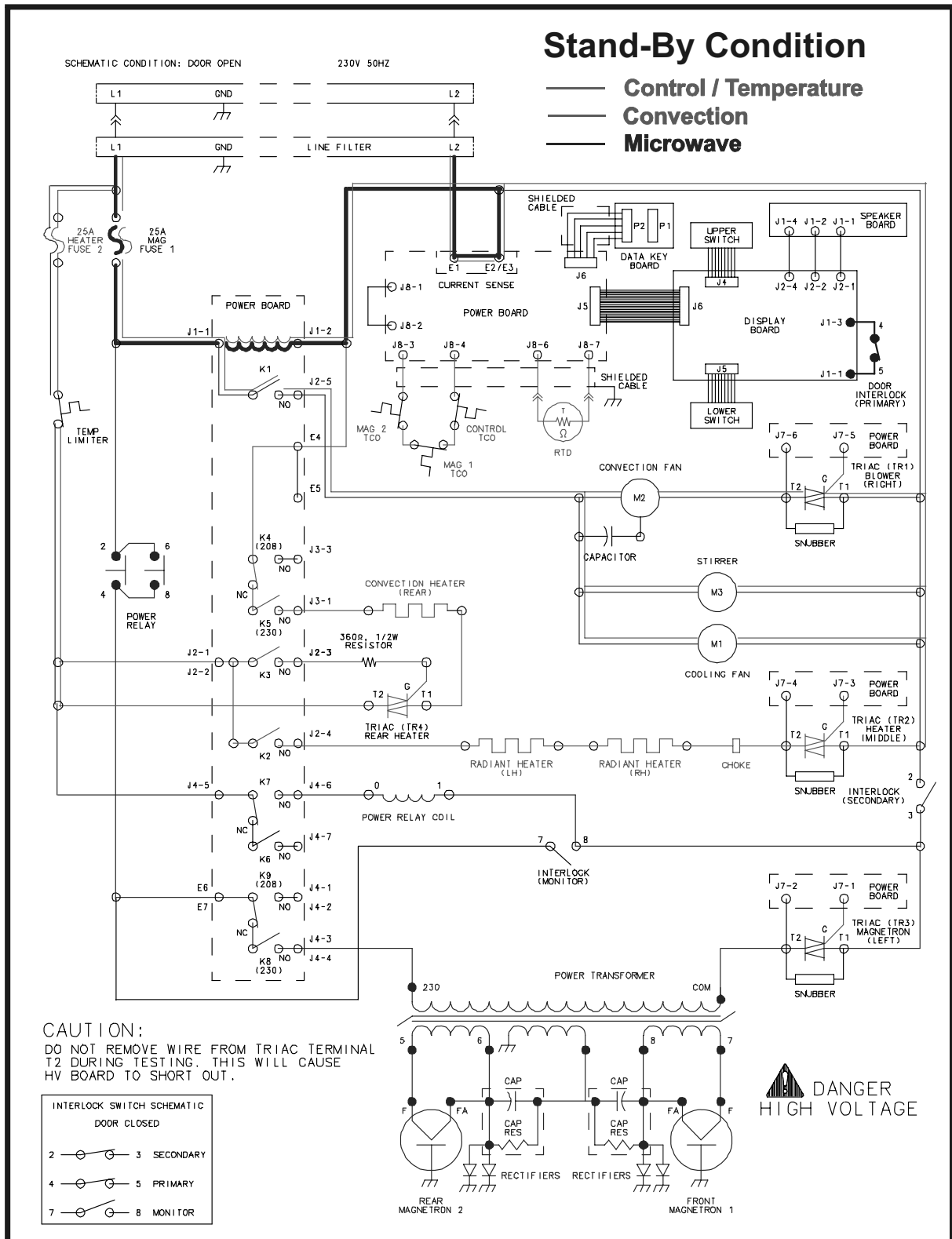

# 50 Hz Troubleshooting Procedures



**WARNING**

To avoid risk of electrical shock, personal injury or death; disconnect power to oven and discharge capacitor before servicing, unless testing requires power.

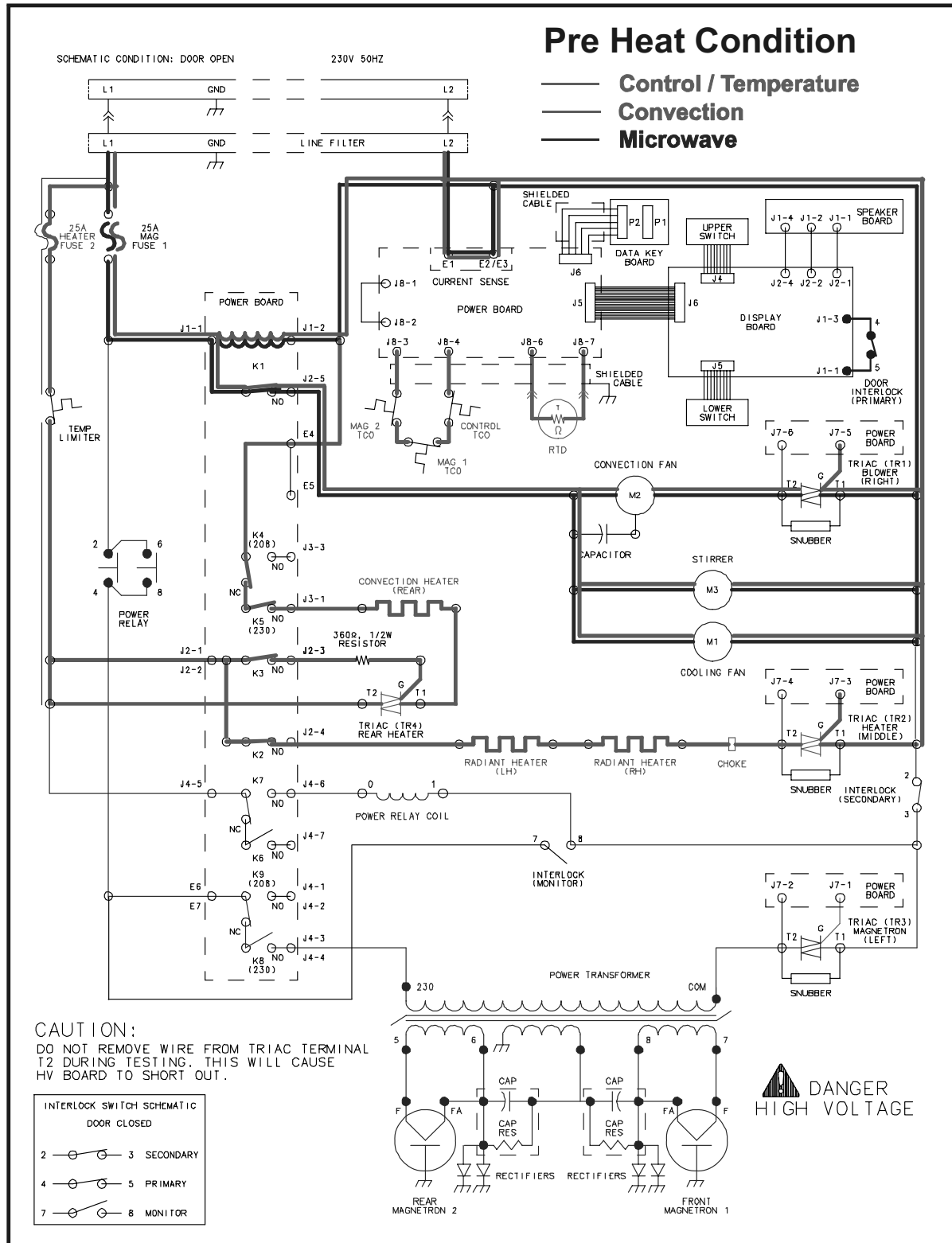

# 50 Hz Troubleshooting Procedures



**WARNING**

To avoid risk of electrical shock, personal injury or death; disconnect power to oven and discharge capacitor before servicing, unless testing requires power.

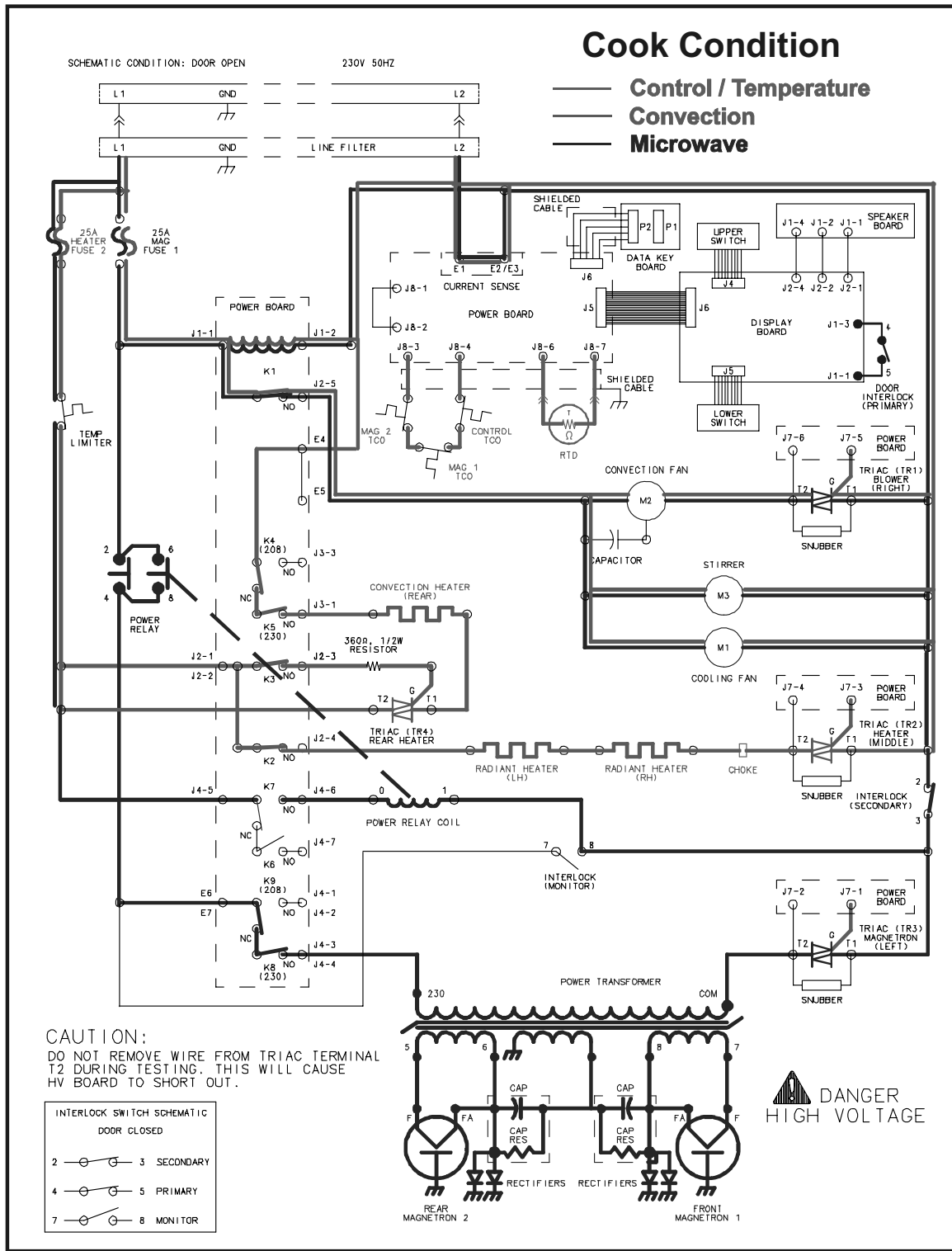









# Component Testing Procedures

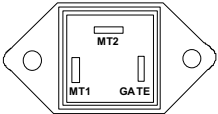
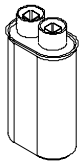

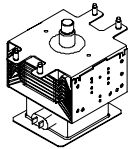
## WARNING

To avoid risk of electrical shock, personal injury or death; disconnect power to oven and discharge capacitor before servicing, unless testing requires power.

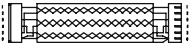
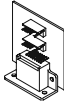
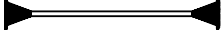

Illustration	Component	Test	Results
	Thermal cutout	Disconnect all wires from TCO. Measure resistance across terminals. Control TCO .....  Magnetron TCO.....	Closed at 113° C (235° F) and open at 66° C (150° F). Open at 149° C (300° F) and closed at 125° C (257° F).
	Diode	<b>Discharge Capacitor</b>  Remove diode lead from capacitor and connect ohmmeter. Reverse leads for second test.	Infinite resistance should be measured in one direction and 50KΩ or more in the opposite direction. <b>NOTE:</b> Ohmmeter must contain a battery of 6 volts minimum.
	Triac	Disconnect wires to triac. Measure resistance from: MT1 to MT2 ..... MT1 to Gate .....  MT2 to Gate ..... All terminals to ground.....	<b>Caution - Do not operate oven with wire to terminal MT2 removed.</b> Infinite. Approximately 15 Ω, then reverse meter leads 30 Ω. Infinite. Infinite.
Triac 1 (top) is for front element. Triac 2 (middle) is for rear element.		Measure voltage from MT1 to Gate .....	0.8 VAC when energized. If no voltage, check H.V. board and wiring.
	Capacitor	<b>Discharge Capacitor</b> Remove wires from capacitor terminals and connect ohmmeter, set on highest resistance scale to terminals.  Also check between each terminal and capacitor case.....	<b>Between Terminals:</b> Meter should momentarily deflect towards zero then return to over 5 MΩ. If no deflection occurs, or if continuous deflection occurs, replace capacitor. <b>Terminal to Case:</b> Infinite resistance.
	Snubber assembly	Disconnect wires to snubber.  Measure resistance across terminals.....	Infinite.
	Magnetron	<b>Discharge Capacitor</b>  Remove wires from magnetron and connect ohmmeter to terminals. Also check between each terminal and ground.	<b>Between Terminals:</b> Less than 1 Ω. Each terminal to ground measures Infinite resistance. <b>NOTE:</b> This test is not conclusive. If oven does not heat and all other components test good, replace the magnetron and retest.
<b>60 HZ Models only</b> 	Microwave blower motor	Remove all wires from motor.  Measure resistance across coil.....	Approximately 26 Ω.
<b>50 HZ Models only</b> 	Microwave blower motor	Remove all wires from motor.  Measure resistance across coil.....	Approximately 33.5 Ω.
	Stirrer motor	Remove all wires from terminals. Measure resistance from terminal to terminal.....	Approximately 29K Ω.
	EZCard Harness	Test continuity of wires .....	Continuity.
	EZCard Board	Insert EZCard to determine if unit can be programmed .....	If unit can not be programmed, verify EZCard harness is good. If harness is good, replace EZCard Board.
	HV board to display module wiring harness	Test resistance of wires .....	Continuity.



# Component Testing Procedures

## ⚠ WARNING

To avoid risk of electrical shock, personal injury or death; disconnect power to oven and discharge capacitor before servicing, unless testing requires power.

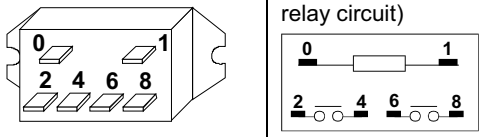
Illustration	Component	Test	Results
	Cavity heating element	Disconnect wires from terminals. Measure resistance across heating element (900 W) .....	Approx. 12 Ω.
	Resistance thermal device (RTD)	<b>Temperature</b> 0° C (32° F) ..... 230° C or 250° C (450° F or 475° F).....	<b>Resistance</b> Approx. 1000 Ω. Approx. 1850 to 1900 Ω.
	Relay (contains diode in relay circuit)	Measure resistance from: Terminal 0 to terminal 1 (coil) ..... Measure voltage from: Terminal 0 to Terminal 1 (coil).....	Approx. 6 to 7 MΩ.  230 VAC with oven in microwave <b>COOK</b> mode. <b>NOTE:</b> Analog meter is recommended for measurement.

**HIDDEN PAD** THEN **TEMP ENTRY** → Press Hidden Pad and Time Entry Pad = Displays current oven temperature (for 3 seconds) as sensed by RTD.

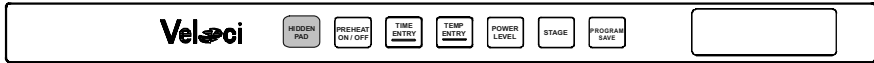
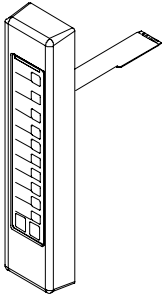
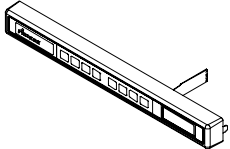
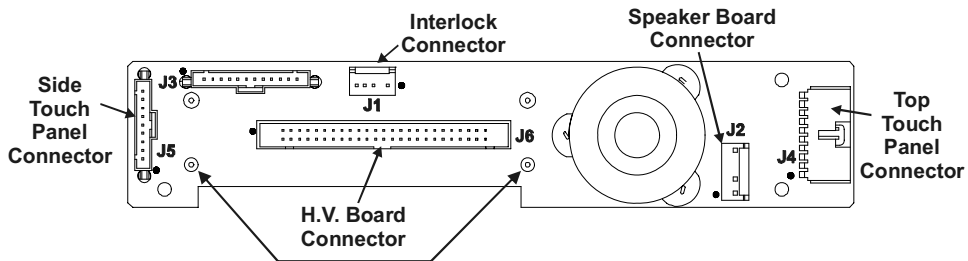

Illustration	Component	Test	Pad	Trace (measure both)	Measurement
	Side touch panel	Continuity is 100 Ω and below.	1 2 3 4 5 6 7 8 9 0 Start Stop/Reset	3 & 1, 5 & 1 3 & 1, 6 & 1 3 & 1, 7 & 1 3 & 1, 8 & 1 3 & 1, 9 & 1 4 & 1, 5 & 1 4 & 1, 6 & 1 4 & 1, 7 & 1 4 & 1, 8 & 1 4 & 1, 9 & 1 5 & 1, 6 & 1 6 & 1, 9 & 1	Continuity Continuity Continuity Continuity Continuity Continuity Continuity Continuity Continuity Continuity Continuity Continuity
	Top touch panel	Continuity is 100 Ω and below.	Preheat Time Entry Power Level Stage Program Quantity Temperature Menu Hidden Pad	3 & 1, 4 & 1 5 & 1, 7 & 1 5 & 1, 8 & 1 5 & 1, 9 & 1 6 & 1, 7 & 1 6 & 1, 8 & 1 7 & 1, 8 & 1 7 & 1, 9 & 1 8 & 1, 9 & 1	Continuity Continuity Continuity Continuity Continuity Continuity Continuity Continuity Continuity

### Display Board



3.5 VAC when oven is connected to power supply.

If voltage is present but display does not work, replace display board.

If voltage is not present, check wire harness connections and H.V. board.

# Component Testing Procedures



## WARNING

To avoid risk of electrical shock, personal injury or death; disconnect power to oven and discharge capacitor before servicing, unless testing requires power.

### H.V. Board

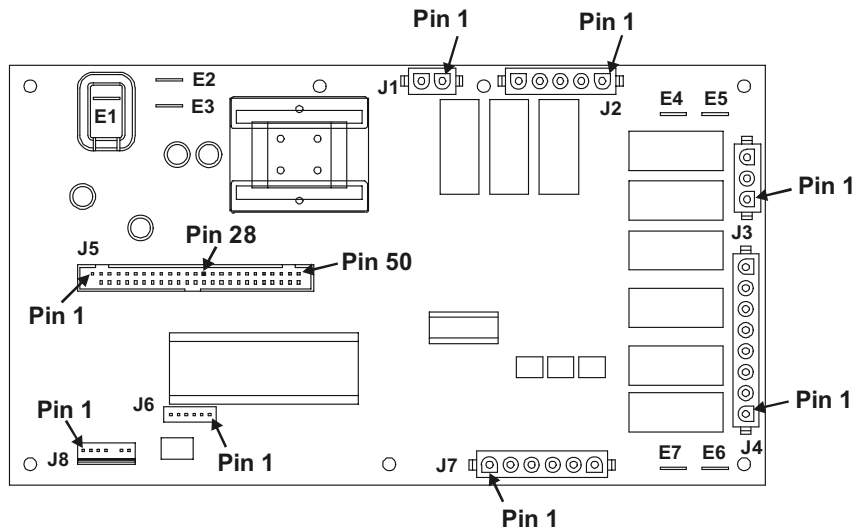

In straight convection mode, both elements operate simultaneously.

In combination mode, the rear element will operate simultaneously with either the microwave or front element.

Function	Test Set-Up	Meter Setting	Probe Placement	Results
Input to H.V. board	At H.V. board	Volts	J1 pin 1 (Black wire) & J1 pin 2 (Red wire)	Line voltage
Output to display board	Disconnect J5 connector	Volts	J5 pin 28 & J5 pin 50	- 24 VDC

**NOTE:** For the following test, place oven in Service Test Mode (see page 23).

Relay	Function	Meter Setting	Probe Placement	Results
K1	Cooling & Conv fan	Volts	E2 (Red wire) & E4 (Black wire)	Test mode pad 1 off – No voltage Test mode pad 1 on – Voltage
K2	Heater Top RH & LH	Volts	E2 (Red wire) & Back terminal on Heating Element (Hinge Side) (Violet wire)	Test mode pad 2 off – No voltage Test mode pad 2 on – Voltage
K3	Convection heater	Volts	E2 (Red wire) & Convection Heating Element (Gray wire)	Test mode pad 4 off – No voltage Test mode pad 4 on – Voltage
K5	Cooling & Conv fan	Volts	E2 (Red wire) & Auto Transformer (Orange wire 230 terminal)	Test mode pad 1 off – No voltage Test mode pad 1 on – Voltage
K7	Microwave	Volts	E2 (Red wire) & Power Relay (Orange wire terminal 0)	Test mode pad 3 off – No voltage Test mode pad 3 on – Voltage
K8	Microwave	Volts	E2 (Red wire) & Transformer (Red wire 230 terminal)	Test mode pad 3 off – No voltage Test mode pad 3 on – Voltage
K4	Cooling & Conv fan	Volts	E2 (Red wire) & Auto Transformer (Yellow wire 208 V terminal)	Test mode pad 1 off – No voltage Test mode pad 1 on – Voltage
K9	Microwave	Volts	E2 (Red wire) & Transformer (Black wire 208 terminal)	Test mode pad 3 off – No voltage Test mode pad 3 on – Voltage

# Power Test Procedures



To avoid risk of electrical shock, personal injury or death; disconnect power to oven and discharge capacitor before servicing, unless testing requires power.

All Amana and Menumaster microwave oven power outputs are rated using the IEC705 standards. Using the IEC705 test method requires precision measurements and equipment that is not practical to be performed in the field. Using the test shown below will indicate if the oven performance is satisfactory.

## Test equipment required:

- 1000 ml test container and thermometer (Amana power test kit R0157397 Fahrenheit / Menumaster power test kit M95D5 Celsius).

## Important Notes:

- Low line voltage will cause low temperature rise / power output.
- Ovens must be on a dedicated circuit, properly grounded, and polarized. Other equipment on the same circuit may cause a low temperature rise / power output.
- This test and results are not a true IEC705 test procedures and are only intended to provide servicers with an easy means of determining if the microwave oven cooking output is correct.
- **Oven must be cold, before performing this test.**

## Procedure

1. Fill the test container to the 1000 ml line with cool tap water.

**NOTE:** Water temperature should be approximately 60° F / 16° C

2. Using the thermometer, stir water for five to ten seconds; measure, and record the temperature (T1).
3. Place test container of water in the center of oven cavity using the lowest rack position and close door.
4. Heat the water for a 33-second full power cycle by using the microwave service test procedure.
  - a. Oven must be in STANDBY mode.
  - b. Close the door.
  - c. Press Hidden Pad, 1, 3, 5, 7, 9.
  - d. Press 3 to activate microwave service mode.
  - e. Open the door after 33 seconds have elapsed.
5. At end of the cycle, remove test container. Using the thermometer, stir water for five to ten seconds and record temperature (T2).
6. Subtract the starting water temperature (T1), from the ending water temperature (T2) to obtain the temperature rise ( $\Delta T$ ).
7. If the temperature rise ( $\Delta T$ ) meets or exceeds the minimum, the test is complete. If the temperature rise ( $\Delta T$ ) fails to meet the minimum temperature rise, test the line voltage to verify it is correct. Then repeat steps 1-6 making sure to change the water. If the temperature rise ( $\Delta T$ ) fails to meet the minimum temperature rise again, the oven will require service.

### Minimum Temperature Rise at Thirty -Three (33) Seconds Run Time

$\Delta T$ (°F)	Cooking Power Output	$\Delta T$ (°C)	Cooking Power Output
20.....	2000	11.....	2000

# Convection Temperature Test and Calibration



## WARNING

To avoid risk of electrical shock, personal injury or death; disconnect power to oven and discharge capacitor before servicing, unless testing requires power.

### Convection Temperature Test

**NOTE:** It is absolutely necessary to own and use a thermocouple type oven tester to accurately measure oven temperature. No other type of thermometer can take its place.

**NOTE:** Before testing an oven to check calibration, inspect the RTD for proper mounting.

1. Place one wire rack in center position. Remove any other racks and utensils.
2. Clip thermocouple to the center rack and run lead outside oven door, or wrap thermocouple around rack and have the tip of thermocouple extend upward towards top of cavity approximately 1 inch.
3. Press **PREHEAT ON/OFF** pad.
4. Press **PROGRAM SAVE** pad.
5. Press **TEMP** pad.
6. Enter 230° C (450° F).
7. Allow oven to cycle one time.
8. Record high and low peaks from next two cycles.

**NOTE:** Display **does not** indicate if heating elements are on or off.

#### Fahrenheit Example:

	<u>LOW</u>	<u>HIGH</u>
Cycle 1	440° F	460° F
Cycle 2	<u>439° F</u>	<u>461° F</u>
	879° F +	921° F = 1800° F
	1800° F / 4 = 450° F average temperature	

#### Celsius Example:

	<u>LOW</u>	<u>HIGH</u>
Cycle 1	230° C	240° C
Cycle 2	<u>230° C</u>	<u>240° C</u>
	460° C +	480° C = 940° C
	940° C / 4 = 230° C average temperature	

If the average temperature is too high or too low the oven temperature offset needs to be calibrated.

### Convection Temperature Calibration

**NOTE:** It is normal for the average oven temperature to vary from the oven setting by as much as 14° C (25° F). Difference will not effect cooking since recipes are written with this difference in mind.

#### Calibration

**NOTE:** Door must be closed and unit must be in STANDBY mode.

1. Press **HIDDEN PAD**.
2. Press pads **1,3,5,7, 9**.
3. Press **"0"** pad.



**NOTE:** Display will show the current offset setting.

4. Press the **"0"** pad to change the offset.

#### Fahrenheit

**NOTE:** Offset temperature range is +40° F to -40° F and advances in 2° and 3° increments.

#### Celsius

**NOTE:** Offset temperature range is +22° C to -22° C and advances in 1° and 2° increments.

5. Press **STOP/RESET** pad to save offset changes.

**NOTE:** Retest the oven after any offset changes are made.

#### Fahrenheit Example:

- Oven temperature is set for 450° F.
- Average of temperature test is 475° F.
- Offset setting must be reduced by 25° F.
- If offset is shown as 10°F, press the **"0"** pad. until -15 is shown in the display (10 – 25 = -15).

#### Celsius Example:

- Oven temperature is set for 230° C.
- Average of temperature test is 240° C.
- Offset setting must be reduced by 10° C.
- If offset is shown as 5°C, press the **"0"** pad until -5 is shown in the display (5 – 10 = -5).

# Display Diagnostics



## WARNING

To avoid risk of electrical shock, personal injury or death; disconnect power to oven and discharge capacitor before servicing, unless testing requires power.



## CAUTION

All repairs as described in this troubleshooting section are to be performed only after the caution procedures one through eight listed below have been followed.

1. Check grounding before checking for possible causes.
2. Be careful of the high voltage circuit.
3. Discharge high voltage capacitor.
4. When checking the continuity of the switches or the high voltage transformer, disconnect one lead wire from these parts and then check continuity with the AC plug removed. To do otherwise may result in a false reading or damage to your meter.
5. Do not touch any parts of the circuitry on the P.C. Board circuit since static electric discharge may damage this control panel. Always touch yourself to ground while working on this panel to discharge any static charge in your body.
6. 208/230 VAC is present in the high voltage circuit board, power relay and primary circuit of low voltage transformer.
7. When troubleshooting, be cautious of possible electrical hazard.
8. When testing convection operation, convection fan may start at any time or if oven is hot.

## Error Codes

During operation, the display may show the following service codes:

**NOTE:** Before scheduling service for any error codes, instruct customer to unplug oven for 1 minute, reconnect power, and retest. If unit operates properly, no service call is required.

Display	Description	Corrective Action
<b>Err1</b>	Checksum failure	Replace Power Board
<b>Err2</b>	Hardware problem	Replace Power Board Replace Keyboard
<b>Err3</b>	Hardware problem	Replace Power Board Replace Keyboard
<b>Err4</b>	Wrong jumper setting	Check cable to Power Board
<b>Err5</b>	Shorted keypad	<b>NOTE:</b> If Touch Panel is pressed for more than 30 seconds, error code <b>Err5</b> displays. 1. Disconnect oven from power supply. 2. Disconnect side touch panel connector from display board (J5). 3. Reconnect oven to power supply. 4. If <b>Err5</b> reappears after 30 seconds, replace top touch panel. 5. If <b>Err5</b> does not reappear after 30 seconds, replace side touch panel.
<b>Err6</b>	Options scrambled	Replace Power Board
<b>Err7</b>	Problem with RTD	Additional info displayed
<b>Err7<sub>0</sub></b>	<b>0</b> – Uncalibrated	Replace Power Board
<b>Err7<sub>1</sub></b>	<b>1</b> – Shorted	Check RTD, connections and J8 cable on HV Board
<b>Err7<sub>2</sub></b>	<b>2</b> – Open	Check RTD and connections
<b>Err8</b>	Over temperature	Inform Customer to press STOP/RESET Twice Check Triac (TR2) Check that Relay (K3) is cycling (Convection HTR)
<b>Err9</b>	Over temperature Current < 2 amps	Check Thermal Limiter Check Triac (TR2) Check that Relay (K3) is cycling (Convection HTR)
<b>HOT</b>	Over temperature (During Cook Time)	See Important Notes Section Check Magnetron TCO
<b>HOT</b>	Remains in the display	Check harness from H.V. Board J8 to TCOs: <b>Short together J8-3 to J8-4:</b> If <b>HOT</b> error clears, check or replace cable. If <b>HOT</b> error remains, replace H.V. Board.

# Service Test







**⚠ WARNING**

To avoid risk of electrical shock, personal injury or death; disconnect power to oven and discharge capacitor before servicing, unless testing requires power.

# Service Test

Putting the oven into Service Test allows you to individually diagnose individual components of the oven, as well as access the Tube Hours and Door Cycles the oven has experienced.











## Entering Service Test

Step	Action	Display	Description
1			Turn OFF oven by Pressing <b>PREHEAT ON/OFF</b>
2	 		Press <b>HIDDEN PAD</b>
3		<p><b>STG</b> indicates input power is 230 VAC.</p> <p><b>QTY</b> indicates input power is 50 Hz.</p> 	Press <b>1, 3, 5, 7, 9 PADS</b>

# Service Functions

## **WARNING**

To avoid risk of electrical shock, personal injury or death; disconnect power to oven and discharge capacitor before servicing, unless testing requires power.

Action	Display	Description
	<p>For Pads 1 – 3, Display shows amps being drawn.</p> <p>Appears if plugged into 230 V</p>  <p>Counter    1 = ON 0 = OFF    AMPS    Pad #</p>	<p>Press pad once to turn on. Press again to turn off.</p> <p>On Pads 2 &amp; 3, counter will count up to 62 seconds, then output will turn off.</p>
 1		<p><b>Convection Fan</b> (Internal Cooling Fan runs also to prevent unit from overheating)</p>
 2		<p><b>Radiant Heater</b> (Convection Fan runs also to prevent unit from overheating)</p>
 3		<p><b>Magnetrons</b> (Internal Cooling Fan runs also to prevent magnetrons from overheating)</p>
 4		<p><b>Convection Heater</b> (Convection Fan runs also to prevent unit from overheating)</p>
 5		<p><b>Internal Cooling Fan</b> (Convection Fan runs also to prevent unit from overheating)</p>

# Service Functions



## WARNING

To avoid risk of electrical shock, personal injury or death; disconnect power to oven and discharge capacitor before servicing, unless testing requires power.

Action	Display	Description
		<p><b>Mag Hours</b> (241 shown in this example)</p>
		<p><b>Door Cycles</b> (13,895 shown in this example)</p>
		<p>Displays OFFSET temperature</p>

# Disassembly



## WARNING

To avoid the risk of electrical shock, personal injury, or death, disconnect power to oven and discharge capacitors before following any disassembly procedure.

### Door Handle

Remove door handle by removing plastic plugs to gain access to set screws. Loosen set screws using a (3/32 inch allen screws), one located to the left of the door handle and one located on the bottom of the door handle.

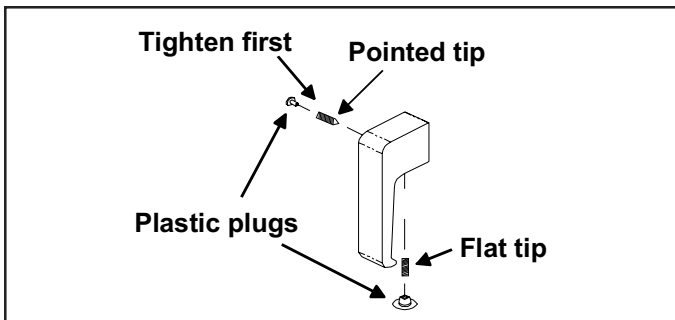

**NOTE:** When replacing door handle, tighten side set screw first and apply LOCTITE.

**NOTE:** If set screws are removed, the set screw with the flat end must be used in the bottom of the door handle.

### Magnetic Door Stop

1. Open the oven door.
2. Remove screws securing magnetic door stop to door hinge.
3. Reverse procedure to reassemble.

### Outer Door

1. Remove door handle, see "Door Handle" procedure.
2. Remove plastic plugs covering screws with a thin flat blade screwdriver.
3. Remove thumb screws securing door heat shield to outer door.
4. Remove crows foot screws, securing outer door to inner door assembly.
5. Remove outer door from inner door assembly.
6. Reverse procedure to reassemble.

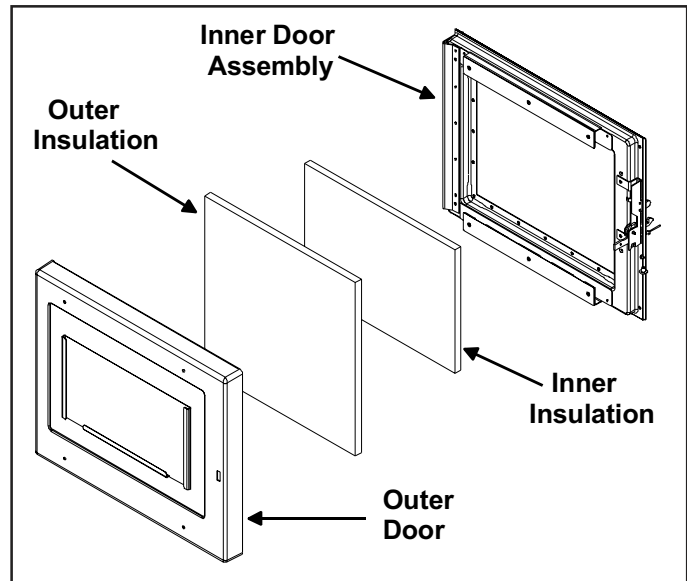

### Inner Door Assembly

1. Remove outer door, see "Outer Door" procedure.
2. Remove insulation pads from inner door assembly.
3. Remove screws securing inner door assembly to hinge.
4. Reverse procedure to reassemble.

### Hinge

1. Remove outer case, see "Outer Case" procedure.
2. Open oven door and remove screws securing magnetic door guard from door hinge.
3. Remove outer door, see "Outer Door" procedure.
4. Remove hinge mounting screws from hinge (five on front, four on side).

**NOTE:** Discard foam gasket on side of hinge.

5. When reinstalling hinge mounting screws, keep the side screws loose and tighten the front screws, close door, press door against oven on the hinge side and tighten side hinge mounting screws in the sequence shown below.

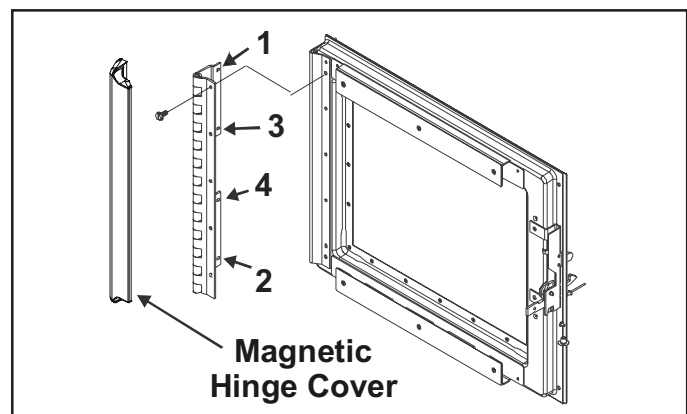

# Disassembly



## WARNING

To avoid the risk of electrical shock, personal injury, or death, disconnect power to oven and discharge capacitors before following any disassembly procedure.

### Outer Case

1. Remove screws securing outer flue, located on the back of the unit.
2. Remove screws securing outer case to chassis, see illustration below.
3. Slide outer case back and lift off.
4. Reverse procedure to reassemble.

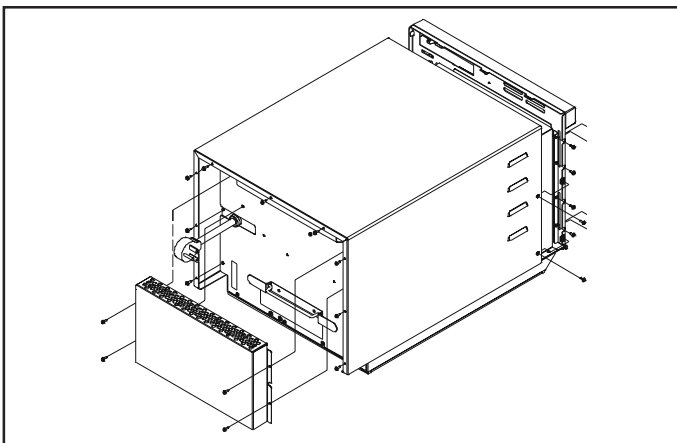

### Back Panel

1. Remove outer case, see "Outer Case" procedure.
2. Remove screws securing inner flue, located on the back of the unit.
3. Remove screws securing back panel.
4. Reverse procedure to reassemble.

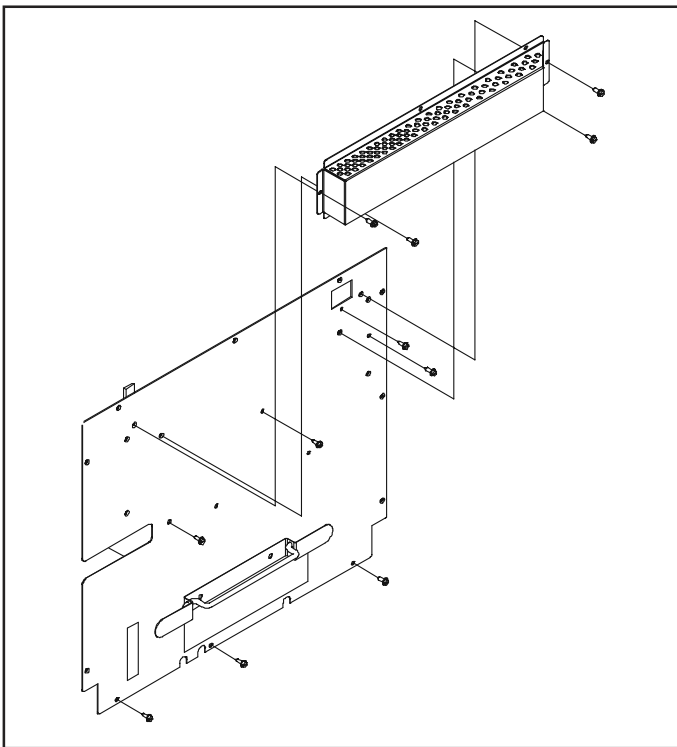

### Interlock Switch Module

1. See "Component Location" Figure 2, for location.
2. Remove outer case, see "Outer Case" procedure.
3. Disconnect wiring from interlock switch assembly.
4. Remove mounting screws securing interlock switch.
5. When replacing assembly, all wires must be connected before operating oven.

**NOTE:** When the line fuse is blown, **interlock switch module** must be replaced.

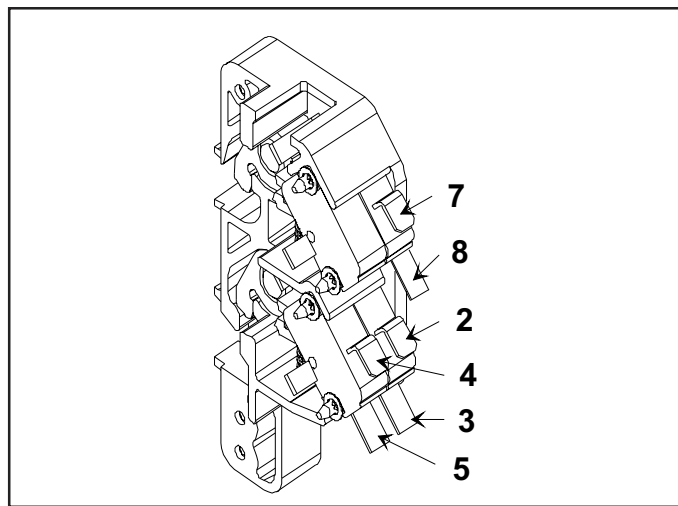

### Adjustment

1. To adjust interlock switch assembly, close door.
2. Loosen bottom and top screw on the interlock switch assembly, allowing switch assembly to move in or out.
3. With door closed, push forward on interlock assembly to engage door latch. Then pull back on interlock assembly until door is "snug" against front oven cavity and tighten bottom screw first, then top screw.
4. Door will remain latched when proper adjustment is made.

**NOTE:** If door is not properly adjusted display will indicate *DOOR* when the door is closed.

### Stirrer Motor and Antenna Gears

1. Unplug oven and place unit on its side.
2. Removing screw securing bottom access panel.
3. Remove screws securing stirrer motor to chassis.
4. Remove retainer clip securing antenna gear to antenna shaft.
5. Reverse procedure to reassemble.

# Disassembly



## WARNING

To avoid the risk of electrical shock, personal injury, or death, disconnect power to oven and discharge capacitors before following any disassembly procedure.

### RTD (Resistance Thermal Device)

1. See "Component Location" Figure 3, page 53.
2. Remove outer case, see "Outer Case" procedure.
3. Disconnect RTD harness connector.
4. Remove mounting screws securing RTD to plenum box, located inside oven.
5. Remove RTD by lifting from top of the oven.
6. Reverse procedure to reassemble.

### Top Touch Panel Assembly

1. See "Component Location" Figure 1, page 32.
2. Remove outer case, see "Outer Case" procedure.
3. Disconnect all wire connectors and ribbon cables from display board.
4. Remove screws securing top touch panel to unit.
5. Remove screws securing display board to top touch panel assembly.
6. Reverse procedure to reassemble.

### Side Touch Panel Assembly

1. See "Component Location" Figure 1, page 32.
2. Remove outer case, see "Outer Case" procedure.
3. Remove ribbon cable from display board.
4. Remove mounting screws securing side touch panel to unit.
5. Reverse procedure to reassemble.

### Display Module

1. See "Component Location" Figure 1.
2. Remove top touch panel, see "Top Touch Panel Assembly" procedure.
3. Remove screws securing display module to top touch panel.
4. Reverse procedure to reassemble.

### Heating Elements (oven top)

1. Remove outer case, see "Outer Case" procedure.
2. Remove Plenum Plate. See "Component Location" Figure 2, page 32.
3. Remove screws securing top of heating element clamp, located inside the oven cavity.
4. Remove screw securing access plate (see figure 6) to insulation retainer.
5. Remove access plate (figure 2, page 32) and insulation from unit to gain access to calrod block.
6. Disconnect wire terminals from calrod at terminals.
7. Loosen set screw enough to separate calrod block from around heating element.
8. Slowly maneuver heating element from inside the oven cavity to remove.
9. Reverse procedure to reassemble.

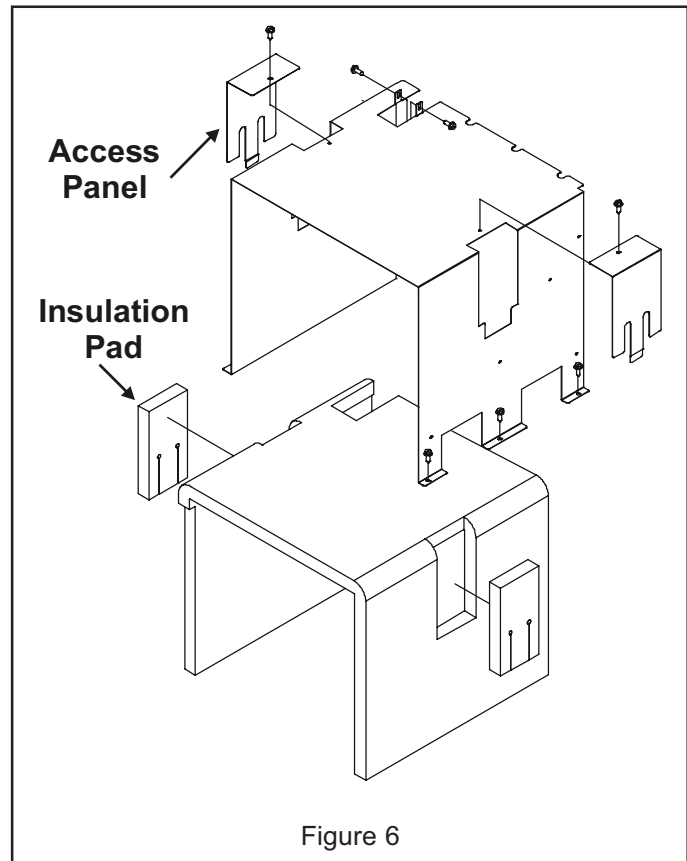

Figure 6

**NOTE:** When reassembling unit verify insulation is properly placed around the element(s), before securing access panel.

### Inlet Duct Assembly

1. Remove back panel, figure 3, page 33, and see "Back Panel" procedure.
2. Disconnect and label wire terminals from convection fan motor.
3. Disconnect connector plug, remove from inlet duct.
4. Slide inlet duct assembly away from unit to remove.
5. Reverse procedure to reassemble.

### Halfwave Board (60 Hz Models Only)

1. See figure 3, page 33 for location.
2. Disconnect wire terminals from halfwave board.
3. Release mounting clips securing board and remove board.
4. Reverse procedure to reassemble.

# Disassembly



## WARNING

To avoid the risk of electrical shock, personal injury, or death, disconnect power to oven and discharge capacitors before following any disassembly procedure.

### Control Board Assembly Bracket

1. Remove back panel, see "Back Panel" procedure (page 33).
2. Remove inlet duct assembly, see "Inlet Duct Assembly" procedure.
3. Disconnect wire harness from plastic clips.
4. Slide bracket towards the center of the unit.
5. Raise bracket up and pull outward towards the rear of unit to remove.
6. Reverse procedures to reassemble.

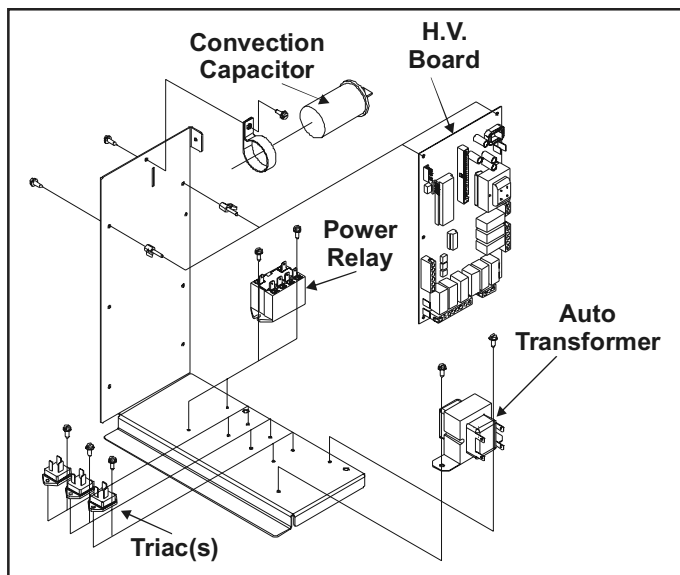

### Auto Transformer (60 Hz Models Only)

1. Remove back panel, see "Back Panel" procedure (page 33).
2. Disconnect and label wire terminals from auto transformer.
3. Remove screws securing auto transformer to power assembly bracket.
4. Reverse procedures to reassemble.

### Triacs (Figure 3, Page 33)

1. Remove back panel, see "Back Panel" procedure (page 33).
2. Disconnect and label wire terminals from selected triac.
3. Remove screws securing triac to power assembly bracket.
4. Reverse procedures to reassemble.

### Power Relay (Figure 3, Page 33)

1. Remove back panel, see "Back Panel" procedure.
2. Disconnect and label wire terminals from power relay.
3. Remove screws securing power relay to power assembly bracket.
4. Reverse procedures to reassemble.

### Convection Motor Capacitor (Fig 3, Page 33)

1. Remove outer case, see "Outer Case" procedure
2. Disconnect and label wire terminals from capacitor.
3. Remove screws securing capacitor bracket to power assembly bracket.
4. Reverse procedures to reassemble.

### High Voltage Circuit Board

1. See "Component Location" Figure 2, page 33.
2. Remove outer case, see "Outer Case" procedure.
3. Disconnect and label connectors and wire terminals from H.V. Board.
4. Release mounting clips securing board and remove board.
5. Reverse procedure to reassemble.

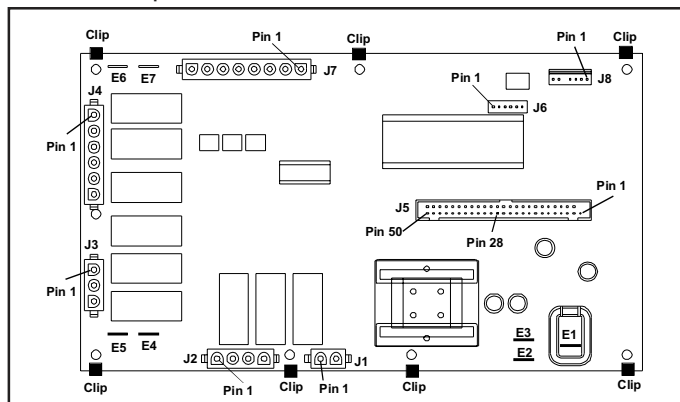

**NOTE:** When reassembling, verify cable connection with illustration of cable locations.

### Magnetron

1. See "Component Location" Figure 3, page 33.
2. Remove outer case, see "Outer Case" procedure.
3. Remove screws securing magnetron inlet cover and remove cover.
4. Remove screws securing waveguide duct.
5. Remove wire terminals from magnetron.
6. Remove allen screws securing magnetron thermal cutout bracket to magnetron.
7. Remove magnetron mounting nuts and remove front magnetron cover bracket.
8. Remove magnetron.
9. When replacing magnetron, verify wire mesh gasket is reinstalled properly.

**NOTE:** When reinstalling magnetron, slide air baffle inside magnetron before mounting magnetron in place.

**NOTE:** Place front magnetron cover bracket in place before securing magnetron.

# Disassembly



## WARNING

To avoid the risk of electrical shock, personal injury, or death, disconnect power to oven and discharge capacitors before following any disassembly procedure.

### Magnetron, Control, and Fan Thermal Cutouts (TCO)

1. See figures 4 and 5, page 34, for location.
2. Remove outer case, see "Outer Case" procedure.
3. Disconnect and label wire terminals from selected thermal cutout.
4. Remove screws securing thermal cutout.
5. Reverse procedure to reassemble thermal cutout.

### Blower Bracket Assembly

1. Remove back panel, see "Back Panel" procedure.
2. Disconnect and label wire terminals from blower motor.
3. Disconnect and label wire terminals from fuse block.
4. Disconnect L2 connector plug.
5. Remove screws securing blower bracket to exterior of oven cavity.
  - one located at the rear on the bottom of bracket
  - one located above the rear magnetron
6. Reverse procedure to reassemble.

### Microwave Blower Wheel and Motor

1. Remove blower bracket assembly, see "Blower Bracket Assembly" procedure, also see figure 7.
2. Remove screws securing blower assembly to bracket.
3. Loosen allen set screw securing blower wheel to motor shaft.
4. Remove blower wheel.
5. Remove screws securing motor to scroll.
6. Reverse procedure to reassemble.

**NOTE:** When reinstalling blower wheel, push blower wheel on shaft, tighten, and rotate to insure clearance between blower wheel, and blower housing.

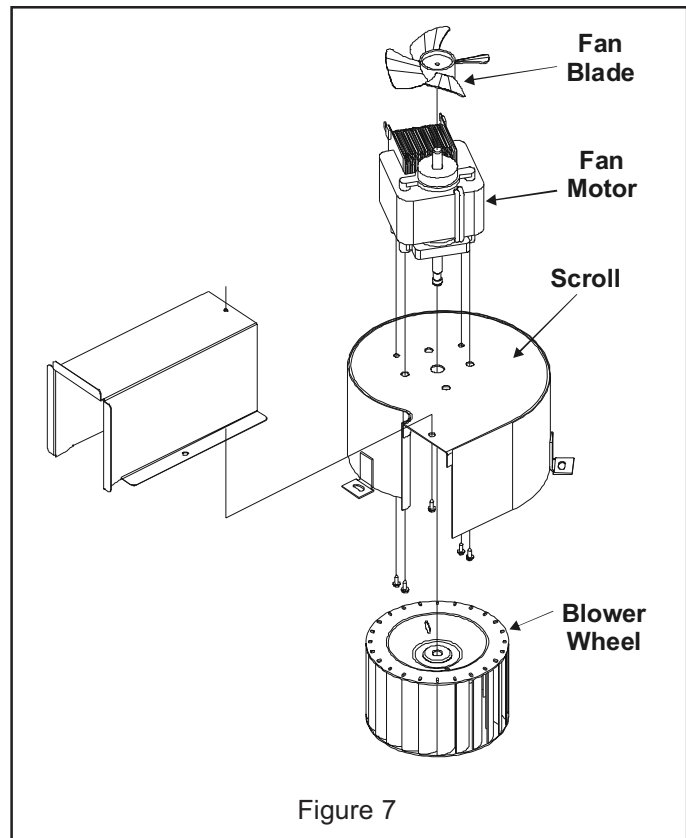

Figure 7

### Fan Blade

1. Pull blade off shaft.
2. When reinstalling blade, push blade on shaft and rotate to insure clearance between fan blade and motor mounting bolt.

### Transformer

1. See "Component Location" Figure 3, page 33.
2. Remove back panel, see "Back Panel" procedure.
3. Remove screws securing transformer to chassis.
4. Pry upward and pull back to release transformer from chassis.
5. Disconnect and label wire terminals from transformer.

**NOTE:** When placing transformer back into chassis. Front portion of transformer **must** slide into base pan tab.

6. Reverse procedure to reassemble

# Disassembly



## WARNING

To avoid the risk of electrical shock, personal injury, or death, disconnect power to oven and discharge capacitors before following any disassembly procedure.

### Capacitor / Diode

1. See figure 3, page 33 for location.
2. Remove outer case, see “Outer Case” procedure.
3. Discharge capacitor and remove wire terminals from capacitor.
4. Remove screws securing capacitor mounting bracket to oven chassis.
5. Loosen screws securing capacitor strap to capacitor.
6. Reverse procedure to reassemble.

### Convection Box

1. See “Component Location” Figure 5, page 34.
2. Remove back panel, see “Back Panel” procedure.
3. Remove inlet duct assembly, See “Inlet Duct Assembly” procedure.
4. Remove control board bracket assembly, see “Control Board Bracket Assembly” procedure.
5. Disconnect and label wire terminals from Heating Element, TCO, and Temperature Sensor.
6. Remove screws securing thermal limiter to convection box.
7. Remove screws securing convection box to plenum box.
8. Remove convection box from unit.
9. Remove bolt securing fan blade and pull fan blade off.
10. Remove screws securing convection motor to heater box.
11. Reverse procedure to reassemble.

### Convection Element

1. Remove convection box, see “Convection Box” procedure (located above).
2. Remove screws securing convection element to convection box.
3. Reverse procedure to reassemble.

**NOTE:** Center convection element around convection fan blade and spin fan blade to ensure it does not hit convection element.

### Thermal Limiter

1. See figure 3, page 33 for location.
2. Remove outer case, see “Outer Case” procedure.
3. Disconnect and label wire terminals from limiter.
4. Remove screws securing thermal limiter to convection box.
5. Loosen and remove RTV sealant securing limiter to plenum box.
6. Reverse procedure to reassemble.

**NOTE:** When reinstalling and securing limiter tube into plenum box. Lower limiter tube into the plenum box until 1/4” of limiter tube is left outside the plenum box and secure with RTV. Perform operational check on unit to ensure there is no air leakage around the limiter tube.

### Fuse

1. See “Component Location” Figure 2, for location.
2. Remove outer case.
3. Replace fuse and reassemble in reverse order.

### Power Cord

1. See “Component Location” Figure 3, for location.
2. Remove outer case and back panel.
3. Disconnect wiring.
4. Remove strain relief by compressing with pliers.
5. Remove power cord.
6. Reassemble power cord in reverse order.

### Line Filter (50 Hz Models Only)

1. See “Component Location” Figure 3, for location.
2. Remove outer case and back panel.
3. Disconnect wiring.
4. Remove power cord strain relief by compressing with pliers.
5. Remove power cord.
6. Remove screws securing line filter and remove.
7. Reassemble power cord in reverse order.

# Disassembly



## WARNING

To avoid the risk of electrical shock, personal injury, or death, disconnect power to oven and discharge capacitors before following any disassembly procedure.

### Component Location

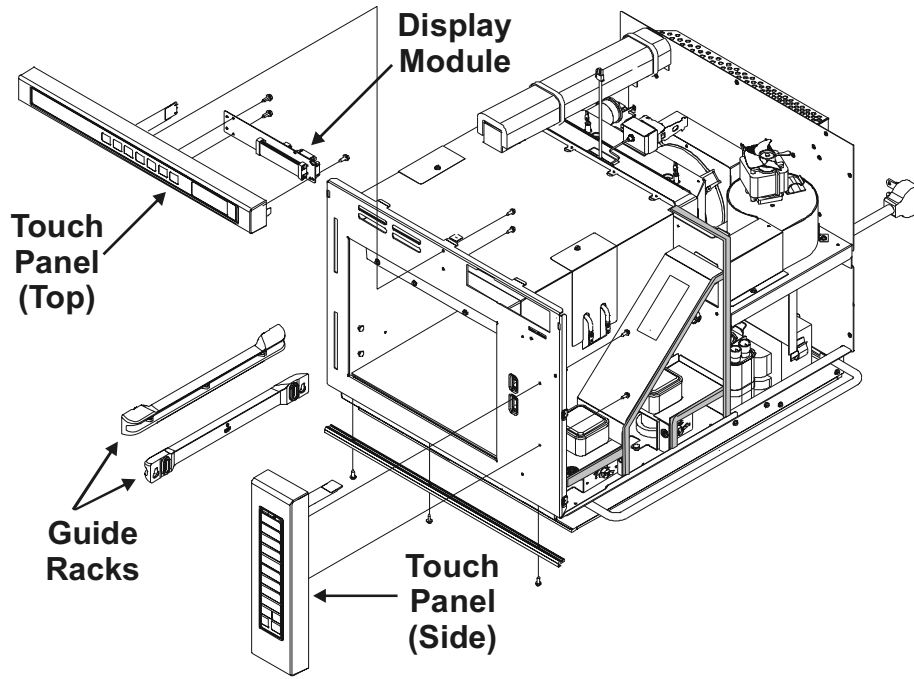

Figure 1  
Touch Panels/ Displays/Triacs

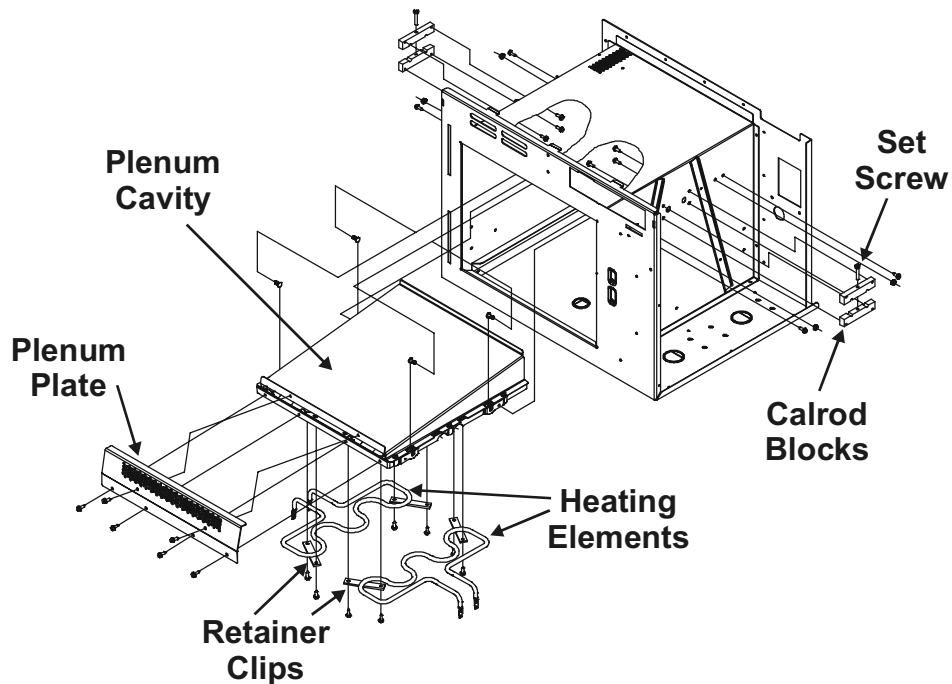

Figure 2  
Heating Element Assembly

# Disassembly



## WARNING

To avoid the risk of electrical shock, personal injury, or death, disconnect power to oven and discharge capacitors before following any disassembly procedure.

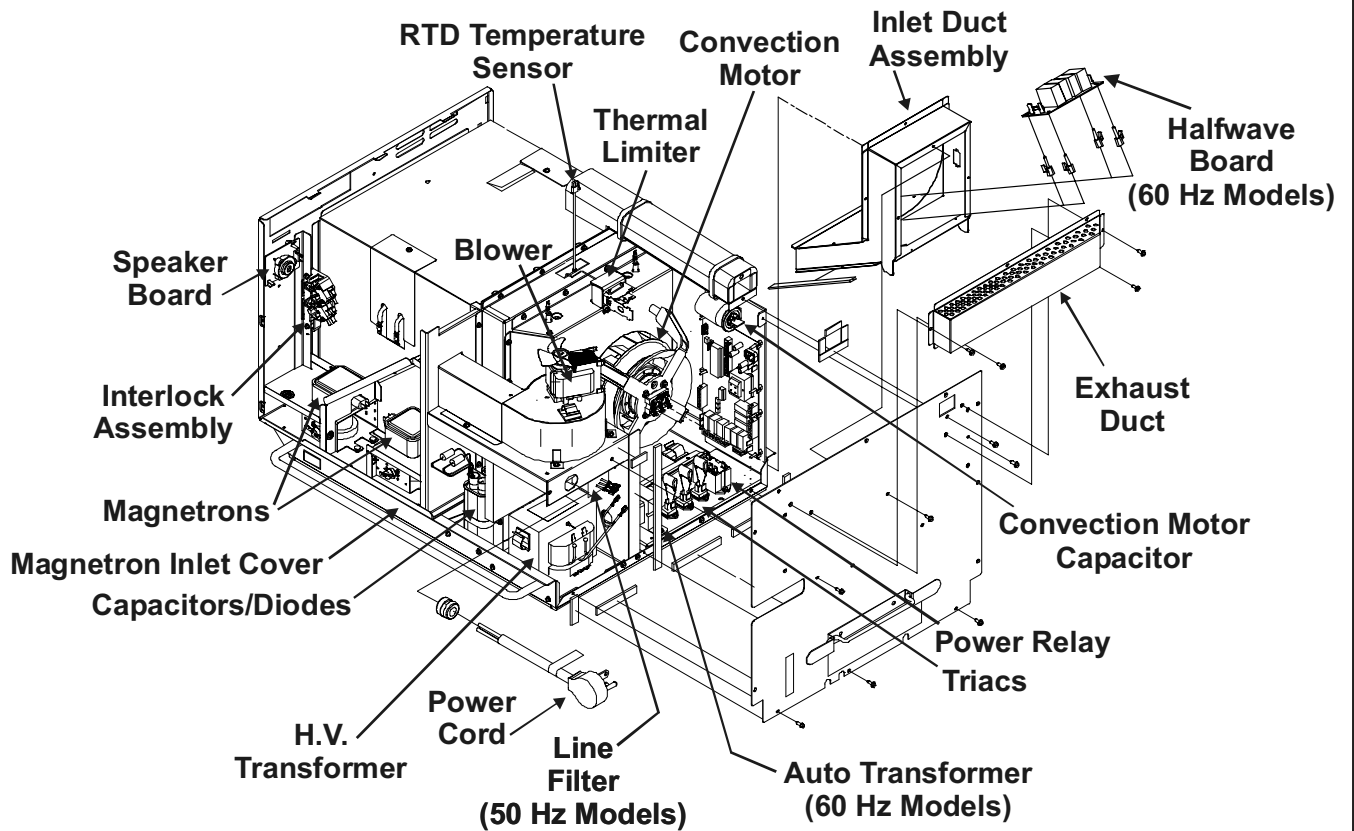

Figure 3  
Overview

# Disassembly



## WARNING

To avoid the risk of electrical shock, personal injury, or death, disconnect power to oven and discharge capacitors before following any disassembly procedure.

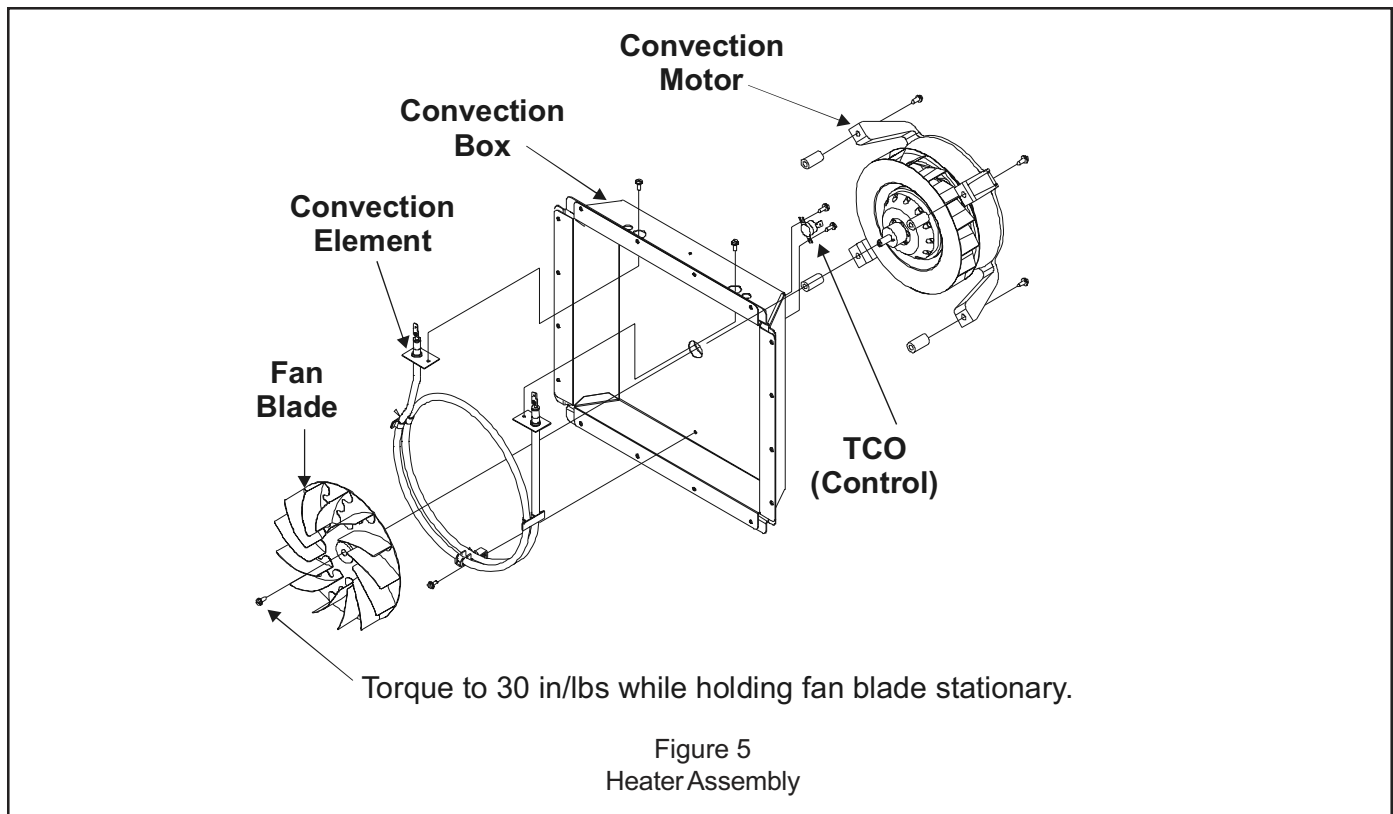
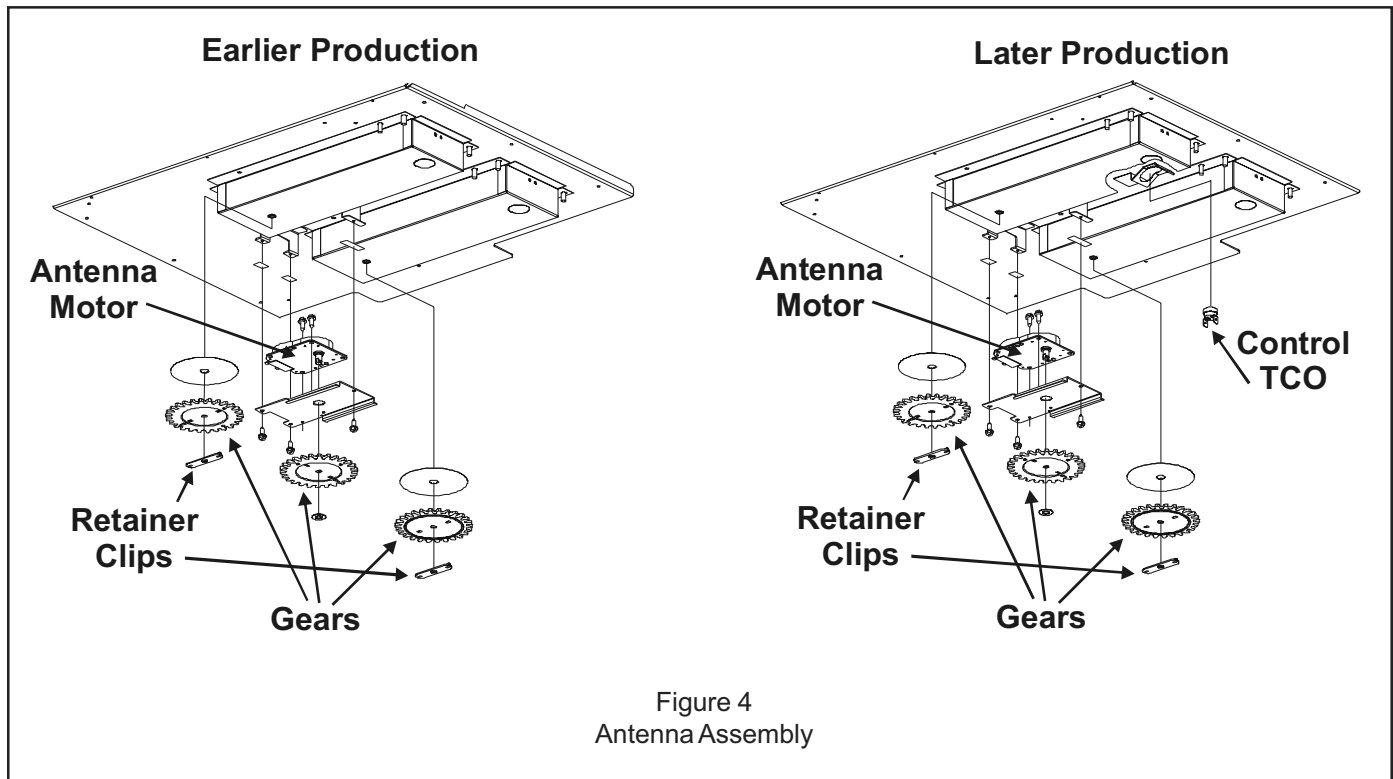

# Appendix A



# Owner's Manual



## High Speed Commercial Combination Oven

Keep these instructions for future reference. If the equipment changes ownership, be sure this manual accompanies equipment.

### Contents

Model Identification .....	2
<b>PRECAUTIONS TO AVOID POSSIBLE EXPOSURE TO EXCESSIVE MICROWAVE ENERGY .....</b>	<b>2</b>
<b>IMPORTANT SAFETY INSTRUCTIONS .....</b>	<b>3</b>
Grounding Instructions .....	5
Installation .....	5
Display and Features .....	6
Cooking and Toasting .....	9
Care and Cleaning .....	12
Service Codes .....	13
Troubleshooting .....	13

# Model Identification

---

When contacting Amana, provide product information. Product information is located on oven serial plate. Record the following information:

Model Number: \_\_\_\_\_  
Serial or S/N Number: \_\_\_\_\_  
Date of installation: \_\_\_\_\_  
Dealer's name and address: \_\_\_\_\_  
\_\_\_\_\_  
\_\_\_\_\_

Any questions or to locate an authorized Amana servicer, call toll free 1-866-426-2621 inside the U.S.A. or Canada, or 1-319-622-5511 outside the U.S.A. or Canada.

Warranty service must be performed by an authorized Amana servicer. Amana also recommends contacting an authorized Amana servicer, or call toll free 1-866-426-2621 inside the U.S.A. or Canada if service is required after warranty expires.

## PRECAUTIONS TO AVOID POSSIBLE EXPOSURE TO EXCESSIVE MICROWAVE ENERGY

- A. **DO NOT** attempt to operate this oven with the door open since open door operation can result in harmful exposure to microwave energy. It is important not to defeat or tamper with the safety interlocks.
- B. **DO NOT** place any object between the oven front face and the door or allow soil or cleaner residue to accumulate on sealing surfaces.
- C. **DO NOT** operate the oven if it is damaged. It is particularly important that the oven door close properly and that there is no damage to the:
  - 1. door (bent)
  - 2. hinges and latches (broken or loosened)
  - 3. door seals and sealing surfaces.
- D. The oven should not be adjusted or repaired by anyone except properly qualified service personnel.

# IMPORTANT SAFETY INSTRUCTIONS



Recognize this symbol as a SAFETY message



## WARNING

When using electrical equipment, basic safety precautions should be followed to reduce the risk of burns, electrical shock, fire, or injury to persons.

1. **READ** all instructions before using equipment.
2. **READ AND FOLLOW** the specific **PRECAUTIONS TO AVOID POSSIBLE EXPOSURE TO EXCESSIVE MICROWAVE ENERGY** on page 2.
3. This equipment **MUST BE GROUNDED**. Connect only to properly grounded outlet. See **GROUNDING INSTRUCTIONS** on page 5.
4. Install or locate this equipment **ONLY** in accordance with the installation instructions in this manual.
5. Some products such as whole eggs and sealed containers—for example, closed glass jars—are able to explode and **SHOULD NOT** be **HEATED** in this oven.
6. Use this equipment **ONLY** for its intended use as described in this manual. Do not use corrosive chemicals or vapors in this equipment. This type of oven is specifically designed to heat or cook. It is not designed for industrial or laboratory use.
7. As with any equipment, **CLOSE SUPERVISION** is necessary when used by **CHILDREN**.
8. See door cleaning instructions in *Care and Cleaning* section of manual on page 12.
9. **DO NOT** heat baby bottles in oven.
10. Baby food jars shall be open when heated and contents stirred or shaken before consumption, in order to avoid burns.
11. **DO NOT** operate this equipment if it has a damaged cord or plug, if it is not working properly, or if it has been damaged or dropped.
12. This equipment, including power cord, must be serviced **ONLY** by qualified service personnel. Special tools are required to service equipment. Contact nearest authorized service facility for examination, repair, or adjustment.
13. **DO NOT** cover or block any openings on the equipment.
14. **DO NOT** store this appliance outdoors. **DO NOT** use this product near water – for example, near a kitchen sink, in a wet basement, near a swimming pool, or similar locations.
15. **DO NOT** immerse cord or plug in water.
16. Keep cord **AWAY** from **HEATED** surfaces.
17. **DO NOT** let cord hang over edge of table or counter.
18. For commercial use only.
19. **DO NOT** insert oversized foods or oversized utensils in a microwave/convection oven as they may create a fire, an electrical arc, or risk of electrical shock.
20. **DO NOT** clean with metal scouring pads. Pieces can break off the pad and touch electrical parts involving risk of electrical shock.
21. **DO NOT** use paper products not intended for cooking when equipment is operated in convection or combination mode.
22. **DO NOT** store any materials, other than manufacturer's recommended accessories, in this equipment when not in use.
23. **DO NOT** cover any part of the oven with metal foil. Airflow restriction will cause overheating of the oven.
24. **DO NOT** spray oven cleaning solutions toward the rear inner cavity surface. This will

## SAVE THESE INSTRUCTIONS

# IMPORTANT SAFETY INSTRUCTIONS

## WARNING

To avoid risk of fire in the oven cavity:

- a. DO NOT overcook food. Carefully attend oven when paper, plastic, or other combustible materials are placed inside the oven to facilitate cooking.
- b. Remove wire twist-ties from paper or plastic bags before placing bag in oven.
- c. If materials inside the oven ignite, keep oven door CLOSED, turn oven off and disconnect the power cord, or shut off power at the fuse or circuit breaker panel.
- d. DO NOT use the cavity for storage. DO NOT leave paper products, cooking utensils, or food in the cavity when not in use.

## WARNING

Liquids such as water, coffee, or tea are able to be overheated beyond the boiling point without appearing to be boiling due to surface tension of the liquid. Visible bubbling or boiling when the container is removed from the microwave oven is not always present. THIS COULD RESULT IN VERY HOT LIQUIDS SUDDENLY BOILING OVER WHEN A SPOON OR OTHER UTENSIL IS INSERTED INTO THE LIQUID. To reduce the risk of injury to persons:

- i) Do not overheat the liquid.
- ii) Stir the liquid both before and halfway through heating it.
- iii) Do not use straight-sided containers with narrow necks.
- iv) After heating, allow the container to stand in the microwave oven for a short time before removing the container.
- v) Use extreme care when inserting a spoon or other utensil into the container.

## CAUTION

To avoid risk of personal injury or property damage, observe the following:

1. **Do not** deep fat fry in oven. Fat could overheat and be hazardous to handle.
2. **Do not** cook or reheat eggs in shell or with an unbroken yolk using microwave energy. Pressure may build up and erupt. Pierce yolk with fork or knife before cooking.
3. Pierce skin of potatoes, tomatoes, and similar foods before cooking with microwave energy. When skin is pierced, steam escapes evenly.
4. **Do not** pop popcorn in this oven.
5. **Do not** use regular cooking thermometers in oven when cooking in microwave or combination mode. Most cooking thermometers contain mercury and may cause an electrical arc, malfunction, or damage to oven.
6. **Do not** use metal utensils in oven except when recommended by microwave food manufacturers or recipe requires metal utensils in convection or combination mode. Heat food in containers made of glass or china if possible.
7. Never use paper, plastic, or other combustible materials that are not intended for cooking. If oven temperature is high, material may ignite.
8. Oven temperature is at least 425°F in convection mode. Verify plastic, paper or other combustible materials are recommended by the manufacturer to withstand the maximum oven temperature.
9. When cooking with paper, plastic, or other combustible materials, follow manufacturer's recommendations on product use.
10. **Do not** use paper towels which contain nylon or other synthetic fibers. Heated synthetics could melt and cause paper to ignite.
11. **Do not** heat sealed containers or plastic bags in oven. Food or liquid could expand quickly and cause container or bag to break. Pierce or open container or bag before heating.
12. Racks, utensils, rack guides, and oven surfaces may become hot during or after use. Use utensils or protective clothing, like pan grips or dry oven mitts, when necessary to avoid burns.
13. **Do not** unplug oven immediately after use. Internal fan must cool oven to avoid damage of electrical components.
14. To avoid pacemaker malfunction, consult physician or pacemaker manufacturer about effects of microwave energy on pacemaker.

## SAVE THESE INSTRUCTIONS

## Unpacking Oven

- Inspect oven for damage such as dents in door or inside oven cavity.
- Report any dents or breakage to source of purchase immediately.  
**Do not attempt to use oven if damaged.**
- Remove all packing materials from oven interior.
- If oven has been stored in extremely cold area, wait a few hours before connecting power.

## Radio Interference

Microwave operation may cause interference to radio, television, or a similar oven. Reduce or eliminate interference by doing the following:

- Clean door and sealing surfaces of oven according to instructions in *Care and Cleaning* section.
- Place radio, television, etc. as far as possible from oven.
- Use a properly installed antenna on radio, television, etc. to obtain stronger signal reception.

## Oven Placement

- Recommended countertop surface depth is 26".
- Do not install oven next to or above source of heat, such as pizza oven or deep fat fryer. This could cause microwave oven to operate improperly and could shorten life of electrical parts.
- Do not block or obstruct oven filter. Allow access for cleaning.
- Install oven on level countertop surface.
- Outlet should be located so that plug is accessible when oven is in place.

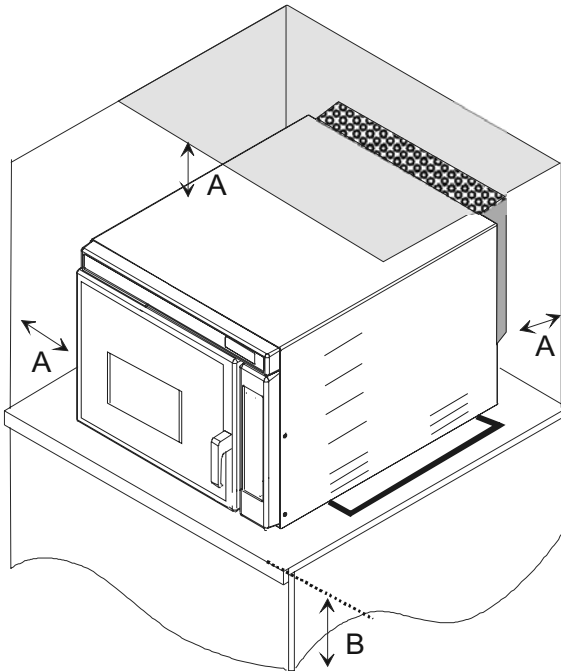

A—Allow at least 2" (5.1 cm) of clearance around top, back and sides of oven. Proper air flow around oven cools electrical components. With restricted air flow, oven may not operate properly and life of electrical parts is reduced.

B—Install combination oven so oven bottom is at least 3 feet (91.5 cm) above floor.

Oven Clearances

## WARNING

To avoid risk of electrical shock or death, this oven must be grounded and plug must not be altered.



## Grounding/ Earthing Instructions

### Oven **MUST** be grounded.

Grounding reduces risk of electric shock by providing an escape wire for the electric current if an electrical short occurs. This oven is equipped with a cord having a grounding wire with a grounding plug. The plug must be plugged into an outlet that is properly installed and grounded.

Consult a qualified electrician or servicer if grounding instructions are not completely understood, or if doubt exists as to whether the oven is properly grounded.

### Do not use an extension cord.

If the product power cord is too short, have a qualified electrician install a three-slot receptacle. This oven should be plugged into a separate circuit with the electrical rating as provided in product specifications. When the combination oven is on a circuit with other equipment, an increase in cooking times may be required and fuses can be blown.

### External Equipotential Earthing Terminal *(export only)*

Equipment has secondary earthing terminal. Terminal provides external earthing connection used in addition to earthing prong on plug. Located on outside of oven back, terminal is marked with symbol shown below.



# Display and Features

- A—Oven Door Handle  
(Lift to open.)
- B—Door Shield
- C—Top Control Panel
- D—Display
- E—Side Control Panel

- F—Discharge Air Vent
- G—Air Intake Filter
- H—Exhaust Flue
- I—Unit Spacing Guide
- J—Power Cord

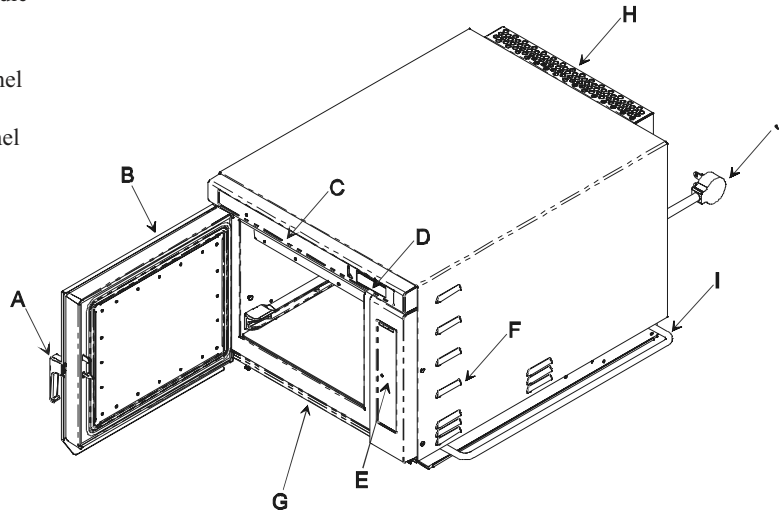

## Oven Features

ITEM flashes in display indicating keypads can be used and cooking entries can be made.

Temperature is displayed in the time field.

Display



PREHEAT NOT READY indicates the oven is not at preheat temperature. NOT flashes while the oven heats to preheat temperature.

If Item is not displayed, keypad will not accept entries. To activate keypad, open and close oven door—Item will then display.



Preheat ready displays when oven has reached the preset preheat temperature.

# Display and Features (cont'd)

Displays stage the oven is cooking in during multi-stage cooking programs.

Displays programmed ITEM digit pad selected by user.



Convection cooking only.

Displays when changing heater setting. Press and hold TEMP ENTRY to display.



Displays when changing fan setting. Press and hold POWER LEVEL to display.

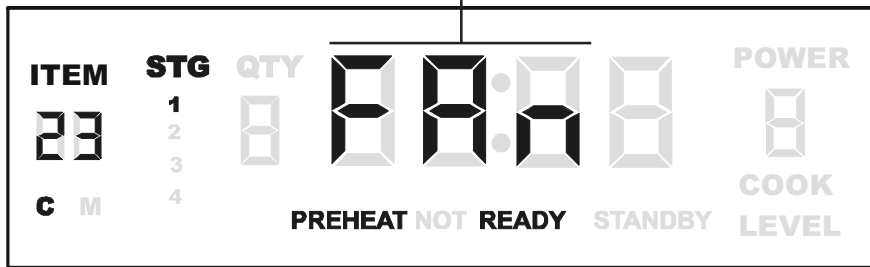

Power displays when oven is actively generating microwave energy. Will not display when set at 0, and will turn on and off when set less than HI.

Time left in cooking condition.



Indicates percentage of microwave power (0 to 100%).  
9 is 90%,  
5 is 50%,  
H is High (100%).

Combination cooking: both convection (C) and microwave energy (M) are used.

Cook level displays with the amount of microwave energy used.

# Display and Features (cont'd)

**Amana**

**Veloci**

PREHEAT  
ON / OFF

TIME  
ENTRY

TEMP  
ENTRY

POWER  
LEVEL

STAGE

PROGRAM  
SAVE

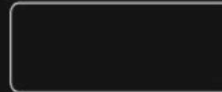

## START Pad

Press the START pad to restart a cooking cycle that was interrupted.



## STOP/RESET Pad

The STOP/RESET pad stops a cooking sequence in progress, and can clear out any remaining time. The first time STOP/RESET is pressed, it will pause the current cooking cycle. The second time STOP/RESET is pressed, the remaining time will be cleared from the oven.

## Cooking Display

DISPLAYS	DESCRIPTION
<b>PREHEAT READY</b>	<b>PREHEAT READY</b> displays when oven has reached preheat temperature and is ready to cook.
00:00	Displays cooking time. If stage cooking is programmed, total cooking time is displayed.
<b>PREHEAT NOT READY</b>	<b>PREHEAT NOT READY</b> displays with <b>NOT</b> flashing when oven is turned on and warming to preheat temp. (475°F factory default preheat setting or 450°F)
<b>COOK LEVEL</b>	<b>COOK LEVEL</b> displays the current microwave power level. HI is the highest setting, and 0 is lowest (no microwave energy used).
<b>ITEM</b>	<b>ITEM</b> displays the single or double digit entry of a cooking program when using a programmed pad. <b>ITEM</b> also flashes when a cooking condition can be started or programmed.
<b>STG</b>	<b>STG</b> displays with a single number. This is the stage the oven is at in the cooking program.
<b>STANDBY</b>	<b>STANDBY</b> displays when the oven is plugged in, and turned off.
<b>C M</b>	<b>C M</b> displays when oven is convection cooking.
<b>C M</b>	<b>C M</b> displays when oven is cooking using both microwave energy and convection.
<b>POWER</b>	<b>POWER</b> displays during active microwave energy in the oven. <b>POWER</b> will not display when power setting is at 0; and <b>POWER</b> will turn on and off when microwave energy is set at less than HI.
<b>CLEAN FILTR</b>	Displays every 7 days after start up of oven. Will disappear after 24 hours. This is to remind you to clean the filter.
<b>HTR</b>	Displays when changing heater setting. Press and hold TEMP ENTRY to display (in programming mode).
<b>FAN</b>	Displays when changing fan setting. Press and hold POWER LEVEL to display (in programming mode).

# Using the Oven Control



## CAUTION

To avoid risk of burns, handle utensils, accessories, and door with care. Allow oven, utensils, and accessories to cool before cleaning. Oven, utensils, and accessories become hot during operation.

## Cooking with Preprogrammed Pads

This combination oven has been programmed in the factory for all the food that will need to be cooked and prepared. Follow the steps outlined below to ensure food is cooked properly and evenly.

1. Press PREHEAT ON/OFF to start the oven.
  - Oven begins a preheat cycle.
  - **PREHEAT NOT READY** displays with **NOT** flashing.
2. Oven reaches preheat temperature.
  - Signal sounds and **PREHEAT READY** displays.
3. Enter selected item number using digit pad(s).
  - **ITEM** must be flashing in display. If not, open and close door.
  - If using single digit programming, press pad and oven begins automatically.
  - For double digit programming, press pads in proper sequence and oven begins automatically.
4. Cooking cycle begins
  - Total cooking time is displayed.
5. Oven finishes cooking sequence
  - An end of cycle beep signals the end of the cooking cycle.
  - **Oven interior and accessories will be hot.**



## ? The keypad doesn't work.

The keypad is designed only to accept time entry within so many seconds after the oven door is closed. To start keypad entry, simply

## Programming Preheat Setting

The convection temperature setting can be set between 240°C to 250°C (450°F to 475°F). It is recommended to set the preheat setting to the most commonly used temperature. The factory default preheat setting is 250°C (475°F).

### To program the preheat setting:

1. Press PROGRAM SAVE pad.
2. Press TEMP pad.
3. Enter desired temperature by using the numeric key pads.
4. Preheat temperature is changed.

## Manual Operation

To cook food using a specific entered time and power level.

1. Press PREHEAT ON/OFF to start the oven.
  - Preheat temperature and **PREHEAT NOT READY** displays with **NOT** flashing.
2. Oven reaches preheat temperature.
  - Signal sounds and **PREHEAT READY** displays.
3. **ITEM** must be flashing in display. If not, open and close oven door.
4. Press TIME ENTRY to program amount of cooking time.
  - Enter desired cooking time by using numeric keypad.
  - The total microwave cooking time (all stages combined) is 20 minutes.
5. Press and hold TEMP ENTRY to program the radiant heater. **HTR** shows in the display. Radiant heater setting automatically defaults to 9 (highest).
  - Set radiant heater by pressing pads 0 through 9.
  - Pad 1 is the lowest heater setting; pad 9 is the highest heater setting. **0 turns off radiant heater.**
6. Press and hold POWER LEVEL to program fan speed. **FAn** shows in the display. Fan speed setting automatically defaults to 9 (fastest).
  - Set fan speed by pressing pads 1 through 9.
  - Pad 1 is the slowest fan speed; pad 9 is the fastest fan speed.
7. Press POWER LEVEL to program level of microwave power. Power level automatically defaults to High (100%).
  - For a lower microwave power, press pads 1 (for 10%) through 9 (for 90%). **0 turns off microwave power.**
8. If stage cooking is desired, press STAGE.
  - Enter cook time, radiant setting, fan setting, and power level for each stage by repeating steps 4-8.
  - To enter another cooking stage for that pad, press STAGE pad again. Up to four different stages can be programmed for a total of 20 minutes microwave cooking time.
9. Place food in oven and press the START pad to begin the cooking cycle.

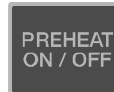

# Programming the Oven

## Programming Items

1. Oven must be ON.
  - Press PREHEAT ON/OFF.
  - **ITEM** must flash in display. If not, open and close oven door.
2. Press PROGRAM SAVE.
3. Press pad to be programmed or reprogrammed.
4. Press TIME ENTRY to program amount of cooking time.
  - Enter desired cooking time by using numeric keypad.
  - The total microwave cooking time (all stages combined) is 20 minutes.
5. Press and hold TEMP ENTRY to program the radiant heater. **HTr** shows in the display. Radiant heater setting automatically defaults to 9 (highest).
  - Set radiant heater by pressing pads 0 through 9.
  - Pad 1 is the lowest heater setting; pad 9 is the highest heater setting. **0 turns off radiant heater.**
6. Press and hold POWER LEVEL to program fan speed. **FAn** shows in the display. Fan speed setting automatically defaults to 9 (fastest).
  - Set fan speed by pressing pads 1 through 9.
  - Pad 1 is the slowest fan speed; pad 9 is the fastest fan speed.
7. Press POWER LEVEL to program level of microwave power. Power level automatically defaults to High (100%).
  - For a lower microwave power, press pads 1 (for 10%) through 9 (for 90%). **0 turns off microwave power.**
8. If stage cooking is desired, press STAGE.
  - Enter cook time, radiant setting, fan setting, and power level for each stage by repeating steps 4-8.
  - To enter another cooking stage for that pad, press STAGE pad again. Up to four different stages can be programmed for a total of 20 minutes microwave cooking time.
9. Press the PROGRAM SAVE pad to save the programming into the pad.

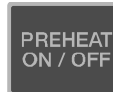

### What is stage cooking?



Stage cooking enables up to four different cooking cycles, or stages, to be used consecutively without repeated input from the user.

Example of Stage Cooking Conditions

	Stage 1	Stage 2	Stage 3	Stage 4
<b>Temp</b>	250°C	250°C	250°C	250°C
<b>Power</b>	H (high)	3	0	0
<b>Time</b>	2:30	1:30	1:30	1:00
<b>Heater</b>	9	9	5	5
<b>Fan</b>	9	9	5	5

## CLEAN FILTR

This oven displays CLEAN FILTR every 7 days. When the message displays, Amana recommends cleaning the air filter thoroughly. **Cleaning the air filter will not shut off the message.** The message will automatically stop displaying after 24 hours. Depending on microwave use and environmental conditions, the filter may need to be cleaned more or less frequently. Once the frequency is determined, set the option for the appropriate time frame.

Air filter and vents must be cleaned regularly to prevent overheating of the oven. Refer to Owner's Manual for complete cleaning instructions.

## Can I change an option?

Options such as single or double digit pad programming and beep volume can be changed to suit individual preferences.

**To change options, STANDBY must display. If STANDBY is not displayed, press PREHEAT ON/OFF pad.**

1. Press HIDDEN pad.
  - Pad is unmarked and located to the immediate left of PREHEAT ON/OFF pad.
  - Nothing will be displayed when HIDDEN pad is pressed.
2. Press PROGRAM SAVE pad.
  - OP : -- displays. Oven is now in options mode.
3. Press number pad that controls option to be changed.
  - See table below for options.
  - Current option will display.
4. Press number pad again to change the option.
  - Each time pad is pressed, option will change.
  - Match code displayed with code for desired option.
5. Press PROGRAM SAVE pad to save changes.
  - To change additional options, repeat steps 3 - 5.
  - Changes take affect after PROGRAM SAVE pad is pressed.
6. Press STOP/RESET to return to STANDBY, or open and close oven door.

# Care and Cleaning

Clean oven frequently to maximize oven life, performance, and efficiency. A dirty oven cooks inefficiently because moisture, spills, and grease absorb convection and microwave energy.

## WARNING

To avoid electrical shock which can cause severe personal injury or death, unplug power cord or open circuit breaker to oven before cleaning oven.



## CAUTION

To prevent burns, handle utensils, accessories, and door with care. Allow oven, utensils, and accessories to cool before cleaning. Oven, utensils, and accessories become hot during operation.

## Air Filter

Air filter must be cleaned weekly to prevent overheating of oven. The air filter is located directly below the oven door.

1. Remove the filter retaining screws, located on the outside edges of the filter.
2. Remove the air filter.
3. Wash filter in a mild detergent solution made with warm water.
4. Rinse and dry thoroughly.
5. Replace filter and screws.

## Discharge Air Vents

Check for a build up of cooking vapors along discharge louvers on sides and in the back of the oven. Clean the air vent using a damp cloth to ensure proper airflow. Dry thoroughly.

## Magnetic Door Stop

Clean the magnetic door stop using a damp cloth and mild detergent. Dry thoroughly.

## Recommended Cleaning Schedule

### Daily

- Remove accessories including rack guides, and wash with warm soapy water.
- Clean oven cavity with plastic utensil or plastic scouring pad.

### Weekly

- Clean filter when reminder displays.

## Cleaning Oven Exterior

Clean the door and other exterior surfaces with a clean cloth, sponge or nylon pad using a mild detergent and warm water solution. Wring cloth well to remove excess water before wiping oven.

- If spraying solutions into oven cavity, protect interior rear wall from moisture or mist.
- Do not use harsh or abrasive cleaners or cleaners containing ammonia.
- Do not use water pressure type cleaning systems.

## Cleaning Oven Cavity

**Remove accessories including rack guides, prior to cleaning the oven cavity.** Recommended cleaning solution is a commercial degreaser. Repeat cleaning several times if necessary. Saturate oven interior surfaces with degreaser and let sit for 2 to 5 minutes. **DO NOT** spray oven cleaning solutions toward the rear inner cavity surface. This will contaminate and damage the convection heating assembly. Rub vigorously with nylon scouring pad to loosen debris. Wipe clean with warm, damp clean cloth.

**NOTE:** A plastic utensil or equivalent may be used to remove baked on debris.

- Wear protective rubber gloves when cleaning oven.
- Use only a plastic utensil, nylon scouring pad or equivalent, to aid in removing soil or build-up from the oven interior.
- **Do not use knife, metal utensil, or steel wool pad** to remove baked on material.

# Care and Cleaning (cont'd)



## CATALYST DEACTIVATION & POISONING AGENTS

The following partial list of poisoning agents and inhibitors have been found to have a detrimental effect on the activity of the noble metal catalyst. Optimum life and performance of the catalyst requires that exposure to these substances must be avoided.

SUBSTANCE	EFFECT	REMEDIAL ACTION
1. <i>Coating Agents</i> a. rust b. dirt c. inorganic oxides	Covers catalyst active site.	Non-phosphate detergent washing usually effective for removal.
2. <i>Coating Agents - "Glass" Forming Materials</i> a. organic silicates (esters) b. silicones	Covers catalyst active site.	Replacement usually required. Non-phosphate detergent washing may be effective.
3. <i>Poisons</i> a. heavy metals (such as mercury, lead, zinc, tin, arsenic, antimony, etc.) b. phosphorus.	Permanent catalyst deactivation	None, replace with new catalyst.
4. <i>Sulfides</i>	Permanent catalyst deactivation	None, replace with new catalyst.
5. <i>Halogens</i> a. fluorine b. chlorine c. bromine d. iodine e. halogenated hydrocarbons	Low concentration exposure - Occupies active site resulting in inhibition of oxidation reaction. High concentration exposure – Chemical reaction with washcoat components to resulting in permanent deactivation.	Activity usually returns if low concentration source is eliminated. High concentration exposure will require replacement with new catalyst.
6. <i>Organic Droplets and Aerosols</i>	a. Covers active site b. Possible cause of catalyst hot spot	Thermal cleaning in clean air at temperatures 200°F hotter than normal operating point or chemical washing with a strong alkaline solution.

# Before Calling for Service



## WARNING

To avoid electrical shock which can cause severe personal injury or death, do not remove outer case at any time. Only an authorized servicer should remove outer case.

## Service Codes

During operation, the oven may display a service code. **If this should occur:**

**ERR**     

1. Unplug oven and leave unplugged for approximately one minute. Plug oven in and see if code reappears.
  - If code does not reappear, continue normal use with the oven.
2. If service code reappears, write down the service code displayed and contact the nearest authorized Amana servicer.
  - Do not use oven until contacting the authorized Amana servicer or call Amana toll free at 1-866-426-2621 inside the U.S.A. or Canada.

Problem	Possible Cause
Oven does not operate.	Confirm oven is plugged into dedicated circuit. Confirm oven is on grounded circuit. (Contact electrician to confirm) Check fuse or circuit breaker.
Oven operates intermittently.	Check air filter and discharge areas for obstructions.
If oven does not accept entries when pad is pressed.	Make sure oven is on and preheated. Open and close oven door. Press pad again.
If oven malfunctions or shows "ERR":	Oven control is equipped with a self-diagnostic system. Self-diagnostic system alerts you if there is an error or problem. When electronic control signals a problem, follow steps listed below. <ol style="list-style-type: none"> <li>1. Record number shown.</li> <li>2. Unplug oven, wait for 1 minute, and plug in oven.                             <ul style="list-style-type: none"> <li>• Disconnecting electrical supply may eliminate service code. If failure continues, contact an authorized Amana servicer or call Amana toll free at 1-866-426-2621 inside the U.S.A. or Canada.</li> </ul> </li> </ol>
Oven fan turns on while oven is not preheating or cooking.	Normal operation. Will run 45 minutes after oven is turned OFF.
"PREHEAT NOT READY" displays when cook pad is pressed.	Oven is operating normally. Display flashes "PREHEAT NOT READY" if the preheat temperature is different than programmed cooking cycle temperature.
Clean Filtr displays	This is normal and will appear for 24 hours every 7 days. This is a reminder to keep the filter clean to keep the oven in peak performance. The message will turn off by itself; a servicer does not need to be contacted.
HOT displays	Oven's magnetron is overheated. Oven automatically interrupts cooking sequence and turns on cooling fan until normal temperature is reached. When magnetron cools to normal temperature, oven returns to <b>READY</b> mode.
If oven malfunctions or shows "ERR9":	Oven is overheated. When electronic control signals this problem, follow steps listed below. <ol style="list-style-type: none"> <li>1. Make sure holes in back of oven cavity are clean.</li> <li>2. Check air filter.</li> <li>3. Press STOP/RESET pad to clear ERR9.</li> <li>4. Press PREHEAT ON/OFF pad to restart oven.                             <ul style="list-style-type: none"> <li>• If failure continues, contact an authorized Amana servicer or call Amana toll free at 1-866-426-2621 inside the U.S.A. or Canada.</li> </ul> </li> </ol>

# User Options

Numbered Pads	Display	Options (Factory Settings in Bold)
<b>1</b> Preprogrammed Pads	OP:10 OP:11	<b>Allows 10 (0-9) preprogrammed digit pads.</b> Allows 100 (00-99) preprogrammed digit pads.
<b>2</b> Manual Time Entry	OP:20 OP:21	Manual time entry/cooking not allowed <b>Manual time entry/cooking allowed</b>
<b>3</b> Reset to READY mode	OP:30 OP:31	<b>Opening oven door does not reset oven back to ready mode</b> Opening oven door resets the oven back to ready mode
<b>4</b> Keybeep	OP:40 OP:41	Keys do not beep when pressed (keybeep off) <b>Keys beep when pressed (keybeep on)</b>
<b>5</b> Keybeep Volume	OP:50 OP:51 OP:52 OP:53	Keybeep volume OFF Keybeep volume low Keybeep volume medium <b>Keybeep volume high</b>
<b>6</b> Food Done Signal	OP:60 OP:61 OP:62 OP:63	<b>Food done signal is a continuous beep until reset by user</b> Food done signal is a three second beep Food done signal is four beeps, continuously. Food done signal is four beeps, four times
<b>7</b> Keypad Time Entry	OP:70 OP:71 OP:72 OP:73	Keypad time entry window is 15 seconds Keypad time entry window is 30 seconds <b>Keypad time entry window is one minute</b> Keypad time entry window is two minutes
<b>8</b> Temperature Warnings	OP:80 OP:81 OP:82 OP:83	<b>Both temperature warnings off</b> Warning only when preheat temperature does not match preprogrammed temperature Warning only when actual oven cavity temperature is not to preheat temperature Both temperature warnings on
<b>TEMP PAD (b)</b> Temperature Scale	OP:b0 OP:b1	°F °C      °C is default in 50 Hz International models
<b>STAGE PAD (E)</b> Clean Filter Message	OP:E0 OP:E1 OP:E2 OP:E3	Do not display message <b>Display message for 24 hours every 7 days</b> Display message for 24 hours every 30 days Display message for 24 hours every 90 days
<b>POWER LEVEL (A)</b> Altitude Adjustment	OP:A0 OP:A1	<b>Use at an elevation below 5,000 ft.</b> Use at an elevation of 5,000 ft. or above

# Appendix B

# Quick Reference Guide

**Veloci**<sup>™</sup>  
High Speed Commercial  
Combination Oven

## Quick Start Reference Guide

Refer to Product Safety Manual for Safety Statements

Complete Owner's Manual available online

### So...how do I use it?

#### 4 Preprogrammed Pads

To cook food using preprogrammed pads.  
(Example of pad is shown here.)

1. Open oven door, place food in oven and close door.
2. Enter selected item number using digit pad.
3. Cooking cycle begins.
4. At end of cooking cycle, oven beeps and returns to ready mode.

#### Manual Operation

To cook food using a specific entered time and power level.

1. Press PREHEAT ON/OFF to start the oven.
  - Preheat temperature and **PREHEAT NOT READY** displays with **NOT** flashing.
2. Oven reaches preheat temperature.
  - Signal sounds and **PREHEAT READY** displays.
3. **ITEM** must be flashing in display. If not, open and close oven door.
4. Press TIME ENTRY to program amount of cooking time.
  - Enter desired cooking time by using numeric keypad.
  - The total microwave cooking time (all stages combined) is 20 minutes.
5. Press and hold TEMP ENTRY to program the radiant heater. **HTr** shows in the display. Radiant heater setting automatically defaults to 9 (highest).
  - Set radiant heater by pressing pads 0 through 9.
  - Pad 1 is the lowest heater setting; pad 9 is the highest heater setting. **0 turns off radiant heater.**
6. Press and hold POWER LEVEL to program fan speed. **FAn** shows in the display. Fan speed setting automatically defaults to 9 (fastest).
  - Set fan speed by pressing pads 1 through 9.
  - Pad 1 is the slowest fan speed; pad 9 is the fastest fan speed.
7. Press POWER LEVEL to program level of microwave power. Power level automatically defaults to High (100%).
  - For a lower microwave power, press pads 1 (for 10%) through 9 (for 90%). **0 turns off microwave power.**
8. If stage cooking is desired, press STAGE.
  - Enter cook time, radiant setting, fan setting, and power level for each stage by repeating steps 4-8.
  - To enter another cooking stage for that pad, press STAGE pad again. Up to four different stages can be programmed for a total of 20 minutes microwave cooking time.
9. Place food in oven and press the START pad to begin the cooking cycle.

#### Oven Clearances

- A—Allow at least 2" (5.1 cm) of clearance around top, back and sides of oven. Proper air flow around oven cools electrical components. With restricted air flow, oven may not operate properly and life of electrical parts is reduced.
- B—Install combination oven so oven bottom is at least 3 feet (92 cm) above floor.

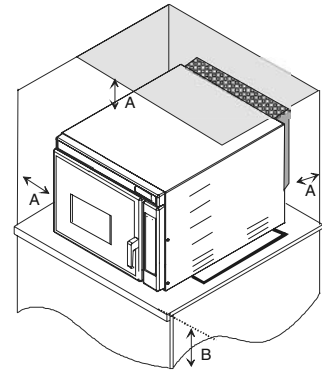

#### Programming Preheat Setting

This oven can be set to a preheat setting of either 450°F (240°C) or the factory default preheat setting of 475°F (250°C).

#### To program the preheat setting:

1. Press PROGRAM SAVE pad.
2. Press TEMP pad.
3. Enter desired temperature by using the numeric key pads.
4. Preheat temperature is changed.

#### Programming Items

1. Oven must be ON.
  - Press PREHEAT ON/OFF.
  - **ITEM** must flash in display. If not, open and close oven door.
2. Press PROGRAM SAVE.
3. Press pad to be programmed or reprogrammed.
4. Follow steps 4 through 8 of "Manual Operation".
9. Press the PROGRAM SAVE pad to save the programming into the pad.

**NOTE:** To discard changes, press STOP/RESET before pressing PROGRAM SAVE.

# Quick Reference Guide

## Quick Start Reference Guide

Refer to Product Safety Manual for Safety Statements

### CLEAN FILTER

This oven displays CLEAN FILTER every 7 days. When the message displays, Amana recommends cleaning the air filter thoroughly.

**Cleaning the air filter will not shut off the message.** The message will automatically stop displaying after 24 hours. Depending on microwave use and environmental conditions, the filter may need to be cleaned more or less frequently. Once the frequency is determined, set the option for the appropriate time frame.

Air filter and vents must be cleaned regularly to prevent overheating of the oven. Refer to Owner's Manual for complete cleaning instructions.



### Can I change an option?

Options such as single or double digit pad programming and beep volume can be changed to suit individual preferences.

**To change options, STANDBY must display. If STANDBY is not displayed, press PREHEAT ON/OFF pad.**

- Press HIDDEN pad.
  - Pad is unmarked and located to the immediate left of PREHEAT ON/OFF pad.
  - Nothing will be displayed when HIDDEN pad is pressed.
- Press PROGRAM SAVE pad.
  - OP:-- displays. Oven is now in options mode.
- Press number pad that controls option to be changed.
  - See table below for options.
  - Current option will display.
- Press number pad again to change the option.
  - Each time pad is pressed, option will change.
  - Match code displayed with code for desired option.
- Press PROGRAM SAVE pad to save changes.
  - To change additional options, repeat steps 3 - 5.
  - Changes take affect after PROGRAM SAVE pad is pressed.
- Press STOP/RESET to return to STANDBY, or open and close oven door.

Numbered Pads	Display	Options (Factory Settings in Bold)
<b>1</b> Preprogrammed Pads	OP:10 OP:11	Allows <b>10 (0-9) preprogrammed digit pads.</b> Allows 100 (00-99) preprogrammed digit pads.
<b>2</b> Manual Time Entry	OP:20 OP:21	Manual time entry/cooking not allowed <b>Manual time entry/cooking allowed</b>
<b>3</b> Reset to READY mode	OP:30 OP:31	<b>Opening oven door does not reset oven back to ready mode</b> Opening oven door resets the oven back to ready mode
<b>4</b> Keybeep	OP:40 OP:41	Keys do not beep when pressed (keybeep off) <b>Keys beep when pressed (keybeep on)</b>
<b>5</b> Keybeep Volume	OP:50 OP:51 OP:52 OP:53	Keybeep volume OFF Keybeep volume low Keybeep volume medium <b>Keybeep volume high</b>
<b>6</b> Food Done Signal	OP:60 OP:61 OP:62 OP:63	<b>Food done signal is a continuous beep until reset by user</b> Food done signal is a three second beep Food done signal is four beeps, continuously. Food done signal is four beeps, four times
<b>7</b> Keypad Time Entry	OP:70 OP:71 OP:72 OP:73	Keypad time entry window is 15 seconds Keypad time entry window is 30 seconds <b>Keypad time entry window is one minute</b> Keypad time entry window is two minutes
<b>8</b> Temperature Warnings	OP:80 OP:81 OP:82 OP:83	<b>Both temperature warnings off</b> Warning only when preheat temperature does not match preprogrammed temperature Warning only when actual oven cavity temperature is not to preheat temperature Both temperature warnings on
<b>TEMP PAD (b)</b> Temperature Scale	OP:b0 OP:b1	°F °C      °C is default in 50 Hz International models
<b>STAGE PAD (E)</b> Clean Filter Message	OP:E0 OP:E1 OP:E2 OP:E3	Do not display message <b>Display message for 24 hours every 7 days</b> Display message for 24 hours every 30 days Display message for 24 hours every 90 days
<b>POWER LEVEL (A)</b> Altitude Adjustment	OP:A0 OP:A1	<b>Use at an elevation below 5,000 ft.</b> Use at an elevation of 5,000 ft. or above