

Service

This manual is to be used by qualified appliance technicians only. Maytag does not assume any responsibility for property damage or personal injury for improper service procedures done by an unqualified person.

2005 Countertop Commercial Microwave Ovens

This Base Manual covers general information
Refer to individual Technical Sheet
for information on specific models

This manual includes, but is
not limited to the following:

ALD10DT
ALD10T

P1331001M
P1331002M

Important Information

Important Notices for Servicers and Consumers

Maytag will not be responsible for personal injury or property damage from improper service procedures. Pride and workmanship go into every product to provide our customers with quality products. It is possible, however, that during its lifetime a product may require service. Products should be serviced only by a qualified service technician who is familiar with the safety procedures required in the repair and who is equipped with the proper tools, parts, testing instruments and the appropriate service information. **IT IS THE TECHNICIANS RESPONSIBILITY TO REVIEW ALL APPROPRIATE SERVICE INFORMATION BEFORE BEGINNING REPAIRS.**



WARNING

To avoid risk of severe personal injury or death, disconnect power before working/servicing on appliance to avoid electrical shock.

To locate an authorized servicer, please consult your telephone book or the dealer from whom you purchased this product. For further assistance, please contact:

Service Support Center

Contact your local product distributor or visit the Web site at www.amanacommercial.com.

Recognize Safety Symbols, Words, and Labels



DANGER

DANGER—Immediate hazards which **WILL** result in severe personal injury or death.



WARNING

WARNING—Hazards or unsafe practices which **COULD** result in severe personal injury or death.



CAUTION

CAUTION—Hazards or unsafe practices which **COULD** result in minor personal injury, product or property damage.

Table of Contents

Important Information	2	Disassembly Procedures	
Important Safety Information	4	Disconnecting Wire Terminals	23
Grounding Instructions	7	Outer Case	23
Servicing of Grounded Products	8	Door Assembly	24
Wiring	8	Door Disassembly	24
Proper Grounding and Polarization of		Control Removal (Electronic)	25
120 Volts Wall Outlets	8	Control panel (Mechanical)	25
Explanation	8	Interlock Assembly	25
Test Procedures (2 Methods)	8	High Voltage Capacitor	26
General Test Information	8	Diode	26
General Information		Transformer	27
Unpacking Equipment	9	Filter Assembly / Fuse	27
Equipment Placement	9	Magnetron	27
Radio Interference	9	Blower Assembly	28
Oven Features	9	Splatter Shield / Antenna	28
Model Identification	9	Stirrer Motor	29
Service	9	Magnetron Thermal Cut-Out (Mag TCO)	29
Parts and Accessories	9	Cavity Thermal Fuse	29
Troubleshooting Procedures	10	Tray Replacement	29
Electronic Models	11-14	Oven Light Assembly	29
Dial Models	15-16	Air Guide	29
Service Information		Appendix A	
Proper Handling of Magnetron Tubes	17	Dial Model - Quick Reference Guide	A-2
Magnetron Failure Mode	17	Electronic Model - Quick Reference Guide	A-3
Microwave Leakage Test			
Equipment	18		
Procedure For Measuring Radiation Leakage	18		
Measurement With the Outer Panel Removed	18		
Measurement With a Fully Assembled Oven	18		
Record Keeping and Notification			
After Measurement	18		
Troubleshooting			
Operating Instructions for Holiday			
HI1501, HI1510, and HI1710	19		
Testing Procedures	20-21		
Power Test	22		

Important Safety Information



WARNING

Read the following information to avoid possible exposure to microwave radiation:

The basic design of the Amana Microwave Oven makes it an inherently safe device to both use and service. However, there are some precautions which should be followed when servicing the Radarange to maintain this safety. These are as follows:

1. Always operate the unit from an adequately grounded outlet. Do not operate on a two-wire extension cord.
2. Before servicing the unit (if unit is operable) perform the microwave leakage test.
3. The oven should never be operated if the door does not fit properly against the seal, the hinges or hinge bearings are damaged or broken, the choke is damaged, (pieces missing, etc.), or any other visible damage can be noted. Check the choke area to ensure that this area is clean and free of all foreign matter.
4. If the oven operates with the door open and produces microwave energy, take the following steps:
 - A. Tell the user not to operate the oven.
 - B. Contact Maytag Amana Manufacturing immediately.
5. Always have the oven disconnected when the outer case is removed except when making the "live" tests called for in the Service Manual. Do not reach into the equipment area while the unit is energized. Make all connections for the test and check them for tightness before plugging the cord into the outlet.
6. Always ground the capacitors on the magnetron filter box with an insulated-handle screwdriver before working in the high voltage area of the equipment compartment. Some types of failures will leave a charge in these capacitors and the discharge could cause a reflex action which could make you injure yourself.
7. Always remember that in the area of the transformer there is HIGH VOLTAGE. When the unit is operating keep this area clear and free of anything which could possibly cause an arc or ground, etc.
8. Do not for any reason defeat the interlock switches. There is not valid reason for this action at any time; nor will it be condoned by Amana.
9. **IMPORTANT:** Before returning a unit to a customer, be sure to check for proper switch interlock action.
10. Before returning a unit to a customer, be sure that the door spacing is reasonably uniform along the top, bottom, and sides, and that it measure 1/8" or less.
11. The Amana Microwave Oven should never be operated with any components removed and/or bypassed or when any of the safety interlocks are found to be defective, or when any of the seal surfaces are defective, missing, or damaged.
12. All Amana Microwave Ovens meet all requirements of the radiation control for Health and Safety Act of 1968. Due to measurement uncertainties, the maximum leakage for the field will be $4\text{mw}/\text{cm}^2$.
13. To ensure that the unit does not emit excessive microwave leakage and to meet the Department of Health and Human Services guidelines, check the oven for microwave leakage using a leakage monitor as outlined in the instruction. The maximum leakage level allowed when following those instructions is $4\text{mw}/\text{cm}^2$.
14. If servicer encounters an emission reading over $4\text{mw}/\text{cm}^2$, the servicer is to cease repair and contact the Amana Service Department immediately for further direction. Amana Manufacturing will contact the proper Government Agency upon verification of the test results.

Important Safety Information



Recognize this symbol as a SAFETY message



WARNING

When using electrical equipment, basic safety precautions should be followed to reduce the risk of burns, electrical shock, fire, or injury to persons.

1. **READ** all instructions before using equipment.
2. **READ AND FOLLOW** the specific “**PRECAUTIONS TO AVOID POSSIBLE EXPOSURE TO EXCESSIVE MICROWAVE ENERGY**”.
3. This equipment **MUST BE GROUNDED**. Connect only to properly GROUNDED outlet. See “**GROUNDED INSTRUCTIONS**”.
4. Install or locate this equipment **ONLY** in accordance with the installation instructions in this manual.
5. Some products such as whole eggs and sealed containers, for example, closed glass jars may explode and **SHOULD NOT** be **HEATED** in this oven.
6. Use this equipment **ONLY** for its intended use as described in this manual. Do not use corrosive chemicals or vapors in this equipment. This type of oven is specifically designed to heat or cook. It is not designed for industrial or laboratory use.
7. As with any equipment, **CLOSE SUPERVISION** is necessary when used by **CHILDREN**.
8. **DO NOT** operate this equipment if it has a damaged cord or plug, if it is not working properly, or if it has been damaged or dropped.
9. This equipment, including power cord, must be serviced **ONLY** by qualified service personnel. Special tools are required to service equipment. Contact nearest authorized service facility for examination, repair, or adjustment.
10. **DO NOT** cover or block filter or other openings on equipment.
11. **DO NOT** store this equipment outdoors. **DO NOT** use this product near water, for example, near a kitchen sink, in a wet basement, or near a swimming pool, and the like.
12. **DO NOT** immerse cord or plug in water.
13. Keep cord **AWAY** from **HEATED** surfaces.
14. **DO NOT** let cord hang over edge of table or counter.
15. See door cleaning instructions in “Care and Cleaning” section.
16. **For commercial use only.**



CAUTION

To reduce risk of fire in the oven cavity:

- a. **DO NOT** overcook food. Carefully attend equipment if paper, plastic, or other combustible materials are placed inside the oven to facilitate cooking.
- b. Remove wire twist-ties from paper or plastic bags before placing bag in oven.
- c. **KEEP** oven **DOOR CLOSED**, turn oven off, and disconnect the power cord, or shut off power at the fuse or circuit breaker panel, if materials inside the oven should ignite. Fire may spread if door is opened.
- d. **DO NOT** use the cavity for storage. **DO NOT** leave paper products, cooking utensils, or food in oven.

SAVE THESE INSTRUCTIONS

Important Safety Information



CAUTION

To avoid risk of personal injury or property damage, observe the following:

1. Briskly stir or pour liquids before heating with microwave energy to prevent spontaneous boiling or eruption. Do not overheat. If air is not mixed into a liquid, liquid can erupt in oven or after removal from oven.
2. Do not deep fat fry in oven. Fat could overheat and be hazardous to handle.
3. Do not cook or reheat eggs in shell or with an unbroken yolk using microwave energy. Pressure may build up and erupt. Pierce yolk with fork or knife before cooking.
4. Pierce skin of potatoes, tomatoes, and similar foods before cooking with microwave energy. When skin is pierced, steam escapes evenly.
5. Do not operate equipment without load or food in oven cavity.
6. Use only popcorn in packages designed and labeled for microwave use. Popping time varies depending on oven wattage. Do not continue to heat after popping has stopped. Popcorn will scorch or burn. Do not leave oven unattended.
7. Do not use regular cooking thermometers in oven. Most cooking thermometers contain mercury and may cause an electrical arc, malfunction, or damage to oven.
8. Do not heat baby bottles in oven.
9. Do not use metal utensils in oven.
10. Never use paper, plastic, or other combustible materials that are not intended for cooking.
11. When cooking with paper, plastic, or other combustible materials, follow manufacturer's recommendations on product use.
12. Do not use paper towels which contain nylon or other synthetic fibers. Heated synthetics could melt and cause paper to ignite.
13. Do not heat sealed containers or plastic bags in oven. Food or liquid could expand quickly and cause container or bag to break. Pierce or open container or bag before heating.
14. To avoid pacemaker malfunction, consult physician or pacemaker manufacturer about effects of microwave energy on pacemaker.

PRECAUTIONS TO AVOID POSSIBLE EXPOSURE TO EXCESSIVE MICROWAVE ENERGY

- a. **DO NOT** attempt to operate this oven with the door open since open-door operation can result in harmful exposure to microwave energy. It is important not to defeat or tamper with the safety interlocks.
- b. **DO NOT** place any object between the oven front face and the door or allow soil or cleaner residue to accumulate on sealing surfaces.
- c. **DO NOT** operate the oven if it is damaged. It is particularly important that the oven door close properly and that there is no damage to the: (1) door (bent), (2) hinges and latches (broken or loosened), (3) door seals and sealing surfaces.
- d. The oven should **NOT** be adjusted or repaired by anyone except properly qualified service personnel.

SAVE THESE INSTRUCTIONS

Important Safety Information

WARNING

Precautions to be observed before and during servicing to avoid possible exposure to excessive microwave energy, or electrical shock disconnect power to oven.

- Do not operate or allow oven to be operated with door open.
- Make the following safety checks on all ovens to be serviced before activating the magnetron or other microwave source, and make repairs as necessary:
 - Interlock operation
 - Proper door closing
 - Seal and sealing surfaces (arcing, wear, and other damage)
 - Damage to or loosening of hinges and latches
 - Evidence of dropping or abuse
- Before turning on microwave power for any service test or inspection within the microwave generating compartments, check the magnetron, waveguide or transmission line, and cavity for proper alignment, integrity, and connections.
- Any failed or misadjusted components in the interlock, monitor, door seal, and microwave generation and transmission systems shall be repaired, replaced or adjusted by procedures described in this manual before oven is released to the consumer.
- Check microwave leakage to verify compliance with the federal performance standard should be performed on each oven prior to release to the consumer.

WARNING

To avoid risk of electrical shock, injury or death; make sure these grounding instructions are followed.

Grounding Instructions

WARNING

Do not remove grounding prong when installing grounded appliance in a home or business that does not have three wire grounding receptacle, under no condition is grounding prong to be cut off or removed. It is the personal responsibility of the consumer to contact a qualified electrician and have properly grounded three prong wall receptacle installed in accordance with appropriate electrical codes.

WARNING

To avoid the risk of electrical shock or death, do not alter the plug.

WARNING

To avoid the risk of electrical shock or death, this equipment must be grounded.

This equipment **MUST** be grounded. In the event of an electrical short circuit, grounding reduces the risk of electric shock by providing an escape wire for the electric current. This oven is equipped with a cord having a grounding wire with a grounding plug. The plug must be plugged into an outlet that is properly installed and grounded.

Consult a qualified electrician or servicer if grounding instructions are not completely understood, or if doubt exists as to whether the equipment is properly grounded.

Do not use an extension cord. If the product power cord is too short, have a qualified electrician install a three-slot receptacle. This oven should be plugged into a separate 60 hertz circuit with the electrical rating as shown in the appropriate drawing. Models operate with a 120 supply voltage. When a microwave oven is on a circuit with other equipment, an increase in cooking times may be required and fuses can be blown.

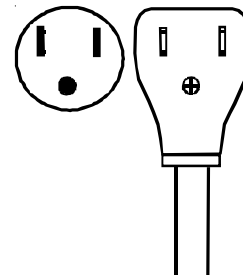

NEMA 5-15R/5-15P
120V-15AMP

Important Safety Information

Servicing of Grounded Products

The standard accepted color coding for grounding wires is GREEN or GREEN WITH YELLOW STRIPE. These ground leads are NOT to be used as current carrying conductors. It is extremely important that the technician replace any and all grounds prior to completion of the service call. Under no condition should ground wire be left off causing a potential hazard to technicians and consumer.

Wiring

A good service practice is never route wiring over terminals and/ or sharp edges. This applies to any wiring without regard to the circuit voltage. Wire installation material and thickness is designed and regulated for electrical spacing purpose only, but cannot always be relied upon because of possible cuts and/or abrasions, which can occur during servicing.

WARNING

To avoid risk of electrical shock, personal injury or death; verify the oven is properly grounded and polarized.

Proper Grounding and Polarization of 120 Volts Wall Outlets

For the safety of our customers and the service technician ALL appliances have a three-prong power cord and MUST be connected to a properly polarized and grounded wall outlet.

This information was written for those who do not understand grounding and polarization of a wall outlet.

A 120 volt wall outlet must always be wired as shown below.

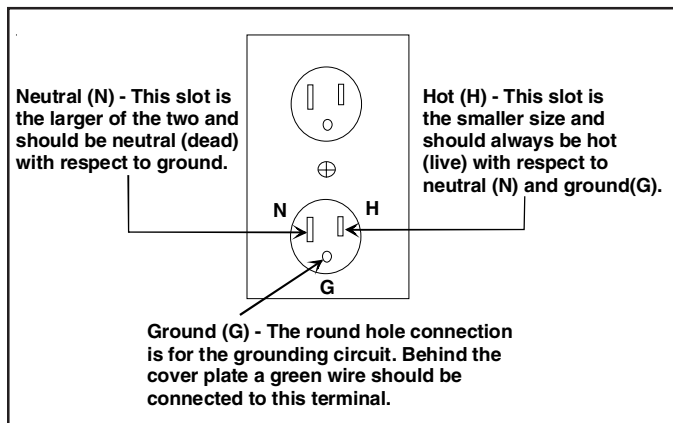

Explanation

Polarization—This means that the larger slot must be neutral and the small slot must be hot (live).

Mispolarized—The outlet is miswired so that the larger slot is hot (live) and the smaller slot is neutral.

Grounded—This means the round hole connection is connected to earth ground through a connection to the main power panel.

Ungrounded—The round hole connection is not complete to earth ground and/or the main power panel.

Test Procedures (2 Methods)

Method #1

Purchase and use a ground monitor available under Amana Part Number R0193001 or it can be purchased locally. The lamps inside the monitor indicate a correctly or incorrectly wired outlet by instructions imprinted on the monitor body.

Method #2

Voltmeter - (Use scale over 125 Volts A.C.)

- Test A - "H" to "N" must indicate line voltage.
- Test B - "H" to "G" must indicate line voltage.
- Test C - "N" to "G" must indicate zero (0) volts.

If "N" to "G" indicates line voltage the outlet is improperly polarized.

If "H" to "G" indicates zero (0) volts the outlet is not grounded.

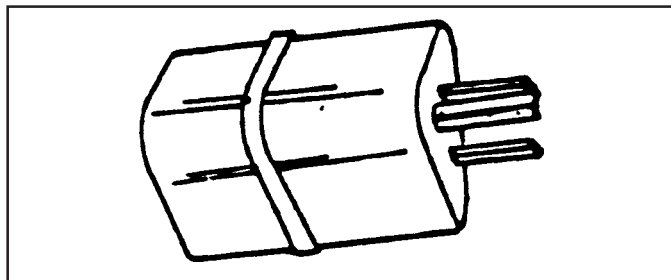

CAUTION

To avoid risk of electrical shock, personal injury or property damage; wiring changes or grounding of wall outlet are to be made only by a qualified electrician.

General Test Information

Most testing in the manual is conducted with an ohmmeter using a multiplier scale of X 10k (k—thousand ohms). When using this scale, it is important that your fingers do not touch the metal parts of the test probes. To do so will give a false indication of the ohm reading.

General Information

Unpacking Equipment

- Inspect equipment for damage such as dents in door or dents inside oven cavity.
- Report any dents or breakage to source of purchase immediately. Do not attempt to use oven if damaged.
- Remove all materials from oven interior.

Equipment Placement

- Do not install equipment next to or above source of heat, such as pizza oven or deep fat fryer. This could cause microwave oven to operate improperly and could shorten life of electrical parts.
- Do not block or obstruct air filter. Allow access for cleaning.
- Install on level countertop surface.

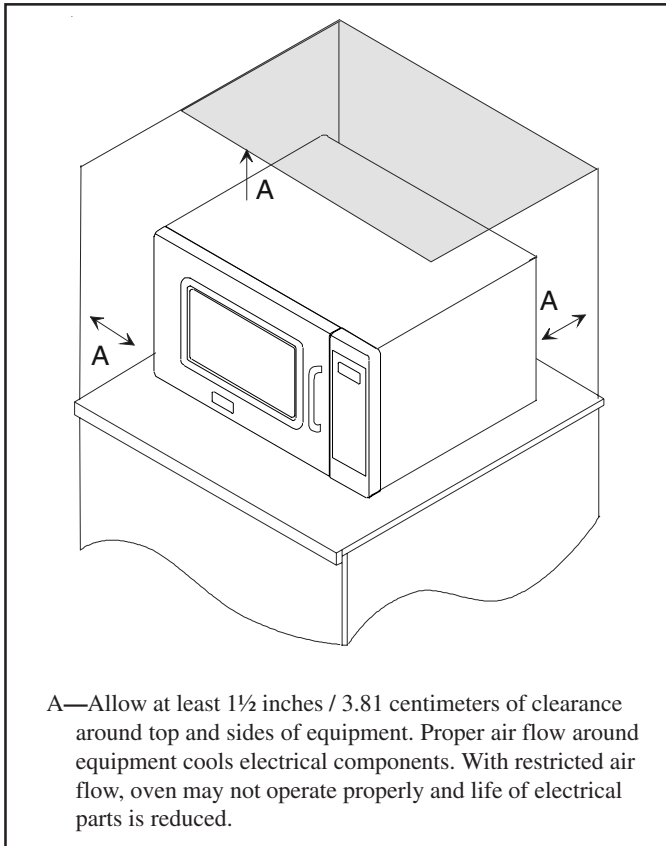

Radio Interference

Microwave operation may cause interference to radio, television, or similar equipment. Reduce or eliminate interference by doing the following:

- Clean door and sealing surfaces of oven according to instructions in “Care and Cleaning” section.
- Place radio, television, etc. as far as possible from oven.
- Use a properly installed antenna on radio, television, etc. to obtain stronger signal reception.

Oven Features

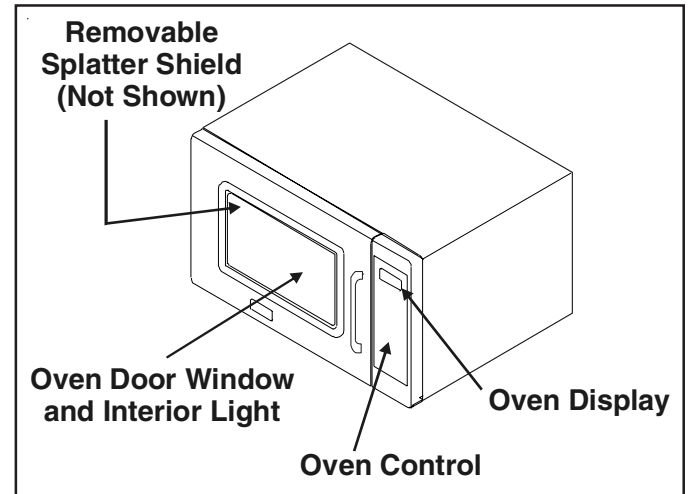

Model Identification

- For Amana product call 1-866-426-2621 or visit the Web Site at www.amanacommercial.com

When contacting for service support, provide product information located on rating plate. Record the following:

Model Number: _____
Manufacturing Number: _____
Serial or S/N Number: _____
Date of purchase: _____
Dealer's name and address: _____

Service

Keep a copy of sales receipt for future reference or in case warranty service is required. To locate an authorized servicer:

- For Amana product call 1-866-426-2621 or visit the Web Site at www.amanacommercial.com

Warranty service must be performed by an authorized servicer. We also recommend contacting an authorized servicer, if service is required after warranty expires.

Parts and Accessories

Purchase replacement parts and accessories over the phone. To order accessories for your product contact your local product distributor or visit the Web site at www.amanacommercial.com.

Troubleshooting Procedures

When you get a complaint from customers, evaluate the complaint carefully. If the following symptoms apply, instruct the customer in the proper use of the microwave oven. This can eliminate an unnecessary service call.



CAUTION

- Verify proper grounding before checking for trouble.
- Be careful of the high voltage circuit.
- Discharge the high voltage capacitor.
- When checking the continuity of the switches or of the high voltage transformer, disconnect one lead wire from these parts and then check continuity with the AC plug removed. To do otherwise may result in a false reading or damage to your meter.
- Do not touch any part of the circuit on the controller, since static electric discharge may damage the control panel. Always touch yourself to earth while working on this panel to discharge any static charge built up in your body.

Condition	Cause	Remedy
Microwave oven does not work.	<ul style="list-style-type: none"> • Inserting multiple plugs into one outlet and using them at the same time (blown fuse or breaker). • Microwave oven plug is not inserted tightly. 	<ul style="list-style-type: none"> • Avoid using other electrical appliances when you use the microwave oven. • Insert microwave oven plug securely.
Output power is too low.	<ul style="list-style-type: none"> • Low AC input voltage. • Food temperature is too low. 	<ul style="list-style-type: none"> • Use the microwave oven at adequate line voltage. • This may not be a defect. It is possible that the food should be cooked for a longer time period.
Sparks occur.	<ul style="list-style-type: none"> • Using metallic ware and allowing it to touch the oven wall. • Ceramic ware trimmed in gold or silver is used. 	<ul style="list-style-type: none"> • Do not use metallic ware for cooking. • Do not use any type of cookware with metallic trimming.
Uneven cooking.	Inconsistent food thickness, inconsistent fat or moisture distribution within the food products.	<ul style="list-style-type: none"> • Use plastic wrap or lid. • Stir once or twice while cooking soup, cocoa, milk, etc.

Troubleshooting Procedures (Electronic Models)

Trouble 1: Oven does not operate at all, no inputs can be accepted.

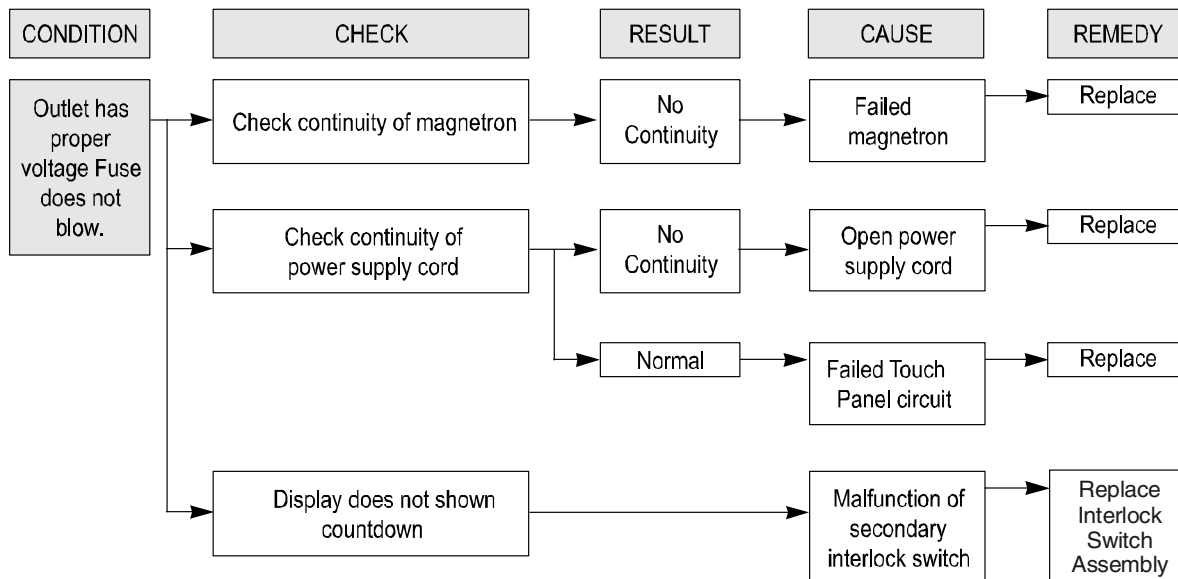
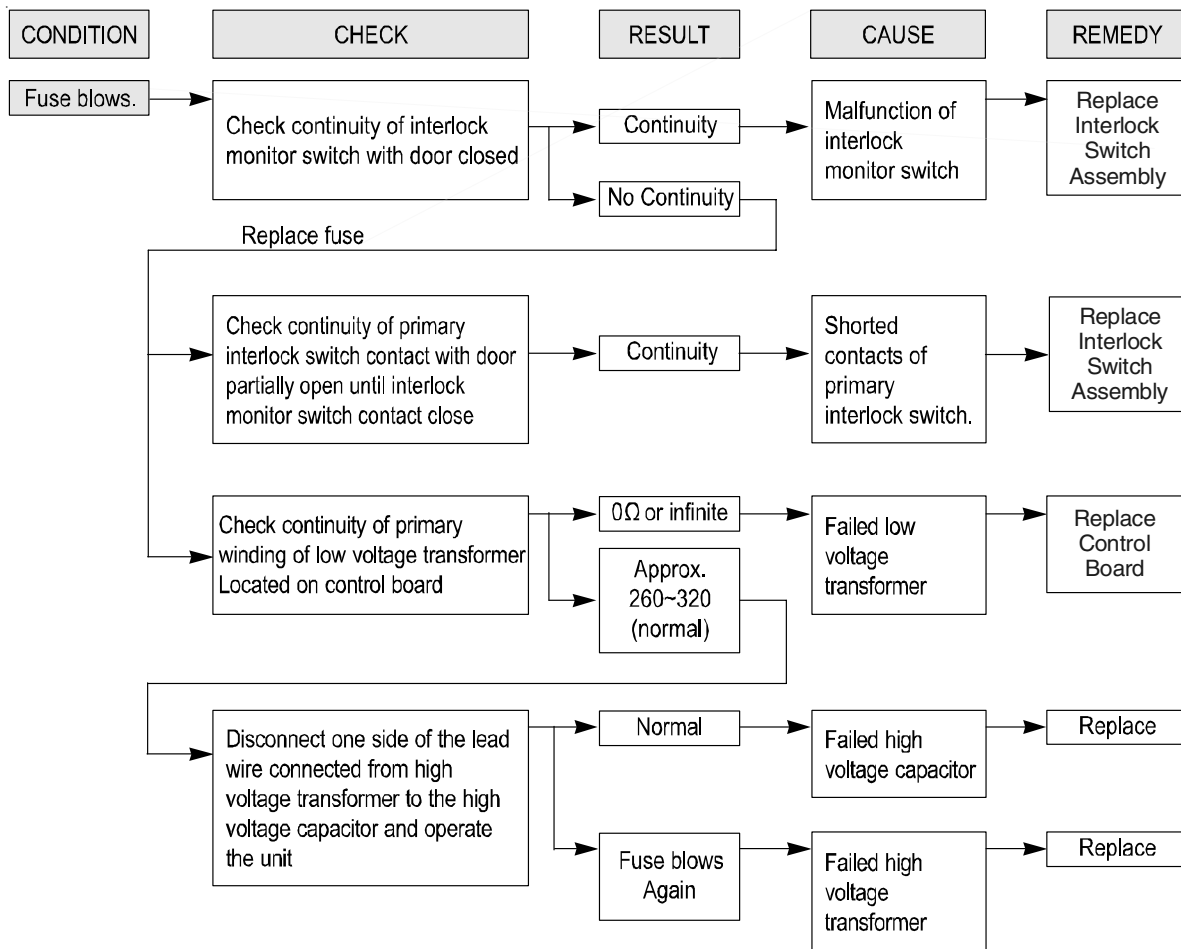

Troubleshooting Procedures (Electronic Models)

Trouble 2: Display shows all figures selected, but does not start cooking even though desired program and time is set when the START pad is pressed.

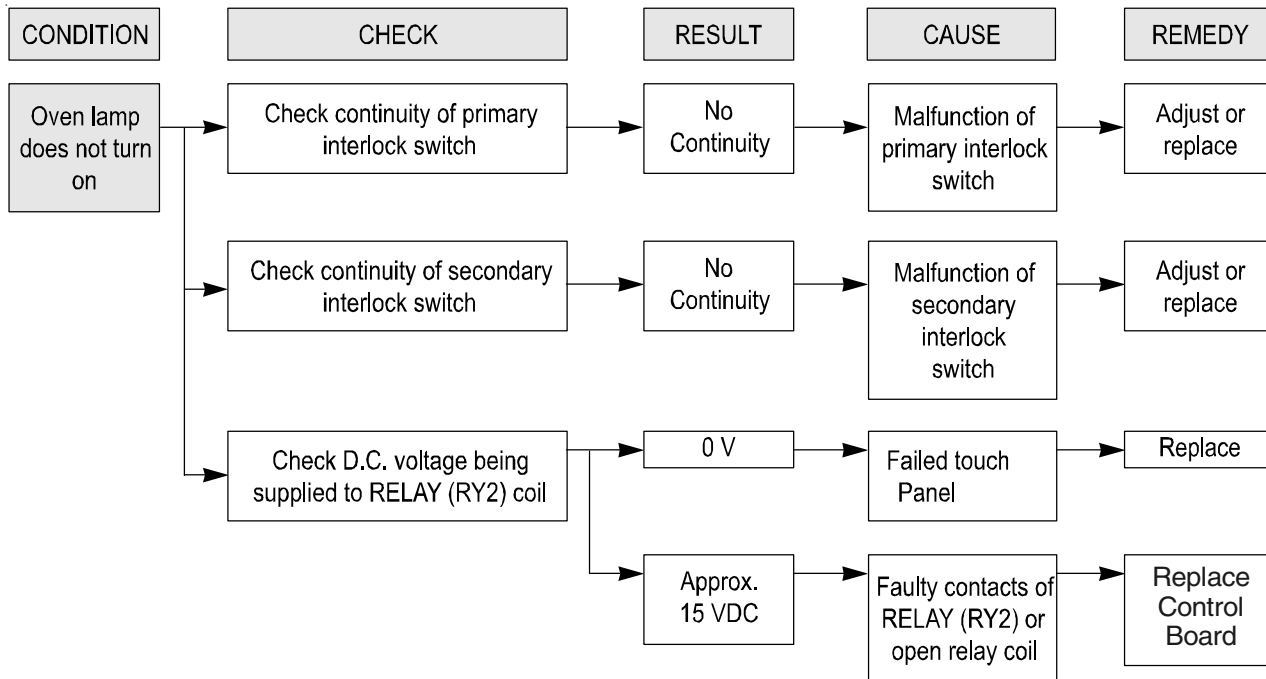

Troubleshooting Procedures (Electronic Models)

Trouble 3: No microwave when fan motor operates.

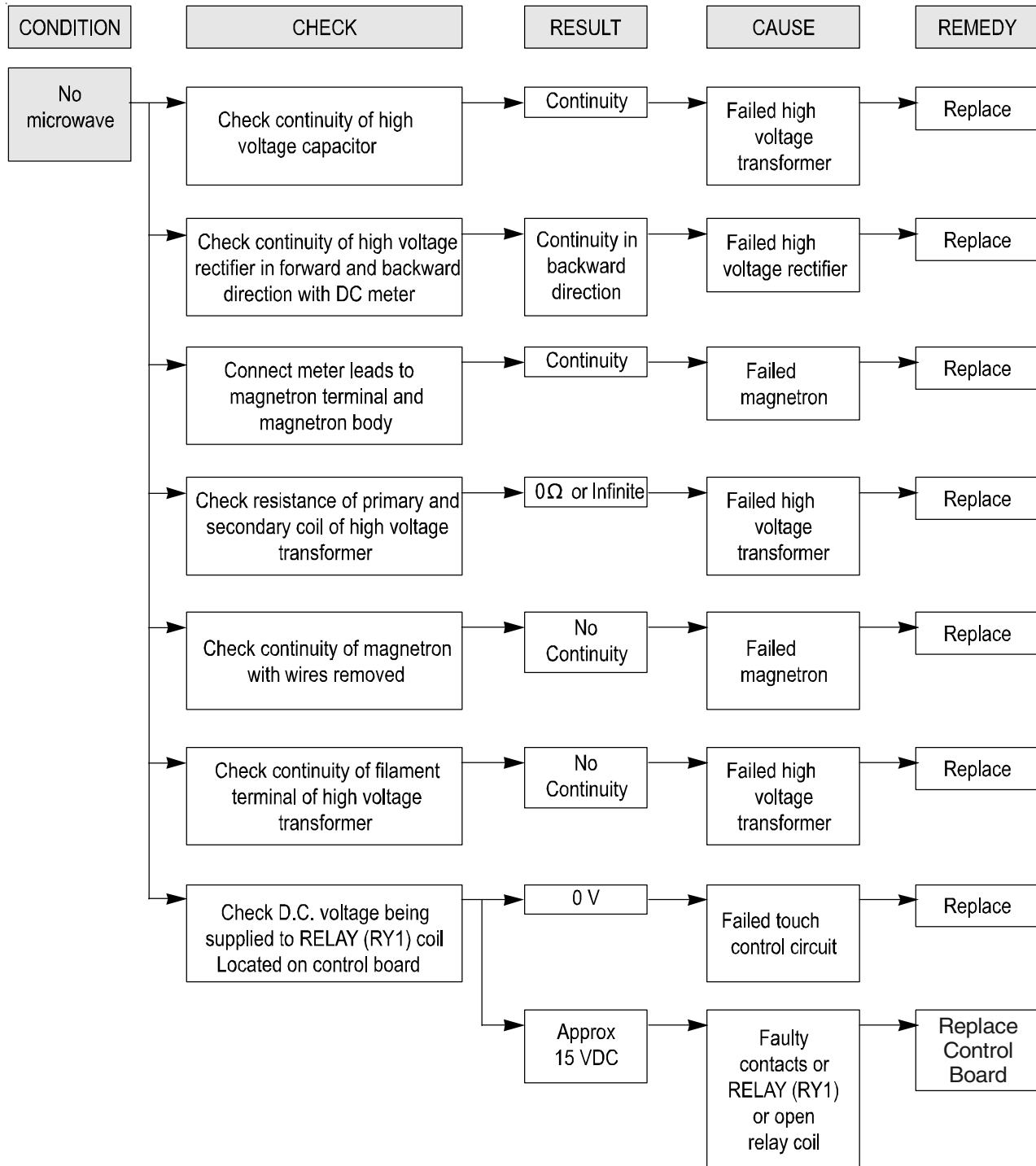

Troubleshooting Procedures (Electronic Models)

Trouble 4: The following visual conditions indicate a probable failed control circuit or membrane switch assembly.

1. Incomplete segments.
 - Segment missing.
 - Partial segment missing.
 - Digit flickering (Note: Slight flickering is normal.)
 - “:0” does not display when power is on.
2. A distinct change in the display is not on, when it should be.
3. One or more digits in the display are not on, when it should be.
4. Display indicates a number different from one touched, for example, key in 5 and 3 appears in the display.
5. Specific numbers (for example 7 or 9) will not display when key pad is touched.
6. Display does not count down or up with time cooking or clock operation.
7. Oven is programmed and cooks normally, but no display is indicated.
8. Display obviously jumps in time while counting down.
9. Display counts down too fast while cooking.
10. Display does not show the time of day when clear pad is touched.
11. Oven lamp and turntable motor do not stop, although cooking is finished. Check if RELAY 2 contacts close, if they are closed, replace touch control circuit.

NOTE: Before following the particular steps listed above for the touch pad, verify continuity of each wire harness between the touch pad and printed circuit board.

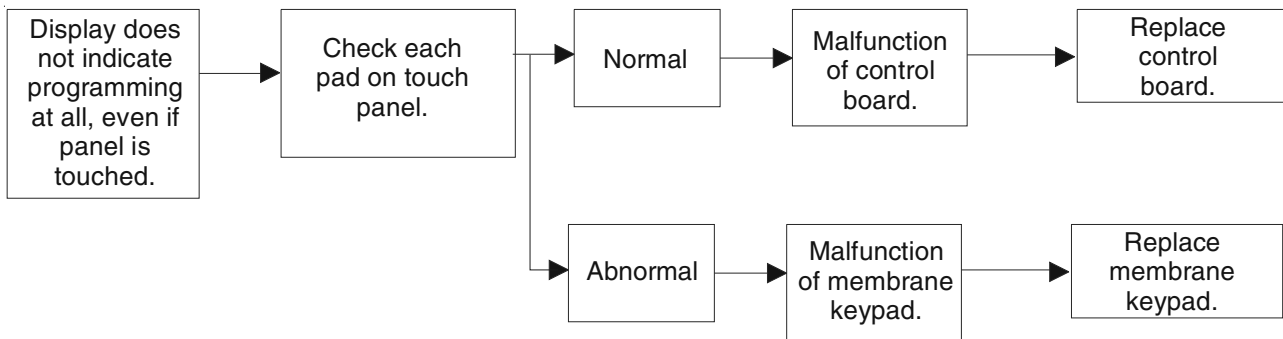

Troubleshooting Procedures (Dial Models)

When you get a complaint from customers, evaluate the complaint carefully. If the following symptoms apply, instruct the customer in the proper use of the microwave oven. This can eliminate an unnecessary service call.



CAUTION

- Verify proper grounding before checking for trouble.
- Be careful of the high voltage circuit.
- Discharge the high voltage capacitor.
- When checking the continuity of the switches or of the high voltage transformer, disconnect one lead wire from these parts and then check continuity with the AC plug removed. To do otherwise may result in a false reading or damage to your meter.
- Do not touch any part of the circuit on the controller, since static electric discharge may damage the control panel. Always touch yourself to earth while working on this panel to discharge any static charge built up in your body.

Trouble 1: Oven does not operate at all, no inputs can be accepted.

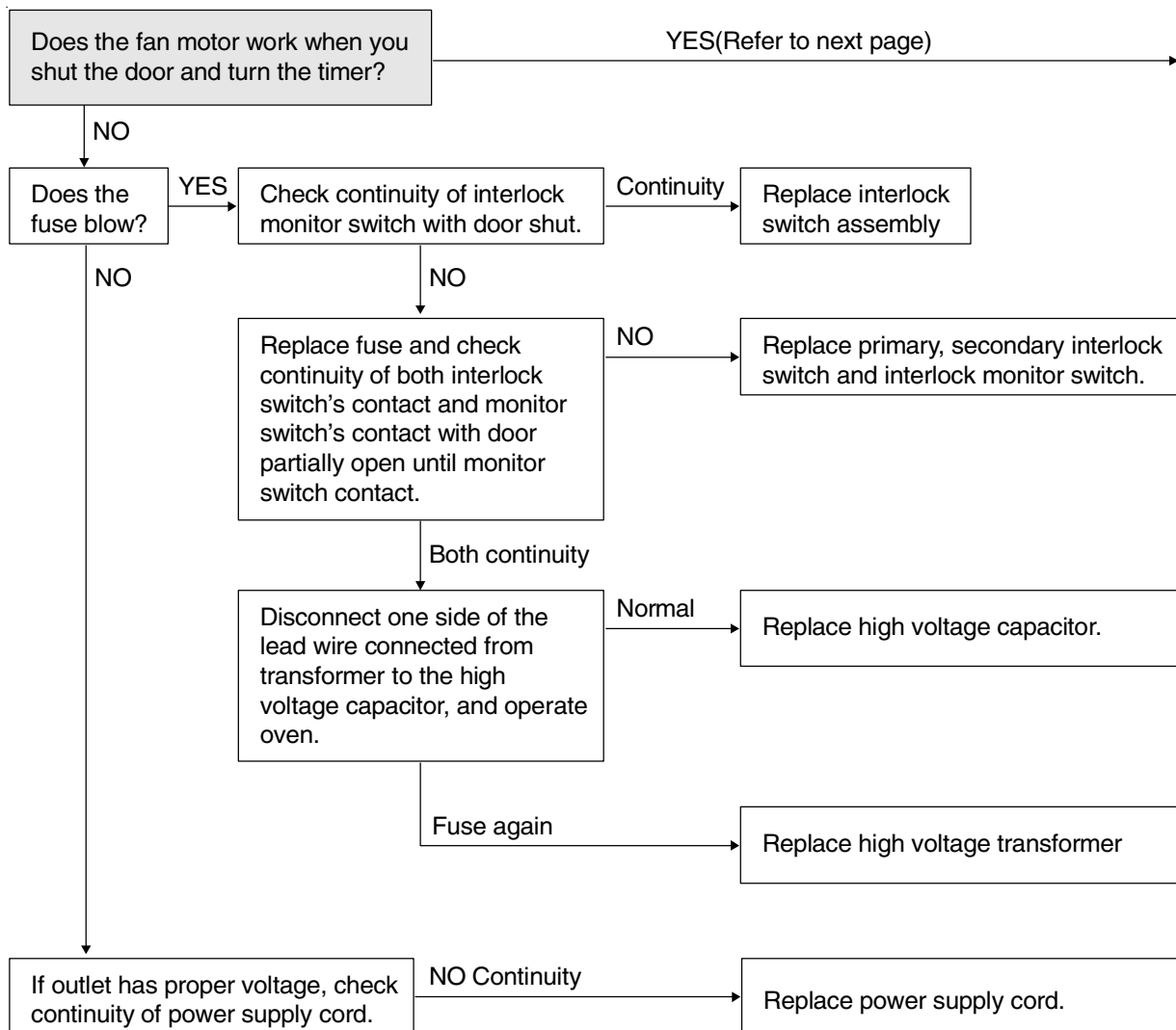

Troubleshooting Procedures (Dial Models)

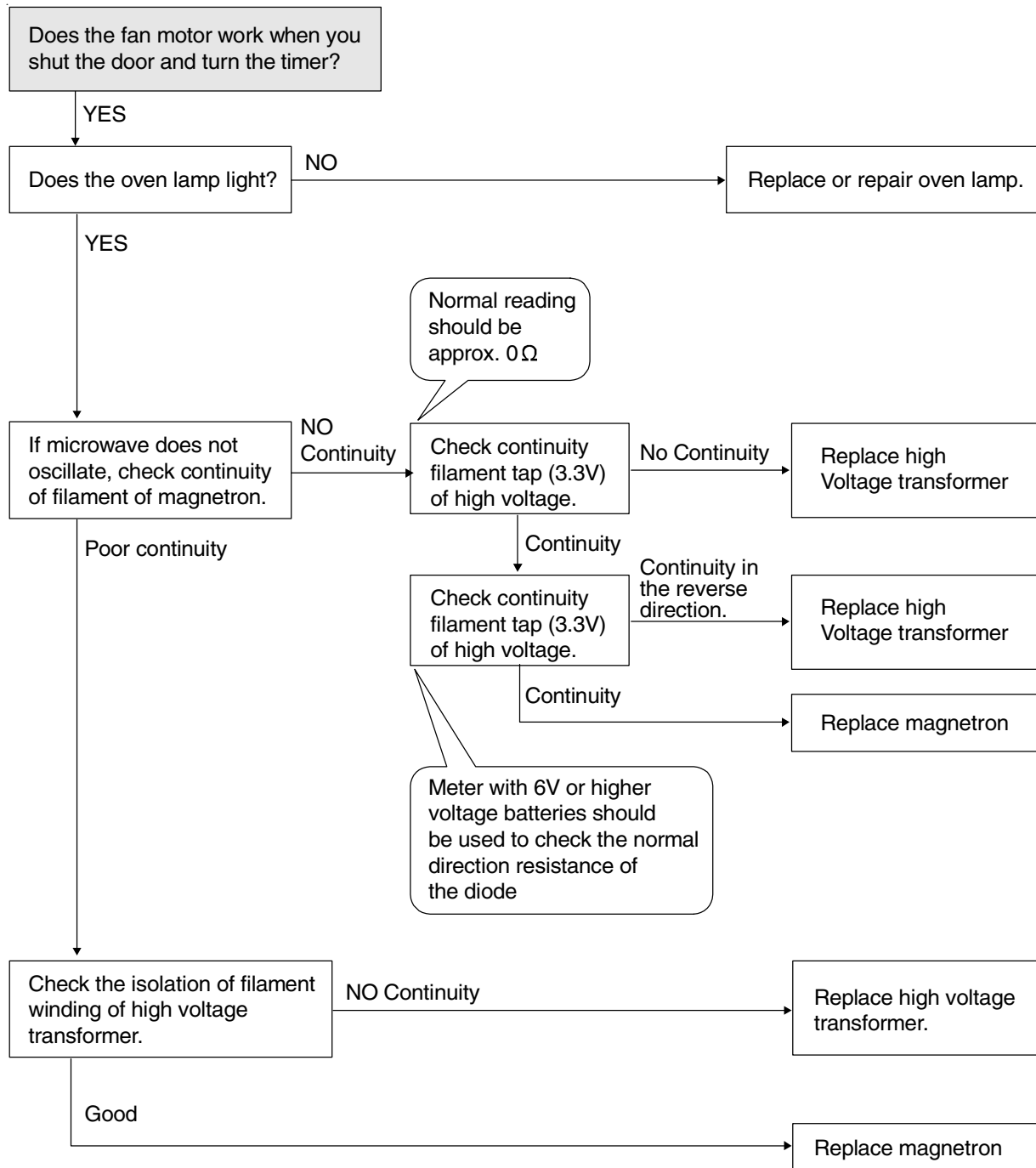

Service Information



WARNING

To avoid risk of electrical shock, personal injury, or death, disconnect power to oven and discharge capacitor before servicing, unless testing requires power.

Proper Handling of Magnetron Tubes



CAUTION

A magnetron tube, like a radio or television tube must be handled with a reasonable amount of care. When handling a tube, always handle by the housing only. Use caution not to touch or strike the ceramic portion at the top. The carton used to ship service replacement tubes is reusable.

Magnetron Failure Modes

Magnetron failures that have been identified are generally grouped into categories shown below.

1. Shorted

Air - This is a case where the tube has had the vacuum envelope destroyed and air has entered the tube. This will cause internal arcing and high secondary current if high voltage is applied.

R.F. Capacitors - May short to chassis. This condition will also cause loss of high voltage.

- 2. Open Heater (Filament)** - Can be determined by a ohmmeter when transformer leads are disconnected. Resistance is normally less than one ohm; filament does not short internally. Any tube removed should be checked since usage tends to make the filament more fragile. Later handling and shipping may open the filament and thereby mask the true failure mode when checked at the factory.
- 3. Low Power** - Caused by "wearout" of the emission characteristics of the directly heated cathode. Symptoms are: (1) tube current will take longer to get to operating point than a new tube (normally about 2 - 3 seconds), (2) tube current does not get high enough to cause the tube to oscillate with normal line voltage, (3) oven produces low power into a load, two-thirds or less than normal.
- 4. Physical Damage** - Caused by mishandling of magnetron tube.

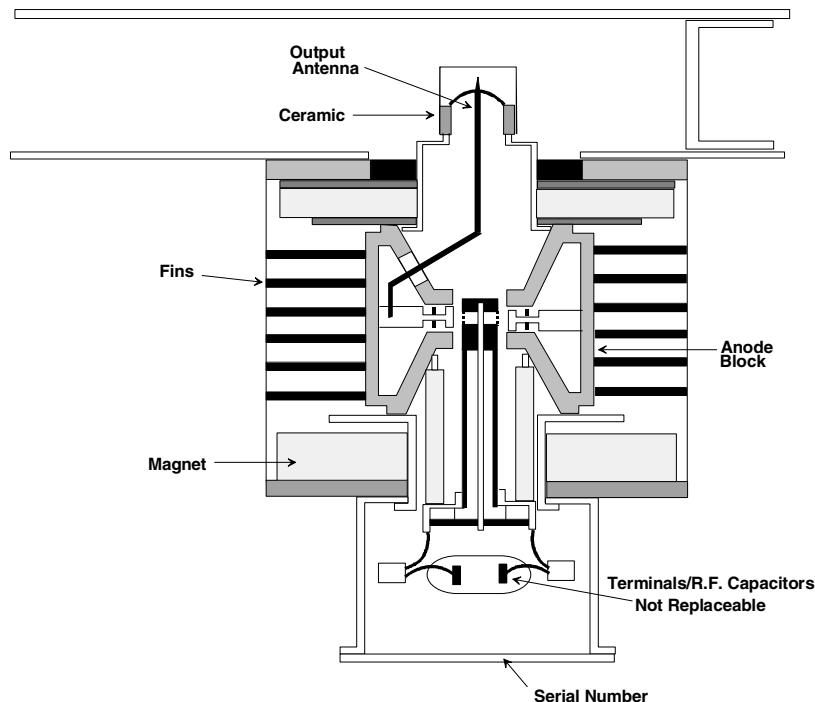

Microwave Leakage Testing



WARNING

To avoid risk of electrical shock, personal injury, or death, disconnect power to oven and discharge capacitor before servicing, unless testing requires power.



WARNING

Check for radiation leakage after servicing. Should the leakage be more than 4 mW/cm² inform Maytag immediately. After repairing or replacing any radiation safety device, keep a written record for future reference, as required by D.H.H.S. and HEW regulations. This requirement must be strictly observed. In addition, the leakage reading must be recorded on the service repair ticket while in the customer's home.

Equipment

- Electromagnetic radiation monitor
- 600 cc glass beaker

Procedure for Measuring Radiation Leakage

Note before measuring:

- Do not exceed meter full scale deflection. Leak monitor should initially be set to the highest scale.
- To prevent false readings the test probe should be held by the grip portion of the handle only.
- The scan speed is equal to one inch per antenna revolution or one inch per second if antenna speed is unknown.
- Areas to be checked are all door seal areas and any venting parts.
- Leakage with the outer panel removed ...4mW/cm² or less.
- Leakage for fully assembled oven with door normally closed ...4 mW/cm² or less.
- Leakage for a fully assembled oven (before the latch switch (primary) is interrupted) while pulling the door ... 4 mW/cm² or less.

1. Pour 275 cc ±15 cc (9 oz ±1/2 oz) of 20°C ± 5°C (68°F ± 9°F) water in a beaker which is graduated to 600 cc and place the beaker in the center of oven.
2. Set the radiation monitor to 2450 MHz and use it following the manufacturer's recommended test procedure to assure correct results.
3. While measuring the leakage, always use the two inch (5 cm) spacer supplied with the probe.
4. Press the start pad or turn on the timer and with the magnetron oscillating, measure the leakage by holding the probe perpendicular to the surface being measured.

Measurement with the Outer Panel Removed



WARNING

Avoid contacting any high voltage components.

Whenever you replace the magnetron, measure for radiation leakage before the outer panel is installed and after all necessary components are replaced or adjusted. Special care should be taken in measuring around the magnetron.

Measurement with a Fully Assembled Oven

After all components including the outer panel are fully assembled, measure for radiation leakage around the door periphery, the door viewing window, the exhaust opening, and air inlet openings.

Record Keeping and Notification After Measurement

1. After any adjustment or repair to a microwave oven, a leakage reading must be taken. Record this leakage reading on the repair ticket even if it is zero.
2. A copy of the repair ticket and the microwave leakage reading should be kept by the repair facility.

Troubleshooting



WARNING

To avoid risk of electrical shock, personal injury, or death, disconnect power to oven and discharge capacitor before servicing, unless testing requires power.

Operating Instructions for the Holaday HI1501, HI1510, and HI1710

Purpose of these monitors is to check radiation leakage around microwave oven door or other places where radiation could possibly occur.

Instrument measures radiation leakage in milliwatts per square centimeters (mW/cm²). Probe should be used with the 2" (5 cm) cone spacer. Water load of 275 cc. (approximately 1 1/3 cup), is to be placed in the oven and used as a load during leakage tests.

Operate the instrument on its internal 9 Volt battery power supply. "Range" switch is used on low and high while using test probe. On an oven with an unknown leakage, use high scale then switch to low scale and test for low leakage. "Bat Test" switch is used to check the battery and probe on the Holaday Instruments. If either is faulty, meter needle will not read above "Test Minimum" or battery mark on meter. Holaday Instrument has a probe test switch position. Meter needle must indicate in the "OK probe test" portion of the scale when in this position. Zero control is used to zero the needle. "ON-OFF" switch provides a means of turning the operating voltage on or off. "Range Multiplier" switch provides a means of selection either 0-2 or 0-10 and 0-100 on the Holaday Instruments sensitivity ranges.

Test probe must be held by the grip portion of the handle, otherwise a false reading may result if operators hand is between the handle and probe.

If oven is likely to have a large amount of leakage, approach oven slowly with the probe, while observing meter. This is achieved by holding the probe two or three feet from oven surface or gap between door and oven body while observing meter. When high leakage is expected, do not move probe horizontally along the oven surface. This could cause possible probe burn-out. Greatest leakage is generally found at the corners. After maximum leakage is established to be within the meter scale range, then probe may be moved horizontally around the door surface.



Hold probe perpendicular to cabinet door. Place cone of probe on the door and/or cabinet door seam and move along the seam. If leakage of the oven is unknown, move probe slowly. Proceed with care in order not to exceed a full scale reading of meter. When testing near a corner or access area of door, keep probe perpendicular to the areas making sure probe end at the base of the cone does not get closer than 2" (5cm) to any metal. If it does, an erroneous reading may result.

Always use the 2" (5cm) spacer with probe. Also, always proceed carefully in areas of high leakage or probe can be accidentally burned-out. Rotating antenna causes high peaks of energy. Although meter has averaging capabilities, probe will react instantaneously to peak power changes which will cause burn-out.

Testing Procedures

⚠ WARNING

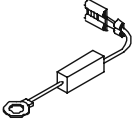
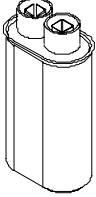
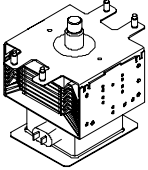
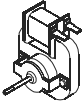
To avoid risk of electrical shock, personal injury or death; disconnect power to oven and discharge capacitor before servicing, unless testing requires power.

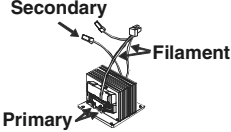
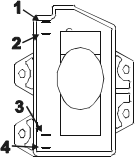
Illustration	Component	Testing	Results
	Thermal cutout	Disconnect all wires from TCO. Measure resistance across terminals. Cavity TCO..... Magnetron TCO.....	Closed at 122°F (50°C) and Opens at 185°F (85°C) Closed at 249°F (115°C) and Opens at 320°F (160°C)
	Diode	Discharge Capacitor Remove diode lead from capacitor and connect ohmmeter. Reverse leads for second test.	Infinite resistance should be measured in one direction and 50KΩ or more in the opposite direction. NOTE: Ohmmeter must contain a battery of 6 volts minimum.
	Capacitor	Discharge Capacitor Remove wires from capacitor terminals and connect ohmmeter, set on highest resistance scale to terminals. Also check between each terminal and capacitor case.	Between Terminals: Meter should momentarily deflect towards zero then return to over 5 MΩ. If no deflection occurs, or if continuous deflection occurs, replace capacitor. Terminal to Case: Infinite resistance
	Magnetron	Discharge Capacitor Remove wires from magnetron and connect ohmmeter to terminals. Also check between each terminal and ground.	Between Terminals: Less than 1 Ω Each terminal to ground measures Infinite resistance. Note: This test is not conclusive. If oven does not heat and all other components test good replace the magnetron and retest.
	Blower motor	Remove all wires from motor. Measure resistance across coil	Approximately 44 Ω
	Stirrer motor	Remove all wires from motor. Measure resistance across terminals	Approximately 3.8K Ω
	Transformer	Discharge Capacitor Remove all wires from terminals. Measure resistance from: Primary Filament Secondary to Ground screw on transformer stack	Less than <1 Ω Less than <1 Ω Approximately 110 Ω
	Dial timer	Remove leads from timer contact terminals. Measure resistance of following terminals: 3 to 4—Timer in OFF position 3 to 4—Timer in ON position 2 to 3—Timer in OFF or ON position	If timer does not indicate readings below, replace timer. Infinite Ω Approximately <1 Ω Approximately 3.3 KΩ (timer motor)
	Lamp and receptacle	Test continuity of receptacle terminals.	Indicates continuity with bulb installed.
	Wire Harness	Test continuity of wires	Indicates continuity
	Electronic control board	Test interlock assembly switches. Test cavity TCO.	If interlock switch assembly and cavity TCO is operating correctly. If the control board still has no display, replace control board.

Testing Procedures



WARNING

To avoid risk of electrical shock, personal injury or death; disconnect power to oven and discharge capacitor before servicing, unless testing requires power.

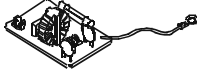
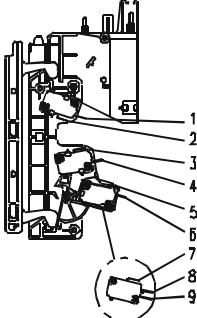
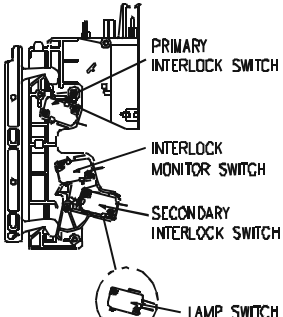
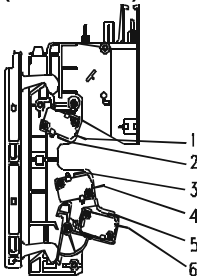
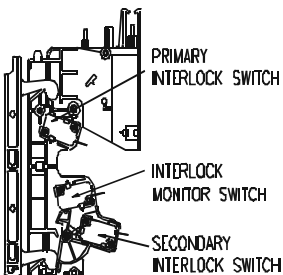
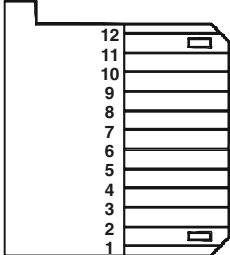
Illustration	Component	Testing	Results																																																						
	Fuse block / Filter assembly	Power In terminals Power Out terminals.....	120 VAC 120 VAC If no power in, check power outlet If no power out, check fuses																																																						
(Electronic) 	Interlock switch assembly 	Disconnect wires to switch. With door open measure resistance from: Monitor – Terminals 3 - 4 Primary – Terminals 1 - 2 Secondary – Terminals 5 - 6 Lamp – Terminals 7 – 8..... Lamp – Terminals 7 – 9..... With door closed measure resistance from: Monitor – Terminals 3 - 4 Primary – Terminals 1 - 2 Secondary – Terminals 5 - 6 Lamp – Terminals 7 – 8..... Lamp – Terminals 7 – 9..... After verifying or replacing the module, re-connect wires to switch and check operation of monitor circuit before operating the oven.	Indicates continuity Infinite Ω Infinite Ω Infinite Ω Indicates continuity Infinite Ω Indicates continuity Indicates continuity Indicates continuity Infinite Ω																																																						
(Mechanical) 	Interlock switch assembly 	Disconnect wires to switch. With door open measure resistance from: Monitor – Terminals 3 - 4 Primary – Terminals 1 - 2 Secondary – Terminals 5 - 6 With door closed measure resistance from: Monitor – Terminals 3 - 4 Primary – Terminals 1 - 2 Secondary – Terminals 5 - 6	Indicates continuity Infinite Ω Infinite Ω Infinite Ω Indicates continuity Indicates continuity																																																						
	Error codes	E-20	Replace Control Board																																																						
Illustration	Component	Testing	Results																																																						
	Keyboard assembly	Continuity is indicated as 100 Ω and below.	<table border="1"> <thead> <tr> <th><u>Pad</u></th> <th><u>Trace</u></th> <th><u>Measurement</u></th> </tr> </thead> <tbody> <tr><td>10.....</td><td>1 & 8</td><td>Continuity</td></tr> <tr><td>9.....</td><td>3 & 9</td><td>Continuity</td></tr> <tr><td>8.....</td><td>2 & 9</td><td>Continuity</td></tr> <tr><td>7.....</td><td>1 & 9</td><td>Continuity</td></tr> <tr><td>6.....</td><td>7 & 8</td><td>Continuity</td></tr> <tr><td>5.....</td><td>6 & 8</td><td>Continuity</td></tr> <tr><td>4.....</td><td>5 & 8</td><td>Continuity</td></tr> <tr><td>3.....</td><td>4 & 8</td><td>Continuity</td></tr> <tr><td>2.....</td><td>3 & 8</td><td>Continuity</td></tr> <tr><td>1.....</td><td>2 & 8</td><td>Continuity</td></tr> <tr><td>STOP/RESET</td><td>4 & 9</td><td>Continuity</td></tr> <tr><td>START/+30 SEC</td><td>5 & 9</td><td>Continuity</td></tr> <tr><td>POWER LEVEL</td><td>6 & 9</td><td>Continuity</td></tr> <tr><td>DEFROST</td><td>7 & 9</td><td>Continuity</td></tr> <tr><td>CHECK PROGRAM ...</td><td>1 & 10</td><td>Continuity</td></tr> <tr><td>PROGRAM.....</td><td>2 & 10</td><td>Continuity</td></tr> <tr><td>QTY 2X</td><td>3 & 10</td><td>Continuity</td></tr> </tbody> </table>	<u>Pad</u>	<u>Trace</u>	<u>Measurement</u>	10.....	1 & 8	Continuity	9.....	3 & 9	Continuity	8.....	2 & 9	Continuity	7.....	1 & 9	Continuity	6.....	7 & 8	Continuity	5.....	6 & 8	Continuity	4.....	5 & 8	Continuity	3.....	4 & 8	Continuity	2.....	3 & 8	Continuity	1.....	2 & 8	Continuity	STOP/RESET	4 & 9	Continuity	START/+30 SEC	5 & 9	Continuity	POWER LEVEL	6 & 9	Continuity	DEFROST	7 & 9	Continuity	CHECK PROGRAM ...	1 & 10	Continuity	PROGRAM.....	2 & 10	Continuity	QTY 2X	3 & 10	Continuity
<u>Pad</u>	<u>Trace</u>	<u>Measurement</u>																																																							
10.....	1 & 8	Continuity																																																							
9.....	3 & 9	Continuity																																																							
8.....	2 & 9	Continuity																																																							
7.....	1 & 9	Continuity																																																							
6.....	7 & 8	Continuity																																																							
5.....	6 & 8	Continuity																																																							
4.....	5 & 8	Continuity																																																							
3.....	4 & 8	Continuity																																																							
2.....	3 & 8	Continuity																																																							
1.....	2 & 8	Continuity																																																							
STOP/RESET	4 & 9	Continuity																																																							
START/+30 SEC	5 & 9	Continuity																																																							
POWER LEVEL	6 & 9	Continuity																																																							
DEFROST	7 & 9	Continuity																																																							
CHECK PROGRAM ...	1 & 10	Continuity																																																							
PROGRAM.....	2 & 10	Continuity																																																							
QTY 2X	3 & 10	Continuity																																																							

Testing Procedures



WARNING

To avoid risk of electrical shock, personal injury or death; disconnect power to oven and discharge capacitor before servicing, unless testing requires power.

All Amana and Menumaster microwave oven power outputs are rated using the IEC705 standards. Using the IEC705 test method requires precision measurements and equipment that is not practical to be performed in the field. Using the test shown below will indicate if the oven performance is satisfactory.

Test equipment required:

- 1000 ml test container and thermometer (Amana power test kit R0157397 Fahrenheit / Menumaster power test kit M95D5 Celsius).
- Digital watch / watch with a second hand for use on ovens with electromechanical timers.

Important Notes:

- Low line voltage will cause low temperature rise / power output.
- Ovens must be on a dedicated circuit, properly grounded, and polarized. Other equipment on the same circuit may cause a low temperature rise / power output.
- This test and results are not a true IEC705 test procedures and are only intended to provide servicers with an easy means of determining if the microwave oven cooking output is correct.

Procedure

1. Fill the test container to the 1000 ml line with cool tap water.

NOTE: Water temperature should be approximately 60°F / 16°C

2. Using the thermometer, stir water for five to ten seconds; measure, and record the temperature (T1).
3. Place test container of water in the center of oven cavity and close door.
4. Heat the water for a 33-second full power cycle.

NOTE: Use a digital watch or a watch with a second hand for ovens with electromechanical timers.

5. At end of the cycle, remove test container. Using the thermometer, stir water for five to ten seconds and record temperature (T2).
6. Subtract the starting water temperature (T1) from the ending water temperature (T2) to obtain the temperature rise (ΔT).
7. If the temperature rise (ΔT) meets or exceeds the minimum, the test is complete. If the temperature rise (ΔT) fails to meet the minimum temperature rise, test the line voltage to verify it is correct. Then repeat steps 1 - 6 making sure to change the water. If the temperature rise (ΔT) fails to meet the minimum temperature rise again the oven will require service.

Minimum Temperature Rise at Thirty -Three (33) Seconds Run Time

ΔT (°F)	Cooking Power Output	ΔT (°F)	Cooking Power Output	ΔT (°C)	Cooking Power Output	ΔT (°C)	Cooking Power Output
10.....	1000	20.....	2000	5.....	1000	11.....	2000
11.....	1100	21.....	2100	5.5.....	1100	11.5.....	2100
12.....	1200	22.....	2200	6.5.....	1200	12.....	2200
14.....	1400	24.....	2400	7.5.....	1400	13.....	2400
17.....	1700	25.....	2500	9.5.....	1700	13.5.....	2500
18.....	1800	27.....	2700	10.....	1800	15.....	2700
19.....	1900	30.....	3000	10.5.....	1900	16.5.....	3000

Disassembly Procedures

WARNING

To avoid the risk of electrical shock, personal injury, or death, disconnect power to oven and discharge the capacitors before following any disassembly procedure.

High voltage is present at the high voltage terminal of the high voltage transformer during any cooking cycle.

It is neither necessary or advisable to attempt measurement of the high voltage.

Before touching any oven components or wiring, always unplug the oven from its power source and discharge capacitor.

Disconnecting Wire Terminals

All wire terminals are locking-type terminals. Proceed as follows to disconnect wire terminals:

Insulated terminals:

Grasp insulator pod and pull back.

DO NOT PULL ON WIRE.

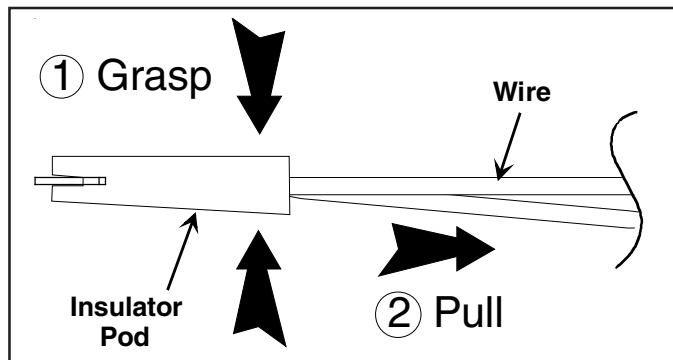

Non-insulated terminals:

Use a small blade screwdriver to depress locking-tab and pull on terminal.

DO NOT PULL ON WIRE.

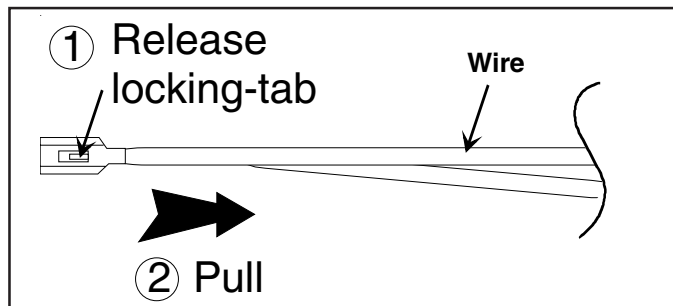

Outer Case

1. Disconnect power to oven.
2. Remove screws securing outer case to unit.
3. Slide outer case towards rear of unit.
4. Reverse procedure to reassemble.

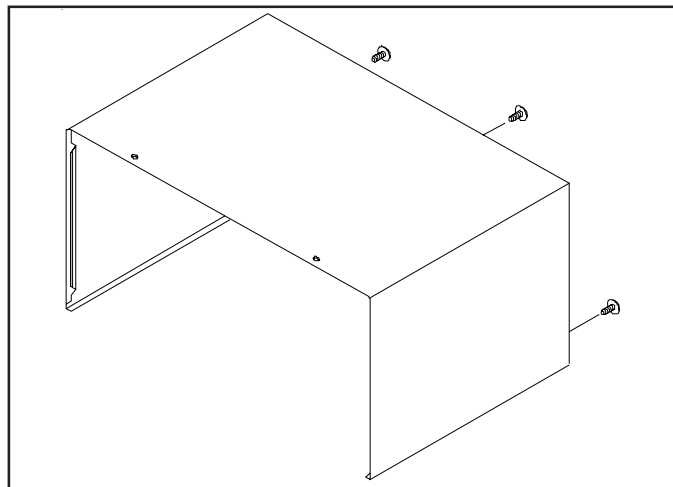

CAUTION

During disassembly some foam gaskets may require removal. These components must be replaced for proper circulation of air over the components and through the oven cavity.

Disassembly Procedures



WARNING

To avoid the risk of electrical shock, personal injury, or death, disconnect power to oven and discharge the capacitors before following any disassembly procedure.

Door Assembly



CAUTION

A microwave leakage test must be performed anytime a door assembly is removed, replaced, disassembled, or adjusted for any reason.

Door Removal

1. Disconnect power to oven.
2. Remove outer case, see "Outer Case" procedure.
3. Remove screws securing top hinge stopper to unit cavity.

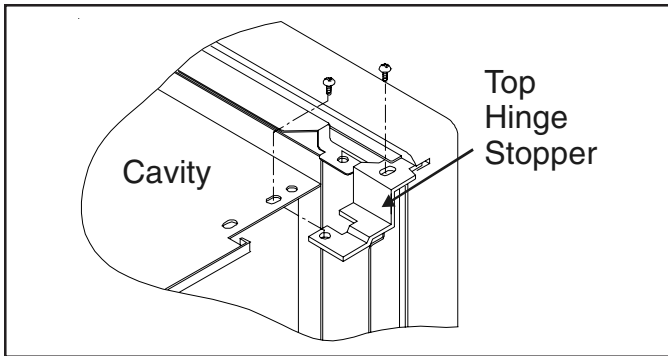

4. Remove oven door assembly from unit.
5. Reassemble in reverse order.

Door Disassembly

1. Disconnect power to oven.
2. Remove oven door, see "Door Removal" procedure.
3. Begin at the bottom of the door near hinge, insert flat blade screwdriver between choke cover and outer door panel. Gently pry upward on choke cover to release tabs. Work in clockwise direction to remove choke cover.



CAUTION

To avoid property damage, care must be taken when prying choke cover from oven door.

4. Slide latch assembly downward and pull away from door frame to release.

5. Remove screws securing choke assembly to outer door panel.

NOTE: When disassembling door, use caution to prevent deformation of slats on door frame/choke assembly.

6. Begin at hinge side of door near bottom, insert flat blade screwdriver between door frame/choke assembly and outer door panel. Gently pry outer door panel away from door frame to release tabs. Work in clockwise direction to remove door frame.
7. Remove spring from hinge assembly.
8. Remove screws securing hinge assembly to choke assembly.
9. Reassemble in reverse order.

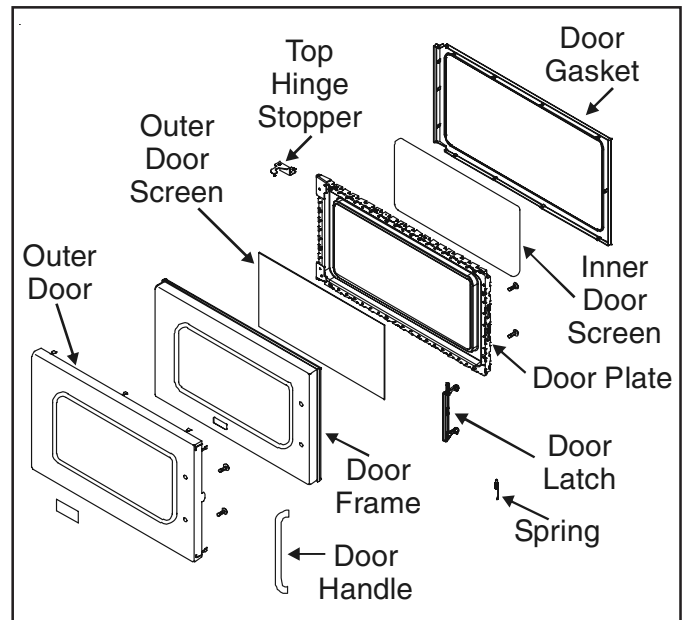

CAUTION

A microwave leakage test must be performed anytime a door assembly is removed, replaced, disassembly, or adjusted for any reason.

Disassembly Procedures

WARNING

To avoid the risk of electrical shock, personal injury, or death, disconnect power to oven and discharge the capacitors before following any disassembly procedure.

Control Panel (Electronic)

1. Disconnect power to oven.
2. Remove outer case, see "Outer Case" procedure.
2. Disconnect and label wires from control board.
3. Open oven door.
4. Remove screw securing control panel to cavity. Lift control panel up and out to release tabs.

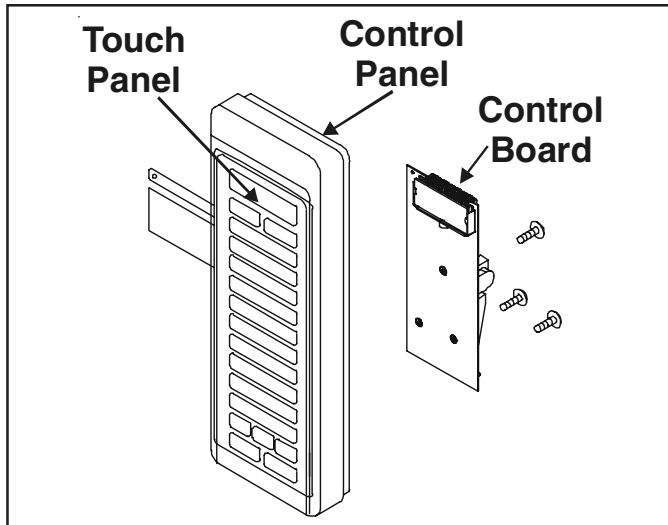

5. Remove screws securing control board to control panel.
6. Replace component and reverse procedure to reassemble.

Control Panel (Mechanical)

1. Disconnect power to oven.
2. Remove outer case, see "Outer Case" procedure.
2. Disconnect and label wires from control.
3. Open oven door.
4. Remove screw securing control panel to cavity. Lift control panel up and out to release tabs.

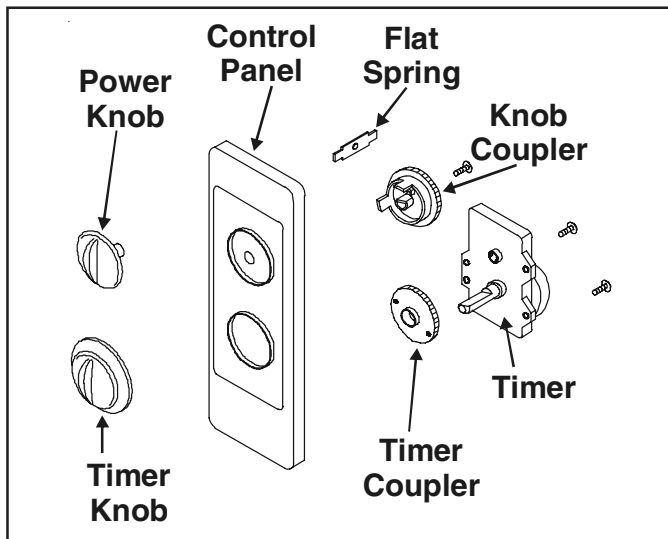

5. Remove timer knob from timer.
6. Remove screws securing timer to control panel and remove timer.
7. Remove timer couple from timer.
8. Remove screw securing knob coupler and flat spring from control panel.
9. Replace component and reverse procedure to reassemble.

Interlock Assembly

Primary switch is operated by the top latch arm.

Interlock Switch Removal

1. Disconnect power to oven and remove outer case, (see "Outer Case" procedure).
2. Remove control panel, (see "Control Panel" section).
3. Remove mounting screws securing interlock switch to unit chassis.
4. Disconnect and label wire connections.

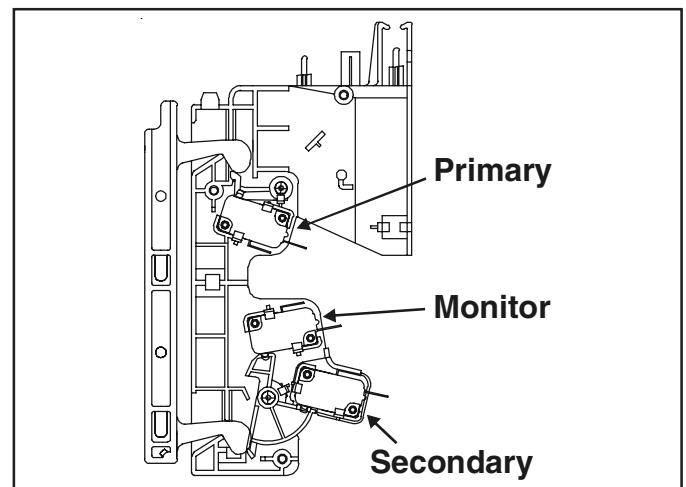

NOTE: After repairing the door or the interlock system, it is necessary to check the switch continuity before operating the oven.

CAUTION

Before replacing a blown monitor fuse, test the primary interlock switch, secondary interlock switch, monitor switch, and power relay contacts for proper operation. If the monitor fuse is blown by a failed switch operation, all switches and controller must be replaced.

Disassembly Procedures



WARNING

To avoid the risk of electrical shock, personal injury, or death, disconnect power to oven and discharge the capacitors before following any disassembly procedure.

Adjusting Interlocks

The interlock monitor, primary, and secondary switches act as a final safety switch, protecting the operator from microwave energy. After adjusting the interlock switch assembly, verify wires are correctly connected.

For door fit and switch operation, switch bracket is adjustable.

1. Disconnect power to oven and remove outer case, (see "Outer Case" procedure).
2. Loosen switch bracket mounting screws.
3. Close oven door, move switch bracket toward rear of oven until door gap is less than $\frac{1}{64}$ -inch (0.5 mm).
4. Hold switch bracket securely for proper switch operation and door fit, retighten screws.
5. Open oven door slowly, watching the switches. Verify switches release in the following order.
 - Primary interlock switch
 - Secondary interlock switch
 - Interlock monitor switch

NOTE: Adjust the switch bracket until all switches operate in proper sequence.

6. Close the oven door slowly, watching the switches. Verify switches activate in the following order.
 - Interlock monitor switch
 - Secondary interlock switch
 - Primary interlock switch
7. When proper switch sequence has been achieved, tighten the switch bracket securely.



CAUTION

A microwave leakage test must be performed anytime a door assembly is removed, replaced, disassembled, or adjustment of switch bracket is performed.

High Voltage Capacitor

High voltage capacitor should always be discharged by shorting a terminal to a chassis ground. The capacitor has a internal "shunt" resistor, but the mechanical discharge should always be performed to avoid personal injury.

High Voltage Capacitor Removal

1. Disconnect power to oven and remove outer case, (see "Outer Case" procedure).
2. Discharge high voltage capacitor.
3. Remove and label wire leads from capacitor terminals.
4. Remove screw securing capacitor strap to bottom plate.
5. Slide capacitor out of capacitor strap and remove capacitor.
6. Replace capacitor and reverse procedure to reassemble.

NOTE: When replacing H.V. components, route H.V. wires at least $\frac{1}{4}$ " from all grounded surfaces to prevent arcing.

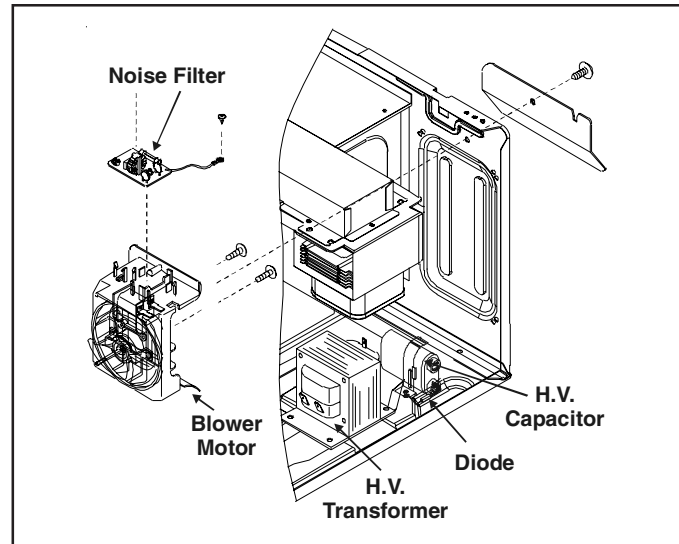

Diode

1. Disconnect power to oven and remove outer case, (see "Outer Case" procedure).
2. Discharge high voltage capacitor, (see "High Voltage Capacitor" section).
3. Disconnect diode from high voltage capacitor and remove screw securing diode to ground.
4. Replace diode and reverse procedure to reassemble.

Disassembly Procedures

WARNING

To avoid the risk of electrical shock, personal injury, or death, disconnect power to oven and discharge the capacitors before following any disassembly procedure.

Transformer

1. Disconnect power to oven and remove outer case, (see "Outer Case" procedure).
2. Discharge high voltage capacitor, (see "High Voltage Capacitor" section).
3. Disconnect and label wire leads from transformer.
4. Place unit on it's back to gain access to mounting screws.
5. Remove screws securing transformer and remove.
6. Replace transformer and reverse procedure to reassemble.

Filter Assembly / Fuse

1. Disconnect power to oven and remove outer case, (see "Outer Case" section).
2. Remove fuse from filter assembly board. See caution below.
3. Disconnect and label wires from filter assembly.
4. Remove screw securing ground wire to chassis.
5. Carefully press tabs to release assembly from locating pin.
6. Replace component(s) and reverse procedure to reassemble.

CAUTION

Before replacing a blown monitor fuse, test the primary interlock switch, secondary interlock switch, monitor switch, and power relay contacts for proper operation. If the monitor fuse is blown by a failed switch operation, all switches and controller must be replaced.

Magnetron

Magnetron is located on the side of the cavity.

1. Disconnect power to oven and remove outer case, (see "Outer Case" section).
2. Discharge high voltage capacitor, (see "High Voltage Capacitor" section).
3. Remove terminal plug from filament terminals.
4. Remove screws securing magnetron cutout bracket to magnetron.
5. Remove screw securing wire support from magnetron.
6. Remove screws securing magnetron to the wave guide.

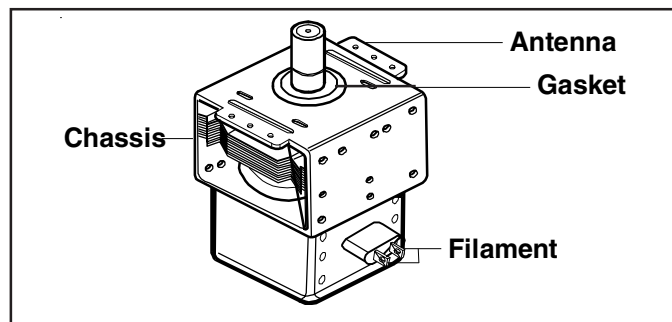

7. Replace magnetron and reverse procedure to reassemble.

NOTE: When replacing magnetron, make sure gasket is in correct position and in good condition.

CAUTION

During replacement of magnetron, be certain the R.F. anode gasket is in place around the anode stud.

WARNING

A microwave leakage test must be performed anytime a magnetron assembly is removed, replaced, disassembled, or adjusted for any reason.

Disassembly Procedures



WARNING

To avoid the risk of electrical shock, personal injury, or death, disconnect power to oven and discharge the capacitors before following any disassembly procedure.

Blower Assembly

1. Disconnect power to oven.
2. Remove outer case, see "Outer Case" procedure.
3. Disconnect wire terminals from blower motor.
4. Remove noise filter board from blower assembly bracket.
5. Remove screws securing vent deflector located on the rear of the unit.
6. Press downward on upper plastic tab securing blower assembly to rear chassis wall.
7. Tilt top portion of blower assembly inward and raise upward to release bottom securing tabs.
8. Replace component and reverse procedure to reassemble.

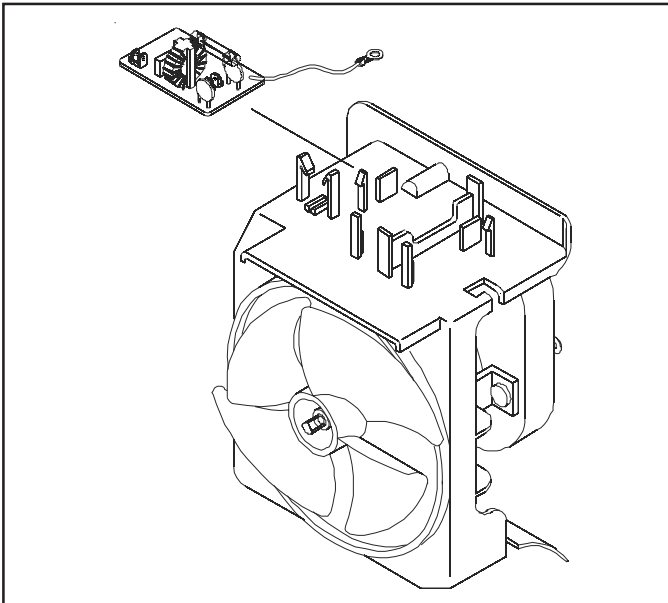

Splatter Shield / Antenna

NOTE: Be careful not to bend antenna when removing splatter shield.

1. Disconnect power to oven.
2. Open oven door to gain access to splatter shield.
3. Remove inner portion of plastic rivet from splatter shield.
4. Remove outer portion of plastic rivet from splatter shield.
5. Slide splatter shield to the right to release tabs securing splatter shield to top of oven cavity.
6. Remove splatter shield from oven cavity.
7. Replace component and reverse procedure to reassemble.

NOTE: When replacing splatter shield, verify motor shaft is aligned with antenna shaft before securing splatter shield.

NOTE: Outer case maybe removed from unit for better visibility in removing splatter shield rivet.

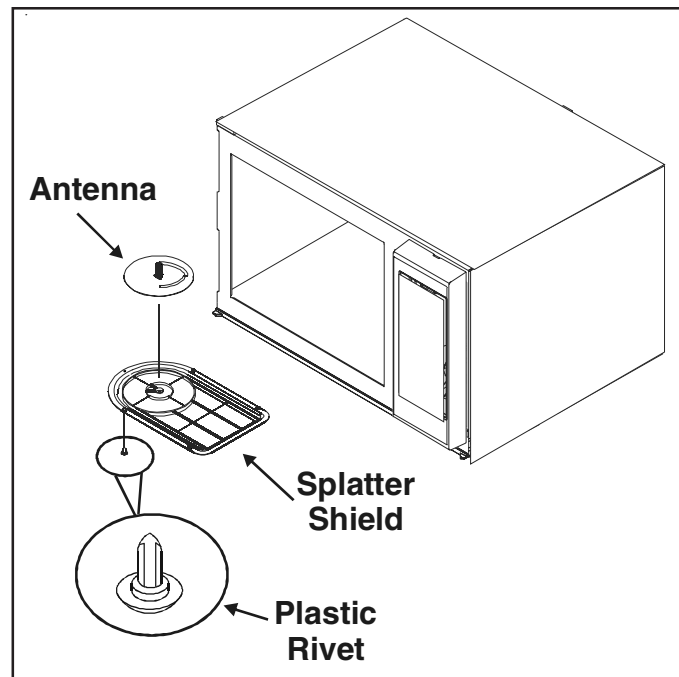

Disassembly Procedures



WARNING

To avoid the risk of electrical shock, personal injury, or death, disconnect power to oven and discharge the capacitors before following any disassembly procedure.

Stirrer Motor

1. Disconnect power to oven.
2. Remove outer case.
3. Disconnect wire terminals from stirrer motor.
4. Remove screws securing stirrer motor to supporting bracket.
5. Replace component and reverse procedure to reassemble.

NOTE: When replacing stirrer motor, verify motor shaft is aligned with antenna shaft before securing with screws.

Magnetron Thermal Cut-Out (Mag TCO)

1. Disconnect power to unit.
2. Remove outer case, see "Outer Case" procedure.
3. Disconnect wire terminals from TCO.
4. Remove screws securing TCO to magnetron.
5. Replace component and reverse procedure to reassemble.

NOTE: When reconnecting wiring to thermal fuses the connectors must be tight.

Cavity Thermal Fuse

1. Disconnect power to unit.
2. Remove outer case, see "Outer Case" procedure.
3. Disconnect wire terminals from thermal fuse.
4. Remove screw securing thermal fuse to oven cavity.
5. Replace component and reverse procedure to reassemble.

NOTE: When reconnecting wiring to thermal fuse the connectors must be tight.

Tray Replacement

1. Unplug oven from outlet.
2. Using a suction cup or a thin bladed screwdriver, pry upward on front corners and remove tray from unit.
3. Thoroughly clean and degrease sump area.
4. Clean oven cavity bottom where new oven tray will make contact using mineral spirits or any nonflammable degreasing solvent.

NOTE: Detergents, soap, and water are not sufficient to remove oil and grease.

5. Place new tray into unit.

Oven Light Assembly

The light bulb for inside of the oven can be changed only by removing the outer case.

Follow these steps to change the bulb:

1. Disconnect power to unit.
2. Remove outer case, see "Outer Case" procedure.
3. Remove interlock assembly, see "Interlock Assembly" procedure steps 1 through 4.
4. Disconnect wire terminals from oven light socket.
5. Push securing tab to release oven light assembly and lift upward to remove from interlock assembly bracket.
6. Replace component and reverse procedure to reassemble.

NOTE: After replacing the oven light assembly. Verify the "Interlock Assembly" is properly aligned and operating correctly.

Air Guide

1. Disconnect power to unit.
2. Remove outer case, see "Outer Case" procedure.
3. Release plastic tabs securing top portion of light cover to inner cavity side wall.
4. Lift upward on light cover to release bottom securing tabs.
5. Replace component and reverse procedure to reassemble.

Appendix A

Dial Model - Quick Reference Guide



Quick Start Reference Guide

Refer to Product Safety Manual for Safety Statements
Complete Owner's Manual available online

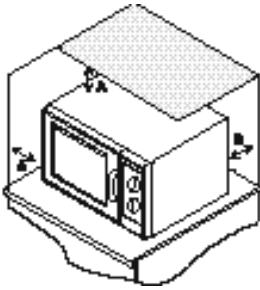

Oven Clearances

- A—Allow at least 2" (5.1 cm) of clearance around top and sides of oven. Proper air flow around oven cools electrical components. With restricted air flow, oven may not operate properly and life of electrical parts is reduced.
- B—Allow at least 2" (5.1 cm) between air discharge on back of oven and back wall.

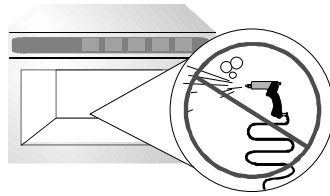

DO NOT power spray

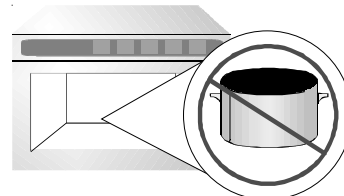

No metal pans

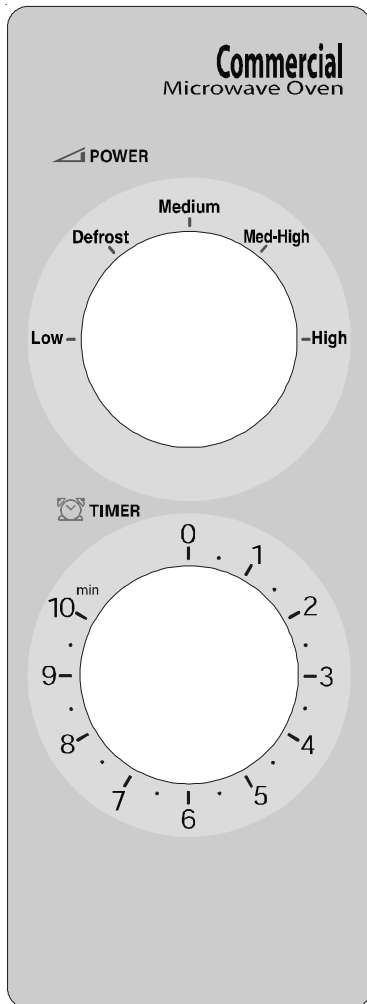

So...how do I use it?

Heating

1. Open oven door, place food in oven, and close oven door.
2. Turn the power level knob to desired power level.
 - Power level can be set at Low (17%), Defrost (33%), Medium (55%), Med. High (77%), or High power (100%).
3. Turn time entry knob clockwise until desired time displays.
 - Cooking time can be set up to 10 minutes.
 - If turning the timer knob for less than 2 minutes, turn it past 2 minutes and then back to the desired time.
4. Oven begins operation and time counts down.
5. When cooking time elapsed, microwave energy stops and oven signal sounds.

Interrupting Operation

Open oven door to interrupt operation or turn time entry knob counterclockwise to "0". To resume microwave oven operation, close oven door. If time was changed to "0", time will need to be reset.

Changing Time and Power/Canceling Mistakes

Cooking time and power level can be changed at any time while the oven is operating. Turn knob(s) to desired new setting. To set cooking time to zero, turn time entry knob counterclockwise to "0".



Electronic Model - Quick Reference Guide



Quick Start Reference Guide

Refer to Product Safety Manual for Safety Statements

Complete Owner's Manual available online

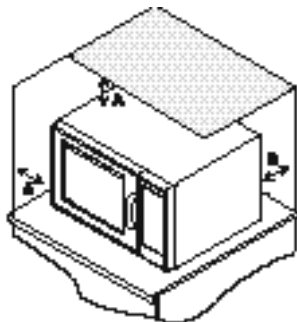

Oven Clearances

A—Allow at least 2" (5.1 cm) of clearance around top and sides of oven. Proper air flow around oven cools electrical components. With restricted air flow, oven may not operate properly and life of electrical parts is reduced.
B—Allow at least 2" (5.1 cm) between air discharge on back of oven and back wall.

So...how do I use it?

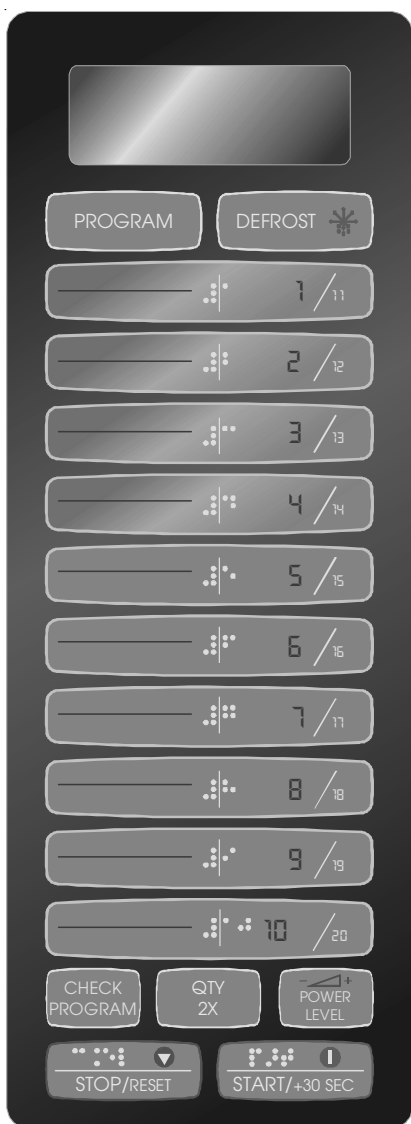

Manual Operation

To cook food using a specific entered time and power level:

1. Open oven door and place food in oven. Close door.
2. Press POWER LEVEL pad until desired power level is shown.
3. Press the number pad(s) to enter a cooking time.
4. Press START pad.
5. At end of cooking cycle oven beeps 3 times and shuts off.

Programming Items

This microwave oven has 20 programmable pads (1-20).

NOTE: Only pads 1-10 are preprogrammed at the factory.

1. Press PROGRAM pad.
 - **PROGRAM** shows in the display.
2. Press the number pad to be reprogrammed. (ex. pad 5)
 - **PROG--05** shows in the display.
 - To program pads 11-20, press number pad twice rapidly. (ex. To program pad 15, press pad 5 twice rapidly.)
3. Press POWER LEVEL pad to select desired power level.
 - Power level is displayed. For less than 100%, press POWER pad again until desired power level is shown.
4. Press the number pad(s) to enter a cooking time.
5. Press START pad to save new programming changes.
 - **STAGE-2** shows in the display and a long beep sounds.
6. Repeat steps 3-5 to program in stage two or three.
 - After touching START pad to save new programming changes in 2 stage, **STAGE-3** shows in the display.
 - After touching START pad to save new programming changes in 3 stage, **--END--** shows in the display.
 - Up to three different stages can be programmed.
7. Press STOP/RESET pad to save programming changes.
 - Programming function ends.

Electronic Model - Quick Reference Guide

Quick Start Reference Guide

Refer to Product Safety Manual for Safety Statements

Complete Owner's Manual available online

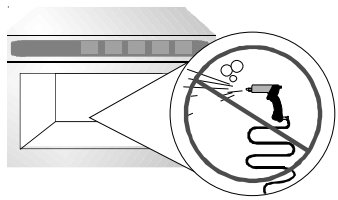

DO NOT power spray

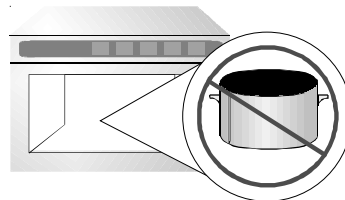

No metal pans



Defrost Pad

To defrost food by dividing the defrost time into periods of alternating defrost and stand times by cycling on and off:

1. Open oven door and place food in oven. Close door.
2. Press DEFROST pad.
 - DEFROST indicator lights and :0 shows in the display.
3. Press the number pad(s) to enter the desired defrosting time.
4. Press START pad.
5. Oven begins to cycle.
 - The display counts down the time to show you how much defrosting time is left in the DEFROST mode.

NOTE: Oven beeps during the defrosting cycle to signal that the food needs to be turned or rearranged.

6. Open door and rearrange food.
7. Close door.
8. Press START pad to continue defrost cycle.

NOTE: If you don't open door to rearrange food, defrost cycle continues.



Preprogrammed Pads

(example of pad 5 shown)

To cook food using preprogrammed cooking sequences:

1. Open oven door and place food in oven. Close door.
2. Press the number pad(s) to enter a cooking time.
3. Oven begins to cook.
4. At end of cooking cycle, oven beeps 3 times and shuts off.



Check Program Pad

To check the programmed cooking time and power level:

1. Press CHECK PROGRAM pad.
 - **CHECK** shows in the display.
2. Press the number pad(s) which you want to confirm. (ex. pad 5)
 - **PROG--05** will show in the display and then the cooking time and power level for each stage.
3. Press STOP/RESET pad to end the check function.



QTY 2X Pad

To temporarily extend programmed cooking time by twice:

1. Open oven door and place food in oven. Close door.
2. Press QTY 2X pad.
 - **DOUBLE** shows in the display.
3. Press desired preprogrammed pad. (ex. pad 5)
 - **PROG--05** will show in the display.
4. Oven begins cooking.

NOTE: Maximum cooking time is 59 minutes 99 seconds except while using full power. In case of full power (100%), maximum cooking time is 20 minutes 00 seconds.



+30 SEC Pad

To reheat food for 30 second intervals at 100% power:

1. Press +30 SEC pad.
 - **:30** shows in the display.
2. Oven begins to cook.

NOTE: By repeatedly touching the +30 SEC pad, you can also extend the reheating time to a total of 5 minutes, in 30 second increments.