

Vector[®] Multi-Cook Oven

Deluxe Control

VMC-H2	VMC-H2H
VMC-H3	VMC-H3H
VMC-H4	VMC-H4H



Structured Air Technology™

Manufacturer's Information

Copyright © Copyright 07/2021 by Alto-Shaam, Inc.
 All rights reserved.
 This manual or any portion thereof may not be reproduced or used in any manner whatsoever without the express written permission of Alto-Shaam, Inc

Trademarks All trademarks referenced in this documentation are the property of their respective owners.

Manufacturer Alto-Shaam, Inc.
 P.O. Box 450
 W164 N9221 Water Street
 Menomonee Falls, WI 53052

Models Covered

<p>Half-Size Sheet Pan Models VMC-H2 VMC-H3 VMC-H4 Hotel Pan Models VMC-H2H VMC-H3H VMC-H4H</p>	<p>RH - Right-Hand Swing Door LH - Left-Hand Swing Door US (UL Certified) Models International (CE Certified) Models</p>
--	---

Serial Number The unit serial number is required for ordering the correct service parts.
 Record the unit serial number in the space provided below.

Serial Number

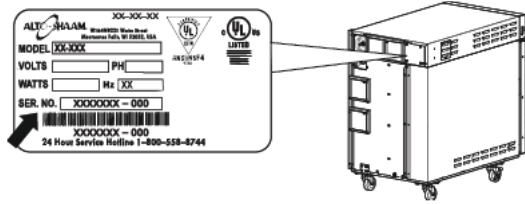

Parts Ordering Information Original manufacturer's replacement parts may be ordered directly from the Alto-Shaam network of Authorized Service Agents and Parts Distributors. Follow this link for a map to a local partner: <https://www.alto-shaam.com/en/how-to-buy>. If you are an Authorized Service Agent or Parts Distributor, please submit your purchase order to parts@alto-shaam.com.

Non-OEM parts may be substituted; however, these parts must be of equal quality and specifications as those provided by Alto-Shaam.

Table of Contents

Manufacturer’s Information	2	Core Components, H3H (LH)	38
Table of Contents	3	Core Components, H4 (RH).....	39
Panel Assembly, H2 (RH).....	4	Core Components, H4 (LH)	40
Panel Assembly, H2 (LH).....	5	Core Components, H4H (RH).....	41
Panel Assembly, H2H (RH).....	6	Core Components, H4H (LH)	42
Panel Assembly, H2H (LH).....	7	Motor/Fan Assembly (All Models)	43
Panel Assembly, H3 (RH).....	8	Casters and Feet.....	44
Panel Assembly, H3 (LH).....	9	Casters and Feet: Where Used	45
Panel Assembly, H3H (RH).....	10		
Panel Assembly, H3H (LH).....	11		
Panel Assembly, H4 (RH).....	12		
Panel Assembly, H4 (LH).....	13		
Panel Assembly, H4H (RH).....	14		
Panel Assembly, H4H (LH).....	15		
Door Assembly, Right, H2/H2H.....	16		
Door Assembly, Left, H2/H2H	17		
Door Assembly, Right, H3/H3H.....	18		
Door Assembly, Left, H3/H3H	19		
Door Assembly, Right, H4/H4H.....	20		
Door Assembly, Left, H4/H4H	21		
Control Panel, All Models	22		
Electrical Chassis, H2/H2H, 208-240V, 60Hz, 1PH	23		
Electrical Chassis, H2/H2H, 220-240V, 50/60Hz, 1PH CE	24		
Electrical Chassis, H2/H2H, 380-415V, 50/60Hz, 3PH CE	25		
Electrical Chassis, H3/H3H, 208-240V, 60Hz, 1PH	26		
Electrical Chassis, H3/H3H, 208-240V, 60Hz, 3PH	27		
Electrical Chassis, H3/H3H, 380-415V, 50/60Hz, 3PH CE	28		
Electrical Chassis, H4/H4H, 220-240V, 60Hz, 3PH	29		
Electrical Chassis, H4/H4H, 380-415V, 50/60Hz, 3PH CE	30		
Core Components, H2 (RH)	31		
Core Components, H2 (LH).....	32		
Core Components, H2H (RH)	33		
Core Components, H2H (LH).....	34		
Core Components, H3 (RH)	35		
Core Components, H3 (LH).....	36		
Core Components, H3H (RH)	37		

Panel Assembly, H2 (RH)

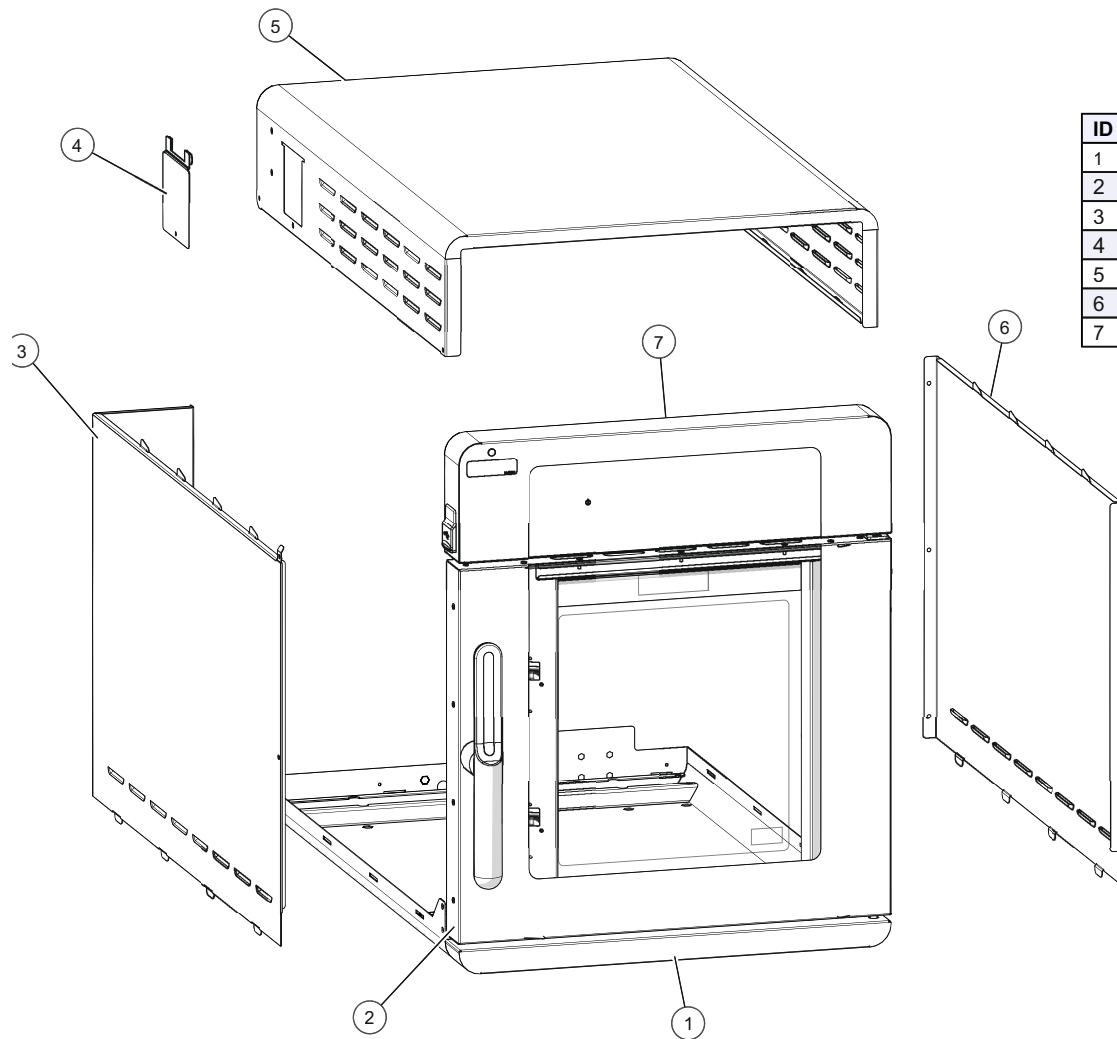

ID	Part No.	Description
1	1028088	DOOR, FILLER, VOLPI H
2	5028748	DOOR ASSEMBLY VH2R DX
3	1029173	SKIN, LEFT SIDE, VOLPI H2
4	1028087	DOOR, BREAKER, VOLPI H
5	1028905	SKIN, TOP, VOLPI H
6	1029172	SKIN, RIGHT SIDE, VOLPI H2
7	5028218	DX CONTROL PANEL

Panel Assembly, H2 (LH)

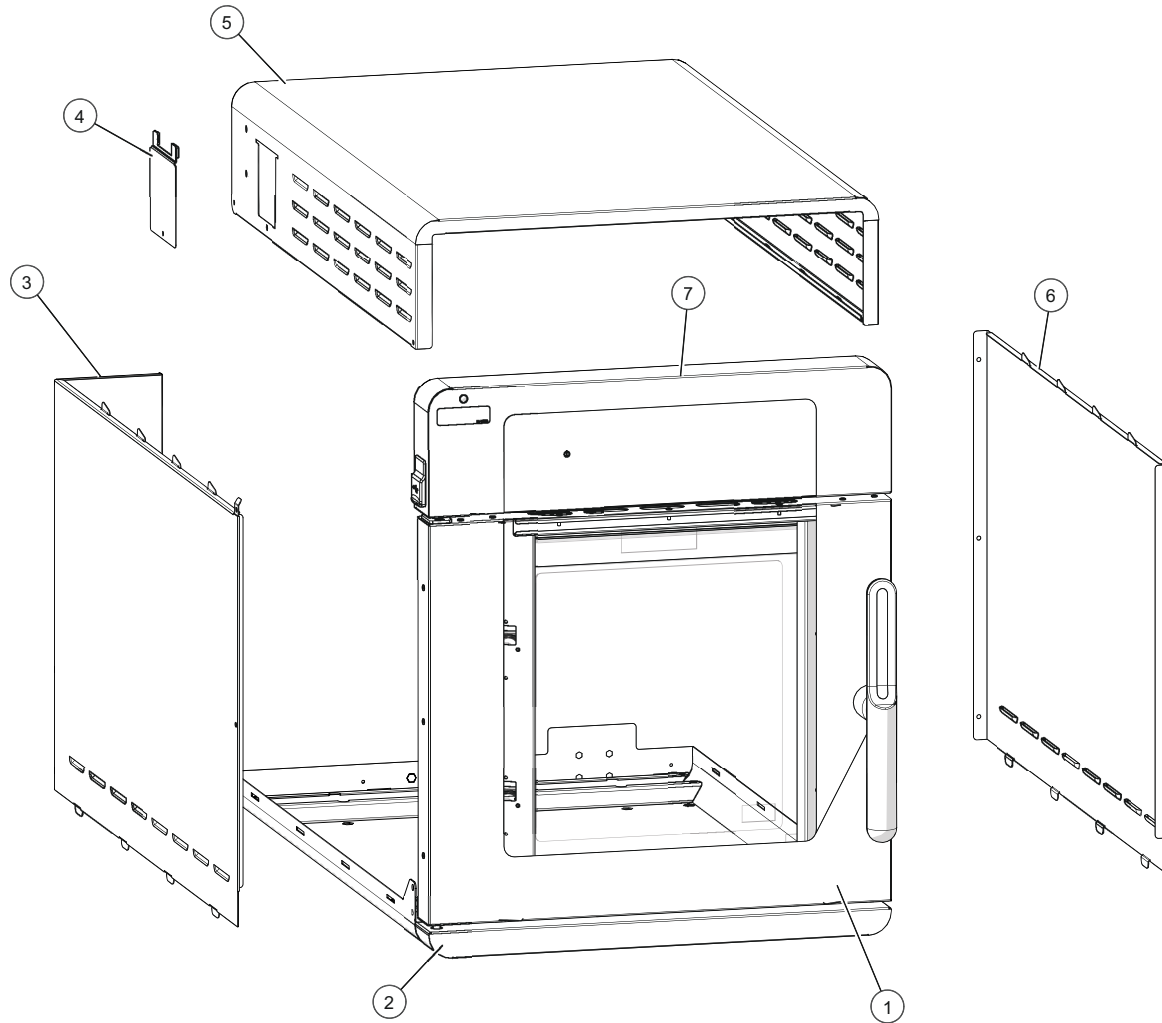

ID	Part No.	Description
1	5028787	DOOR ASSEMBLY VH2L DX
2	1028873	DOOR, FILLER, VOLPI H
3	1029173	SKIN, LEFT SIDE, VOLPI H2
4	1028087	DOOR, BREAKER, VOLPI H
5	1028905	SKIN, TOP, VOLPI H
6	1029172	SKIN, RIGHT SIDE, VOLPI H2
7	5028218	CONTROL PKG H SERIES DELUXE

Panel Assembly, H2H (RH)

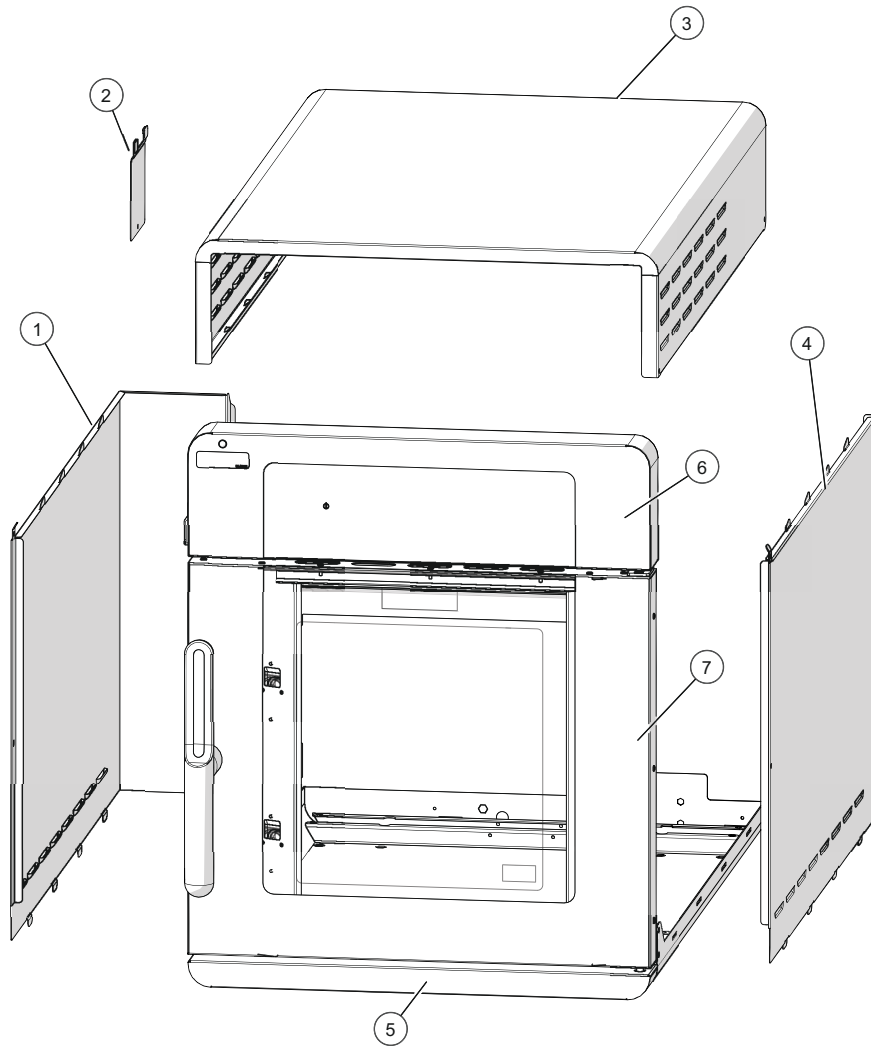

ID	Part No.	Description
1	1029219	SKIN, LEFT SIDE, VOLPI H2
2	1028087	DOOR, BREAKER, VOLPI H
3	1028086	SKIN, TOP, VOLPI HOTEL VMC
4	1029218	SKIN, RIGHT SIDE, VOLPI H2
5	1028088	DOOR, FILLER, VOLPI H
6	5028218	DX CONTROL PANEL
7	5028748	DOOR ASSEMBLY VH2R DX

Panel Assembly, H2H (LH)

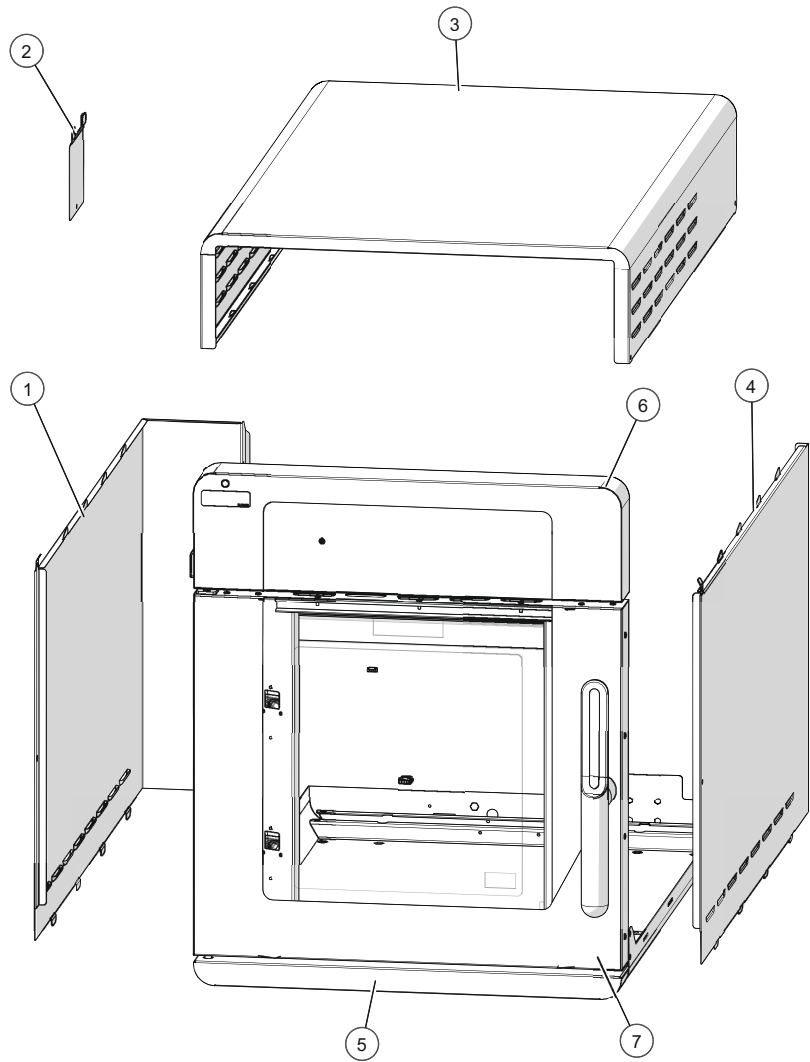

ID	Part No.	Description
1	1029219	SKIN, LEFT SIDE, VOLPI H2
2	1028087	DOOR, BREAKER, VOLPI H
3	1028086	SKIN, TOP, VOLPI HOTEL VMC
4	1029218	SKIN, RIGHT SIDE, VOLPI H2
5	1028873	DOOR, FILLER, VOLPI H
6	5028218	DX CONTROL PANEL
7	5028787	DOOR ASSEMBLY VH2L DX

Panel Assembly, H3 (RH)

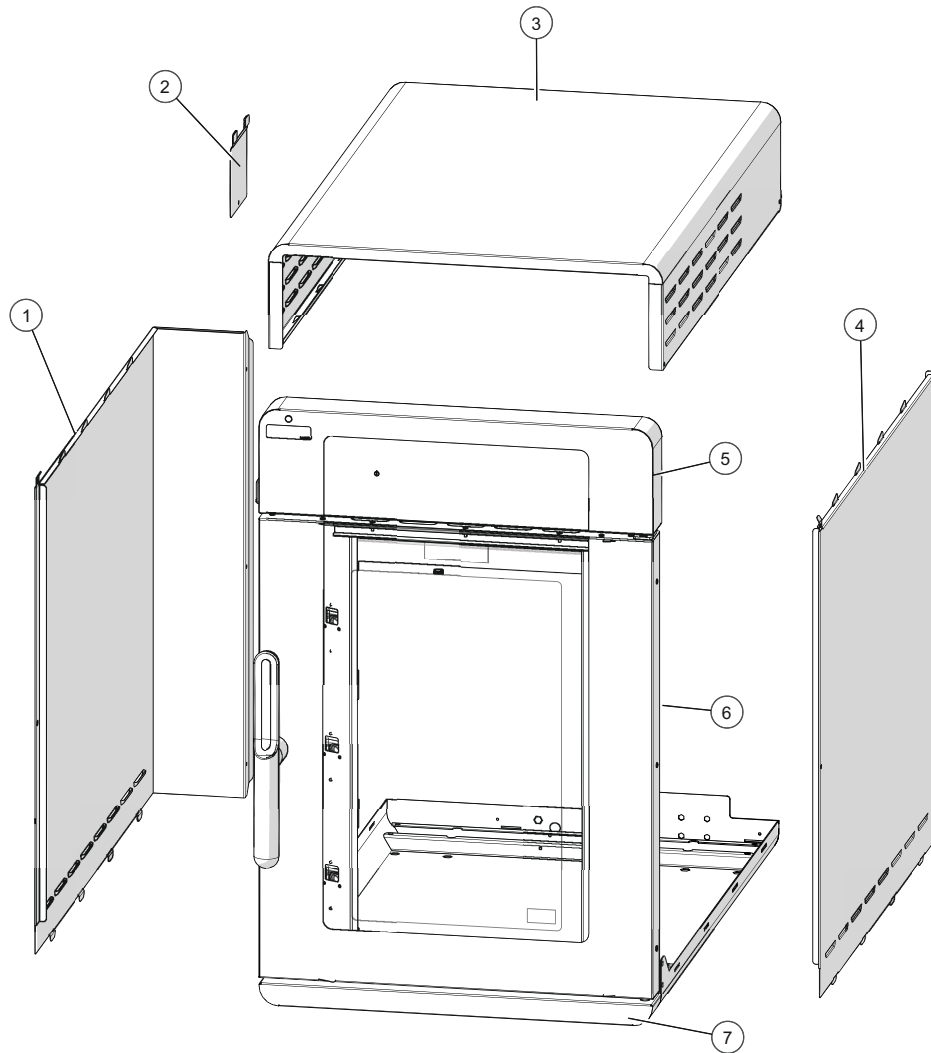

ID	Part No.	Description
1	1028903	SKIN, LEFT SIDE, VOLPI H3
2	1028087	DOOR, BREAKER, VOLPI H
3	1028905	SKIN, TOP, VOLPI H
4	1028904	SKIN, RIGHT SIDE, VOLPI H3
5	5028218	DELUXE CONTROL PANEL
6	5028736	DOOR ASSEMBLY VH3R DX
7	1028088	DOOR, FILLER, VOLPI H

Panel Assembly, H3 (LH)

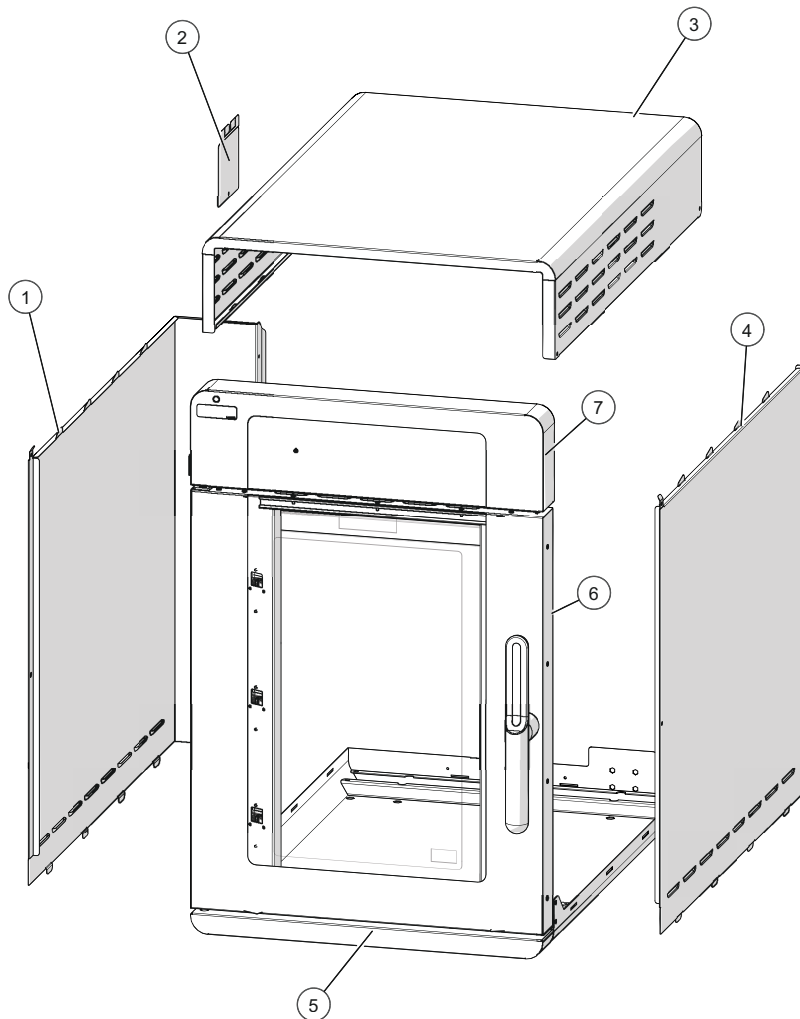

ID	Part No.	Description
1	1028903	SKIN, LEFT SIDE, H3
2	1028087	DOOR, BREAKER, VOLPI H
3	1028905	SKIN, TOP, VOLPI H
4	1028904	SKIN, RIGHT SIDE, H3
5	1028873	DOOR, FILLER, VOLPI H
6	5028782	DOOR ASSEMBLY VH3L DX
7	5028218	DELUXE CONTROL PANEL

Panel Assembly, H3H (RH)

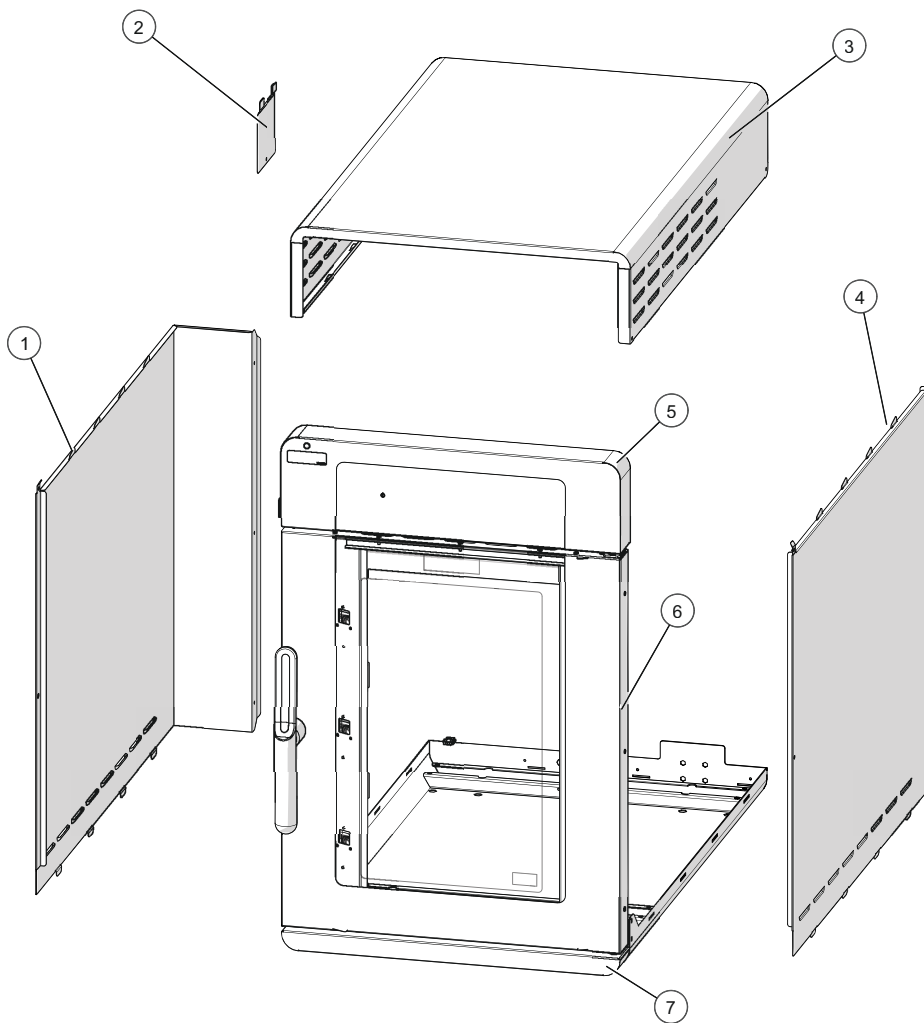

ID	Part No.	Description
1	1028093	SKIN, LEFT SIDE, VOLPI H3
2	1028087	DOOR, BREAKER, VOLPI H
3	1028086	SKIN, TOP, VOLPI HOTEL VMC
4	1028092	SKIN, RIGHT SIDE, VOLPI H3
5	5028218	DELUXE CONTROL PANEL
6	5028736	DOOR ASSEMBLY VH3R DX
7	1028088	DOOR, FILLER, VOLPI H

Panel Assembly, H3H (LH)

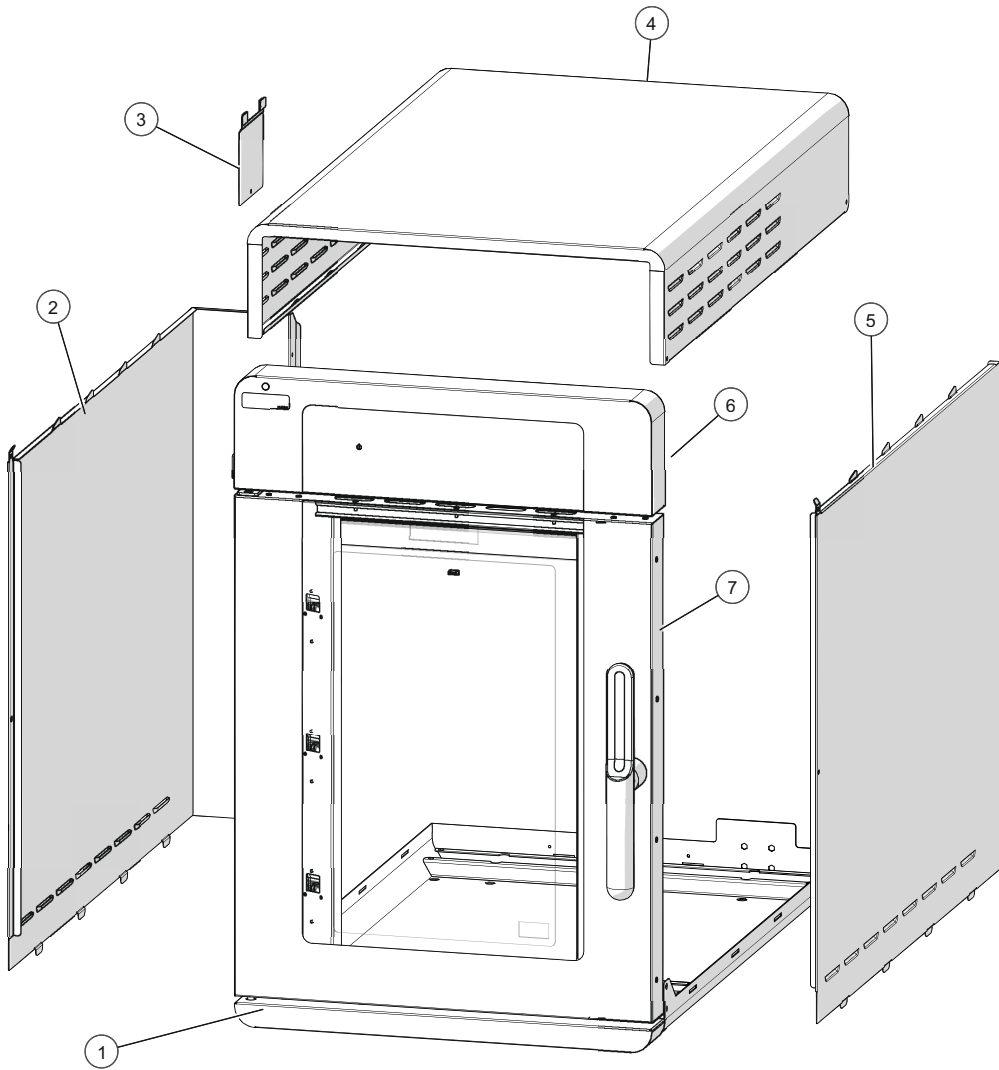

ID	Part No.	Description
1	1028873	DOOR, FILLER, VOLPI H
2	1028093	SKIN, LEFT SIDE, VOLPI H3
3	1028087	DOOR, BREAKER, VOLPI H
4	1028086	SKIN, TOP, VOLPI HOTEL VMC
5	1028092	SKIN, RIGHT SIDE, VOLPI H3
6	5028218	DX CONTROL PANEL
7	5028782	DOOR ASSEMBLY VH3L DX

Panel Assembly, H4 (RH)

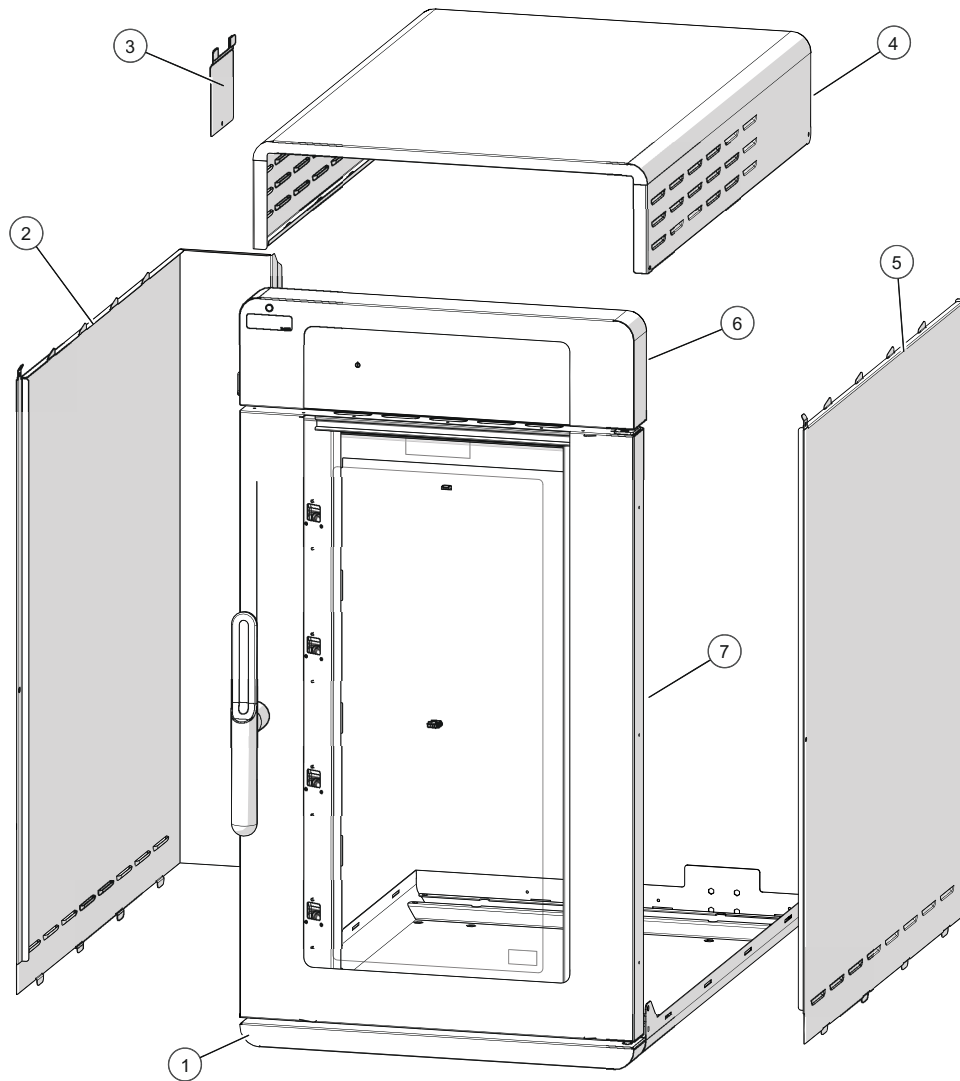

ID	Part No.	Description
1	1028088	DOOR, FILLER, VOLPI H
2	1028914	SKIN, LEFT SIDE, VOLPI H4
3	1028087	DOOR, BREAKER, VOLPI H
4	1028905	SKIN, TOP, VOLPI H
5	1028913	SKIN, RIGHT SIDE, VOLPI H4
6	5028218	DX CONTROL PANEL
7	5028534	DOOR ASSEMBLY VH4R DX

Panel Assembly, H4 (LH)

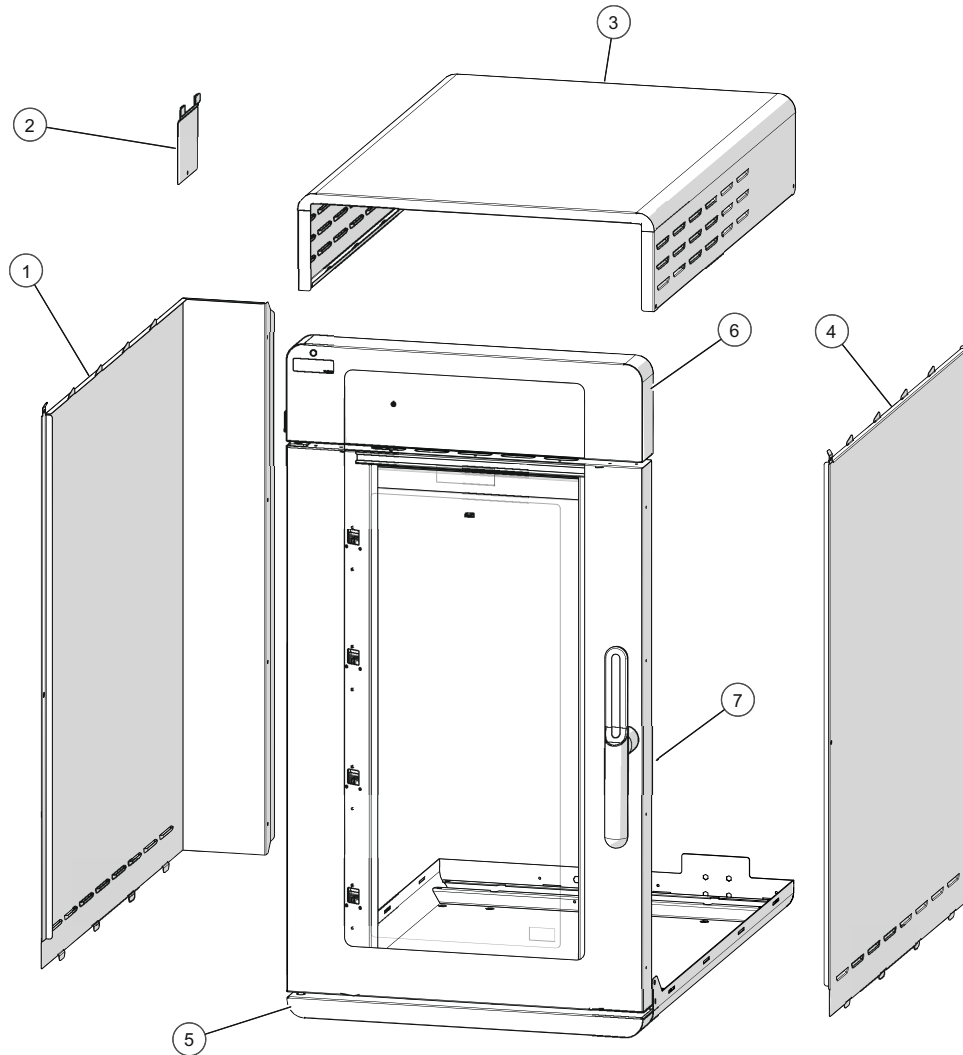

ID	Part No.	Description
1	1028914	SKIN, LEFT SIDE, VOLPI H4
2	1028087	DOOR, BREAKER, VOLPI H
3	1028905	SKIN, TOP, VOLPI H
4	1028913	SKIN, RIGHT SIDE, VOLPI H4
5	1028873	DOOR, FILLER, VOLPI H
6	5028218	DX CONTROL PANEL
7	5028613	DOOR ASSEMBLY VH4L DX

Panel Assembly, H4H (RH)

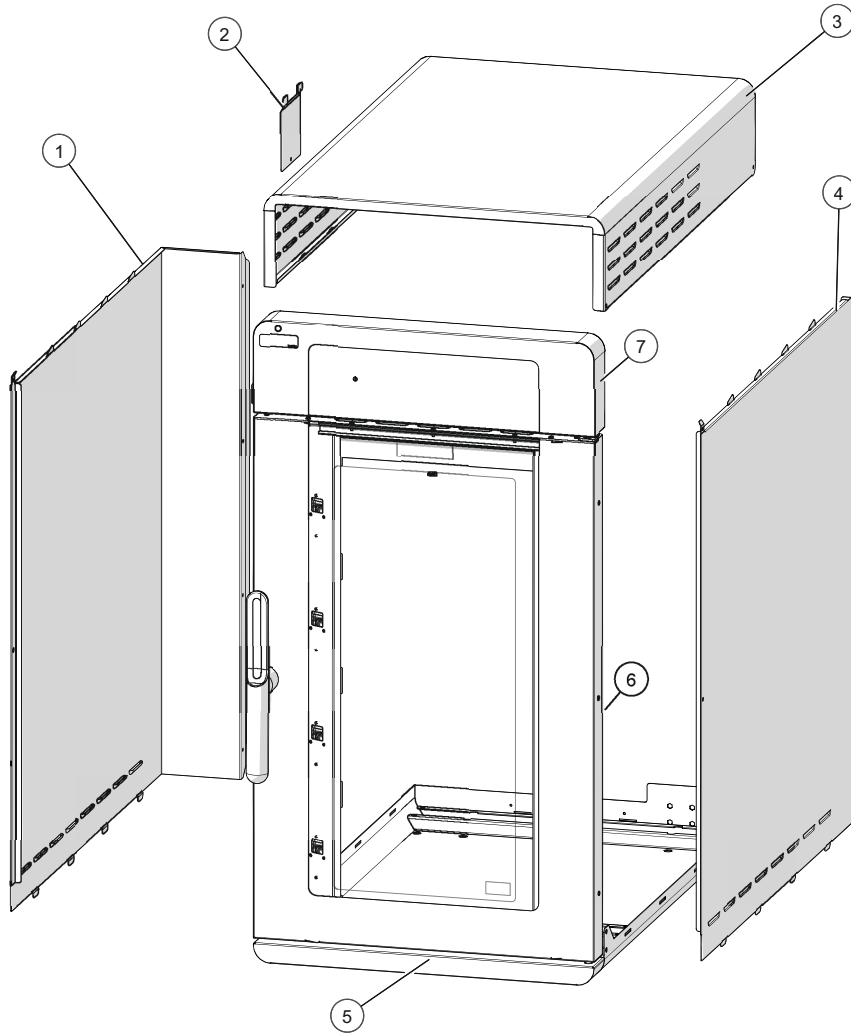

ID	Part No.	Description
1	1029100	SKIN, LEFT SIDE, H4H
2	1028087	DOOR, BREAKER, VOLPI H
3	1028086	SKIN, TOP, VOLPI HOTEL VMC
4	1029099	SKIN, RIGHT SIDE, H4H
5	1028088	DOOR, FILLER, VOLPI H
6	5028534	DOOR ASSEMBLY VH4R DX
7	5028218	DELUXE CONTROL PANEL

Panel Assembly, H4H (LH)

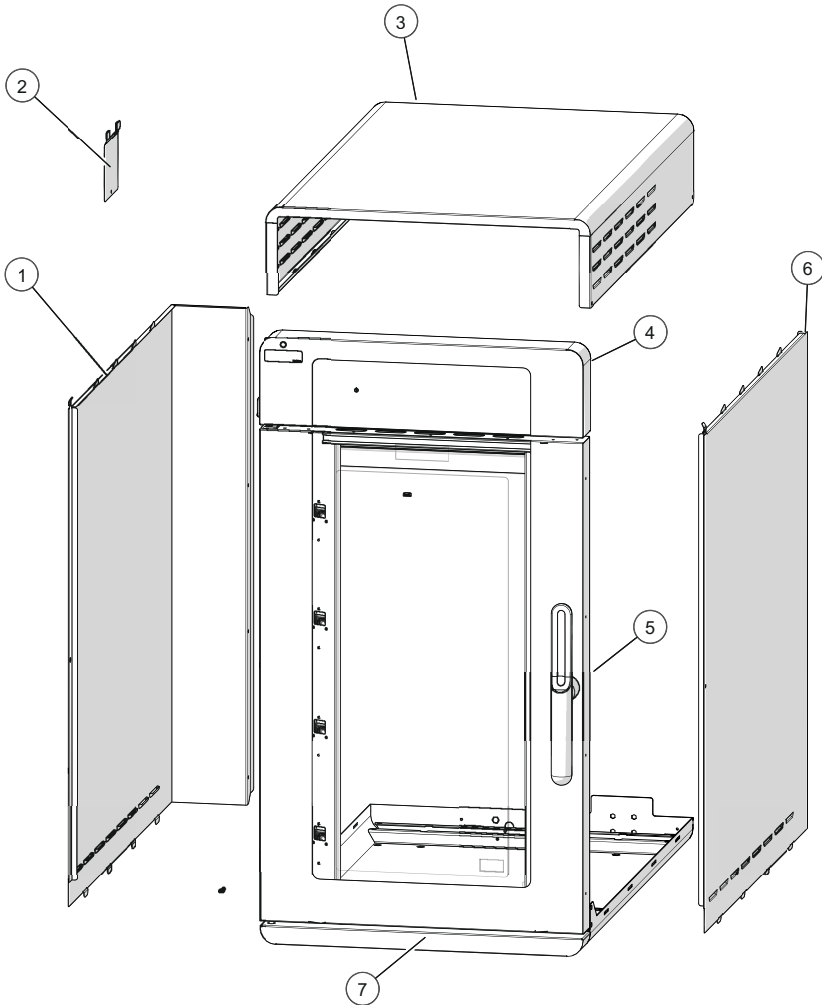

ID	Part No.	Description
1	1029100	SKIN, LEFT SIDE, H4H
2	1028087	DOOR, BREAKER, VOLPI H
3	1028086	SKIN, TOP, VOLPI HOTEL VMC
4	5028218	DELUXE CONTROL PANEL
5	5028613	DOOR ASSEMBLY VH4L DX
6	1029099	SKIN, RIGHT SIDE, H4H
7	1028873	DOOR, FILLER, VOLPI H

Door Assembly, Right, H2/H2H

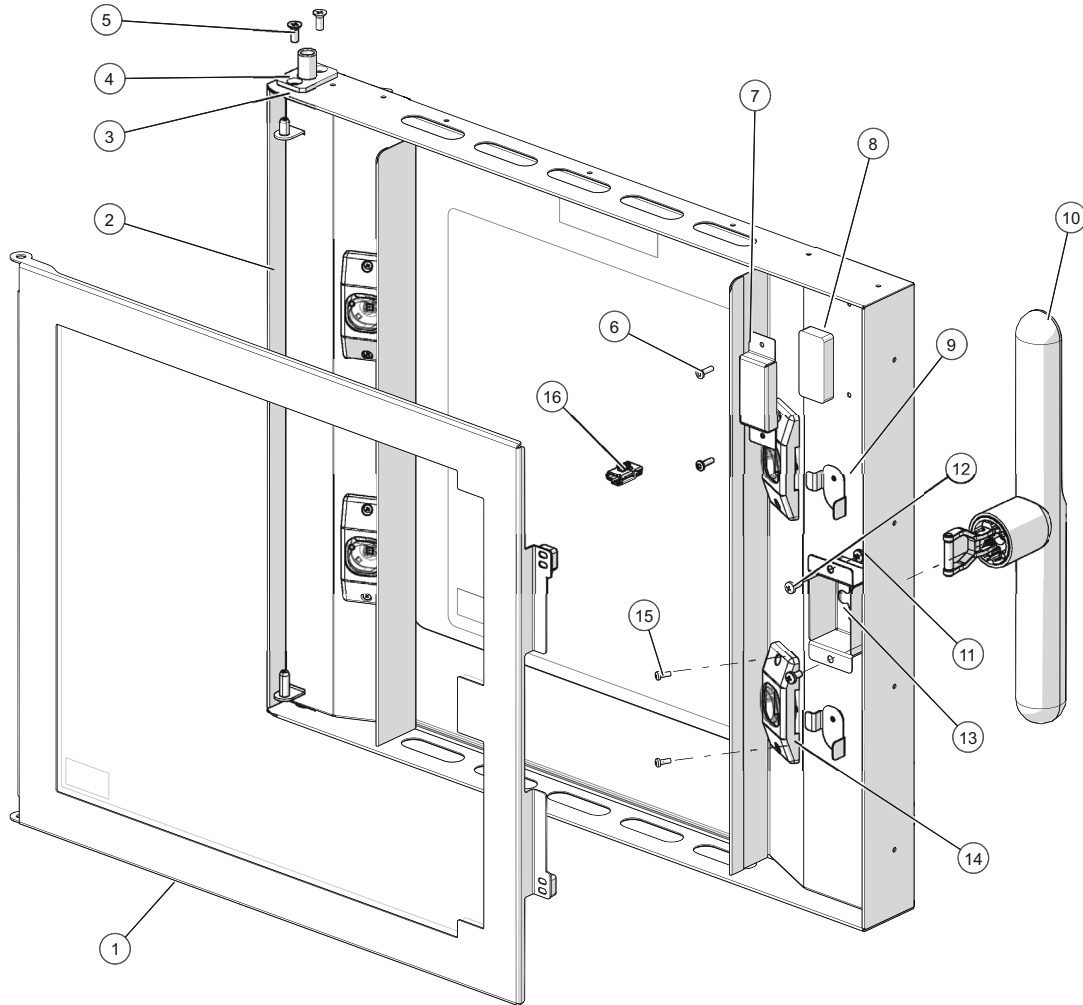

ID	Part No.	Description
1	5028749	DOOR, INNER VH2R
2	5028909	DOOR ASSY, OUTER, VH2R DX
3	HG-39656	HINGE, PLATE, DOOR PIN
4	HG-39655	HINGE, PIN, DOOR, ADJUSTABLE
5	SC-46158	SCREW, M5x0.8X12MM FLAT
6	RI-27108	RIVET, SEALED
7	1007699	COVER, MAGNET, INSIDE, SINGLE
8	MA-25734	MAGNET, DOOR, AR-7E, BLACK
9	1030560	INNER DOOR CLIP LOCK, RH
10	5028179	HANDLE, PENDULUM, LH, W/LIGHT
11	NU-26866	NUT, HEX INSERT M4
12	SC-46575	SCREW, M4 X 8MM, PHH
13	1031270	BRACKET, DOOR HANDLE ACCESS
14	5028680	ASSEMBLY, LED IN-DOOR
15	SC-22268	SCREW, M3x0.5X8MM PAN
16	CR-46285	CONNECTOR, 4 POS, POS LOC
17	CB-46433	CABLE HARNESS, CAVITY LIGHTS (not shown)
18	CB-46902	CABLE HARNESS, HANDLE LIGHT (not shown)

Door Assembly, Left, H2/H2H

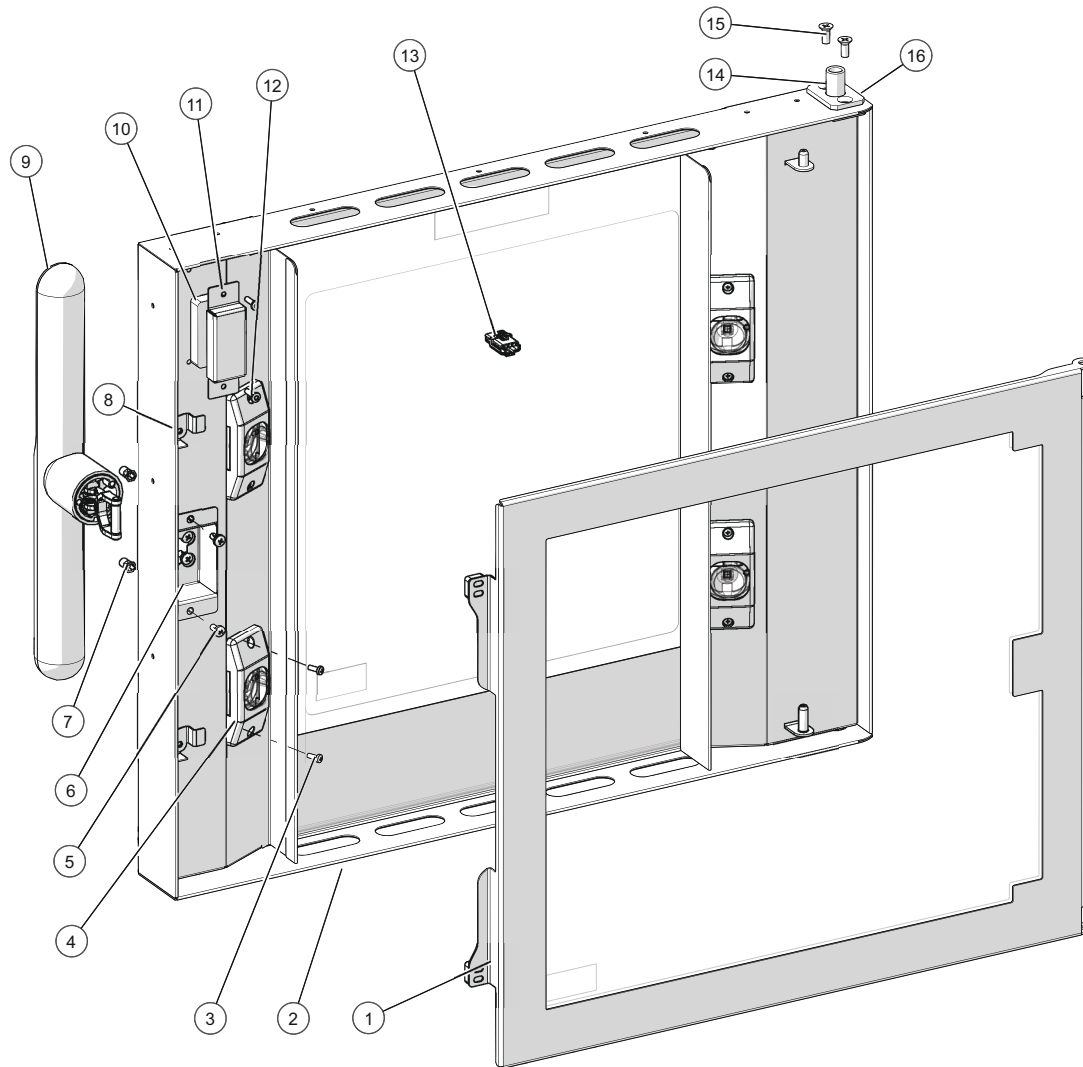

ID	Part No.	Description
1	5028791	DOOR, INNER GLASS, VH2L
2	5028910	DOOR ASSY, OUTER, VH2L DX
3	SC-22268	SCREW, M3x0.5X8MM PAN
4	5028680	ASSEMBLY, LED IN-DOOR
5	SC-46575	SCREW, M4 X 8MM, PHH
6	1032072	BRACKET, DOOR HANDLE ACCESS
7	NU-26866	NUT, HEX INSERT M4
8	1030762	INNER DOOR CLIP LOCK, LH
9	5028179	HANDLE, PENDULUM, LH, W/LIGHT
10	MA-25734	MAGNET, DOOR, AR-7E, BLACK
11	1007699	COVER, MAGNET, INSIDE, SINGLE
12	RI-27108	RIVET, SEALED
13	CR-46285	CONNECTOR, 4 POS, POS LOC
14	HG-39655	HINGE, PIN, DOOR, ADJUSTABLE
15	SC-46158	SCREW, M5x0.8X12MM FLAT
16	HG-39656	HINGE, PLATE, DOOR PIN
17	CB-46433	CABLE HARNESS, CAVITY LIGHTS (not shown)
18	CB-46902	CABLE HARNESS, HANDLE LIGHT (not shown)

Door Assembly, Right, H3/H3H

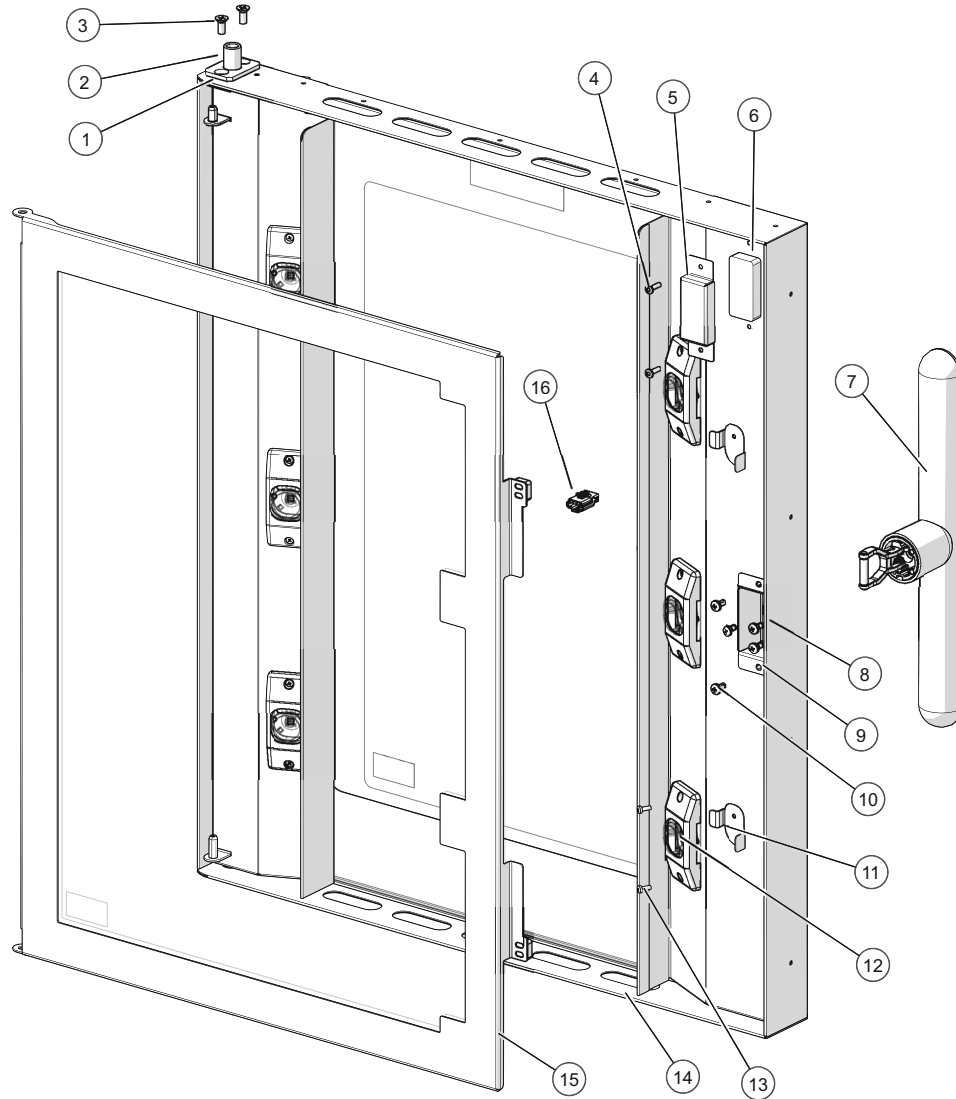

ID	Part No.	Description
1	HG-39656	HINGE, PLATE, DOOR PIN
2	HG-39655	HINGE, PIN, DOOR, ADJUSTABLE
3	SC-46158	SCREW, M5x0.8X12MM FLAT
4	RI-27108	RIVET, SEALED
5	1007699	COVER, MAGNET, INSIDE, SINGLE
6	MA-25734	MAGNET, DOOR, AR-7E, BLACK
7	5028179	HANDLE, PENDULUM, LH, W/LIGHT
8	1031270	BRACKET, DOOR HANDLE ACCESS
9	NU-26866	NUT, HEX INSERT M4
10	SC-46575	SCREW, M4 X 8MM, PHH
11	1030560	INNER DOOR CLIP LOCK, RH
12	5028680	ASSEMBLY, LED IN-DOOR
13	SC-22268	SCREW, M3x0.5X8MM PAN
14	5028907	DOOR ASSY, OUTER, VH3R DX
15	5028737	DOOR, INNER VH3R
16	CR-46285	CONNECTOR, 4 POS, POS LOC
17	CB-46433	CABLE HARNESS, CAVITY LIGHTS (not shown)
18	CB-46902	CABLE HARNESS, HANDLE LIGHT (not shown)

Door Assembly, Left, H3/H3H

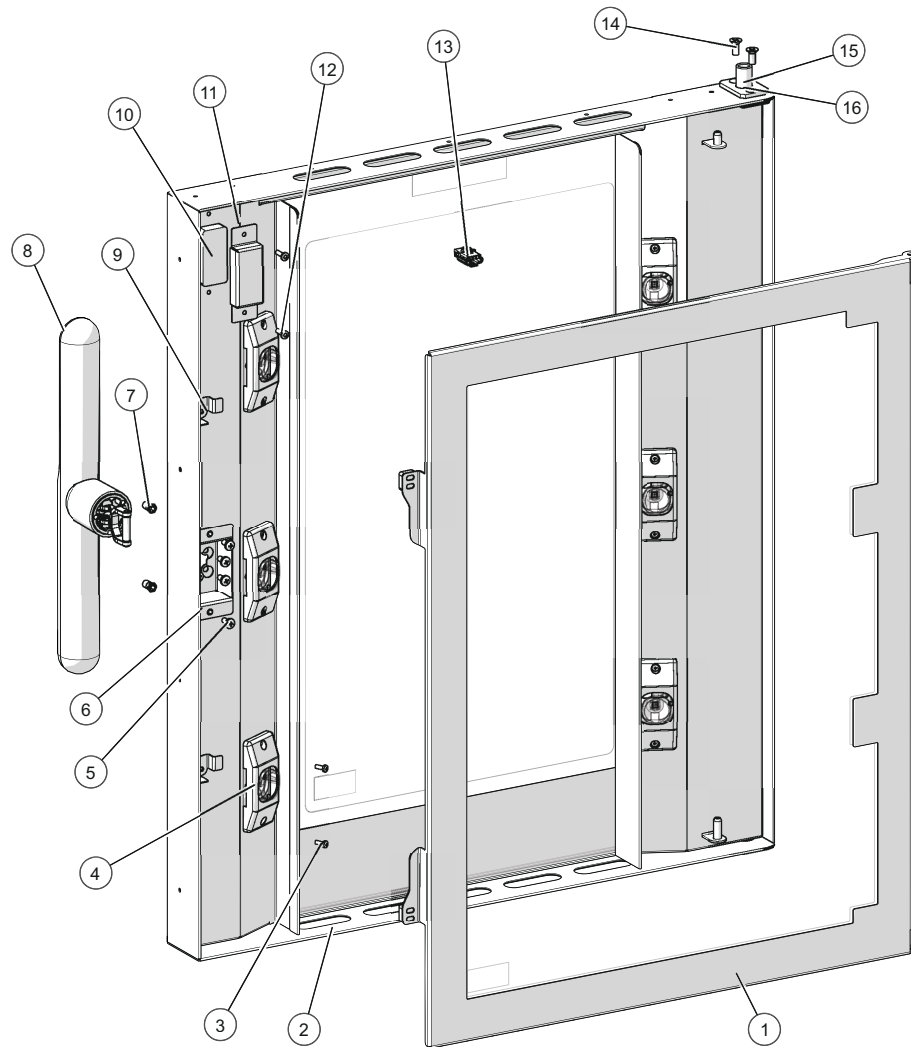

ID	Part No.	Description
1	5028786	DOOR, INNER GLASS, VH3L
2	5028908	DOOR ASSY, OUTER, VH3L DX
3	SC-22268	SCREW, M3x0.5X8MM PAN
4	5028680	ASSEMBLY, LED IN-DOOR
5	SC-46575	SCREW, M4 X 8MM, PHH
6	1032072	BRACKET, DOOR HANDLE ACCESS
7	NU-26866	NUT, HEX INSERT M4
8	5028179	HANDLE, PENDULUM, LH, W/LIGHT
9	1030762	INNER DOOR CLIP LOCK, LH
10	MA-25734	MAGNET, DOOR, AR-7E, BLACK
11	1007699	COVER, MAGNET, INSIDE, SINGLE
12	RI-27108	RIVET, SEALED
13	CR-46285	CONNECTOR, 4 POS, POS LOC
14	SC-46158	SCREW, M5x0.8X12MM FLAT
15	HG-39655	HINGE, PIN, DOOR, ADJUSTABLE
16	HG-39656	HINGE, PLATE, DOOR PIN
17	CB-46433	CABLE HARNESS, CAVITY LIGHTS (not shown)
18	CB-46902	CABLE HARNESS, HANDLE LIGHT (not shown)

Door Assembly, Right, H4/H4H

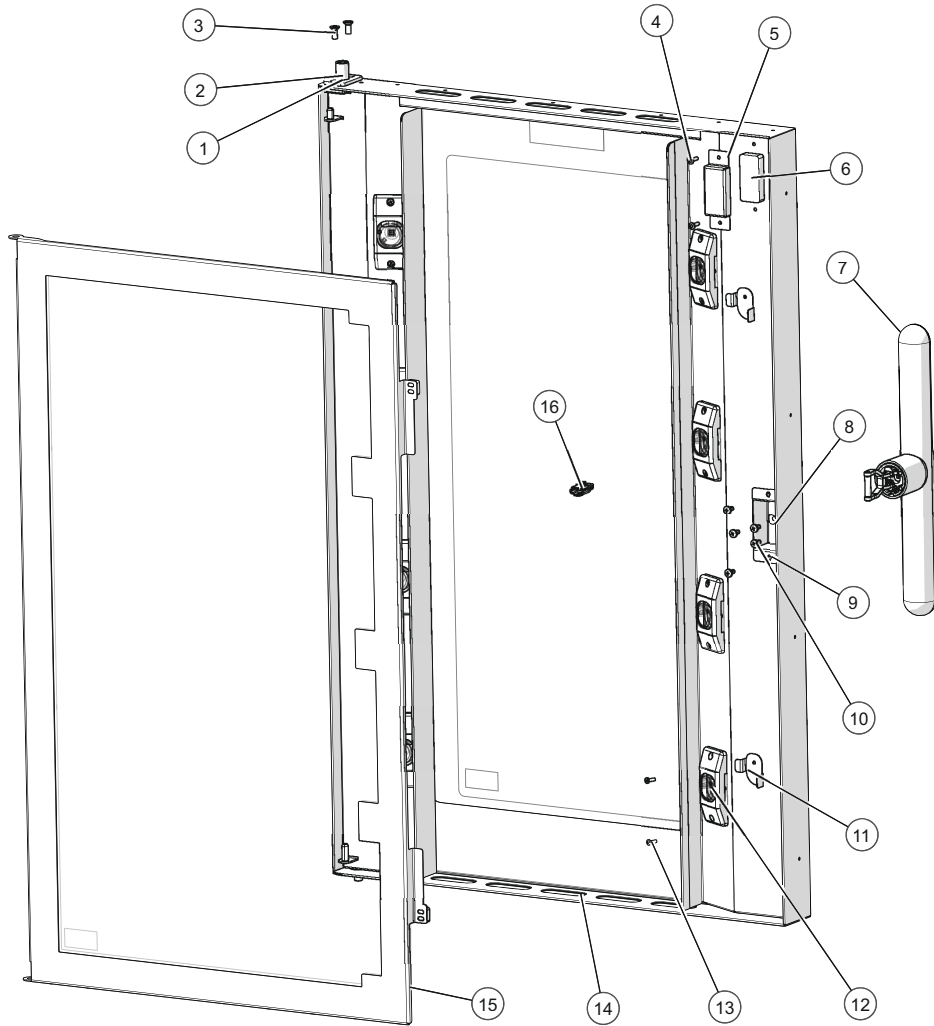

ID	Part No.	Description
1	HG-39656	HINGE, PLATE, DOOR PIN
2	HG-39655	HINGE, PIN, DOOR, ADJUSTABLE
3	SC-46158	SCREW, M5x0.8X12MM FLAT
4	RI-27108	RIVET, SEALED
5	1007699	COVER, MAGNET, INSIDE, SINGLE
6	MA-25734	MAGNET, DOOR, AR-7E, BLACK
7	5028179	HANDLE, PENDULUM, LH, W/LIGHT
8	1031270	BRACKET, DOOR HANDLE ACCESS
9	NU-26866	NUT, HEX INSERT M4
10	SC-46575	SCREW, M4 X 8MM, PHH
11	1030560	INNER DOOR CLIP LOCK, RH
12	5028680	ASSEMBLY, LED IN-DOOR
13	SC-22268	SCREW, M3x0.5X8MM PAN
14	5028905	DOOR ASSY, OUTER, VH4R DX
15	5028681	DOOR, INNER VH4R
16	CR-46285	CONNECTOR, 4 POS, POS LOC
100	CB-46433	CABLE HARNESS, CAVITY LIGHTS (not shown)
101	CB-46902	CABLE HARNESS, HANDLE LIGHT (not shown)

Door Assembly, Left, H4/H4H

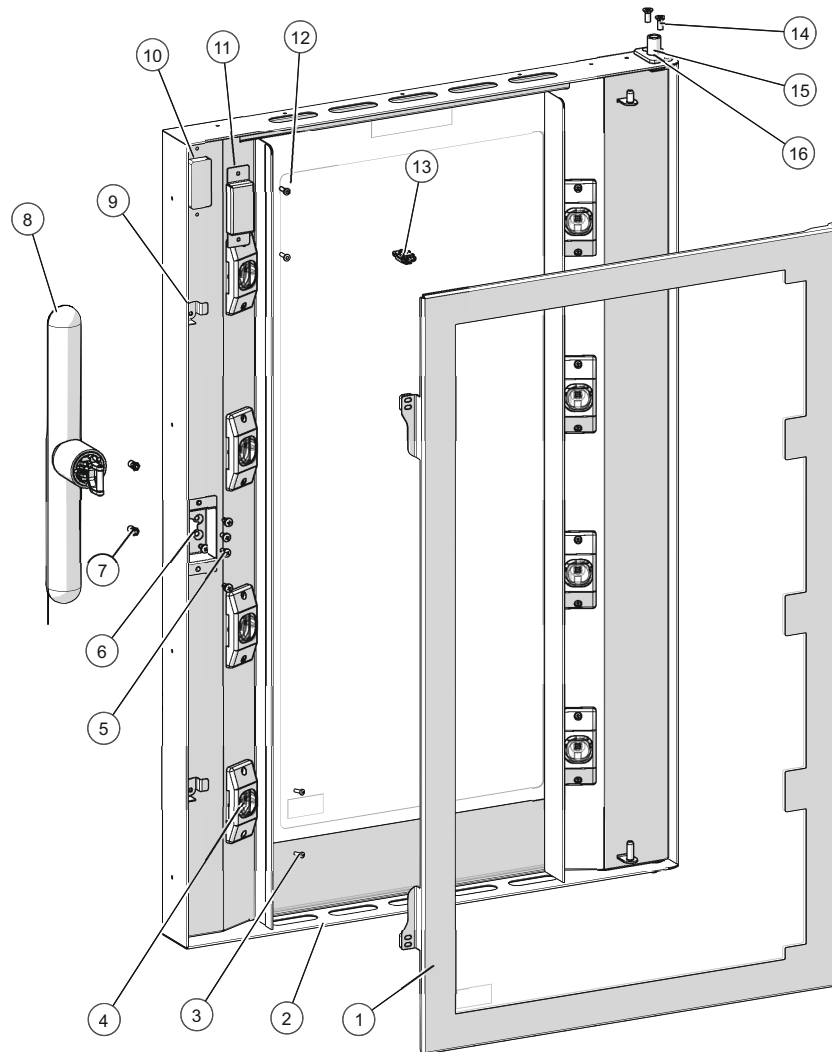

ID	Part No.	Description
1	5028776	DOOR, INNER GLASS, VH4L
2	5028906	DOOR ASSY, OUTER, VH4L DX
3	SC-22268	SCREW, M3x0.5X8MM PAN
4	5028680	ASSEMBLY, LED IN-DOOR
5	SC-46575	SCREW, M4 X 8MM, PHH
6	1032072	BRACKET, DOOR HANDLE ACCESS
7	NU-26866	NUT, HEX INSERT M4
8	5028179	HANDLE, PENDULUM, LH, W/LIGHT
9	1030762	CLIP, INNER DOOR GLASS
10	MA-25734	MAGNET, DOOR, AR-7E, BLACK
11	1007699	COVER, MAGNET, INSIDE, SINGLE
12	RI-27108	RIVET, SEALED
13	CR-46285	CONNECTOR, 4 POS, POS LOC
14	SC-46158	SCREW, M5x0.8X12MM FLAT
15	HG-39655	HINGE, PIN, DOOR, ADJUSTABLE
16	HG-39656	HINGE, PLATE, DOOR PIN
17	CB-46433	CABLE HARNESS, CAVITY LIGHTS (not shown)
18	CB-46902	CABLE HARNESS, HANDLE LIGHT (not shown)

Control Panel, All Models

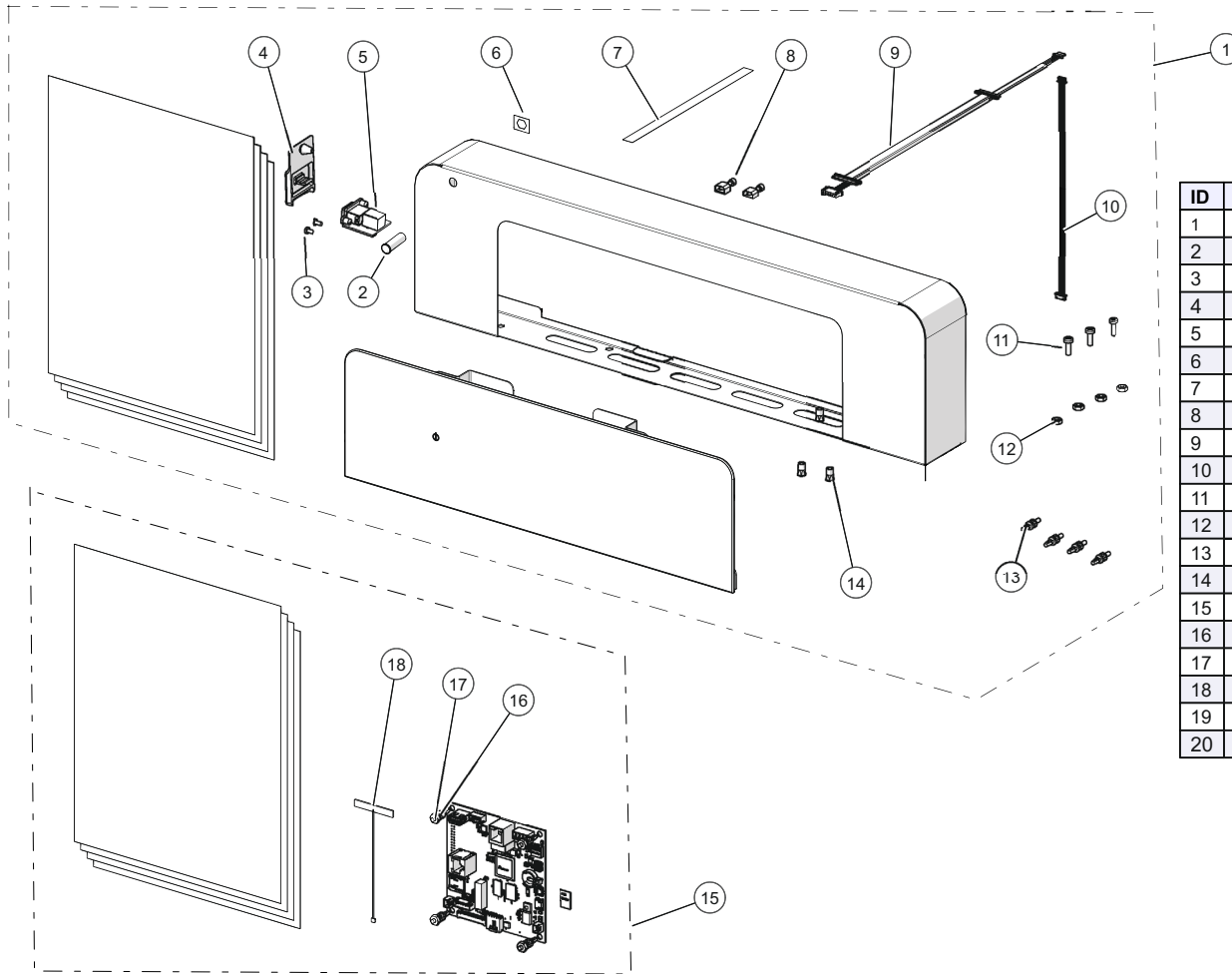

ID	Part No.	Description
1	5028218	HSG W/TOUCH GLASS/USB NO IB
2	LI-37681R	LED, PANEL MOUNT 125/250V
3	SC-22266	SCREW,M3x0.5X6MM PAN
4	CP-39848	CAP,USB
5	BA-39847	BOARD,USB RECEPTACLE
6	CL-37245	CLIP, LIGHT MOUNTING XYZ
7	TA-46558	TAPE,SHIELDING,COND., 7" LONG
8	CR-34639	CONNECTOR, QUICK DISCONNECT
9	CB-46664	CABLE, LVDS & BL, AMPIRE
10	CB-39912	CABLE,PCAP
11	SC-37702	SCREW, M4 X 12MM SEMS
12	NU-39735	NUT,HEX,6-32,NYLON
13	SP-33902	SPACER, 1/4", CIRCUIT BRD
14	NU-26866	NUT, HEX INSERT M4
15	5028178	KIT,SERVICE IB/WiFi ANTENNA
16	SP-33902	SPACER, 1/4", CIRCUIT BRD
17	NU-39735	NUT,HEX,6-32,NYLON
18	CC-46559	ANTENNA, WIFI CONTROL
19	5026359	WIRE/FILTER ASSEMBLY (not shown)
20	TM-36881	TERMINAL PLUG (not shown)

Electrical Chassis, H2/H2H, 208-240V, 60Hz, 1PH

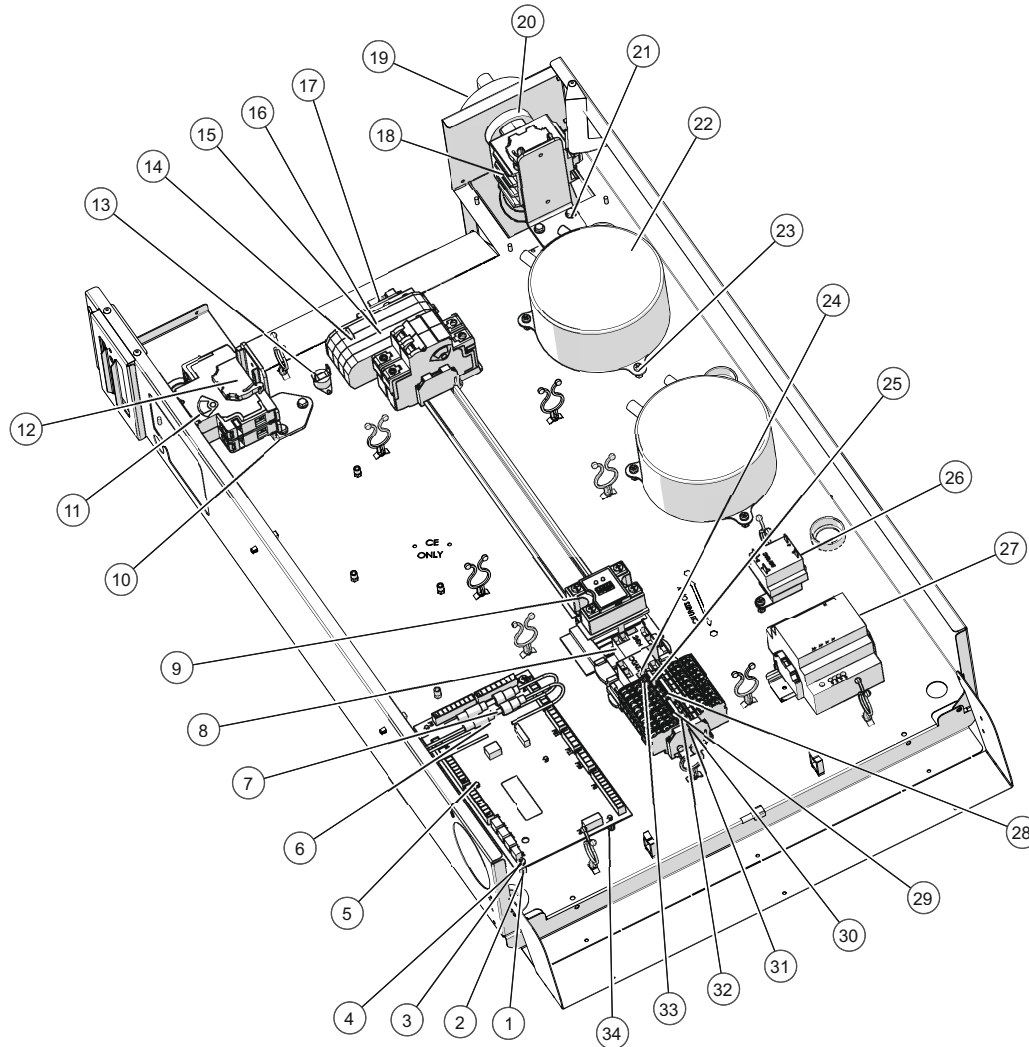

ID	Part No.	Description
1	SP-39373	SPACER, M/F HEX STANDOFF 6MM
2	NU-36319	NUT, M4, KEPS, ZINC PLATED
3	WS-22300	WASHER, M4 SPLIT LOCK
4	SC-35729	SCREW, M4x0.7X8MM PAN
5	CC-39528R	BOARD, CONTROL, FOR VMC
6	FU-36762	IN-LINE FUSE HOLDER, 5X20MM 150 SERIES
7	FU-46554	FUSE, 630mA, 250V, FAST ACTING,
8	RE-37725	RELAY, 240V AC
9	RL-39554	RELAY, SOLID STATE, DUAL, 50A
10	5024641	BRACKET, ELECTRICAL BRACE
11	FU-39058	CIRCUIT BREAKER, 20A
12	TM-39606	TERMINAL, SCREWLESS END
13	TT-37680	THERMOSTAT, AUTO RESET,
14	TM-37727	JUMPER BAR
15	TM-37660	TERMINAL, 6mm, ORANGE, SPRING
16	TM-37726	TERMINAL, 10MM END
17	TM-47500	TERMINAL, GROUND, 35mm
18	SW-37630	POWER SWITCH, DISCONNECT 60A
19	KN-37667	KNOB, POWER, INCLUDED W/SWITCH
20	LK-37670	SHAFT, 2" DISCONNECT, SWITCH
21	SC-39147	SCREW, 8-18 X .480 HEX WASHER
22	BA-46884R	DRIVE, 208-240V TELCO, FLY LEAD
23	SC-37702	SCREW, M4 X 12MM SEMS
24	RE-37704	RELAY, 12VDC
25	TM-39585	JUMPER, 2 POLE
26	TN-37722	TRANSFORMER, 12V OUT, 240V IN,
27	BA-46801	POWER SUPPLY, 12VDC, 100W
28	TM-39583	JUMPER, 4 POLE
29	TM-39584	JUMPER, 3 POLE
30	TM-39576	TERMINAL, END SECTION, SPRING
31	TM-39579	TERMINAL, GROUND, 6mm, SPRING
32	TM-39574	TERMINAL, 6mm, ORANGE, SPRING
33	TM-37674	T BLOCK, RELAY MOUNT
34	SP-39372	SPACER, LOCK-IN SUPPRT

Electrical Chassis, H2/H2H, 220-240V, 50/60Hz, 1PH CE

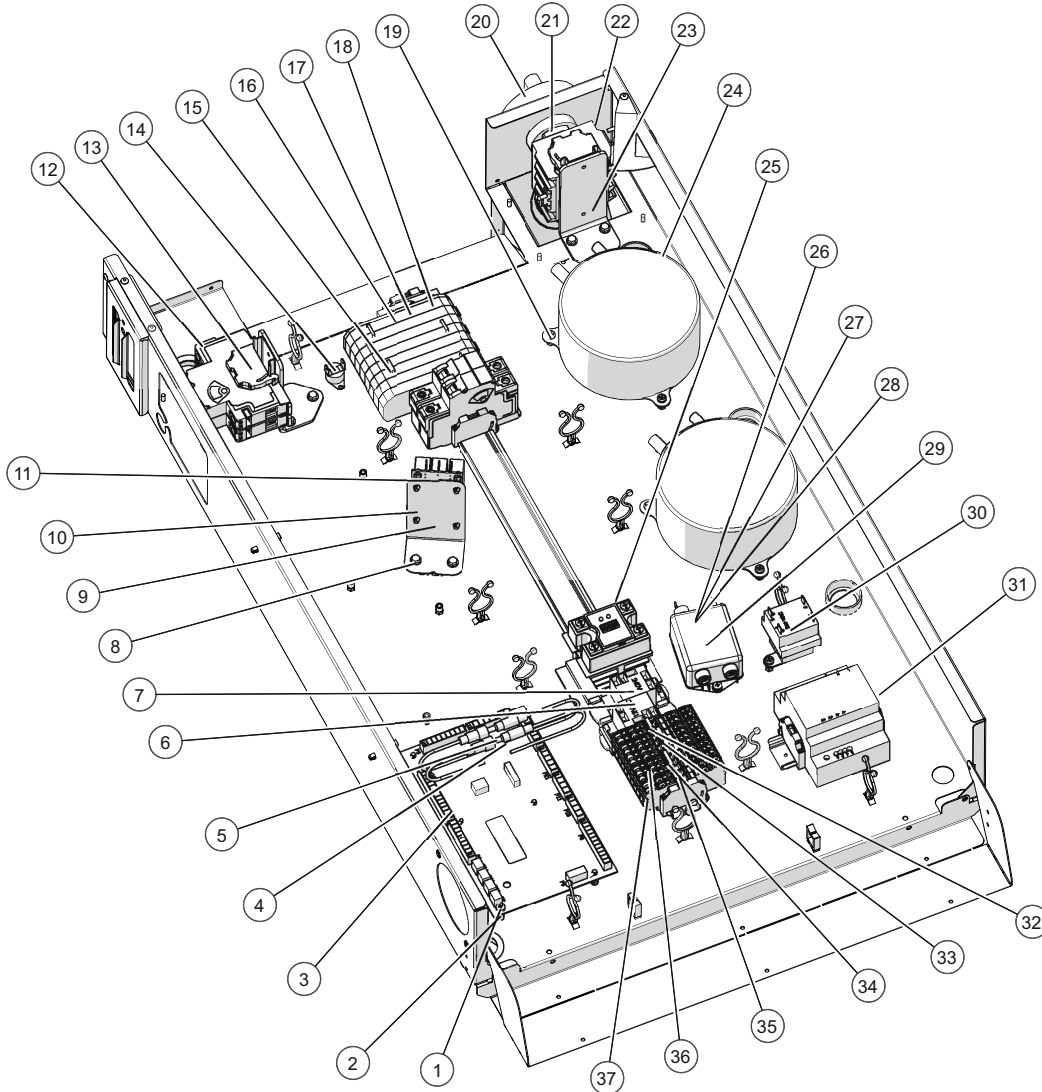

ID	Part No.	Description
1	SC-35729	SCREW,M4x0.7X8MM PAN
2	SP-39373	SPACER, M/F HEX STANDOFF 6MM
3	CC-39528R	BOARD,CONTROL, FOR VMC
4	FU-36762	IN-LINE FUSE HOLDER, 5X20MM 150 SERIES
5	FU-46554	FUSE, 630mA, 250V,FAST ACTING,
6	RE-37704	RELAY, 12VDC
7	RE-37725	RELAY, 240V AC
8	SC-39147	SCREW, 8-18 X .480 HEX WASHER
9	1024693	BRKT, WYE FILTER HOLDER
10	SP-39372	SPACER, LOCK-IN SUPPRT
11	FI-39227	FILTER, WYE F863 SERIES
12	FU-39058	CIRCUIT BREAKER, 20A
13	TM-39606	TERMINAL, SCREWLESS END
14	TT-37680	THERMOSTAT,AUTO RESET,
15	TM-37727	JUMPER BAR
16	TM-37726	TERMINAL, 10MM END
17	TM-47500	TERMINAL, GROUND, 35mm
18	TM-37660	TERMINAL, 6mm, ORANGE, SPRING
19	SC-37702	SCREW, M4 X 12MM SEMS
20	KN-37667	KNOB,POWER,INCLUDED W/SWITCH
21	LK-37670	SHAFT,2" DISCONNECT,SWITCH
22	SW-39228	POWER SWITCH,DISCONNECT 60A
23	5024641	BRACKET, ELECTRICAL BRACE
24	BA-46884	DRIVE, 208-240V TELCO,FLY LEAD
25	RL-39554	RELAY,SOLID STATE,DUAL,50A
26	WS-22300	WASHER, M4 SPLIT LOCK
27	WS-22294	WASHER, FLAT M4 18-8 S/S
28	SC-22273	SCREW,M4x0.7X10MM PAN
29	FI-39226	FILTER, RFI POWER LINE
30	TN-37722	TRANSFORMER,12V OUT,240V IN,
31	BA-46801	POWER SUPPLY, 12VDC, 100W
32	TM-39585	JUMPER, 2 POLE
33	TM-39583	JUMPER, 4 POLE
34	TM-39584	JUMPER, 3 POLE
35	TM-39576	TERMINAL, END SECTION, SPRING
36	TM-39574	TERMINAL, 6mm, ORANGE, SPRING
37	TM-39579	TERMINAL,GROUND, 6mm, SPRING

Electrical Chassis, H2/H2H, 380-415V, 50/60Hz, 3PH CE

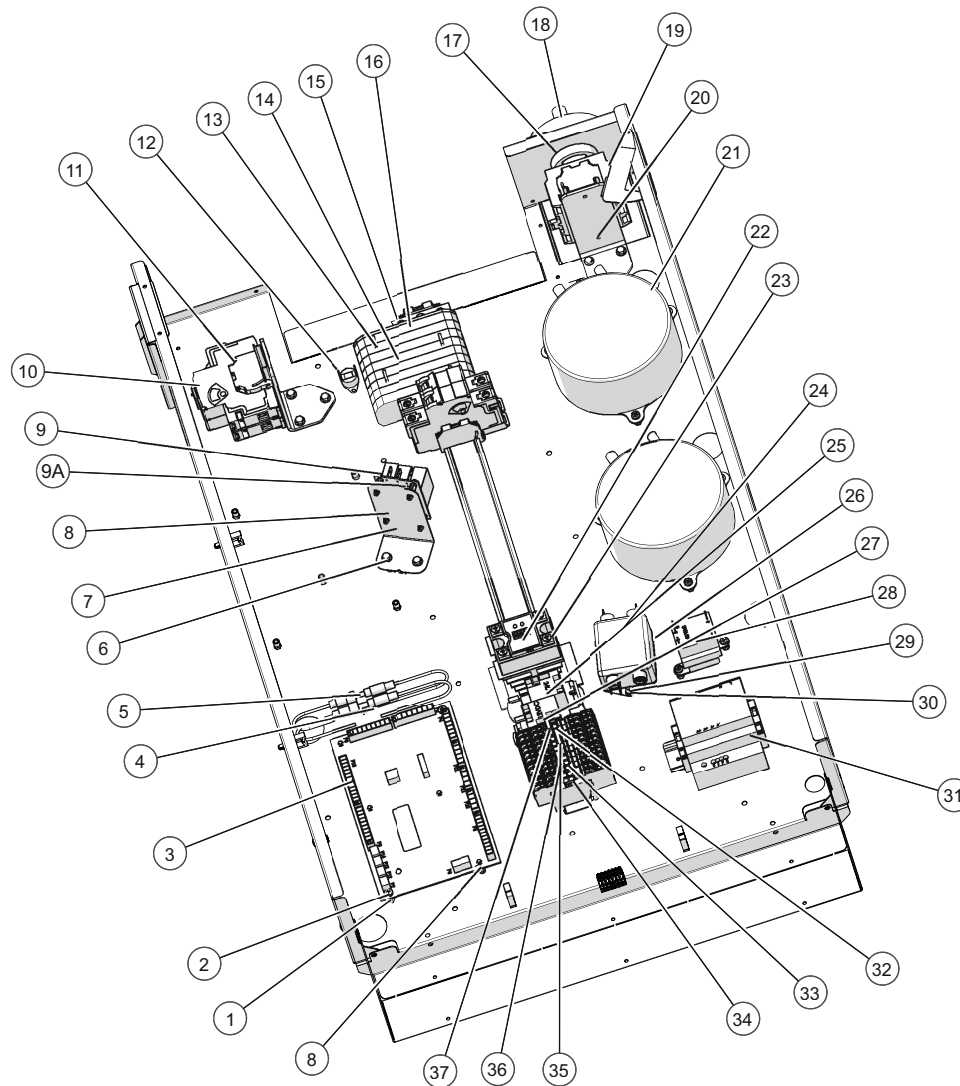

ID	Part No.	Description
1	SP-39373	SPACER, M/F HEX STANDOFF 6MM
2	SC-35729	SCREW,M4x0.7X8MM PAN
3	CC-39528R	BOARD,CONTROL, FOR VMC
4	FU-36762	IN-LINE FUSE HOLDER, 5X20MM 150 SERIES
5	FU-46554	FUSE, 630mA, 250V,FAST ACTING,
6	SC-39147	SCREW, 8-18 X .480 HEX WASHER
7	1024693	BRKT, WYE FILTER HOLDER
8	SP-39372	SPACER, LOCK-IN SUPPRT
9	BA-39285	WYE/CAPACITOR
9A	FI-39227	FILTER, WYE F863 SERIES
10	FU-39058	CIRCUIT BREAKER, 20A
11	TM-39606	TERMINAL, SCREWLESS END
12	TT-37680	THERMOSTAT,AUTO RESET,
13	TM-37727	JUMPER BAR
14	TM-37660	T-BLOCK,DIN,3 POS
15	TM-37726	TERMINAL, 10MM END
16	TM-47500	TERMINAL, GROUND, 35mm
17	LK-37670	SHAFT,2" DISCONNECT,SWITCH
18	KN-37667	KNOB,POWER,INCLUDED W/SWITCH
19	SW-39228	POWER SWITCH,DISCONNECT 60A
20	5024641	BRACKET, ELECTRICAL BRACE
21	BA-46884R	DRIVE, 208-240V TELCO,FLY LEAD
22	RL-39554	RELAY,SOLID STATE,DUAL,50A
23	SC-37702	SCREW, M4 X 12MM SEMS
24	WS-22294	WASHER, FLAT M4 18-8 S/S
25	RE-37725	RELAY, 240V AC
26	FI-39226	FILTER, RFI POWER LINE
27	RE-37704	RELAY, 12VDC
28	TN-37722	TRANSFORMER,12V OUT,240V IN,
29	WS-22300	WASHER, M4 SPLIT LOCK
30	SC-22273	SCREW,M4x0.7X10MM PAN
31	BA-46801	POWER SUPPLY, 12VDC, 100W
32	TM-39576	TERMINAL, END SECTION, SPRING
33	TM-39574	TERMINAL, 6mm, ORANGE, SPRING
34	TM-39579	TERMINAL,GROUND, 6mm, SPRING
35	TM-39583	JUMPER, 4 POLE
36	TM-39584	JUMPER, 3 POLE
37	TM-39585	JUMPER, 2 POLE

Electrical Chassis, H3/H3H, 208-240V, 60Hz, 1PH

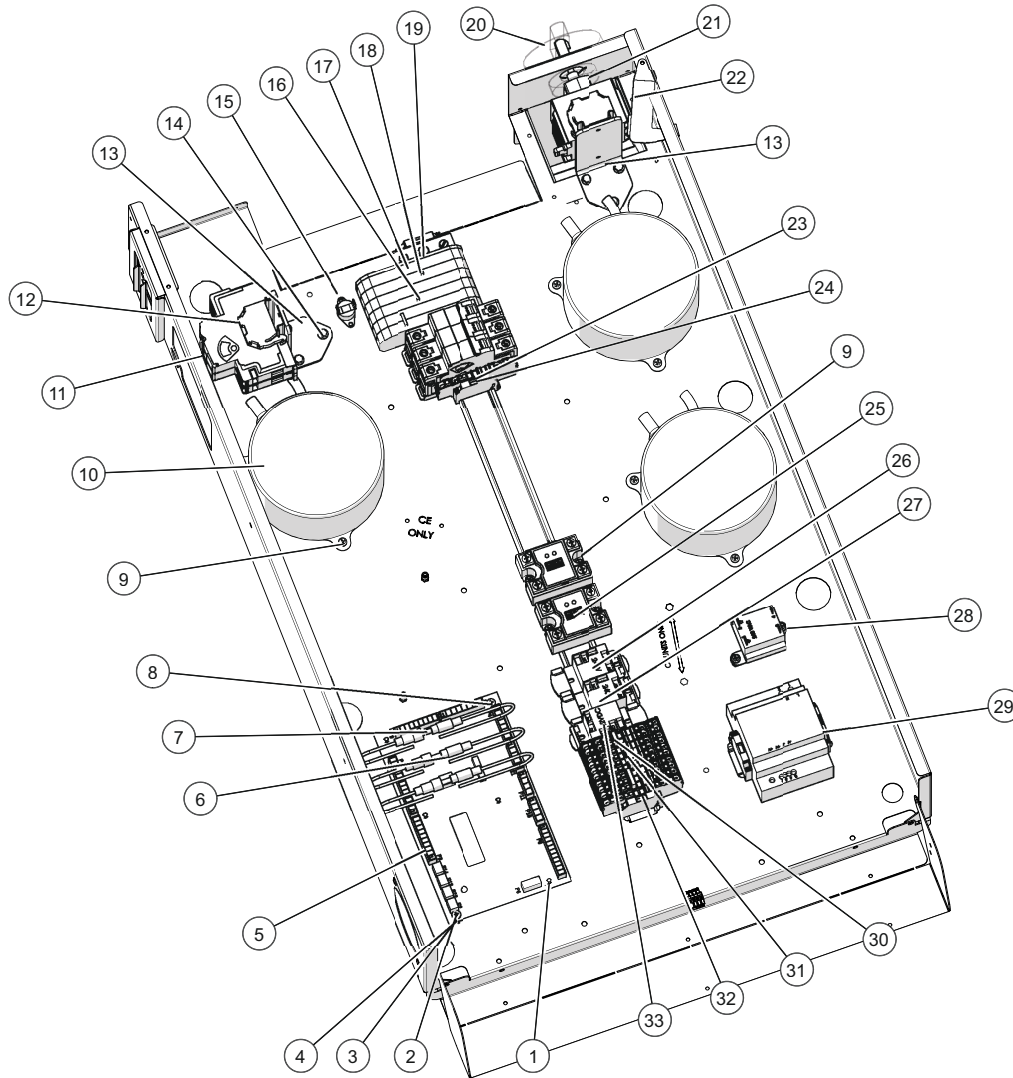

ID	Part No.	Description
1	SP-39372	SPACER, LOCK-IN SUPPRT
2	WS-22300	WASHER, M4 SPLIT LOCK
3	SP-39373	SPACER, M/F HEX STANDOFF 6MM
4	NU-36319	NUT, M4, KEPS, ZINC PLATED
5	CC-39528R	BOARD,CONTROL, FOR VMC
6	FU-36762	IN-LINE FUSE HOLDER, 5X20MM 150 SERIES
7	FU-46554	FUSE, 630mA, 250V,FAST ACTING,
8	SC-35729	SCREW,M4x0.7X8MM PAN
9	SC-37702	SCREW, M4 X 12MM SEMS
10	BA-46884R	DRIVE, 208-240V TELCO,FLY LEAD
11	FU-39058	CIRCUIT BREAKER, 20A
12	TM-39606	TERMINAL, SCREWLESS END
13	5024641	BRACKET, ELECTRICAL BRACE
14	SC-39147	SCREW, 8-18 X .480 HEX WASHER
15	TT-37680	THERMOSTAT,AUTO RESET,
16	TM-37660	TERMINAL, 10mm, ORANGE, SPRING
17	TM-37726	TERMINAL,10MM END
18	TM-37727	JUMPER BAR
19	TM-47500	TERMINAL, GROUND, 35mm
20	KN-37667	KNOB,POWER,INCLUDED W/SWITCH
21	LK-37670	SHAFT,2" DISCONNECT,SWITCH
22	SW-37630	POWER SWITCH,DISCONNECT 60A
23	TM-39574	TERMINAL, 6mm, ORANGE, SPRING
24	TM-39576	TERMINAL, END SECTION, SPRING
25	RL-39554	RELAY,SOLID STATE,DUAL,50A
26	RE-37725	RELAY, 240V AC
27	TM-37674	T BLOCK, RELAY MOUNT
28	TN-37722	TRANSFORMER,12V OUT,240V IN,
29	BA-46801	POWER SUPPLY, 12VDC, 100W
30	TM-39585	JUMPER, 2 POLE
31	TM-39583	JUMPER, 4 POLE
32	TM-39579	TERMINAL,GROUND, 6mm, SPRING
33	RE-37704	RELAY, 12VDC

Electrical Chassis, H3/H3H, 208-240V, 60Hz, 3PH

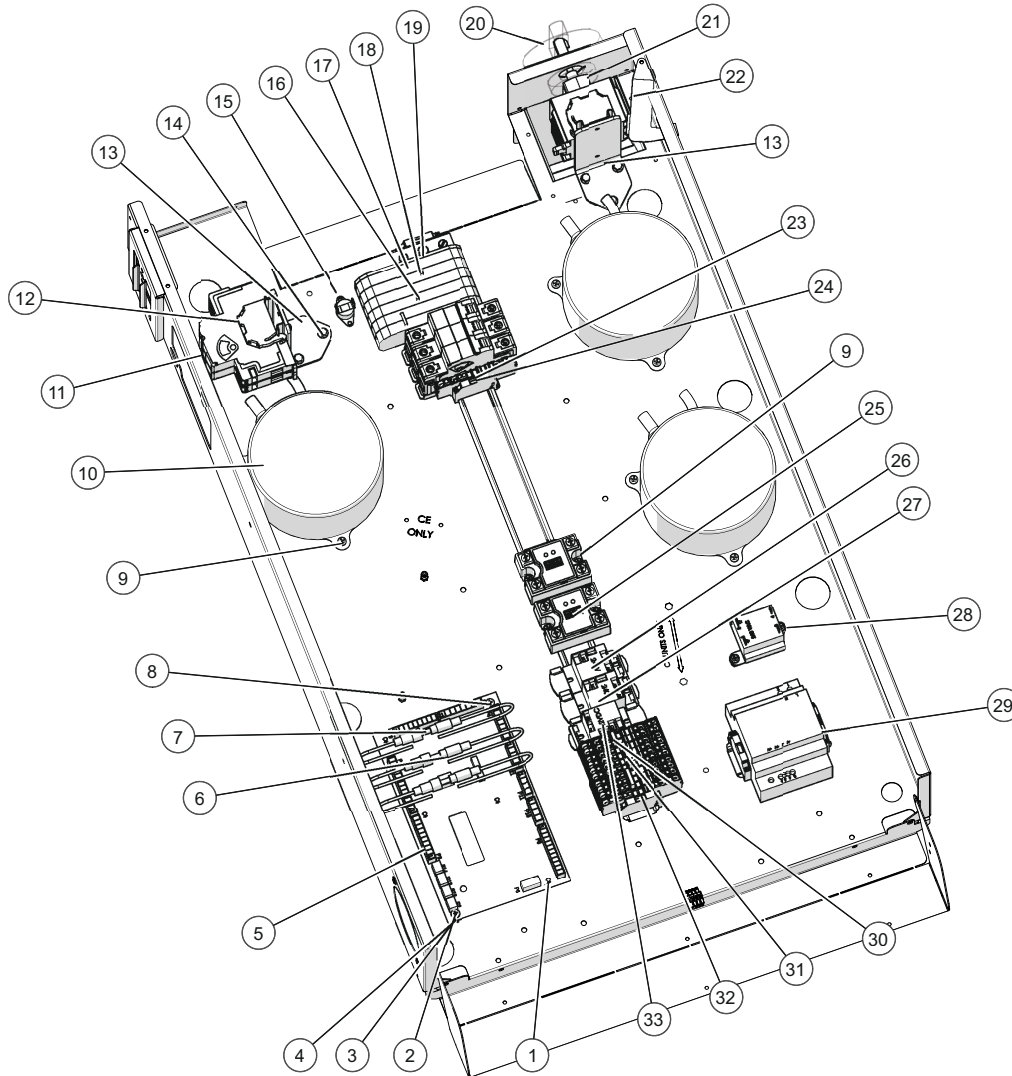

ID	Part No.	Description
1	SP-39372	SPACER, LOCK-IN SUPPRT
2	WS-22300	WASHER, M4 SPLIT LOCK
3	SP-39373	SPACER, M/F HEX STANDOFF 6MM
4	NU-36319	NUT, M4, KEPS, ZINC PLATED
5	CC-39528R	BOARD,CONTROL, FOR VMC
6	FU-36762	IN-LINE FUSE HOLDER, 5X20MM 150 SERIES
7	FU-46554	FUSE, 630mA, 250V,FAST ACTING,
8	SC-35729	SCREW,M4x0.7X8MM PAN
9	SC-37702	SCREW, M4 X 12MM SEMS
10	BA-46884R	DRIVE, 208-240V TELCO,FLY LEAD
11	FU-39058	CIRCUIT BREAKER, 20A
12	TM-39606	TERMINAL, SCREWLESS END
13	5024641	BRACKET, ELECTRICAL BRACE
14	SC-39147	SCREW, 8-18 X .480 HEX WASHER
15	TT-37680	THERMOSTAT,AUTO RESET,
16	TM-37660	TERMINAL, 10mm, ORANGE, SPRING
17	TM-37726	TERMINAL,10MM END
18	TM-37727	JUMPER BAR
19	TM-47500	TERMINAL, GROUND, 35mm
20	KN-37667	KNOB,POWER,INCLUDED W/SWITCH
21	LK-37670	SHAFT,2" DISCONNECT,SWITCH
22	SW-37630	POWER SWITCH,DISCONNECT 60A
23	TM-39574	TERMINAL, 6mm, ORANGE, SPRING
24	TM-39576	TERMINAL, END SECTION, SPRING
25	RL-39554	RELAY,SOLID STATE,DUAL,50A
26	RE-37725	RELAY, 240V AC
27	TM-37674	T BLOCK, RELAY MOUNT
28	TN-37722	TRANSFORMER,12V OUT,240V IN,
29	BA-46801	POWER SUPPLY, 12VDC, 100W
30	TM-39585	JUMPER, 2 POLE
31	TM-39583	JUMPER, 4 POLE
32	TM-39579	TERMINAL,GROUND, 6mm, SPRING
33	RE-37704	RELAY, 12VDC

Electrical Chassis, H3/H3H, 380-415V, 50/60Hz, 3PH CE

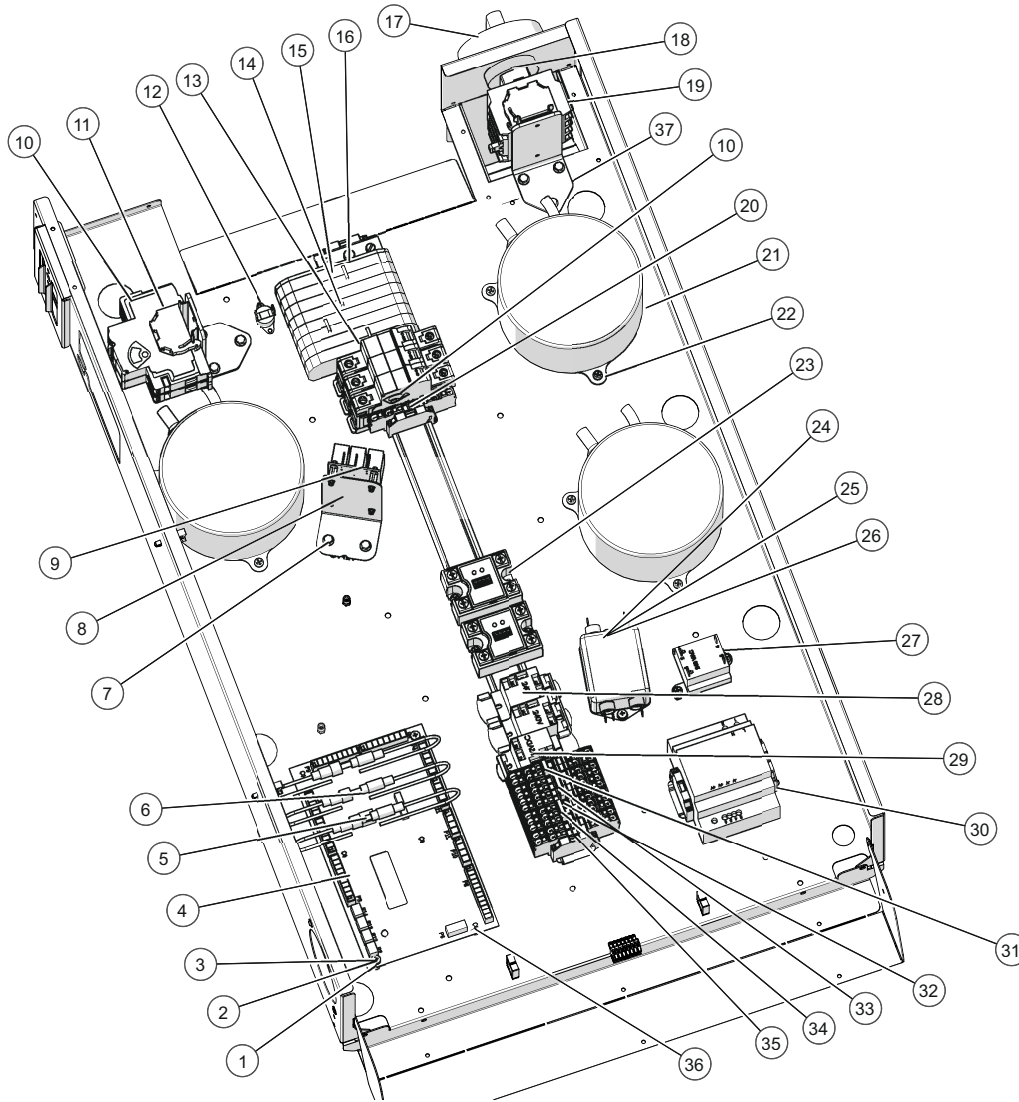

ID	Part No.	Description
1	SP-39373	SPACER, M/F HEX STANDOFF 6MM
2	SC-35729	SCREW,M4x0.7X8MM PAN
3	WS-22300	WASHER, M4 SPLIT LOCK
4	CC-39528R	BOARD,CONTROL, FOR VMC
5	FU-46554	FUSE, 630mA, 250V,FAST ACTING,
6	FU-36762	IN-LINE FUSE HOLDER, 5X20MM 150 SERIES
7	SC-39147	SCREW, 8-18 X .480 HEX WASHER
8	1024693	BRKT, WYE FILTER HOLDER
9	FI-39227	FILTER, WYE F863 SERIES
10	FU-39058	CIRCUIT BREAKER, 20A
11	TM-39606	TERMINAL, SCREWLESS END
12	TT-37680	THERMOSTAT,AUTO RESET,
13	TM-37660	TERMINAL, 10mm, ORANGE, SPRING
14	TM-37727	JUMPER BAR
15	TM-37726	TERMINAL,10MM END
16	TM-47500	TERMINAL, GROUND, 35mm
17	KN-37667	KNOB,POWER,INCLUDED W/SWITCH
18	LK-37670	SHAFT,2" DISCONNECT,SWITCH
19	SW-39228	POWER SWITCH,DISCONNECT 60A
20	TM-39576	TERMINAL, END SECTION, SPRING
21	BA-46884R	DRIVE, 208-240V TELCO,FLY LEAD
22	SC-37702	SCREW, M4 X 12MM SEMS
23	RL-39554	RELAY,SOLID STATE,DUAL,50A
24	FI-39226	FILTER, RFI POWER LINE
25	WS-22294	WASHER, FLAT M4 18-8 S/S
26	SC-22273	SCREW,M4x0.7X10MM PAN
27	TN-37722	TRANSFORMER,12V OUT,240V IN,
28	RE-37725	RELAY, 240V AC
29	RE-37704	RELAY, 12VDC
30	BA-46801	POWER SUPPLY, 12VDC, 100W
31	TM-39585	JUMPER, 2 POLE
32	TM-39574	TERMINAL, 6mm, ORANGE, SPRING
33	TM-39583	JUMPER, 4 POLE
34	TM-39584	JUMPER, 3 POLE
35	TM-39579	TERMINAL,GROUND, 6mm, SPRING
36	SP-39372	SPACER, LOCK-IN SUPPRT
37	5024641	BRACKET, ELECTRICAL BRACE

Electrical Chassis, H4/H4H, 220-240V, 60Hz, 3PH

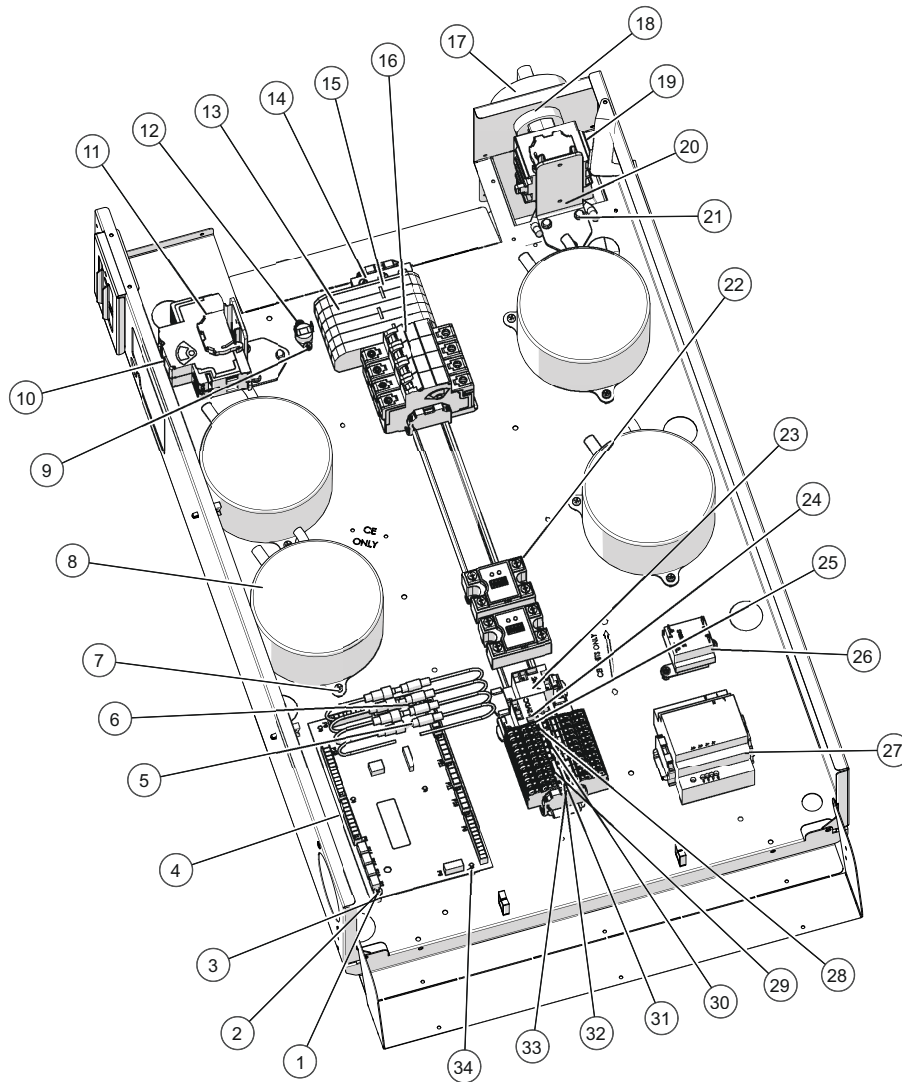

ID	Part No.	Description
1	WS-22300	WASHER, M4 SPLIT LOCK
2	SC-35729	SCREW, M4x0.7X8MM PAN
3	SP-39373	SPACER, M/F HEX STANDOFF 6MM
4	CC-39528R	BOARD, CONTROL, FOR VMC
5	FU-46554	FUSE, 630mA, 250V, FAST ACTING,
6	FU-36762	IN-LINE FUSE HOLDER, 5X20MM 150 SERIES
7	SC-37702	SCREW, M4 X 12MM SEMS
8	BA-46884	DRIVE, 208-240V TELCO, FLY LEAD
9	SC-38693	SCREW, #8-18 X 1/2", PHIL, PAN
10	FU-39058	CIRCUIT BREAKER, 20A
11	TM-39606	TERMINAL, SCREWLESS END
12	TT-37680	THERMOSTAT, AUTO RESET,
13	TM-37660	TERMINAL, 6mm, ORANGE, SPRING
14	TM-37726	TERMINAL, 10MM END
15	TM-47500	TERMINAL, GROUND, 35mm
16		JUMPER BAR
17	KN-37667	KNOB, POWER, INCLUDED W/SWITCH
18	LK-37670	SHAFT, 2" DISCONNECT, SWITCH
19	SW-37630	POWER SWITCH, DISCONNECT 60A
20	5024641	BRACKET, ELECTRICAL BRACE
21	SC-39147	SCREW, 8-18 X .480 HEX WASHER
22	RL-39554	RELAY, SOLID STATE, DUAL, 50A
23	RE-37725	RELAY, 240V AC
24	RE-37704	RELAY, 12VDC
25	TM-37674	T BLOCK, RELAY MOUNT
26	TN-37722	TRANSFORMER, 12V OUT, 240V IN,
27	BA-46801	POWER SUPPLY, 12VDC, 100W
28	TM-39585	JUMPER, 2 POLE
29	TM-39584	JUMPER, 3 POLE
30	TM-39582	JUMPER, 5 POLE
31	TM-39576	TERMINAL, END SECTION, SPRING
32	TM-39574	TERMINAL, 6mm, ORANGE, SPRING
33	TM-39579	TERMINAL, GROUND, 6mm, SPRING
34	SP-39372	SPACER, LOCK-IN SUPPRT

Electrical Chassis, H4/H4H, 380-415V, 50/60Hz, 3PH CE

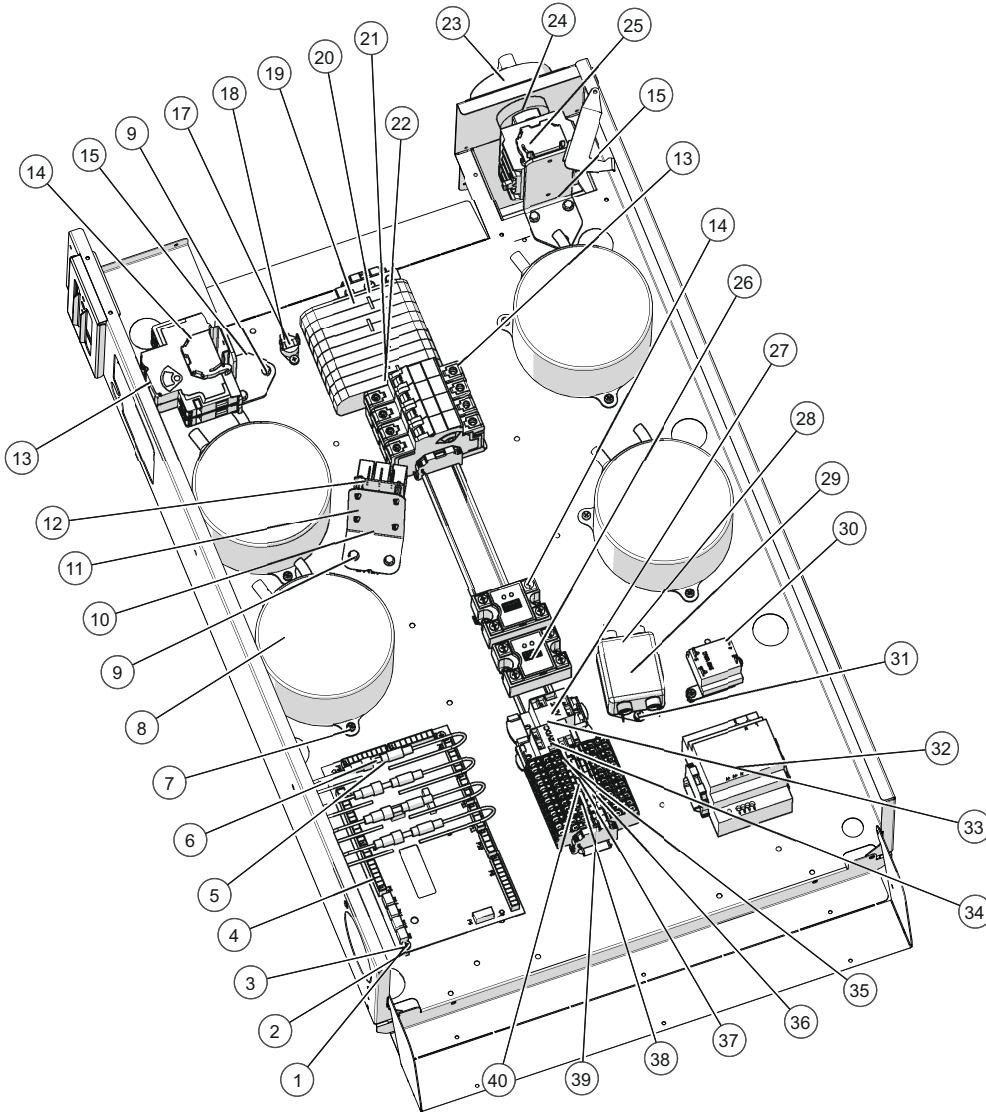

ID	Part No.	Description
1	WS-22300	WASHER, M4 SPLIT LOCK
2	SP-39373	SPACER, M/F HEX STANDOFF 6MM
3	SC-35729	SCREW, M4x0.7X8MM PAN
4	CC-39528R	BOARD, CONTROL, FOR VMC
5	FU-36762	IN-LINE FUSE HOLDER, 5X20MM 150 SERIES
6	FU-46554	FUSE, 630mA, 250V, FAST ACTING,
7	SC-37702	SCREW, M4 X 12MM SEMS
8	BA-46884R	DRIVE, 208-240V TELCO, FLY LEAD
9	SC-39147	SCREW, 8-18 X .480 HEX WASHER
10	1024693	BRKT, WYE FILTER HOLDER
11	SP-39372	SPACER, LOCK-IN SUPPRT
12	FI-39227	FILTER, WYE F863 SERIES
13	FU-39058	CIRCUIT BREAKER, 20A
14	TM-39606	TERMINAL, SCREWLESS END
15	5024641	BRACKET, ELECTRICAL BRACE
17	TT-37680	THERMOSTAT, AUTO RESET,
18	SC-38693	SCREW, #8-18 X 1/2", PHIL, PAN
19	TM-37726	TERMINAL, 10MM END
20	TM-47500	TERMINAL, GROUND, 35mm
21	TM-37727	JUMPER BAR
22	TM-37660	TERMINAL, 6mm, ORANGE, SPRING
23	KN-37667	KNOB, POWER, INCLUDED W/SWITCH
24	LK-37670	SHAFT, 2" DISCONNECT, SWITCH
25	SW-39228	POWER SWITCH, DISCONNECT 60A
26	RL-39554	RELAY, SOLID STATE, DUAL, 50A
27	RE-37725	RELAY, 240V AC
28	WS-22294	WASHER, FLAT M4 18-8 S/S
29	FI-39226	FILTER, RFI POWER LINE
30	TN-37722	TRANSFORMER, 12V OUT, 240V IN,
31	SC-22273	SCREW, M4x0.7X10MM PAN
32	BA-46801	POWER SUPPLY, 12VDC, 100W
33	TM-37674	T BLOCK, RELAY MOUNT
34	RE-37704	RELAY, 12VDC
35	TM-39576	TERMINAL, END SECTION, SPRING
36	TM-39585	JUMPER, 2 POLE
37	TM-39582	JUMPER, 5 POLE
38	TM-39584	JUMPER, 3 POLE
39	TM-39579	TERMINAL, GROUND, 6mm, SPRING
40	TM-39574	TERMINAL, 6mm, ORANGE, SPRING

Core Components, H2 (RH)

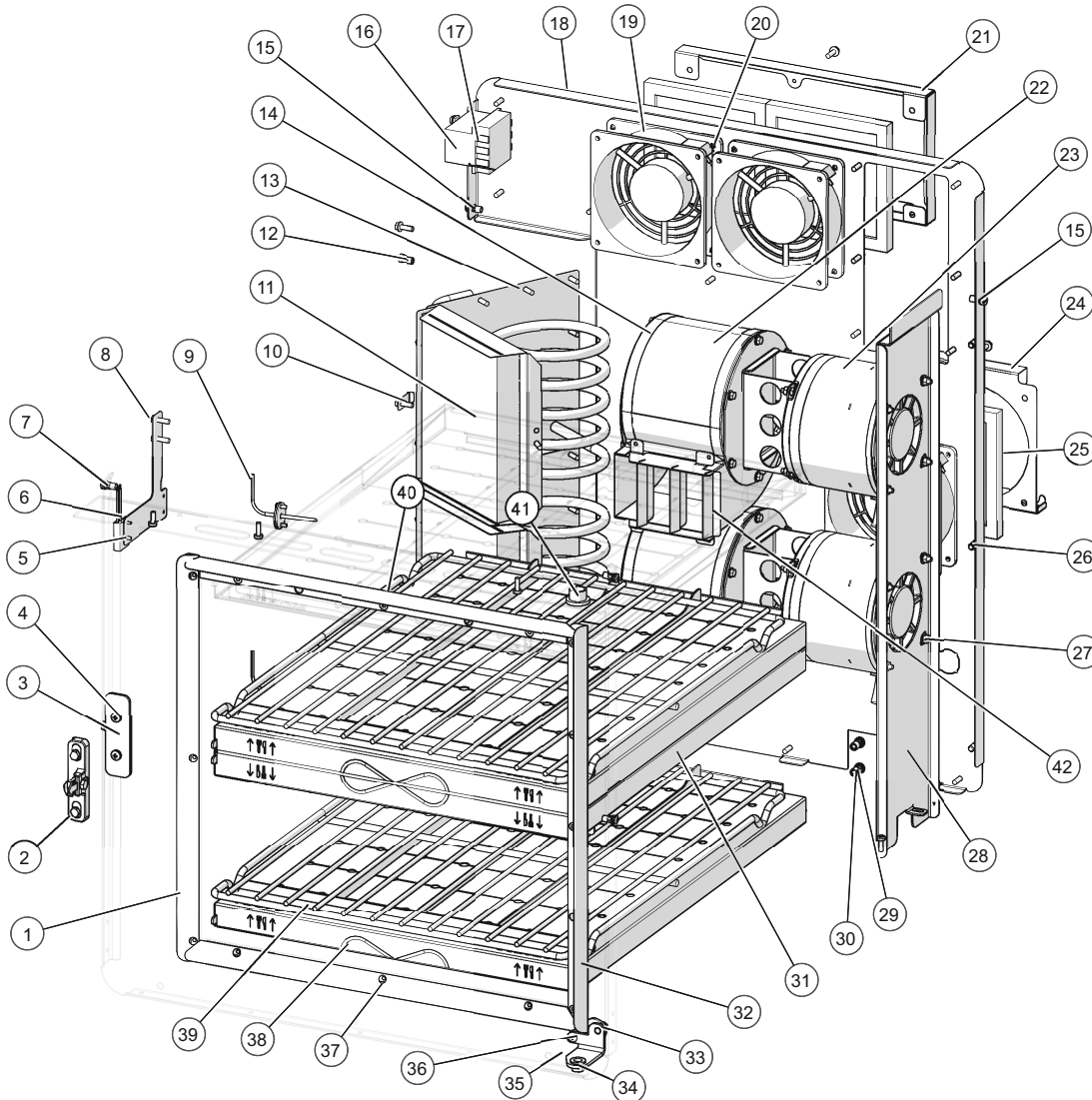

ID	Part No.	Description
1	1029220	SPRING FLANGE, LEFT DOOR
2	LT-39674	LATCH, STRIKE, DOOR, ADJUSTABLE
3	1031060	LATCH SPACER
4	SC-38887	SCREW, M5x0.8X1
5	SC-22268	SCREW, M3x0.5X8MM PAN
6	LT-3738	DOOR, INTERLOCK SWITCH
7	SC-22273	SCREW, M4x0.7X10MM PAN
8	1028110	BRKT, DOOR SWITCH, VOLPI H3HR
9	5028177	KIT, TEMP SENSOR/GASKET
10	1023476	BULB HOLDER, HIGH LIMIT
11	5026194	CATALYST, ASSEMBLY
12	NU-26866	NUT, HEX INSERT M4
13	EL-37664R	HEATER, COIL
14	HS-37633	INLET RING, 5D75
15	SC-46278	SCREW, M4X0.7, 4MM SHOULDER
16	SC-37701	SCREW, M4 X 8MM SEMS
17	TT-46376	THERMAL CUTOFF, MECHANICAL,
18	5027805	BACK SKIN ASSEMBLY
19	FA-36957	FAN, 230V, MECHATRONICS, HI-TEMP
20	SC-26520	SCREW, #10X1/2" HEX SERR FLG
21	1023498	HOLDER, FILTER, DOUBLE
22	HS-37631	BLOWER HOUSING, 350 MODEL X4.5"
23	5023985R	MOTOR, FAN, ASSEMBLY
24	1033662	FILTER HOLDER, SINGLE, HALF
25	FI-37700	FILTER, 5IN X 5IN
26	SC-37702	SCREW, M4 X 12MM SEMS
27	NU-39180	NUT, M4-0.7 HEX FLG-SERR CL8 SS
28	1029217	BRACKET, MOTOR SUPPORT VH2
29	SC-22766	SCREW, M5x0.8X10MM PAN
30	NU-23909	NUT, HEX INSERT M5
31	SC-39147	SCREW, 8-18 X .480 HEX WASHER
32	1029269	SPRING FLANGE, RIGHT DOOR
33	NU-38212	NUT, M5-0.8 HEX FLG-SERR CL8 SS
34	BU-37709	BUSHING, FLANGE, .312ID X .375
35	5027045	HINGE, LOWER ASSEM, H3HR
36	SC-22281	SCREW, M5x0.8X16MM FLAT
37	1028106	SPRING FLANGE, BOTTOM DOOR
38	5025235	JET PLATE ASSEMBLY, HALF
39	SH-37662	SHELF WIRE, COOK, RACKS
40	1028109	SPRING FLANGE, TOP DOOR
41	BU-39572	BUSHING, HINGE, DOOR
42	5023981	BLOWER BAFFLE ASSEMBLY
43	5024003	FILTER ASM, INTERNAL (1 set per chamber: not shown)
44	5024271	WIRE ASM, COOLING FAN (not shown)
45	CB-46358	CABLE, MOTOR DRIVE (not shown)

Core Components, H2 (LH)

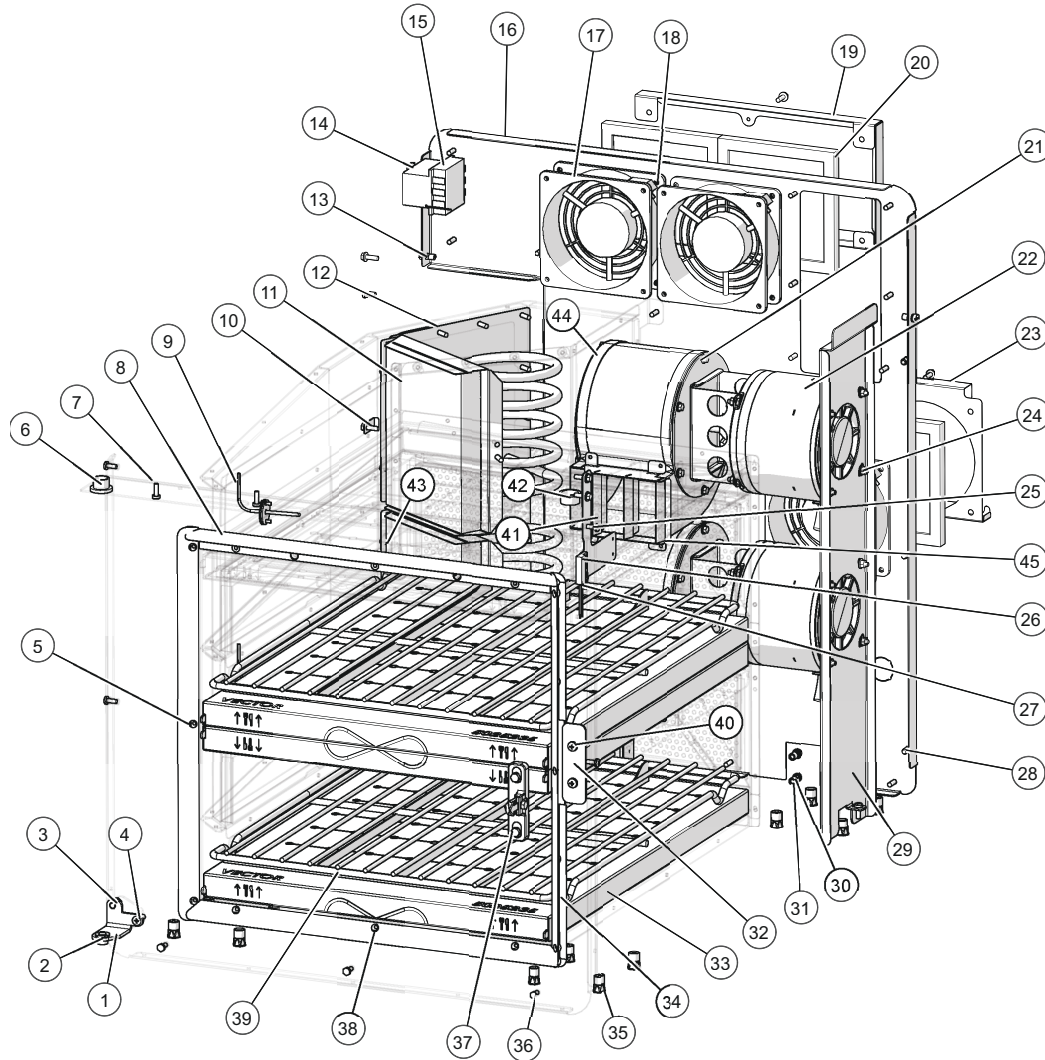

ID	Part No.	Description
1	5027569	ASSY, LOWER HINGE
2	BU-37709	BUSHING,FLANGE, .312ID X .375
3	NU-38212	NUT,M5-0.8 HEX FLG-SERR CL8 SS
4	SC-22281	SCREW,M5x0.8X16MM FLAT
5	1029220	SPRING FLANGE, LEFT DOOR
6	BU-39572	BUSHING,HINGE,DOOR
7	SC-37702	SCREW, M4 X 12MM SEMS
8	1028109	SPRING FLANGE, TOP DOOR
9	5028177	KIT, TEMP SENSOR/GASKET
10	1023476	BULB HOLDER, HIGH LIMIT
11	5026194	CATALYST, ASSEMBLY
12	EL-37664R	HEATER, COIL
13	SC-46278	SCREW,M4X0.7,4MM SHOULDER
14	SC-37701	SCREW, M4 X 8MM SEMS
15	TT-46376	THERMAL CUTOFF, MECHANICAL,
16	5027805	SKIN, BACK ASSEMBLY
17	FA-36957	FAN,230V,MECHATRONICS,HI-TEMP
18	SC-26520	SCREW, #10X1/2" HEX SERR FLG
19	1023498	HOLDER, FILTER, DOUBLE
20	FI-37700	FILTER, 5IN X 5IN
21	HS-37631	BLOWER HOUSING,350 MODEL X4.5"
22	5023985R	MOTOR,FAN,ASSEMBLY
23	1033662	FILTER HOLDER, SINGLE, HALF
24	NU-39180	NUT,M4-0.7 HEX FLG-SERR CL8 SS
25	SC-22273	SCREW,M4x0.7X10MM PAN
26	SC-22268	SCREW,M3x0.5X8MM PAN
27	LT-3738	DOOR, INTERLOCK SWITCH
28	NU-26866	NUT, HEX INSERT M4
29	1029217	BRACKET, MOTOR SUPPORT VH2
30	SC-22766	SCREW,M5x0.8X10MM PAN
31	NU-23909	NUT, HEX INSERT M5
32	1031060	LATCH SPACER
33	5025235	JET PLATE ASSEMBLY, HALF
34	1029221	SPRING FLANGE, LEFT DOOR
35	NU-28537	NUT, HEX INSERT M8
36	SC-23664	SCREW, M4x0.7x10MM HEX
37	LT-39674	LATCH,STRIKE,DOOR,ADJUSTABLE
38	1028106	SPRING FLANGE, BOTTOM DOOR
39	SH-37662	SHELF,WIRE,COOK,RACKS
40	SC-38887	SCREW,M5x0.8X16MM PAN
41	1028110	BRKT, DOOR SWITCH, VOLPI H3HR
42	BU-3008	3/4" WHITE SNAP BUSHING
43	SC-39147	SCREW, 8-18 X .480 HEX WASHER
44	HS-37633	INLET RING,5D75
45	5023981	BLOWER BAFFLE ASSEMBLY
46	5024003	FILTER ASM, INTERNAL (1 set per chamber; not shown)
47	5024271	WIRE ASM, COOLING FAN (not shown)
48	CB-46358	CABLE, MOTOR DRIVE (not shown)

Core Components, H2H (RH)

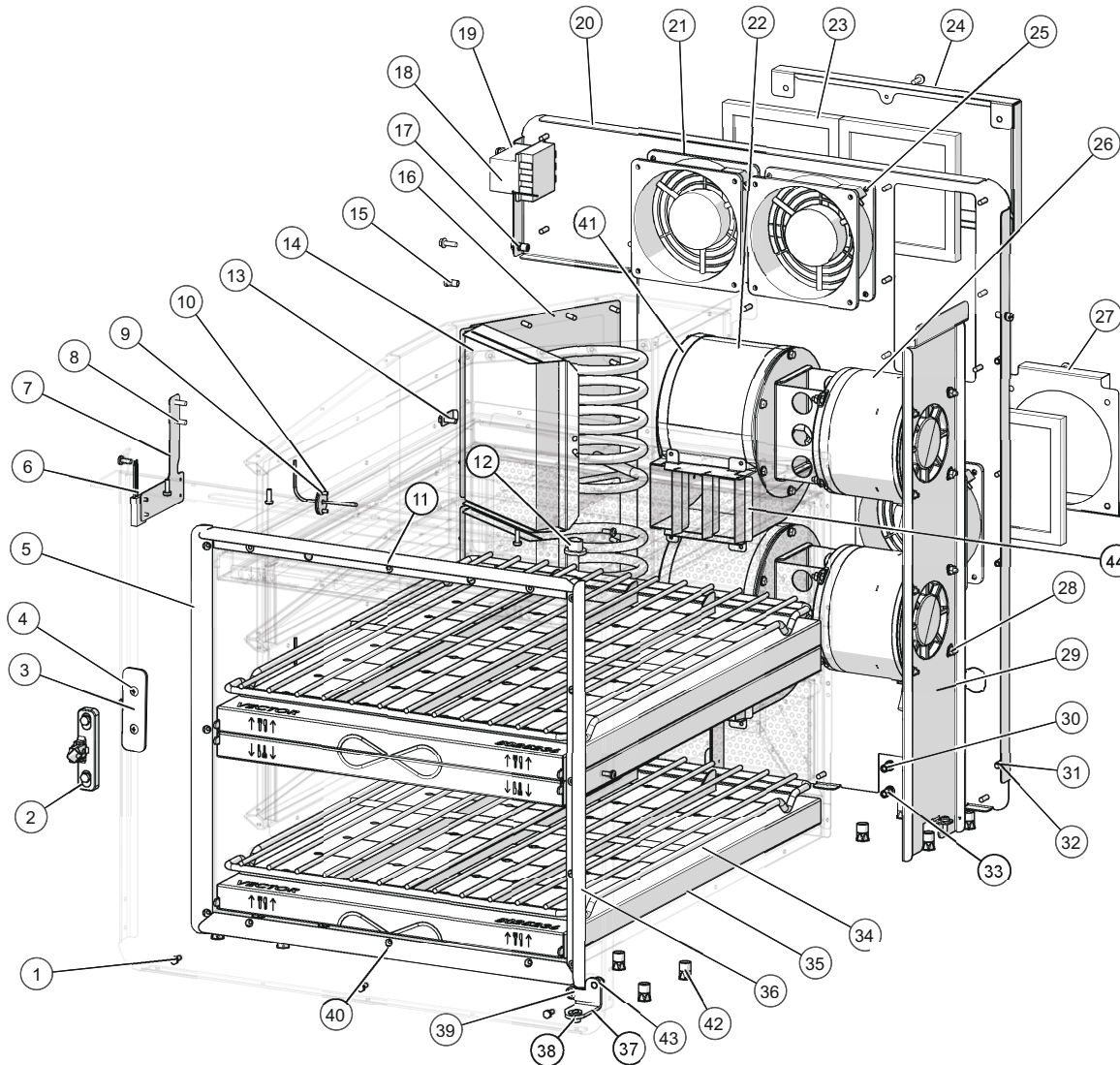

ID	Part No.	Description
1	SC-23664	SCREW, M4x0.7x10MM HEX
2	LT-39674	LATCH, STRIKE, DOOR, ADJUSTABLE
3	1031060	LATCH SPACER
4	SC-38887	SCREW, M5x0.8X16MM PAN
5	1029220	SPRING FLANGE, LEFT DOOR
6	LT-3738	DOOR, INTERLOCK SWITCH
7	1028110	BRKT, DOOR SWITCH, VOLPI H3HR
8	SC-39147	SCREW, 8-18 X .480 HEX WASHER
9	SC-22268	SCREW, M3x0.5X8MM PAN
10	5028177	KIT, TEMP SENSOR/GASKET
11	1028109	SPRING FLANGE, TOP DOOR
12	BU-39572	BUSHING, HINGE, DOOR
13	1023476	BULB HOLDER, HIGH LIMIT
14	5026194	CATALYST, ASSEMBLY
15	SC-22273	SCREW, M4x0.7X10MM PAN
16	EL-37664R	HEATER, COIL
17	SC-46278	SCREW, M4X0.7, 4MM SHOULDER
18	SC-37701	SCREW, M4 X 8MM SEMS
19	TT-46376	THERMAL CUTOFF, MECHANICAL,
20	5027805	SKIN, BACK ASSEMBLY
21	FA-36957	FAN, 230V, MECHATRONICS, HI-TEMP
22	HS-37631	BLOWER HOUSING, 350 MODEL X4.5"
23	FI-37700	FILTER, 5IN X 5IN
24	1023498	HOLDER, FILTER, DOUBLE
25	SC-26520	SCREW, #10X1/2" HEX SERR FLG
26	5023985R	MOTOR, FAN, ASSEMBLY
27	1033662	FILTER HOLDER, SINGLE, HALF
28	NU-39180	NUT, M4-0.7 HEX FLG-SERR CL8 SS
29	1029217	BRACKET, MOTOR SUPPORT VH2
30	NU-23909	NUT, HEX INSERT M5
31	SC-37702	SCREW, M4 X 12MM SEMS
32	NU-26866	NUT, HEX INSERT M4
33	SC-22766	SCREW, M5x0.8X10MM PAN
34	SH-39077	SHELF, WIRE COOK, RACK
35	5025236	JET PLATE ASSEMBLY, HOTEL
36	1029269	SPRING FLANGE, RIGHT DOOR
37	5027045	HINGE, LOWER ASSEM, H3HR
38	BU-37709	BUSHING, FLANGE, .312ID X .375
39	SC-22281	SCREW, M5x0.8X16MM FLAT
40	1028106	SPRING FLANGE, BOTTOM DOOR
41	HS-37633	INLET RING, 5D75
42	NU-28537	NUT, HEX INSERT M8
43	NU-38212	NUT, M5-0.8 HEX FLG-SERR CL8 SS
44	5023981	BLOWER BAFFLE ASSEM
45	5024003	FILTER ASM, INTERNAL (1 set/chamber; not show
46	5024271	WIRE ASM, COOLING FAN (not shown)
47	CB-46358	CABLE, MOTOR DRIVE (not shown)

Core Components, H2H (LH)

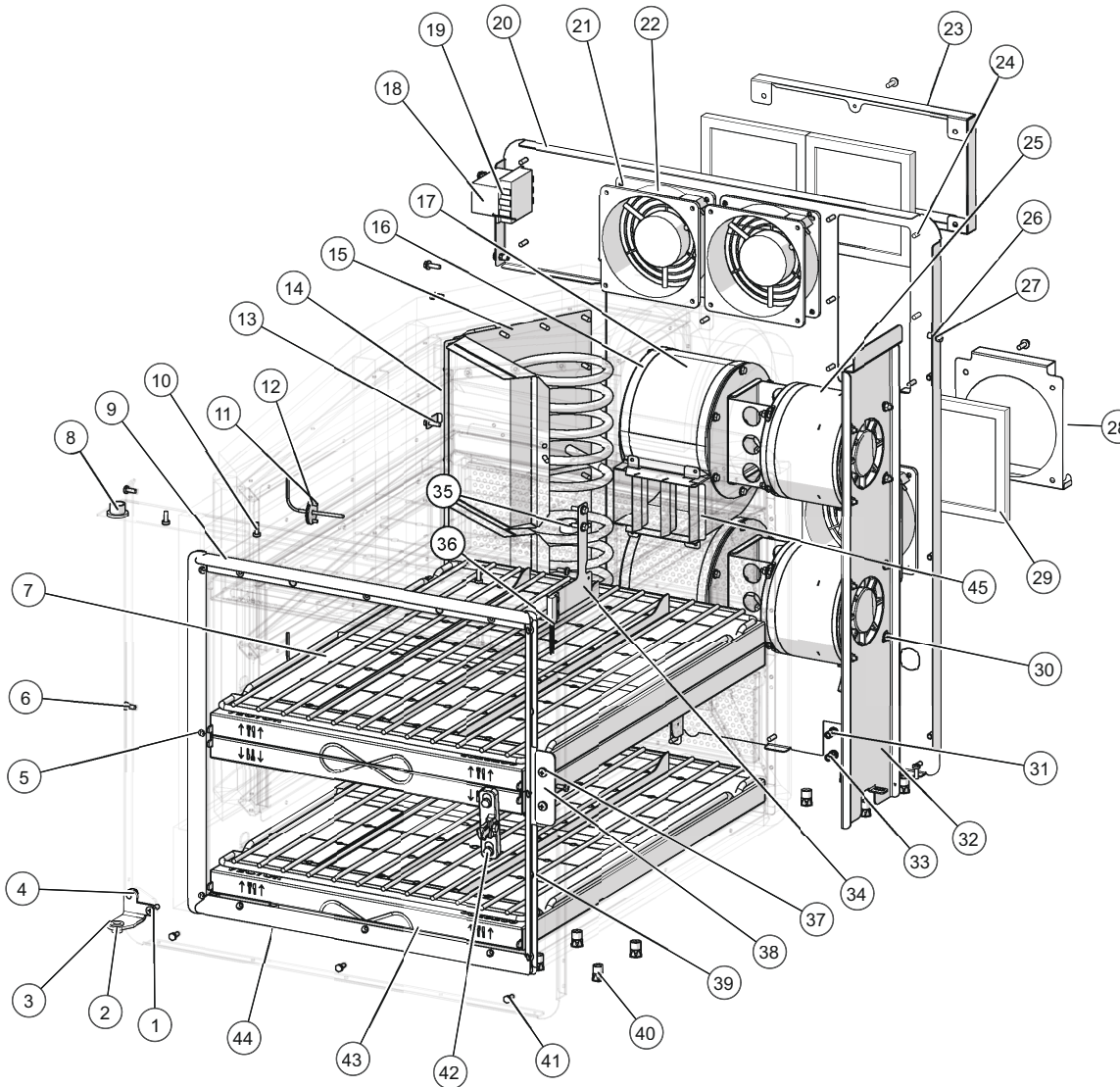

ID	Part No.	Description
1	SC-22281	SCREW,M5x0.8X16MM FLAT
2	BU-37709	BUSHING,FLANGE, .312ID X .375
3	5027569	ASSY, LOWER HINGE
4	NU-38212	NUT,M5-0.8 HEX FLG-SERR CL8 SS
5	1029220	SPRING FLANGE, LEFT DOOR
6	SC-22273	SCREW,M4x0.7X10MM PAN
7	SH-39077	SHELF, WIRE COOK, RACK
8	BU-39572	BUSHING,HINGE,DOOR
9	1028109	SPRING FLANGE, TOP DOOR
10	SC-37702	SCREW, M4 X 12MM SEMS
11	5028177	KIT, TEMP SENSOR/GASKET
12	SC-22268	SCREW,M3x0.5X8MM PAN
13	1023476	BULB HOLDER, HIGH LIMIT
14	5026194	CATALYST, ASSEMBLY
15	EL-37664R	HEATER, COIL
16	HS-37633	INLET RING,5D75
17	HS-37631	BLOWER HOUSING,350 MODEL X4.5"
18	SC-37701	SCREW, M4 X 8MM SEMS
19	TT-46376	THERMAL CUTOFF, MECHANICAL,
20	5027805	SKIN, BACK ASSEMBLY
21	SC-26520	SCREW, #10X1/2" HEX SERR FLG
22	FA-36957	FAN,230V,MECHATRONICS,HI-TEMP
23	1023498	HOLDER, FILTER, DOUBLE
24	SC-39147	SCREW, 8-18 X .480 HEX WASHER
25	5023985R	MOTOR,FAN,ASSEMBLY
26	NU-26866	NUT, HEX INSERT M4
27	SC-46278	SCREW,M4X0.7,4MM SHOULDER
28	1033662	FILTER HOLDER, SINGLE, HALF
29	FI-37700	FILTER, 5IN X 5IN
30	NU-39180	NUT,M4-0.7 HEX FLG-SERR CL8 SS
31	SC-22766	SCREW,M5x0.8X10MM PAN
32	1029217	BRACKET, MOTOR SUPPORT VH2
33	NU-23909	NUT, HEX INSERT M5
34	1028110	BRKT, DOOR SWITCH, VOLPI H3HR
35	BU-3008	3/4" WHITE SNAP BUSHING
36	LT-3738	DOOR, INTERLOCK SWITCH
37	SC-38887	SCREW,M5x0.8X16MM PAN
38	1031060	LATCH SPACER
39	1029221	SPRING FLANGE, LEFT DOOR
40	NU-28537	NUT, HEX INSERT M8
41	SC-23664	SCREW, M4x0.7x10MM HEX
42	LT-39674	LATCH,STRIKE,DOOR,ADJUSTABLE
43	5025236	JET PLATE ASSEMBLY, HOTEL
44	1028106	SPRING FLANGE, BOTTOM DOOR
45	5023981	BLOWER BAFFLE ASSEMBLY
46	5024003	FILTER ASM, INTERNAL (1/chamber; not show
47	5024271	WIRE ASM, COOLING FAN (not shown)
48	CB-46358	CABLE, MOTOR DRIVE (not shown)

Core Components, H3 (RH)

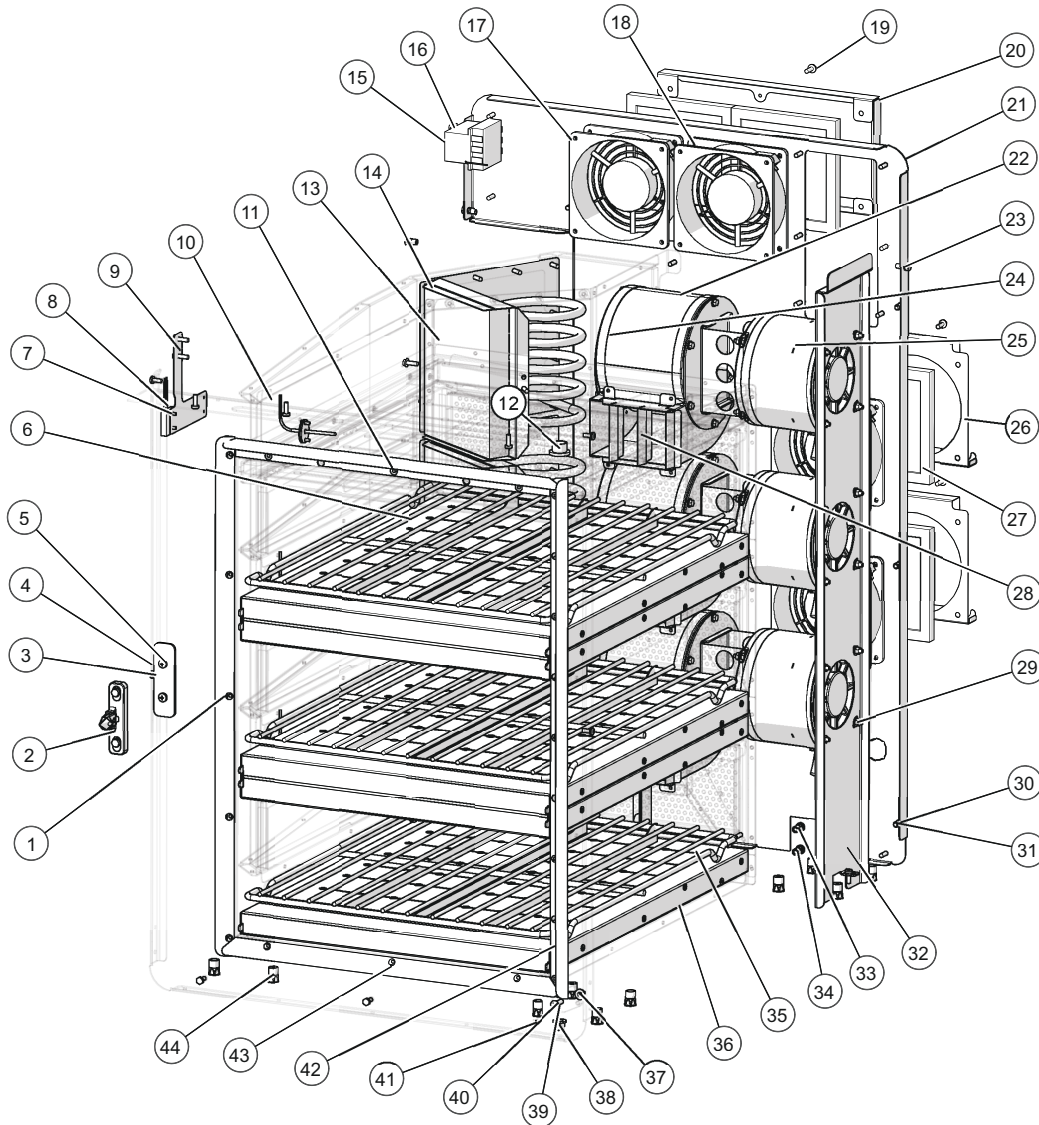

ID	Part No.	Description
1	1028107	SPRING FLANGE, LEFT DOOR
2	LT-39674	LATCH, STRIKE, DOOR, ADJUSTABLE
3	SC-22273	SCREW, M4x0.7x10MM PAN
4	1031060	LATCH SPACER
5	SC-38887	SCREW, M5x0.8x16MM PAN
6	1023476	BULB HOLDER, HIGH LIMIT
7	SC-22268	SCREW, M3x0.5x8MM PAN
8	LT-3738	DOOR, INTERLOCK SWITCH
9	1028110	BRKT, DOOR SWITCH, VOLPI H3HR
10	5028177	KIT, TEMP SENSOR/GASKET
11	1028109	SPRING FLANGE, TOP DOOR
12	BU-39572	BUSHING, HINGE, DOOR
13	5026194	CATALYST, ASSEMBLY
14	EL-37664R	HEATER, COIL
15	TT-46376	THERMAL CUTOFF, MECHANICAL,
16	SC-37701	SCREW, M4 X 8MM SEMS
17	FA-36957	FAN, 230V, MECHATRONICS, HI-TEMP
18	SC-26520	SCREW, #10X1/2" HEX SERR FLG
19	SC-39147	SCREW, 8-18 X .480 HEX WASHER
20	1023498	HOLDER, FILTER, DOUBLE
21	5033151	SKIN, BACK ASSEMBLY
22	HS-37631	BLOWER HOUSING, 350 MODEL X4.5"
23	SC-46278	SCREW, M4X0.7, 4MM SHOULDER
24	HS-37633	INLET RING, 5D75
25	5023985R	MOTOR, FAN, ASSEMBLY
26	1033662	FILTER HOLDER, SINGLE, HALF
27	FI-37700	FILTER, 5IN X 5IN
28	5023981	BLOWER BAFFLE ASSEMBLY
29	NU-39180	NUT, M4-0.7 HEX FLG-SERR CL8 SS
30	NU-26866	NUT, HEX INSERT M4
31	SC-37702	SCREW, M4 X 12MM SEMS
32	1028793	BRACKET, MOTOR SUPPORT H3
33	SC-22766	SCREW, M5x0.8x10MM PAN
34	NU-23909	NUT, HEX INSERT M5
35	SH-37662	SHELF, WIRE, COOK, RACKS
36	5025235	PLATE, JET, ASSEMBLY, HALF
37	NU-38212	NUT, M5-0.8 HEX FLG-SERR CL8 SS
38	BU-37709	BUSHING, FLANGE, .312ID X .375
39	5027045	HINGE, LOWER ASSEM, H3HR
40	SC-22281	SCREW, M5x0.8x16MM FLAT
41	SC-23664	SCREW, M4x0.7x10MM HEX
42	1028108	SPRING FLANGE, RIGHT DOOR
43	1028106	SPRING FLANGE, BOTTOM DOOR
44	NU-28537	NUT, HEX INSERT M8
45	5024003	FILTER ASM, INTERNAL (1 set/chamber; not shown)
46	5024271	WIRE ASM, COOLING FAN (not shown)
47	CB-46358	CABLE, MOTOR DRIVE (not shown)

Core Components, H3 (LH)

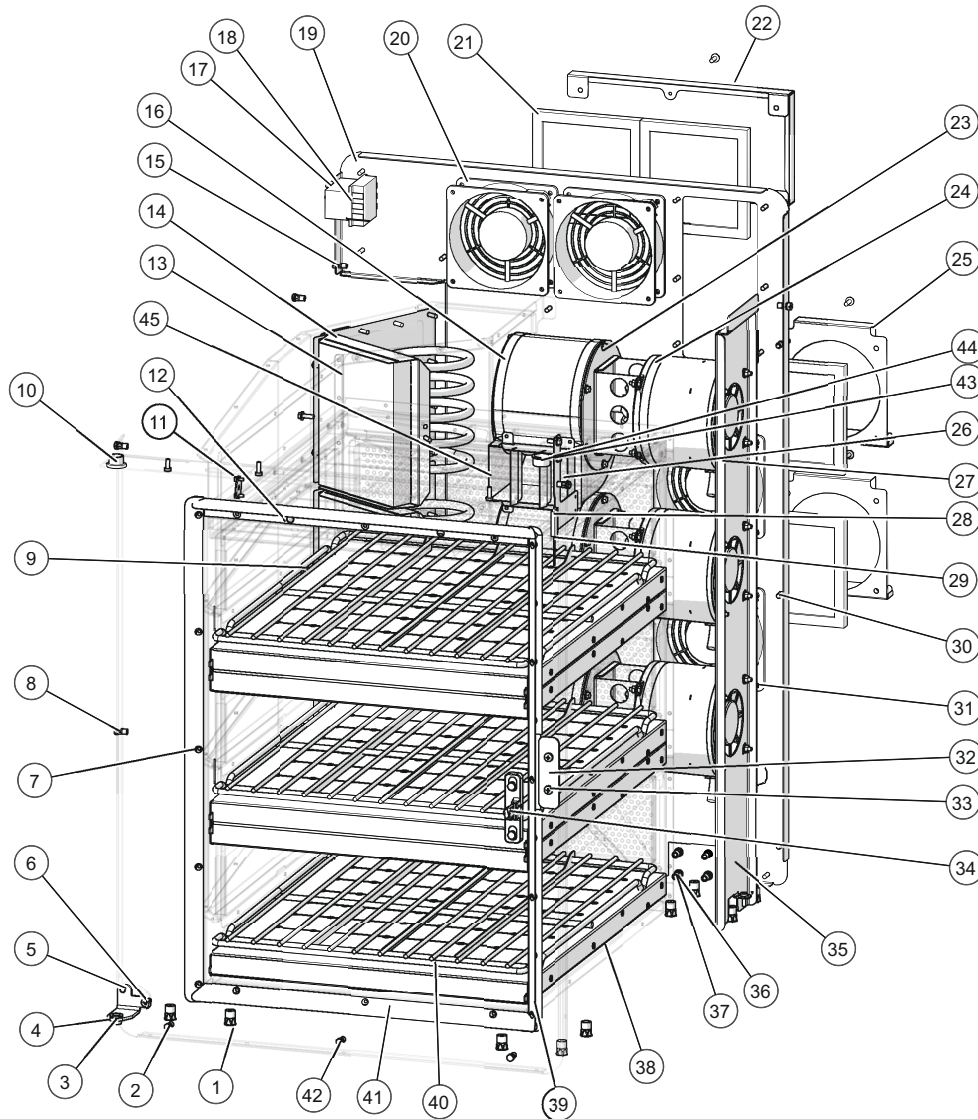

ID	Part No.	Description
1	NU-28537	NUT, HEX INSERT M8
2	NU-26866	NUT, HEX INSERT M4
3	BU-37709	BUSHING,FLANGE, .312ID X .375
4	5027569	ASSY, LOWER HINGE
5	NU-38212	NUT,M5-0.8 HEX FLG-SERR CL8 SS
6	SC-22281	SCREW,M5x0.8X16MM FLAT
7	1028107	SPRING FLANGE, LEFT DOOR
8	SC-22273	SCREW,M4x0.7X10MM PAN
9	1023476	BULB HOLDER, HIGH LIMIT
10	BU-39572	BUSHING,HINGE,DOOR
11	5028177	KIT, TEMP SENSOR/GASKET
12	1028109	SPRING FLANGE, TOP DOOR
13	5026194	CATALYST, ASSEMBLY
14	EL-37664R	HEATER, COIL
15	SC-46278	SCREW,M4X0.7,4MM SHOULDER
16	HS-37633	INLET RING,5D75
17	SC-37701	SCREW, M4 X 8MM SEMS
18	TT-46376	THERMAL CUTOFF, MECHANICAL,
19	5033151	SKIN, BACK ASSEMBLY
20	FA-36957	FAN,230V,MECHATRONICS,HI-TEMP
21	FI-37700	FILTER, 5IN X 5IN
22	1023498	HOLDER, FILTER, DOUBLE
23	HS-37631	BLOWER HOUSING,350 MODEL X4.5"
24	5023985R	MOTOR,FAN,ASSEMBLY
25	1033662	FILTER HOLDER, SINGLE, HALF
26	1028110	BRKT, DOOR SWITCH, VOLPI H3HR
27	NU-39180	NUT,M4-0.7 HEX FLG-SERR CL8 SS
28	SC-22268	SCREW,M3x0.5X8MM PAN
29	LT-3738	DOOR, INTERLOCK SWITCH
30	SC-37702	SCREW, M4 X 12MM SEMS
31	SC-26520	SCREW, #10X1/2" HEX SERR FLG
32	1031060	LATCH SPACER
33	SC-38887	SCREW,M5x0.8X16MM PAN
34	LT-39674	LATCH,STRIKE,DOOR,ADJUSTABLE
35	1028793	BRACKET, MOTOR SUPPORT H3
36	SC-22766	SCREW,M5x0.8X10MM PAN
37	NU-23909	NUT, HEX INSERT M5
38	5025235	PLATE, JET, ASSEMBLY, HALF
39	1028892	SPRING FLANGE, LEFT DOOR, H3L
40	SH-37662	SHELF,WIRE,COOK,RACKS
41	1028106	SPRING FLANGE, BOTTOM DOOR
42	SC-23664	SCREW, M4x0.7x10MM HEX
43	SC-39147	SCREW, 8-18 X .480 HEX WASHER
44	BU-3008	3/4" WHITE SNAP BUSHING
45	5023981	BLOWER BAFFLE ASSEMBLY
46	5024003	FILTER ASM, INTERNAL (1 set/chamber; not sho
47	5024271	WIRE ASM, COOLING FAN (not shown)
48	CB-46358	CABLE, MOTOR DRIVE (not shown)

Core Components, H3H (RH)

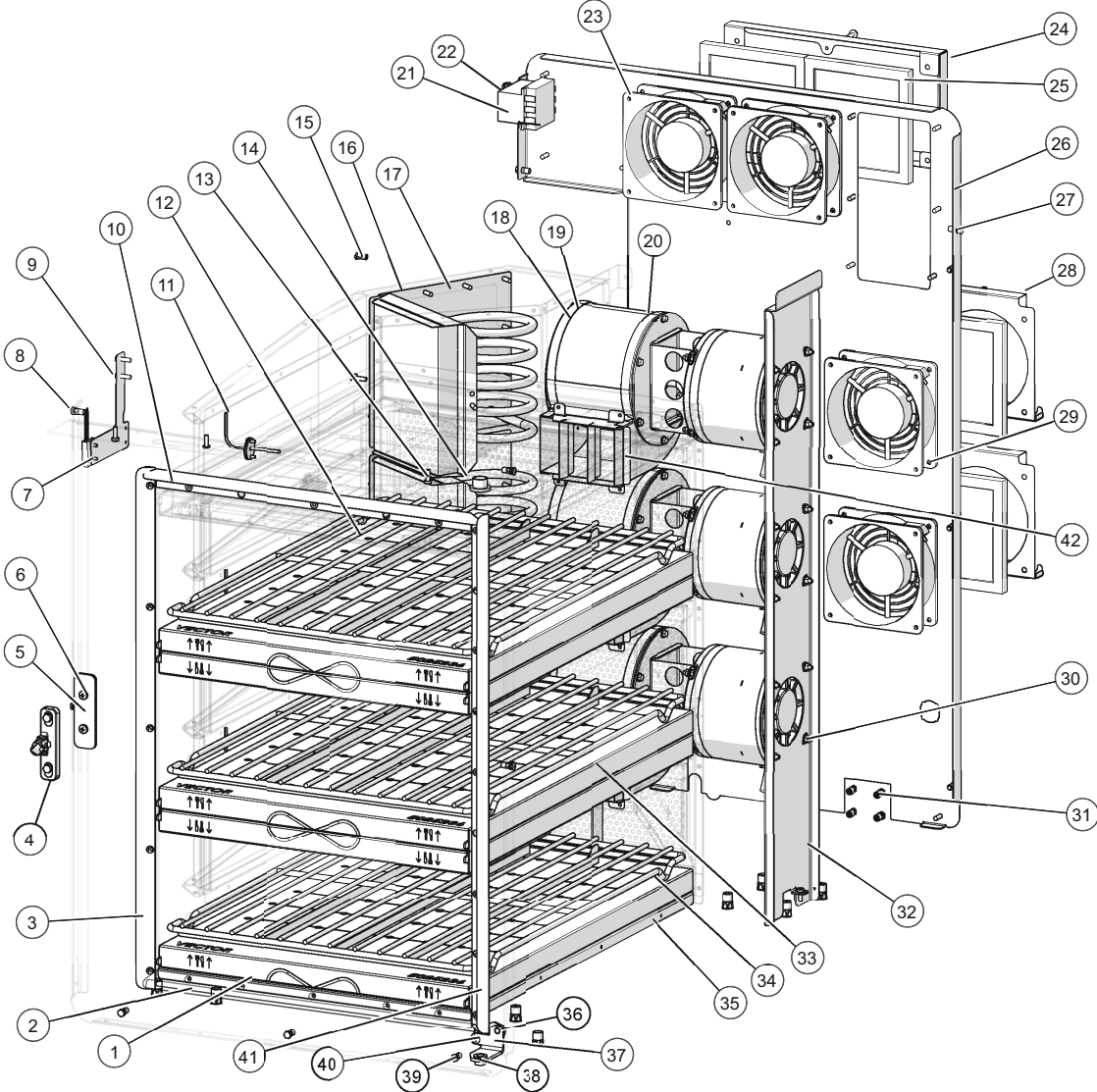

ID	Part No.	Description
1	NU-28537	NUT, HEX INSERT M8
2	1028106	SPRING FLANGE, BOTTOM DOOR
3	1028107	SPRING FLANGE, LEFT DOOR
4	LT-39674	LATCH, STRIKE, DOOR, ADJUSTABLE
5	1031060	LATCH SPACER
6	SC-38887	SCREW, M5x0.8X16MM PAN
7	SC-22268	SCREW, M3x0.5X8MM PAN
8	LT-3738	DOOR, INTERLOCK SWITCH
9	1028110	BRKT, DOOR SWITCH, VOLPI H3HR
10	1028109	SPRING FLANGE, TOP DOOR
11	5028177	KIT, TEMP SENSOR/GASKET
12	1023476	BULB HOLDER, HIGH LIMIT
13	SC-37702	SCREW, M4 X 12MM SEMS
14	BU-39572	BUSHING, HINGE, DOOR
15	NU-26866	NUT, HEX INSERT M4
16	5026194	CATALYST, ASSEMBLY
17	EL-37664R	HEATER, COIL
18	HS-37633	INLET RING, 5D75
19	HS-37631	BLOWER HOUSING, 350 MODEL X4.5"
20	5023985R	MOTOR, FAN, ASSEMBLY
21	SC-37701	SCREW, M4 X 8MM SEMS
22	TT-46376	THERMAL CUTOFF, MECHANICAL,
23	FA-36957	FAN, 230V, MECHATRONICS, HI-TEMP
24	1023498	HOLDER, FILTER, DOUBLE
25	FI-37700	FILTER, 5IN X 5IN
26	5033151	SKIN, BACK ASSEMBLY
27	SC-46278	SCREW, M4X0.7, 4MM SHOULDER
28	1033662	FILTER HOLDER, SINGLE, HALF
29	SC-26520	SCREW, #10X1/2" HEX SERR FLG
30	NU-39180	NUT, M4-0.7 HEX FLG-SERR CL8 SS
31	NU-23909	NUT, HEX INSERT M5
32	1028793	BRACKET, MOTOR SUPPORT H3
33	SC-39147	SCREW, 8-18 X .480 HEX WASHER
34	SH-39077	SHELF, WIRE COOK, RACK
35	5025236	JET PLATE ASSEMBLY, HOTEL
36	NU-38212	NUT, M5-0.8 HEX FLG-SERR CL8 SS
37	5027045	HINGE, LOWER ASSEM, H3HR
38	BU-37709	BUSHING, FLANGE, .312ID X .375
39	SC-23664	SCREW, M4x0.7x10MM HEX
40	SC-22281	SCREW, M5x0.8X16MM FLAT
41	1028108	SPRING FLANGE, RIGHT DOOR
42	5023981	BLOWER BAFFLE ASSEMBLY
43	5024003	FILTER ASM, INTERNAL (1 set/chamber; not show
44	5024271	WIRE ASM, COOLING FAN (not shown)
45	CB-46358	CABLE, MOTOR DRIVE (not shown)

Core Components, H3H (LH)

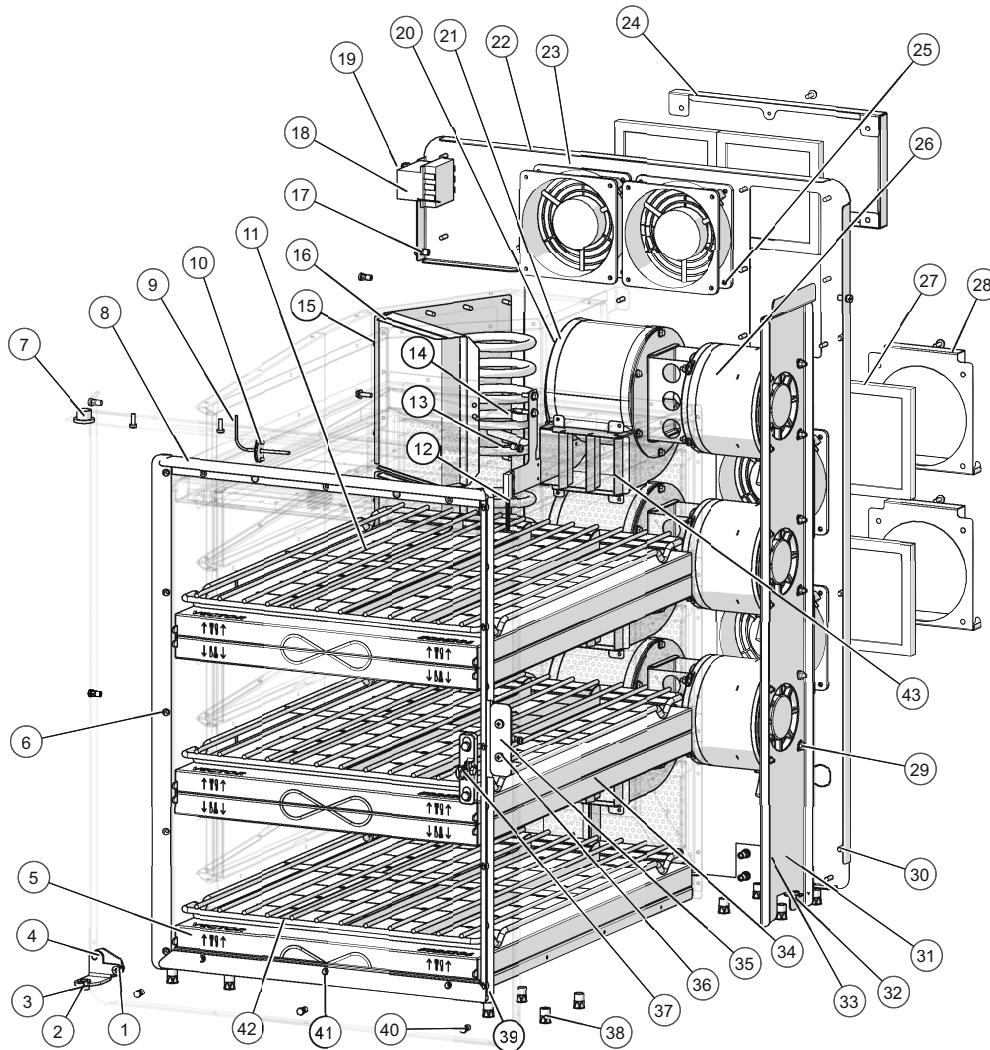

ID	Part No.	Description
1	SC-22281	SCREW,M5x0.8X16MM FLAT
2	BU-37709	BUSHING,FLANGE, .312ID X .375
3	5027569	ASSY, LOWER HINGE
4	NU-38212	NUT,M5-0.8 HEX FLG-SERR CL8 SS
5	5025236	JET PLATE ASSEMBLY, HOTEL
6	1028107	SPRING FLANGE, LEFT DOOR
7	BU-39572	BUSHING,HINGE,DOOR
8	1028109	SPRING FLANGE, TOP DOOR
9	5028177	KIT, TEMP SENSOR/GASKET
10	SC-22268	SCREW,M3x0.5X8MM PAN
11	1023476	BULB HOLDER, HIGH LIMIT
12	LT-3738	DOOR, INTERLOCK SWITCH
13	1028110	BRKT, DOOR SWITCH, VOLPI H3HR
14	BU-3008	3/4" WHITE SNAP BUSHING
15	5026194	CATALYST, ASSEMBLY
16	EL-37664R	HEATER, COIL
17	SC-46278	SCREW,M4X0.7.4MM SHOULDER
18	SC-37701	SCREW, M4 X 8MM SEMS
19	TT-46376	THERMAL CUTOFF, MECHANICAL,
20	HS-37633	INLET RING,5D75
21	HS-37631	BLOWER HOUSING,350 MODEL X4.5"
22	5033151	SKIN, BACK ASSEMBLY
23	FA-36957	FAN,230V,MECHATRONICS,HI-TEMP
24	1023498	HOLDER, FILTER, DOUBLE
25	SC-26520	SCREW, #10X1/2" HEX SERR FLG
26	5023985R	MOTOR,FAN,ASSEMBLY
27	FI-37700	FILTER, 5IN X 5IN
28	1033662	FILTER HOLDER, SINGLE, HALF
29	NU-39180	NUT,M4-0.7 HEX FLG-SERR CL8 SS
30	NU-26866	NUT, HEX INSERT M4
31	1028793	BRACKET, MOTOR SUPPORT H3
32	SC-37702	SCREW, M4 X 12MM SEMS
33	NU-23909	NUT, HEX INSERT M5
34	SC-39147	SCREW, 8-18 X .480 HEX WASHER
35	1031060	LATCH SPACER
36	SC-38887	SCREW,M5x0.8X16MM PAN
37	LT-39674	LATCH,STRIKE,DOOR,ADJUSTABLE
38	NU-28537	NUT, HEX INSERT M8
39	1028892	SPRING FLANGE, LEFT DOOR, H3L
40	SC-23664	SCREW, M4x0.7x10MM HEX
41	1028106	SPRING FLANGE, BOTTOM DOOR
42	SH-39077	SHELF, WIRE COOK, RACK
43	5023981	BLOWER BAFFLE ASSEM
44	5024003	FILTER ASM, INTERNAL (1 set/chamber; not shown)
45	5024271	WIRE ASM, COOLING FAN (not shown)
46	CB-46358	CABLE, MOTOR DRIVE (not shown)

Core Components, H4 (RH)

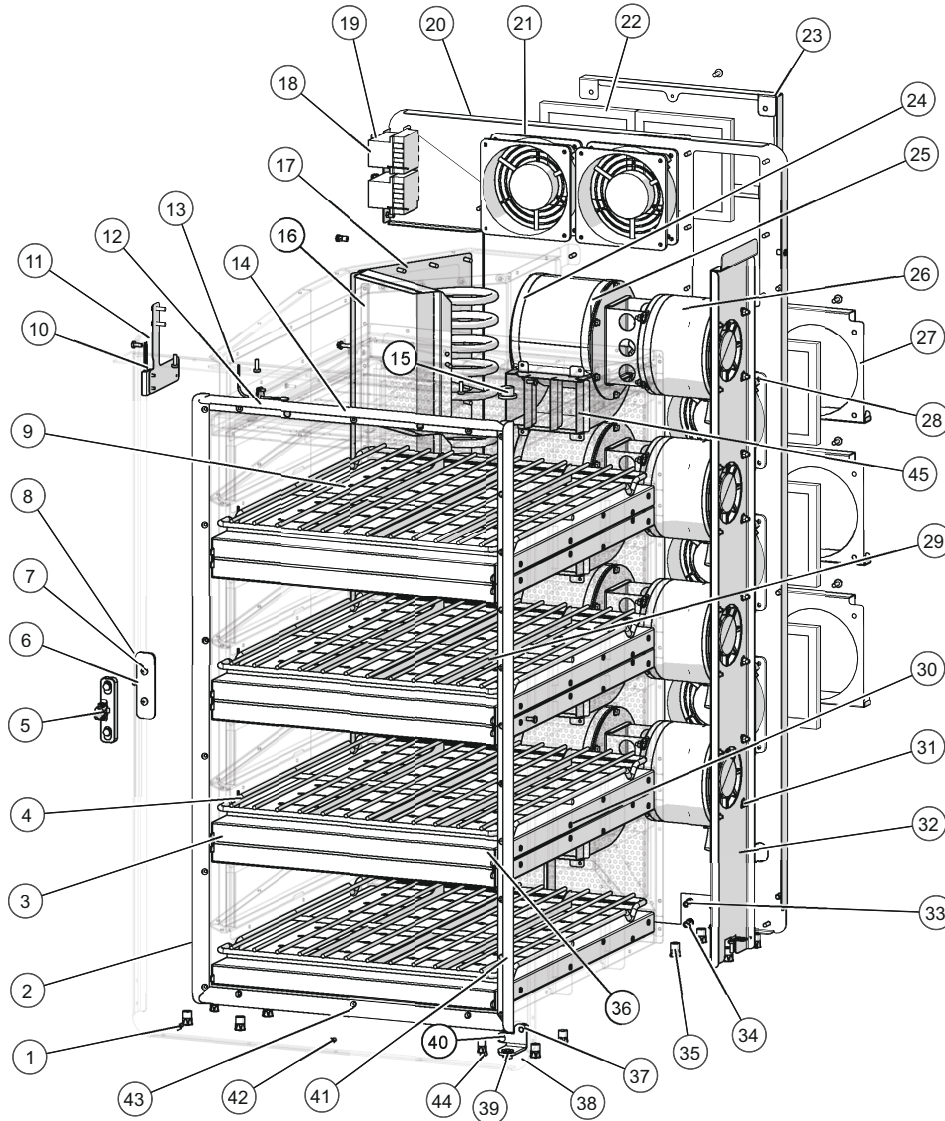

ID	Part No.	Description
1	SC-23664	SCREW, M4x0.7x10MM HEX
2	1028917	SPRING FLANGE, LEFT DOOR
3	5025235	PLATE, JET, ASSEMBLY, HALF
4	SH-37662	SHELF,WIRE,COOK,RACKS
5	LT-39674	LATCH,STRIKE,DOOR,ADJUSTABLE
6	SC-22273	SCREW,M4x0.7X10MM PAN
7	SC-38887	SCREW,M5x0.8X16MM PAN
8	1031060	LATCH SPACER
9	1023476	BULB HOLDER, HIGH LIMIT
10	LT-3738	DOOR, INTERLOCK SWITCH
11	1028110	BRKT, DOOR SWITCH, VOLPI H3HR
12	SC-22268	SCREW,M3x0.5X8MM PAN
13	5028177	KIT, TEMP SENSOR/GASKET
14	1028109	SPRING FLANGE, TOP DOOR
15	BU-39572	BUSHING,HINGE,DOOR
16	5026194	CATALYST, ASSEMBLY
17	EL-37664R	HEATER, COIL
18	TT-46376	THERMAL CUTOFF, MECHANICAL,
19	SC-37701	SCREW, M4 X 8MM SEMS
20	5033153	SKIN, BACK ASSEMBLY
21	FA-36957	FAN,230V,MECHATRONICS,HI-TEMP
22	FI-37700	FILTER, 5IN X 5IN
23	1023498	HOLDER, FILTER, DOUBLE
24	HS-37633	INLET RING,5D75
25	HS-37631	BLOWER HOUSING,350 MODEL X4.5"
26	5023985R	MOTOR,FAN,ASSEMBLY
27	1033662	FILTER HOLDER, SINGLE, HALF
28	SC-26520	SCREW, #10X1/2" HEX SERR FLG
29	NU-26866	NUT, HEX INSERT M4
30	SC-39147	SCREW, 8-18 X .480 HEX WASHER
31	NU-39180	NUT,M4-0.7 HEX FLG-SERR CL8 SS
32	1028987	BRACKET, MOTOR SUPPORT H4
33	NU-23909	NUT, HEX INSERT M5
34	SC-22766	SCREW,M5x0.8X10MM PAN
35	NU-28537	NUT, HEX INSERT M8
36	SC-37702	SCREW, M4 X 12MM SEMS
37	NU-38212	NUT,M5-0.8 HEX FLG-SERR CL8 SS
38	5027045	HINGE, LOWER ASSEM, H3HR
39	BU-37709	BUSHING,FLANGE, .312ID X .375
40	SC-22281	SCREW,M5x0.8X16MM FLAT
41	1028918	SPRING FLANGE, RIGHT DOOR
42	SC-23664	SCREW, M4x0.7x10MM HEX
43	1028106	SPRING FLANGE, BOTTOM DOOR
44	SC-23664	SCREW, M4x0.7x10MM HEX
45	5023981	BLOWER BAFFLE ASSEM
46	5024003	FILTER ASM, INTERNAL (1 set/chamber; not shown)
47	5024271	WIRE ASM, COOLING FAN (not shown)
48	CB-46358	CABLE, MOTOR DRIVE (not shown)

Core Components, H4 (LH)

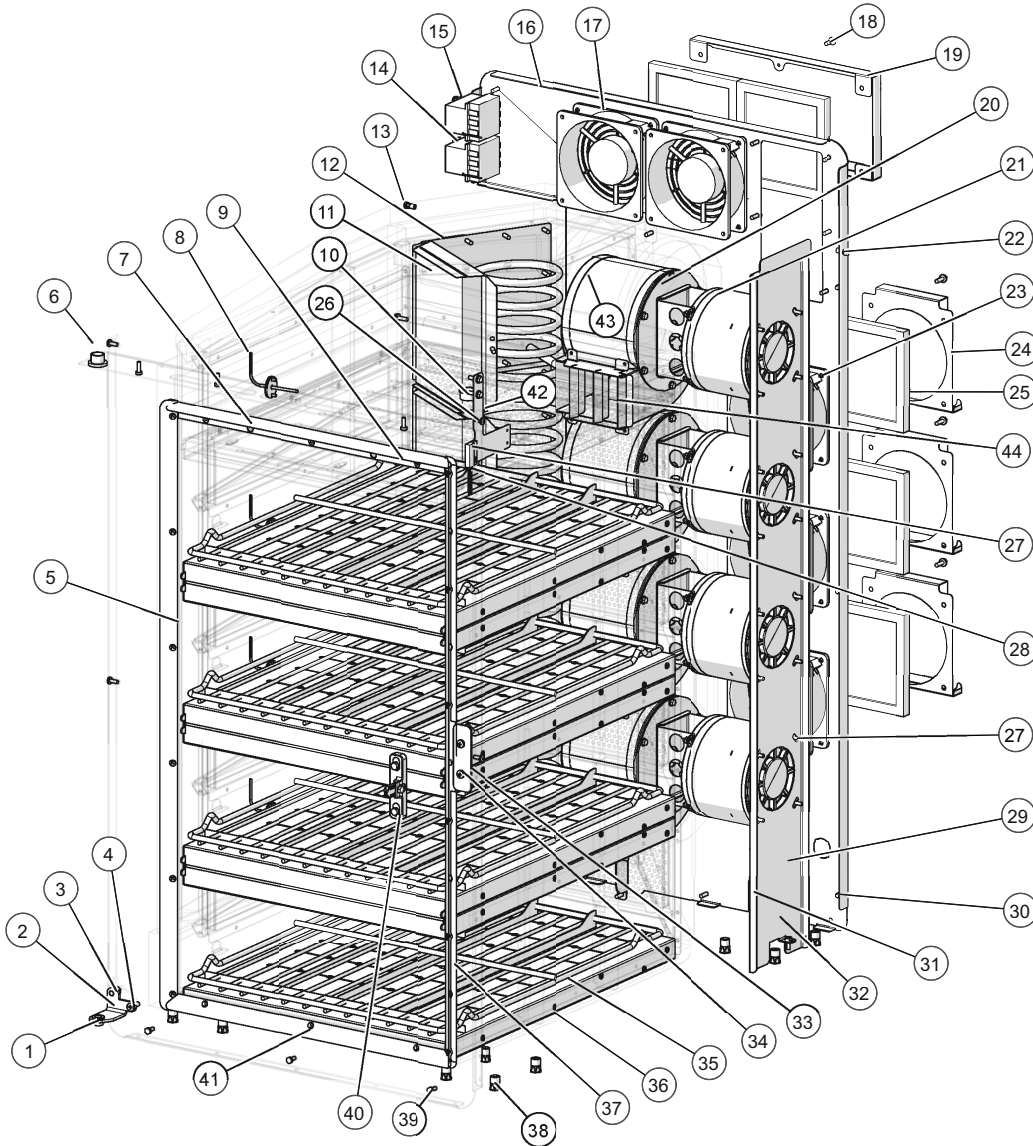

ID	Part No.	Description
1	BU-37709	BUSHING,FLANGE, .312ID X .375
2	5027569	ASSY, LOWER HINGE
3	NU-38212	NUT,M5-0.8 HEX FLG-SERR CL8 SS
4	SC-22281	SCREW,M5x0.8X16MM FLAT
5	1028917	SPRING FLANGE, LEFT DOOR
6	BU-39572	BUSHING,HINGE,DOOR
7	1028109	SPRING FLANGE, TOP DOOR
8	5028177	KIT, TEMP SENSOR/GASKET
9	1023476	BULB HOLDER, HIGH LIMIT
10	BU-3008	3/4" WHITE SNAP BUSHING
11	5026194	CATALYST, ASSEMBLY
12	EL-37664R	HEATER, COIL
13	NU-26866	NUT, HEX INSERT M4
14	SC-37701	SCREW, M4 X 8MM SEMS
15	TT-46376	THERMAL CUTOFF, MECHANICAL,
16	5033153	SKIN, BACK ASSEMBLY
17	FA-36957	FAN,230V,MECHATRONICS,HI-TEMP
18	SC-39147	SCREW, 8-18 X .480 HEX WASHER
19	1023498	HOLDER, FILTER, DOUBLE
20	HS-37631	BLOWER HOUSING,350 MODEL X4.5"
21	5023985R	MOTOR,FAN,ASSEMBLY
22	SC-46278	SCREW,M4X0.7,4MM SHOULDER
23	SC-26520	SCREW, #10X1/2" HEX SERR FLG
24	1033662	FILTER HOLDER, SINGLE, HALF
25	FI-37700	FILTER, 5IN X 5IN
26	SC-22273	SCREW,M4x0.7X10MM PAN
27	SC-22268	SCREW,M3x0.5X8MM PAN
28	LT-3738	DOOR, INTERLOCK SWITCH
29	1028987	BRACKET, MOTOR SUPPORT H4
30	SC-37702	SCREW, M4 X 12MM SEMS
31	NU-23909	NUT, HEX INSERT M5
32	SC-22766	SCREW,M5x0.8X10MM PAN
33	1031060	LATCH SPACER
34	SC-38887	SCREW,M5x0.8X16MM PAN
35	SH-37662	SHELF,WIRE,COOK,RACKS
36	5025235	PLATE, JET, ASSEMBLY, HALF
37	1029079	SPRING FLANGE, LEFT DOOR
38	NU-28537	NUT, HEX INSERT M8
39	SC-23664	SCREW, M4x0.7x10MM HEX
40	LT-39674	LATCH,STRIKE,DOOR,ADJUSTABLE
41	1028106	SPRING FLANGE, BOTTOM DOOR
42	1028110	BRKT, DOOR SWITCH, VOLPI H3HR
43	HS-37633	INLET RING,5D75
44	5023981	BLOWER BAFFLE ASSEM
45	5024003	FILTER ASM, INTERNAL (1 set/chamber; not shown)
46	5024271	WIRE ASM, COOLING FAN (not shown)
47	CB-46358	CABLE, MOTOR DRIVE (not shown)

Core Components, H4H (RH)

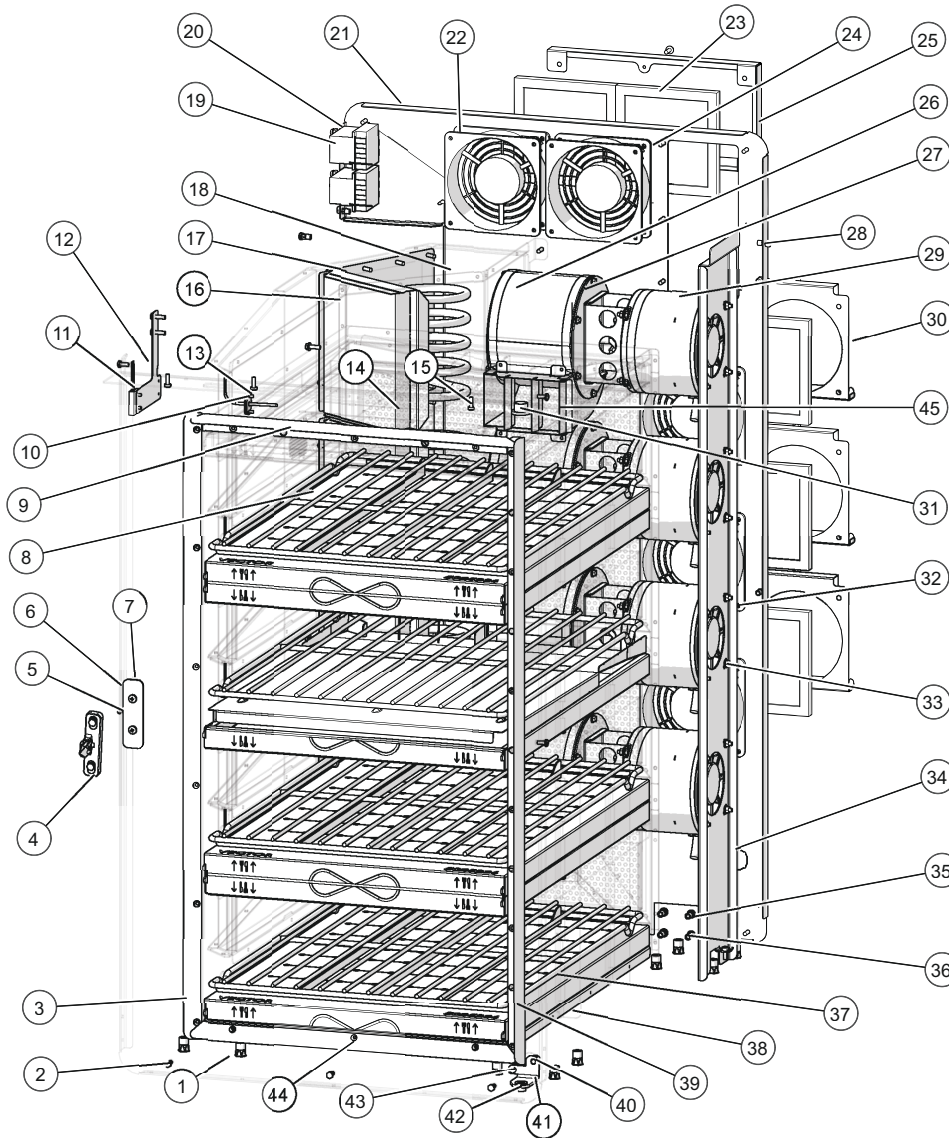

ID	Part No.	Description
1	NU-28537	NUT, HEX INSERT M8
2	SC-23664	SCREW, M4x0.7x10MM HEX
3	1028917	SPRING FLANGE, LEFT DOOR
4	LT-39674	LATCH, STRIKE, DOOR, ADJUSTABLE
5	SC-22273	SCREW, M4x0.7X10MM PAN
6	1031060	LATCH SPACER
7	SC-38887	SCREW, M5x0.8X1
8	1023476	BULB HOLDER, HIGH LIMIT
9	1028109	SPRING FLANGE, TOP DOOR
10	SC-22268	SCREW, M3x0.5X8MM PAN
11	LT-3738	DOOR, INTERLOCK SWITCH
12	1028110	BRKT, DOOR SWITCH, VOLPI H3HR
13	5028177	KIT, TEMP SENSOR/GASKET
14	SC-39147	SCREW, 8-18 X .480 HEX WASHER
15	SC-37702	SCREW, M4 X 12MM SEMS
16	5026194	CATALYST, ASSEMBLY
17	EL-37664R	HEATER, COIL
18	NU-26866	NUT, HEX INSERT M4
19	TT-46376	THERMAL CUTOFF, MECHANICAL,
20	SC-37701	SCREW, M4 X 8MM SEMS
21	5033153	SKIN, BACK ASSEMBLY
22	SC-26520	SCREW, #10X1/2" HEX SERR FLG
23	FI-37700	FILTER, 5IN X 5IN
24	FA-36957	FAN, 230V, MECHATRONICS, HI-TEMP
25	1023498	HOLDER, FILTER, DOUBLE
26	HS-37633	INLET RING, 5D75
27	HS-37631	BLOWER HOUSING, 350 MODEL X4.5"
28	SC-46278	SCREW, M4X0.7, 4MM SHOULDER
29	5023985R	MOTOR, FAN, ASSEMBLY
30	1033662	FILTER HOLDER, SINGLE, HALF
31	BU-39572	BUSHING, HINGE, DOOR
32	SC-26520	SCREW, #10X1/2" HEX SERR FLG
33	NU-39180	NUT, M4-0.7 HEX FLG-SERR CL8 SS
34	1028987	BRACKET, MOTOR SUPPORT H4
35	NU-23909	NUT, HEX INSERT M5
36	SC-22766	SCREW, M5x0.8X10MM PAN
37	SH-39077	SHELF, WIRE COOK, RACK
38	5025236	JET PLATE ASSEMBLY, HOTEL
39	1028918	SPRING FLANGE, RIGHT DOOR
40	NU-38212	NUT, M5-0.8 HEX FLG-SERR CL8 SS
41	5027045	HINGE, LOWER ASSEM, H3HR
42	BU-37709	BUSHING, FLANGE, .312ID X .375
43	SC-22281	SCREW, M5x0.8X16MM FLAT
44	1028106	SPRING FLANGE, BOTTOM DOOR
45	5023981	BLOWER BAFFLE ASSEM
46	5024003	FILTER ASM, INTERNAL (1 set/chamber; not shown)
47	5024271	WIRE ASM, COOLING FAN (not shown)
48	CB-46358	CABLE, MOTOR DRIVE (not shown)

Core Components, H4H (LH)

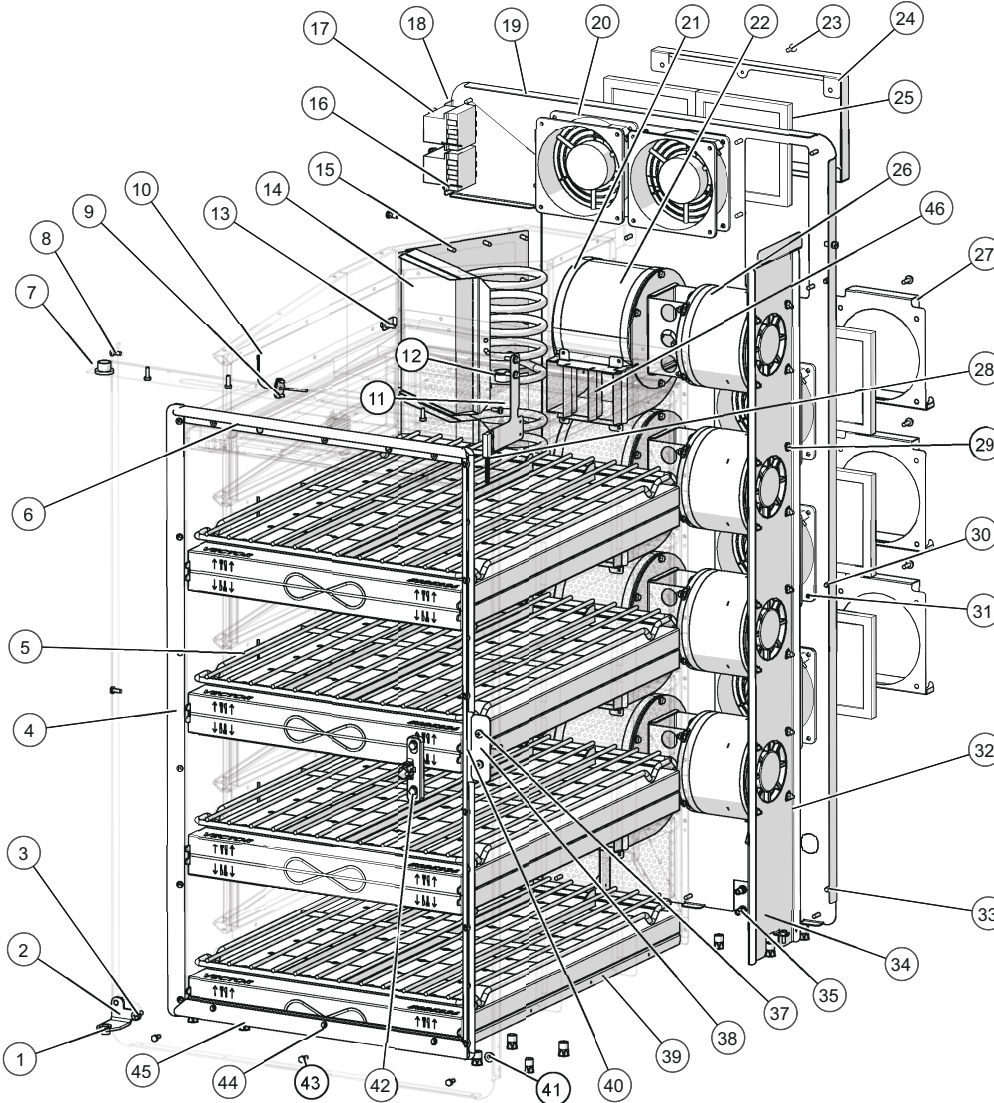

ID	Part No.	Description
1	BU-37709	BUSHING,FLANGE, .312ID X .375
2	5027569	ASSY, LOWER HINGE
3	SC-22281	SCREW,M5x0.8X16MM FLAT
4	1028917	SPRING FLANGE, LEFT DOOR
5	SH-39077	SHELF, WIRE COOK, RACK
6	1028109	SPRING FLANGE, TOP DOOR
7	BU-39572	BUSHING,HINGE,DOOR
8	SC-22273	SCREW,M4x0.7X10MM PAN
9	SC-22268	SCREW,M3x0.5X8MM PAN
10	5028177	KIT, TEMP SENSOR/GASKET
11	1028110	BRKT, DOOR SWITCH, VOLPI H3HR
12	BU-3008	3/4" WHITE SNAP BUSHING
13	1023476	BULB HOLDER, HIGH LIMIT
14	5026194	CATALYST, ASSEMBLY
15	EL-37664R	HEATER, COIL
16	SC-46278	SCREW,M4X0.7,4MM SHOULDER
17	SC-37701	SCREW, M4 X 8MM SEMS
18	TT-46376	THERMAL CUTOFF, MECHANICAL,
19	5033153	SKIN, BACK ASSEMBLY
20	FA-36957	FAN,230V,MECHATRONICS,HI-TEMP
21	HS-37633	INLET RING,5D75
22	HS-37631	BLOWER HOUSING,350 MODEL X4.5"
23	SC-39147	SCREW, 8-18 X .480 HEX WASHER
24	1023498	HOLDER, FILTER, DOUBLE
25	FI-37700	FILTER, 5IN X 5IN
26	5023985R	MOTOR,FAN,ASSEMBLY
27	1033662	FILTER HOLDER, SINGLE, HALF
28	LT-3738	DOOR, INTERLOCK SWITCH
29	NU-39180	NUT,M4-0.7 HEX FLG-SERR CL8 SS
30	SC-37702	SCREW, M4 X 12MM SEMS
31	SC-26520	SCREW, #10X1/2" HEX SERR FLG
32	1028987	BRACKET, MOTOR SUPPORT H4
33	NU-26866	NUT, HEX INSERT M4
34	NU-23909	NUT, HEX INSERT M5
35	SC-22766	SCREW,M5x0.8X10MM PAN
37	1031060	SCREW,M5x0.8X16MM PAN
38	5025236	LATCH SPACER
39	5025236	JET PLATE ASSEMBLY, HOTEL
40	1029079	SPRING FLANGE, LEFT DOOR
41	NU-38212	NUT,M5-0.8 HEX FLG-SERR CL8 SS
42	LT-39674	LATCH,STRIKE,DOOR,ADJUSTABLE
43	SC-23664	SCREW, M4x0.7x10MM HEX
44	1028106	SPRING FLANGE, BOTTOM DOOR
45	NU-28537	NUT, HEX INSERT M8
46	5023981	BLOWER BAFFLE ASSEMBLY
47	5024003	FILTER ASM, INTERNAL (1 set/chamber; not shown)
48	5024271	WIRE ASM, COOLING FAN (not shown)
49	CB-46358	CABLE, MOTOR DRIVE (not shown)

Motor/Fan Assembly (All Models)

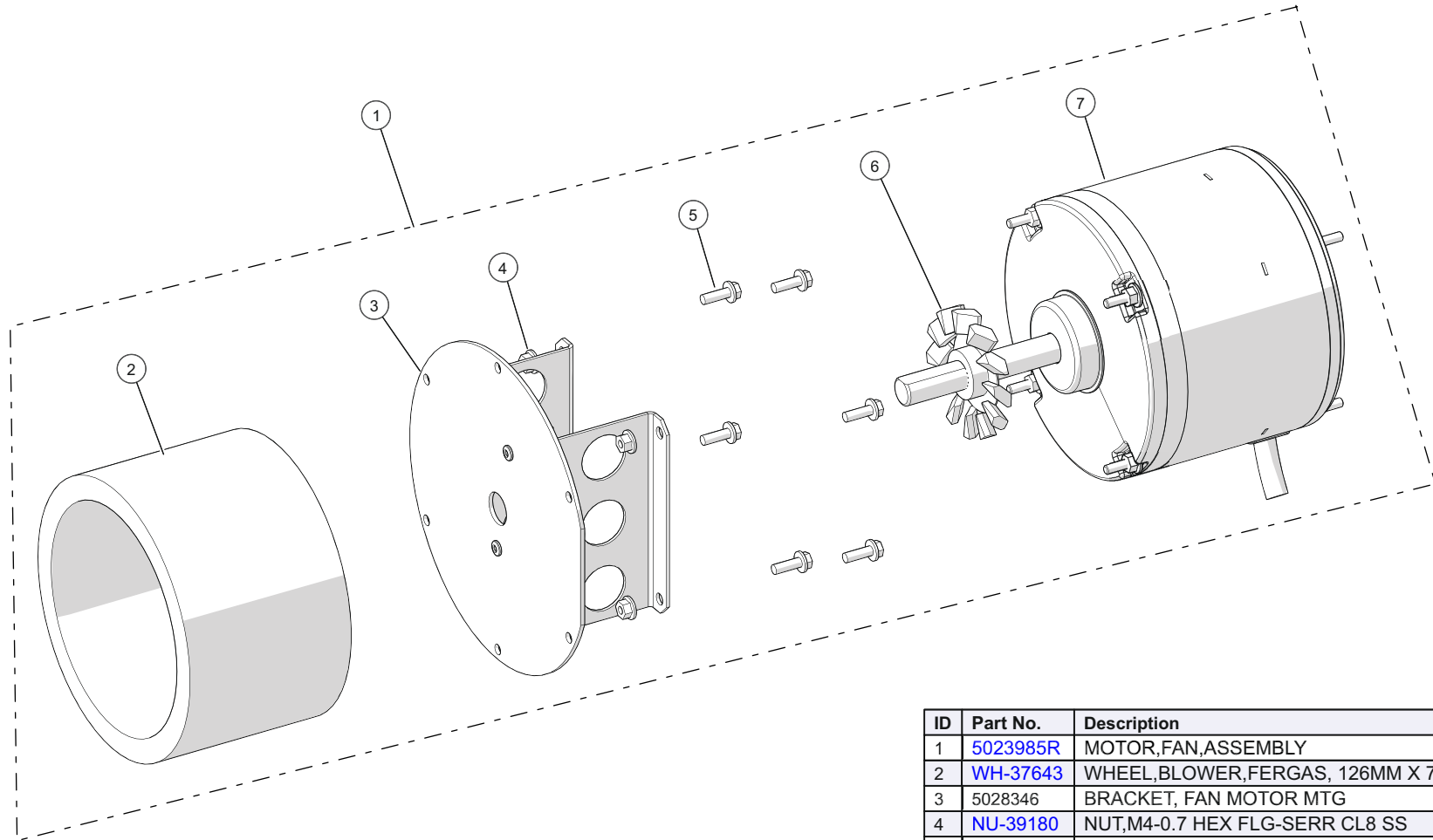

ID	Part No.	Description
1	5023985R	MOTOR,FAN,ASSEMBLY
2	WH-37643	WHEEL,BLOWER,FERGAS, 126MM X 7
3	5028346	BRACKET, FAN MOTOR MTG
4	NU-39180	NUT,M4-0.7 HEX FLG-SERR CL8 SS
5	SC-39147	SCREW, 8-18 X .480 HEX WASHER
6	WH-37632	RADIAL BLOWER WHEEL, R-STYLE W
7	MO-39010	MOTOR,TELCO_SINGLE_SHAFT

Casters and Feet

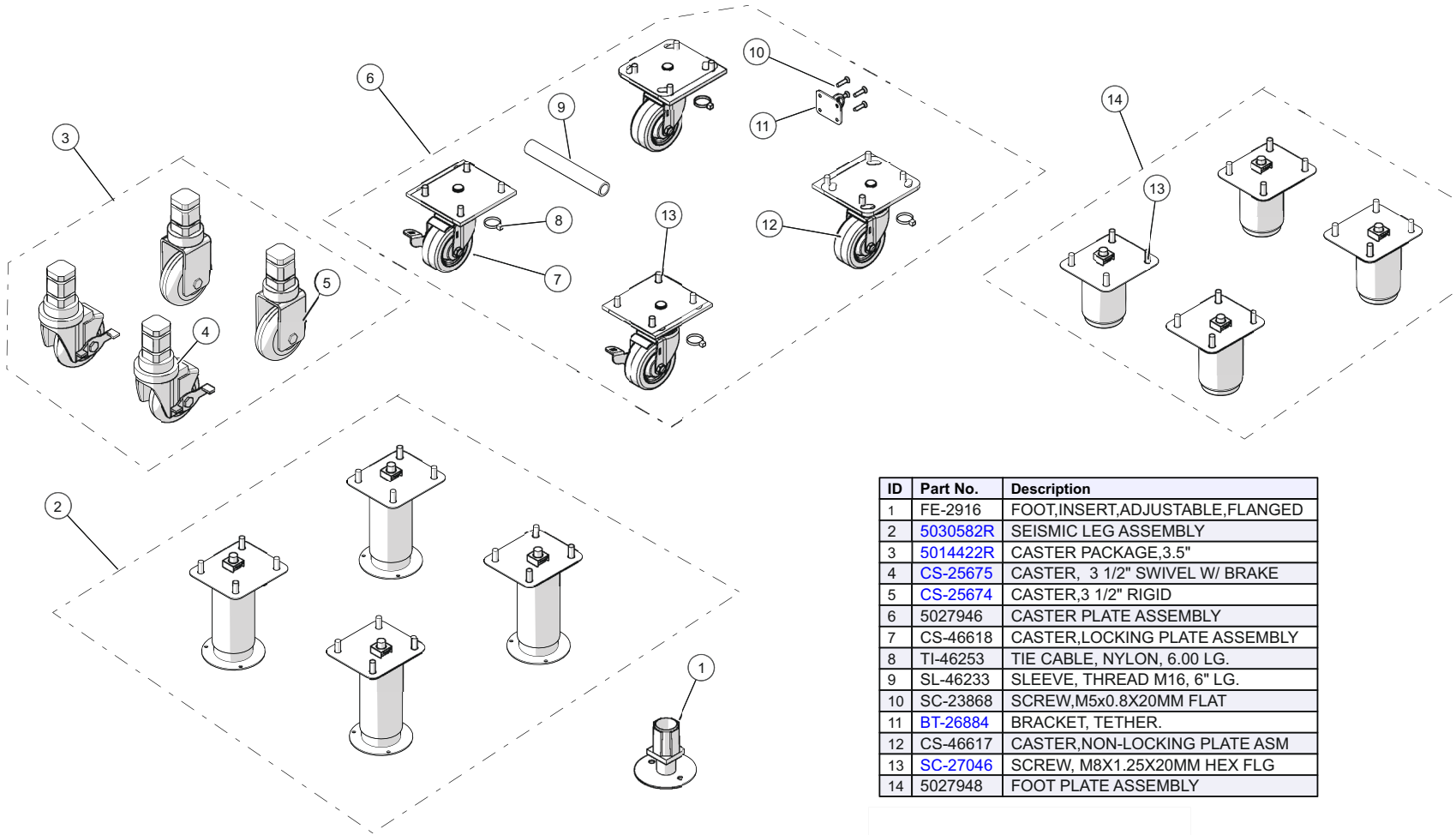

ID	Part No.	Description
1	FE-2916	FOOT,INSERT,ADJUSTABLE,FLANGED
2	5030582R	SEISMIC LEG ASSEMBLY
3	5014422R	CASTER PACKAGE,3.5"
4	CS-25675	CASTER, 3 1/2" SWIVEL W/ BRAKE
5	CS-25674	CASTER,3 1/2" RIGID
6	5027946	CASTER PLATE ASSEMBLY
7	CS-46618	CASTER,LOCKING PLATE ASSEMBLY
8	TI-46253	TIE CABLE, NYLON, 6.00 LG.
9	SL-46233	SLEEVE, THREAD M16, 6" LG.
10	SC-23868	SCREW,M5x0.8X20MM FLAT
11	BT-26884	BRACKET, TETHER.
12	CS-46617	CASTER,NON-LOCKING PLATE ASM
13	SC-27046	SCREW, M8X1.25X20MM HEX FLG
14	5027948	FOOT PLATE ASSEMBLY

Casters and Feet: Where Used

		CS-26575	CS-25674	5027946R	BT-26884	FE-2916
		Caster, 3-1/2" with 1-1/2" stem, swivel	Caster, 3-1/2" with 1-1/2" stem, rigid	Caster Plate Assembly	Bracket, Tether Restraint	Foot, Insert, Adjustable, Flanged
5028173	Stand, 24" Vector H/HXH with Casters	2	2			
5027644	Stand, 36" Vector H/HXH			NONE		
5027834	Stand, Stacking, Vector H3/H3H over H3/H3H			NONE		
5027835	Stand, Stacking, Vector H4/H4H over H3/H3H			NONE		
5028223	Stand, 24" Vector HX/HXH with Feet					4
5027762	Kit, Stand, Vector HX/HXH over C&H 750 Series, w/Feet					4
5028895	Stand, 24" Vector HX/HXH with Casters, Special Spacing	2	2			
5031561	Stand, Vector over TC	2	2			
5030611	Stand, 34", Vector HX/HXH over 750-TH3, with feet					4
5032360	Stand, 34", Vector HX/HXH over 750-TH3, with casters	2	2			
5030180	Kit, Stand, VH2/H	4				
5030178	Kit, Stand, Stacking, over VH3			1	1	
5030179	Kit, Stand, Stacking, over VH4			1	1	



ALTO-SHAAM.

Menomonee Falls, WI U.S.A.

Phone 800-558-8744 | +1-262-251-3800 | alto-shaam.com

ASIA

Shanghai, China
Phone +86-21-6173-0336

AUSTRALIA

Brisbane, Queensland
Phone 800-558-8744

CANADA

Concord, Ontario Canada
Toll Free Phone 866-577-4484
Phone +1-905-660-6781

FRANCE

Aix en Provence, France
Phone +33(0)4-88-78-21-73

GMBH

Bochum, Germany
Phone +49 (0)234 298798-0

ITALY

Padua, Italy
Phone +39 3476073504

INDIA

Pune, India
Phone +91 9657516999

MEXICO

Phone +52 1 477-717-3108

MIDDLE EAST & AFRICA

Dubai, UAE
Phone +971-4-321-9712

CENTRAL & SOUTH AMERICA

Miami, FL USA
Phone +1 954-655-5727

RUSSIA

Moscow, Russia
Phone +7 903 7932331