

# ALTO-SHAAM®

## Cook & Hold Oven Touch Control



**Model:  
300-TH/III Touch**

- **INSTALLATION**
- **OPERATION**
- **MAINTENANCE**

W164 N9221 Water Street • P.O. Box 450  
Menomonee Falls, Wisconsin 53052-0450 U.S.A.

PHONE: 262.251.3800 • 800.558.8744 U.S.A. / CANADA  
FAX: 262.251.7067 • 800.329.8744 U.S.A. ONLY  
[www.alto-shaam.com](http://www.alto-shaam.com)



Consult instructions  
for operation and use.





Delivery ..... 1  
Unpacking ..... 1  
Safety Procedures and Precautions .....2-3

**Installation**

Installation Requirements ..... 4  
Clearance Requirements ..... 4  
Dimension Drawings, weights & capacities ..... 5  
Electrical Specifications ..... 5  
Site Installation ..... 6  
Leveling ..... 6  
User Safety Information..... 6  
Electrical Connection ..... 7

**Operating Instructions**

Operating Instructions.....8-13  
Audible Signals ..... 13  
General Holding Guidelines..... 14

**Care and Cleaning**

Protecting Stainless Steel Surfaces..... 15  
Cleaning Agents ..... 15  
Cleaning Materials ..... 15  
Equipment Care ..... 16  
Daily Cleaning ..... 16  
Cleaning the Probes ..... 16  
Check Overall Condition of Oven ..... 16

**Sanitation**

Sanitation/Food Safety ..... 17  
Internal Food Product Temperatures..... 17

**Service**

Trouble Shooting..... 18  
Trouble Shooting - Error Codes..... 19  
Service Views & Parts  
- Full View .....20-21  
- Front View..... 22  
- Top View ..... 23

**Wire Diagrams**

Always refer to the wire diagram(s) included with the unit for most current version.

**Warranty**

Transportation Damage and Claims ..... Back Cover  
Limited Warranty..... Back Cover



## DELIVERY

This Alto-Shaam appliance has been thoroughly tested and inspected to ensure only the highest quality unit is provided. Upon receipt, check for any possible shipping damage and report it at once to the delivering carrier. *See Transportation Damage and Claims section located in this manual.*

This appliance, complete with unattached items and accessories, may have been delivered in one or more packages. Check to ensure that all standard items and options have been received with each model as ordered.

Save all the information and instructions packed with the appliance. Register online at [www.alto-shaam.com](http://www.alto-shaam.com) or complete and return the warranty card to the factory as soon as possible to ensure prompt service in the event of a warranty parts and labor claim.

This manual must be read and understood by all people using or installing the equipment model. Contact the Alto-Shaam Tech Team Service Department if you have any questions concerning installation, operation, or maintenance.

**NOTICE:** All claims for warranty must include the full model number and serial number of the appliance.

## WARNING



Appliance and accessories may be heavy. To prevent serious injury, ALWAYS use a sufficient number of trained and experienced workers when moving or leveling appliance and handling accessories.

## ENVIRONMENTAL CONDITIONS

- Operational Environmental Conditions
- Unit must acclimate to room temperature in the environment it is placed. 24 hours is recommended.
- Ambient temperature range of 50° to 110°F (10° to 43°C).
- Relative humidity of less than 95% non-condensation.
- Atmospheric pressure range of 50KPa to 106KPa.

## UNPACKING

- Carefully remove the appliance from the carton or crate.

**NOTICE:** Do not discard the carton and other packaging material until you have inspected the unit for hidden damage and tested it for proper operation.

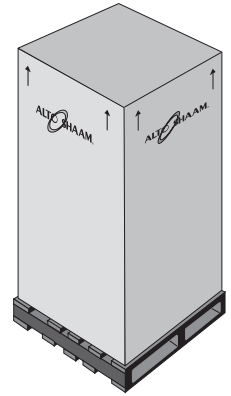

- Read all instructions in this manual carefully before initiating the installation of this appliance, using the appliance or performing routine maintenance. Following procedures other than those indicated in this guide to use and clean the appliance is considered inappropriate and may cause damage, injury or fatal accidents, in addition to invalidating the guarantee and relieving Alto-Shaam of all liability.
- DO NOT DISCARD THIS MANUAL. This manual is considered to be part of the appliance and is to be provided to the owner or manager of the business or to the person responsible for training operators. *Additional manuals are available from the Alto-Shaam Tech Team Service Department.*
- Remove all protective plastic film, packaging materials, and accessories from the appliance before connecting electrical power. Store any accessories in a convenient place for future use.

## SAFETY PROCEDURES AND PRECAUTIONS

Knowledge of proper procedures is essential to the safe operation of electrically and/or gas energized equipment. In accordance with generally accepted product safety labeling guidelines for potential hazards, the following signal words and symbols may be used throughout this manual.

### DANGER



Used to indicate the presence of a hazard that **WILL** cause severe personal injury, death, or substantial property damage if the warning included with this symbol is ignored.

### WARNING



Used to indicate the presence of a hazard that **CAN** cause personal injury, possible death, or major property damage if the warning included with this symbol is ignored.

### CAUTION



Used to indicate the presence of a hazard that can or will cause minor or moderate personal injury or property damage if the warning included with this symbol is ignored.

### CAUTION

Used to indicate the presence of a hazard that can or will cause minor personal injury, property damage, or a potential unsafe practice if the warning included with this symbol is ignored.

**NOTICE:** Used to notify personnel of installation, operation, or maintenance information that is important but not hazard related.



Used to indicate that referral to operating instructions is a mandatory action. If not followed the operator could suffer personal injury.



Used to indicate that referral to operating instructions is recommended to understand operation of equipment.

- This appliance is intended to cook, hold or process foods for the purpose of human consumption. No other use for this appliance is authorized and is therefore considered dangerous. The appliance must not be used to cook food containing flammable materials (such as food with alcohol). Substances with a low flash point can ignite spontaneously and cause a fire.
- This appliance is intended for use in commercial establishments where all operators are familiar with the purpose, limitations, and associated hazards of this appliance. Operating instructions and warnings must be read and understood by all operators and users. We recommend regular training of your staff to avoid the risk of accident or damage to the unit. Operators must also receive regular safety instructions.
- Any troubleshooting guides, component views, and parts lists included in this manual are for general reference only and are intended for use by qualified and trained technicians.
- This manual should be considered a permanent part of this appliance. This manual and all supplied instructions, diagrams, schematics, parts lists, notices, and labels must remain with the appliance if the item is sold or moved to another location.

### NOTICE

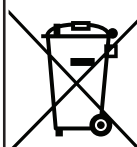

For equipment delivered for use in any location regulated by the following directive:

**DO NOT** dispose of electrical or electronic equipment with other municipal waste.

## ADDITIONAL SAFETY PROCEDURES AND PRECAUTIONS

- To prevent serious injury, death or property damage, your appliance should be inspected and serviced at least every twelve (12) months by an authorized service partner or trained technician.
- ONLY allow an authorized service partner or trained technician to service or to repair your appliance. Installation or repairs that are not performed by an authorized service partner or trained technician, or the use of non-factory authorized parts will void the warranty and relieve Alto-Shaam of all liability.
- When working on this appliance, observe precautions in the literature, on tags, on labels attached to or shipped with the appliance and other safety precautions that may apply.
- If the appliance is installed on casters freedom of movement of the appliance must be restricted so that utility connections (including gas, water, and electricity) cannot be damaged when the unit is moved. If the appliance is moved, make sure that all utility connections are properly disconnected. If the unit is returned to its original position, make sure that any retention devices and utility connections are properly connected.
- ONLY use the appliance when it is stationary. Mobile oven racks, mobile plate racks, transport trolleys, and appliances on casters can tip over when being moved over an uneven floor or threshold and cause serious injury.
- ALWAYS apply caster brakes on mobile appliances or accessories when these are not being moved. These items could move or roll on uneven floors and cause property damage or serious injury.
- Be extremely careful when moving appliances because the food trays may contain hot fluids that may spill, causing serious injury.
- ALWAYS open the appliance door very slowly. Escaping hot vapors or steam can cause serious injury or death.

### WARNING



To prevent **SERIOUS INJURY, DEATH, or PROPERTY DAMAGE:**

The appliance must be cleaned thoroughly to avoid deposits of grease and or food residues inside the appliance that may catch fire. If fat deposits and/or food waste inside the appliance ignite, shut down the appliance immediately and keep the appliance door closed to extinguish the fire. If further extinguishing is required, disconnect the appliance from the main power and use a fire extinguisher (do not use water to extinguish a grease fire!). Failure to clean the appliance properly invalidates the warranty and relieves Alto-Shaam of all liability.

### WARNING



This appliance is not intended for use by persons (including children) with reduced physical, sensory or mental capabilities, or lack of experience and knowledge, unless they have been given supervision concerning use of the appliance by person responsible for their safety.

Children should be supervised to ensure that they do not play with the appliance.

# INSTALLATION

## WARNING



Improper installation, alteration, adjustment, service, cleaning, or maintenance could result in property damage, severe injury, or death.

**READ** and **UNDERSTAND** the installation, operating and maintenance instructions thoroughly before installing, servicing, or operating this equipment.

## WARNING



Appliance and accessories may be heavy. To prevent serious injury, **ALWAYS** use a sufficient number of trained and experienced workers when moving or leveling appliance and handling accessories.

## CAUTION



To prevent **SEVERE PERSONAL INJURY** or **PROPERTY DAMAGE**:

**ALWAYS** use hand protection when operating this appliance to avoid burns. Metal parts of this equipment become extremely hot when in operation.

## WARNING



**FOR YOUR SAFETY**

**DO NOT** store or use gasoline or other flammable vapors or liquids in the vicinity of this or any other appliance.

# SITE INSTALLATION

The Alto-Shaam cook and hold oven must be installed in a location that will permit the oven to function for its intended purpose and to allow adequate clearance for ventilation, proper cleaning, and maintenance access.

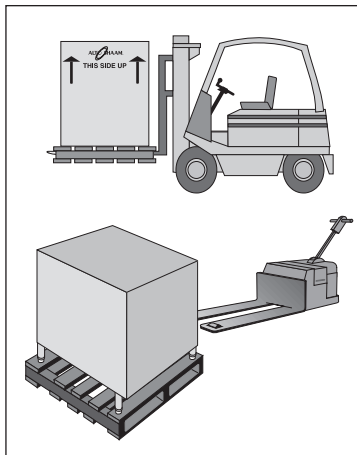

1. The oven must be installed on a stable and level surface.
2. **DO NOT** install this appliance in any area where it may be affected by any adverse conditions such as steam, grease, dripping water, high temperatures, or any other severely adverse conditions.
3. **DO NOT** store or use any flammable liquids or allow flammable vapors in the vicinity of this oven or any other appliance.
4. This appliance must be kept free and clear of any combustible materials.
5. This appliance must be kept free and clear of any obstructions blocking access for maintenance or service.

Emissions testing conducted by Underwriters Laboratories, Inc.® was found to be in compliance with the applicable requirements of NFPA96: 2004 Edition, Par. 4.1.1.2. U.L emissions sampling of grease laden vapor resulted in a total of 0.55 milligrams per cubic meter with no visible smoke and is considered representative of all oven models in the line. Based on these results, hood installation and/or outside venting should not be a requirement in most areas. Verify local codes for locations where more restrictive codes are applicable.

### **NOTICE:**

Due to normal vibration, or temperature variations encountered during shipping, it may be necessary to reset the hi-limit switch at the back of the oven before use.

### **CLEARANCE REQUIREMENTS**

18" (457mm) minimum clearance at the back from heat producing equipment. To protect the electronic control, maintain sufficient side clearance to prevent the control area from reaching any temperature at or above 140°F (60°C).

# INSTALLATION

## SITE INSTALLATION

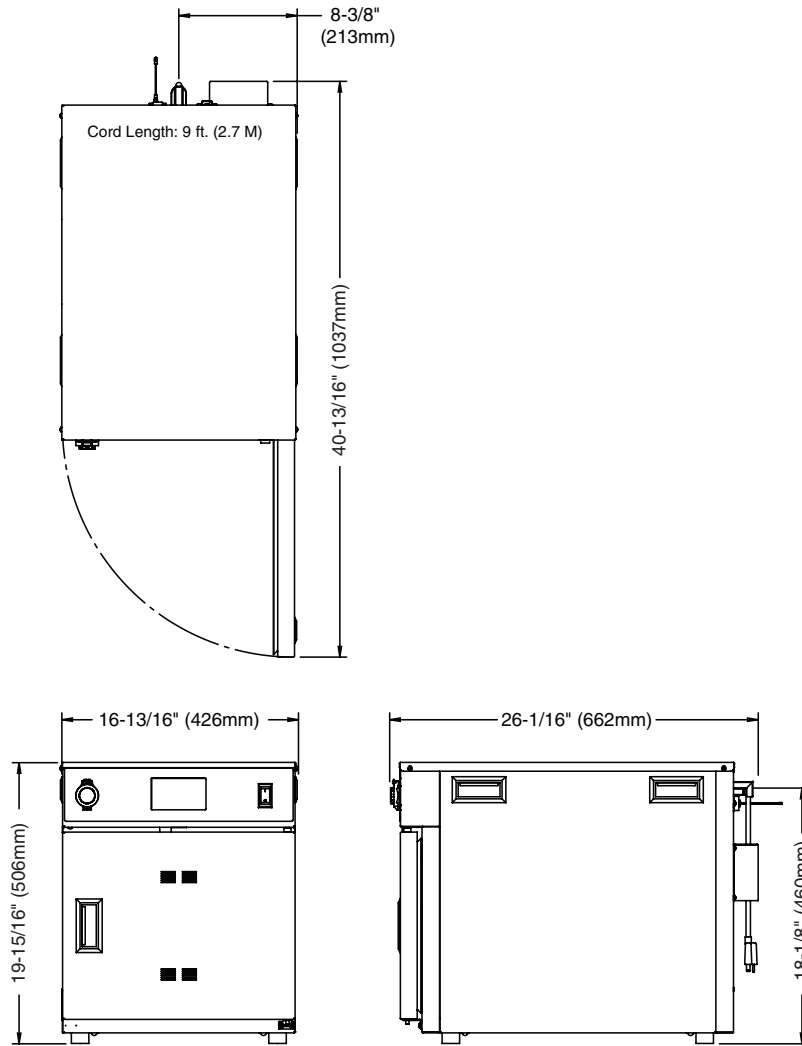

<b>DIMENSIONS:</b> H x W x D		<b>ELECTRICAL</b>						
<b>OVEN EXTERIOR:</b>	19-15/16" x 16-13/16" x 26-1/16" (506mm x 426mm x 662mm)	<b>VOLTAGE</b>	<b>PHASE</b>	<b>CYCLE/HZ</b>	<b>AMPS</b>	<b>kW</b>	<b>CORD &amp; PLUG</b>	
<b>OVEN INTERIOR:</b>	12-1/2" x 13-5/8" x 21-1/2" (318mm x 346mm x 546mm)	120	1	60	6.7	.80	NEMA 5-15P 15A-125V PLUG	
<b>CLEARANCE REQUIREMENTS</b>		<b>INSTALLATION REQUIREMENTS</b>						
18" (457mm) minimum clearance at the back from heat producing equipment. To protect the electronic control, maintain sufficient side clearance to prevent the control area from reaching any temperature at or above 140°F (60°C).		— Oven must be installed level. — The oven must not be installed in any area where it may be affected by steam, grease, dripping water, extreme temperatures, or any other severely adverse conditions.						
<b>CAPACITY</b>		<b>WEIGHT</b>						
44 lbs (20 kg) MAXIMUM		NET: 69 lbs (31 kg)				SHIP: 129 lbs (59 kg)		
		CARTON DIMENSIONS: (L x W x H) 36" x 24" x 28" (914mm x 610mm x 711mm)						

# INSTALLATION

## SITE INSTALLATION

A number of adjustments are associated with initial installation and start-up. It is important that these adjustments be conducted by a qualified service technician. Installation and start-up adjustments are the responsibility of the dealer or user. These adjustments include but are not limited to thermostat calibration, door adjustment, leveling, electrical hook-up and installation of optional casters or legs.

## LEVELING

Level the oven from side-to-side and front-to-back with the use of a spirit level. For ovens installed with casters, it is important that the installation surface be level due to the probability of frequent oven repositioning.

We recommend checking the level of the oven periodically to make certain the floor has not shifted nor the oven moved.

**NOTE:** Failure to properly level this oven can cause improper function and will result in the uneven baking with products consisting of semi-liquid batter.

**WARNING**

**RISK OF ELECTRIC SHOCK.**



Appliance must be secured to building structure. Failure to observe this precaution may result in damage to the equipment and severe personal injury.

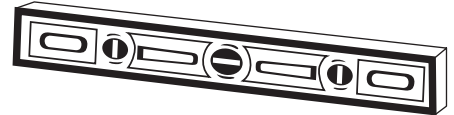

## USER SAFETY INFORMATION

The Alto-Shaam cook and hold oven is intended for use in commercial establishments by qualified operating personnel where all operators are familiar with the purpose, limitations, and associated hazards of this appliance. Operating instructions and warnings must be read and understood by all operators and users.

**CAUTION**



To prevent **SEVERE PERSONAL INJURY** or **PROPERTY DAMAGE**:

**ALWAYS** use hand protection when operating this appliance to avoid burns. Metal parts of this equipment become extremely hot when in operation.

**WARNING**



To prevent **SERIOUS INJURY, DEATH, OR PROPERTY DAMAGE**, **ALWAYS** disconnect unit from power source before cleaning or servicing.

**DANGER**



To prevent **SERIOUS PERSONAL INJURY, DEATH, or PROPERTY DAMAGE**:

**DO NOT** steam clean, hose down or flood the interior or exterior with water or liquid solution of any kind. **DO NOT** use water jet to clean.

Failure to observe this precaution will void the warranty.

# INSTALLATION

## ELECTRICAL CONNECTION

The appliance must be installed by a qualified service technician. The oven must be properly grounded in accordance with the National Electrical Code and applicable local codes.

Plug the unit into a properly grounded receptacle ONLY, positioning the unit so that the plug is easily accessible in case of an emergency. Arcing will occur when connecting or disconnecting the unit unless all controls are in the "OFF" position.

Proper receptacle or outlet configuration or permanent wiring for this unit must be installed by a licensed electrician in accordance with applicable local electrical codes.

### REGARDING INTERNATIONAL STANDARD UNITS:

If the unit is not equipped with flexible cord and plug, an all-pole country approved disconnection device which has a contact separation of at least 3mm in all poles must be incorporated in the fixed wiring for disconnection. When using a cord without a plug, the green/yellow conductor shall be connected to the terminal which is marked with the ground symbol. If a plug is used, the socket outlet must be easily accessible. If the power cord needs replacement, use a similar one obtained from the distributor.



**For CE approved units:** To prevent an electrical shock hazard between the appliance and other appliances or metal parts in close vicinity, an equalization-bonding stud is provided. An equalization bonding lead must be connected to this stud and the other appliances/metal parts to provide sufficient protection against potential difference. The terminal is marked with the following symbol.



### Hard wired models:

Hard wired models must be equipped with a country certified external allpole disconnection switch with sufficient contact separation.

If a power cord is used for the connection of the product an oil resistant cord like H05RN or H07RN or equivalent must be used.

**NOTICE:** Where local codes and CE regulatory requirements apply, appliances must be connected to an electrical circuit that is protected by an external GFCI outlet.

## WARNING



To prevent **SERIOUS INJURY, DEATH, or PROPERTY DAMAGE:**

All electrical connections must be made by a qualified and trained service technician in accordance with applicable electrical codes.



This appliance **MUST** be adequately grounded in accordance with local electrical codes or, in the absence of local codes, with the current edition of the National Electrical Code ANSI/NFPA No. 70. In Canada, all electrical connections are to be made in accordance with CSA C22.1, Canadian Electrical Code Part 1 or local codes.

## ⚠ DANGER



Ensure power source matches voltage identified on appliance rating tag. The rating tag provides essential technical information required for any appliance installation, maintenance or repairs. Do not remove, damage or modify the rating tag.

## DANGER



Appliances with no cord provided by factory must be equipped with a cord of sufficient length to permit the appliance to be moved for cleaning.



To prevent **SERIOUS INJURY, DEATH, or PROPERTY DAMAGE:** All electrical connections must be made by a qualified service technician in accordance with applicable electrical codes.

**ALWAYS** use the correct AWG wire size based on the electrical requirements for the appliance.

# OPERATION

## OPERATING INSTRUCTIONS

### TOUCH SCREEN MENUS

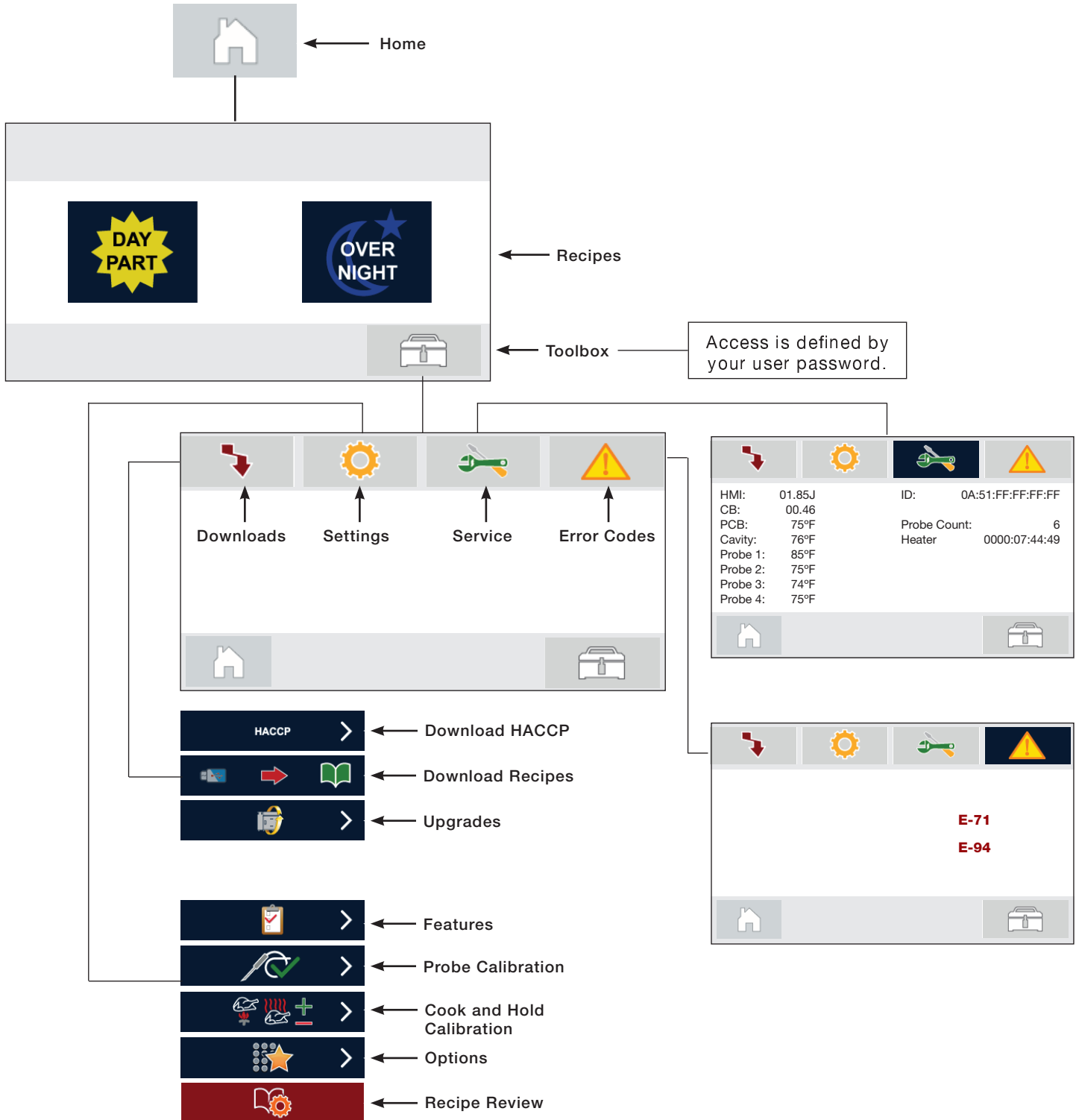





# OPERATION

## OPERATING INSTRUCTIONS

Turn on the power switch located on the front of the oven. Home screen will appear.

Select desired Recipe.



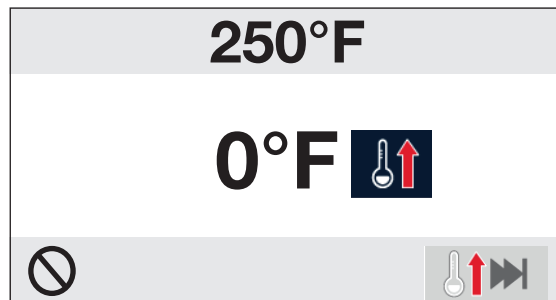

The following screen will display and  will flash until oven reaches the selected Recipe preheat temperature. Once preheat temperature is reached,  will illuminate. Press  to advance to the probe count screen. Press  at any time to cancel the preheat cycle and return to the home screen.



Select the number of probes in use (1-4). **Note:** Probe 5 and 6 are non-applicable on this unit. Beef Code entry screen will display.

Use numeric key pad to enter the Beef Code for each probe (00/00/00:000/00).

Pressing  will use the last entered value. Pressing  will go back to the previous probe setting.

Once all probe Beef Codes have been entered, press  to accept the settings. Cook mode will start and screen will return to the Cook screen.

# OPERATION

## OPERATING INSTRUCTIONS



### Downloads

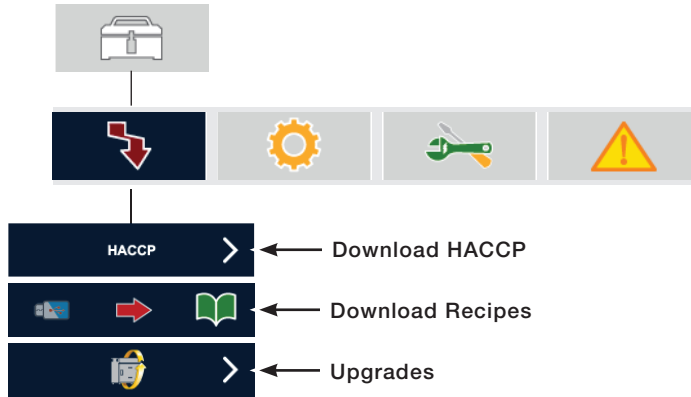

(ACCESSIBLE BY PASSWORD ONLY)



### Download HACCP

1. Insert USB data stick into data port on front of the unit.
2. Touch  and then . Screen will show the HACCP file that is being copied and will display any errors that occur while the file is downloading. When "Done" is displayed, transfer is complete. Pull the data stick out of the data port. **Note:** If USB is not found when download icon is touched a "Failed to detect USB" message will display on the screen.

All data has been transferred to the USB stick and is erased from the control. A folder called "haccp" is created on the USB data stick containing dated excel file names for each mode since the last HACCP download. A new file will be created each time a new mode is started. **Note:** HACCP cannot be downloaded when unit is cooking or holding.

**Note:** HACCP data is retained for 30 days.

### Sample of Data File

Serial Number: 0A:51:FF:FF:FF:FF  
 IB Version: 01.85J  
 CB Version: 0.46  
 Start Time: 2014/10/31 11:41:58  
 Cavity: SINGLE  
 Program Name: OVER NIGHT  
 Probe1 ID: 58/38/68:868/80  
 Probe2 ID: 74/56/95:550/00  
 Probe3 ID: 58/52/46:855/00  
 Probe4 ID: 58/52/46:855/00

**HACCP data can only be read using Alto-Shaam HACCP Viewer software.**



Date	Time	Mode	Step	Cavity Set	Time Set	Probe Set	Cavity Actual (°F)	Probe1 Actual (°F)	Probe2 Actual (°F)	Probe3 Actual (°F)	Probe4 Actual (°F)	Door
10/31/14	11:41:58	PREHEAT	1	210	0:45:00		256	270	261	262	262	0
10/31/14	11:41:58	COOK	2	210		50	256	270	261	262	262	0
10/31/14	11:42:00	COOK	2	210		50	255	269	260	261	262	0
10/31/14	11:42:18	HOLD	3	150		135	255	270	260	261	262	0
10/31/14	11:43:00	HOLD	3	150		135	253	269	259	260	261	0
10/31/14	11:44:00	HOLD	3	150		135	252	269	259	259	261	0
10/31/14	11:45:00	HOLD	3	150		135	249	268	257	257	259	0
10/31/14	11:46:00	HOLD	3	150		135	247	267	256	256	259	0
10/31/14	11:47:00	HOLD	3	150		135	245	266	254	254	257	0
10/31/14	11:48:00	HOLD	3	150		135	243	265	253	253	256	0
10/31/14	11:49:00	HOLD	3	150		135	241	263	251	251	255	0
10/31/14	11:50:00	HOLD	3	150		135	239	262	249	249	253	0
10/31/14	11:51:00	HOLD	3	150		135	237	260	248	247	251	0
10/31/14	11:52:00	HOLD	3	150		135	235	258	247	246	249	0
10/31/14	11:53:00	HOLD	3	150		135	233	257	245	244	248	0

# OPERATION

## OPERATING INSTRUCTIONS



### Downloads (CONTINUED)

#### Download Recipes

1. Insert USB data stick into data port on front of the unit.
2. Touch  and then .
3. Display will indicate that a download is in process. When complete, pull the data stick out of the data port. Screen will return to Home screen.

**Note:** Download cannot be done when oven is cooking or holding.

#### Upgrades (cannot be done when oven is cooking or holding)

1. Insert USB data stick into data port on front of the unit.
2. Touch  and then .
3. Choose one of the following:

 - Upgrade All

 - Upgrade Interface Board (Touch Screen)

 - Upgrade Control Board

Display will indicate that an upgrade is in process. When complete, pull the data stick out of the data port. Screen will return to Home screen.

**Once the upgrade is complete, you must reset the control to the Factory Presets by selecting the following:**

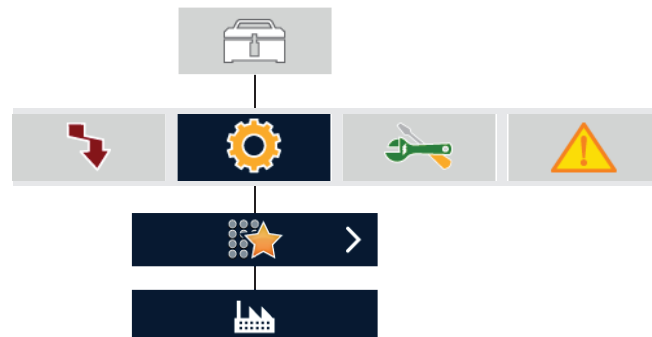

# OPERATION

## OPERATING INSTRUCTIONS

### Settings



(ALL BUT FEATURES IS ACCESSIBLE BY PASSWORD ONLY)

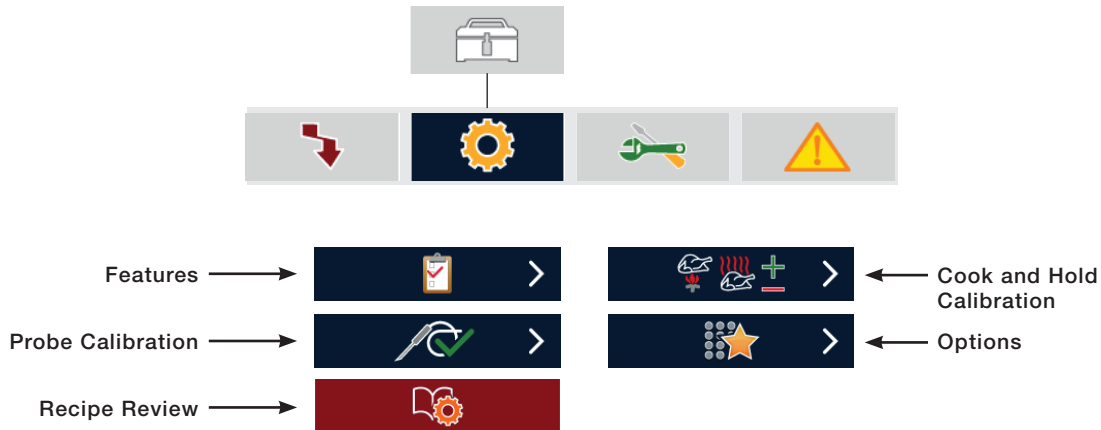

### Features

Touch to toggle between Celsius and Fahrenheit.

Touch to turn sound On or Off.

### Probe Calibration

Select number of probe you wish to calibrate (1-4). **Note:** Probe 5 and 6 are non-applicable on this unit.

Use or to adjust calibration.

### Recipe Review

Used to review temperature and time settings.

### Cook and Hold Calibration

Select to calibrate Cook mode, or of probe to calibrate Hold mode.

Use or to adjust calibration.

### Options

Touch to set date and time. Use or to set MM/DD/YY, HH:MM.

Touch to set number of probes in use (1-4). **Note:** Probe 5 and 6 are non-applicable on this unit.

Touch to calibrate touch screen. Follow instructions on screen to calibrate.

Touch to reset all presets and user-defined settings to factory default settings.

**Warning:** Pressing Factory Reset will erase all User Settings, Recipes and presets programmed by the user. **Note:** Factory Settings cannot be reset when oven is cooking or holding.

# OPERATION

## OPERATING INSTRUCTIONS

### Service

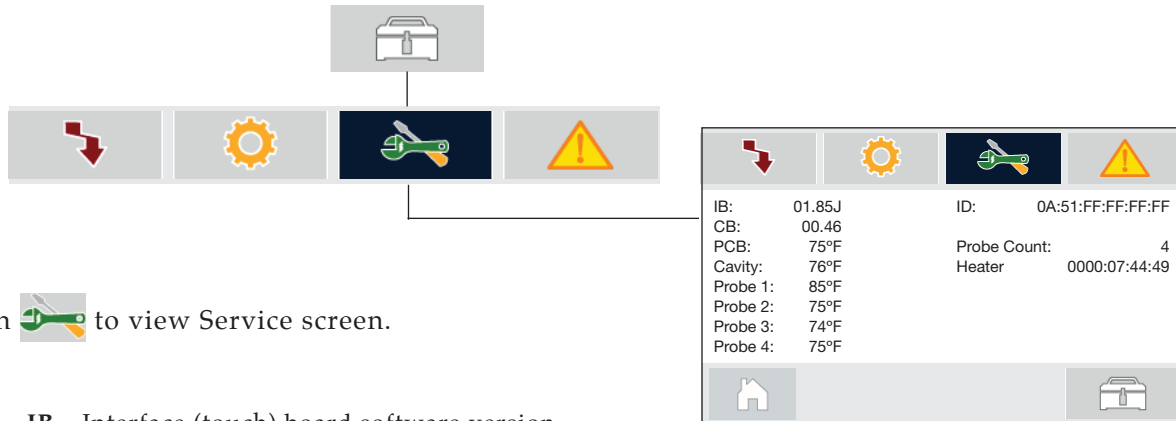

Touch  to view Service screen.

**IB** – Interface (touch) board software version

**CB** – Control board software version

**PCB** – Temperature of control board

**Cavity** – Cavity Temperature

**Probe 1-4** – Internal temperature of food product

**ID** – Unique identifier (tied to CB). Uniquely identifies the unit.

**Heater** – White = OFF, Green = ON. 0000:00:00:00 is lifetime run of the heating element, in days:hours:minutes:seconds

### Error Codes

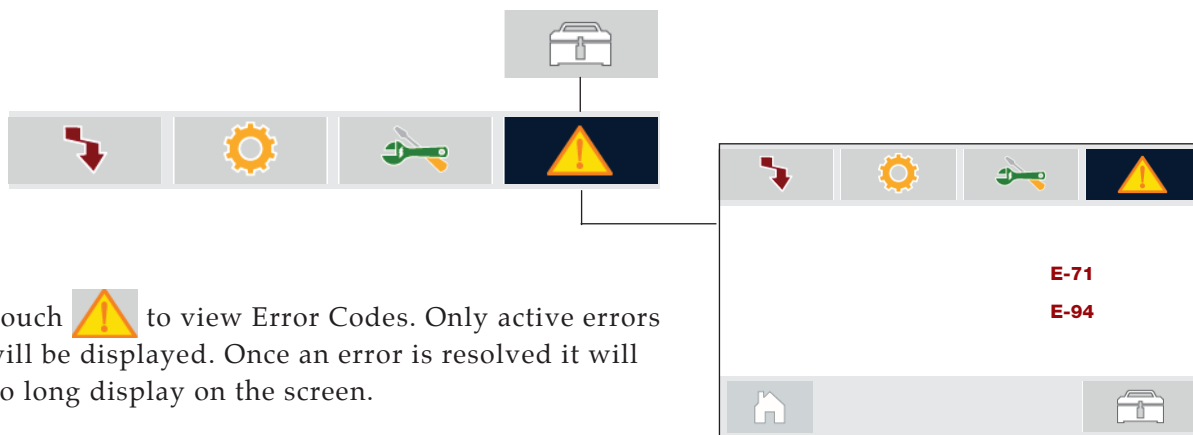

Touch  to view Error Codes. Only active errors will be displayed. Once an error is resolved it will no longer display on the screen.

### Audible Signals



*One brief beep* - response to a key being pressed.

*Long beep* - oven is changing modes, i.e. from cook to hold.

*Continuous beeps at 1 second intervals* - indicates oven has reached preheat temperature.

# OPERATION

## GENERAL HOLDING GUIDELINES

Chefs, cooks and other specialized food service personnel employ varied methods of cooking. Proper holding temperatures for a specific food product must be based on the moisture content of the product, product density, volume, and proper serving temperatures. Safe holding temperatures must also be correlated with palatability in determining the length of holding time for a specific product.

Halo Heat maintains the maximum amount of product moisture content without the addition of water, water vapor, or steam. Maintaining maximum natural product moisture preserves the natural flavor of the product and provides a more genuine taste. In addition to product moisture retention, the gentle properties of Halo Heat maintain a consistent temperature throughout the cabinet without the necessity of a heat distribution fan, thereby preventing further moisture loss due to evaporation or dehydration.

When product is removed from a high temperature cooking environment for immediate transfer into equipment with the lower temperature required for hot food holding, condensation can form on the outside of the product and on the inside of plastic containers used in self-service applications. Allowing the product to release the initial steam and heat produced by high temperature cooking can alleviate this condition. To preserve the safety and quality of freshly cooked foods, however, a maximum of 1 to 2 minutes must be the only time period allowed for the initial heat to be released from the product.

Most Halo Heat Holding Equipment is provided with a thermostat control between 60° and 200°F (16° to 93°C). If the unit is equipped with vents, close the vents for moist holding and open the vents for crisp holding.

HOLDING TEMPERATURE RANGE		
MEAT	FAHRENHEIT	CELSIUS
BEEF ROAST — Rare	130°F	54°C
BEEF ROAST — Med/Well Done	155°F	68°C
BEEF BRISKET	160°F — 175°F	71°C — 79°C
CORN BEEF	160°F — 175°F	71°C — 79°C
PASTRAMI	160°F — 175°F	71°C — 79°C
PRIME RIB — Rare	130°F	54°C
STEAKS — Broiled/Fried	140°F — 160°F	60°C — 71°C
RIBS — Beef or Pork	160°F	71°C
VEAL	160°F — 175°F	71°C — 79°C
HAM	160°F — 175°F	71°C — 79°C
PORK	160°F — 175°F	71°C — 79°C
LAMB	160°F — 175°F	71°C — 79°C
POULTRY		
CHICKEN — Fried/Baked	160°F — 175°F	71°C — 79°C
DUCK	160°F — 175°F	71°C — 79°C
TURKEY	160°F — 175°F	71°C — 79°C
GENERAL	160°F — 175°F	71°C — 79°C
FISH/SEAFOOD		
FISH — Baked/Fried	160°F — 175°F	71°C — 79°C
LOBSTER	160°F — 175°F	71°C — 79°C
SHRIMP — Fried	160°F — 175°F	71°C — 79°C
BAKED GOODS		
BREADS/ROLLS	120°F — 140°F	49°C — 60°C
MISCELLANEOUS		
CASSEROLES	160°F — 175°F	71°C — 79°C
DOUGH — Proofing	80°F — 100°F	27°C — 38°C
EGGS — Fried	150°F — 160°F	66°C — 71°C
FROZEN ENTREES	160°F — 175°F	71°C — 79°C
HORS D'OEUVRES	160°F — 180°F	71°C — 82°C
PASTA	160°F — 180°F	71°C — 82°C
PIZZA	160°F — 180°F	71°C — 82°C
POTATOES	180°F	82°C
PLATED MEALS	140°F — 165°F	60°C — 74°C
SAUCES	140°F — 200°F	60°C — 93°C
SOUP	140°F — 200°F	60°C — 93°C
VEGETABLES	160°F — 175°F	71°C — 79°C
<b>THE HOLDING TEMPERATURES LISTED ARE SUGGESTED GUIDELINES ONLY. ALL FOOD HOLDING SHOULD BE BASED ON INTERNAL PRODUCT TEMPERATURES. ALWAYS FOLLOW LOCAL HEALTH (HYGIENE) REGULATIONS FOR ALL INTERNAL TEMPERATURE REQUIREMENTS.</b>		

# CARE AND CLEANING

## PROTECTING STAINLESS STEEL SURFACES



It is important to guard against corrosion in the care of stainless steel surfaces. Harsh, corrosive, or inappropriate chemicals can completely destroy the protective surface layer of stainless steel. Abrasive pads, steel wool, or metal implements will abrade surfaces causing damage to this protective coating and will eventually result in areas of corrosion. Even water, particularly hard water that contains high to moderate concentrations of chloride, will cause oxidation and pitting that result in rust and corrosion. In addition, many acidic foods spilled and left to remain on metal surfaces are contributing factors that will corrode surfaces.

Proper cleaning agents, materials, and methods are vital to maintaining the appearance and life of this appliance. Spilled foods should be removed and the area wiped as soon as possible but at the very least, a minimum of once a day. Always thoroughly rinse surfaces after using a cleaning agent and wipe standing water as quickly as possible after rinsing.

## CAUTION



To protect stainless steel surfaces, completely avoid the use of abrasive cleaning compounds, chloride based cleaners, or cleaners containing quaternary salts. **NEVER** use hydrochloric acid (muriatic acid) on stainless steel. **NEVER** use wire brushes, metal scouring pads or scrapers.

## CLEANING AGENTS

Use non-abrasive cleaning products designed for use on stainless steel surfaces. Cleaning agents must be chloride-free compounds and must not contain quaternary salts. Never use hydrochloric acid (muriatic acid) on stainless steel surfaces. Always use the proper cleaning agent at the manufacturer's recommended strength. Contact your local cleaning supplier for product recommendations.

## CLEANING MATERIALS

The cleaning function can usually be accomplished with the proper cleaning agent and a soft, clean cloth. When more aggressive methods must be employed, use a non-abrasive scouring pad on difficult areas and make certain to scrub with the visible grain of surface metal to avoid surface scratches. Never use wire brushes, metal scouring pads, or scrapers to remove food residue.

## WARNING



To prevent **SERIOUS INJURY, DEATH, or PROPERTY DAMAGE:**

The appliance must be cleaned thoroughly to avoid deposits of grease and or food residues inside the appliance that may catch fire. If fat deposits and/or food waste inside the appliance ignite, shut down the appliance immediately and keep the appliance door closed to extinguish the fire. If further extinguishing is required, disconnect the appliance from the main power and use a fire extinguisher (do not use water to extinguish a grease fire!). Failure to clean the appliance properly invalidates the warranty and relieves Alto-Shaam of all liability.

# CARE AND CLEANING

## EQUIPMENT CARE

Under normal circumstances, this oven should provide you with long and trouble free service. There is no preventative maintenance required, however, the following Equipment Care Guide will maximize the potential life and trouble free operation of this oven.



The cleanliness and appearance of this equipment will contribute considerably to operating efficiency and savory, appetizing food. Good equipment that is kept clean works better and lasts longer.

## CLEAN OVEN DAILY

1. Disconnect unit from power source, and let cool.
2. Remove all detachable items such as wire shelves, side racks, and drip pans. Clean these items separately.
3. Wipe the interior metal surfaces of the oven with a paper towel to remove loose food debris.
4. Clean the interior metal surfaces of the cabinet with a damp clean cloth or sponge and any good commercial detergent.



- NOTE:** Avoid the use of abrasive cleaning compounds, chloride based cleaners, or cleaners containing quaternary salts. Never use hydrochloric acid (muriatic acid) on stainless steel.
5. Spray heavily soiled areas with a water soluble degreaser and let stand for 10 minutes, then remove soil with a plastic scouring pad.
  6. Wipe control panel, door vents, door handles, and door gaskets thoroughly since these areas harbor food debris.

7. Rinse surfaces by wiping with sponge and clean warm water.
8. Remove excess water with sponge and wipe dry with a clean cloth or air dry. Leave doors open until interior is completely dry. Replace side racks and shelves.
9. Wipe door gaskets and control panel dry with a clean, soft cloth.
10. Interior can be wiped with a non-quaternary sanitizing solution after cleaning and rinsing. This solution must be approved for use on stainless steel food contact surfaces.
11. To help maintain the protective film coating on polished stainless steel, clean the exterior of the cabinet with a cleaner recommended for stainless steel surfaces. Spray the cleaning agent on a clean cloth and wipe with the grain of the stainless steel.
12. Clean any glass with a window cleaner.

Always follow appropriate state or local health (hygiene) regulations regarding all applicable cleaning and sanitation requirements for equipment.

## DANGER



To prevent **SERIOUS PERSONAL INJURY, DEATH, or PROPERTY DAMAGE:**

**DO NOT** steam clean, hose down or flood the interior or exterior with water or liquid solution of any kind. **DO NOT** use water jet to clean.

Failure to observe this precaution will void the warranty.

## WARNING

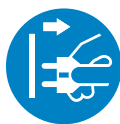

To prevent **SERIOUS INJURY, DEATH, OR PROPERTY DAMAGE,** **ALWAYS** disconnect unit from power source before cleaning or servicing.

# CARE AND CLEANING

## DAILY PROBE CLEANING AND HANDLING

1. Spray Dawn® detergent onto a bottle brush and scrub each probe for 2 minutes.
2. Allow the hot water from the faucet to run until it is hot. Rinse each probe under hot water.
3. Spray non-quaternary sanitizer solution onto each probe and allow to air dry.

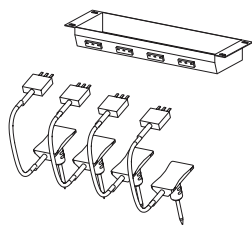

### Always:

- *Always* handle probes with care.
- *Always* pull the probe using the plastic head, not the cable.
- *Always* clean probes immediately after use; scrub with soap and water.
- *Always* hang probes on rack immediately after cleaning.

### Never:

- *Never* soak probes in the sink.
- *Never* remove probes from beef by the cable.
- *Never* unplug probes from oven by pulling cable.
- *Never* get probe cables caught in oven door.
- *Never* drop probes against the oven after they are pulled from beef.
- *Never* clean probes with harsh chemicals or bleach.

## WEEKLY CONTROL PANEL CLEANING

Lightly spray Dawn detergent onto a clean towel and wipe the control panel. **Do not use excessive moisture.**

## WEEKLY MANIFOLD CLEANING

1. Spray Dawn detergent onto a bottle brush and scrub the manifold completely.
2. Spray clean water onto a clean towel and wipe off the manifold.
3. Spray non-quaternary sanitizer solution onto a clean towel and wipe off the manifold.

**Note: Do not spray cleaning products directly into the manifold.**

## CHECK THE COOLING FAN

While the oven is warm, check that the cooling fan in the oven control area is functioning. The fan is located at the back of the unit, toward the top.

## CHECK OVERALL CONDITION OF OVEN

Check the oven once a month for physical damage and loose screws. Correct any problems before they begin to interfere with the operation of the oven.

## DO NOT USE OVEN IF CONTROLS ARE NOT PROPERLY FUNCTIONING

Refer to the Trouble Shooting Guide located in this manual or call an authorized service technician.

## CAUTION



To protect stainless steel surfaces, completely avoid the use of abrasive cleaning compounds, chloride based cleaners, or cleaners containing quaternary salts. **NEVER** use hydrochloric acid (muriatic acid) on stainless steel. **NEVER** use wire brushes, metal scouring pads or scrapers.

# SANITATION

Food flavor and aroma are usually so closely related that it is difficult, if not impossible, to separate them. There is also an important, inseparable relationship between cleanliness and food flavor. Cleanliness, top operating efficiency, and appearance of equipment contribute considerably to savory, appetizing foods. Good equipment that is kept clean, works better and lasts longer.

Most food imparts its own particular aroma and many foods also absorb existing odors. Unfortunately, during this absorption there is not distinction between GOOD and BAD odors. The majority of objectionable flavors and odors troubling food service operations are caused by bacteria growth. Sourness, rancidity, mustiness, stale or other OFF flavors are usually the result of germ activity.

The easiest way to insure full, natural food flavor is through comprehensive cleanliness. This means good control of both visible soil (dirt) and invisible soil (germs). A thorough approach to sanitation will provide essential cleanliness. It will assure an attractive appearance of equipment, along with maximum efficiency and utility. More importantly, a good sanitation program provides one of the key elements in the prevention of food-borne illnesses.

A controlled holding environment for prepared foods is just one of the important factors involved in the prevention of food-borne illnesses. Temperature monitoring and control during receiving, storage, preparation, and the service of foods are of equal importance.

The most accurate method of measuring safe temperatures of both hot and cold foods is by internal product temperature. A quality thermometer is an effective tool for this purpose, and should be routinely used on all products that require holding at a specific temperature.

A comprehensive sanitation program should focus on the training of staff in basic sanitation procedures. This includes personal hygiene, proper handling of raw foods, cooking to a safe internal product temperature, and the routine monitoring of internal temperatures from receiving through service.

Most food-borne illnesses can be prevented through proper temperature control and a comprehensive program of sanitation. Both these factors are important to build quality service as the foundation of customer satisfaction. Safe food handling practices to prevent food-borne illness is of critical importance to the health and safety of your customers.

HACCP, an acronym for Hazard Analysis (at) Critical Control Points, is a quality control program of operating procedures to assure food integrity, quality, and safety. Taking steps necessary to augment food safety practices is both cost effective and relatively simple. While HACCP guidelines go far beyond the scope of this manual, additional information is available by contacting:

*Center for Food Safety and Applied Nutrition  
Food and Drug Administration  
PHONE: 1-888-SAFEFOOD  
www.foodsafety.gov*

<b>INTERNAL FOOD PRODUCT TEMPERATURES</b>		
<b>HOT FOODS</b>		
DANGER ZONE	40°F TO 140°F	(4°C TO 60°C)
CRITICAL ZONE	70°F TO 120°F	(21°C TO 49°C)
SAFE ZONE	140°F TO 165°F	(60°C TO 74°C)
<b>COLD FOODS</b>		
DANGER ZONE	ABOVE 40°F	(ABOVE 4°C)
SAFE ZONE	36°F TO 40°F	(2°C TO 4°C)
<b>FROZEN FOODS</b>		
DANGER ZONE	ABOVE 32°F	(ABOVE 0°C)
CRITICAL ZONE	0°F TO 32°F	(-18°C TO 0°C)
SAFE ZONE	0°F or below	(-18°C or below)

## SERVICE

### **DANGER**



To prevent **SERIOUS INJURY, DEATH, OR PROPERTY DAMAGE**, ALWAYS lock-out or post breaker panel until service work has been completed.

### **NOTICE**

If the appliance has been unplugged for an extended period of time, the Real Time Clock may require recharging. Turn main breaker to the unit off for 10 seconds and then restore power. For more information, see Error Code E-60 in the Troubleshooting section of this manual.

### **WARNING**

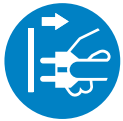

To prevent **SERIOUS INJURY, DEATH, OR PROPERTY DAMAGE**, ALWAYS disconnect unit from power source before cleaning or servicing.

ALWAYS check the circuit breaker is turned "ON" and your unit is receiving power BEFORE calling your Authorized Alto-Shaam Service Agent.

### **NOTICE**

This section is provided for the assistance of qualified and trained service technicians only and is not intended for use by untrained or unauthorized service personnel. Do not attempt to repair or service the oven beyond this point. Contact Alto-Shaam for the nearest authorized service agent. Repairs made by any other service agents without prior authorization by Alto-Shaam will void the warranty.

## **TROUBLE SHOOTING INTERNAL ELECTRICAL COMPONENTS**

### **A. No power. Display will not light.**

1. Verify that power is available at the outlet or junction box.
2. Verify that the On/Off switch on the front of the unit is turned on.
3. Verify that the power cord is not open. Check continuity with a VOM meter.
4. If the problem persists, call a qualified Alto-Shaam service technician at 1-800-558-8744.

### **B. To test air sensor:**

Test air sensor by placing sensor in ice water bath and using an ohmmeter set on the ohm scale. The reading should be 100 ohms resistance. If it is more than 2 ohms higher or lower, sensor needs to be replaced.

### **C. To test probe sensor:**

Test food probe by placing in ice water bath and using an ohmmeter set on the ohm scale. The reading should be 100 ohms resistance.

# SERVICE

## ERROR CODES

<b>Error Code</b>	<b>Action Required</b>
<b>E-B0</b>	PCB thermistor short. Replace control.
<b>E-B1</b>	PCB thermistor open. Replace control.
<b>E-B2</b>	PCB (control) over temperature. Check control cooling fan to make sure it is running, and vents for fan are clean. Verify that unit is not installed too close to a heat producing source. If problem persists, contact Service.
<b>E-10</b>	N6 short-circuit detected.
<b>E-11</b>	N6 open-circuit detected.
<b>E-20</b>	All active cook probes invalidated during current cook. Check all probes to ensure proper function. If problem persists contact Service.
<b>E-30</b>	N6 under [set-point - 25°F] for > 90-minutes.
<b>E-31</b>	N6 > [maximum cavity set-point + 25°F (145°F for food warmer)] for more than 120-seconds.
<b>E-41</b>	Touch error. Self correcting. If problem persists contact Service.
<b>E-43</b>	Touch controller not detected. Replace control.
<b>E-44</b>	Touch error. Self correcting. If problem persists contact Service.
<b>E-53</b>	Internal ADC error. Replace control.
<b>E-60</b>	Unit time has been reset. Check date and time. Invalid data seen for date/time. Reset time and date. If problem persists replace battery on PBC. (#2032).
<b>E-61</b>	Real-time clock chip not detected. Contact Service.
<b>E-64</b>	Real-time clock is detected, but time is not incrementing. Replace control.
<b>E-66</b>	Control Board processor reset. Self clearing. If problem persists contact Service.
<b>E-71</b>	Device ID/personality mismatch. Check Control Board version, update if necessary. Update software. If problem persists replace control.
<b>E-80</b>	Bad checksum. Check all parameters. Self-resetting.
<b>E-83</b>	EEPROM not detected. Contact Service.
<b>E-84</b>	Bad checksum. EEPROM user options reset. Check all parameters. Self resetting. Check all user settings for changes.
<b>E-92</b>	Operational mode mismatch between control board and interface board. Clears after acknowledgement. If problem persists contact Service.
<b>E-94</b>	Communication failure.
<b>E-96</b>	S-Pod not detected. Verify that S-Pod is connected and green light is on.
<b>E-SD</b>	Reseat card. Contact factory if problem persists.
<b>E-BC</b>	CB update EEPROM not detected. Contact Service.
<b>ECFG</b>	Application error. Reinstall Interface Board and Control Board software (current version or newer). If errors persist contact Service.
<b>EPRG</b>	Application error. Reinstall Interface Board and Control Board software (current version or newer). If errors persist contact Service.
<b>EP**</b>	Application error. Reinstall Interface Board and Control Board software (current version or newer). If errors persist contact Service.
<b>EX10</b>	X represents the probe (1-6). Any EX10 error indicates that a short circuit was detected on that probe and it is not functioning. Test the probe connector with a known good probe. If problem resolves, replace the faulty probe. If problem persists, replace the manifold. If problem still persists, replace the control board.
<b>PX60</b>	X represents the probe (1-6). Any PX60 error indicates that the product connected to the identified probe took longer than 6 hours to achieve the required internal temperature. Product should be evaluated and/or discarded.
<b>PX30</b>	X represents the probe (1-6). Any PX30 error indicates that the product connected to the identified probe dropped outside the safe temperature threshold by 5°F or more after it had previously achieved the required temperature threshold. Product should be evaluated and/or discarded.

# SERVICE

## EXTERIOR VIEW- FULL

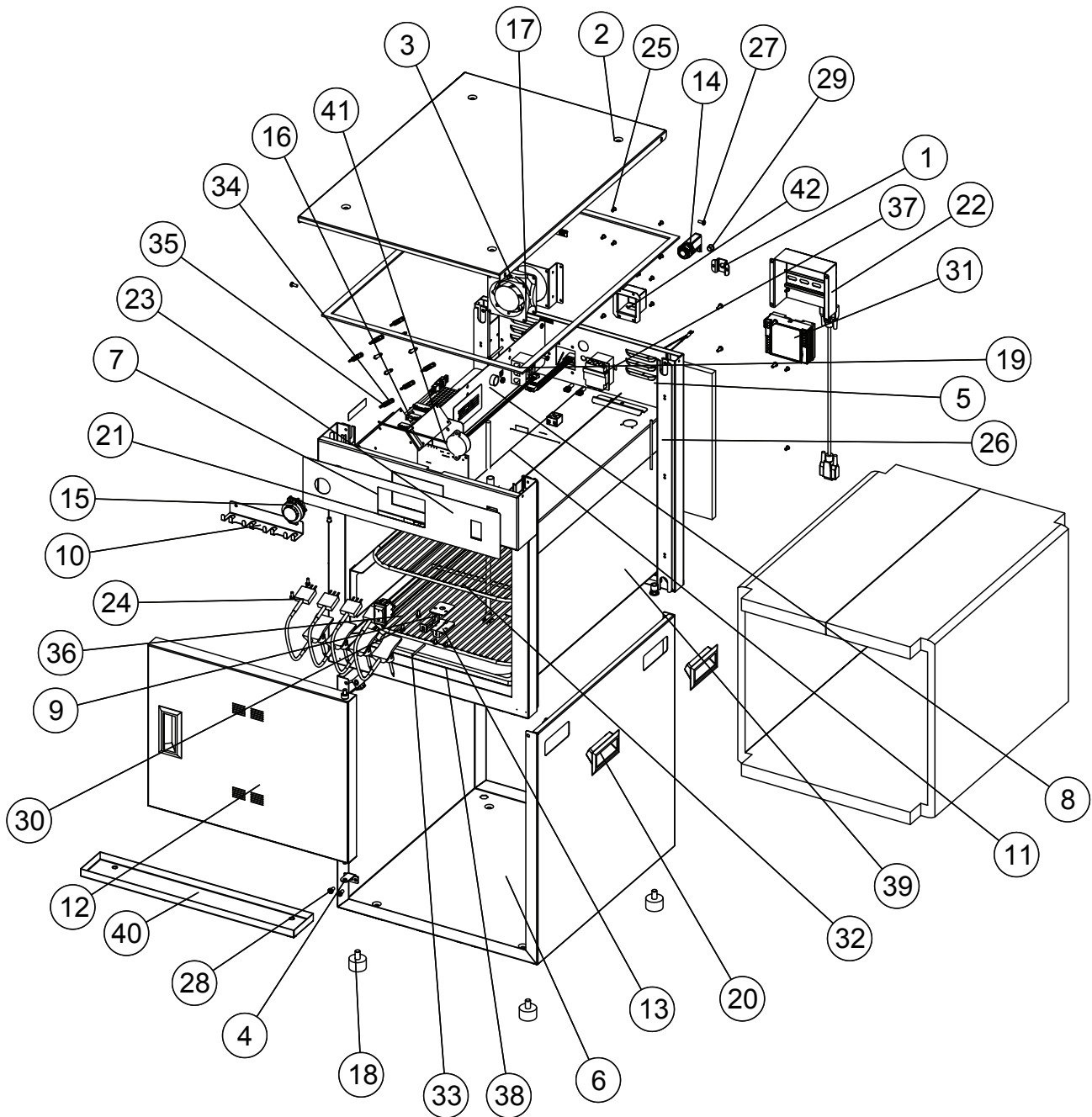

Part numbers and drawings are subject to change without notice.

# SERVICE

## EXTERIOR VIEW- FULL

Item	Description	Part	Qty
1	HI-LIMIT PROTECTION COVER	1003936	1
2	TOP COVER	1012831	1
3	FAN BRACKET	1012875	1
4	HINGE PLATE, RH	1012999	1
5	PANEL, REAR TRIM	1016356	1
6	OUTER CASING	1016357	1
7	BRACKET, CONTROL SUPPORT	1016361	1
8	BRACKET, ELEC CHASSIS, AIR SHIELD	1016809	1
9	GUARD SENSOR, W/MW	1493	1
10	BRACKET, PROBE HOLDER	1016874	1
11	WELD ASSY, TUBE TO FRONT TRIM	5017508	1
12	DOOR ASSY, RH SLAB,VENTS	5017981	1
13	ELEC. CONTROL SENSOR BLOCK	BK-29605	1
14	BUSHING, STRAIN RELIEF, 90°	BU-34898	1
15	CONNECTOR, USB, PANEL MOUNT	CB-35746	1
16	CONTROL, BOARD W/FIRMWARE	CC-38007	1
17	FAN, BOX, 115V, 34CFM	FA-3973	1
18	FEET, 3/4" HEIGHT, 3/8-16 X 5/6 THREAD	FE-29203	4
19	GASKET, WITH ADHESIVE 0.125 x 0.375 [6.5ft]	GS-23622	1
20	HANDLE, PULL RECESSED, BLACK, 1.830 x 3.860	HD-28789	5
21	PANEL, OVERLAY	PE-37001	1
22	SPOT ASSY, COMM BOX	5018093	1
23	PROBE, MANIFOLD, 4 BANK (SEE NEXT DRAWING)	PR-37002	1
24	PROBE, FOOD, 1000 OHM RTD	PR-38005	4
25	RIVET, BLIND, #44, S/S	RI-2100	13
26	SCREW, M4 x 0.7 x 6mm PAN	SC-22271	2
27	SCREW, M4 x 0.7 x 10mm PAN	SC-22273	12
28	SCREW, M5 x 0.8 x 10mm PAN	SC-22766	2
29	3/8" HOLE PLUG	PG-25574	1
30	SCREW, M4 x 0.7 x 10mm HEX	SC-23664	4
31	SITESAGE, CONTROL KIT	5019895	1
32	SHELF, 15" x 20" S/S	SH-2326	2
33	SENSOR, 1-3/4" LENGTH	SN-33541	1
34	SPACER, SUPPORT, NYLON	SP-33707	6
35	SPACER, 7/16" NYLON	SP-33901	6
36	SWITCH, ROCKER, 125-277V, 20A	SW-34769	1
37	THERMOSTAT, 300°F HI-LIMIT	TT-33476	1
38	PAN, FULL SIZE, 3/4" HEIGHT, S/S	PN-37119	1
39	ELEMENT, 800W, 120V	EL-35173	1
40	DRIP TRAY	1010783	1
41	BUZZER ASSY, WITH CONNECTOR	5018422	1
42	SERIAL CABLE MOUNTING BOX	1018249	1

## WARNING

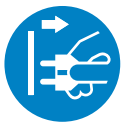

To prevent **SERIOUS INJURY, DEATH, OR PROPERTY DAMAGE**, ALWAYS disconnect unit from power source before cleaning or servicing.

## ⚠ DANGER



To prevent **SERIOUS INJURY, DEATH, OR PROPERTY DAMAGE**, ALWAYS lock-out or post breaker panel until service work has been completed.

# SERVICE

## EXTERIOR VIEW- FRONT

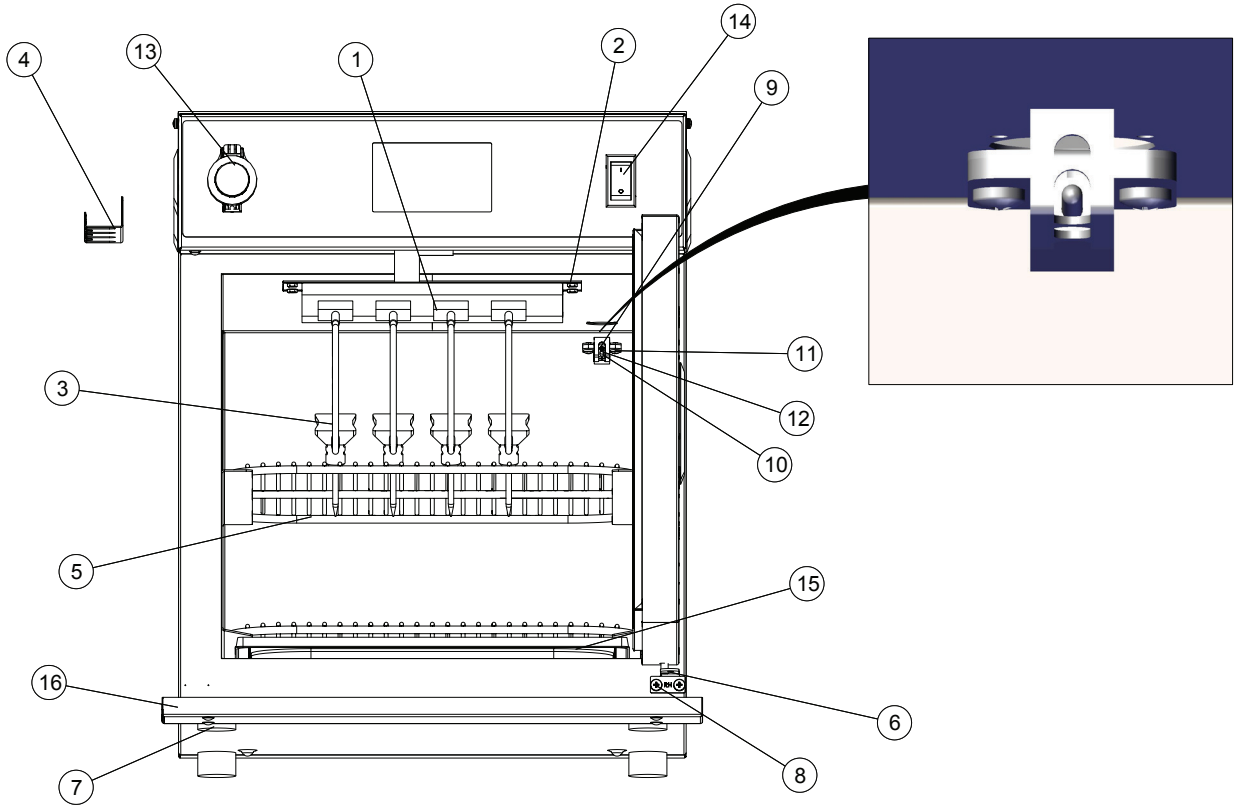

Item	Description	Part	Qty
1	PROBE, MANIFOLD, 4 BANK, RTD	<a href="#">PR-37002</a>	1
2	SCREW, M4 x 0.7 x10mm HEX	<a href="#">SC-23664</a>	4
3	PROBE, FOOD, 1000 OHM RTD	<a href="#">PR-38005</a>	4
4	BRACKET, PROBE HOLDER	1016874	1
5	15" X 20" SHELF, S/S	<a href="#">SH-2326</a>	2
6	RH HINGE PLATE	<a href="#">1012999</a>	1
7	FEET, 3/4" HEIGHT, 3/8-16 X 5/6 THREAD	<a href="#">FE-29203</a>	4
8	SCREW, M5 x 0.8 x10mm PAN	<a href="#">SC-22766</a>	2
9	GUARD SENSOR, W/MW	<a href="#">1493</a>	1

Item	Description	Part	Qty
10	ELEC. CONTROL SENSOR BLOCK	<a href="#">BK-29605</a>	1
11	SCREW, M4 x 0.7 x 6mm PAN	<a href="#">SC-22271</a>	2
12	SENSOR, 1-3/4" LENGTH	<a href="#">SN-33541</a>	1
13	CONNECTOR, USB, PANEL MOUNT	<a href="#">CB-35746</a>	1
14	SWITCH, ROCKER, 125-277V, 20A	<a href="#">SW-34769</a>	1
15	PAN, FULL SIZE, 3/4" HEIGHT, S/S	<a href="#">PN-37119</a>	1
16	DRIP TRAY	<a href="#">1010783</a>	1

## WARNING

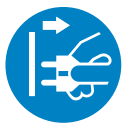

To prevent **SERIOUS INJURY, DEATH, OR PROPERTY DAMAGE**, ALWAYS disconnect unit from power source before cleaning or servicing.

## ! DANGER



To prevent **SERIOUS INJURY, DEATH, OR PROPERTY DAMAGE**, ALWAYS lock-out or post breaker panel until service work has been completed.

Part numbers and drawings are subject to change without notice.

# SERVICE

## EXTERIOR VIEW - TOP

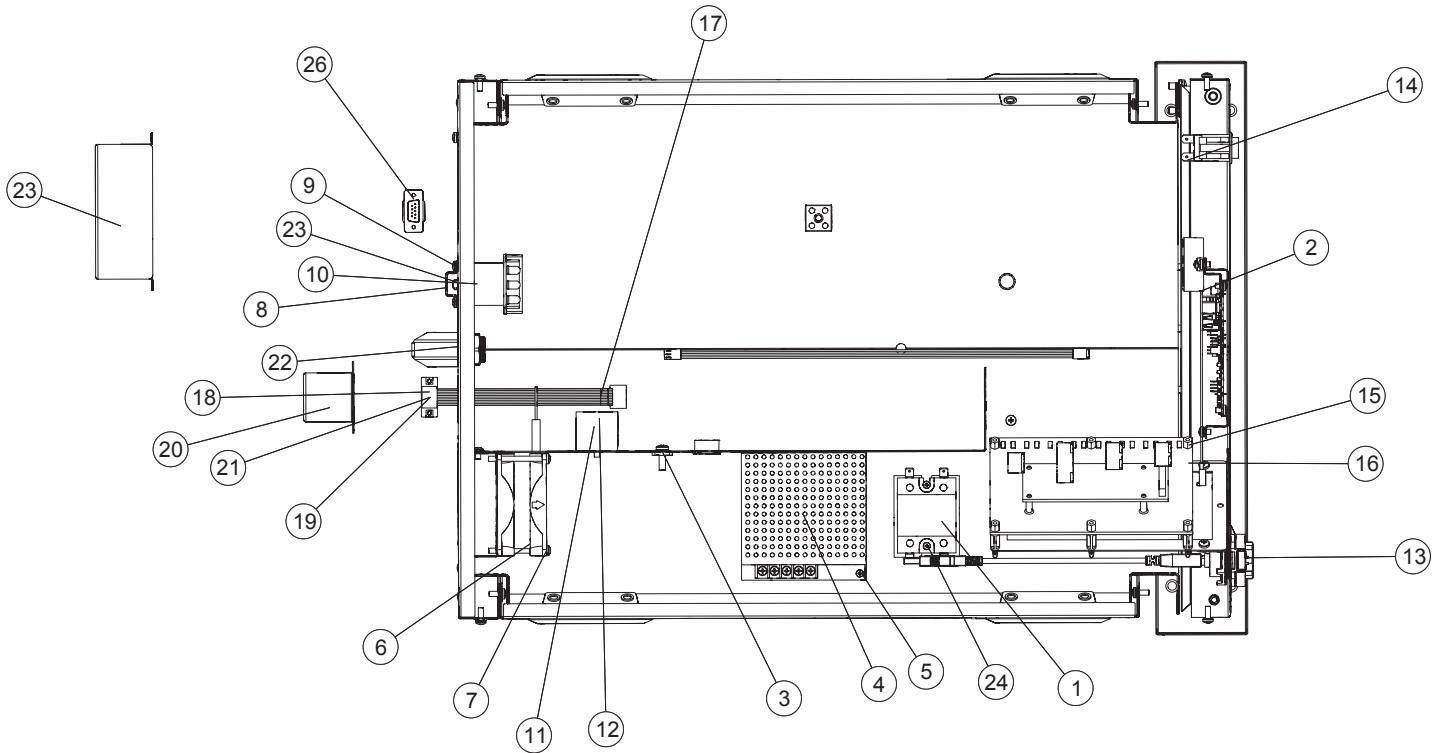

Item	Description	Part	Qty
1	RELAY, SOLID STATE, 230V, 25A	<a href="#">RL-33829</a>	1
2	BUZZER ASSY, WITH CONNECTOR	<a href="#">5018422</a>	1
3	SCREW, PAN PH, METRIC, M5	<a href="#">SC-36973</a>	1
4	BOARD, POWER SUPPLY, 12V 50W	<a href="#">BA-36144</a>	1
5	SCREW, M3 x 0.5 x 8mm PAN	<a href="#">SC-22268</a>	2
6	FAN, BOX, 115V, 34CFM	<a href="#">FA-3973</a>	1
7	SCREW, M4 x 0.7 x 45mm PAN	<a href="#">SC-28142</a>	2
8	HI-LIMIT PROTECTION COVER	<a href="#">1003936</a>	1
9	SCREW, M4 x 0.7 x 6mm PAN	<a href="#">SC-22271</a>	2
10	THERMOSTAT, 300F HI-LIMIT	<a href="#">TT-33476</a>	1
11	T-BLOCK	<a href="#">BK-3019</a>	1
12	SCREW, M4 x 0.7 x 30mm PAN	<a href="#">SC-29276</a>	2
13	CONNECTOR, USB, PANEL MOUNT	<a href="#">CB-35746</a>	1

Item	Description	Part	Qty
14	SWITCH, ROCKER, 125-277V, 20A	<a href="#">SW-34769</a>	1
15	SPACER, SUPPORT, NYLON 1.4"	<a href="#">SP-33707</a>	5
16	SPACER, 7/16" NYLON	<a href="#">SP-33901</a>	5
17	CABLE, FLAT RIBBON, 28" LONG, 10 WIRE	<a href="#">CB-36986</a>	1
18	CAP, DUST, CONNECTOR, PLASTIC	<a href="#">CP-36970</a>	1
19	CONNECTOR, DSUB, FEMALE 9 PIN	<a href="#">CR-36971</a>	1
20	SERIAL CABLE MOUNTING BOX	<a href="#">1018249</a>	1
21	CABLE, ASSY, 300-TH/III TOUCH	<a href="#">5018092</a>	1
22	BUSHING, STRAIN RELIEF, 90°	<a href="#">BU-34898</a>	1
23	SPOT ASSY, COMM BOX	<a href="#">5018093</a>	1
24	SCREW, M3 x 0.5 x 8mm PAN	<a href="#">SC-22268</a>	2
26	SITESAGE, CONTROL KIT	<a href="#">5019895</a>	1

## WARNING

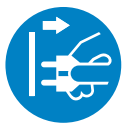

To prevent **SERIOUS INJURY, DEATH, OR PROPERTY DAMAGE**, ALWAYS disconnect unit from power source before cleaning or servicing.

## ⚠ DANGER



To prevent **SERIOUS INJURY, DEATH, OR PROPERTY DAMAGE**, ALWAYS lock-out or post breaker panel until service work has been completed.

Part numbers and drawings are subject to change without notice.

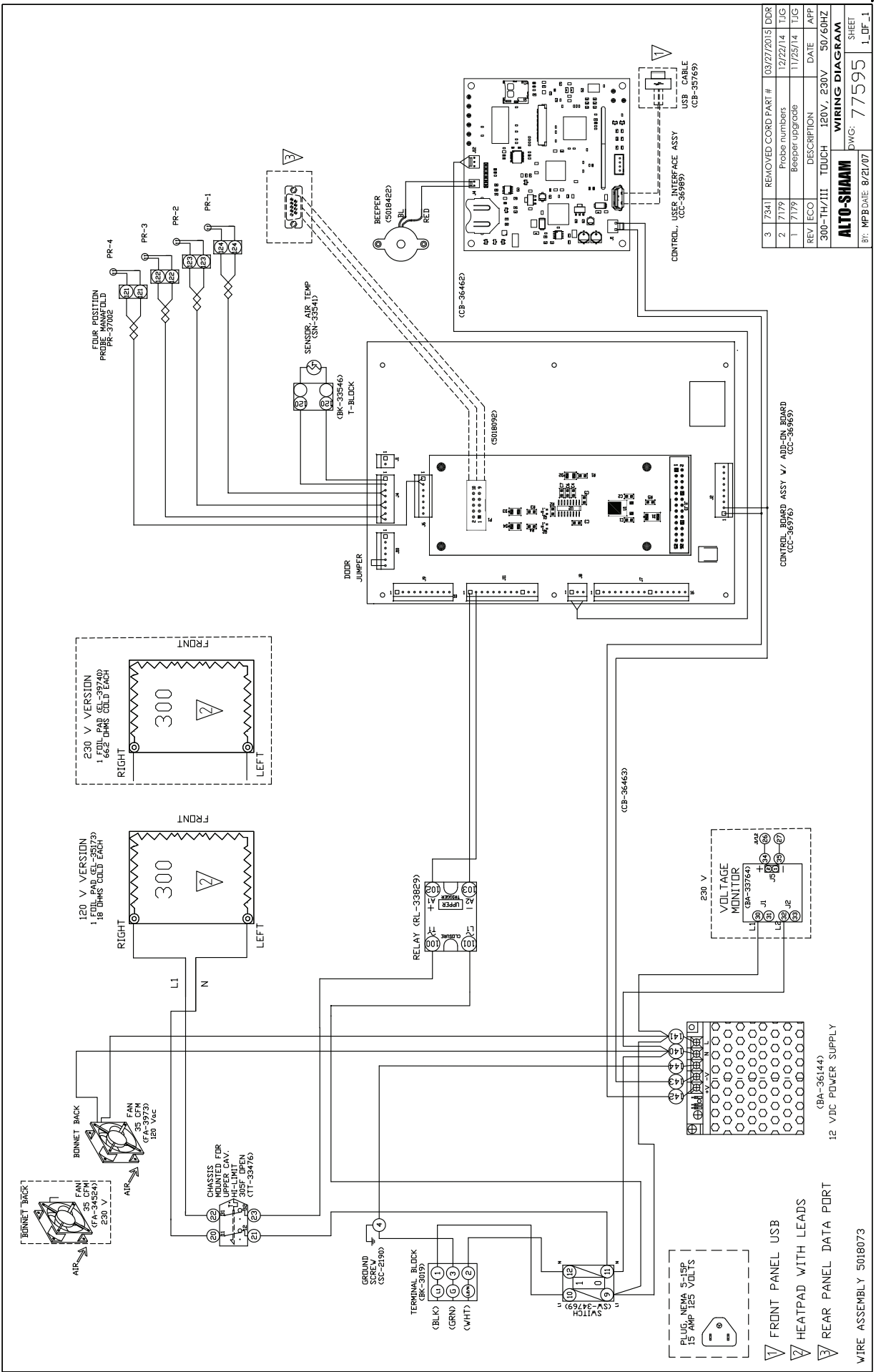

3	7341	REMOVED CORD PART #	03/27/2015	DDR
2	7179	Probe numbers	12/22/14	TJG
1	7179	Beeper upgrade	11/25/14	TJG
REV	ECCO	DESCRIPTION	DATE	APP
300-TH/III	TOUCH	120V, 230V	50/60HZ	
<b>ALTO-SHAAM</b>				<b>WIRING DIAGRAM</b>
DWG: 77595				SHEET
BY: MPB DATE: 8/21/07				1_DF_1

# TRANSPORTATION DAMAGE and CLAIMS



All Alto-Shaam equipment is sold F.O.B. shipping point, and when accepted by the carrier, such shipments become the property of the consignee.

Should damage occur in shipment, do not put the appliance into service until the damage has been inspected by an authorized Alto-Shaam service provider.

Shipping damages are a matter between the carrier and the consignee. In such cases, the carrier is assumed to be responsible for the safe delivery of the merchandise, unless negligence can be established on the part of the shipper.

1. Make an immediate inspection while the equipment is still in the truck or immediately after it is moved to the receiving area. Do not wait until after the material is moved to a storage area.
2. Do not sign a delivery receipt or a freight bill until you have made a proper count and inspection of all merchandise received.
3. Note all damage to packages directly on the carrier's delivery receipt.
4. Make certain the driver signs this receipt. If he refuses to sign, make a notation of this refusal on the receipt.
5. If the driver refuses to allow inspection, write the following on the delivery receipt:  
*Driver refuses to allow inspection of containers for visible damage.*
6. Telephone the carrier's office immediately upon finding damage, and request an inspection. Mail a written confirmation of the time, date, and the person called.
7. Save any packages and packing material for further inspection by the carrier.
8. Promptly file a written claim with the carrier and attach copies of all supporting paperwork.

We will continue our policy of assisting our customers in collecting claims which have been properly filed and actively pursued. We cannot, however, file any damage claims for you, assume the responsibility of any claims, or accept deductions in payment for such claims.

## LIMITED WARRANTY

Alto-Shaam, Inc. warrants to the original purchaser only that any original part that is found to be defective in material or workmanship will, at Alto-Shaam's option, subject to provisions hereinafter stated, be replaced with a new or rebuilt part.

### The original parts warranty period is as follows:

For the refrigeration compressor on Alto-Shaam Quickchillers™, five (5) years from the date of installation of appliance.

For the heating element on Halo Heat® cooking and holding ovens, as long as the original purchaser owns the oven. This excludes holding only equipment.

For all other original parts, one (1) year from the date of installation of appliance or fifteen (15) months from the shipping date, whichever occurs first.

The labor warranty period is one (1) year from the date of installation or fifteen (15) months from the shipping date, whichever occurs first.

Alto-Shaam will bear normal labor charges performed during standard business hours, excluding overtime, holiday rates or any additional fees.

To be valid, a warranty claim must be asserted during the applicable warranty period. This warranty is not transferable.

### THIS WARRANTY DOES NOT APPLY TO:

1. Calibration.
2. Replacement of light bulbs, door gaskets, and/or the replacement of glass due to damage of any kind.
3. Equipment damage caused by accident, shipping, improper installation or alteration.
4. Equipment used under conditions of abuse, misuse, carelessness or abnormal conditions, including but not limited to, equipment subjected to harsh or inappropriate chemicals, including but not limited to, compounds containing chloride or quaternary salts, poor water quality, or equipment with missing or altered serial numbers.
5. Damage incurred as a direct result of poor water quality, inadequate maintenance of steam generators and/or surfaces affected by water quality. Water quality and required maintenance of steam generating equipment is the responsibility of the owner/operator.
6. Damage caused by use of any cleaning agent other than Alto-Shaam's Combitherm® Cleaner, including but not limited to damage due to chlorine or other harmful chemicals. **Use of Alto-Shaam's Combitherm® Cleaner on Combitherm® ovens is highly recommended.**
7. Any losses or damage resulting from malfunction, including loss of product, food product, revenue, or consequential or incidental damages of any kind.
8. Equipment modified in any manner from original model, substitution of parts other than factory authorized parts, removal of any parts including legs, or addition of any parts.

This warranty is exclusive and is in lieu of all other warranties, express or implied, including the implied warranties of merchantability and fitness for a particular purpose. In no event shall Alto-Shaam be liable for loss of use, loss of revenue or profit, or loss of product, or for any indirect, special, incidental, or consequential damages. No person except an officer of Alto-Shaam, Inc. is authorized to modify this warranty or to incur on behalf of Alto-Shaam any other obligation or liability in connection with Alto-Shaam equipment.



Effective November 1, 2012

RECORD THE MODEL AND SERIAL NUMBER OF THE APPLIANCE FOR EASY REFERENCE.

ALWAYS REFER TO BOTH MODEL AND SERIAL NUMBER IN ANY CONTACT WITH ALTO-SHAAM REGARDING THIS APPLIANCE.

Model: \_\_\_\_\_ Date Installed: \_\_\_\_\_  
Voltage: \_\_\_\_\_ Purchased From: \_\_\_\_\_  
Serial Number: \_\_\_\_\_

W164 N9221 Water Street • P.O. Box 450 • Menomonee Falls, Wisconsin 53052-0450 • U.S.A.

PHONE: 262.251.3800 • 800.558-8744 USA/CANADA FAX: 262.251.7067 • 800.329.8744 U.S.A. ONLY

www.alto-shaam.com

PRINTED IN U.S.A.