

QC3 QuickChillers

Under-Counter, Reach-In,
and Roll-In



Manufacturer's Information

Copyright

© Copyright 04/26 by Alto-Shaam, Inc.
 All rights reserved.
 This manual or any portion thereof may not be reproduced or used in any manner whatsoever without the express written permission of Alto-Shaam, Inc

Trademarks

All trademarks referenced in this documentation are the property of their respective owners.

Manufacturer

Alto-Shaam, Inc.
 P.O. Box 450
 W164 N9221 Water Street
 Menomonee Falls, WI 53052

Models Covered

QC3-3 QC3-20 QC3-40 QC3-100 QC3-100R	US (UL Certified) Models
--	--------------------------

Serial Number

The unit serial number is required for identifying and ordering the correct service parts.
 Record the unit serial number below for reference.

Serial Number

Parts Finder Tool

Interactive diagrams from this Parts Manual are available online at our Parts Finder Tool:
<https://www.alto-shaam.com/en/customer-support/parts>.
 Or, scan the QR code below.

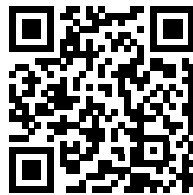

Parts Ordering Information

Original manufacturer's replacement parts may be ordered directly from the Alto-Shaam network of Authorized Service Agents and Parts Distributors. Follow this link for a map to a local partner: <https://www.alto-shaam.com/en/how-to-buy>. If you are an Authorized Service Agent or Parts Distributor, please submit your purchase order to parts@alto-shaam.com.

Non-OEM parts may be substituted; however, these parts must be of equal quality and specifications as those provided by Alto-Shaam.

Table of Contents

- Manufacturer’s Information2
- Table of Contents3
- QC3-3 Bottom4
- QC3-3 Box View5
- QC3-3 Coil6
- QC3-3 Compressor7
- QC3-3 Control Box8
- QC3-20 Box9
- QC3-20 Optional Side Rack10
- QC3-20 Coil11
- QC3-20 Compressor12
- QC3-20 Control Panel13
- QC3-40 Compressor14
- QC3-40 Compressor Housing15
- QC3-40 Coil16
- QC3-40 Door17
- QC3-40 Pan Supports18
- QC3-40 Control Panel19
- QC3-100 Compressor20
- QC3-100 Coil21
- QC3-100 Door22
- QC3-100 Interior (LH door shown).....23
- QC3-100/NT Narrow Trolley (LH door shown).....24
- QC3-100 Control Panel (LH shown)25

QC3-3 Bottom

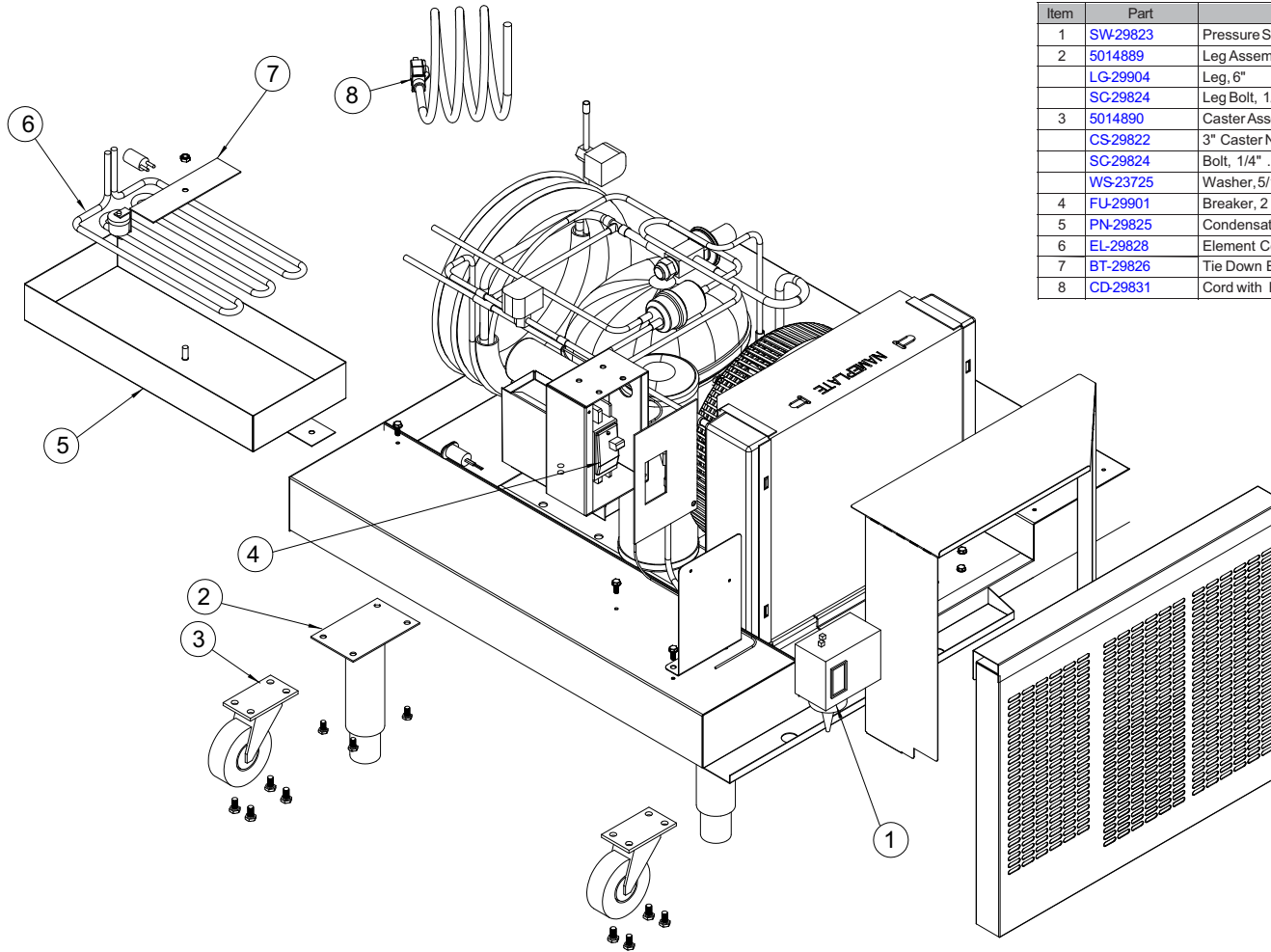

Item	Part	Description	Qty.
1	SW-29823	Pressure Switch	1
2	5014889	Leg Assembly (Set of 4)	1
	LG-29904	Leg, 6"	4
	SC-29824	Leg Bolt, 1/4-20 x 3.5" Shoulder Bolt Hex Head	16
3	5014890	Caster Assembly	1
	CS-29822	3" Caster Non-Locking, Option	4
	SC-29824	Bolt, 1/4" .20" x 5" Shoulder	16
	WS-23725	Washer, 5/16"ID, 3/4" OD, .042 thick	16
4	FU-29901	Breaker, 2 Pole 20 Amp, QOU220 Universal	1
5	PN-29825	Condensate Evaporator Pan	1
6	EL-29828	Element Condensate Pan, 115V200WEvap. 000274N	1
7	BT-29826	Tie Down Bracket for Elect Condensate Evaporator Heater	1
8	CD-29831	Cord with Plug, 20Amp 125V/5-20P, 9' Long	1

5900000_0

QC3-3 Box View

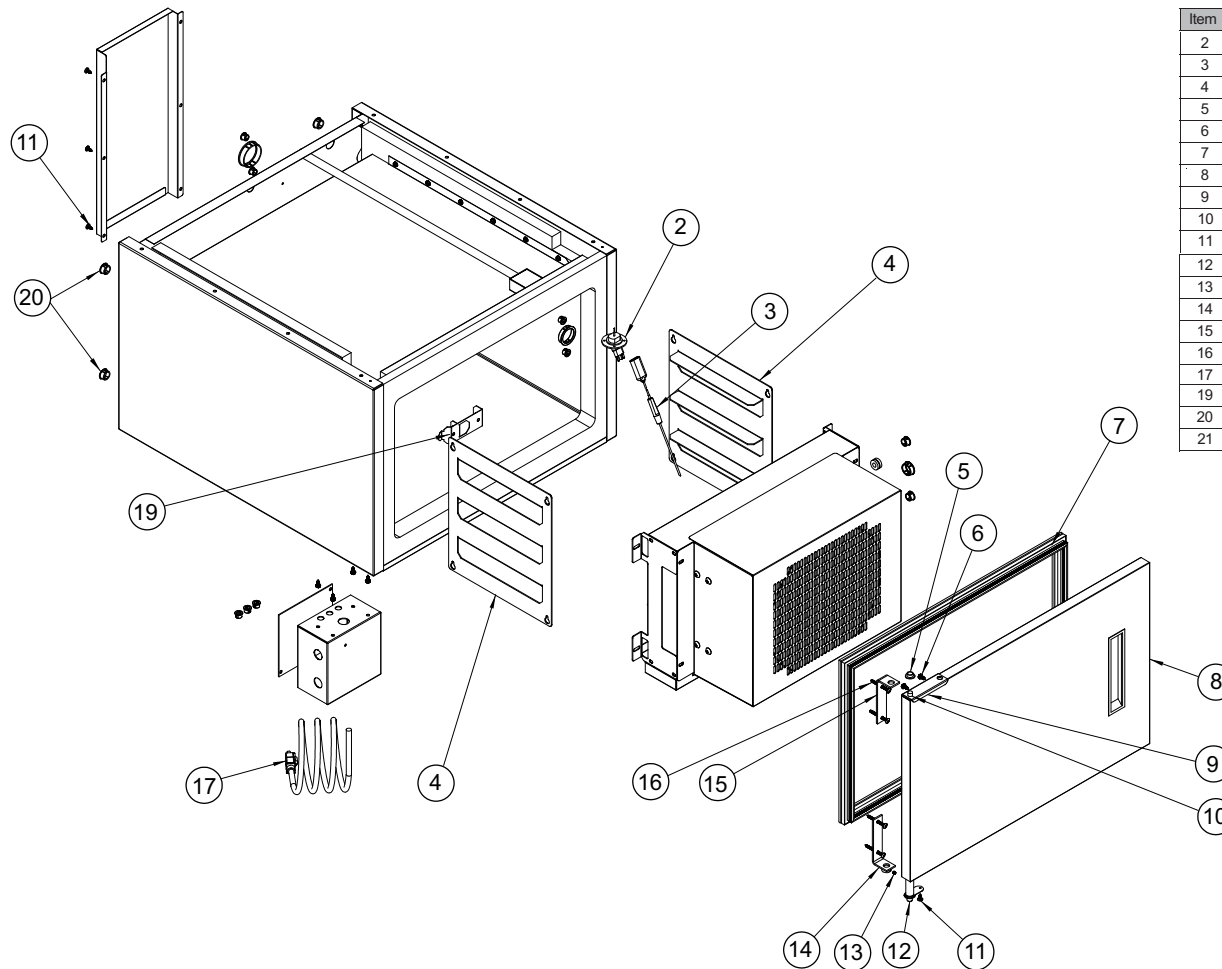

Item	Part	Description	Qty.
2	PR-35771	Probe Receptacle Assembly	1
3	PR-36201	Probe, Quick Connect	1
4	SR-29832	Stainless Steel Side Rack	2
5	BU-29937	Bushing, Nylon Hinge 118	1
6	SC-29839	Screw, 10x1/2" Slot	1
7	GS-29838	Gasket, 15.59 x 24.25 Push In Press In	1
8	DR-29833	Door, Hinged Left	1
9	HG-35736	Hinge, Top Door, Left Hand Channel	1
10	PI-35930	Hinge Pin	1
11	SC-29835	Screw, 10x1/2" T/H/P 410 S/S M4XG	1
12	HG-29834	Hinge, Spring Load Assembly	1
13	SC-29837	Screw, 1/4 -20 x 5/8" Socket Set 18-8 SS	1
14	HG-29836	Hinge, Strap w/Collar 38mm L-Shaped	1
15	HG-29960	Unit Hinge Bracket	1
16	SC-29910	Screw, 10x2" THP TYPE A S M62G 410SS	4
17	RE-29844	Cord, 2 Prong Male, for Fan	1
19	HL-29840	Food Probe Holder	1
20	PG-35098	Plug, 3/4" Grommet	5
21	ST-35099	Stud, Side Rack Mounting (not shown)	4

5900002_0

QC3-3 Coil

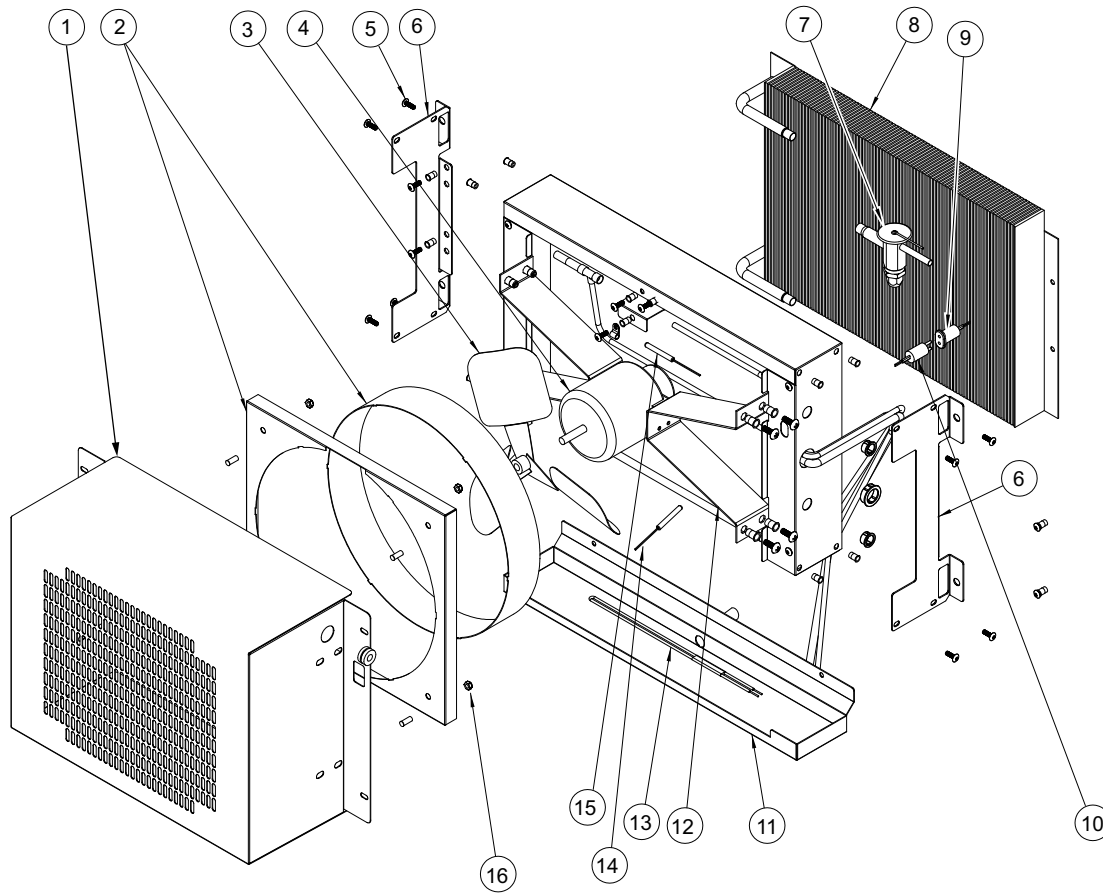

Item	Part	Description	Qty.
1	GD-29848	Fan Guard	1
2	GD-29850	Fan Shroud Assembly	1
3	FA-29854	Blade, 12" (305mm) Evaporator Fan	1
4	FA-29853	Motor, Fan ESPOL75EM14	1
5	SC-29855	Bolt, 10-24x5 Phillip Truss	19
6	BT-29847	Evaporator Coil Mounting Bracket	2
7	VA-29852	Valve, 1/4 Ton R404L-T MOP	1
8	RE-29846	Coil Assembly, 12x17-1/4 3EX-0802C	1
9	CD-29831	Cord, 2 Prong 24" (610mm) Female	1
10	CD-29858	Cord, 2 Prong 24" (610mm) Male	1
11	PN-29851	Drain Pan with Tubing, Evaporator BC-3	1
12	BT-29849	Fan Mounting Bracket	2
13	WI-35157	Wire, 11" (279mm) Loop, Drain Heater	1
14	PR-37483	Coil Sensor/, Defrost/Sensor	1
15	SN-33541	Sensor, 1-3/4" (44mm) Long	1
16	NU-29827	Nut, 10-24 Stainless Nylock	4

5900003_0

QC3-3 Compressor

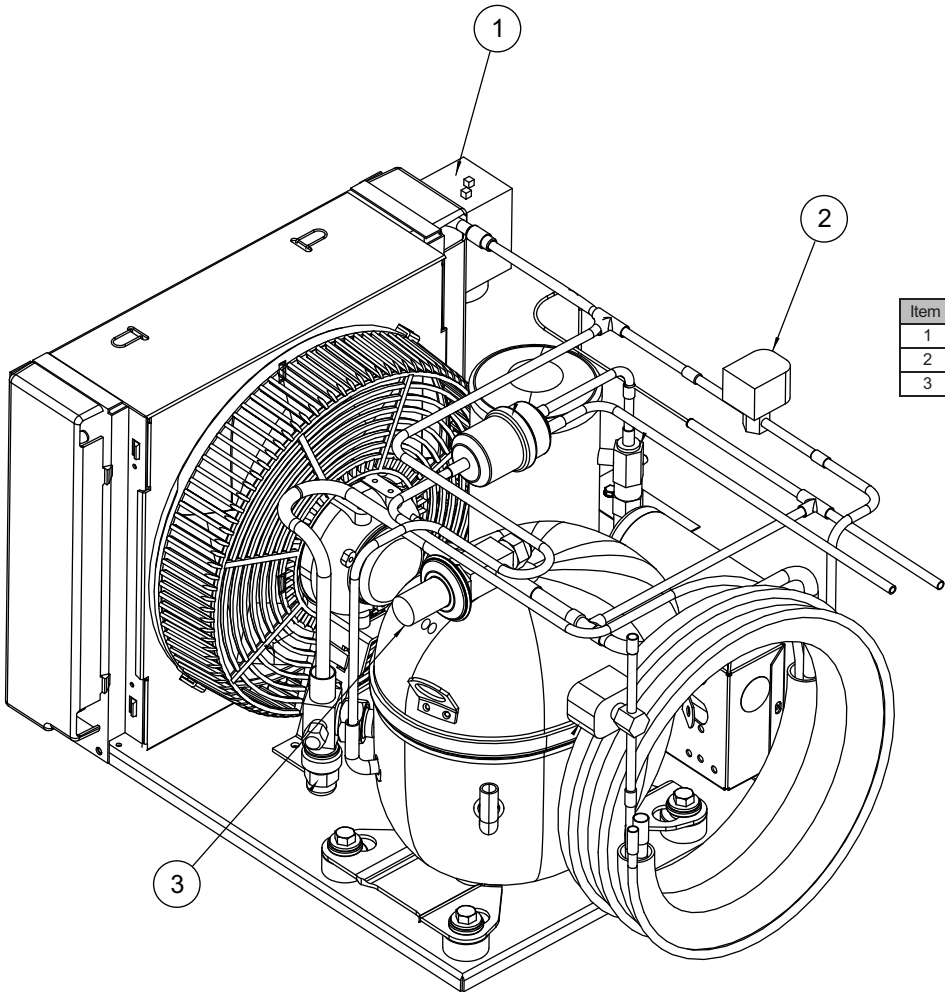

Item	Part	Description	Qty.
1	SW-29823	Pressure Switch	1
2	VA-29863	Solenoid Valve & 120V Coil	2
3	VA-29864	Valve, Sporlan CRO-4-0/75 Crankcase Pressure Reg.	1

5900004_0

QC3-3 Control Box

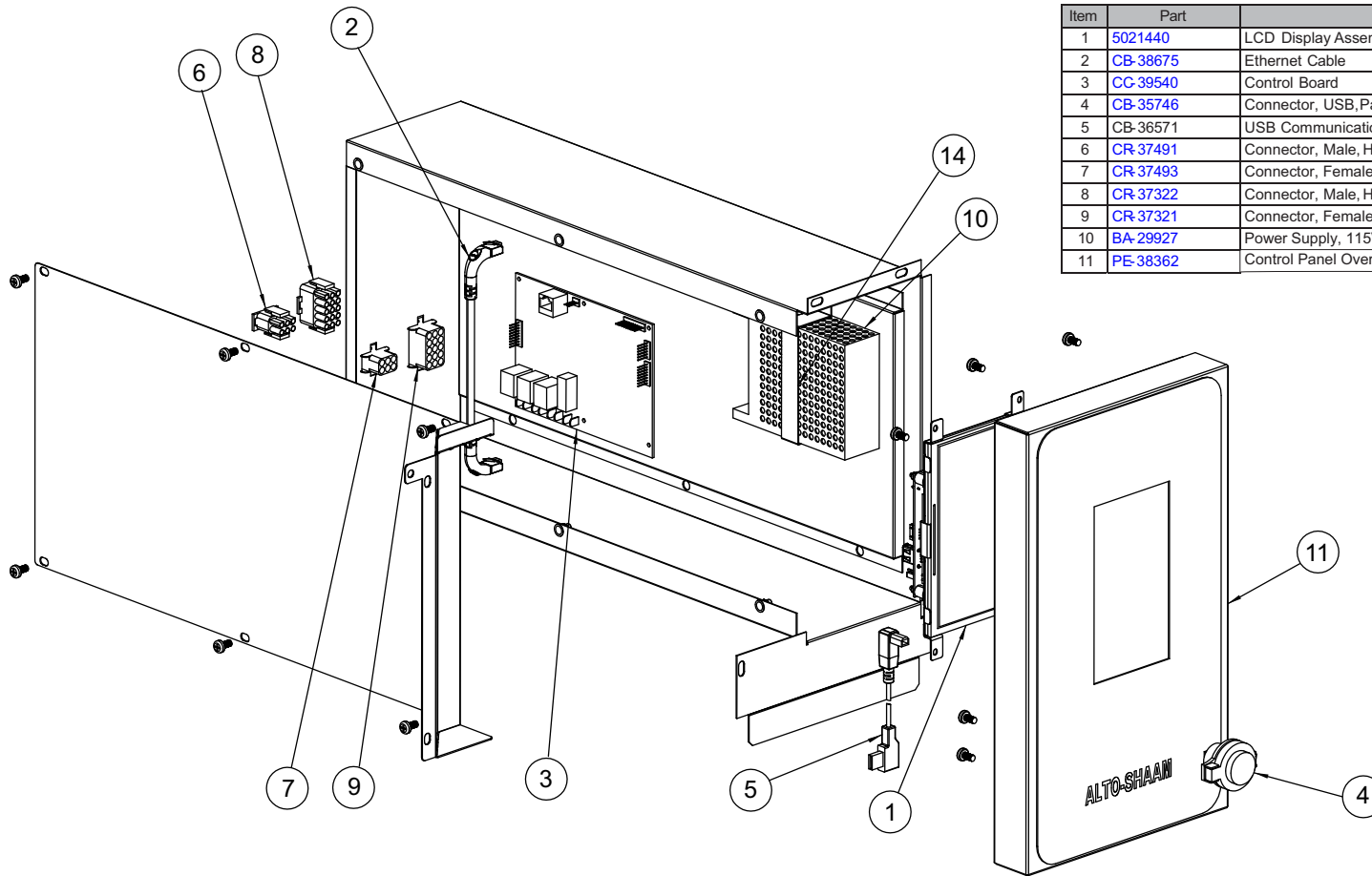

Item	Part	Description	Qty.
1	5021440	LCD Display Assembly, 7"	1
2	CB-38675	Ethernet Cable	1
3	CC-39540	Control Board	1
4	CB-35746	Connector, USB, Panel Mount	1
5	CB-36571	USB Communication Cable w/ plug	1
6	CR-37491	Connector, Male, Housing	1
7	CR-37493	Connector, Female, Housing	1
8	CR-37322	Connector, Male, Housing	1
9	CR-37321	Connector, Female, Housing	1
10	BA-29927	Power Supply, 115V to 12VDC	1
11	PE-38362	Control Panel Overlay	1

5900005_0

QC3-20 Box

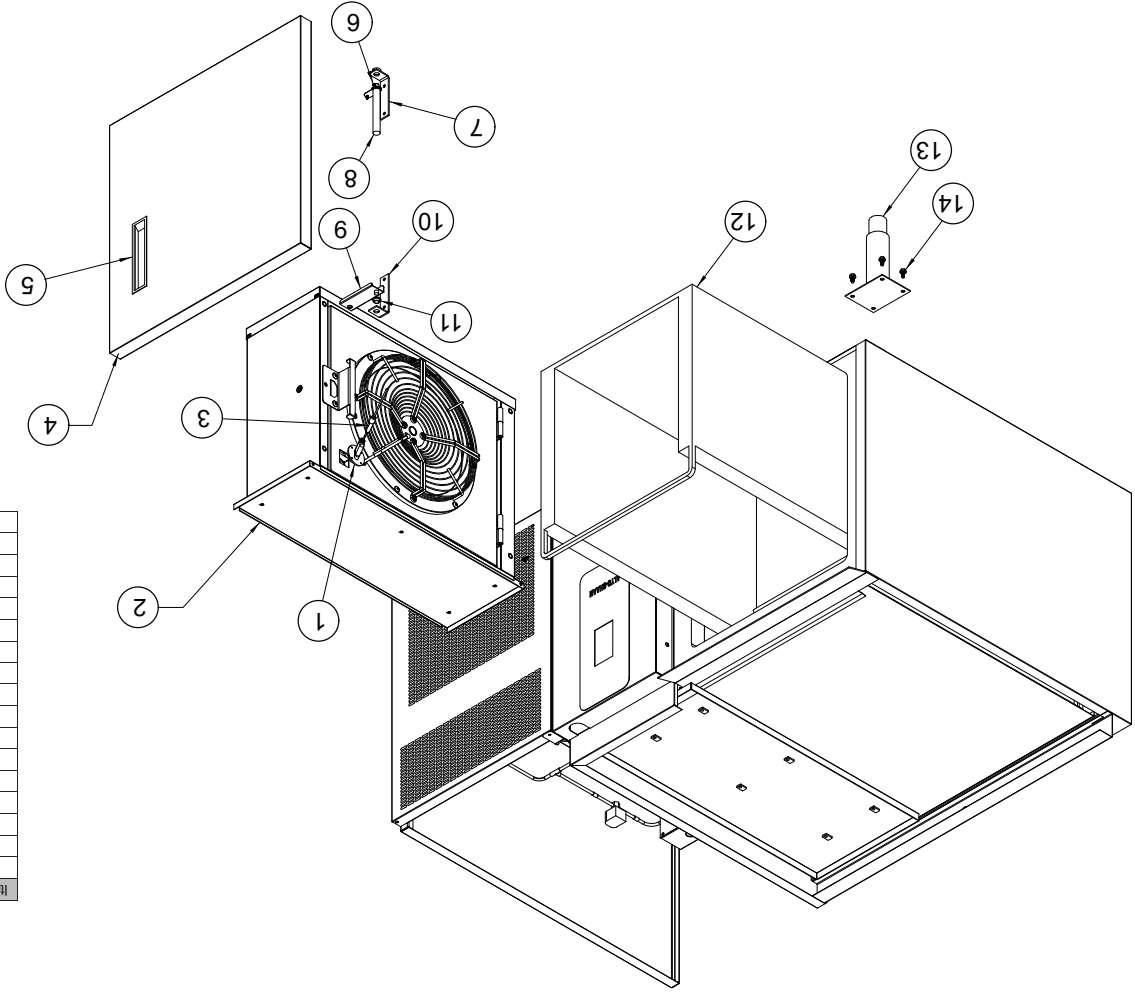

Item	Part	Description	Qty:
1	PR35771	Probe Receptacle Assembly	1
2	RS2905	Coil Assembly	1
3	PR36201	Probe, Product	1
4	DR29957	Door Assembly with Handle, Hinged Left	1
5	HD29958	Door Handle, Recessed	1
6	SC29837	Bolt, Black Set Screw	1
7	HG29836	Hinge, Strap w/ Collar 41mm, L-shaped	1
8	HG29834	Hinge, Self-Closing	1
9	HG29959	Hinge, Top Door, Left Hand Channel	1
10	HG29960	Hinge, Strap w/o Collar 38mm, L-shaped	1
11	BU29937	Bushing, Nylon Hinge	1
12	SR35827	Slide 9-Pan Rack, Standard	1
2	SR29969	Stainless Steel Slide Rack, Optional	2
13	5014889	Leg Assembly (Set of 4)	1
4	LG29904	Leg, 6"	4
16	SC29824	Leg Bolt, 1/4-20 X 3.5" Shoulder Bolt Hex	16

5900006_0

QC3-20 Optional Side Rack

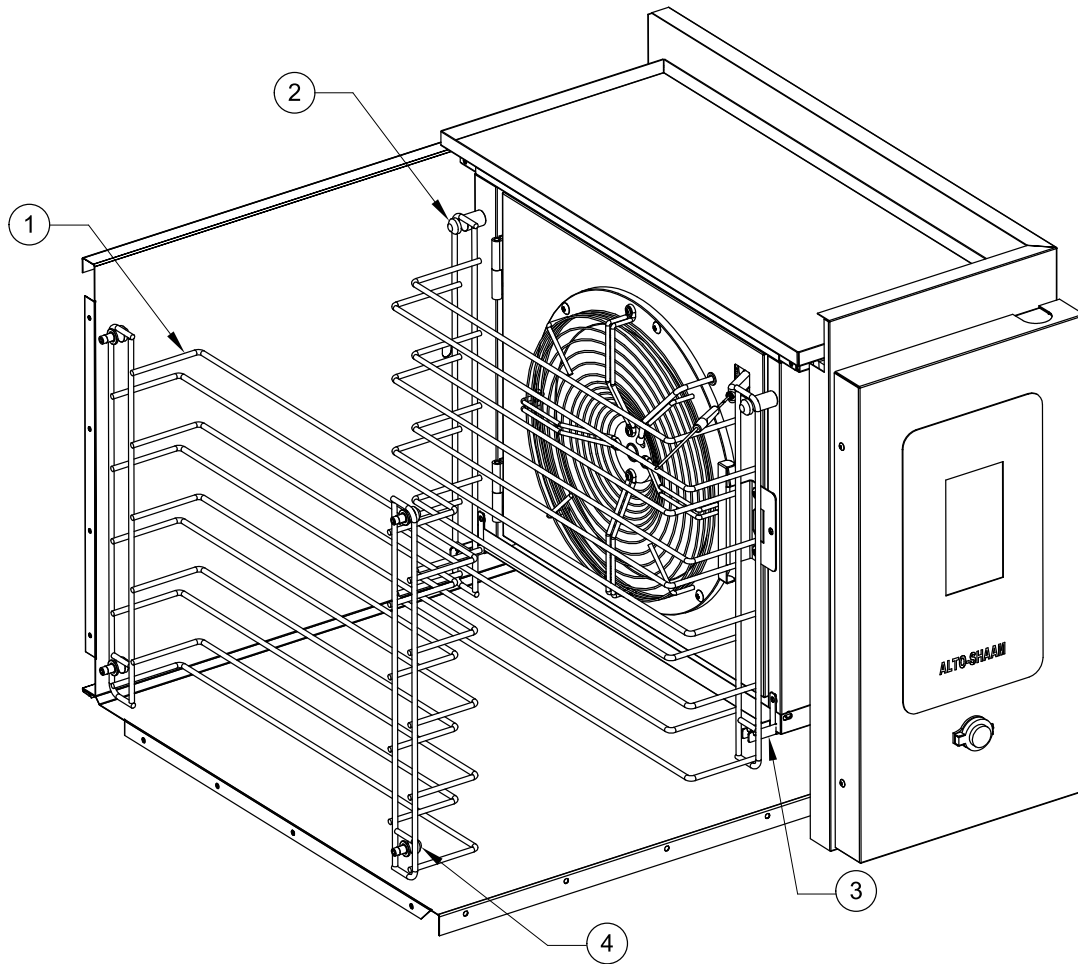

Item	Part	Description	Qty.
1	SR29969	Sideracks	2
2	PI-29939	Pins, long	2
3	BT-29942	Bracket	2
4	PI-35828	Pins, short	4

5900007_0

QC3-20 Coil

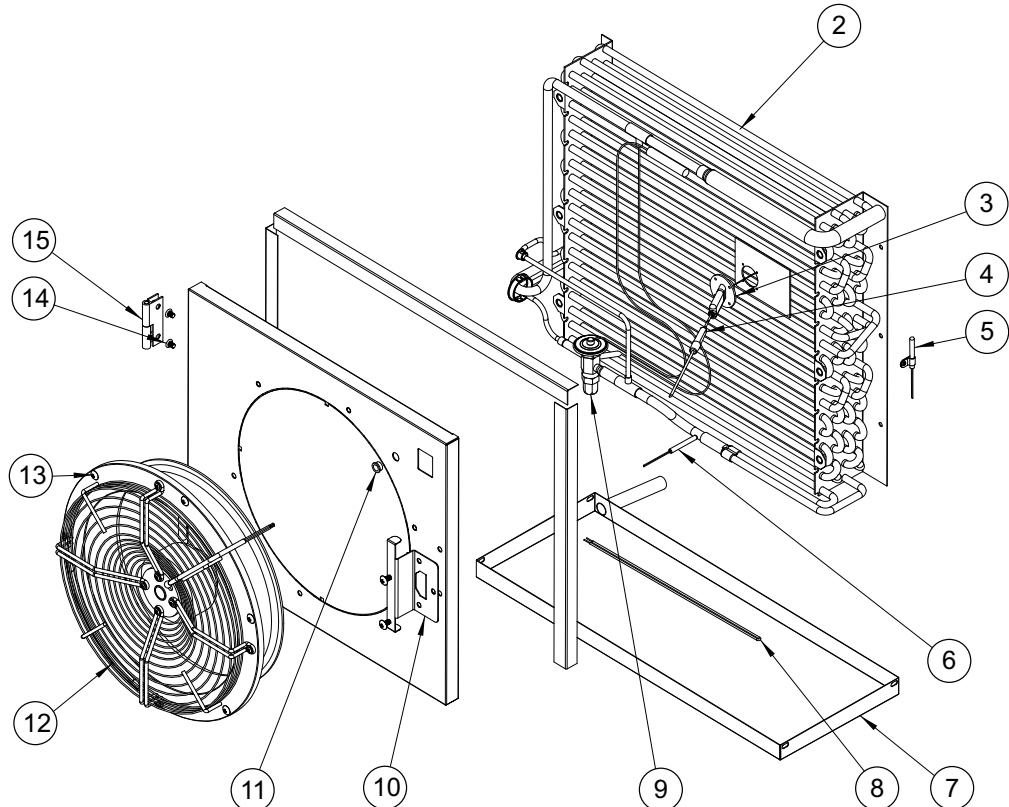

Item	Part	Description	Qty.
2	RE-29905	Coil	1
3	PR-35771	Probe Receptacle Assembly	1
4	PR-36201	Probe, Product	1
5	SN-33541	Sensor, Air	1
6	PR-37483	Coil Sensor, Defrost/Sensor	1
7	PN-29943	Drip Pan	1
8	WI-35157	Wire, 11" (279mm) Loop Drain Heater	1
9	VA-29906	Expansion Valve	1
10	LT-29940	Latch, Plate for Fan Door	1
11	BU-29937	Bushing, Nylon	1
12	FA-29945	Fan	1
13	SC-29935	Bolt, 1/4-20	19
14	SC-29936	Bolt, 1/4-20 x 3/8"	8
15	HG-29938	Hinge Assembly, 2" x 3" Lift Off Left	2

5900008_0

QC3-20 Compressor

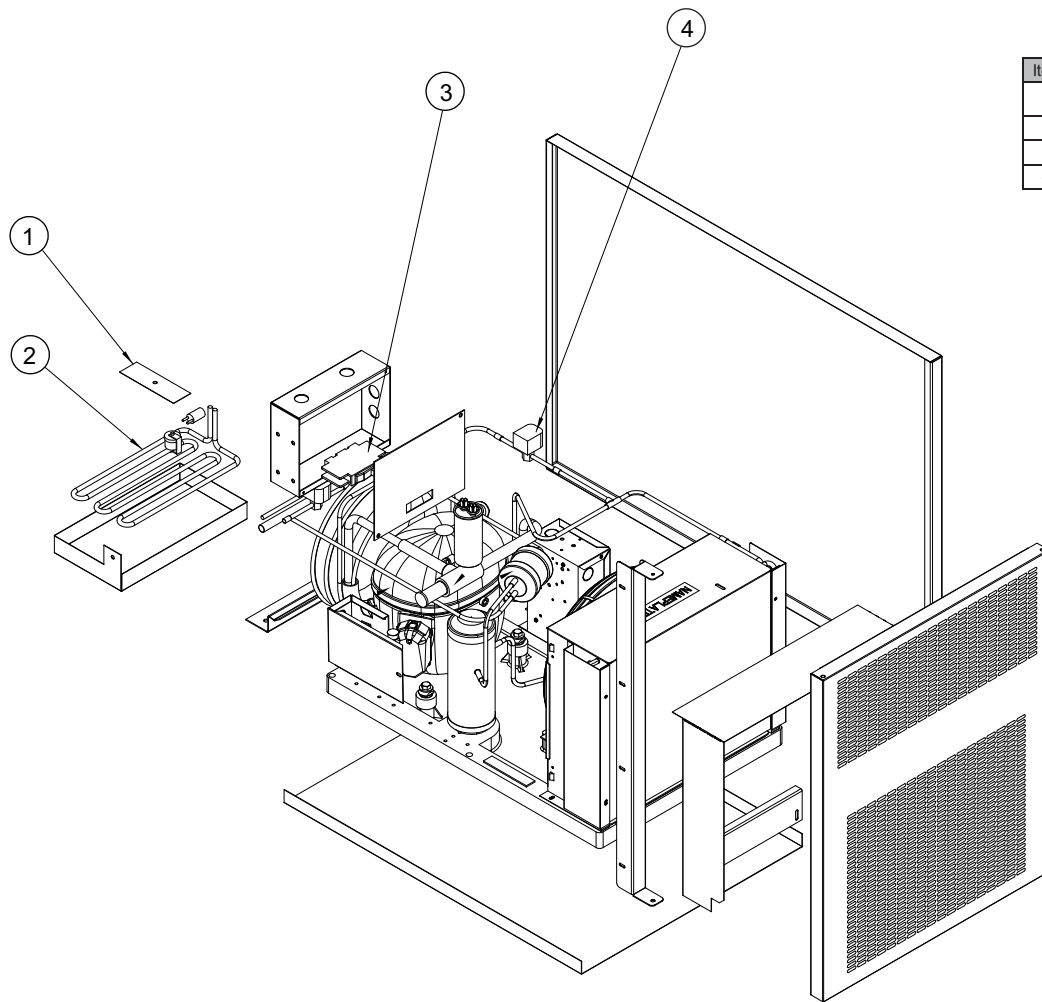

Item	Part	Description	Qty.
1	RE-29966	Condensate Evaporator Pan, includes Hold Down Bracket	1
2	EL-29828	Evaporator Element, 115V200W	1
3	FU-29965	Breaker, 1 Pole 20 Amp	1
4	VA-29863	Solenoid Valve	1

5900009_0

QC3-20 Control Panel

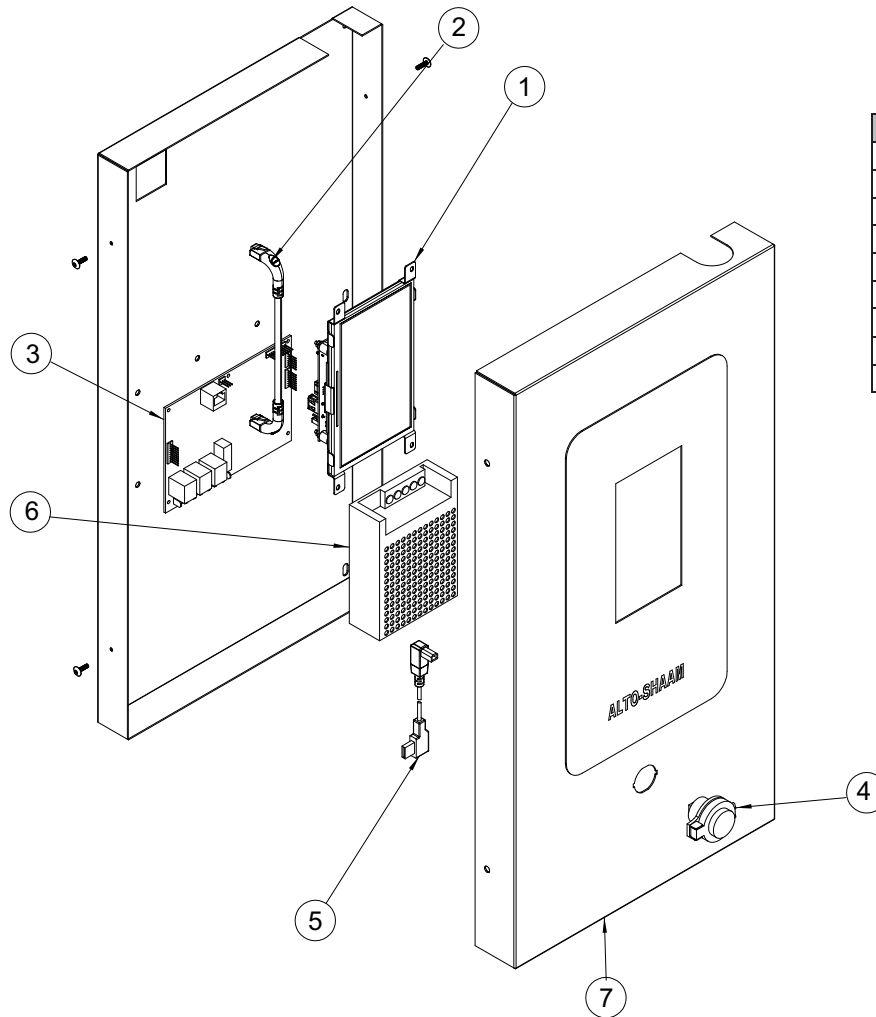

Item	Part	Description	Qty.
1	5021440	LCD Display Assembly, 7"	1
2	CB-38675	Ethernet Cable	1
3	CC-39540	Control Board and Firmware	1
4	CB-35746	Connector, USB, Panel Mount	1
5	CB-36571	USB Communication Cable	1
6	BA-29927	Board, Power Supply	1
7	PE-38362	Control Panel/Panel Overlay Assembly	1
8	5018422	Beeper Assembly (not shown)	1
9	SW-36882	Door Switch (not shown)	1

5900011_0

QC3-40 Compressor

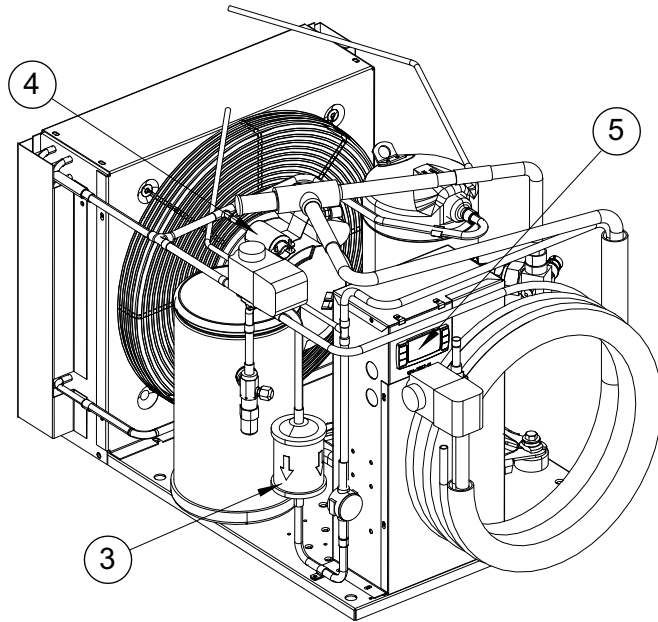

Item	Part	Description	Qty.
1	RE-35155	Coil, Solenoid, 120V,18Z7612	2
2	VA-29898	Valve,Liquid Line Solenoid	2
3	FI-37502	Filter Dryer	1
4	SW-37504	Switch, High Pressure,985-7031-01	1
5	CC-37516	Pressure Control	1

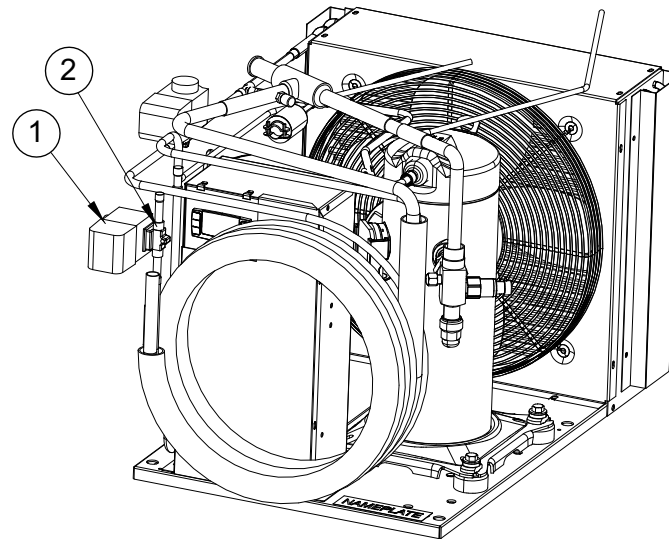

5900012_0

QC3-40 Compressor Housing

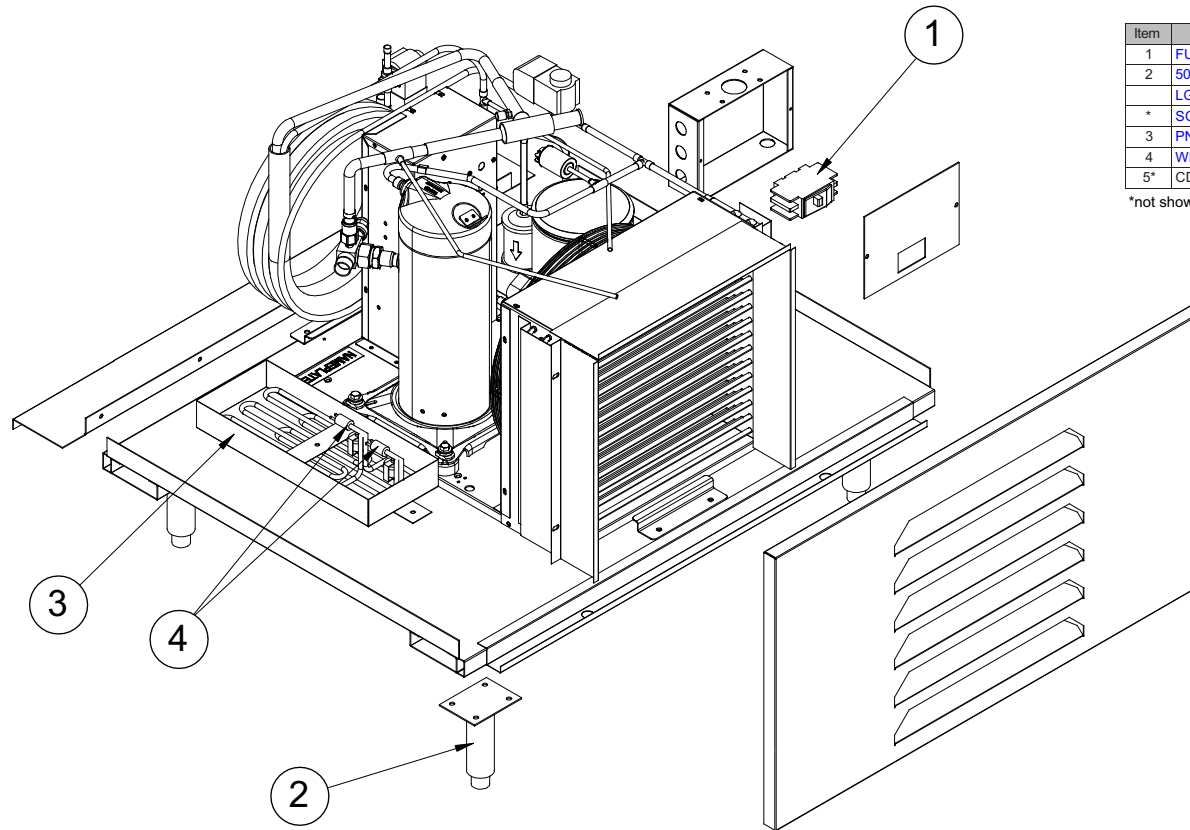

Item	Part	Description	Qty.
1	FU-29901	Breaker, 2 Pole 20 Amp, 60 Hz	1
2	5014889	Leg Assembly (Set of 4)	1
	LG-29904	Leg, 6"	4
*	SC-29824	Leg Bolt, 1/4-20 x 3.5" Shoulder Bolt Hex Head	16
3	PN-29903	Evaporator Pan, without Element	1
4	WI-35102	Evaporator Pan Heater	2
5*	CD-35103	Cord and Plug, 125/250V/20 Amp 14-20P, 9' Long	1

*not shown

5900013_0

QC3-40 Coil

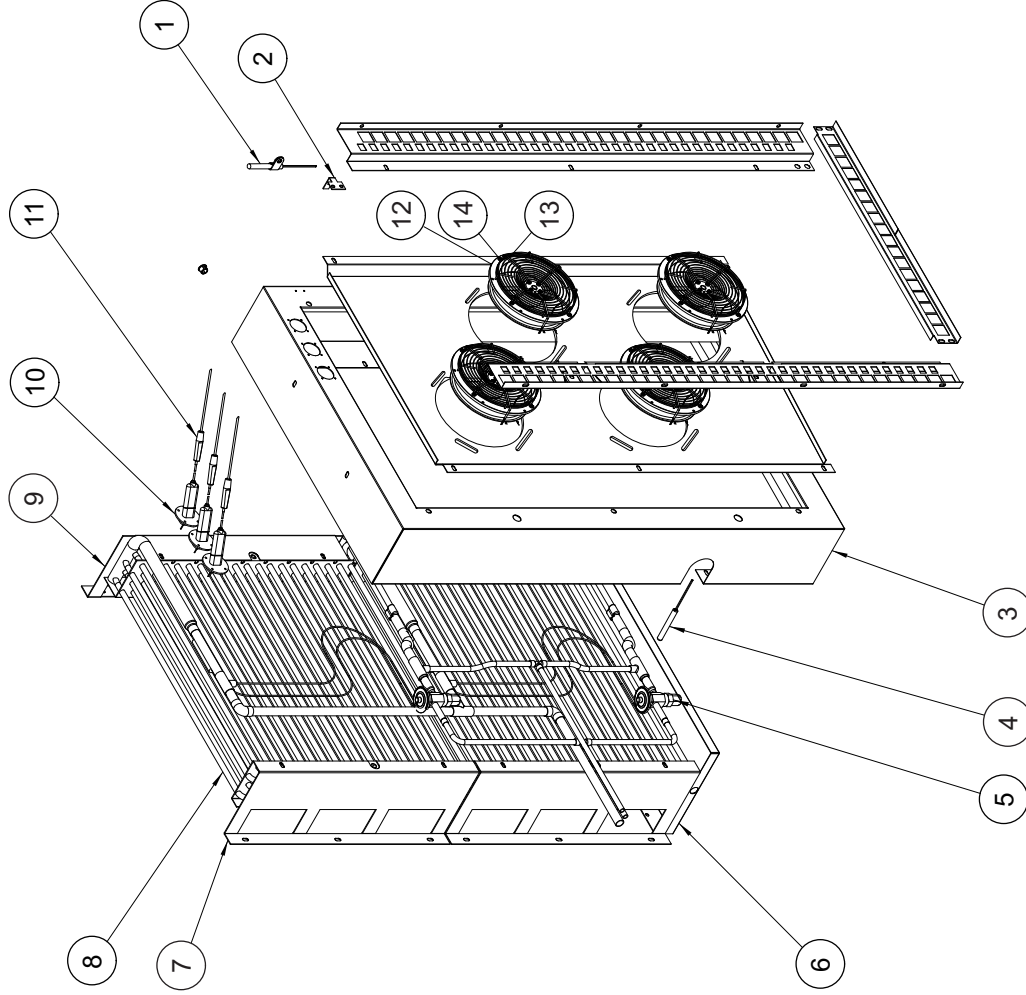

Item	Part	Description	Qty.
1	SN-33541	Air Sensor	1
2	**	Air Sensor Mounting Bracket	1
3	**	Housing, Refrigeration Enclosure	1
4	PR-37483	Coil Sensor/Defrost/Sensor	1
5	VA-29906	Valve, Expansion	2
6	PN-37583	Drain Pan, Evaporator, Right	1
7	PN-37582	Drain Pan, Evaporator, Left	1
8	CL-37751	Clip, Left, Coil	2
9	RE-29905	Evaporator Coil	2
10	CL-37752	Clip, Right, Coil	2
11	PR-35486	Probe Receptacle	3
12	PR-35770	Probe	3
13	RF FAN1901	Evaporator Fan, Axial w/Lead, 115V	4
14	HD GRD-1909	Guard, Fan, MG-18	4
15	FA BLT-0803	Bolt, M6 x 1 x 10mm Hex Head Stainless	16
	EL PLG-087	Plug, 0.875" Nylon Hole (not shown)	1

** not available from factory

5800014_1

QC3-40 Door

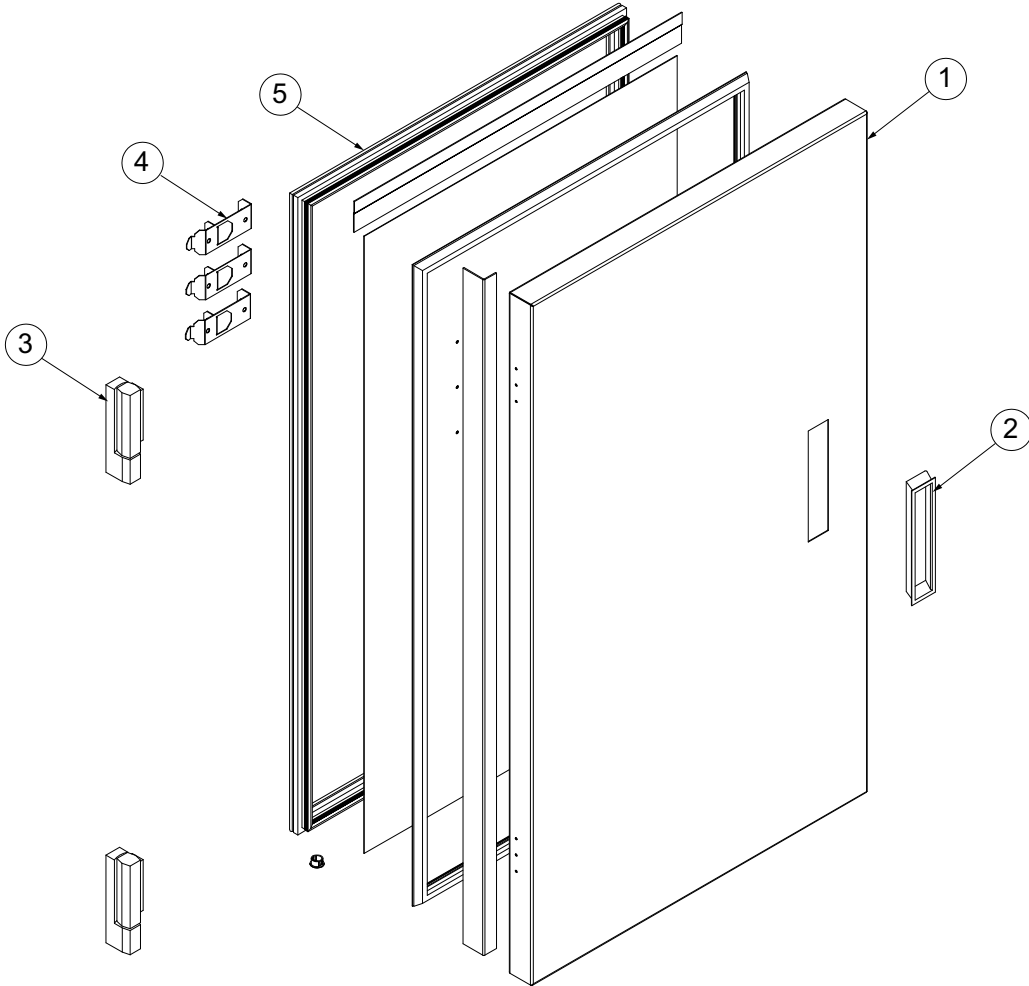

Item	Part	Description	Qty.
1	DR-36748	Door Assembly, Left-Hand	1
	Contact factory	Door Assembly, Right-Hand	1
2	HD-29958	Handle, Door	1
3	HG-36650	Hinge	1
4	HL-29840	Food Probe Holder	3
5	GS-29914	Gasket, Door	1
6	WI-29963	Mullion Heater, 211"W/17.25" 115V (not shown)	1
7	CV-35800	Service Kit, Cover, Mullion (not shown)	1

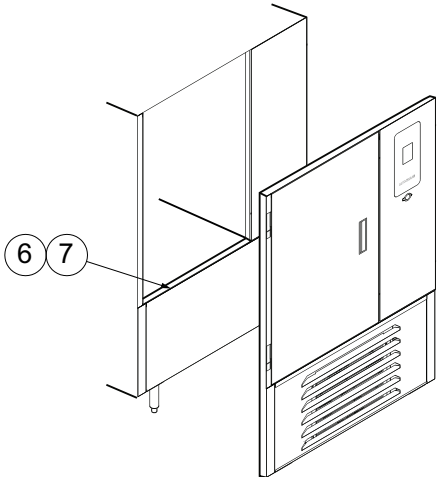

5900015_0

QC3-40 Pan Supports

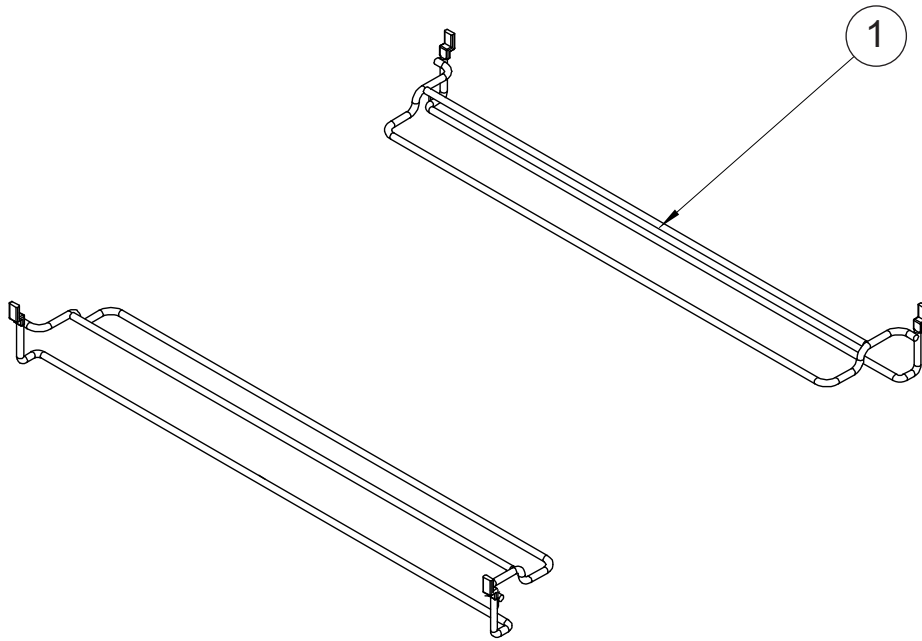

Item	Part	Description	Qty.
1	SR36881	Rack,PanSupport	18

5900016_0

QC3-40 Control Panel

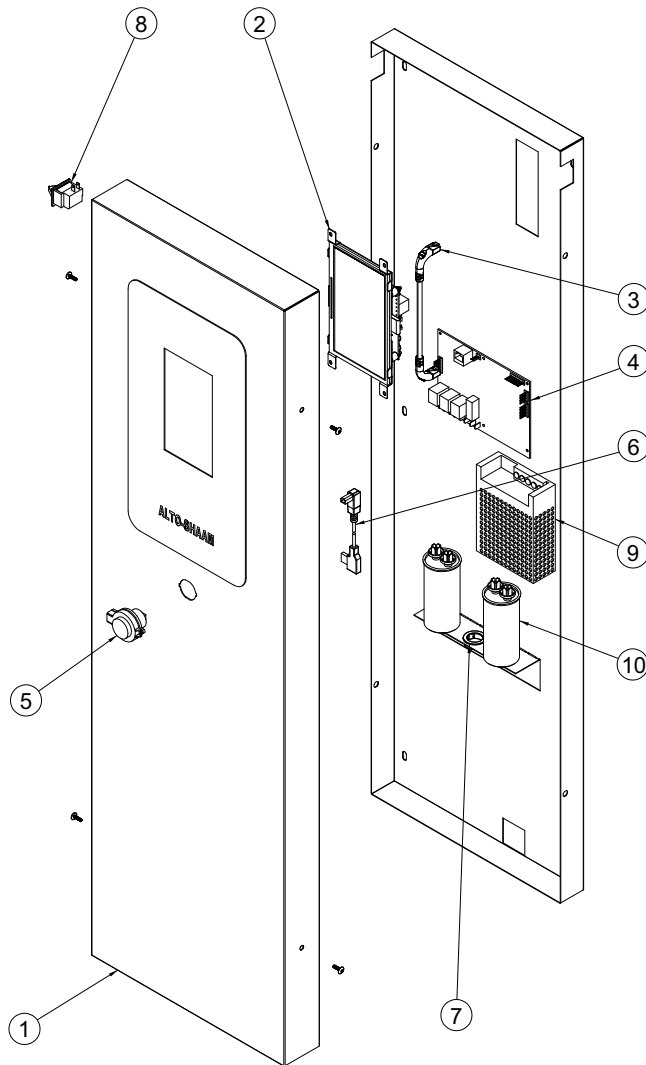

Item	Part	Description	Qty.
1	PE-38362	Control Panel/Panel Overlay Assembly	1
2	5021440	LCD Display Assembly, 7"	1
3	CB-38675	Ethernet Cable	1
4	CC-39540	Control Board and Firmware	1
5	CB-35746	Connector, USB	1
6	CB-36571	USB Communication Cable with Plug	1
7	BU-33619	Grommet, 1" Hole	1
8	SW-36882	Door Switch	1
9	BA-29927	Power Supply	1
10	CU-29964	Capacitor	2
11	5018422	Beeper Assembly (not shown)	1

5900017_0

QC3-100 Compressor

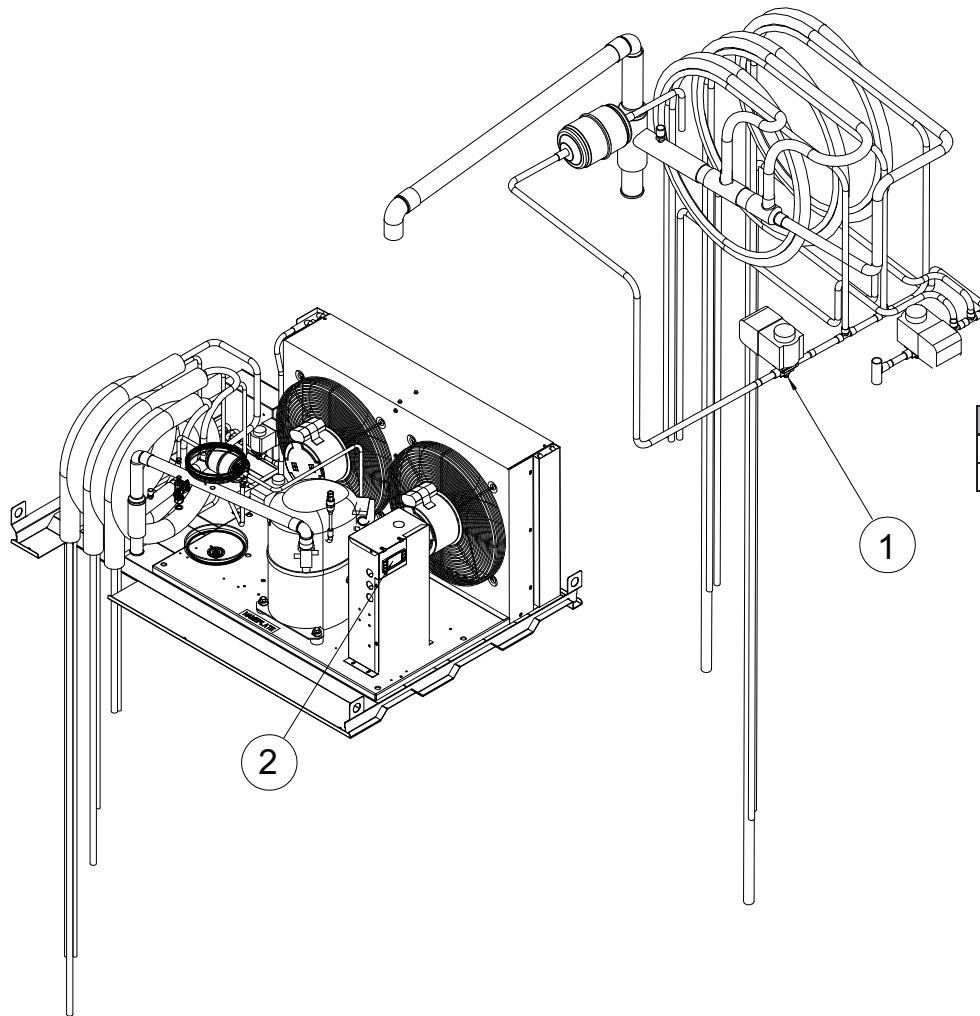

Item	Part	Description	Qty.
1	VA-29898	Valve, Liquid Line Solenoid	2
2	CC-37516	Pressure Control	1

5900018_0

QC3-100 Coil

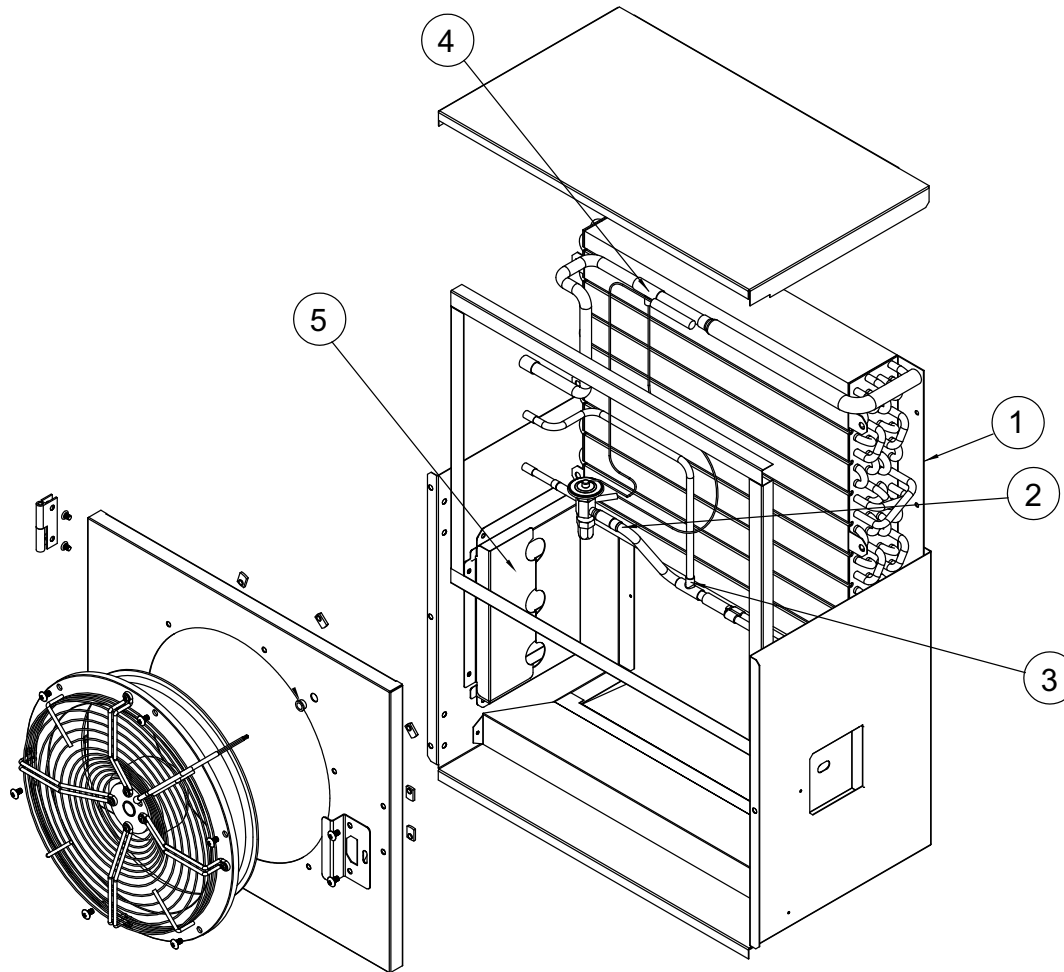

Item	Part	Description	Qty.
1	RE-29905	Coil Assembly, 19x20	3
2	VA-29906	Valve, Expansion	3
3	TE-35153	Tee, Copper, 1/2 x 1/2 x 3/8" ID	1
4	TE-29985	Tee, Copper, 1/2" x 1/2" x 1/4" ID	1
5	CV-37624	Cover	1
6*	FA-29945	Evaporator Fan Motor	3
7*	PR-37483	Coil Sensor, Defrost/Sensor	1

* not shown

5900019_0

QC3-100 Door

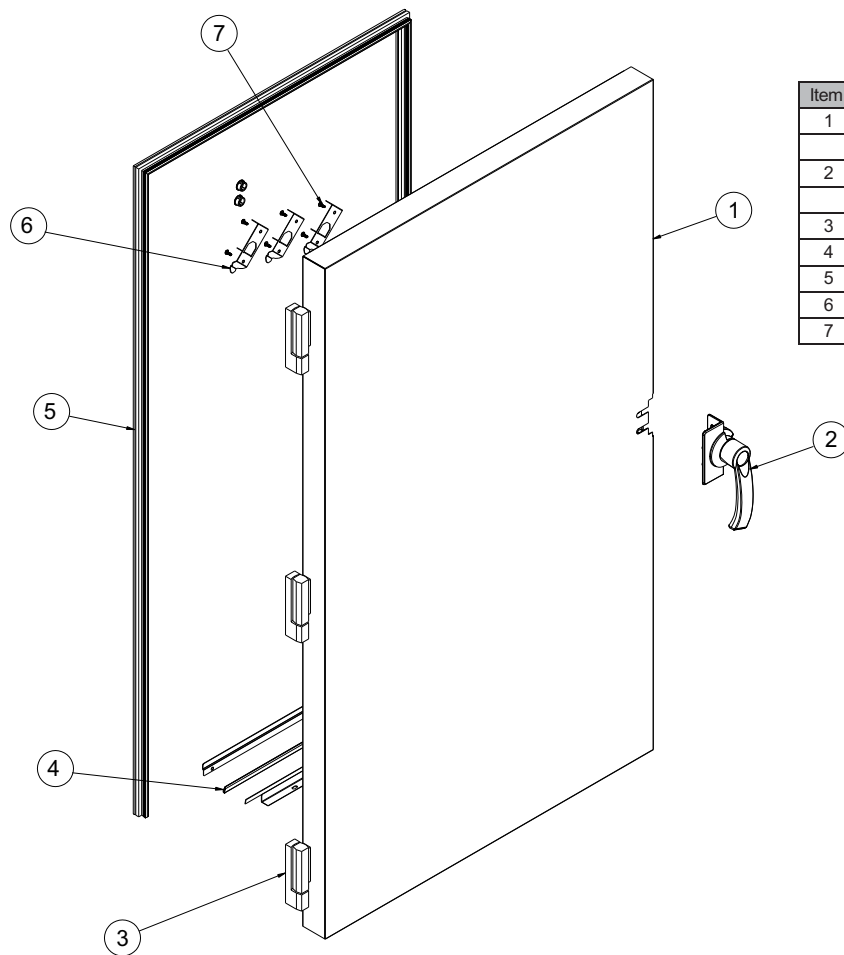

Item	Part	Description	Qty.
1	DR-29990	Door Assembly, Left-Hand	1
	Contact factory	Door Assembly, Right-Hand	1
2	HD-26967	Handle, Door, LH	1
	HD-26966	Handle, Door, RH	1
3	HG-36650	Hinge, Adjustable	3
4	GS-29994	Gasket, Compression	1
5	GS-29993	Gasket, Door	1
6	HL-29840	Food Probe Holder	3
7	SC-29991	Bolt, 8-32 X 1/2, Phillips Truss	6

5900020_0

QC3-100 Interior (LH door shown)

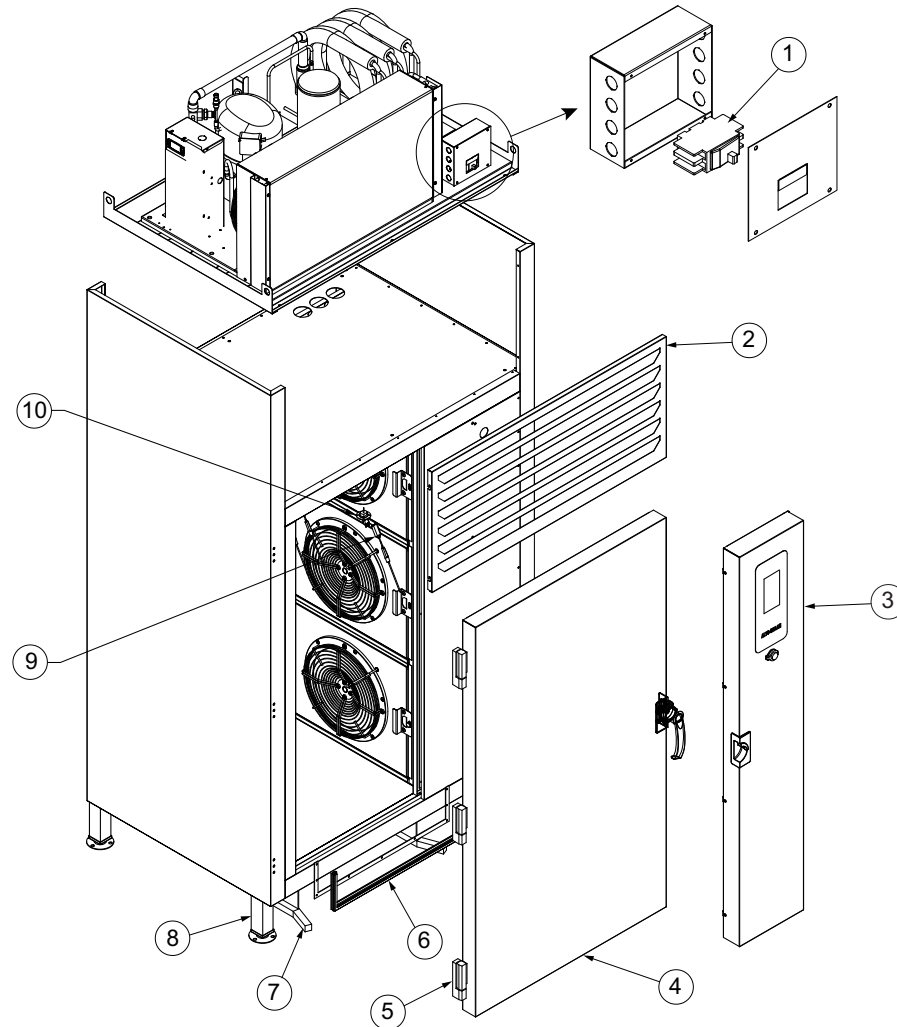

Item	Part	Description	Qty.
1	FU-29996	Breaker, 2 Pole, 30 Amp	1
2	PN-29842	Louver Panel	1
3	PN-38362	Panel, Control Panel Assembly,	1
4	DR-29990	Door Assembly, Left-Hand	1
	Contact factory	Door Assembly, Right-Hand	1
5	HG-36650	Hinge, Adjustable	3
6	GS-35308	Gasket, Compression	1
7	Contact factory	Trolley Guides	1
8	5016746	Leg Assembly (Set of 4) - Not factory installed	1
9	PR-35487	Probe, QR 1600MM	3
10	PR-35486	Probe, Receptacle	3

5900021_0

QC3-100/NT Narrow Trolley (LH door shown)

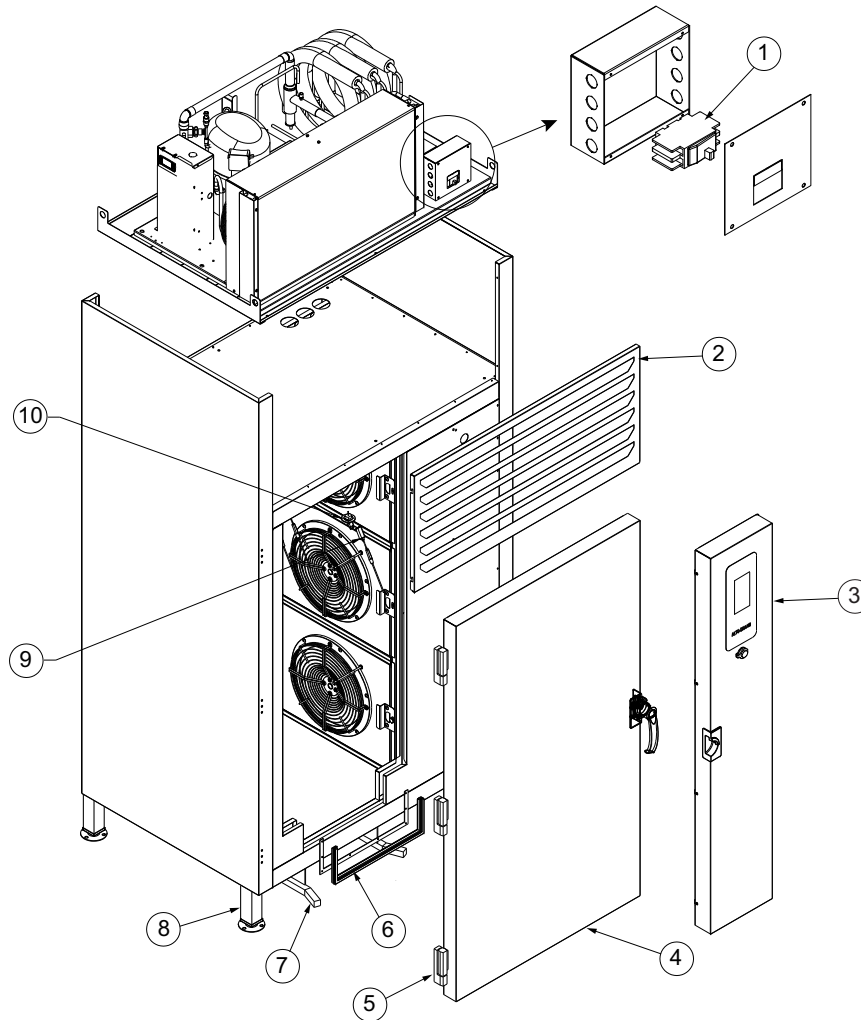

Item	Part	Description	Qty.
1	FU - 29996	Breaker, 2 Pole, 30 Amp	1
2	PN - 29842	Louver Panel	1
3	PE - 38362	Panel, Control Panel Assembly	1
4	DR - 37463	Door Assembly, Narrow Trolley, Left-Hand	1
	DR - 37464	Door Assembly, Narrow Trolley, Right-Hand	1
5	HG - 36650	Hinge, Adjustable	3
6	GS - 37461	Gasket, Lower Trolley	1
7	Contact factory	Trolley Guides (Set of 2)	1
8	5016746	Leg Assembly (Set of 4) - Not factory installed	1
9	PR - 35487	Probe, QR 1600MM	3
10	PR - 35486	Probe, Receptacle	3

5900022_0

QC3-100 Control Panel (LH shown)

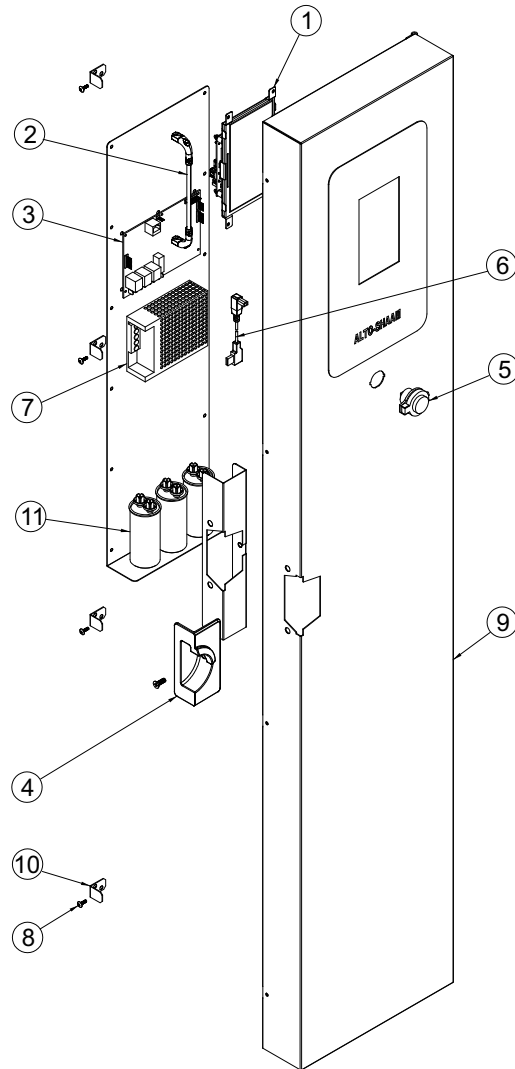

Item	Part	Description	Qty.
1	5021440	LCD Display Assembly, 7"	1
2	CB-38675	Ethernet Cable	1
3	CC-39540	Control Board and Firmware	1
4	LT-26968	Door Latch, Left-Hand	1
	LT-26969	Door Latch, Right-Hand	1
5	CB-35746	Connector, USB, Panel Mount	1
6	CB-36571	USB Communication Cable	1
7	BA-29927	Power Supply, 115V-12VDC,40 W,60C OP Temp	1
8	SC-29632	Bolt, 1/4-20 x 3.5" Shoulder Bolt Hex Head	1
9	PE-38362	Control Panel Assembly	1
10	PN-35934	Bracket, Mounting	1
11	CU-29964	Capacitor, 14MFD,440VAC	1
12	5018422	Beeper Assembly (not shown)	1

5900023_0

ALTO-SHAAM.

Menomonee Falls, WI U.S.A.

Phone 800-558-8744 | +1-262-251-3800 | alto-shaam.com