

PROCESSING FREEZER/CHILLER/REFRIGERATION SYSTEM

Model:

QC-3

QC-20

QC-40

QC-50

QC-50 REMOTE

QC-100

QC-100 REMOTE

QC-100



QC-40



QC-20



• **INSTALLATION**

• **OPERATION**

• **MAINTENANCE**



W164 N9221 Water Street • P.O. Box 450 • Menomonee Falls, Wisconsin 53052-0450 USA
PHONE: 262.251.3800 • 800.558.8744 USA/CANADA FAX: 262.251.7067 • 800.329.8744 U.S.A. ONLY
www.alto-shaam.com

ALTO-SHAAM®

Delivery	1
Unpacking	1
Safety Procedures and Precautions.....	2

Installation

Site Installation	3
Clearance Requirements.....	3
Installation Requirements.....	4
Water Drainage.....	4
Trolley Guide Installation.....	5
Dimension Drawings, weights & capacities.....	6-10
Options and Accessories.....	11
Electrical Specifications	12

Operation

Operating Introduction.....	13
Chill Processing Cycles.....	14
Quickchiller Operation Modes	14
Initial Quickchiller Operation	14
Additional Information	15
Control Panel Identification	16
Basic Operation	17
Advanced Operation - Hold Temp	18
Advanced Operation - Chill Modes.....	19
Factory Default Set Points	19
Advanced Operation - Programming	20
Advanced Operation - User Settings	21
Food Probe Use.....	22
Time & Temperature Guidelines.....	22
Automatic Defrost.....	22
Food Handling Guidelines	23
Product Covering	23
Portioning & Packaging.....	23
Quickchiller Pan Capacity	24
Product Capacity Per Pan.....	24
Portion Sizes and Pan Capacities	25

Care and Cleaning

Cleaning and Preventative Maintenance	26
Protecting Stainless Steel Surfaces.....	26
Cleaning Agents.....	26
Cleaning Materials	26
Interior Cleaning.....	27
Exterior Cleaning	27
Probe Cleaning Procedures	27
Food Trolley Cleaning.....	27
Monthly Compressor & Condenser Maintenance	27

Service

Control Error Displays.....	28
<u>Service Views</u>	
QC-3 Control	29
QC-3 Coil	30
QC-20 Control	31
QC-20 Coil	32
QC-20 Condenser	33
QC-40	34
QC-40 Control	35
QC-50, QC-100 Control	36
QC-100 Coil	37
QC-50, QC-100 Breaker	38
QC-50, QC-100 Fan	38
QC-50 Remote	39
QC-50, QC-100 Remote Condenser Connection.....	40

Wire Diagrams

Always refer to the wire diagram(s) included with the unit for most current version.

Warranty

Transportation Damage and Claims	Back Cover
Limited Warranty	Back Cover

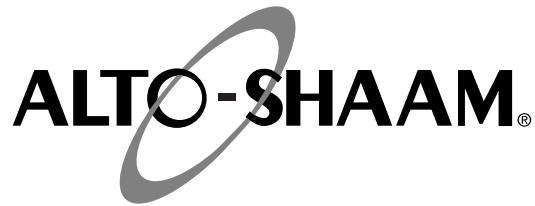

DELIVERY

This Alto-Shaam appliance has been thoroughly tested and inspected to insure only the highest quality unit is provided. Upon receipt, check for any possible shipping damage and report it at once to the delivering carrier. *See Transportation Damage and Claims section located in this manual.*

This appliance, complete with unattached items and accessories, may have been delivered in one or more packages. Check to ensure that all standard items and options have been received with each model as ordered.

Save all the information and instructions packed with the appliance. Complete and return the warranty card to the factory as soon as possible to assure prompt service in the event of a warranty parts and labor claim.

This manual must be read and understood by all people using or installing the equipment model. Contact the Alto-Shaam service department if you have any questions concerning installation, operation, or maintenance.

NOTE: All claims for warranty must include the full model number and serial number of the unit.

UNPACKING

1. Carefully remove the appliance from the carton or crate.

NOTE: Do not discard the carton and other packaging material until you have inspected the unit for hidden damage and tested it for proper operation.

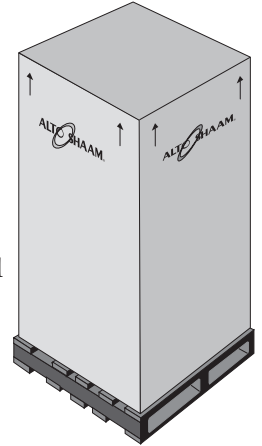

2. Read all instructions in this manual carefully before initiating the installation of this appliance.

DO NOT DISCARD THIS MANUAL.

This manual is considered to be part of the appliance and is to be provided to the owner or manager of the business or to the person responsible for training operators. *Additional manuals are available from the Alto-Shaam service department.*

3. Remove all protective plastic film, packaging materials, and accessories from the appliance before connecting electrical power. Store any accessories in a convenient place for future use.



SAFETY PROCEDURES AND PRECAUTIONS

Knowledge of proper procedures is essential to the safe operation of electrically and/or gas energized equipment. In accordance with generally accepted product safety labeling guidelines for potential hazards, the following signal words and symbols may be used throughout this manual.

DANGER	
	Used to indicate the presence of a hazard that WILL cause severe personal injury, death, or substantial property damage if the warning included with this symbol is ignored.

WARNING	
	Used to indicate the presence of a hazard that CAN cause personal injury, possible death, or major property damage if the warning included with this symbol is ignored.

CAUTION	
	Used to indicate the presence of a hazard that can or will cause minor or moderate personal injury or property damage if the warning included with this symbol is ignored.

CAUTION	
Used to indicate the presence of a hazard that can or will cause minor personal injury, property damage, or a potential unsafe practice if the warning included with this symbol is ignored.	

NOTE: Used to notify personnel of installation, operation, or maintenance information that is important but not hazard related.

1. This appliance is intended to chill or freeze foods for the purpose of human consumption. No other use for this appliance is authorized or recommended.
2. This appliance is intended for use in commercial establishments where all operators are familiar with the purpose, limitations, and associated hazards of this appliance. Operating instructions and warnings must be read and understood by all operators and users.
3. Any troubleshooting guides, component views, and parts lists included in this manual are for general reference only and are intended for use by qualified technical personnel.
4. This manual should be considered a permanent part of this appliance. This manual and all supplied instructions, diagrams, schematics, parts lists, notices, and labels must remain with the appliance if the item is sold or moved to another location.

NOTE	
	For equipment delivered for use in any location regulated by the following directive: DO NOT DISPOSE OF ELECTRICAL OR ELECTRONIC EQUIPMENT WITH OTHER MUNICIPAL WASTE.

INSTALLATION

DANGER



IMPROPER INSTALLATION, ALTERATION, ADJUSTMENT, SERVICE, OR MAINTENANCE COULD RESULT IN SEVERE INJURY, DEATH, OR CAUSE PROPERTY DAMAGE.

READ THE INSTALLATION, OPERATING AND MAINTENANCE INSTRUCTIONS THOROUGHLY BEFORE INSTALLING OR SERVICING THIS EQUIPMENT.

CAUTION



TO PREVENT PERSONAL INJURY, USE CAUTION WHEN MOVING OR LEVELING THIS APPLIANCE.

SITE INSTALLATION

Position the Quickchiller to allow sufficient air ventilation through the condensing unit(s). The rear of unit should be no closer than 6" (152mm) to any wall or structure.

Avoid installing the chiller immediately adjacent to fryers, charbroilers, or any other equipment producing grease laden air; heat producing equipment such as ovens and ranges; and steam discharging equipment such as steamer ovens and kettles. Do not locate the Quickchiller in direct sunlight.

Allow sufficient front clearance for serviceability and for easy maneuvering of food trolleys in and out of the cabinet.

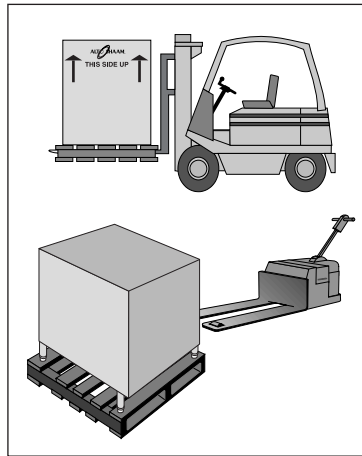

CLEARANCE REQUIREMENTS

BACK: 6" (152mm) TOP: 6" (152mm)
SIDES: 4" (102mm) minimum at both sides.
18" (457mm) MINIMUM CLEARANCE
FROM HEAT PRODUCING EQUIPMENT.

INSTALLATION REQUIREMENTS

Unit must NOT be tipped on its side at any time.

Tipping will cause damage to the unit and void the warranty.

- One (1) Floor Drain: 1/2" (12,7mm) diameter
- Appliance must be installed level.
- The appliance must not be installed in any area where it may be affected by steam, grease, dripping water, extreme temperatures, or any other severely adverse conditions.

In order to maintain standards established by the National Sanitation Foundation, all counter mounted equipment must be sealed to the counter with a NSF listed silicone sealant.

INSTALLATION

Prior to moving the Quickchiller to the installation site, check the dimensions of doors, passageways, and ceiling heights in the areas through which the cabinet must be moved. Also check the turning radius if the cabinet must be moved around an existing structure. The use of a fork lift or pallet lift truck is required for moving and leveling most Quickchiller models.

NOTE: In certain instances, it may be necessary to remove doors and door hardware to negotiate tight spaces.



**5-Year Limited
Warranty on
self-contained
compressor**

Effective from date of
shipment. (EXCLUDES LABOR)



**SANITATION
CLASSIFIED
UL
CLASSIFIED TO
NSF 7**

INSTALLATION

SITE INSTALLATION

INSTALLATION REQUIREMENTS

The model QC-3 is a counter mounted unit and must be sealed to the counter with a NSF listed silicone sealant.

For all other models, install the appliance on a smooth and level floor surface. Use the adjustable cabinet legs to level the Quickchiller.

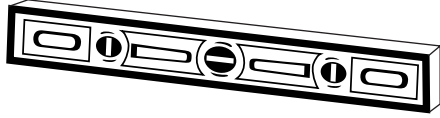

Adjust from front-to-back and from side-to-side with the use of a spirit level to evenly distribute the cabinet weight and avoid pulling the cabinet alignment out of square.

After leveling the cabinet of cart equipped models, check the height relationship of the roll-in cart to the cabinet. Adjust the Quickchiller height as needed to accommodate the cart and to securely close the Quickchiller door(s).

DOOR SEAL:

Check the door gasket to make certain it is sealing properly and that the gasket provides an even and positive seal around the entire door frame.

CAUTION



**TO PREVENT PERSONAL INJURY,
USE CAUTION WHEN MOVING OR
LEVELING THIS APPLIANCE.**

WATER DRAINAGE

DRAINAGE:		
QC-3	QC-20	QC-40
EVAPORATOR PANS: NO INSTALLATION REQUIRED		
QC-50	QC-100	
ONE (1) FLOOR DRAIN: 1/2" (12,7mm) DIAMETER		

A 1/2" I.D. (12,7mm) PVC pipe is furnished with each QC-50 and QC-100 model. Use PVC glue to attach the pipe into the drain opening at the rear of the unit. Insert the PVC pipe into the drain opening with a 1/4" (6mm) clockwise turn. Connect the PVC pipe to discharge through an indirect waste pipe into an open-site drain by means of a 2" (51mm) air gap. Connection must be within 10' (3m) of the unit.

NOTE: In the U.S.A., this equipment is to be installed to comply with the Basic Plumbing Code of the Building Officials and Code Administrators International, Inc. [BOCA], and the Food Service Sanitation Manual of the Food & Drug Administration [FDA].

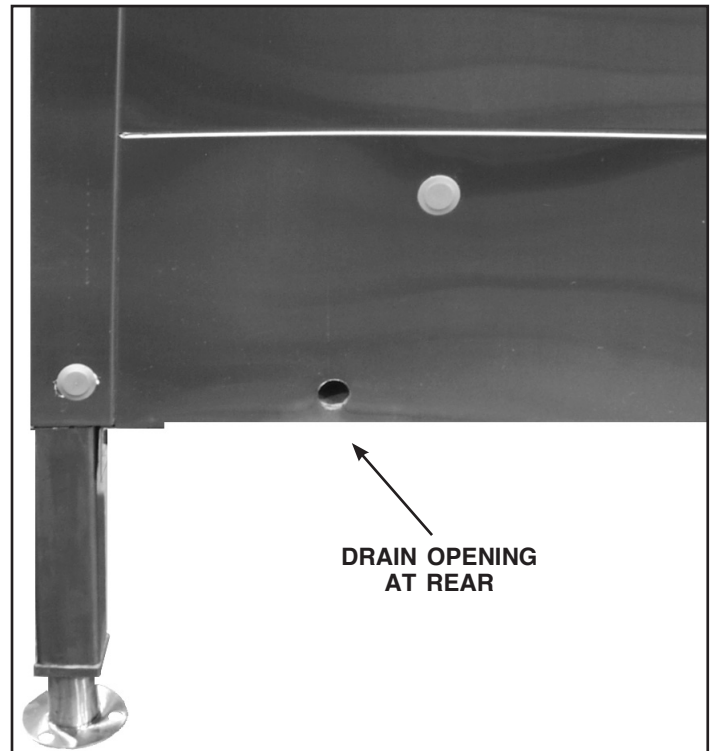

INSTALLATION

SITE INSTALLATION

TROLLEY GUIDE INSTALLATION

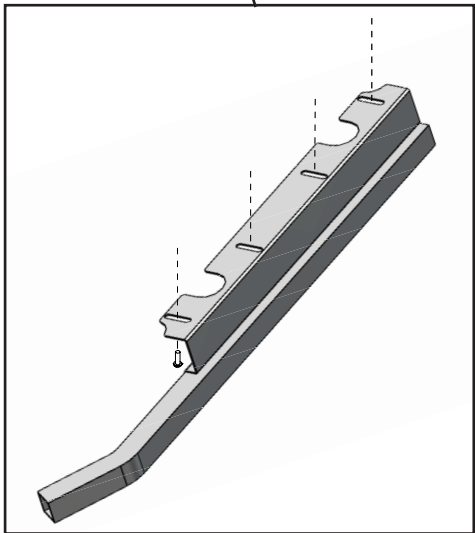
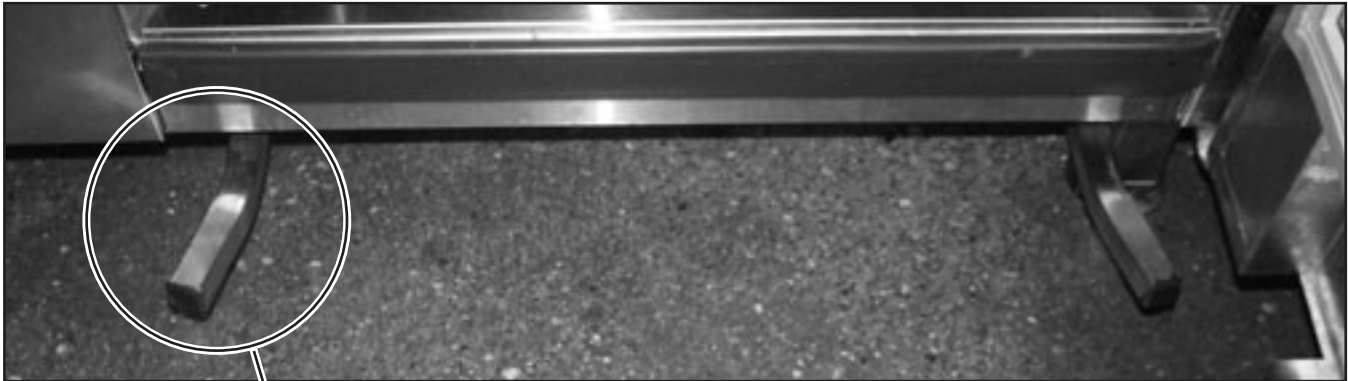

Trolley Guide Installation

1. Align each guide rail with the holes located under the cabinet.
2. Loosely fasten each guide rail with a washer, lock washer and bolt.
3. Push the roll-in cart (trolley) into the Quickchiller, center the cart right-to-left, and close the door.
4. Slide both guide rails toward the center of the Quickchiller until they make contact with the roll-in cart. Lock the guide rails into position by tightening the bolts. At the front of the Quickchiller, make certain contact has been made between the Quickchiller and the cart along the total width of the door to create a complete seal. When a full seal has been determined, recheck each connection to make certain it has been fully tightened.

INSTALLATION

SITE INSTALLATION

QC-3

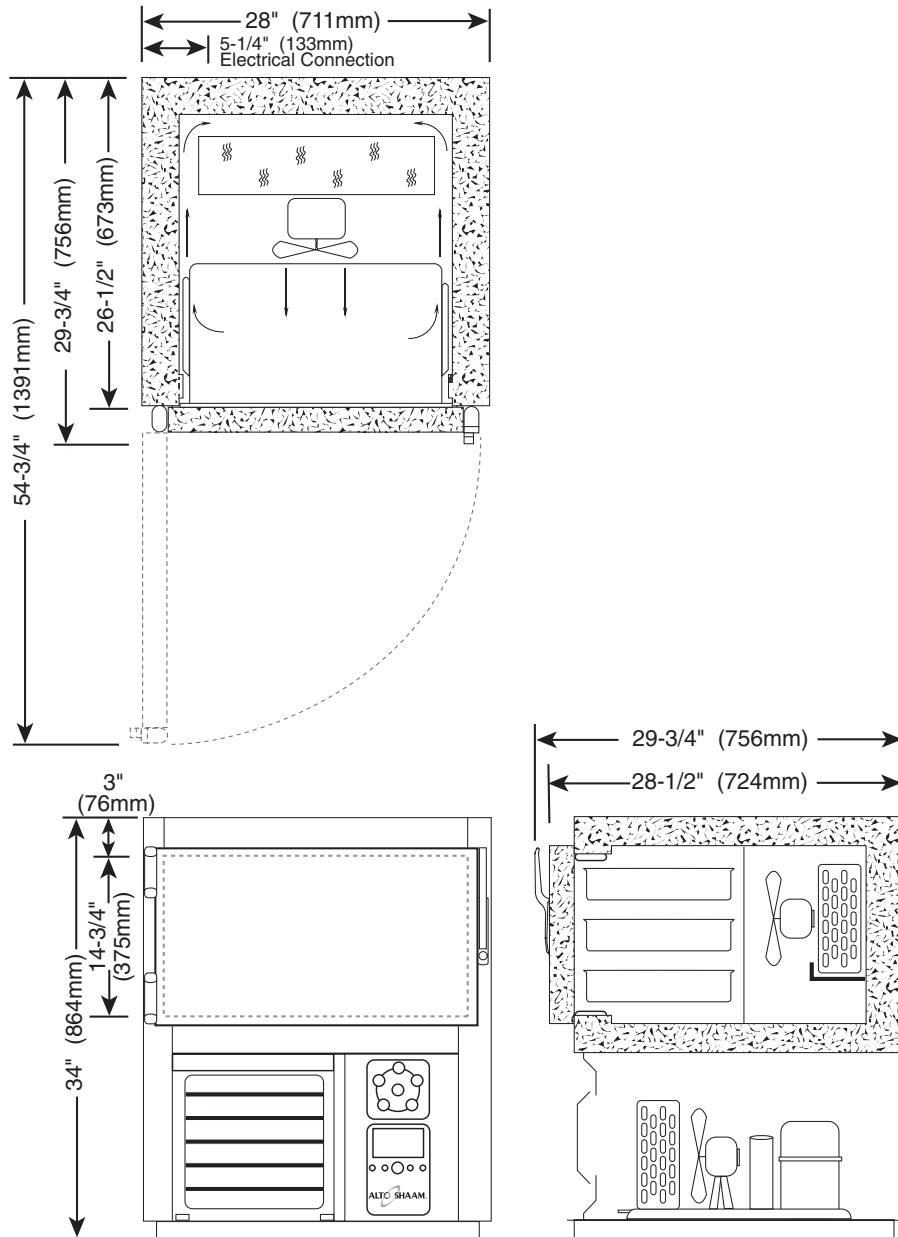

WEIGHT

NET: 350 lb (159 kg) SHIP: 405 lb (184 kg)

CARTON DIMENSIONS: (L x W x H)
40" x 34" x 43"
(1016mm x 864mm x 1092mm)

REFRIGERATION

R404a Refrigerant

One (1) 3/4 hp Condensing Unit:
3,810 BTU's per hour at -5°F (-21°C) in the freeze mode
7,260 BTU's per hour at +20°F (-7°C) in the chill mode

PRODUCT \ PAN CAPACITY

Approximately 36 lb (16 kg) MAXIMUM

VOLUME MAXIMUM: 22-1/2 QUARTS (28,5 LITERS)

FULL-SIZE PANS: GASTRONORM 1/1:
Three (3) 20" x 12" x 2-1/2" (530 x 325 x 65mm)

CAPACITY FOR UP TO THREE (3) OPTIONAL STAINLESS STEEL WIRE SHELVES

INSTALLATION

SITE INSTALLATION

QC-20

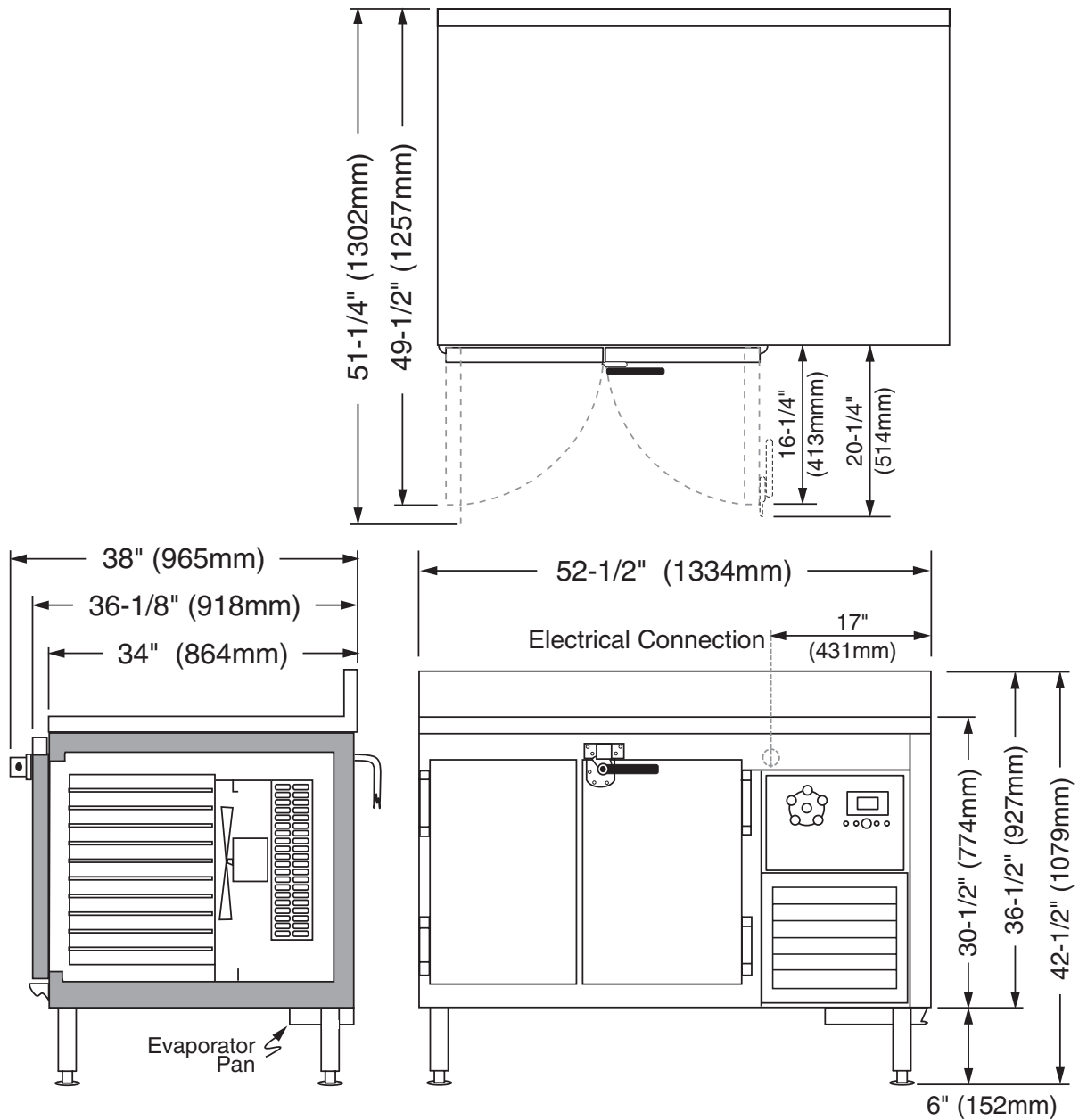

WEIGHT	
NET: 601 lb (273 kg)	SHIP: 665 lb (302 kg)
CARTON DIMENSIONS: (L x W x H) 64" x 45" x 45" (1626mm x 1143mm x 1143mm)	
REFRIGERATION	
R404a Refrigerant	
One (1) 1 hp Condensing Unit:	
FREEZE MODE: 4,790 BTU's per hour at -5°F (-21°C)	
CHILL MODE: 8,600 BTU's per hour at +20°F (-7°C)	

PRODUCT \ PAN CAPACITY	
MAXIMUM CHILLING CAPACITY: Approximately 72 lb (33 kg)	
VOLUME MAXIMUM: 45 QUARTS (42,6 LITERS)	
FULL-SIZE PANS ON WIRE SHELVES: GASTRONORM 1/1:	
Five (5)	20" x 12" x 2-1/2" (530 x 325 x 65mm)
FULL-SIZE SHEET PANS:	
Ten (10)*	18" x 26" x 1"
CAPACITY FOR UP TO FOUR (4) ADDITIONAL STAINLESS STEEL WIRE SHELVES AS AN OPTION	

INSTALLATION

SITE INSTALLATION

QC-40

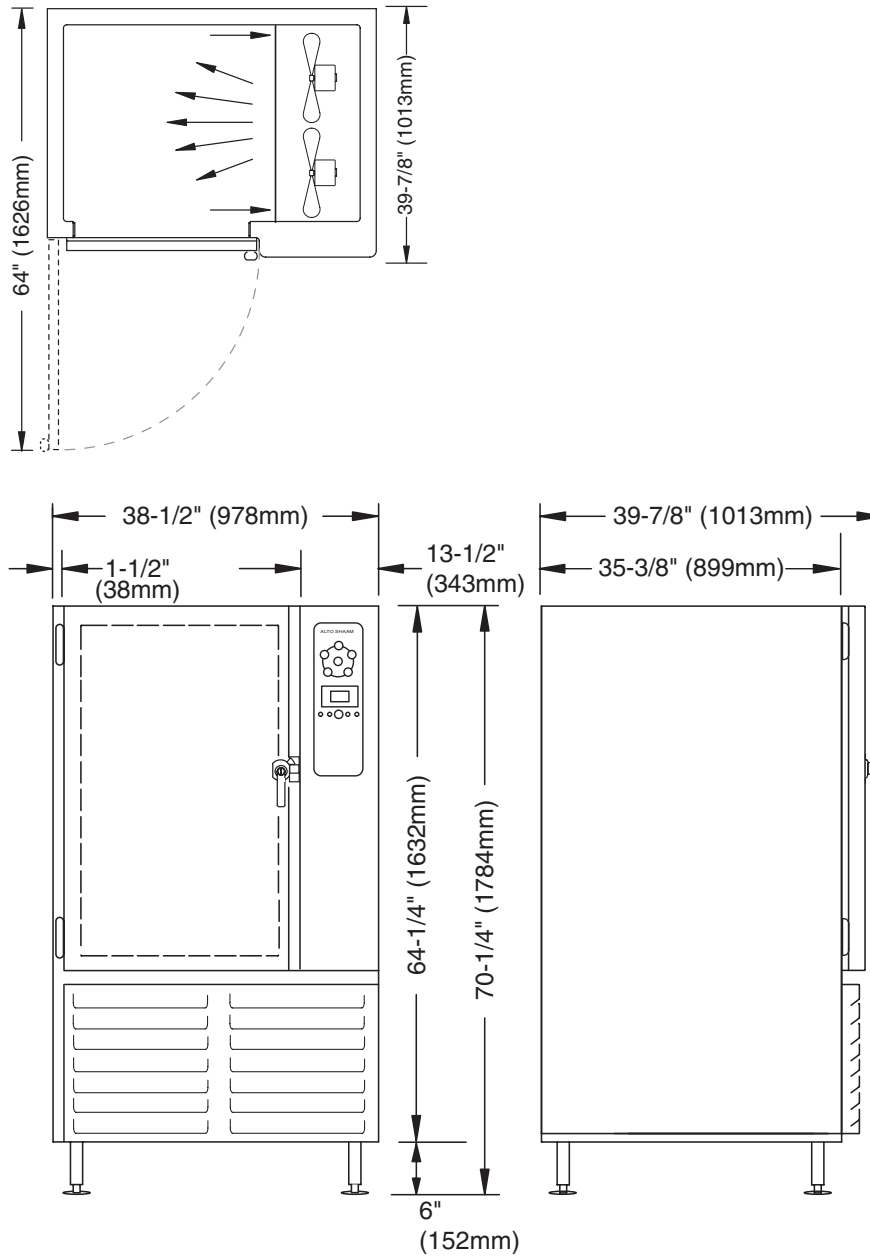

WEIGHT	
NET: 676 lb (307 kg)	SHIP: 977 lb (443 kg)
CARTON DIMENSIONS: (L x W x H)	
44" x 47" x 79"	
(1118mm x 1194mm x 2007mm)	

REFRIGERATION
R-404a Refrigerant
One (1) 1-1/2 hp Condensing Unit:
FREEZE MODE: 7,200 BTU's per hour at -5°F (-21°C)
CHILL MODE: 11,400 BTU's per hour at +20°F (-7°C)

PRODUCT/PAN CAPACITY	
Approximately 144 lb (65 kg) MAXIMUM	
VOLUME MAXIMUM: 90 QUARTS (85 LITERS)	
FULL-SIZE PANS:	GASTRONORM 1/1:
Twelve (12) 20" x 12" x 2-1/2"	(530 x 325 x 65mm)
FULL-SIZE SHEET PANS:	
Six (6)*	18" x 26" x 1" on wire shelves only
*ADDITIONAL SHELVES REQUIRED	

INSTALLATION

SITE INSTALLATION

QC-50

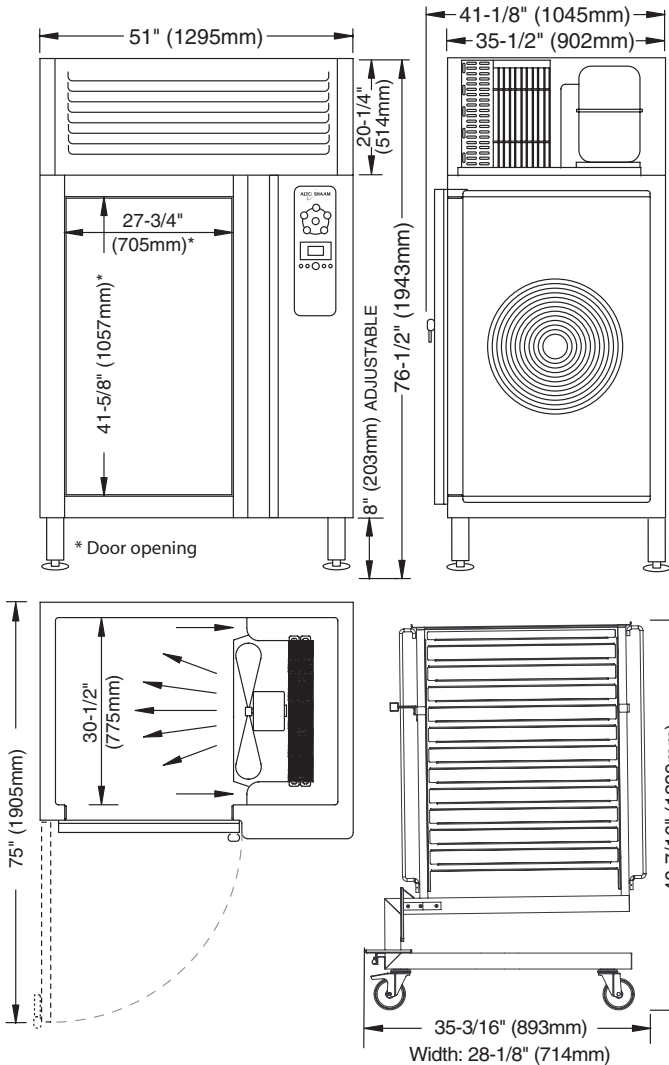

QC-50 Remote

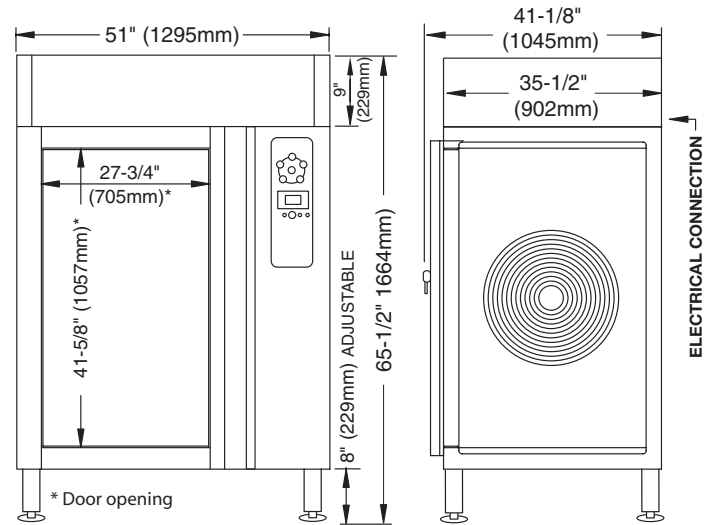

WEIGHT

	CABINET	REMOTE CONDENSER	ROLL-IN PAN CART
NET	557 lb (253 kg)	202 lb (92 kg)	120 lb (54 kg)
SHIPPING	862 lb (391 kg)	302 lb (137 kg)	150 lb (68 kg)
CRATED DIMENSIONS: (L x W x H)			
48" x 55-1/4" x 70-1/4" (1219mm x 1397mm x 1778mm)			

WEIGHT (APPROXIMATE)

	CABINET	ROLL-IN PAN CART
NET	590 lb (268 kg)	120 lb (54 kg)
SHIPPING	900 lb (408 kg)	150 lb (68 kg)
CRATED DIMENSIONS: (L x W x H)		
48" x 55-1/4" x 79-1/2" (1219mm x 1403mm x 2248mm)		

REFRIGERATION

R404a Refrigerant

One (1) 2-1/4 hp Compressor:

FREEZE MODE: 9,030 BTU's per hour at -5°F (-21°C)

CHILL MODE: 17,500 BTU's per hour at +20°F (-7°C)

PRODUCT/PAN CAPACITY

MAXIMUM PRODUCT CAPACITY -
288 lb (131 kg), 180 quarts (228 liters)

MAXIMUM CHILLING CAPACITY -
Approximately 144 lb (65 kg), 90 qts (114 liters)

FULL-SIZE PANS: GASTRONORM 1/1:
Twenty-four (24) 20" x 12" x 2-1/2" (530 x 325 x 65mm)

FULL-SIZE SHEET PANS:

Twelve (12)* 18" x 26" x 1"

*ON WIRE SHELVES ONLY. EXTRA OPTIONAL WIRE SHELVES REQUIRED FOR MAXIMUM CAPACITY SHOWN ABOVE.

INSTALLATION

SITE INSTALLATION

QC-100

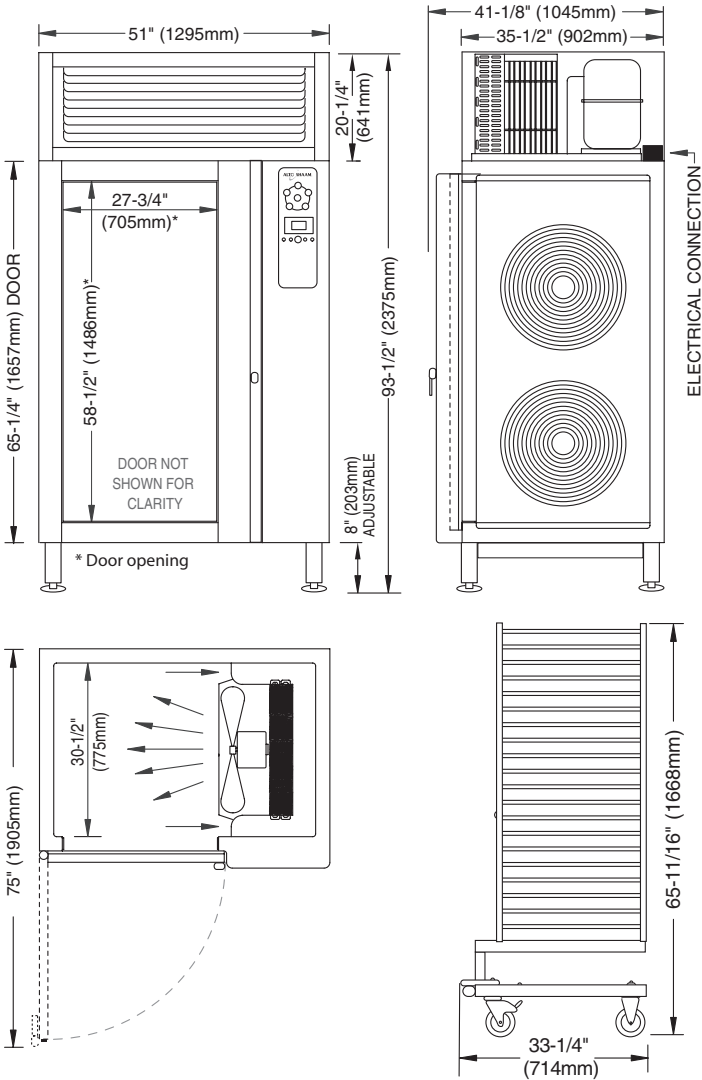

QC-100 Remote

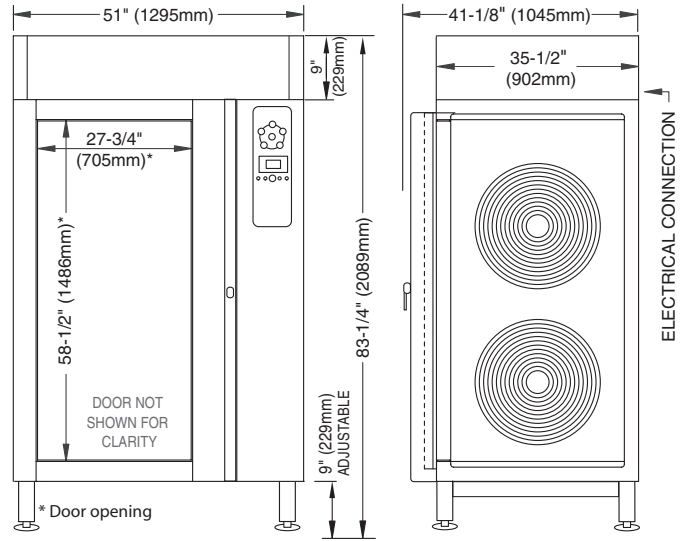

WEIGHT

	CABINET	REMOTE CONDENSER	ROLL-IN PAN CART
NET	902 lb (409 kg)	250 lb (113 kg)	120 lb (54 kg)
SHIPPING	1200 (544 kg)	380 lb (172 kg)	161 lb (73 kg)
CARTON DIMENSIONS: (L x W x H)			
48" x 55" x 98" (1219mm x 1397mm x 2489mm)			

WEIGHT (APPROXIMATE)

	CABINET	ROLL-IN PAN CART
NET	1152 lb (523 kg)	120 lb (54 kg)
SHIPPING	1450 lb (658 kg)	161 lb (73 kg)
CARTON DIMENSIONS: (L x W x H)		
55" x 47" x 99" (1397mm x 1194mm x 2515mm)		

REFRIGERATION

R404a Refrigerant

One (1) 3-1/2 hp Condensing Unit:

FREEZE MODE: 20,940 BTU's per hour at -5°F (-21°C)

CHILL MODE: 35,800 BTU's per hour at +20°F (-7°C)

PRODUCT/PAN CAPACITY

MAXIMUM PRODUCT CAPACITY -

Approximately 480 lb (218 kg), 300 quarts (380 liters)

MAXIMUM CHILLING CAPACITY -

Approximately 240 lb (109 kg), 150 qts (190 liters)

FULL-SIZE PANS: GASTRONORM 1/1:
Forty (40) 20" x 12" x 2-1/2" (530 x 325 x 65mm)

FULL-SIZE SHEET PANS:

Twenty (20)* 18" x 26" x 1"

*ON WIRE SHELVES ONLY. EXTRA OPTIONAL WIRE SHELVES REQUIRED FOR MAXIMUM CAPACITY SHOWN ABOVE.

INSTALLATION

OPTIONS AND ACCESSORIES

MODEL >	QC-3	QC-20	QC-40	QC-50	QC-50 REMOTE	QC-100	QC-100 REMOTE
Casters, 5" (127mm)	5005674	5005674	5005674	—	—	—	—
Prechill Sealing Strip	—	—	—	5008856	5008856	5008856	5008856
Remote Condenser Package	—	—	—	—	RE-27870	—	RE-34217
Roll-In Pan Cart (Trolley) 12•20 ^{ES} Combitherm and 12•20 Combimate® 10•20 ^{ESG} Combitherm and 12•20 Combimate® 20•20 ^{ES} Combitherm and 20•20 Combimate® 20•20 ^{ESG} Combitherm and 20•20 Combimate®	—	—	—	UN-27964 UN-27968 — —	UN-27964 UN-27968 — —	— — UN-27970 UN-27970	— — UN-27970 UN-27970
Weather Protective Enclosure	—	—	—	—	HS-27871	—	HS-27872
Wire Shelves, Stainless Steel	SH-24112	SH-2346	SH-22584	SH-22473	SH-22473	SH-22473	SH-22473

INSTALLATION



ELECTRICAL

This appliance must be branch circuit protected with proper ampacities, in accordance with the wiring diagram. The Quickchiller must be properly grounded in accordance with the National Electrical Code and applicable local codes. Wire size for the main incoming power to the unit must match the minimum size listed in the specifications applicable to the specific Quickchiller model. For supply connections, locate the wire size listed in this manual.

Before operating the chiller, check all cable connections in the electrical connection area for tightness since connections can loosen during transport.

NOTE: After electrical connections have been completed, operate the appliance in any chilling mode for a period of 15 minutes and recheck the main power connections at the terminal block to make certain they remain tight.

DANGER

To avoid electrical shock, this appliance MUST be adequately grounded in accordance with local electrical codes or, in the absence of local codes, with the current edition of the National Electrical Code ANSI/NFPA No. 70. In Canada, all electrical connections are to be made in accordance with CSA C22.1, Canadian Electrical Code Part 1 or local codes.

DANGER



ELECTRICAL CONNECTIONS MUST BE MADE BY A QUALIFIED SERVICE TECHNICIAN IN ACCORDANCE WITH APPLICABLE ELECTRICAL CODES.

ELECTRICAL SPECIFICATIONS

VOLTAGE PHASE CYCLE/HZ	QC-3	QC-20	QC-40	QC-50	QC-100
SELF-CONTAINED					
208-240VAC 1 ph 50/60 Hz					
RECOMMENDED CIRCUIT AMPERAGE:	20 amps	20 amps	30 amps	40 amps	60 amps
RECOMMENDED WIRE SIZE:	12/2 w.g.	12/2 w.g.	10/2 w.g.	8/2 w.g.	6/2 w.g.
NO CORD AND PLUG					
VOLTAGE PHASE CYCLE/HZ	QC-3	QC-20	QC-40	QC-50	QC-100
SELF-CONTAINED					
208-240VAC 3 ph 50/60 Hz					
RECOMMENDED CIRCUIT AMPERAGE:	NOT AVAILABLE	NOT AVAILABLE	NOT AVAILABLE	20 amps	40 amps
RECOMMENDED WIRE SIZE:				12/3 w.g.	8/3 w.g.
380-415VAC 3 ph 50/60 Hz					
RECOMMENDED CIRCUIT AMPERAGE:	NOT AVAILABLE	NOT AVAILABLE	30 amps	NOT AVAILABLE	30 amps
RECOMMENDED WIRE SIZE:			10/2 w.g.		10/2 w.g.
NO CORD AND PLUG					
VOLTAGE PHASE CYCLE/HZ	QC-3	QC-20	QC-40	QC-50	QC-100
REMOTE COMPRESSOR (Cabinet Only)					
208-240VAC 1 ph 50/60 Hz					
RECOMMENDED CIRCUIT AMPERAGE:	NOT AVAILABLE	NOT AVAILABLE	NOT AVAILABLE	20 amps	30 amps
RECOMMENDED WIRE SIZE:				12/2 w.g.	10/2 w.g.
NO CORD AND PLUG					

Wire diagrams are located near the top of the unit, close to the compressor or control panel.

OPERATION

OPERATING INTRODUCTION

The Alto-Shaam® Quickchiller™ is a processing refrigeration system designed to rapidly and uniformly decrease the temperature of hot foods to either a chilled or frozen state. This process provides enhanced safety, longer storage life and better production efficiency.

Rapid reduction in the temperature of hot foods inhibits the growth of bacteria and provides a safe, five-day chilled food refrigerated storage period from the time of preparation to the time of service. Enhanced storage time offers the food service operation considerable production efficiency. As an example, a daily menu item can be reduced from daily preparation to a preparation schedule consisting of two days per week.

The Alto-Shaam Quickchiller can be effectively utilized in several types of food service programs:



1. TRADITIONAL COOK-SERVE KITCHENS —

Quick chilling can be used to help streamline production in operations where foods are prepared for immediate service. Preparation of labor intensive entrées can be scheduled for production several days before service. Chilling foods provides the ability to rethermalize these items at a later date while maintaining both safety and product quality.

2. MODIFIED COOK-CHILL OPERATIONS—

where a significant portion of food is cooked for immediate service and a smaller portion of more labor intensive, hot food items are prepared in advance, chilled and reheated when required for service.

3. FULL COOK-CHILL OPERATIONS —

where all hot food production is prepared in advance of service requirements and held in refrigerated prepared food inventories. Hot food preparation takes place over a five-day production schedule.

The Quickchiller cooling or freezing process is accomplished with the utilization of large compressors and fans that are electronically controlled through the parameters entered by the operator on the control panel located at the front of the cabinet. The Quickchiller provides the operator with the ability to chill food products to a set cavity temperature by time or by internal product temperature using one or more food probes. When the specified chill time has elapsed or the probe temperature(s) has been reached the

Quickchiller will convert to a holding mode at a temperature specified for either refrigeration or frozen product maintenance. The Quickchiller control maintains a record of the length operating time used for each current cycle. After the chill cycle has ended and the unit is maintaining a holding temperature mode, the chiller control will initiate an automatic defrost cycle when required.

OPERATION

CHILL PROCESSING CYCLES

The Alto-Shaam Quickchiller uses high velocity cold air circulation to remove heat from prepared foods for the purpose of rapidly reducing temperatures through the danger zone and providing maximum storage life. Cold air is evenly directed across each pan from the control side of every Quickchiller model to assure rapid cooling.

The high velocity cold air produced by the Quickchiller removes insulating layers of warm moist air that surrounds hot products. The rapid removal of these insulating layers of heat reduces food temperatures significantly faster than any other method of temperature reduction and provides enhanced food safety.

Because the basic performance of the Quickchiller relies on high velocity air movement around each container of food, it is important to load the food by placing pans directly into the pan slides. Always use the pan slides to support the edges of 12" x 20" steam table pans (GN 1/1). Use a wire shelf for pan support when using 18" x 26" sheet pans; 12" x 10" steam table pans (GN 1/2); loaf pans; entree plates; and other small containers.

 CAUTION	
	TO MAINTAIN SANITATION CONTROL, ALL FOODS FOR QUICK-CHILL OR QUICK-FREEZE PROCESSING MUST BE AT A TEMPERATURE ABOVE 140°F (60°C) AND MUST BE TIGHTLY COVERED.

QUICKCHILLER OPERATION MODES

► PROCESSING WITH THE USE OF PROBES

Probe usage provides chill or frozen food processing activation and termination through use of a food probe or probes inserted into the center of the food. The cycle is automatically terminated when the center of the food reaches the probe sensing temperature set by the operator. In units with multiple probes, all probes must reach the sensing temperature set by the operator to trigger automatic termination of the cycle.

► PROCESSING BY TIME

The time mode provides processing activation and termination based on a timed cycle selected by the operator. Upon expiration of the timed cycle, the cabinet automatically reverts to the designated holding cycle temperature.

► HOLDING

Following processing completion, a holding cycle maintains the temperature to safely hold foods after processing. The holding cycle will also maintain a holding compartment temperature between processing cycles.

INITIAL QUICKCHILLER OPERATION

PRECHILLING THE CABINET

The Quickchiller should be prechilled prior to placing hot foods into the cabinet. In models equipped with a roll-in cart (trolley), always maintain an empty food cart inside the chiller when prechilling to eliminate air loss through the bottom of the chiller cabinet door. An optional *Prechill Sealing Strip* (Item #5008856) may also be used for this purpose.

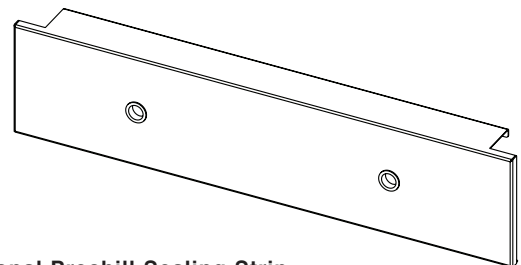

Optional Prechill Sealing Strip

5008856

OPERATION

ADDITIONAL INFORMATION

- Clean the Quickchiller and probes prior to use and make certain all processing modes are operating properly before chilling or freezing foods.
- To maintain proper operation of the Quickchiller, always allow the unit to defrost whenever the “**DEFROST OVERDUE**” warning appears in the display.
- For optimum performance, allow the Quickchiller to prechill for a minimum of 30 minutes before loading pans of food.
- Never overload the Quickchiller.
- It is important to be familiar with and adhere to all local food codes.
- Cook foods properly in preparation for blast chilling or freezing.
- Foods should be portioned into shallow pans to a depth not to exceed 2-inches (51mm).
- Pans must be covered prior to the chilling or freezing process.
- Always follow the recommended shelf life for chilled food products. Hold chilled foods under refrigeration for a maximum of 5 days including the day of production and the day of consumption.
- According to U.S. food code regulations, all chilled products must be reheated to an internal temperature of 165°F (74°C) prior to serving.

DOOR

If the Quickchiller door is opened during any running chill or freeze cycle, the fans will disengage. When the door is closed, the fans will reengage and the chiller will resume operation. When the door is opened, the display will reverse. When the unit is in operation and not in the “off mode”, a “**DOOR OPEN**” message will appear on the display along with the normal chill data. If the door is open for more than 2 minutes, then the beeper will sound every 10 seconds.

FAN OPERATION

During the initial cooling of the Quickchiller, an evaporator fan delay system will prevent the chilling fans from engaging until the evaporator coil temperature is below 30°F (-1°C). The fans will continue to run until the evaporator coil temperature is above 60°F (16°C).

The Quickchiller will only trigger an automatic defrost cycle during the refrigerated **Hold Temp** mode. If the chiller is in any other mode when the 6-hour Fan Timer limit plus one additional hour has elapsed, the display will indicate a warning message “**DEFROST OVERDUE**” and the control will produce an audible signal every ten seconds until a defrost is conducted.







POWER OUTAGE

“**POWER WAS OFF**” will appear in the display whenever operation is interrupted by a power outage. The control will produce an audible signal every 10 seconds and the display will indicate the amount of time the power was off. If consecutive power outages occur before the first outage has been acknowledged, the control will accumulate the total amount of outage time up to a period of 4 hours. After a period of 24 hours, accumulated time will be shown as greater than 24 hours, i.e., **>24**.

Press the **PROGRAM** key to clear the display and stop the audible signal.

OPERATION

CONTROL PANEL IDENTIFICATION

-  **POWER**
ON/OFF POWER BUTTON.
-  **SOFT CHILL** ... To rapidly decrease the temperature of foods by internal product probe temperature or time within a range of 24°F to 36°F (-4°C to 2°C). Soft Chill is recommended for less dense food items that chill quickly. The mode automatically converts to a refrigerated holding temperature at the end of the chill cycle.
-  **HOLD TEMP** ... The mode for refrigerated storage within a temperature range of -5°F to +40°F (-21°C to +4°C). Hold Temp offers continuous refrigerated storage without the utilization of food probes or a timer. Hold Temp always defaults to the default hold temperature, found under the User Settings.
-  **HARD CHILL** ... To rapidly decrease the temperature of foods by internal product probe temperature or time within a range of 11°F to 23°F (-11°C to -5°C). Hard Chill is recommended for more dense food items. The mode automatically converts to refrigerated holding temperature at the end of the chill cycle.
-  **QUICK FREEZE** ... The mode for rapid freezing and frozen food maintenance by internal product probe temperature or time within a temperature range of -10°F to +10°F (-23°C to -12°C). The mode automatically converts to a frozen food holding temperature at the end of the quick freeze cycle.
-  **START/STOP** ... Button used to initiate operating modes, set time and temperatures, and to set specific chiller program functions.
-  **PROGRAM** ... Button used to modify or select specific chiller programming functions.

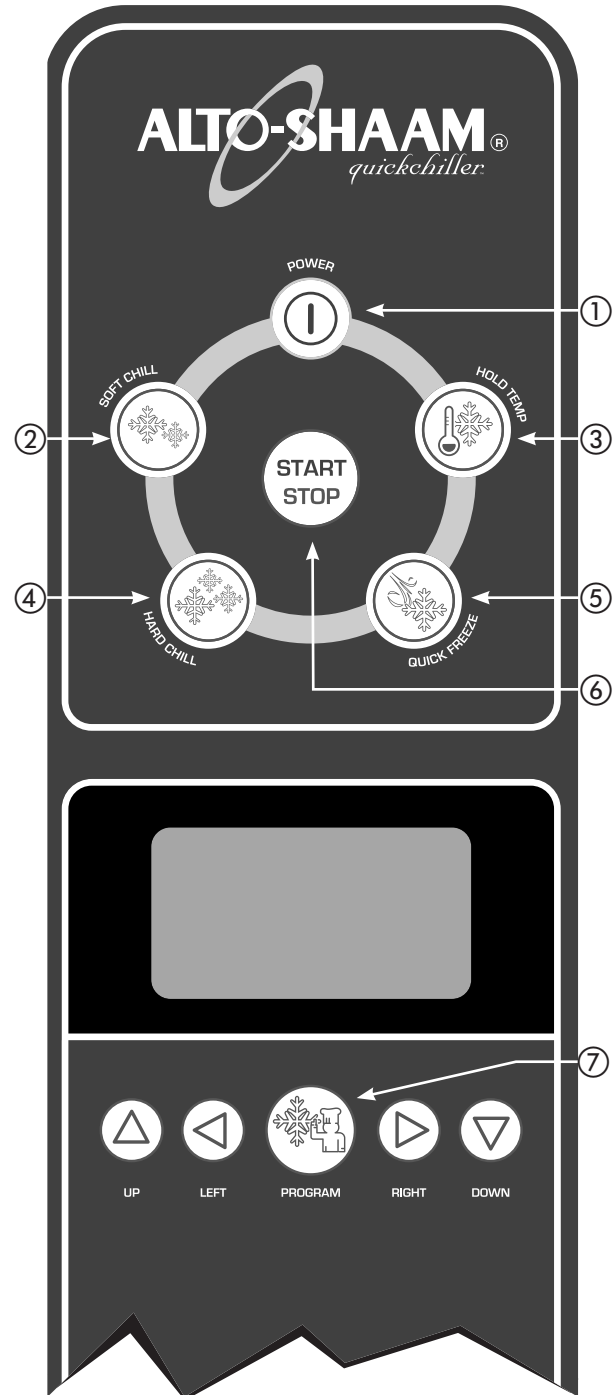

OPERATION

BASIC OPERATION

MANUAL OPERATION

1.  Starting from the **OFF** position, press the power key **ON**.

The Alto-Shaam name will illuminate and the **SELECTION SCREEN** will appear on the display. The compressor will become energized and will begin to operate if required by the sensors.

2. Press the desired mode key. Mode will operate at last settings entered.

- a.  **Soft Chill** - Select Soft Chill for less dense items such as fish or vegetables.
- b.  **Hard Chill** - Select Hard Chill for items such as meats or casseroles.
- c.  **Quick Freeze** - Select Quick Freeze to freeze items and transfer them directly to your freezer.
- d.  **Hold Temp** - Used to hold chilled items at a refrigerated temperature.

Note: The Alto-Shaam Quickchiller uses high velocity cold air circulation to remove heat from prepared foods. Therefore pans must be covered prior to the chilling or freezing process to prevent food from drying out.

3.  Press the **START/STOP** key to begin your chill or hold cycle.

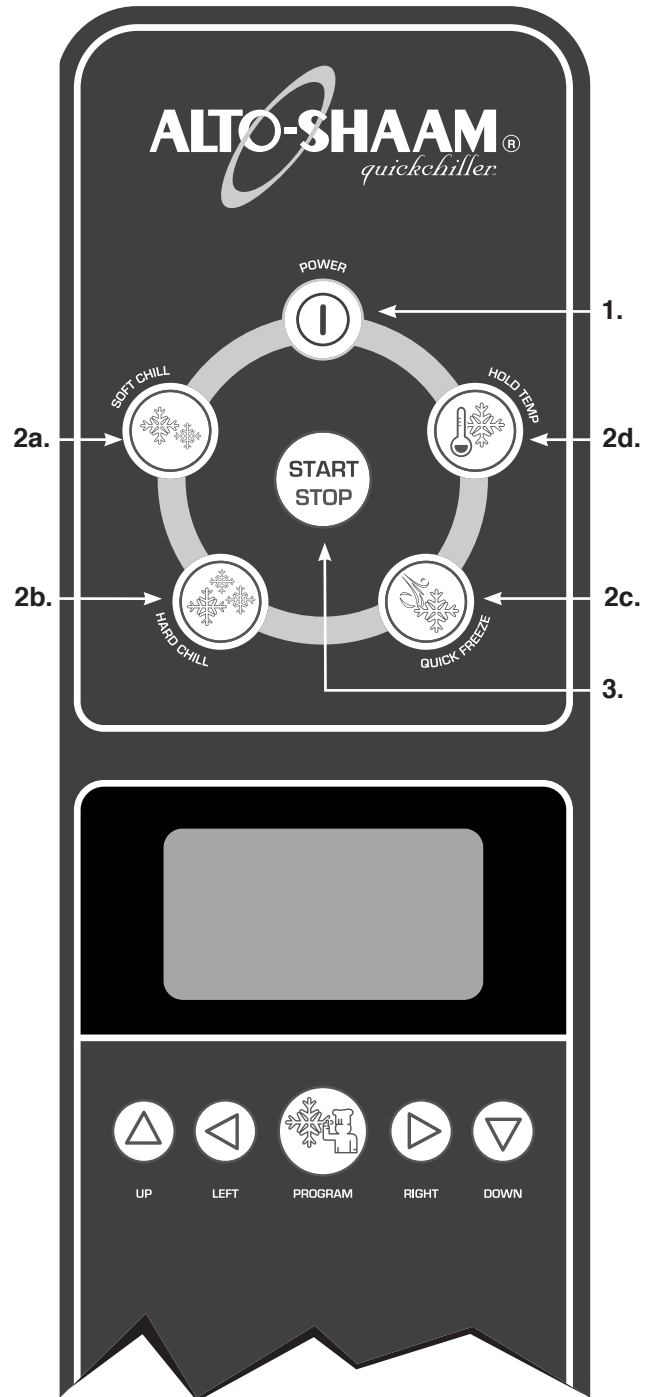

CAUTION



NEVER STACK PANS DIRECTLY ON TOP OF EACH OTHER. STACKED PANS WILL RESTRICT AIR FLOW AND INCREASE CHILL PROCESSING TIME.

CAUTION



ADEQUATE SPACING MUST BE ALLOWED BETWEEN PANS FOR PROPER AIR CIRCULATION FOR BOTH PROCESSING AND SUBSEQUENT HOLDING.

OPERATION

ADVANCED OPERATION

The date and time will appear in the display when the unit is off. When the unit is turned on, the screen will read: “**SELECT MODE OR PRESS START TO SELECT PRESET**”

To initiate any Quickchiller operating mode, power must initially start from the **OFF** position or an operating mode must be halted by pressing the **START/STOP** key so that the **SELECTION SCREEN** appears on the display.

NOTE: With the exception of the QC-3 counter top Quickchiller model, the Alto-Shaam name on the control panel will illuminate whenever the power key is pressed to the **ON** position.

HOLD TEMP



Starting from the **OFF** position, press the power key **ON**. The **SELECTION SCREEN** will appear on the display. The compressor will become energized and will begin to operate if required by the sensors.



Press the **HOLD TEMP** key. The display will indicate the default hold temperature (changeable in User Settings).

To change the displayed temperature, press the up ▲ or down ▼ arrow key to increase or decrease the temperature display within the refrigeration storage parameters of the **Hold Temp** mode -5°F to +40°F (-21°C to +4°C).

NOTE: THE MODIFIED HOLDING TEMPERATURE SET-POINT IS NOT SAVED. THE DEFAULT HOLD TEMPERATURE CAN BE CHANGED UNDER USER SETTINGS.



Press the **START/STOP** key to begin operation of the Quickchiller in the **Hold Temp** mode.

The display will indicate:

1. The length of time the chiller is operating in the **Hold Temp** mode.
2. The temperature set by the operator.
3. The air temperature inside the chiller compartment.
4. The temperature of all food probes.

WHEN IN THE HOLD TEMP MODE AFTER A CHILL MODE:

Press the **UP** ▲ arrow key to display the maximum sensor temperature achieved during the completed chill cycle. Press the **DOWN** ▼ arrow key to display the minimum sensor temperature achieved during the completed chill cycle. Press the right ▶ or left ◀ arrow key to display the Probe Done Time.

CAUTION



NEVER STACK PANS DIRECTLY ON TOP OF EACH OTHER. STACKED PANS WILL RESTRICT AIR FLOW AND INCREASE CHILL PROCESSING TIME.

CAUTION



ADEQUATE SPACING MUST BE ALLOWED BETWEEN PANS FOR PROPER AIR CIRCULATION FOR BOTH PROCESSING AND SUBSEQUENT HOLDING.

OPERATION

ADVANCED OPERATION

QUICK FREEZE, HARD CHILL, SOFT CHILL

MANUAL OPERATION

1.  Starting from the **OFF** position, press the power key **ON**.

The Alto-Shaam name will illuminate and the **SELECTION SCREEN** will appear on the display. The compressor will become energized and will begin to operate if required by the sensors.

2. Press the desired mode key.



The display will give an overview of the current set-temperatures for the mode.



If the current settings are acceptable, press the **START/STOP** key to begin your chill cycle.



If modifications are required, press the **PROGRAM** key and proceed to **step 3**.

3. The display will require the operator to select between chilling by **PROBE** or by **TIME**.

Select the desired chill method (time or probe) by pressing the right **▶** or left **◀** arrow keys.



Press the **PROGRAM** key to continue.

- 3a. If **TIME** was selected, use the right **▶** or left **◀** arrow keys to highlight chill, hold, or time, then press the up **▲** or down **▼** arrow keys to change accordingly.
- 3b. If **PROBE** was selected, select top, middle and lower probe using right **▶** or left **◀** arrow keys and then press the up **▲** or down **▼** arrow keys to change accordingly.

NOTE: QC-3 and QC-20 will display only one probe.

4.  Once the desired settings are entered, press the **START/STOP** key to begin chilling.

Chilling by Time

When chilling by time, the display will indicate a count-down of the time, the air temperature, and the temperature of each food probe. After time has expired, the chiller will automatically convert to the set holding mode.

Chilling by Probe

When chilling by probe, the display will indicate the length of time the product has been chilling, the interior compartment set temperature, and the air temperature. The display will also indicate the temperature of each probe along with "ACT." to advise the operator that the individual probe is active. As each probe reaches the set point value, the display will indicate "DONE." When all probes reach the individual set point value, the chiller will automatically convert to the holding mode.

Note: When a removable probe is unplugged, it is assumed to be at the set-point, and it will display "UNPLUGGED" on the display instead of the actual and temperature set points.

WHEN IN THE HOLD TEMP MODE AFTER CHILLING BY PROBE:

Press the **RIGHT ▶** or **LEFT ◀** arrow key to display the length of time it took for each probe to achieve set temperature.

THESE DATA ARE RETAINED UNTIL A NEW PROBE CYCLE IS COMPLETED.

FACTORY DEFAULT SET POINTS

Quickchiller >		Default Set Points		
Preset	Mode	Chill	Probe	Hold
1. Beans	Hard Chill	14°F	38°F	38°F
2. Beef	Hard Chill	14°F	38°F	38°F
3. Casserole	Hard Chill	14°F	38°F	38°F
4. Chicken Breast	Soft Chill	34°F	38°F	38°F
5. Chicken Whole	Hard Chill	14°F	38°F	38°F
6. Duck	Hard Chill	14°F	38°F	38°F
7. Fish	Soft Chill	34°F	38°F	38°F
8. Ground Meat	Hard Chill	14°F	38°F	38°F
9. Lamb	Hard Chill	14°F	38°F	38°F
10. Lasagna	Hard Chill	14°F	38°F	38°F
11. Pork	Hard Chill	14°F	38°F	38°F
12. Potatoes	Hard Chill	14°F	38°F	38°F
13. Rice	Hard Chill	14°F	38°F	38°F
14. Sauce	Hard Chill	14°F	38°F	38°F
15. Sheet Cake	Soft Chill	34°F @ 10 min.	—	38°F
16. Soup	Hard Chill	14°F	38°F	38°F
17. Stew	Hard Chill	14°F	38°F	38°F
18. Stuffing	Hard Chill	14°F	38°F	38°F
19. Turkey	Hard Chill	14°F	38°F	38°F
20. Vegetables	Soft Chill	34°F	38°F	38°F

OPERATION

ADVANCED OPERATION

PRESET PROGRAM OPERATION

1. Starting from the **OFF** position, press the power key **ON**. The Alto-Shaam name will illuminate and the **SELECTION SCREEN** will appear on the display. The compressor will become energized and will begin to operate if required by the sensors.
2. At the **SELECTION SCREEN** press the **START/STOP** key to access the presets.

The first five of the following preset menu selections will appear in the display.

PRESET SELECTIONS	
1. Beans	11. Pork
2. Beef	12. Potatoes
3. Casserole	13. Rice
4. Chicken Breast	14. Sauce
5. Chicken Whole	15. Sheet Cake
6. Duck	16. Soup
7. Fish	17. Stew
8. Ground Meat	18. Stuffing
9. Lamb	19. Turkey
10. Lasagna	20. Vegetables

3. Press the up ▲ or down ▼ arrow keys to scroll through the preset menu items.
4.  When desired preset is highlighted, press the **START/STOP** key.

The Quickchiller will show the values previously programmed by the operator or will begin chilling if the Presets are locked.
5.  Press the **START/STOP** key again to begin operation.

PROGRAMMING PRESETS

1. Starting from the **OFF** position, press the power key **ON**. The Alto-Shaam name will illuminate and the **SELECTION SCREEN** will appear on the display. The compressor will become energized and will begin to operate if required by the sensors.
2. At the **SELECTION SCREEN** press the **START/STOP** key to access the presets.
3. Press the up ▲ or down ▼ arrow keys until the arrow points to the preset menu program desired.
4.  Press the **START/STOP** key.

Press the desired mode key.



Press the up ▲ or down ▼ arrow keys to adjust temperature. **Skip to Step 6.**



The display will give an overview of the current set-temperatures for the mode.



To change the settings for the desired mode, press the **PROGRAM** key.

5. The Display will require the operator to select between chilling by **PROBE** or by **TIME**.

Select the desired chill method (time or probe) by pressing the right ▶ or left ◀ arrow keys.
 - a. If **TIME** was selected, use the right ▶ or left ◀ arrow keys to highlight chill, hold, or time, then press the up ▲ or down ▼ arrow keys to change accordingly.
 - b. If **PROBE** was selected, select top, middle and lower probe using right ▶ or left ◀ arrow keys and then press the up ▲ or down ▼ arrow keys to change accordingly.

NOTE: QC-3 and QC-20 will display only one probe.
6.  If settings are acceptable, press the **START/STOP** key. The preset settings will be saved and the operation will begin.

OPERATION

ADVANCED OPERATION

USER SETTINGS

CHANGING USER SETTINGS



Starting from the **OFF** position, press the power key **ON**. The Alto-Shaam name will illuminate and the **SELECTION SCREEN** will appear on the display. The compressor will become energized and will begin to operate if required by the sensors.



Press the **PROGRAM** key. The display will indicate the User Settings each time the **Program** key is pressed.

USER SETTINGS	
1. Start Manual Defrost	7. Default Hold Temperature
2. Defrost Frequency	8. HACCP Address
3. Language	9. Probe Verification
4. Date - YYYY/MM/DD	10. Presets
5. Time - HH:MM	11. Chill Modes
6. °F/°C - Fahrenheit/Celsius	12. Factory Reset

Press the up ▲ or down ▼ arrow keys to select the desired User Setting.

Press the right ► or left ◀ arrow keys to change the value.



Press the **PROGRAM** key to save settings and return to the **SELECTION SCREEN**.

PROGRAMMING USER SETTINGS

1. START MANUAL DEFROST



Select **Start Manual Defrost** and press the **START/STOP** key to initiate a manual defrost cycle. The defrost cycle will complete operation when the temperature of the coil or coils reach set-point values or after a period of 20 minutes, whichever occurs first.

2. DEFROST FREQUENCY

The display will indicate the length of time necessary to accrue before the Fan Timer triggers an automatic defrost cycle. This period of time can be adjusted by pressing the right ► or left ◀ arrow keys to increase or decrease automatic defrost cycle time (4-10 hours).

3. LANGUAGE

The display will indicate the currently selected language. Press the right ► or left ◀ arrow key to select English, Spanish, or French as the language of choice.

4. DATE

The display will indicate **YEAR**, **MONTH**, and **DAY OF MONTH** (YYYY/MM/DD). Press the up ▲ or down ▼ arrow key to select the date, time, and day, and the right ► or left ◀ arrow key to increase or decrease the numbers as required.

5. TIME

The display will indicate the current **TIME** of day (HH:MM). Press the up ▲ or down ▼ arrow key to select the hours or minutes and the right ► or left ◀ arrow key to increase or decrease the numbers as required.

6. °F/°C - Fahrenheit/Celsius

The display will indicate a choice between **Celsius** and **Fahrenheit** for Quickchiller temperature display readings. Press the right ► or left ◀ arrow key to toggle the setting.

7. HOLD DEFAULT

The display will indicate the default **HOLD** temperature. Press the right ► or left ◀ arrow key to increase or decrease the default holding temperature between a range of -5°F to +40°F (-21°C to +4°C).

8. HACCP ADDRESS

The display will indicate the **HACCP Address Number**. This item allows the operator to assign a specific identifying number (1 to 247) to the individual Quickchiller as part of a serial communication interface for the web-based, HACCP with Kitchen Management software package option. Press the right ► or left ◀ arrow key to increase or decrease the number.

9. PROBE VERIFICATION

With the probe verification selected, press the Start key to enter the probe verification mode.

The display will show the offset and the temperature of:

- Top Probe (WHERE APPLICABLE)
- Middle Probe (WHERE APPLICABLE)
- Bottom Probe (WHERE APPLICABLE)

If probe calibration is needed, place the probe in a glass of ice-water and let the probe settle in temperature. The temperature in the glass should be 32°F (0°C).

To calibrate, Press up ▲ or down ▼ arrow key to adjust between the probes, and the right ► or left ◀ arrow keys to adjust the calibration value.



Press the **PROGRAM** key to exit probe calibration mode.

10. PRESETS (0=UNLOCKED, 1=LOCKED)



If the presets are locked, pressing **START** on the desired preset will skip the mode overview and will start immediately. Factory default is **LOCKED**.

11. CHILL MODES (0=UNLOCKED, 1=LOCKED)



If the chill modes are locked, pressing the chill mode button will skip the mode overview and will start immediately. Factory default is **UNLOCKED**.

12. FACTORY RESET

Resets all presets and user-defined settings to factory default settings. **Warning: Pressing Factory Reset will erase all User Settings and Presets programmed by the user. All custom User Settings and Presets will need to be reprogrammed.**

OPERATION

FOOD PROBE USE

Unpacking Food Probes

1. Cut and remove the plastic ties keeping the probe cables coiled during shipment.

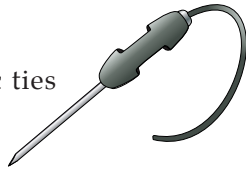

When removing the ties, exercise caution to avoid accidentally cutting the black plastic covers on the probe cable wires.

2. Uncoil the probe cables and insert the metal portion of each probe into the bracket mounted on the inside of the cabinet. Proper probe placement is in the following sequence:
Place the top probe (Product Probe 1) in the top bracket. On equipped models, place the center probe (Product Probe 2) in the middle bracket, and place the bottom probe (Product Probe 3) in the bottom bracket position.
3. Before using the probes, wipe each probe and probe tip with a disposable alcohol pad to clean and sanitize.

Probe Cleaning Procedures

1. Remove all food residues from probes between loads and at the end of each production shift. Wipe the entire probe, cable assembly, and probe holding bracket with warm detergent solution and a clean cloth.
2. Remove detergent by wiping each probe, probe cable, and holding bracket with clean rinse water and a cloth.
3. Wipe probes and probe brackets with disposable alcohol pad or sanitizing solution recommended for food contact surfaces.
4. Replace the probe into the proper probe bracket. Allow the probe and cable to air dry.
5. Wipe the each probe with a disposable alcohol pad prior to inserting the probe into a new food product.

USER INFORMATION

Time & Temperature Guidelines

To assure quality and safety in chilled processed food handling, it is important to observe the following guidelines.

1. All foods should be covered prior to chill or freeze processing.
2. The temperature of foods should be rapidly reduced from 140°F to 40°F (60°C to 4°C) within a period of 4 hours.
3. Foods can be safely removed from the chiller cabinet at a product temperature of 40°F (4°C) or lower.
4. Chilled foods should be stored under refrigeration designed to hold products at 34° to 38°F (1° to 3°C) for a maximum of 5 days or less. A 5-day shelf life includes the day of production and the day of consumption.
5. All potentially hazardous cooked foods that have been chilled followed by reheating and hot food holding must be reheated to a minimum core temperature of 165°F (74°C) for 15 seconds prior to serving. Refer to local food codes for possible exceptions.
6. Always reference and adhere to local food codes and HACCP guidelines with regard to time and temperature for chilling or frozen food processing.

Automatic Defrost

The Quickchiller will only trigger an automatic defrost cycle during the refrigerated **Hold Temp** mode. If the chiller is in any other mode when the Fan Timer limit plus one additional hour has elapsed, the display will indicate a warning message "**DEFROST OVERDUE**" and beep every 10 seconds until a defrost is conducted. A defrost can be initiated manually as indicated under User Settings in this manual, or by allowing the Quickchiller to enter the **Hold Temp** mode.

**ALLOW A MINIMUM OF
30 MINUTES OF PRECHILL
TIME BEFORE PROCESSING.**

OPERATION

FOOD HANDLING GUIDELINES

PRODUCT COVERING

To maintain sanitation control when loading the Quickchiller, foods should be above 140°F (60°C) and should be tightly covered. A tight cover is an important part of proper chilling methods and must be used to prevent the possibility of accidental contamination by airborne bacteria.

Stainless steel pan covers may be used. Stainless steel covered pans must include a label indicating pan contents and use-by date. A cover of clear plastic wrap is also acceptable.

When using plastic wrap as a food covering, make certain the wrap comes in direct contact with the surface of the product and extends around and down each side of the pan. This is an important step to ensure proper chilling times. Spacing left between the plastic wrap and the surface of the food creates an insulating air gap resulting in more product heat retention and a slower chilling rate.

Meat roasts and other larger, dense products should be no larger than a weight of 8 to 10 pounds (4 to 5 kg) per item. Because of the density of these products, chilling could take up to 4 hours. Due to longer chilling time required, it is also suggested these items be chilled at the end of the day with the chiller set in the automatic chill/hold mode. This method provides the operator with fully chilled product holding at a refrigerated temperature on the following day.

Prior to chilling, roasts must be wrapped in clear plastic and placed in the chiller. ***Do not slice roasted meats until the day of service.***

Portioned meat products such as pork chops or meat patties should be chilled directly on the sheet pans on which they were cooked. Cover the sheet pans with clear plastic wrap for chilling. After chilling, this type of product can be placed in steam table pans for refrigerated storage.

PORTIONING & PACKAGING

1. During portioning and packaging operations, all foods should be maintained at or above 140°F (60°C), or below 40°F (4°C).
2. If cooked foods exceed the processing capacity of the Quickchiller, place hot product in an appropriate back-up hot holding device such as an Alto-Shaam® Halo Heat Combimate holding cabinet which will accommodate a roll-in cart (trolley). Hold hot foods at a temperature above 140°F (60°C).

If a hot food holding cabinet is not available, place hot foods in short-term refrigerated storage until these products can be loaded into the Quickchiller for the next available processing cycle. Production of cooked foods should not exceed the processing capabilities of the chiller, therefore, do not adopt short-term refrigeration as a routine practice but use only in an emergency situation.

3. Fill containers to a 12 pound (5kg) limit or maximum depth of 2" (51mm) of product. Do not use plastic or Lexan® containers.
4. For faster cooling, place lids and over-wrap materials directly on the surface of foods. As previously indicated, air trapped between the lid and food surface acts as an insulator and will increase chill time.
5. For faster chilling times, place low profile foods such as chicken quarters, fish fillets, or ribs in low depth containers such as 1-1/2" (38mm) deep sheet pans.
6. Large cuts of meat and poultry that weigh a maximum of 8 to 10 pounds (4 to 5 kg) maximum should be individually wrapped with tight fitting film and placed on sheet pans in the chill cabinet.

OPERATION

QUICKCHILLER PAN CAPACITY:

The following Quickchiller Capacity Chart indicates the number of pans that can be accommodated in the appropriate size chiller for the chilling or freezing function. Additional pans can be accommodated *only* when using the Quickchiller for holding at a refrigerated temperature or at a maintenance temperature for frozen food.

DO NOT OVERLOAD THE QUICKCHILLER FOR THE PROCESSING FUNCTION.

QUICKCHILLER PAN CAPACITY CHART

CHILLER MODEL	NO. PANS	STANDARD PAN SIZES	TOTAL WEIGHT	GASTRONORM PAN SIZES	TOTAL
QC-3	3	12" x 20" x 2-1/2" pans	36 lb	530mm x 325mm x 65mm 1/1	16 kg
QC-20	5 10*	12" x 20" x 2-1/2" pans 18" x 26" x 1-1/2" pans	60 lb 60 lb	530mm x 325mm x 65mm 1/1 n/a	27 kg
QC-40	10* 10*	12" x 20" x 2-1/2" pans 18" x 26" x 1-1/2" pans	120 lb 60 lb	530mm x 325mm x 65mm 1/1 n/a	54 kg
QC-50	12 24* 12*	12" x 20" x 2-1/2" pans 12" x 10" x 2-1/2" pans 18" x 26" x 1-1/2" sheet pans	144 lb 144 lb 72 lb	530mm x 325mm x 65mm 1/1 265mm x 325mm x 65mm 1/2 n/a	65 kg 65 kg
QC-100	20 40 20*	12" x 20" x 2-1/2" pans 12" x 10" x 2-1/2" pans 18" x 26" x 1-1/2" sheet pans	240 lb 240 lb 120 lb	530mm x 325mm x 65mm 1/1 265mm x 325mm x 65mm 1/2 n/a	109 kg 109 kg

*ADDITIONAL WIRE SHELVES REQUIRED FOR MAXIMUM CAPACITY

NOTE: All metric equivalent sizes and capacities shown throughout this manual are approximate.

PRODUCT CAPACITY PER PAN:

Foods for chill or freeze processing should be portioned into shallow pans to a depth *not to exceed* 2-inches (51mm). The individual pan capacity chart below is provided as a general guideline to help determine the number of processing loads required for the total quantity of food to be processed.

INDIVIDUAL PAN CAPACITIES

Steam Table Pan:	12" x 20" x 2 1/2"	12 lb	Gastronorm 1/1	530mm x 325mm x 65mm	5,4 kg
Steam Table Pan:	12" x 10" x 2 1/2"	6 lb	Gastronorm 1/2	265mm x 325mm x 65mm	2,7 kg
Full-Size Sheet Pan:	18" x 26" x 1 1/2"	6 lb	n/a		
Half-Size Sheet Pans:	18" x 13" x 1 1/2"	3 lb	n/a		

EXAMPLE: 132 lb per batch ÷ 12 lb per 12" x 20" x 2 1/2" pan = **11 PANS**

60 kg per batch ÷ 5,4 kg per 325mm x 530mm x 65mm pan = **11 PANS**

OPERATION

THE FOLLOWING CHART OF PORTION SIZES AND SERVING CAPACITY PER PAN IS PROVIDED AS A GENERAL REFERENCE ONLY.

PORTION SIZES and PAN CAPACITIES			
PAN SIZE >	12" x 20" x 2-1/2"	325 x 530 x 65mm	
FOOD CATEGORY	SERVING SIZE	METRIC EQUIVALENT SERVING SIZE	SERVINGS PER PAN
BREAKFAST ITEMS:			
Griddle Cakes, Waffles, French Toast (2 TO 3 EACH)	4 oz	113 gm	48
Eggs	2 to 4 oz	57 to 113 gm	96 to 48
Breakfast Meats	2 oz	57 gm	96
Cooked Cereals or Grains	4 oz	113 gm	48
Fruit Compote	4 oz	113 gm	48
Meat, Poultry, Fish, Seafood	4 oz	113 gm	48
Casseroles and Extended Dishes	6 to 8 oz	170 to 227 gm	32 to 24
Vegetables	4 oz	113 gm	48
STARCHES:			
Potato, Rice, Pasta, Stuffings, Beans	4 oz	113 gm	48
Gravies and Au Jus	2 oz	57 gm	96
Sauces	4 oz	113 gm	48
Protein and Starch-Based Salads	4 to 6 oz	113 to 170 gm	48 to 32
DESSERTS:			
Pudding, Custard, Mousse, Jello	4 oz	113 gm	48

CARE AND CLEANING

CLEANING AND PREVENTIVE MAINTENANCE

PROTECTING STAINLESS STEEL SURFACES



It is important to guard against corrosion in the care of stainless steel surfaces. Harsh, corrosive, or inappropriate chemicals can completely destroy the protective surface layer of stainless steel. Abrasive

pads, steel wool, or metal implements will abrade surfaces causing damage to this protective coating and will eventually result in areas of corrosion. Even water, particularly hard water that contains high to moderate concentrations of chloride, will cause oxidation and pitting that result in rust and corrosion. In addition, many acidic foods spilled and left to remain on metal surfaces are contributing factors that will corrode surfaces.

Proper cleaning agents, materials, and methods are vital to maintaining the appearance and life of this appliance. Spilled foods should be removed and the area wiped as soon as possible but at the very least, a minimum of once a day. Always thoroughly rinse surfaces after using a cleaning agent and wipe standing water as quickly as possible after rinsing.

CLEANING AGENTS

Use non-abrasive cleaning products designed for use on stainless steel surfaces. Cleaning agents must be chloride-free compounds and must not contain quaternary salts. Never use hydrochloric acid (muriatic acid) on stainless steel surfaces. Always use the proper cleaning agent at the manufacturer's recommended strength. Contact your local cleaning supplier for product recommendations.

CLEANING MATERIALS

The cleaning function can usually be accomplished with the proper cleaning agent and a soft, clean cloth. When more aggressive methods must be employed, use a non-abrasive scouring pad on difficult areas and make certain to scrub with the visible grain of surface metal to avoid surface scratches. Never use wire brushes, metal scouring pads, or scrapers to remove food residue.

 CAUTION	
 NO SCRAPERS	TO PROTECT STAINLESS STEEL SURFACES, COMPLETELY AVOID THE USE OF ABRASIVE CLEANING COMPOUNDS, CHLORIDE BASED CLEANERS, OR CLEANERS CONTAINING QUATERNARY SALTS. NEVER USE HYDROCHLORIC ACID (MURIATIC ACID) ON STAINLESS STEEL. NEVER USE WIRE BRUSHES, METAL SCOURING PADS OR SCRAPERS.
 NO WIRE BRUSHES	
 NO STEEL PADS	

CARE AND CLEANING

INTERIOR CLEANING

Remove the roll-in cart (trolley) from cart equipped models. Open the quickchiller door to warm the interior of the cabinet.

1. Remove any loose food debris with a cleaning cloth or small hand broom.
2. Use a mild, non-abrasive detergent and warm water. Wipe-down the interior of the cabinet, removing all food residue. This includes the ceiling, floor, walls and fan panel.
Wipe-down the interior door panel and clean the vinyl gaskets. Make certain to clean under the gaskets to remove any mildew accumulation or food residue.
3. Rinse all interior surfaces including the cabinet door and gasket with clean water and a cloth. Remove all rinse water.
4. Wipe interior surfaces with a clean cloth and sanitizing solution for use on metal and vinyl food contact surfaces. This is an important step to control the build-up of unwanted mildew and mold in the refrigeration system.
5. Allow interior to air dry with door open.

EXTERIOR CLEANING



1. Wipe all exterior surfaces including the control panel, door frame, latches, and hinges with a damp cloth containing a mild, non-abrasive, non-chloride detergent solution.
2. Rinse detergent solution with a cloth and warm water. Allow exterior to air dry.
3. Polish with any standard stainless steel polish designed for use on food service equipment. When cleaning the exterior of the cabinet, always wipe with the grain of the stainless steel to avoid scratching or marring the finish. Avoid an accumulation of oil based polish or cleaner collecting along the edges of the keyboard overlay on the control box. Oil build-up around the control overlay could eventually loosen the panel.

DO NOT USE ABRASIVE CLEANING COMPOUNDS OR IMPLEMENTS.



DANGER



DISCONNECT UNIT FROM POWER SOURCE BEFORE CLEANING OR SERVICING.

PROBE CLEANING PROCEDURES

1. Remove all food soil from probes between loads and at the end of each production shift. Wipe entire probe, cable assembly, and probe holding door bracket with warm detergent solution and a clean cloth.
2. Remove detergent by wiping each probe, cable, and bracket with clean rinse water and a cloth.
3. Wipe probes and probe brackets with disposable alcohol pad or sanitizing solution recommended for food contact surfaces
4. Allow probe and cable to air dry in probe holding door bracket.
5. Wipe the probe with a disposable alcohol pad prior to inserting into a new food product.

FOOD TROLLEY CLEANING

1. Take food trolley to a cart wash area. Trolleys may be cleaned using any mild cleaning detergent and warm water.
2. Hand wipe all framing, slides, drip pan, and base. Thoroughly clean debris from the casters. A spray hose can be used for easier cart cleaning.
3. Remove detergent solution with warm water.
4. Wipe or spray with a sanitizing solution designed for use on metal and vinyl food contact surfaces.
5. Allow trolley to air dry.

MONTHLY COMPRESSOR & CONDENSER MAINTENANCE

Keep the condenser coils free of dust and debris build-up to insure proper air circulation and cooling of the refrigeration system.

1. Turn power supply to the cabinet OFF.
2. Using a vacuum or small hand broom, brush the condenser coils in a vertical motion to remove any accumulated dust or debris.
3. Turn breaker switches ON and replace air grill.

DANGER



AT NO TIME SHOULD THE INTERIOR OR EXTERIOR BE STEAM CLEANED, HOSED DOWN, OR FLOODED WITH WATER OR LIQUID SOLUTION OF ANY KIND. DO NOT USE WATER JET TO CLEAN.



SEVERE DAMAGE OR ELECTRICAL HAZARD COULD RESULT.
WARRANTY BECOMES VOID IF APPLIANCE IS FLOODED

TROUBLESHOOTING

CONTROL ERROR DISPLAYS

CONTROL DISPLAY	ACTION REQUIRED
<p>Real Time Clock Bad</p> <p><i>E-60: REAL TIME CLOCK DEFAULTS LOADED, VERIFY CORRECT TIME, POWER CYCLE UNIT TO CLEAR THIS MESSAGE.</i></p>	<p>This is likely caused by the unit having been unplugged for an extended amount of time. The data stored in the Real-Time Clock has been reset to the factory default values. Contact service if problem persists.</p>
<p>Real Time Clock Not Detected</p> <p><i>E-61: REAL TIME CLOCK NOT DETECTED. POWER CYCLE UNIT AND CALL FOR SERVICE IF THE PROBLEM PERSISTS.</i></p>	<p>Real Time Clock not detected. Contact service if problem persists.</p>
<p>Button Stuck</p> <p><i>E-90: BUTTON STUCK. CHECK ALL BUTTONS AND ERROR WILL CLEAR WHEN THE PROBLEM HAS BEEN RESOLVED</i></p>	<p>This error message indicates that a button is stuck. Check all buttons. Error will clear when the problem has been solved. Contact service if problem persists.</p>
<p>Using Default Function Values</p> <p><i>E-80 - EEPROM ERROR USING DEFAULT FUNCTION VALUES</i></p>	<p>This error message indicates the control memory is not correctly reading user-set values. The Quickchiller will remain operational but the user defined settings will be reloaded to the default values. The control will revert to factory default settings and will require operator modification each time the unit is used. Call Service. Acknowledge error by pressing the power button.</p>
<p>Probe Open/Shorted</p> <p><i>PROBE N* OPEN -OR- PROBE N* SHORTED CALL FOR SERVICE</i></p>	<p>This error message indicates a problem with the probe identified within the display. The Quickchiller will operate normally in the Time mode but will not operate in the Probe mode. Call service.</p> <p>*N signifies probe number that is shorted: 1= top, 2= middle, 3= bottom</p>
<p>Cavity Open Shorted</p> <p><i>CAVITY SENSOR OPEN OR SHORTED. CALL FOR SERVICE</i></p>	<p>This error message indicates a problem with the interior cavity sensor. The Quickchiller will not operate in any operational mode. Call service.</p>
<p>Coil Open Shorted</p> <p><i>COIL N* OPEN OR COIL N* SHORTED CALL FOR SERVICE</i></p>	<p>This error message indicates a problem with the display identified coil sensor. The Quickchiller will remain operational but will extend the defrost cycle to the full period of 20 minutes. Call service.</p> <p>*N signifies coil number that is shorted.</p>
<p>Bad Calibration</p> <p><i>E-81: BAD CALIBRATION. PLEASE CALL SERVICE AD1-0=(PASS)(FAIL) AD1-1=(PASS)(FAIL) AD2-0=(PASS)(FAIL) AD2-1=(PASS)(FAIL) AD3-0=(PASS)(FAIL) AD3-1=(PASS)(FAIL)</i></p>	<p>Calibration bad. Call service.</p> <p>Note: Display will signify <i>PASS</i> where calibration is good, or <i>FAIL</i> where calibration is bad.</p>
<p>Requires Calibration</p> <p><i>E-82: REQUIRES CALIBRATION. PLEASE CALL SERVICE</i></p>	<p>Requires Calibration. Call service.</p>
<p>Power Failure</p> <p><i>POWER WAS OFF FOR HH:MM PRESS PROGRAM TO ACKNOWLEDGE</i></p>	<p>Power has been off. Press Program to acknowledge.</p> <p>NOTE: If such an event has occurred, it is strongly recommended that you ensure the food is safe for consumption according to local health regulations.</p>

SERVICE

MODEL: QC-3 CONTROL

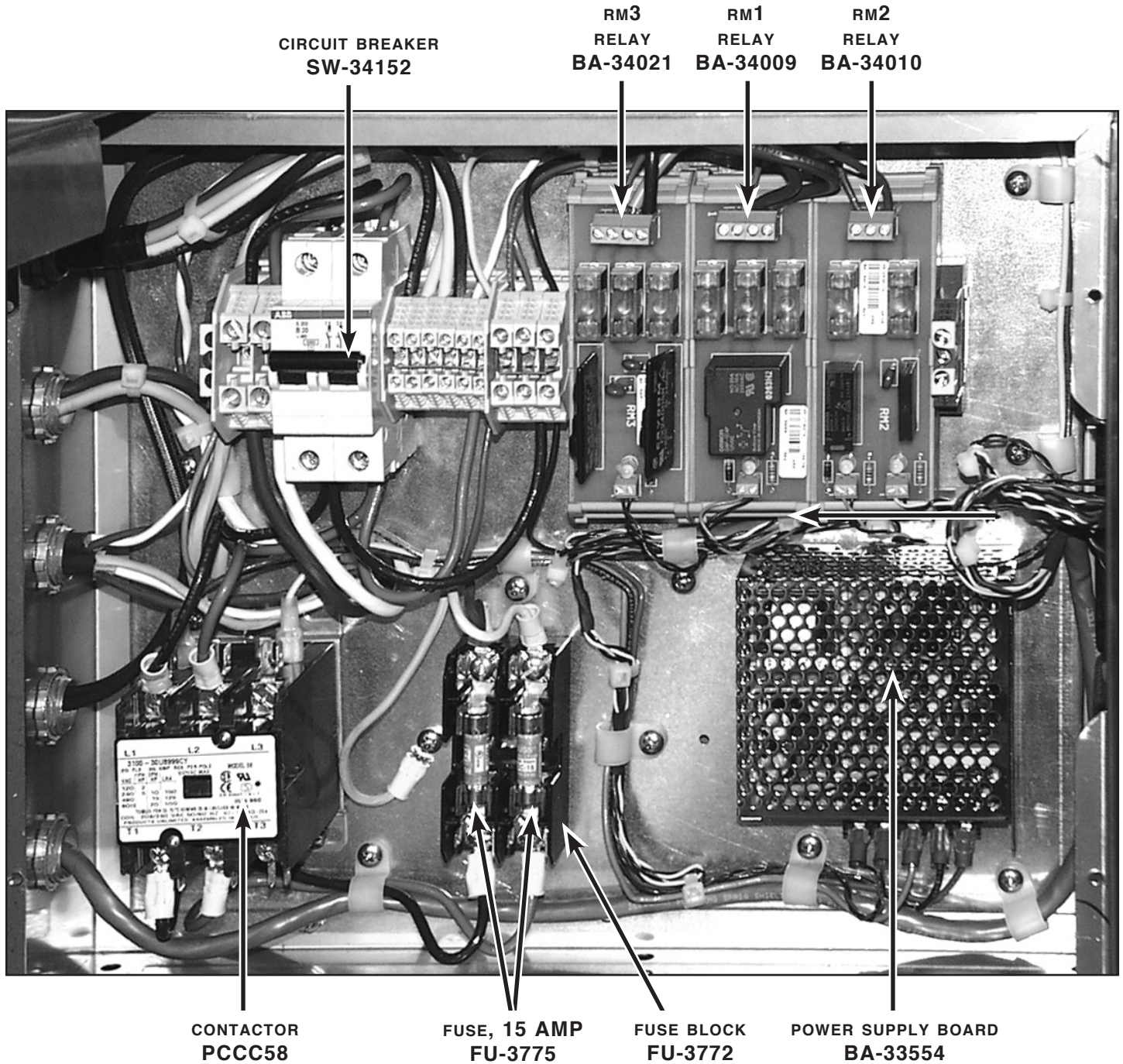

Part numbers and drawings are subject to change without notice.

SERVICE

MODEL: QC-3 COIL

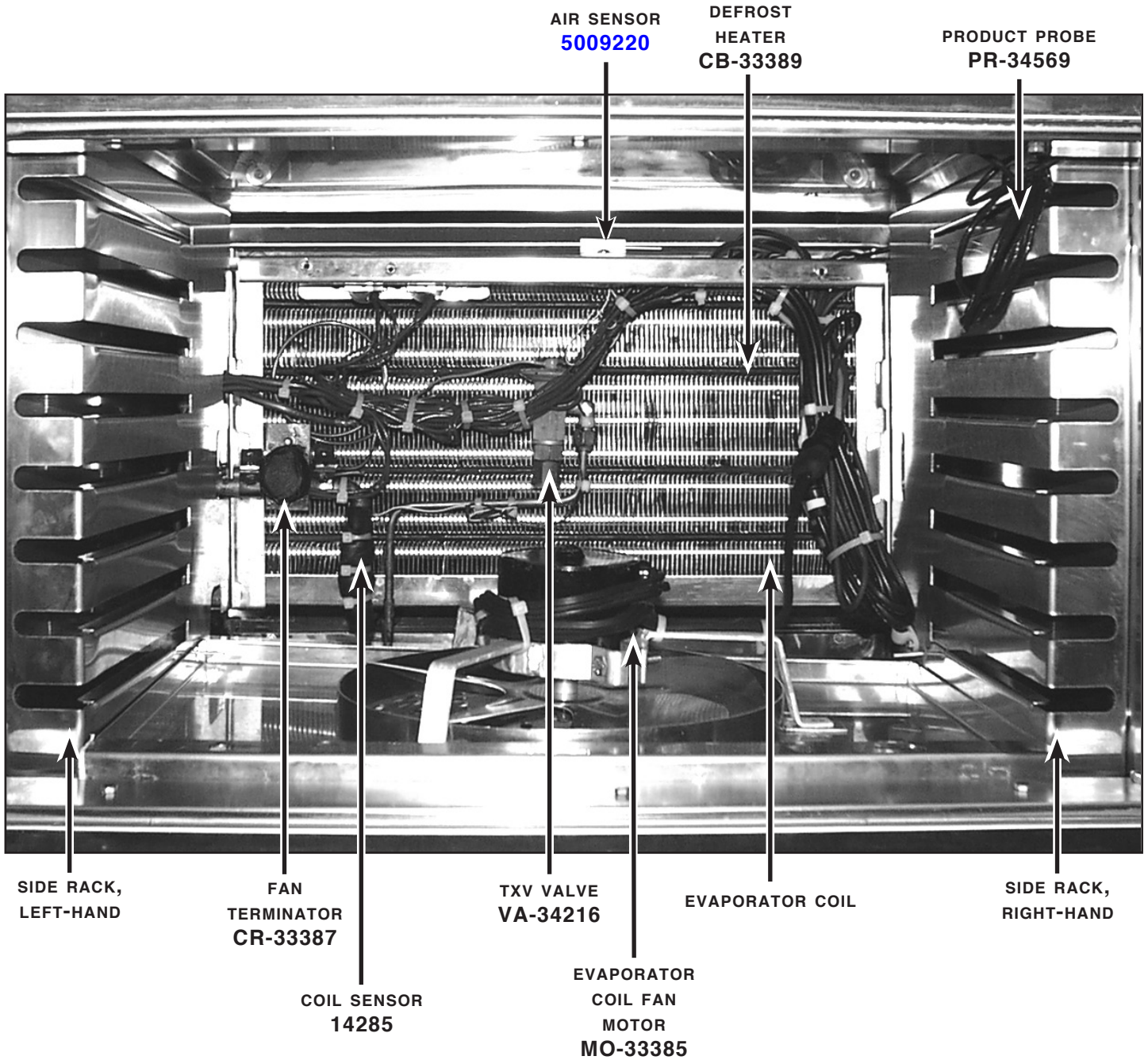

Part numbers and drawings are subject to change without notice.

SERVICE

MODEL: QC-20 CONTROL

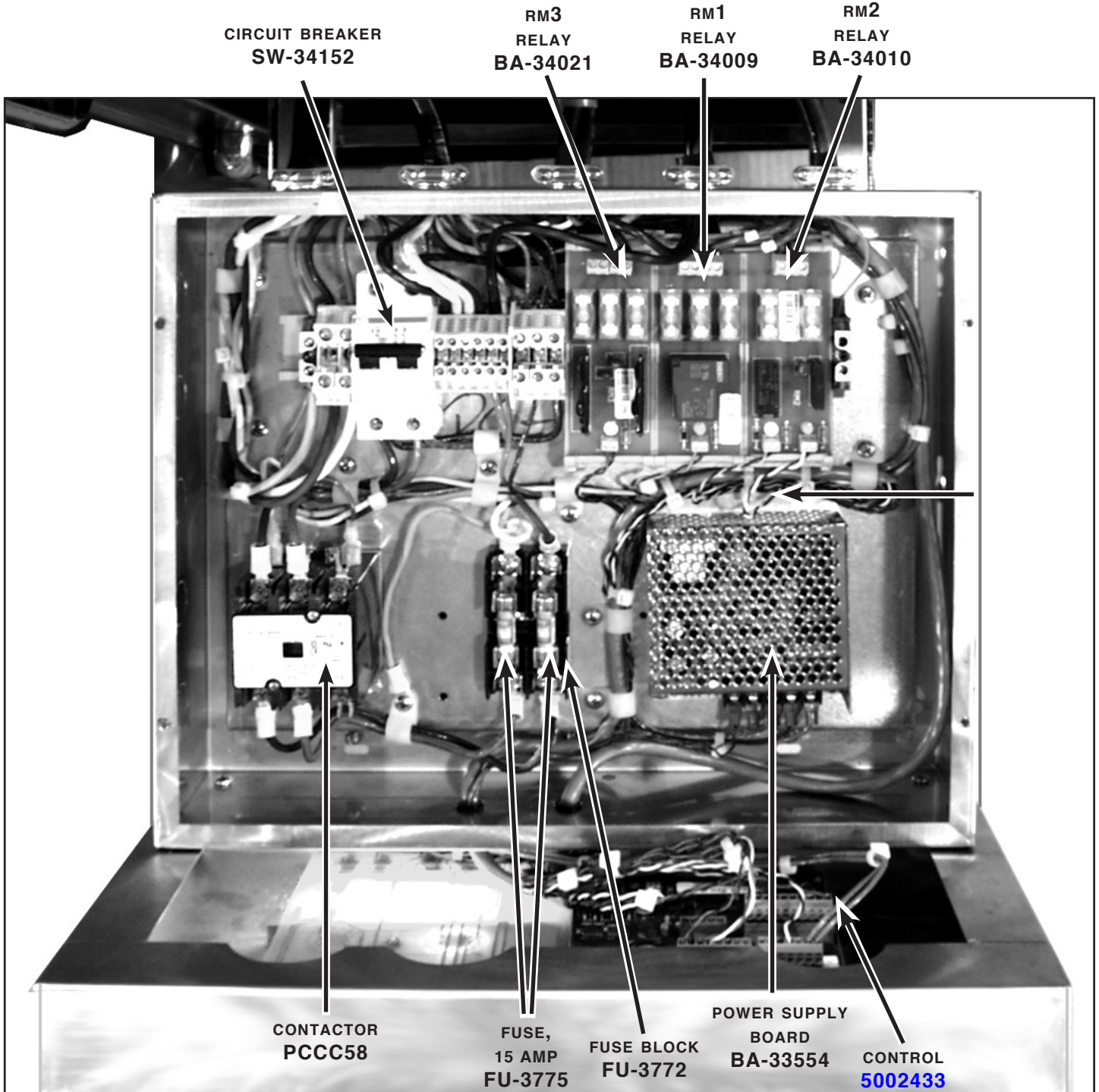

Part numbers and drawings are subject to change without notice.

SERVICE

MODEL: QC-20 COIL

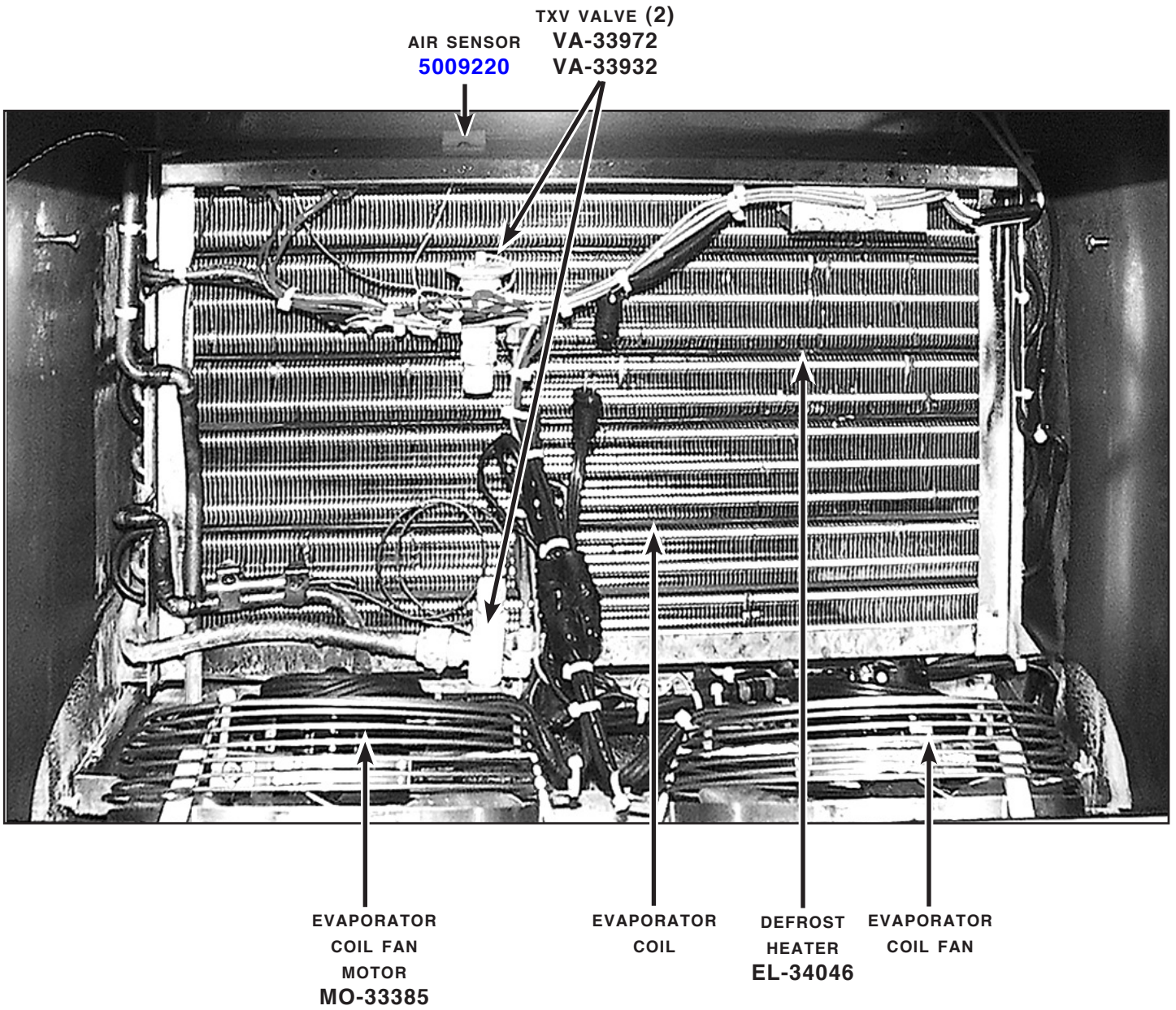

Part numbers and drawings are subject to change without notice.

SERVICE

MODEL: QC-20 CONDENSER

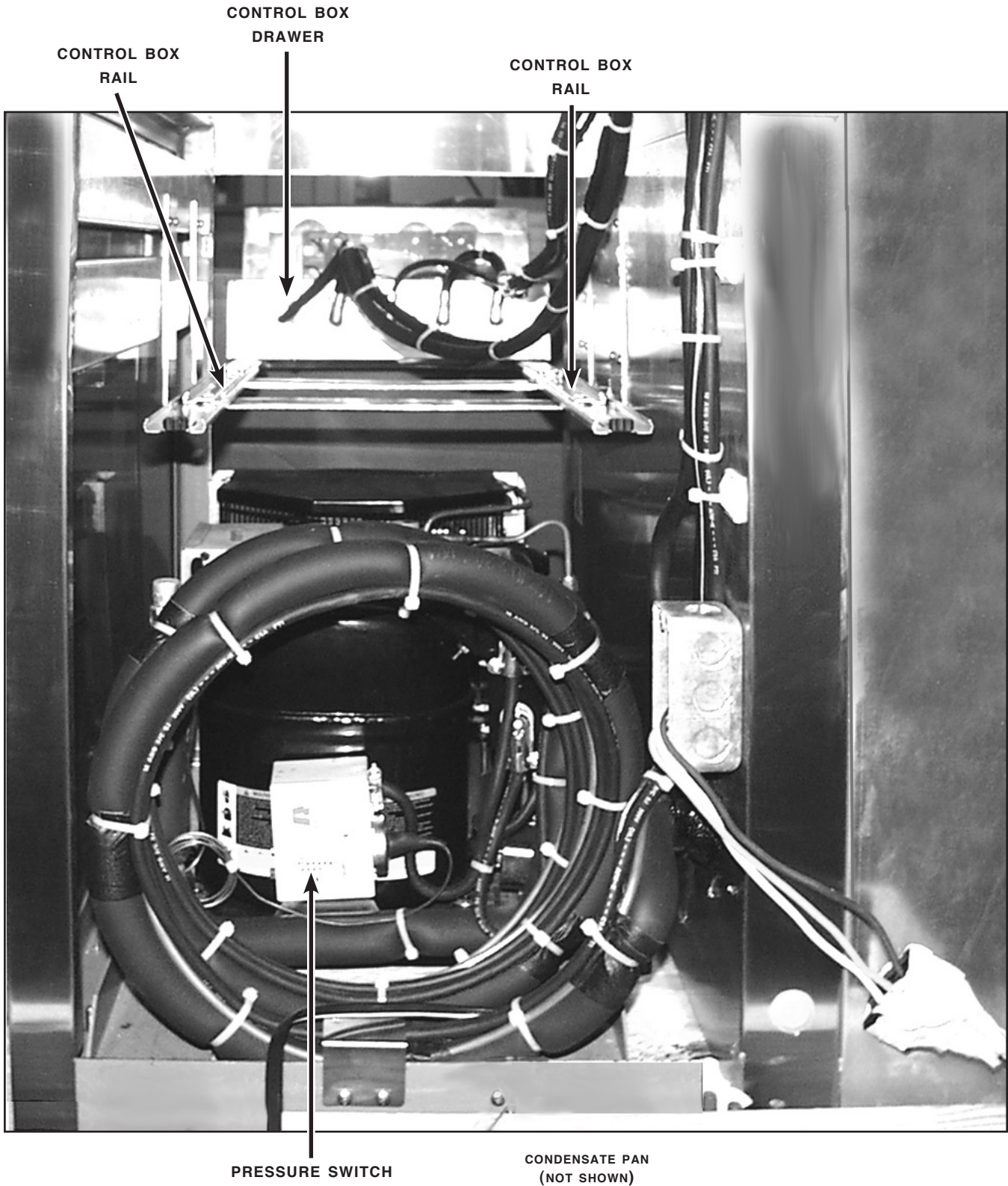

Part numbers and drawings are subject to change without notice.

SERVICE

MODEL: QC-40



Evaporator Coil

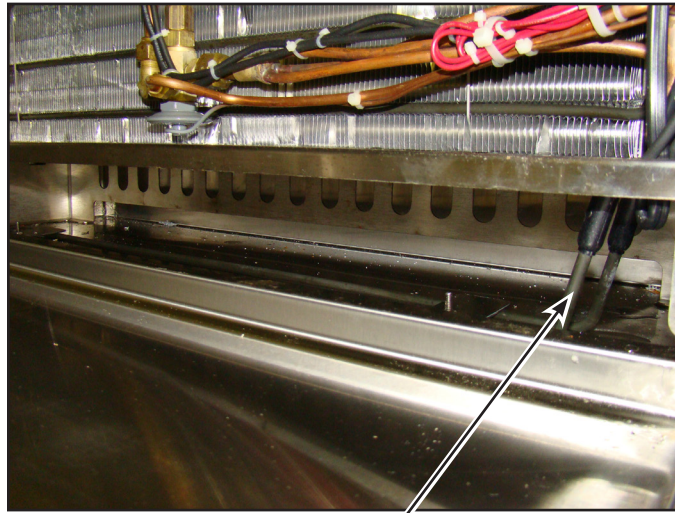

Drain Heater - CB-34199

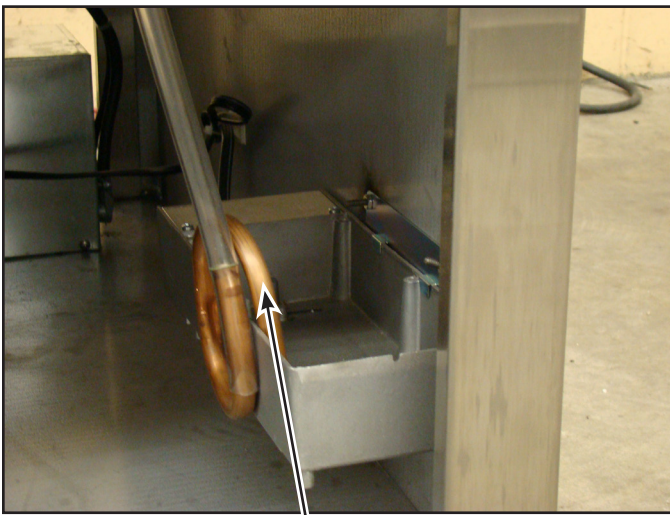

Drain Pan Heater - PN-27799

Defrost Heater - CB-34199



Coil Sensor - SN-33541

Defrost Terminator

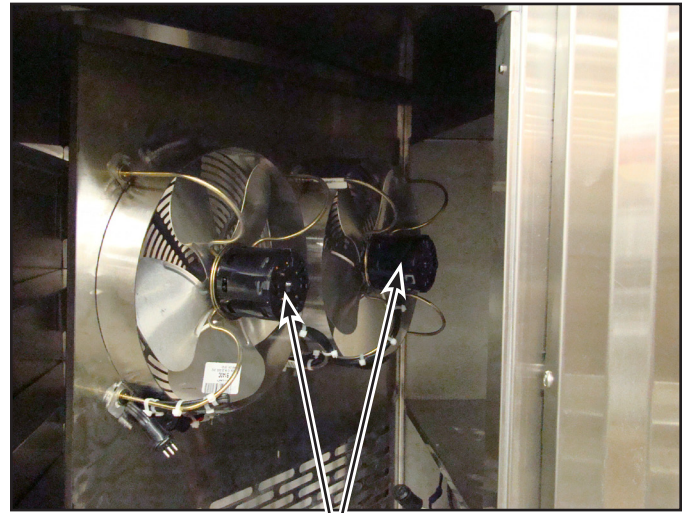

Evaporator Fan Motors - RWEM31

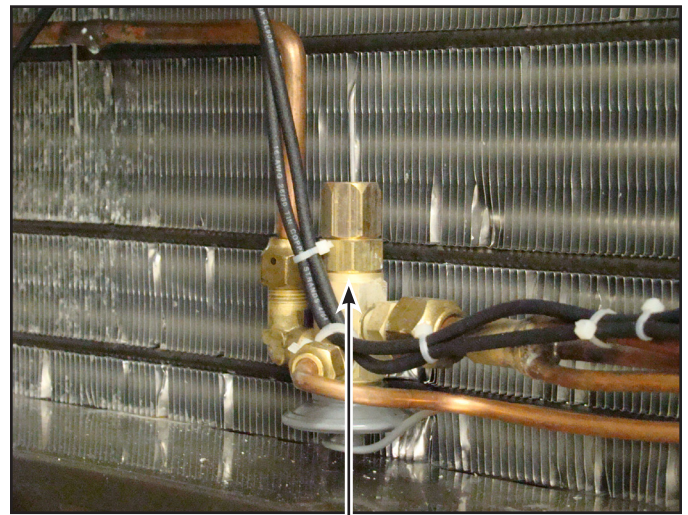

TXV Valve - RWEV42

Part numbers and drawings are subject to change without notice.

SERVICE

MODEL: QC-40 CONTROL

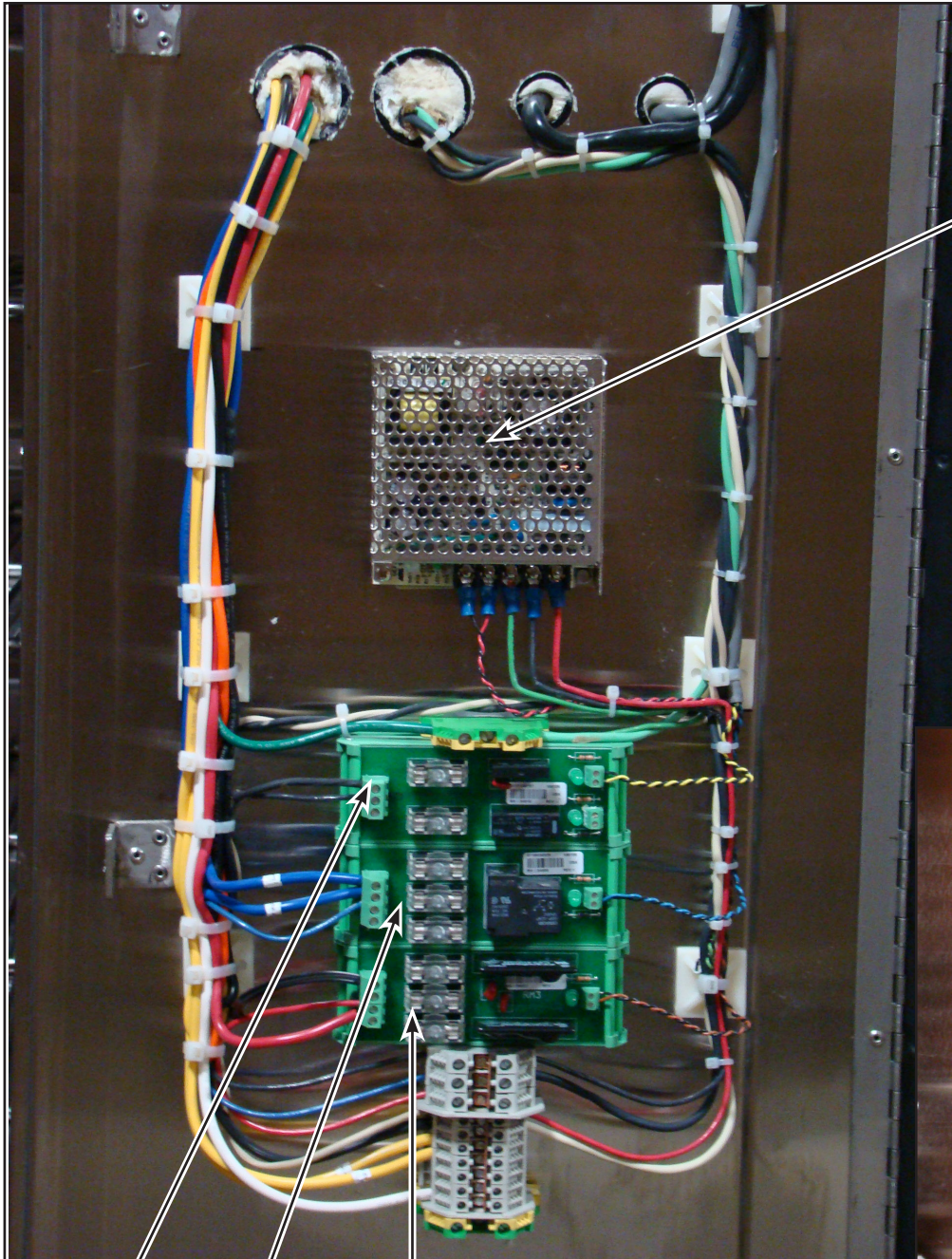

POWER SUPPLY BOARD
BA-33554

CONTROL BOARD
(QC-40/50/100)
5006727

RM2
RELAY
BA-34010

RM1
RELAY
BA-34009

RM3
RELAY
BA-34021

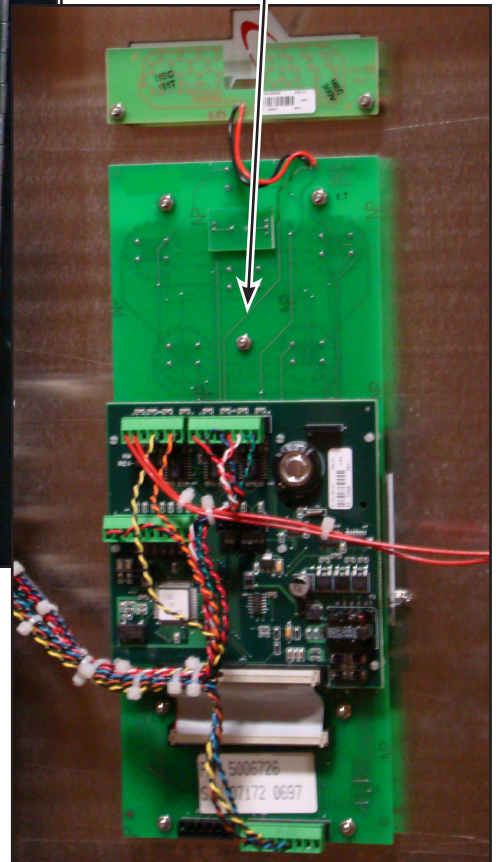

Part numbers and drawings are subject to change without notice.

SERVICE

MODEL: QC-50, QC-100 CONTROL

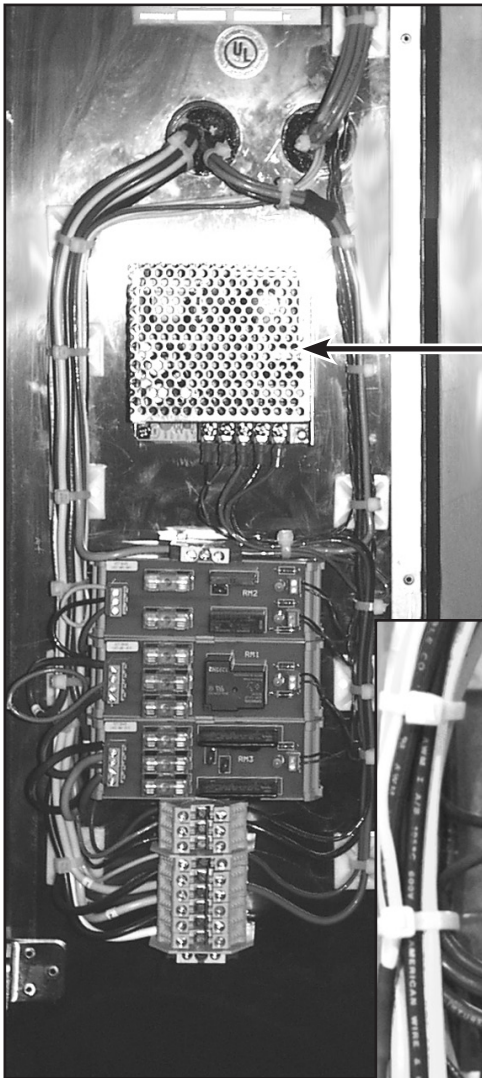

POWER SUPPLY BOARD
BA-33554

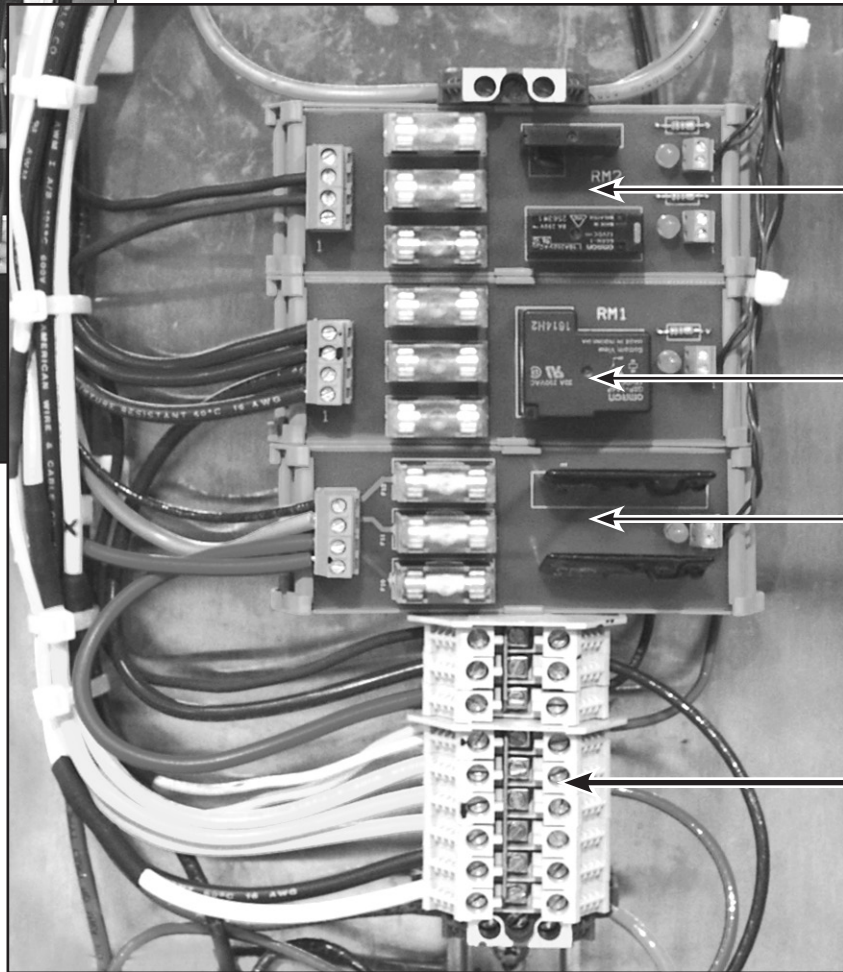

RM2 RELAY
BA-34010

RM1 RELAY
BA-34009

RM3 RELAY
BA-34021

TERMINAL
BLOCK

Part numbers and drawings are subject to change without notice.

SERVICE

MODEL: QC-100 COIL

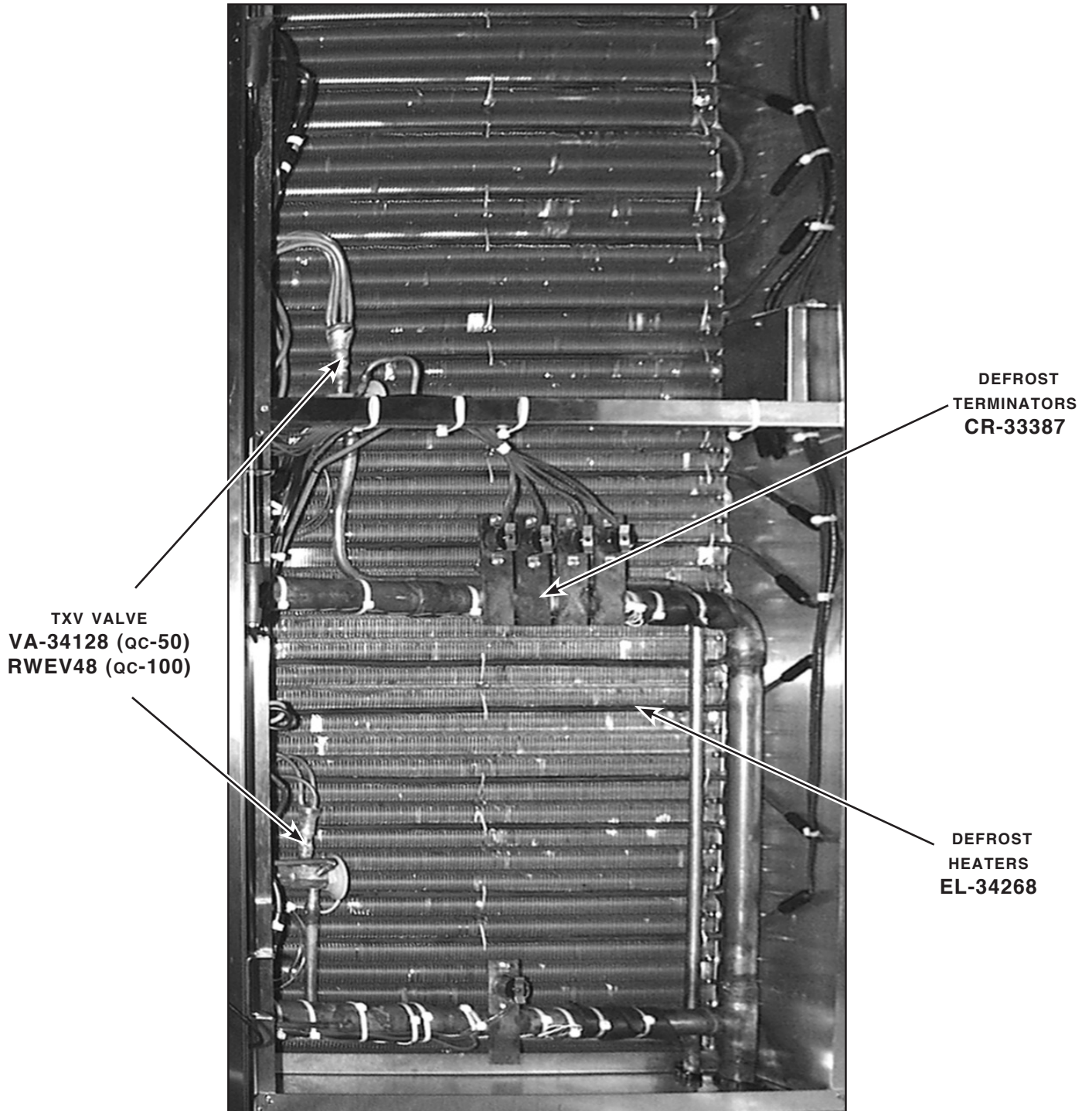

Part numbers and drawings are subject to change without notice.

SERVICE

MODEL: QC-50, QC-100 BREAKER

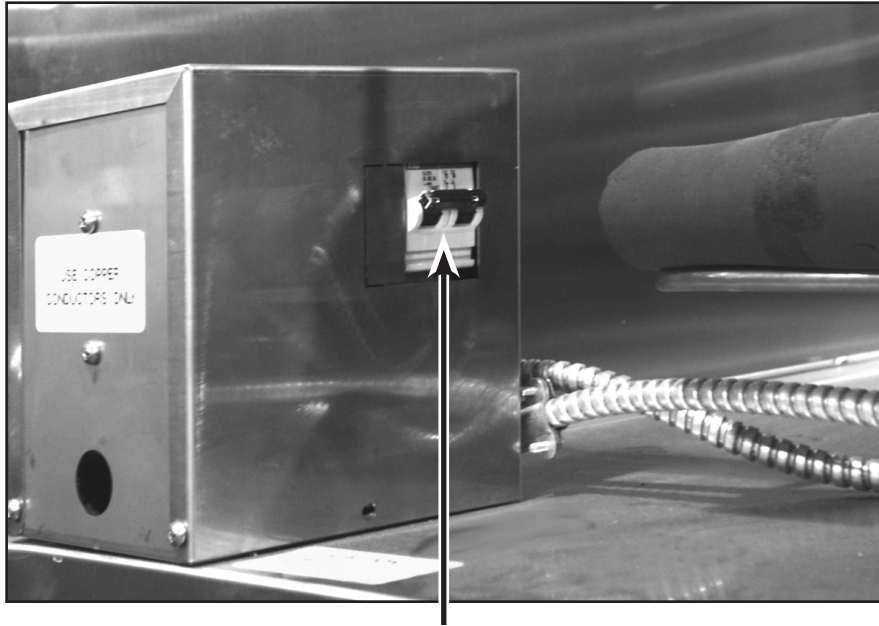

CIRCUIT BREAKER, 50 AMP
SW-34153 (QC-50)
SW-34154 (QC-100 - 208-240V, 1PH)
SW-34153 (QC-100 - 208-240V, 3PH)
SW-34152 (QC-100 - 380-415V, 3PH)

MODEL: QC-50, QC-100 FAN

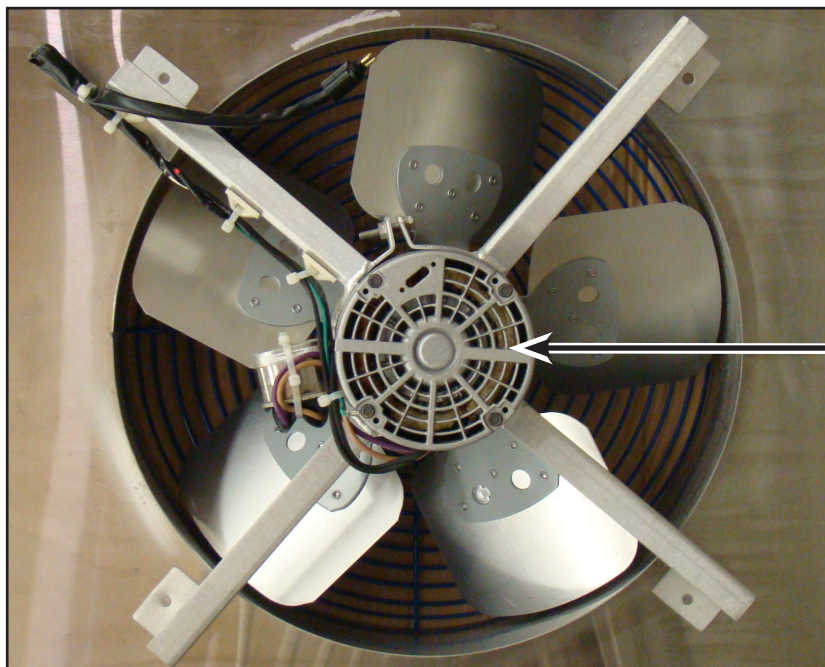

FAN
MO-27182

Part numbers and drawings are subject to change without notice.

SERVICE

MODEL: QC-50 Remote

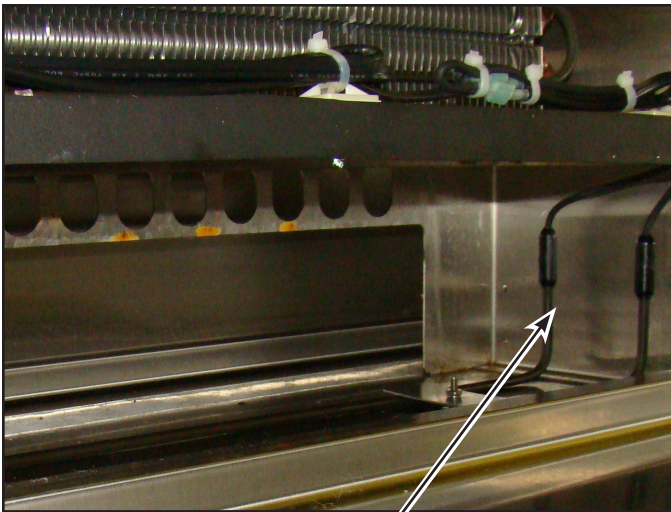
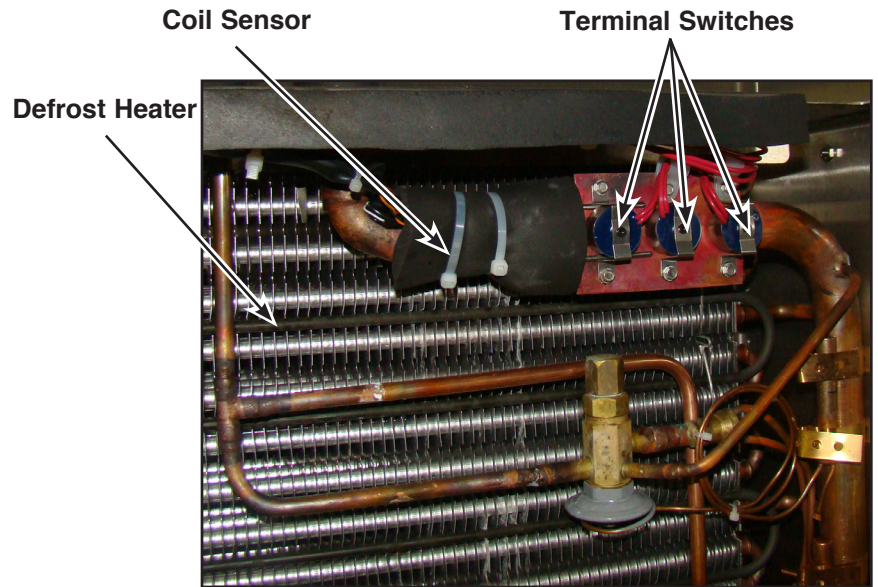
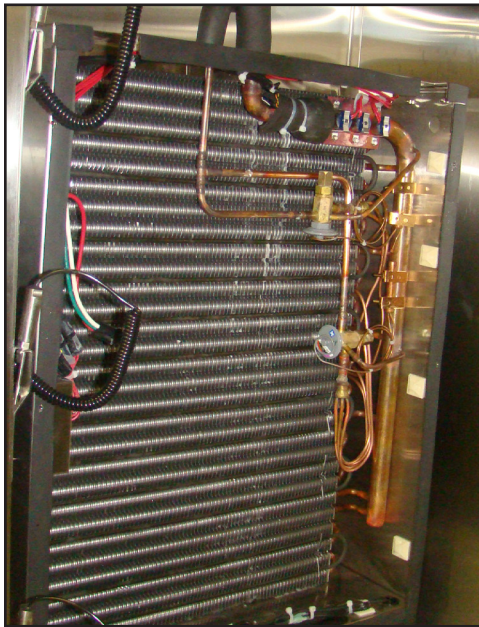

Drain Heater

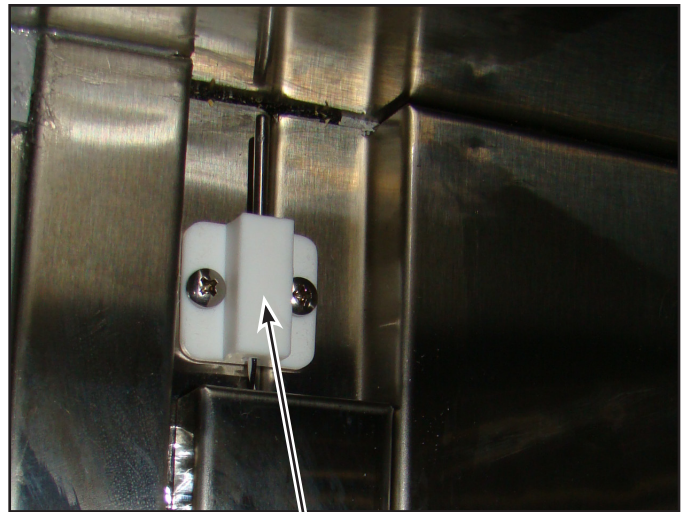

Cavity Air Sensor

Part numbers and drawings are subject to change without notice.

SERVICE

MODEL: QC-50, QC-100 REMOTE

Remote condensor connection



Circuit Breaker

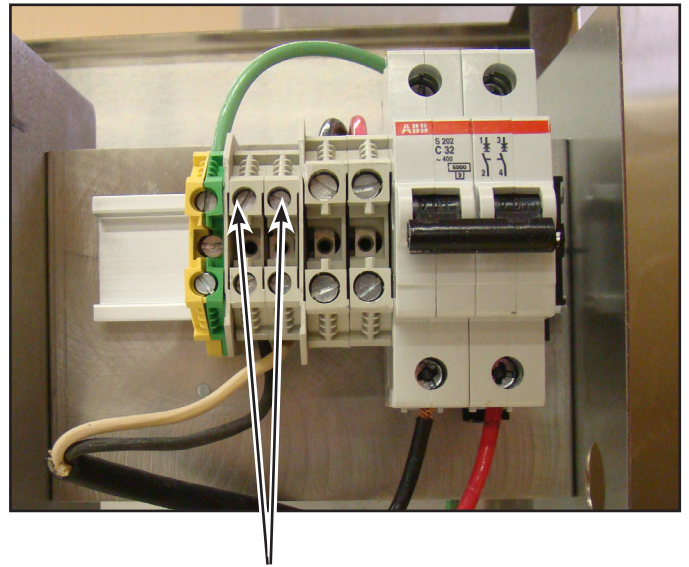

Connect wires to condensing unit solenoid here.

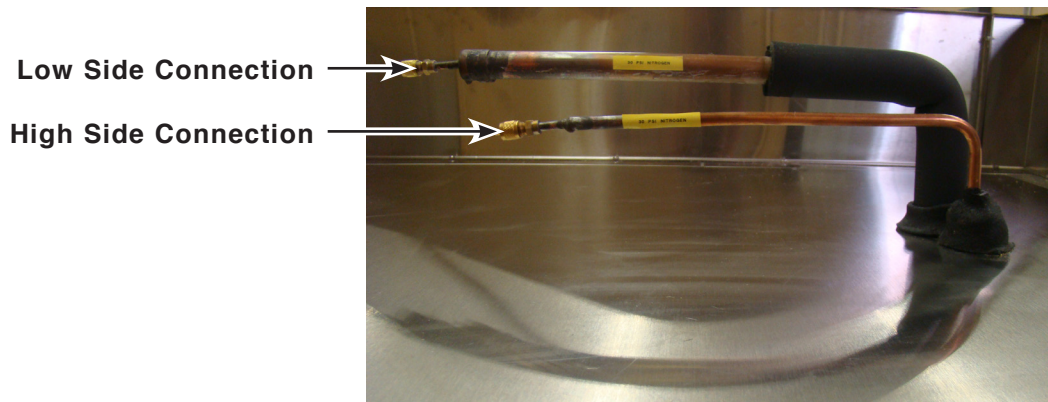

Low Side Connection

High Side Connection

Part numbers and drawings are subject to change without notice.

SERVICE

MODEL: QC-3 WIRING

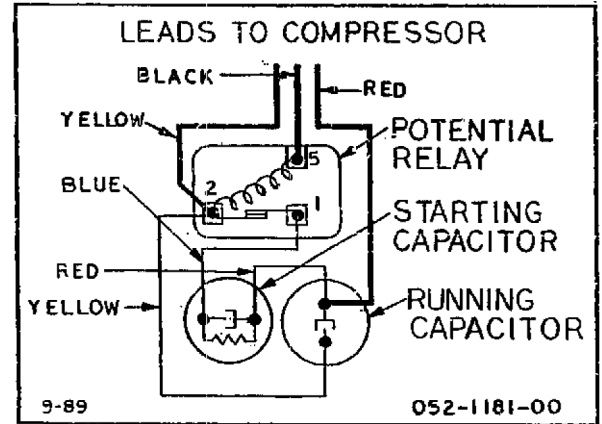
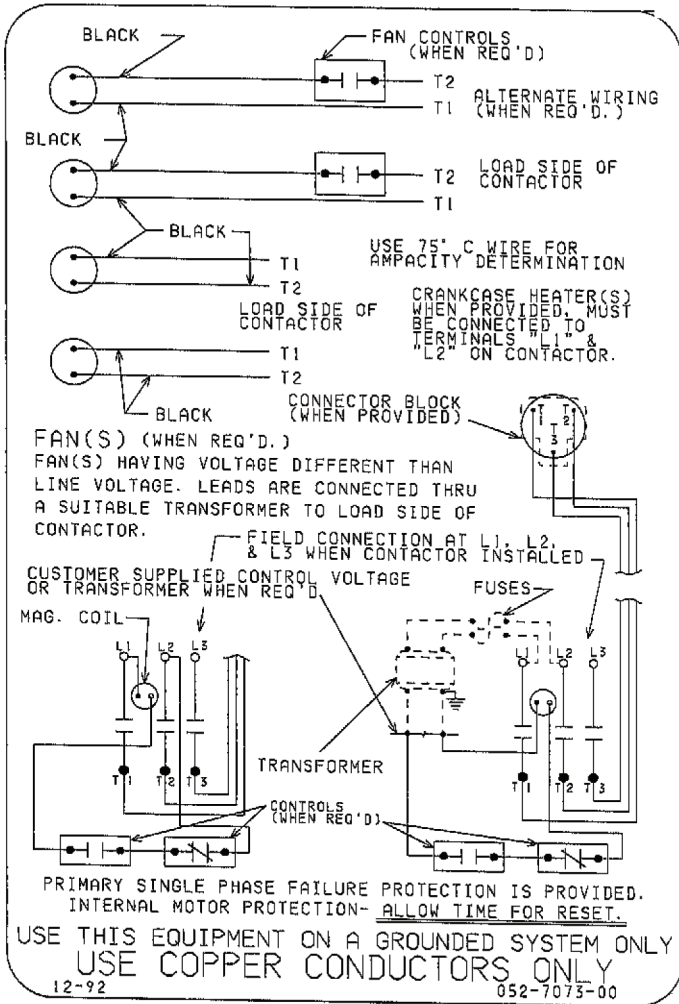

MODEL: QC-20 WIRING

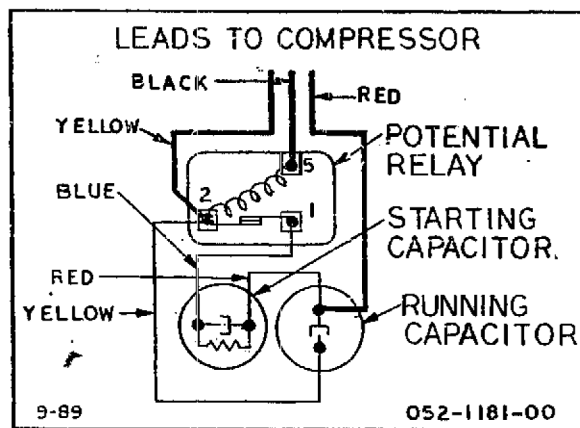

Part numbers and drawings are subject to change without notice.

SERVICE

MODEL: QC-40 WIRING

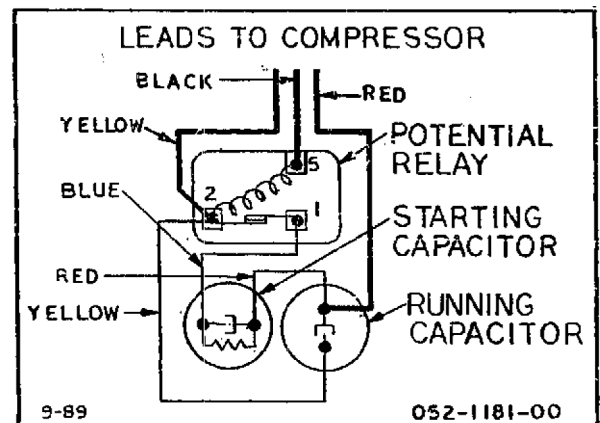
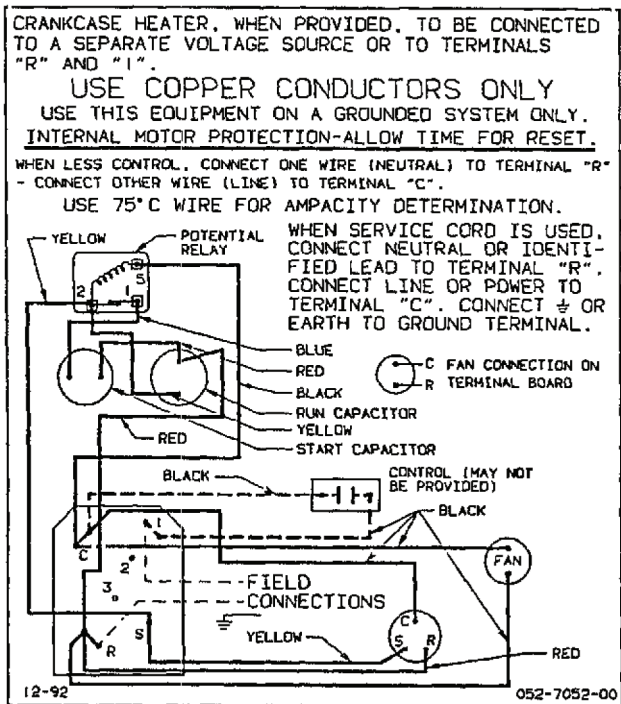
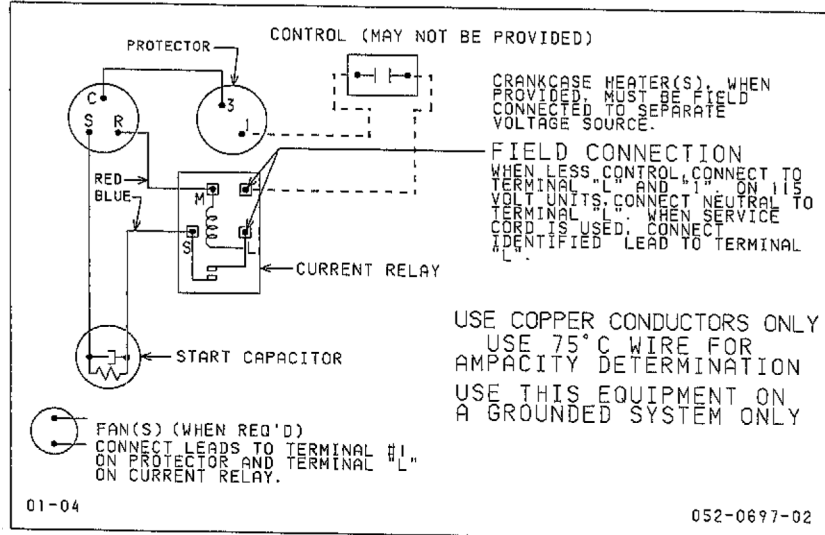

Part numbers and drawings are subject to change without notice.

SERVICE

MODEL: QC-50 WIRING

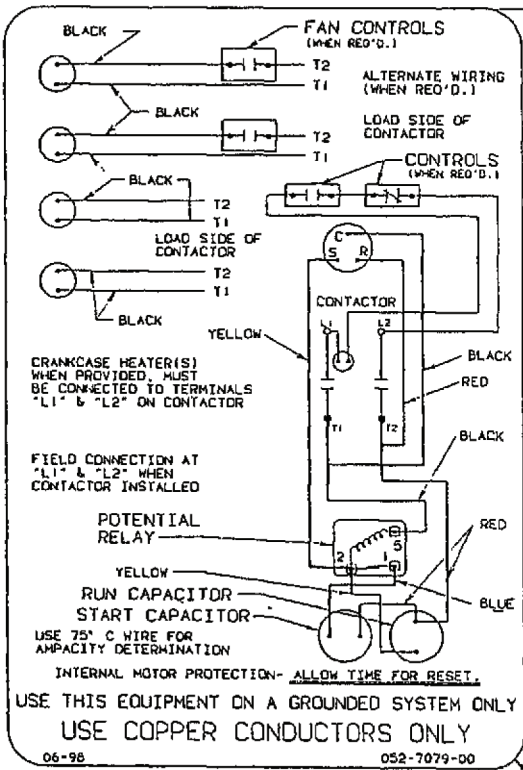

1PH

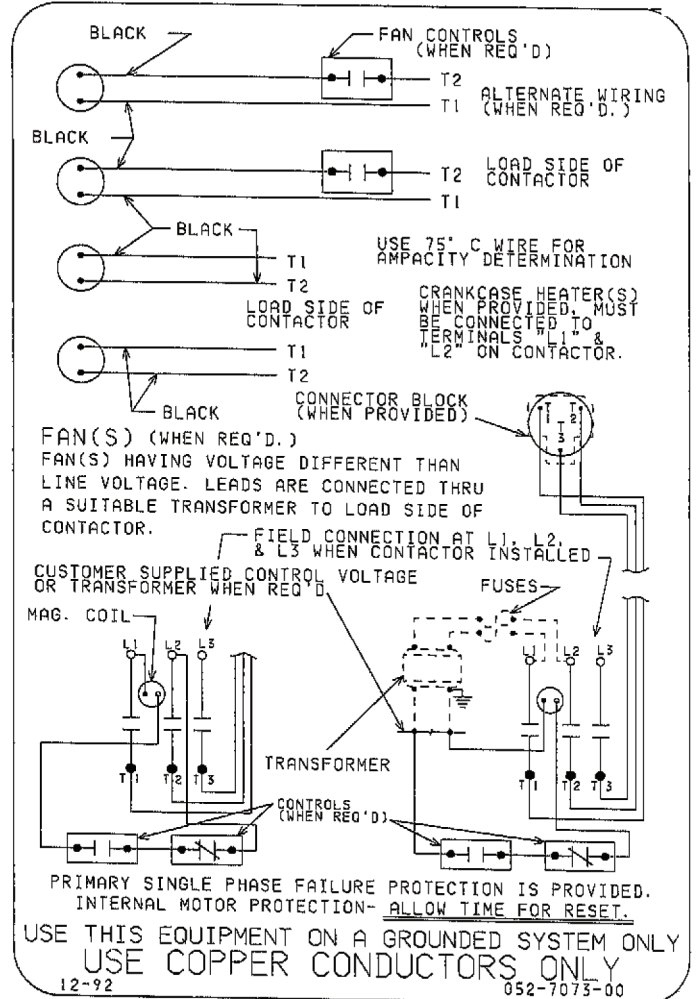

3PH

Part numbers and drawings are subject to change without notice.

SERVICE

MODEL: QC-100 WIRING

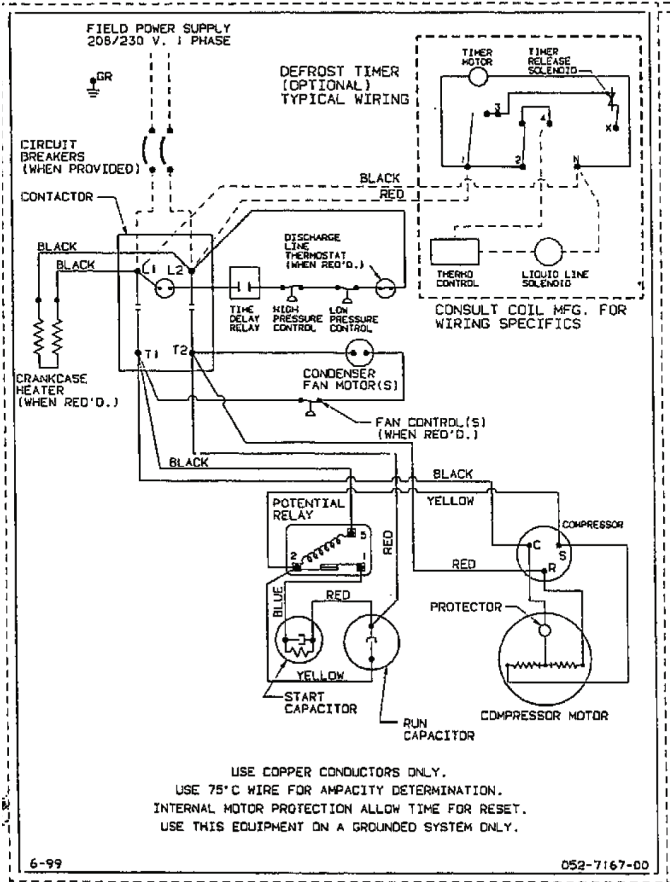

1PH

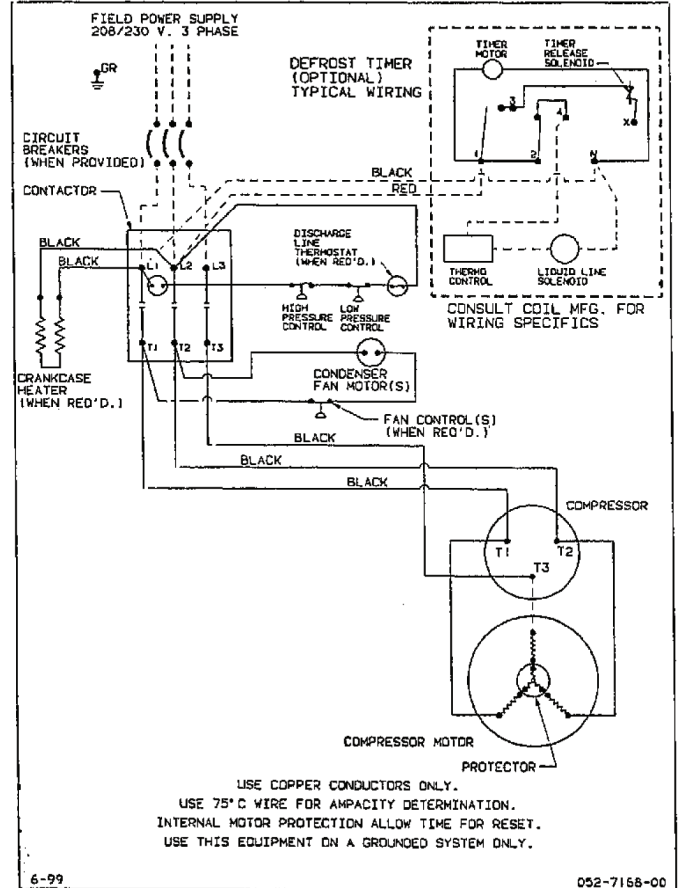

3PH

Part numbers and drawings are subject to change without notice.

TRANSPORTATION DAMAGE and CLAIMS



All Alto-Shaam equipment is sold F.O.B. shipping point, and when accepted by the carrier, such shipments become the property of the consignee.

Should damage occur in shipment, it is a matter between the carrier and the consignee. In such cases, the carrier is assumed to be responsible for the safe delivery of the merchandise, unless negligence can be established on the part of the shipper.

1. Make an immediate inspection while the equipment is still in the truck or immediately after it is moved to the receiving area. Do not wait until after the material is moved to a storage area.
2. Do not sign a delivery receipt or a freight bill until you have made a proper count and inspection of all merchandise received.
3. Note all damage to packages directly on the carrier's delivery receipt.
4. Make certain the driver signs this receipt. If he refuses to sign, make a notation of this refusal on the receipt.
5. If the driver refuses to allow inspection, write the following on the delivery receipt:
Driver refuses to allow inspection of containers for visible damage.
6. Telephone the carrier's office immediately upon finding damage, and request an inspection. Mail a written confirmation of the time, date, and the person called.
7. Save any packages and packing material for further inspection by the carrier.
8. Promptly file a written claim with the carrier and attach copies of all supporting paperwork.

We will continue our policy of assisting our customers in collecting claims which have been properly filed and actively pursued. We cannot, however, file any damage claims for you, assume the responsibility of any claims, or accept deductions in payment for such claims.

LIMITED WARRANTY

Alto-Shaam, Inc. warrants to the original purchaser only that any original part that is found to be defective in material or workmanship will, at Alto-Shaam's option, subject to provisions hereinafter stated, be replaced with a new or rebuilt part.

The parts warranty period is as follows:

For the refrigeration compressor on Alto-Shaam Quickchillers™, five (5) years from the date of installation.

For the heating element on Halo Heat® cook/hold ovens, as long as the original purchaser owns the oven.

For all other parts, one (1) year from the date of installation or fifteen (15) months from the shipping date, whichever occurs first.

The labor warranty period is one (1) year from the date of installation or fifteen (15) months from the shipping date, whichever occurs first.

Alto-Shaam will bear normal labor charges performed during standard business hours, excluding overtime, holiday rates or any additional fees.

To be valid, a warranty claim must be asserted during the applicable warranty period. This warranty is not transferable.

THIS WARRANTY DOES NOT APPLY TO:

1. Calibration.
2. Replacement of light bulbs, door gaskets, and/or the replacement of glass due to damage of any kind.
3. Equipment damage caused by accident, shipping, improper installation or alteration.
4. Equipment used under conditions of abuse, misuse, carelessness or abnormal conditions, including but not limited to, equipment subjected to harsh or inappropriate chemicals, including but not limited to, compounds containing chloride or quaternary salts, poor water quality, or equipment with missing or altered serial numbers.
5. Damage incurred as a direct result of poor water quality, inadequate maintenance of steam generators and/or surfaces affected by water quality. Water quality and required maintenance of steam generating equipment is the responsibility of the owner/operator.
6. Damage caused by use of any cleaning agent other than Alto-Shaam's Combitherm® Cleaner, including but not limited to damage due to chlorine or other harmful chemicals. **Use of Alto-Shaam's Combitherm® Cleaner on Combitherm® ovens is highly recommended.**
7. Any losses or damage resulting from malfunction, including loss of product or consequential or incidental damages of any kind.
8. Equipment modified in any manner from original model, substitution of parts other than factory authorized parts, removal of any parts including legs, or addition of any parts.

This warranty is exclusive and is in lieu of all other warranties, express or implied, including the implied warranties of merchantability and fitness for a particular purpose. In no event shall Alto-Shaam be liable for loss of use, loss of revenue or profit, or loss of product, or for any indirect, special, incidental, or consequential damages. No person except an officer of Alto-Shaam, Inc. is authorized to modify this warranty or to incur on behalf of Alto-Shaam any other obligation or liability in connection with Alto-Shaam equipment.

Effective 09/10



RECORD THE MODEL AND SERIAL NUMBER OF THE APPLIANCE FOR EASY REFERENCE.

ALWAYS REFER TO BOTH MODEL AND SERIAL NUMBER IN ANY CONTACT WITH ALTO-SHAAM REGARDING THIS APPLIANCE.

Model: _____ Date Installed: _____
Voltage: _____ Purchased From: _____
Serial Number: _____

W164 N9221 Water Street • P.O. Box 450 • Menomonee Falls, Wisconsin 53052-0450 • U.S.A.

PHONE: 262.251.3800 • 800.558-8744 USA/CANADA FAX: 262.251.7067 • 800.329.8744 U.S.A. ONLY

www.alto-shaam.com

PRINTED IN U.S.A.