

ALTO SHAAM®

OPERATION and CARE MANUAL



SC-30



MCD-30

MERCHANDISING DISPLAY CASE

**MODELS: MCD-30, MCD-30/P
SC-30**

HALO
HEAT

COOK/HOLD/SERVE SYSTEMS

24•7
Your Service Hotline
1-800-558-8744

W164 N9221 Water Street • P.O. Box 450 • Menomonee Falls, Wisconsin 53052-0450 U.S.A.

PHONE: 262.251.3800

800.558.8744 U.S.A./CANADA

FAX: 262.251.7067 • 800.329.8744 U.S.A. ONLY

262.251.1907 INTERNATIONAL

WEBSITE:

www.alto-shaam.com

UNPACKING and SET-UP

The Alto-Shaam Display Case has been thoroughly tested, checked for calibration, and inspected to insure only the highest quality unit is provided. When you receive your unit, check for any possible shipping damage and report it at once to the delivering carrier. See *Transportation Damage and Claims* section located in this manual.

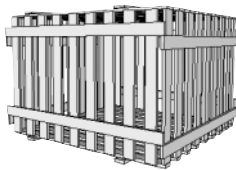

Save all the information and instructions packed inside the carton. Complete and return the warranty card to the factory as soon as possible to assure prompt service in the event of a warranty parts and labor claim.

NOTE: Any and all claims for warranty must include the full model number and serial number of the unit.

ELECTRICAL INSTALLATION

1. An identification tag is permanently mounted on the case.

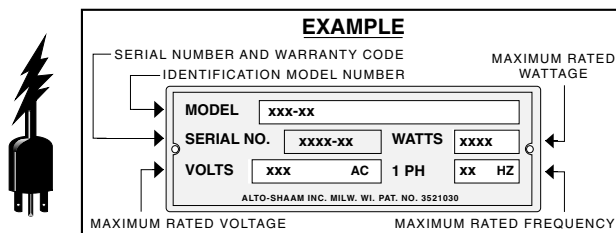

2. Plug the case into a properly grounded receptacle ONLY. Arcing will occur when connecting or disconnecting the display case unless all controls are in the "OFF" position.
3. If necessary, a proper receptacle or outlet configuration must be installed by a licensed electrician in accordance with applicable, local electrical codes.



**Ensure Power Source
Matches Voltage Stamped
on Unit Nameplate**

HEATING CHARACTERISTICS

The unit is equipped with a special, low-heat-density, heating cable. Through the Halo Heat concept, the heating cable is mounted against the top surface of the unit to provide an evenly applied, thermostatically controlled, heat source. Through even heat application, food quality is maintained up as much as several hours.

START-UP

Install the legs that are supplied with the unit. Before operating the case, clean the interior and exterior of the unit with a damp cloth and mild soap solution. Remove all detachable items and clean separately. Rinse carefully. Clean the glass with a standard commercial glass cleaner.

This unit should NOT be installed in any area where it may be affected by steam, grease, dripping water, high temperatures or any other severely adverse conditions. Do not install directly adjacent to heat producing equipment.

OPERATIONAL PROCEDURES

1. **DO NOT ADD WATER TO THE DISPLAY CASE.** Halo Heat display cases maintain a constant but gentle temperature and eliminate much of the moisture loss associated with conventional display cases. Because of this gentle heat, it is not necessary to add water to the unit. As a matter of fact, **adding water is not recommended** since water will accelerate the deterioration of the product, and may damage the unit.
2. **FOR MODEL MCD-30: PLACE DIVIDER BARS AND PANS (OR PAN GRID) INTO UNIT.** The divider bars (or pan grids) must be used to close all gaps between pans and the edges of the display case. If these gaps are not closed, the heat can be pulled out of the bottom of the case into the display area. As a consequence, heat distribution will be uneven and uniform temperature will be difficult to hold. Refer to pan layout diagrams for different types of pan accommodations that located in this manual. Note that the pan grid is used in the self-serve model only.
3. **TURN DISPLAY LIGHTS "ON" AND SET THE THERMOSTAT AT NUMBER "10" TO PREHEAT.** An indicator light will illuminate when the thermostat is turned 'ON'. The indicator will remain lit as long as the unit is preheating or calling for heat. The unit should be preheated at the number 10 setting for a minimum of 25 minutes before loading the merchandiser with food. When preheating is completed, or whenever the unit reaches any temperature set by the operator between 1 and 10, the indicator light will go "OUT".
4. **LOAD HOT FOODS INTO THE DISPLAY CASE.** Be certain **only hot food** is transferred into the case. Before loading food, use a pocket-type meat thermometer to make certain all products have reached an internal temperature of 140° to 160° F. (60° to 71°C). If any food product is not at proper serving temperature, bring the product within the correct temperature range. **Be certain only hot PREPACKAGED foods in heat tested containers are used in the self-service section of the display case.**
5. **RESET THERMOSTAT AS NEEDED.** After all products are loaded into the display case and the doors are closed, reset the thermostat to the number "8" setting. *This will not necessarily be the final setting.* Since proper temperature range depends on the type of products and the quantities being held, it is necessary to periodically use a pocket thermometer to check each item to make certain the correct temperatures are being maintained. Proper temperature range is between 140° and 160°F (60° and 71°C). Normally, this will require a thermostat setting of between number "6" and "8," although a higher or lower setting may sometimes be required.
6. **SERVE FRESH HOT FOOD.** Keep hot foods looking fresh. Occasionally stir or rotate foods as needed. Serve products in the proper package or container. Keep display case doors closed after serving. Wipe spills immediately to assure maximum eye appeal and ease end of the day cleanup.

CARE and CLEANING

The cleanliness and appearance of this unit will contribute considerably to operating efficiency and savory, appetizing food. Good equipment that is kept clean works better and lasts longer.



CLEAN THE DISPLAY CASE DAILY

1. Disconnect the unit from the power source. Let unit cool.
2. Remove all detachable items such as pan separator bars, pan grid, etc. Clean these separately.
3. Clean the interior metal surfaces of the cabinet with a damp cloth and any good alkaline or alkaline chlorinated based commercial detergent or grease solvent at the recommended strength. Use a plastic scouring pad or oven cleaner for difficult areas. Avoid the use of abrasive cleaning compounds, chloride based cleaners, or cleaners containing quaternary salts. Rinse well to remove all residue and wipe dry.
4. Clean all window areas with a standard commercial glass cleaner.
5. To help maintain the protective film coating on polished steel, clean the exterior of the cabinet with a cleaner recommended for stainless steel surfaces. Spray the cleaning agent on a clean cloth and wipe with the grain of the stainless steel.



NOTE: Never use hydrochloric acid (muriatic acid) on stainless steel.

Always follow appropriate state and local health (hygiene) regulations regarding all applicable cleaning and sanitation requirements for equipment.

At no time should the inside or outside of the cabinet be washed down, flooded with water or liquid solution.

Do not use water jet to clean.
NEVER STEAM CLEAN.
Severe damage or electrical hazard could result, voiding the warranty.



SAFETY ALERT

This units performance has been optimized using the factory provided bulbs. These bulbs should be replaced with an exact replacement or with a factory recommended replacement. These bulbs have been treated to resist breakage and must be replaced with similarly treated bulbs in order to maintain compliance with NSF standards.

CAUTION

CAUTION

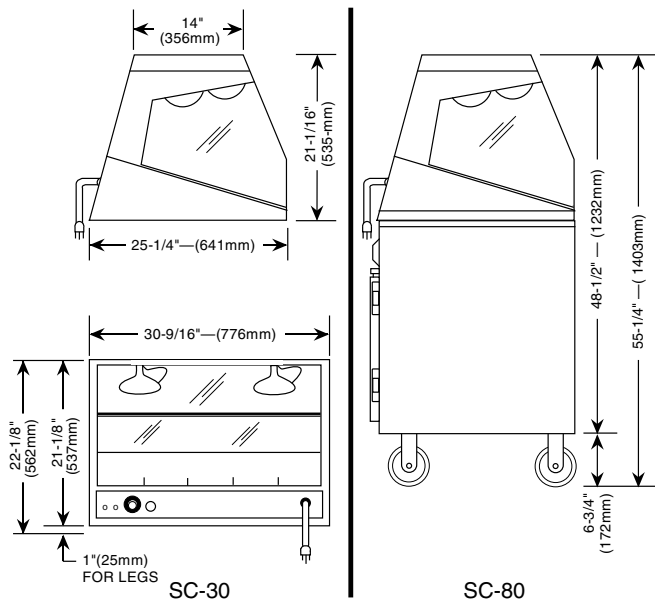

OUTSIDE DIMENSIONS

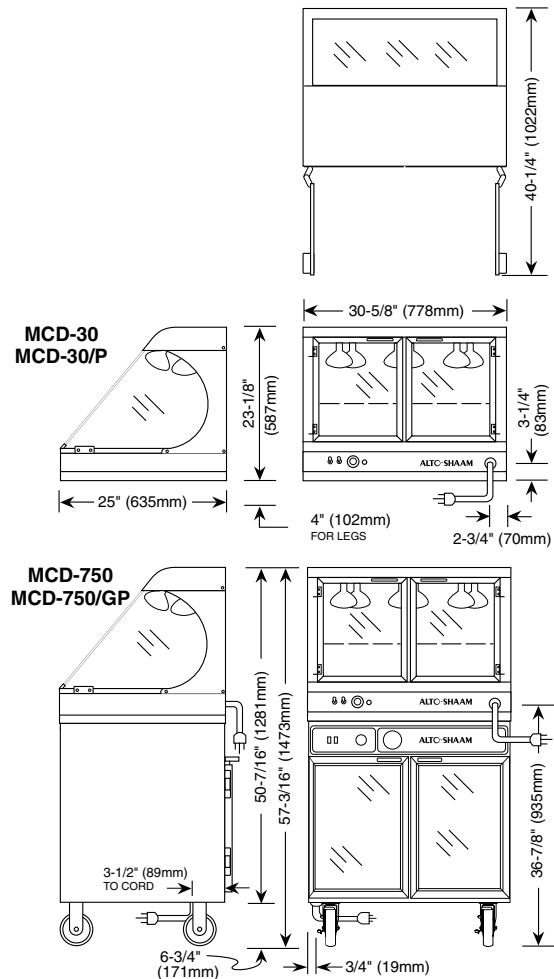

SANITATION GUIDELINES

Food flavor and aroma are usually so closely related that it is difficult, if not impossible, to separate them. There is also an important, inseparable relationship between cleanliness and food flavor. Cleanliness, top operating efficiency, and appearance of equipment contribute considerably to savory, appetizing foods. Good equipment that is kept clean, works better and lasts longer.

Most food imparts its own particular aroma and many foods also absorb existing odors. Unfortunately, during this absorption, there is no distinction between GOOD and BAD odors. The majority of objectionable flavors and odors troubling food service operations are caused by bacteria growth. Sourness, rancidity, mustiness, stale or other OFF flavors are usually the result of germ activity.

The easiest way to insure full, natural food flavor is through comprehensive cleanliness. This means good control of both visible soil (dirt) and invisible soil (germs). A thorough approach to sanitation will provide essential cleanliness. It will assure an attractive appearance of equipment, along with maximum efficiency and utility. More importantly, a good sanitation program provides one of the key elements in the prevention of food-borne illnesses.

A controlled holding environment for prepared foods is just one of the important factors involved in the prevention of food-borne illnesses. Temperature monitoring and control during receiving, storage, preparation, and the service of foods are of equal importance.

The most accurate method of measuring safe temperatures of both hot and cold foods is by internal product

INTERNAL FOOD PRODUCT TEMPERATURES		
HOT FOODS		
DANGER ZONE	40° TO 140°F	(4° TO 60°C)
CRITICAL ZONE	70° TO 120°F	(21° TO 49°C)
SAFE ZONE	140° TO 165°F	(60° TO 74°C)
COLD FOODS		
DANGER ZONE	ABOVE 40°F	(ABOVE 4°C)
SAFE ZONE	36°F TO 40°F	(2°C TO 4°C)
FROZEN FOODS		
DANGER ZONE	ABOVE 32°F	(ABOVE 0°C)
CRITICAL ZONE	0° TO 32°F	(-18° TO 0°C)
SAFE ZONE	0°F OR BELOW	(-18°C OR BELOW)

temperature. A quality thermometer is an effective tool for this purpose, and should be routinely used on all products that require holding at a specific temperature.

A comprehensive sanitation program should focus on the training of staff in basic sanitation procedures. This includes personal hygiene, proper handling of raw foods, cooking to a safe internal product temperature, and the routine monitoring of internal temperatures from receiving through service.

Most food-borne illnesses can be prevented through proper temperature control and a comprehensive program of sanitation. Both these factors are important to build quality service as the foundation of customer satisfaction. Safe food handling practices to prevent food-borne illness is of critical importance to the health and safety of our customers. HACCP, an acronym for Hazard Analysis (at) Critical Control Points, is a quality control program of operating procedures to assure food integrity, quality, and safety. Taking steps necessary to augment food safety practices are both cost effective and relatively simple. While HACCP guidelines go far beyond the scope of this manual, additional information is available by contacting the USDA/FDA Food-borne Illness Education Information Center at (301)504-6803.

GENERAL HOLDING GUIDELINES

Chefs, cooks and other specialized food service personnel employ varied methods of cooking. Proper holding temperatures for a specific food product must be based on the moisture content of the product, product density, volume, and proper serving temperatures. Safe holding temperatures must also be correlated with palatability in determining the length of holding time for a specific product.

Halo Heat maintains the maximum amount of product moisture content without the addition of water, water vapor, or steam. Maintaining maximum natural product moisture preserves the natural flavor of the product and provides a more genuine taste. In addition to product moisture retention, the gentle properties of Halo Heat maintain a consistent temperature throughout the unit without the necessity of a heat distribution fan, thereby preventing further moisture loss due to evaporation or dehydration.

In an enclosed holding environment, too much moisture content is a condition which can be relieved. A product achieving extremely high temperatures in preparation must be allowed to decrease in temperature before being placed in a controlled holding atmosphere. If the product is not allowed to decrease in temperature, excessive condensation will form increasing the moisture content on the outside of the product.

Most Halo Heat Holding Equipment is provided with a thermostat control between 60° and 200°F (16° to 93°C). If the unit is equipped with vents, close the vents for moist holding and open the vents for crisp holding.

If the unit is equipped with a thermostat indicating a range of between 1 and 10, use a metal-stemmed indicating thermometer to measure the internal temperature of the product(s) being held. Adjust the thermostat setting to achieve the best overall setting based on internal product temperature.

HOLDING TEMPERATURE RANGE		
	FAHRENHEIT	CELSIUS
MEAT		
BEEF ROAST — Rare	140°F	60°C
BEEF ROAST — Med/Well Done	160°F	71°C
BEEF BRISKET	160° — 175°F	71° — 79°C
CORN BEEF	160° — 175°F	71° — 79°C
PASTRAMI	160° — 175°F	71° — 79°C
PRIME RIB — Rare	140°F	60°C
STEAKS — Broiled/Fried	140° — 160°F	60° — 71°C
RIBS — Beef or Pork	160°F	71°C
VEAL	160° — 175°F	71° — 79°C
HAM	160° — 175°F	71° — 79°C
PORK	160° — 175°F	71° — 79°C
LAMB	160° — 175°F	71° — 79°C
POULTRY		
CHICKEN — Fried/Baked	160° — 175°F	71° — 79°C
DUCK	160° — 175°F	71° — 79°C
TURKEY	160° — 175°F	71° — 79°C
GENERAL	160° — 175°F	71° — 79°C
FISH/SEAFOOD		
FISH — Baked/Fried	160° — 175°F	71° — 79°C
LOBSTER	160° — 175°F	71° — 79°C
SHRIMP — Fried	160° — 175°F	71° — 79°C
BAKED GOODS		
BREADS/ROLLS	120° — 140°F	49° — 60°C
MISCELLANEOUS		
CASSEROLES	160° — 175°F	71° — 79°C
DOUGH — Proofing	80° — 100°F	27° — 38°C
EGGS — Fried	150° — 160°F	66° — 71°C
FROZEN ENTREES	160° — 175°F	71° — 79°C
HORS D'OEUVRES	160° — 180°F	71° — 82°C
PASTA	160° — 180°F	71° — 82°C
PIZZA	160° — 180°F	71° — 82°C
POTATOES	180°F	82°C
PLATED MEALS	180°F	82°C
SAUCES	140° — 200°F	60° — 93°C
SOUP	140° — 200°F	60° — 93°C
VEGETABLES	160° — 175°F	71° — 79°C

THE HOLDING TEMPERATURES LISTED ARE SUGGESTED GUIDELINES ONLY.

PAN CONFIGURATIONS

MCD-30

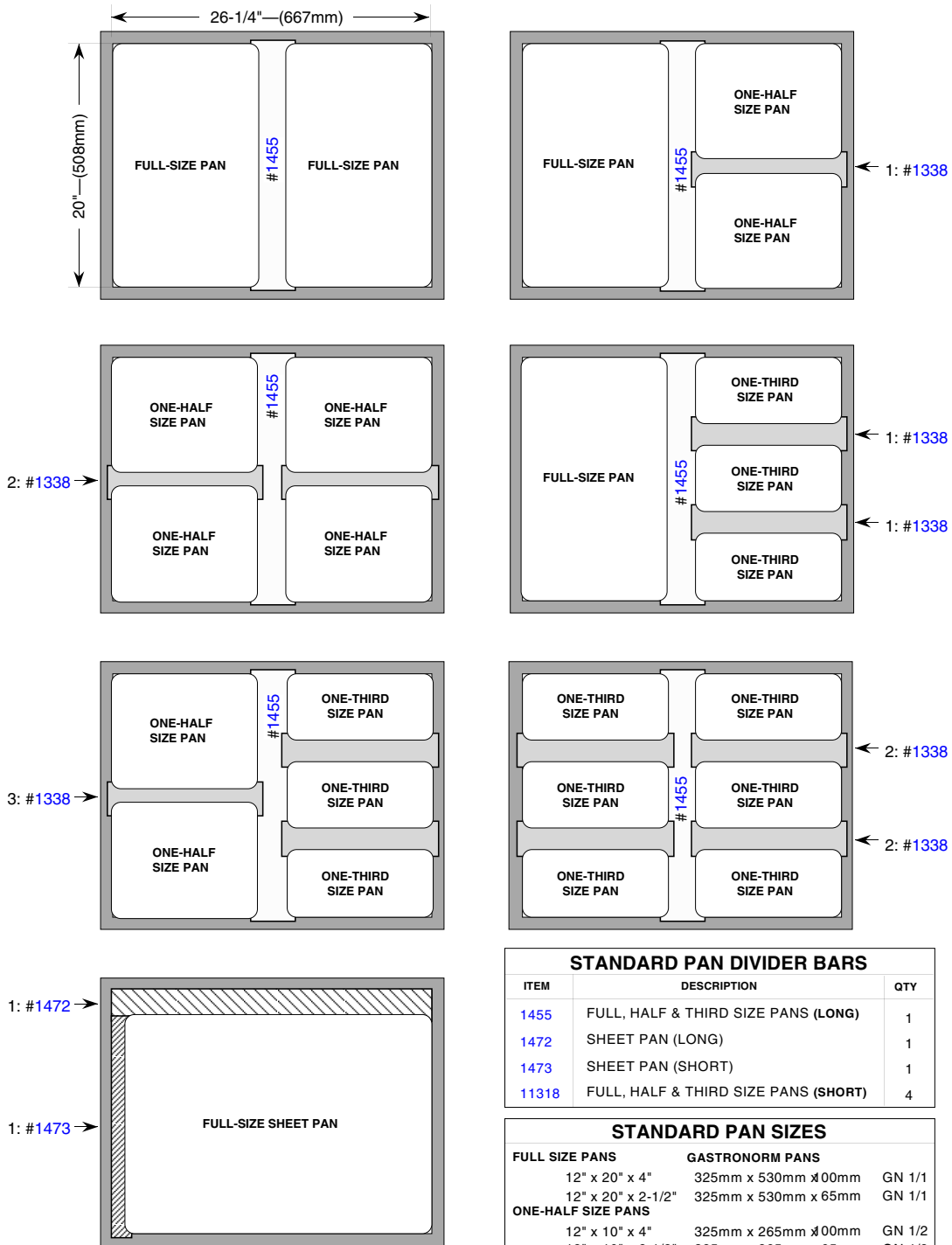

STANDARD PAN DIVIDER BARS		
ITEM	DESCRIPTION	QTY
1455	FULL, HALF & THIRD SIZE PANS (LONG)	1
1472	SHEET PAN (LONG)	1
1473	SHEET PAN (SHORT)	1
11318	FULL, HALF & THIRD SIZE PANS (SHORT)	4

STANDARD PAN SIZES		
FULL SIZE PANS	GASTRONORM PANS	
12" x 20" x 4"	325mm x 530mm x 00mm	GN 1/1
12" x 20" x 2-1/2"	325mm x 530mm x 65mm	GN 1/1
ONE-HALF SIZE PANS		
12" x 10" x 4"	325mm x 265mm x 00mm	GN 1/2
12" x 10" x 2-1/2"	325mm x 265mm x 65mm	GN 1/2
ONE-THIRD SIZE PANS		
12" x 6" x 4"	325mm x 176mm x 00mm	GN 1/3
12" x 6" x 2-1/2"	325mm x 176mm x 65mm	GN 1/3
FULL-SIZE SHEET PANS		
18" x 26" x 1"	N/A	

MCD-30 • CUSTOMER HEAT GUARD INSTALLATION INSTRUCTIONS

MCD-30

1. Remove the stainless steel Front Guard located on the lower front of the case. Caution should be used following removal of the Guard since the glass is only resting in the glass bracket groove, and it is not properly secured to the case. Do not bump or move the glass off the bracket groove.
2. Remove the two (2) Glass Brackets. Place the heat guard on the unit, aligning the guard with the four (4) bracket holes. Place the Glass Brackets on top of the Heat Guard, aligned with the bracket holes and resecure with the Glass Bracket Mounting Screws.
3. Carefully replace front glass on the unit. Align the Front Guard with the holes in the bracket. Secure the Guard in place with (8) 32 x 1/2" screws provided and tighten securely.

CAUTION: DO NOT OVER TIGHTEN! DO NOT USE THREAD TIGHTENING COMPOUNDS SUCH AS "LOCKTIGHT".

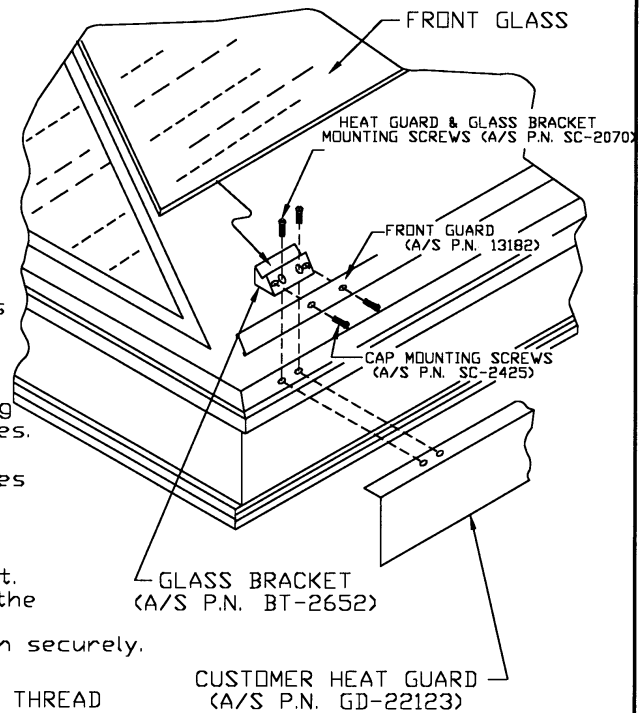

Q:\SM\MCD30GRD.DWG

REV: 9/2/98 JMM

MCD-30/P

1. Position the Customer Heat Guard at the opening between the front glass and the base of the case.
2. Exert slight pressure on the top of the Customer Heat Guard until it snaps over the base and secures in place.

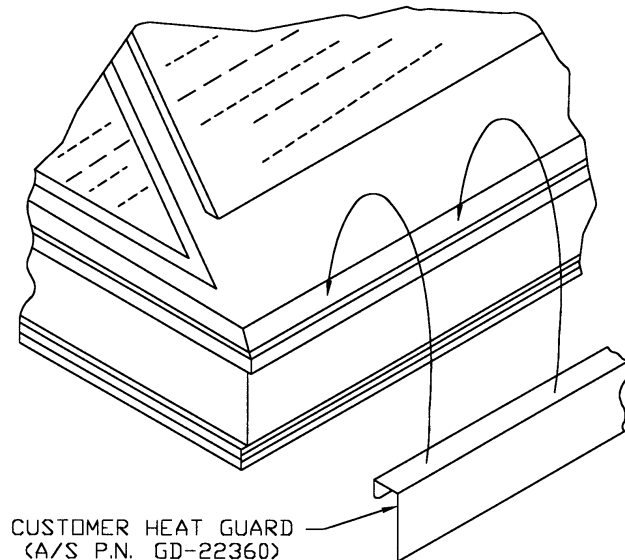

MCD30GRD 03-08-94 RS

SERVICE VIEW PARTS LISTS

MCD-30				MCD-30/P			
5/3/00	PART DESCRIPTION	UNIT QUANTITY	ALTO-SHAAM PART NUMBER	5/3/00	PART DESCRIPTION	UNIT QUANTITY	ALTO-SHAAM PART NUMBER
1.	LEGS	4	LG-2044	1.	LEGS	4	LG-2044
2.	BOTTOM	1	4451	2.	BOTTOM	1	4451
3.	BOTTOM MOUNTING SCREWS	12	SC-2425	3.	BOTTOM MOUNTING SCREWS	12	SC-2425
4.	INSULATION: 24" x 29" (610mm x 737mm)	1	IN-22364	4.	INSULATION: 24" x 29" (610mm x 737mm)	1	IN-22364
5.	CABLE CONNECTION HARDWARE			5.	CABLE CONNECTION HARDWARE		
6.	HEATING CABLE (length): 63' (19202mm)	1	CB-3045	6.	HEATING CABLE (length): 63' (19202mm)	1	CB-3045
7.	THERMOSTAT THERMOSTAT KNOB	1 1	TT-3498 KN-3473	7.	THERMOSTAT THERMOSTAT KNOB	1 1	TT-3498 KN-3473
8.	INDICATOR LIGHT (125V) INDICATOR LIGHT (230V)	1 1	LI-3027 LI-3025	8.	INDICATOR LIGHT (125V) INDICATOR LIGHT (230V)	1 1	LI-3027 LI-3025
9.	LIGHT SWITCH	1	SW-3616	9.	LIGHT SWITCH	1	SW-3616
10.	POWER "ON" SWITCH	1	SW-3041	10.	POWER "ON" SWITCH	1	SW-3041
11.	CORD & PLUG SET (125V) BUSHING (NOT SHOWN) CORD (230V) 6' (1829mm)	1 1 1	CD-3397 BU-3311 CD-3031	11.	CORD & PLUG SET (125V) BUSHING (NOT SHOWN) CORD (230V) 6' (1829mm)	1 1 1	CD-3397 BU-3311 CD-3031
12.	OUTER TOP	1	4168	12.	OUTER TOP	1	4168
13.	OUTER TOP MOUNTING SCREWS	4	SC-2459	13.	OUTER TOP MOUNTING SCREWS	4	SC-2459
14.	BULB (120V) BULB (230V)	6 6	LP-3542 LP-3543	14.	BULB (120V) BULB (230V)	6 6	LP-3542 LP-3543
15.	BULB RECEPTACLES (125V) O-RING (125V) BULB RECEPTACLES (230V)	6 6 6	RP-3952 SA-22377 RP-3955	15.	BULB RECEPTACLES (125V) O-RING (125V) BULB RECEPTACLES (230V)	6 6 6	RP-3952 SA-22377 RP-3955
16.	FRONT GUARD	1	GD-22123	16.	FRONT GUARD	1	GD-22360
17.	LIGHT GUARD	1	GD-22124	17.	LIGHT GUARD	1	GD-22124
18.	FRONT GLASS (CUSTOMER SIDE)	1	GL-2706	18.	FRONT GLASS (CUSTOMER SIDE)	1	GL-22362
19.	END GLASS	2	GL-22126	19.	END GLASS	2	GL-22126
20.	DOOR, LEFT-HAND DOOR HINGE, LEFT-HAND DOOR HINGE, LEFT-HAND	1 2 2	5894 HG-22169 HG-22167	20.	DOOR, LEFT-HAND DOOR HINGE, LEFT-HAND DOOR HINGE, LEFT HAND	1 2 2	5894 HG-22169 HG-22167
21.	DOOR, RIGHT-HAND DOOR HINGE, RIGHT-HAND DOOR HINGE, RIGHT-HAND	1 2 2	5895 HG-22170 HG-22168	21.	DOOR, RIGHT HAND DOOR HINGE, RIGHT-HAND DOOR HINGE, RIGHT-HAND	1 2 2	5895 HG-22170 HG-22168
22.	HANDLE	2	HD-2910	22.	HANDLE	2	HD-2910
23.	CONTROL PANEL OVERLAY CONTROL PANEL MOUNTING SCREWS	1 6	PE-2978 SC-2459	23.	CONTROL PANEL OVERLAY CONTROL PANEL MOUNTING SCREWS	1 6	PE-2878 SC-2459
24.	PAN DIVIDER BARS (NOT SHOWN) —FULL, HALF & THIRD SIZE (LONG) —SHEET PAN (LONG) —SHEET PAN (SHORT) —FULL, HALF & THIRD SIZE (SHORT)	1 1 1 4	1455 1472 1473 11318	24.	PAN GRID (NOT SHOWN)	1	PN-2115
	OPTIONS (NOT SHOWN)				OPTIONS (NOT SHOWN)		
25.	MIRRORED GLASS DOOR ASSEMBLY, LEFT HAND MIRRORED GLASS DOOR ASSEMBLY, RIGHT HAND	1 1	14469 14470	25.	MIRRORED GLASS DOOR ASSEMBLY, LEFT-HAND MIRRORED GLASS DOOR ASSEMBLY, RIGHT HAND	1 1	14469 14470

*Disconnect Unit
From Power Source
Before Cleaning and
Servicing*



SERVICE VIEWS • See following pages.

MCD-30
SERVICE VIEW

10-23-90

3/32"=1"

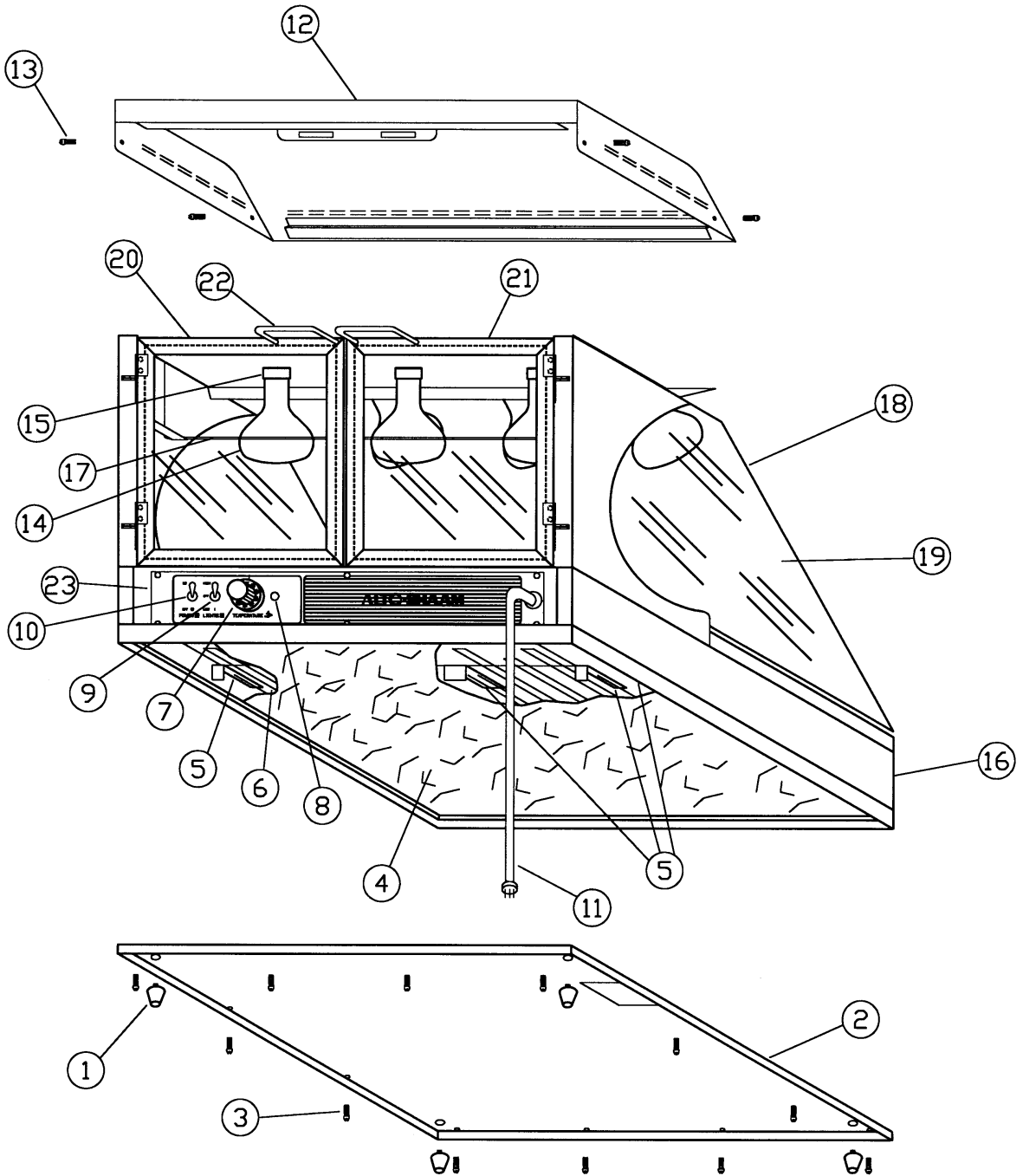

MCD-30/P

SERVICE VIEW

3/32"=1"

8-26-92

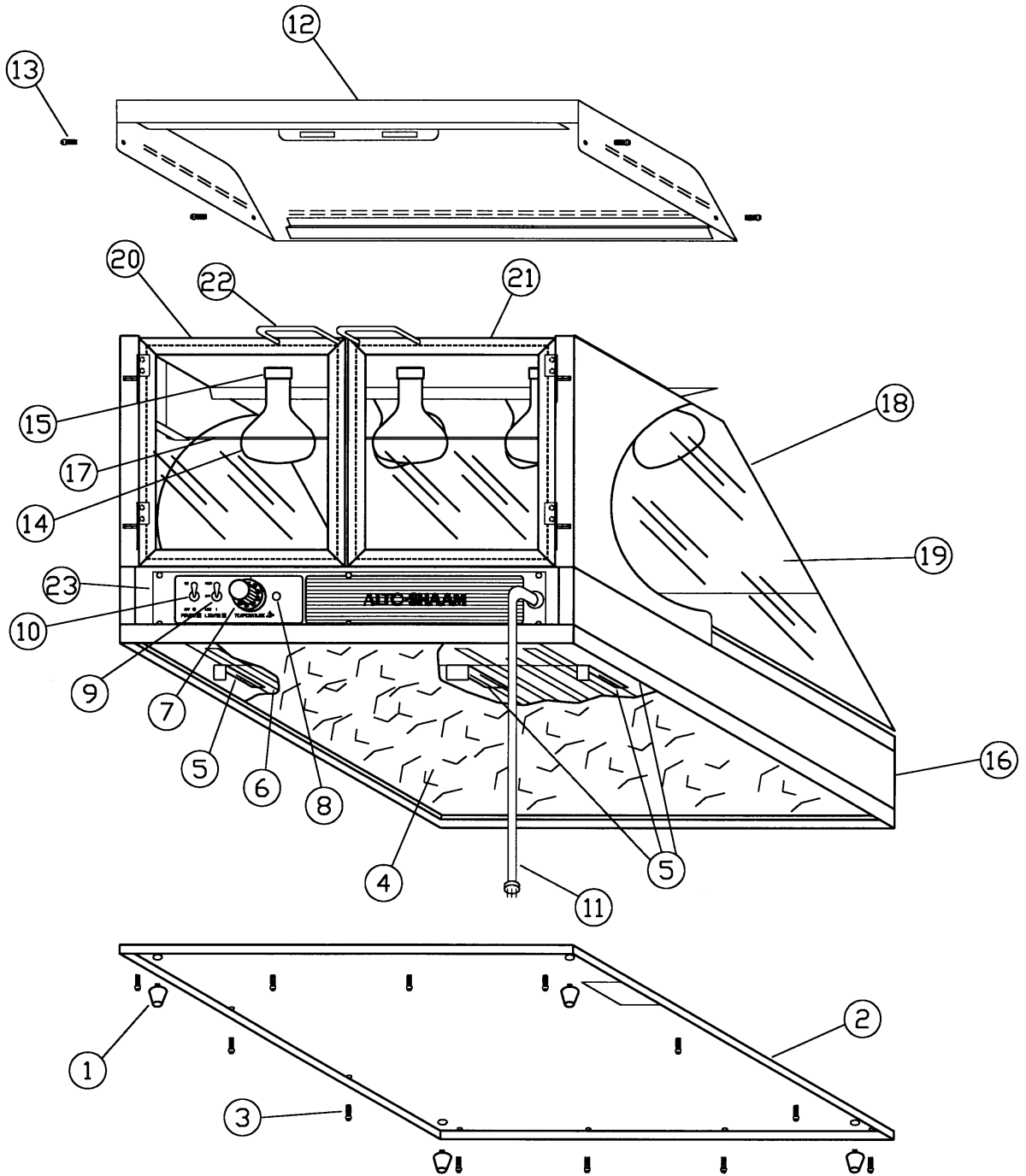

SERVICE VIEW PARTS LIST

SC-30

5-3-00

Part Description	Qty.	Alto-Shaam Part No.
1. LEGS, 1" (25mm)	4	LG-2043
2. BOTTOM ASSEMBLY	1	4502
3. BOTTOM ASSEMBLY MOUNTING SCREWS	14	SC-2459
4. INSULATION: -SIZE: 24-1/2" X 30" (622mm x 762mm)	1	IN-2381
5. ELEMENT CLAMP	1	1761
6. ELEMENT CLAMP MOUNTING SCREWS	2	SC-2459
7. BUTT CONNECTOR	2	CR-3067
8. HEATING CABLE ELEMENT	1	CB-3524
9. THERMOSTAT	1	TT-3978
THERMOSTAT KNOB	1	KN-3473
10. HEAT INDICATOR LIGHT, 125V	1	LI-3027
HEAT INDICATOR LIGHT, 220V	1	LI-3025
11. POWER SWITCH	1	SW-3041
12. LIGHT SWITCH	1	SW-3616
13. CORD & PLUG SET, 125V	1	CD-3232
CORD, 220V, 6' (1829mm)	1	CD-3508
14. TOP	1	1064
15. TOP MOUNTING SCREWS	4	SC-2459
16. BULB, 120V	4	LP-3542
BULB, 220V	4	LP-3543
17. BULB SOCKET, 125V	4	RP-3952
BULB SOCKET, 220V	4	RP-3955
18. SNEEZE GUARD ASSEMBLY	1	4507
WINDOW LATCH	6	LT-2195
WINDOW LATCH MOUNTING SCREWS	6	SC-2472
19. FRONT GLASS ASSEMBLY	1	4506
WINDOW LATCH	2	LT-2195
WINDOW LATCH MOUNTING SCREWS	2	SC-2472
20. ADJUSTABLE RACK	1	SR-2673
21. CHUTE DIVIDERS	4	1979
CHUTE DIVIDER MOUNTING SCREWS	4	SC-2459
22. CONTROL PANEL OVERLAY	1	PE-2855

SERVICE VIEW • See following page.

SC-30 Options & Accessories

Chute Dividers	SR-2673
<i>For System Bases:</i>	
Legs, 6" (152mm)	5205
Shelves, Chrome Plated Wire	
- 750-GDU or CTUS reach-in angled	SH-2851
- 750-GDU reach-in, flat	SH-2114
- 750-GDU/PT pass-thru, flat	SH-2114
Wire Pan Grid	PN-2115

SAFETY ALERT



CAUTION

This unit's performance has been optimized using the factory provided bulbs. These bulbs should be replaced with an exact replacement or with a factory recommended replacement. These bulbs have been treated to resist breakage and must be replaced with similarly treated bulbs in order to maintain compliance with NSF standards.



CAUTION

Cable Heating Service Kit	4878
<i>includes:</i>	
CB-3045	Cable Heating Element 72 feet
CR-3226	Ring Connector 4
IN-3488	Insulation Corner 1 foot
BU-3105	Shoulder Bushing 4
BU-3106	Cup Bushing 4
SL-3063	Insulating Sleeve 4
TA-3540	High Temperature Tape 1 foot
ST-2439	Stud, 10/32 4
NU-2215	Hex Nut 8
BX-2588	Cable Box 1
BX-2591	Cable Box 1

*Disconnect Unit
From Power Source
Before Cleaning and
Servicing*



CAUTION

MCD-30 Options & Accessories

Custom Panels	.FACTORY QUOTE
Doors, reflective tempered glass	.GL-23487
Glass, End, mirrored, tempered, RH	.GL-24121
Glass, End, mirrored, tempered, LH	.LGL-24122
Pan Separator Bars	
- full/half/third size (long)	.1455
- full/half/third size (short)	.1473
- sheet pan separators	.1472/1473
Menu Board	.MB-23091
Mirrored Glass Doors:	
- Left-hand assembly	.14469
- Right-hand assembly	.14470
Self-serve pan grid	.PN-2115

SC-30
SERVICE VIEW

12-11-87
1/4=1

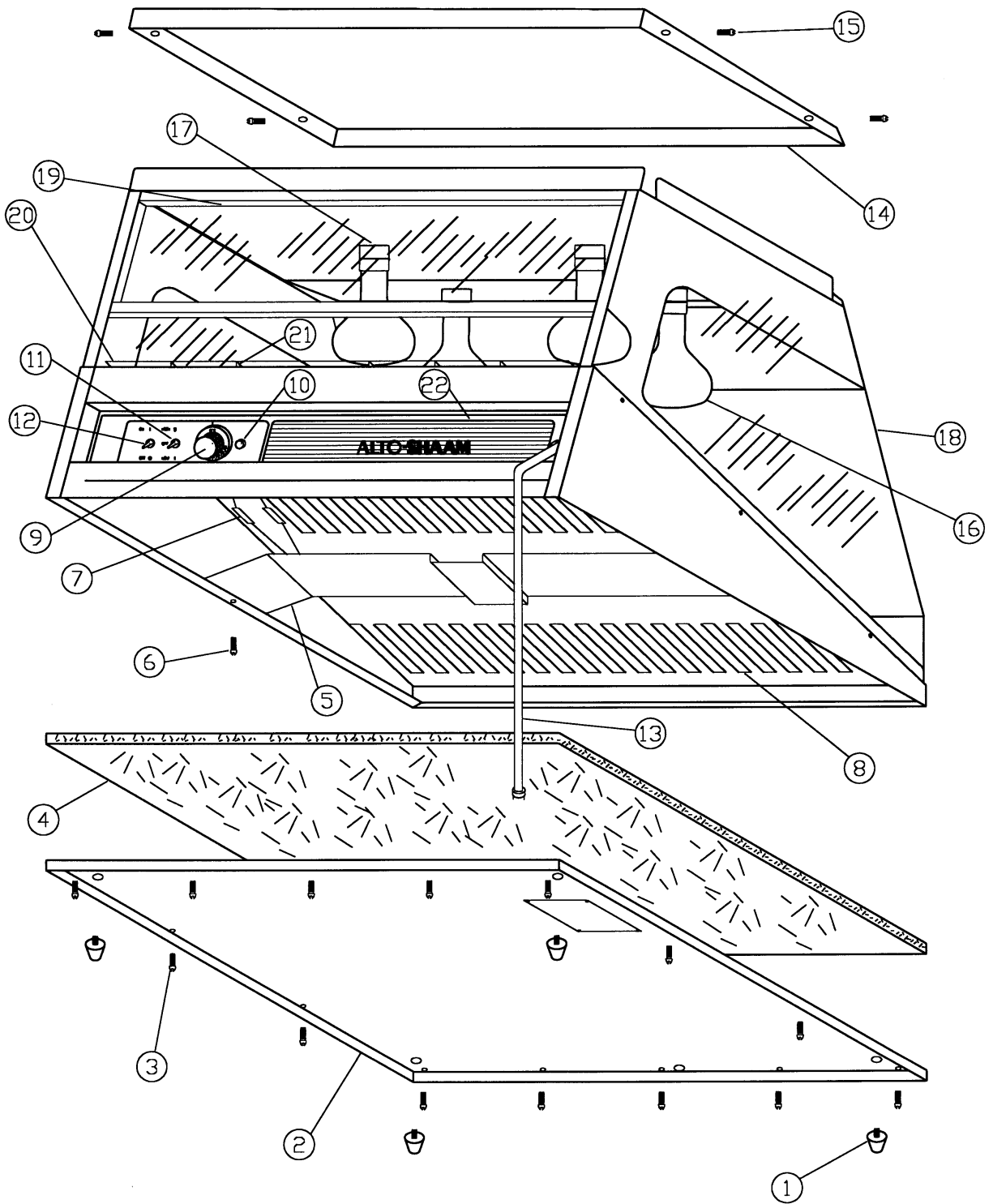

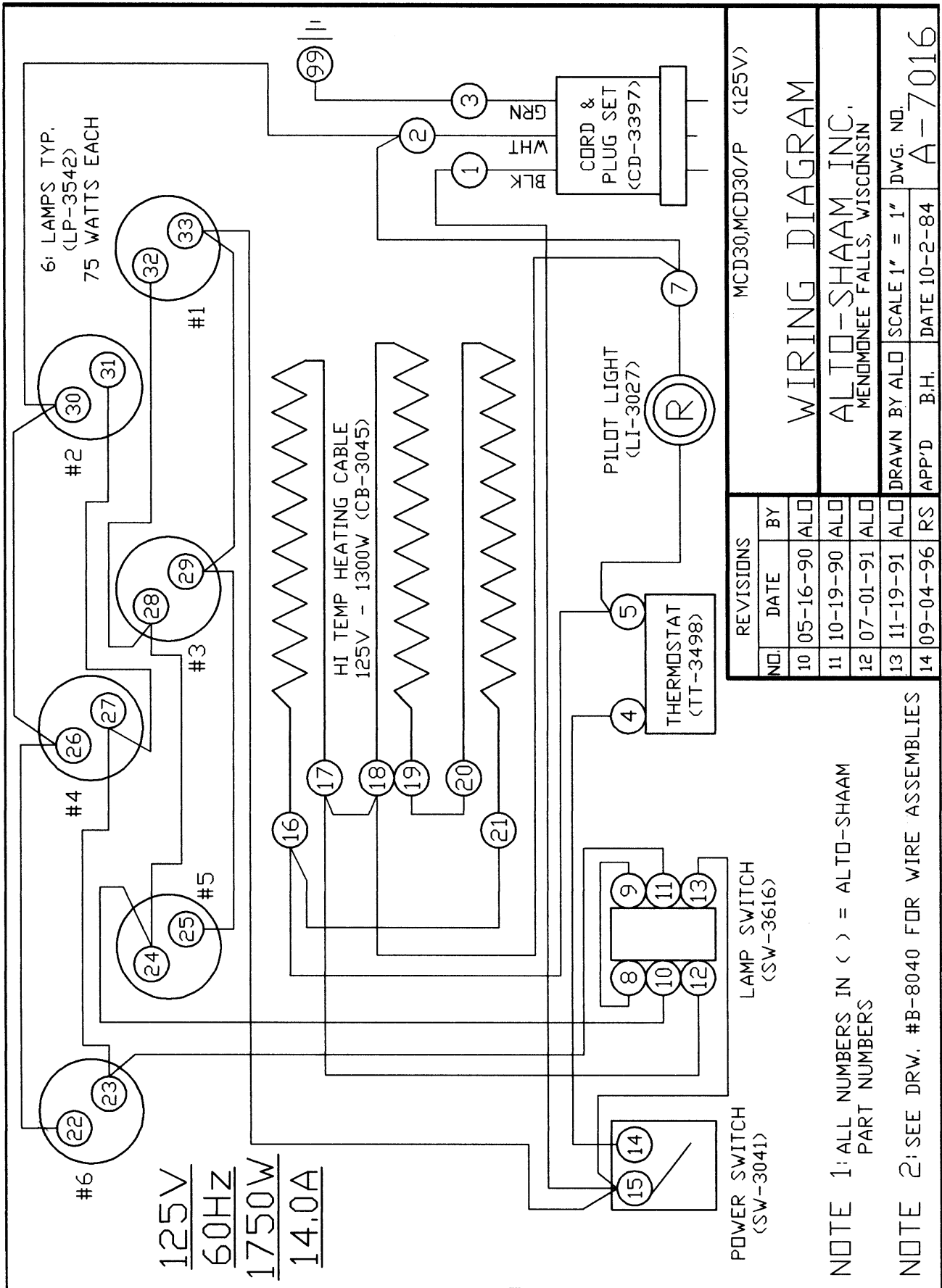

MCD30,MCD30/P (125V)

WIRING DIAGRAM

ALTO-SHAAM INC.
MEMONONEE FALLS, WISCONSIN

DRAWN BY ALO SCALE 1" = 1" DWG. NO. A-7016
APP'D B.H. DATE 10-2-84

REVISIONS	
NO.	DATE
10	05-16-90
11	10-19-90
12	07-01-91
13	11-19-91
14	09-04-96

NOTE 1: ALL NUMBERS IN () = ALTO-SHAAM PART NUMBERS

NOTE 2: SEE DRW. #B-8040 FOR WIRE ASSEMBLIES

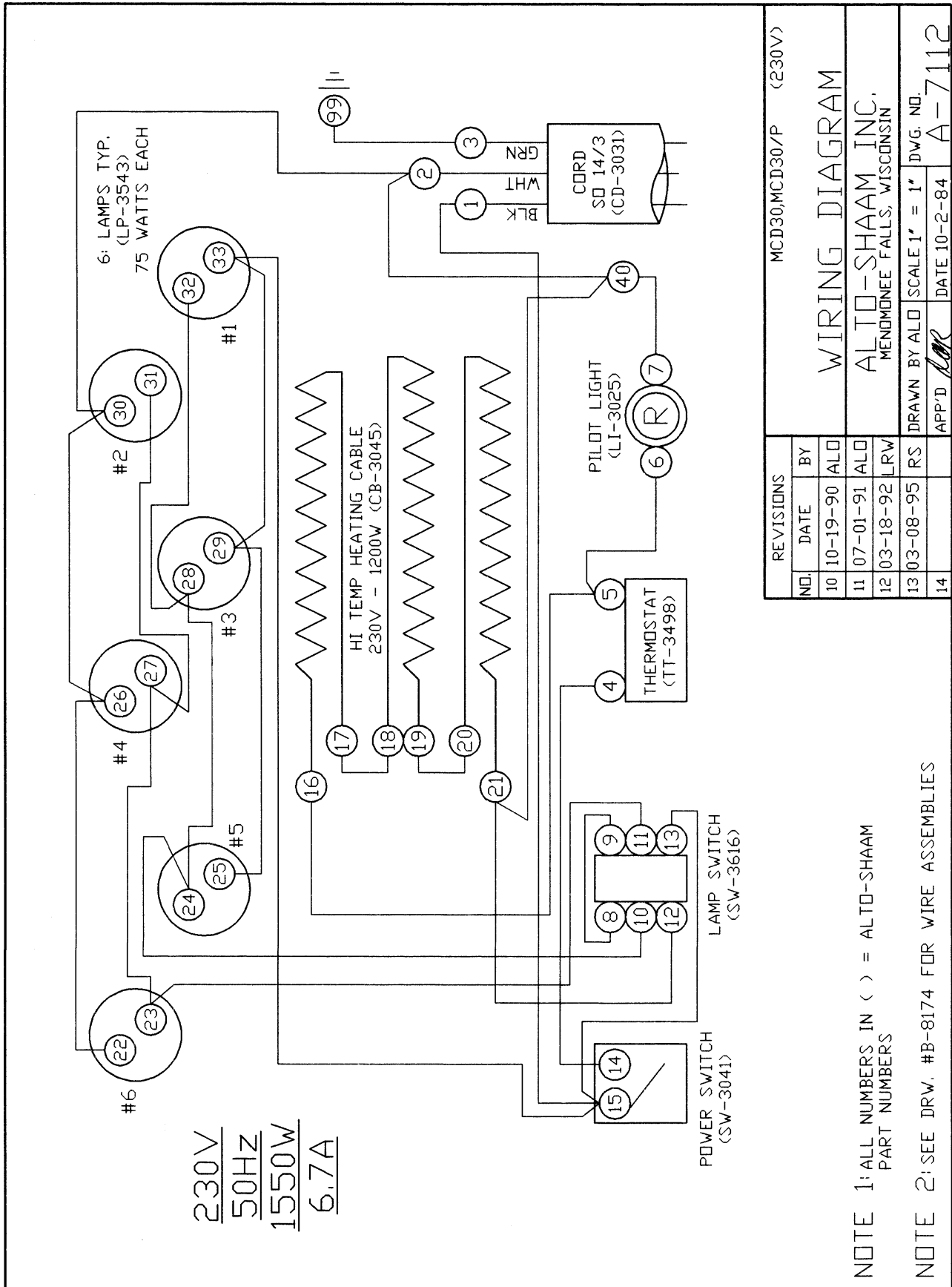

REVISIONS		MCD30,MCD30/P (230V)	
NO.	DATE	BY	
10	10-19-90	ALD	
11	07-01-91	ALD	
12	03-18-92	LRW	
13	03-08-95	RS	
14			

WIRING DIAGRAM

ALTO-SHAAM INC.
MEMONEE FALLS, WISCONSIN

DRAWN BY ALD SCALE 1" = 1" DWG. NO. A-7112

APP'D *LR* DATE 10-2-84

NOTE 1: ALL NUMBERS IN () = ALTO-SHAAM PART NUMBERS

NOTE 2: SEE DRW. #B-8174 FOR WIRE ASSEMBLIES

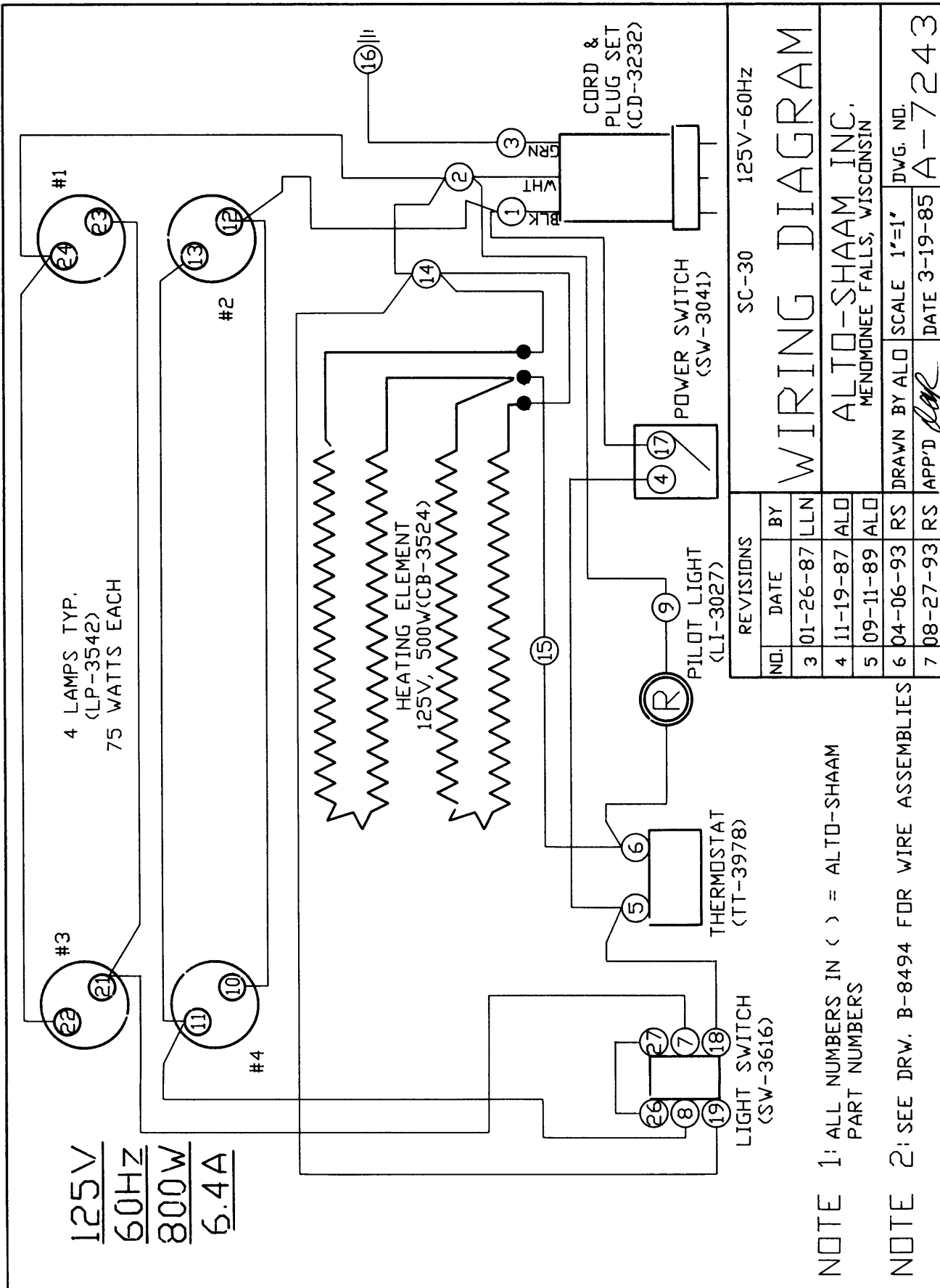

TRANSPORTATION DAMAGE and CLAIMS



All Alto-Shaam equipment is sold F.O.B. shipping point, and when accepted by the carrier, such shipments become the property of the consignee.

Should damage occur in shipment, it is a matter between the carrier and the consignee. In such cases, the carrier is assumed to be responsible for the safe delivery of the merchandise, unless negligence can be established on the part of the shipper.

1. Make an immediate inspection while the equipment is still in the truck or immediately after it is moved to the receiving area. Do not wait until after the material is moved to a storage area.
2. Do not sign a delivery receipt or a freight bill until you have made a proper count and inspection of all merchandise received.
3. Note all damage to packages directly on the carrier's delivery receipt.
4. Make certain the driver signs this receipt. If he refuses to sign, make a notation of this refusal on the receipt.
5. If the driver refuses to allow inspection, write the following on the delivery receipt:
Driver refuses to allow inspection of containers for visible damage.
6. Telephone the carrier's office immediately upon finding damage, and request an inspection. Mail a written confirmation of the time, date, and the person called.
7. Save any packages and packing material for further inspection by the carrier.
8. Promptly file a written claim with the carrier and attach *copies* of all supporting paperwork.

We will continue our policy of assisting our customers in collecting claims which have been properly filed and actively pursued. We cannot, however, file any damage claims for you, assume the responsibility of any claims, or accept deductions in payment for such claims.

ALTO-SHAAM® LIMITED WARRANTY

Alto-Shaam, Inc. warrants to the original purchaser that any original part that is found to be defective in material or workmanship will, at our option, subject to provisions hereinafter stated, be replaced with a new or rebuilt part.

The labor warranty remains in effect one (1) year from installation or fifteen (15) months from the shipping date, whichever occurs first.

The parts warranty remains in effect one (1) year from installation or fifteen (15) months from the shipping date, whichever occurs first.

Exceptions to the one year part warranty period are as listed:

- A. Halo Heat cook/hold ovens include a five (5) year parts warranty on the heating element. Labor will be covered under the terms of the standard warranty period of one (1) year or fifteen (15) months.
- B. Alto-Shaam Quickchillers include a five (5) year parts warranty on the refrigeration compressor. Labor will be covered under the terms of the standard warranty period of one (1) year or fifteen (15) months.

This warranty does not apply to:

1. Calibration
2. Replacement of light bulbs and/or the replacement of display case glass due to damage of any kind.
3. Equipment damage caused by accident, shipping, improper installation or alteration.
4. Equipment used under conditions of abuse, misuse, carelessness or abnormal conditions.
5. Any losses or damage resulting from malfunction, including loss of product or consequential or incidental damages of any kind.
6. Equipment modified in any manner from original model, substitution of parts other than factory authorized parts, removal of any parts including legs, or addition of any parts.

This warranty is exclusive and is in lieu of all other warranties, expressed or implied, including the implied warranties of merchantability and fitness for purpose. In no event shall the Company be liable for loss of use, loss of revenue, or loss of product or profit, or for indirect or consequential damages. This warranty is in lieu of all other warranties expressed or implied and Alto-Shaam, Inc. neither assumes or authorizes any persons to assume for it any other obligation or liability in connection with Alto-Shaam equipment.

ALTO-SHAAM, INC.

Warranty effective January 1, 2000

Record the model and serial numbers of the unit for easy reference.

Always refer to both model and serial numbers in your correspondence regarding the unit.

Model: _____
Serial Number: _____
Purchased From: _____
Date Installed: _____ Voltage: _____

HALO HEAT COOK/HOLD/SERVE SYSTEMS BY ALTO-SHAAM®

W164 N9221 Water Street • P.O. Box 450 • Menomonee Falls, Wisconsin 53052-0450 • U.S.A.

PHONE: 262.251.3800

FAX: 262.251.7067 • 800.329.8744 U.S.A./CANADA

WEBSITE:

800.558.8744 U.S.A./CANADA

262.251.1907 INTERNATIONAL

www.alto-shaam.com

PRINTED IN U.S.A.