

Converge[®]

Simple Control

CMC-H2H

CMC-H3H



Structured Air Technology™

MN-47238-EN

REV.04
04/24

EN

For the most current manual, visit alto-shaam.com
Die neueste Fassung des Handbuchs finden Sie auf alto-shaam.com
Pour la dernière version du manuel, visiter alto-shaam.com
Para obtener el manual más actual, visite alto-shaam.com
Ga voor de meest recente handleiding naar alto-shaam.com



Manufacturer's Information

Copyright

© Copyright 4/24 by Alto-Shaam, Inc.

All rights reserved.

This manual or any portion thereof may not be reproduced or used in any manner whatsoever without the express written permission of Alto-Shaam, Inc.

Trademarks

All trademarks referenced in this documentation are the property of their respective owners.

Manufacturer

Alto-Shaam, Inc.

P.O. Box 450

W164 N9221 Water Street

Menomonee Falls, WI 53052

Original instructions

The content in this manual is written in American English.

Enjoy your Alto-Shaam Converge Oven!

Structured Air Technology™

The Alto-Shaam Converge Oven features Structured Air Technology, giving you two or three ovens in one. It combines the flexibility of a multi-cook oven and the versatility of combi cooking in each oven chamber. Two or three independent ovens in one give you the freedom to steam, air fry, bake, grill, and more at the same time without flavor transfer—all in a ventless, self-cleaning design. It provides the ability to control temperature, fan speed, humidity level, and cook time in each individual oven chamber.

Extend Your Manufacturer's Warranty

Register

Register your Alto-Shaam appliance online. Registering your appliance ensures prompt service in the event of a warranty claim.

Your personal information will not be shared with any other company.

alto-shaam.com/warranty

Alto-Shaam 24/7 Emergency Repair Service

Call

Call 800-558-8744 to reach our 24-hour emergency service call center for immediate access to local authorized service agencies outside standard business hours. The emergency service access is provided exclusively for Alto-Shaam equipment and is available throughout the United States through Alto-Shaam's toll free number.

Availability

Emergency service access is available seven days a week, including holidays.

This page is intentionally left blank.

Manufacturer’s Information 2

Foreword 3

 Enjoy your Alto-Shaam Converge Oven! 3

 Extend Your Manufacturer’s Warranty 3

 Alto-Shaam 24/7 Emergency Repair Service 3

Table of Contents 5

Safety 7

 The Meaning of Signal Words 7

 Appliance Description and Intended Use. 8

 Safety Precautions. 9

Labels 13

 Label Locations 13

Installation 21

 Dimension Drawings 21

 How to Unpack the Oven 23

 How to Install the Water Supply and Drain. 24

 How to Install the Oven (60 Hz Cord and Plug Models). 30

 How to Install the Oven (50 Hz Models Without Cord or Plug). 33

 How to Install the Oven on a Stand 38

 How to Install the Jet Plates 44

Operation 47

 How to Turn On and Turn Off the Oven 47

 How to Preheat the Oven. 48

 How to Cook with Programmed Recipes 50

 How to Cook in Professional Mode 52

 How to Use the Dual Timers 55

 How to Lock and Unlock the Screen. 58

 How to Cool Down the Oven. 59

 How to Create a Recipe. 60

 How to Modify or Delete a Recipe. 64

 How to Backup or Restore Settings with a USB Drive. 66

 How to Load Recipes from a USB Drive. 68

 How to Save Recipes to a USB Drive 70

 How to Update Software with a USB Drive 72

 How to Change the Home Screen 74

 How to Change the Temperature Scale. 76

 How to Enable the Handle Light. 78

 How to Enable/Disable Automatic Preheat. 79

 How to Lock Recipe Editing or the Settings Screen 80

TABLE OF CONTENTS

How to View Oven Information	82
How to Download HACCP Data	83
How to Calibrate the Temperature Probe	85
Maintenance	87
Maintenance Schedule	87
How to Clean the Oven.	89
How to Descale the Catalyst	93
How to View the Cleaning Log	96
How to Set the Cleaning Time.	97
Troubleshooting	99
Error Codes	99
What to do if the Fan Indicator Light Illuminates.	102
What to do if the High Limit Screen Displays	103
Warranty	105
Warranty.	105
Declaration of Conformity	107

The Meaning of Signal Words

This manual contains signal words where needed. These signal words must be obeyed to reduce the risk of death, personal injury, or equipment damage. The meaning of these signal words is explained below.

**DANGER**

Danger indicates a hazardous situation which, if not avoided, will result in serious injury or death.

**WARNING**

Warning indicates a hazardous situation which, if not avoided, could result in serious injury or death.

**CAUTION**

Caution indicates a hazardous situation which, if not avoided, could result in minor or moderate injury.

NOTICE

Notice indicates a situation which, if not avoided, could result in property damage.



NOTE: Note indicates additional information that is important to a concept or procedure.

Appliance Description and Intended Use

Structured Air Technology®

Alto-Shaam Structured Air Technology system allows for multiple, unique cooking chambers within the same oven. Air is delivered by a blower located in the rear of each cooking chamber. Air travels vertically through the jet plates into each chamber. The food product is blown with hot air from above and below. Structured Air plates at the top and bottom of the oven complete the upper and lower cooking chambers. Each cooking chamber is independent from the other and includes its own blower and heat source. The operator can select the optimal cooking temperature, air velocity, humidity level, and cook time for each chamber either manually or through programmed recipes.

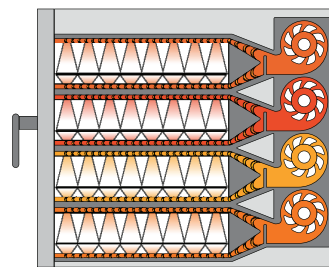

5:30



60%



400°

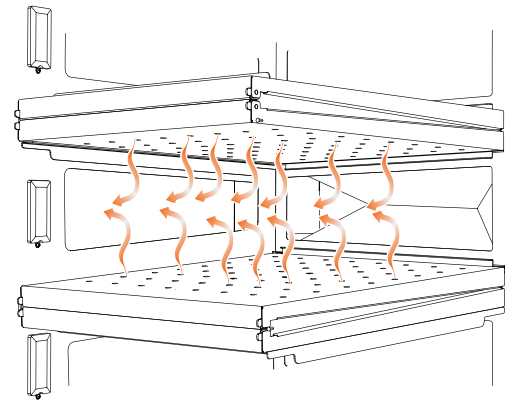

VMC-TS-000271

Nomenclature

CMC-H2H means Combi Multi-Cook, half-size, two-chamber, and hotel pans.
CMC-H3H means Combi Multi-Cook, half-size, three-chamber, and hotel pans.

Configurations

Converge is available in two configurations: two- and three-chamber.

Intended use

Converge ovens are intended to cook and steam food only. Any other use is prohibited. This appliance is intended to be used for commercial applications, for example in kitchens of restaurants, canteens, hospitals and in commercial enterprises such as bakeries, butcheries, etc., but not for continuous mass production of food.

Residual risks

This oven is manufactured using ISO-certified processes. The oven is designed with maximum safety in mind; however, there are residual risks to operators of this oven. Residual risks include exposure to heat and exposure to hot food products.

Possible misuse

Misuse of this oven includes loading the oven with anything other than a food product. Misuse also includes heating or cooking any food product that contains alcohol or other flammable substance.

Safety Precautions

Before you begin

Read and understand all instructions in this manual.

Electrical precautions

Obey these electrical precautions when using the appliance:

- Connect the appliance to a properly grounded outlet. Do not use the appliance if it is not properly grounded. Consult an electrician if there is any doubt that the outlet used is properly grounded.
 - Keep the cord away from hot surfaces.
 - Do not attempt to service the appliance or its cord and plug.
 - Do not operate the appliance if it has a damaged cord or plug.
 - Do not immerse the cord or plug in water.
 - Do not let the cord hang over the edge of a table or counter.
 - Do not use an extension cord.
-

Usage precautions

Obey these usage precautions when using the appliance:

- Only use this appliance for its intended use of heating or cooking.
 - Always keep liquids, or foods that can become liquid when heated, level and at or below eye level where they can be seen.
 - Use utensils and protective clothing such as dry oven mitts when loading and unloading the appliance.
 - Use caution when using the appliance. Floors adjacent to the appliance may become slippery.
 - Do not cover or block any of the openings of this appliance.
 - Do not cover racks or any other part of this appliance with metal foil.
 - Do not keep anything underneath the oven. Cooling air circulates through the bottom for the electronics.
 - Do not use this appliance near water such as a sink, in a wet location, near a swimming pool, or similar locations.
 - Do not unplug or disconnect the appliance immediately after cooking. The cooling fans must stay on to protect electrical components.
-

Maintenance precautions

Obey these maintenance precautions when maintaining the appliance:

- Obey precautions in the manual, on tags, and on labels attached to or shipped with the appliance.
- Do not store the appliance outdoors.
- Do not clean the appliance with metal scouring pads.
- Do not use corrosive chemicals when cleaning the appliance.
- Do not use a hose, water jet, or steam cleaner to clean the exterior of the appliance.
- Do not use the appliance cavity for storage.
- Do not leave flammable materials, cooking utensils, or food inside the appliance when it is not in use.
- Do not remove the top cover or side panels. There are no user-serviceable components inside.

Operator training

All personnel using the appliance must have proper operator training. Before using the appliance:

- Read and understand the operating instructions contained in all the documentation delivered with the appliance.
- Know the location and proper use of all controls.
- Keep this manual and all supplied instructions, diagrams, schematics, parts lists, notices, and labels with the appliance if the appliance is sold or moved to another location.
- Contact Alto-Shaam for additional training if needed.

Operator qualifications

Only trained personnel with the following operator qualifications are permitted to use the appliance:

- Have received proper instruction on how to use the appliance.
- Have demonstrated their ability with commercial kitchens and commercial appliances.

The appliance must not be used by:

- Persons (including children) with reduced physical, sensory or mental capabilities, or lack of experience and knowledge, unless they have been given supervision concerning use of the appliance by person responsible for their safety.
- People impaired by drugs or alcohol.

- Children should be supervised to ensure that they do not play with the appliance.
- Children shall neither clean nor maintain the appliance.

Condition of appliance

Only use the appliance when:

- All controls operate correctly.
- The appliance is installed correctly.
- The appliance is clean.
- The appliance labels are legible.

Servicing the appliance

- Only trained personnel are permitted to service or repair the appliance. Repairs that are not performed by an authorized service partner or trained technician will void the warranty and relieve Alto-Shaam of all liability. Original manufacturer's replacement parts may be substituted; however, these parts must be of equal quality and specifications as those provided by Alto-Shaam.
- To prevent serious injury, death or property damage, have the appliance inspected and serviced at least every twelve (12) months by an authorized service partner or trained technician.
- Contact Alto-Shaam for the authorized service partner in your area.

Sound power

The A-weighted sound pressure level is below 70 dB(A).

Personal Protective Equipment (PPE)

Wear the following Personal Protective Equipment (PPE) while cleaning the appliance:

- Protective gloves
- Protective clothing
- Eye protection
- Face protection

This page is intentionally left blank.



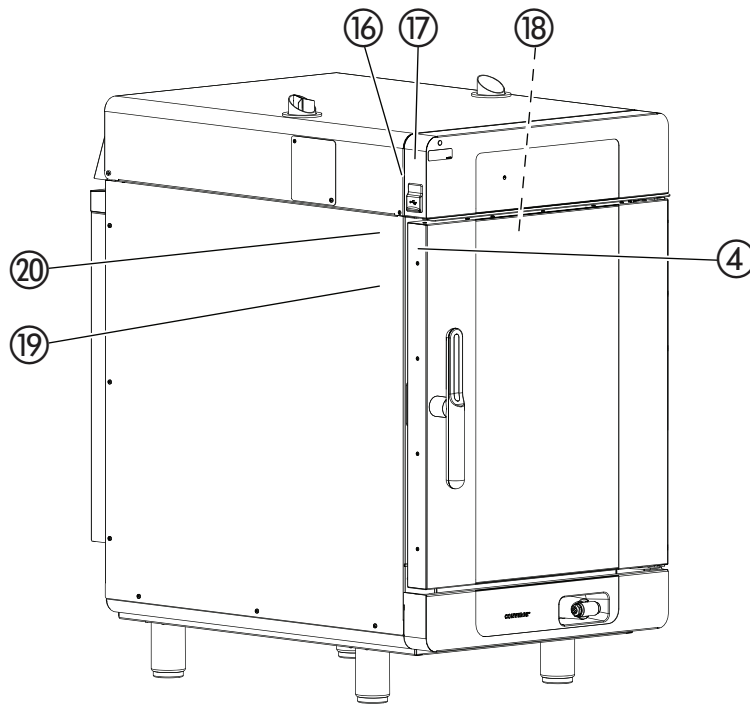
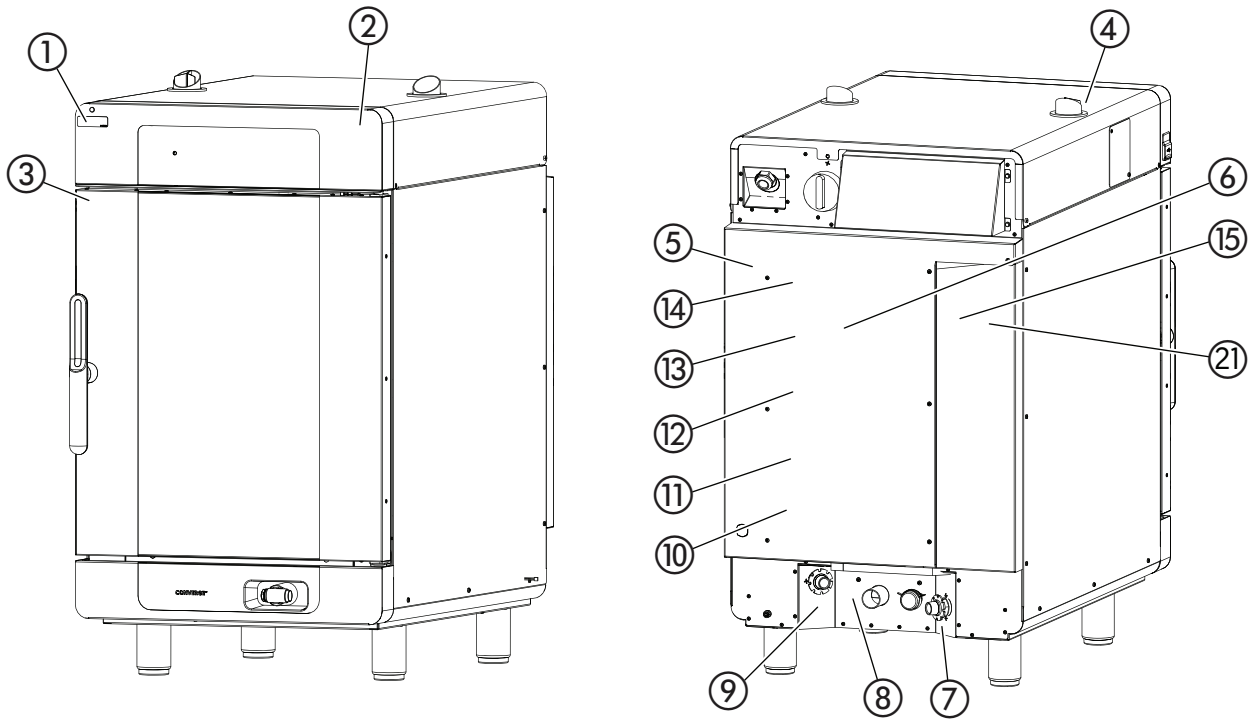

Label Locations



CT-PHD-013963

LABELS

LABELS

<p>1</p>	<div data-bbox="259 216 639 338" style="border: 1px solid black; border-radius: 10px; padding: 5px;"> <p>Check fans Compruebe los ventiladores Vérifiez les ventilateurs</p> <p style="text-align: right; font-size: small;">LA-39033</p> </div> <div data-bbox="259 373 639 495" style="border: 1px solid black; border-radius: 10px; padding: 5px; margin-top: 10px;">  <p style="text-align: right; font-size: small;">LA-39280</p> </div>	<p>Check fans</p>
<p>2</p>		<p>Made in U.S.A.</p>
<p>3</p>		<p>WARNING Steam. Open door carefully.</p>
<p>4</p>		<p>WARNING Hot surface</p>
<p>5</p>	<div data-bbox="259 1098 643 1318" style="border: 1px solid black; border-radius: 10px; padding: 10px;"> <p style="text-align: center;">ALTO-SHAAM.</p> <p>Every Alto-Shaam product is precision calibrated prior to release from the factory to ensure accurate temperature control.</p> <p style="text-align: center;">CALIBRATION TECHNICIAN _____</p> <p style="font-size: x-small;">LA-26378</p> </div>	<p>Every Alto-Shaam product is precision calibrated prior to release from the factory to ensure accurate temperature control.</p>

6

**WARNING
ADVERTENCIA
AVERTISSEMENT**

Failure to follow cleaning instructions can cause injury or equipment damage. Clean oven only with Alto-Shaam cleaning tablets. Avoid contact with skin or eyes. Wear PPE. Read and understand the safety data sheet and the operator's manual before cleaning.

Si no se siguen las instrucciones de limpieza, puede sufrir lesiones o daños en el equipo. Limpie el horno solo con las pastillas de limpieza de Alto-Shaam. Evite el contacto con la piel o los ojos. Use equipo de protección personal (Personal Protective Equipment, PPE). Lea completamente la hoja de datos de seguridad y el manual del operador antes de realizar la limpieza.

Pour écarter les risques de blessures ou de dégâts matériels, veillez à respecter les instructions de nettoyage. Nettoyer le four uniquement avec les pastilles nettoyantes Alto-Shaam. Éviter le contact avec la peau et les yeux. Porter un EPI. Lire et comprendre la fiche de données de sécurité et le manuel de l'utilisateur avant de nettoyer.

LA-48004

LA-39149

WARNING

Failure to follow cleaning instructions can cause injury or equipment damage. Clean oven only with Alto-Shaam concentrated cleaning tablets. Cleaner is caustic. Avoid contact with skin or eyes. Wear PPE. Read and understand the safety data sheet and the operator's manual before cleaning.

7

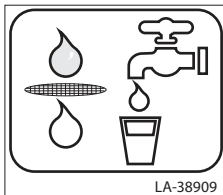

Treated, drinkable water connection point.

8



Drain water connection point.

9



Untreated, drinkable water connection point.

10

⚠ WARNING/ADVERTENCIA/AVERTISSEMENT

Electric Shock Hazard
Appliances with permanent electrical connection that are mounted on casters must be secured to building structure. Read installation instructions.

Peligro de descarga eléctrica
Los equipos con una conexión eléctrica permanente que estén montados sobre ruedas deben estar fijos a la estructura del edificio. Lea las instrucciones de instalación.

Risque d'électrocution
Les appareils à branchement électrique fixe qui sont montés sur roulettes doivent être attachés à la structure du bâtiment. Lire les instructions d'installation.

LA-38912

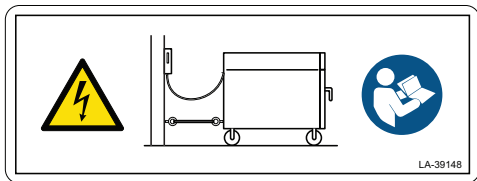

WARNING

Electric shock hazard

Appliances with permanent electrical connections that are mounted on casters must be secured to building structure. Read installation instructions.

11

⚠ WARNING/ADVERTENCIA/AVERTISSEMENT

Fire Hazard
This appliance is only for use with factory-supplied legs, casters, or base.

Peligro de incendio
Este aparato solo se puede usar con patas, ruedas o base proporcionadas por la fábrica.

Risque d'incendie
Ce appareil est destiné à être utilisé uniquement avec les pieds, les roulettes ou le socle fournis par le fabricant.

LA-39335

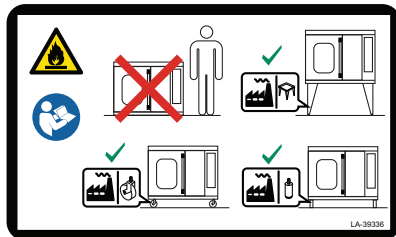

WARNING

Fire hazard

This oven is only for use with factory-supplied legs, casters, or base.

12

⚠ WARNING/ADVERTENCIA/AVERTISSEMENT

Fire Hazard
For use only on noncombustible surfaces. Maintain the correct clearances to combustibles.

Peligro de incendio
Solo para uso en superficies no combustibles. Mantenga las distancias correctas de elementos combustibles.

Risque d'incendie
Utilisation sur des surfaces non combustibles seulement. Maintenez des dégagements corrects par rapport aux matières combustibles.

	Combustibles	Non-combustibles
Top/lope/haut	2" (51mm)	2" (51mm)
Left/izquierda/gauche	2" (51mm)	2" (51mm)
Right/derecho/droite	2" (51mm)	2" (51mm)
Rear/posterior/arrière	2" (51mm)	2" (51mm)

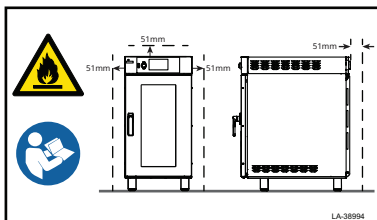

LA-39090



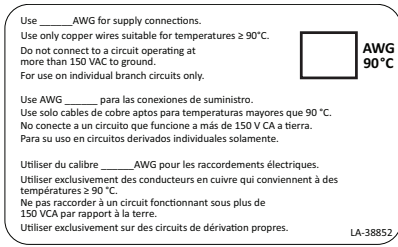
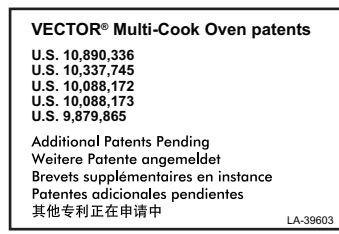

WARNING

Fire hazard

For use only on noncombustible surfaces. Maintain the correct clearances to combustibles.

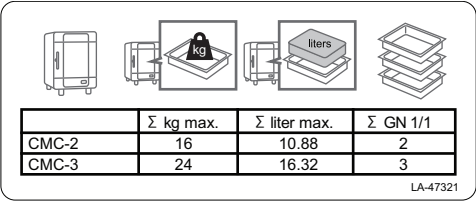
<p>13</p>		<p>WARNING</p> <p>Electric shock hazard</p> <p>To reduce the risk of electric shock, do not remove or open cover. No user-serviceable parts inside. Refer servicing to qualified personnel.</p> <p>Qualified personnel: Disconnect power before servicing.</p>
<p>14</p>		<p>Note: This label is only used on UL-certified appliances that have 120V to ground wiring.</p> <p>Use _____ AWG for supply connections.</p> <p>Use only copper wires suitable for temperature less than or equal to 90°C.</p> <p>Do not connect to a circuit operating at more than 150 VAC to ground.</p> <p>For use on individual branch circuits only.</p>
<p>15</p>		<p>Vector Multi-Cook Oven Patents</p>
<p>16</p>		<p>Certificate of Approval number, Fire Department - City of New York.</p>
<p>17</p>		<p>Security seal</p>

<p>18</p>		<p>WARNING</p> <p>Burn hazard</p> <p>Always load liquids, or foods that can become liquid when heated, at an eye level where they can be seen.</p>												
<p>19</p>	 <table border="1" data-bbox="280 716 716 783"> <thead> <tr> <th></th> <th>Σ kg max.</th> <th>Σ liter max.</th> <th>Σ GN 1/1</th> </tr> </thead> <tbody> <tr> <td>CMC-2</td> <td>16</td> <td>10.88</td> <td>2</td> </tr> <tr> <td>CMC-3</td> <td>24</td> <td>16.32</td> <td>3</td> </tr> </tbody> </table>		Σ kg max.	Σ liter max.	Σ GN 1/1	CMC-2	16	10.88	2	CMC-3	24	16.32	3	<p>Retherm maximum capacity</p>
	Σ kg max.	Σ liter max.	Σ GN 1/1											
CMC-2	16	10.88	2											
CMC-3	24	16.32	3											
<p>20</p>	<p>For use on individual branch circuit only.</p> <p>Utiliser exclusivement sur un propre circuit de dérivation séparé.</p> <p>Nur zum Anschluss an einen Einzelstromkreis geeignet.</p> <p>Para su uso en circuitos derivados individuales solamente.</p> <p>禁止和其他任何电器设备共用供电回路。必须独立分配一路给该设备</p> <p>LA-3088</p>	<p>For use on individual branch circuit only.</p>												
<p>21</p>		<p>Alto-Shaam technical service QR code</p>												

<p>—</p>		<p>Press and release the high limit temperature reset button(s).</p>
<p>—</p>	<p>LA-36443-E</p>	<p>Equipotential terminal</p>
<p>—</p>		<p>Consult instructions for operation and use.</p>

This page is intentionally left blank.

Dimension Drawings

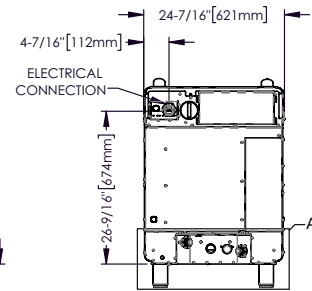
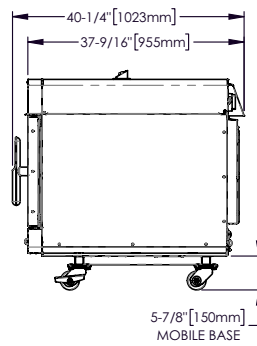
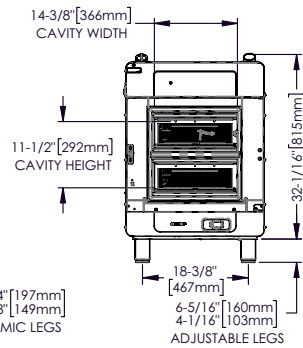
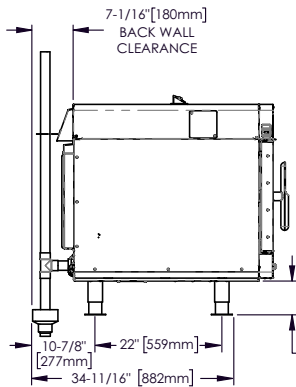
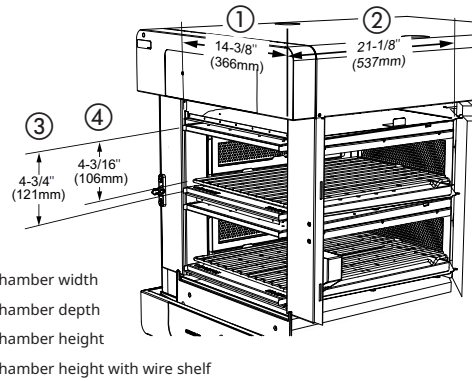
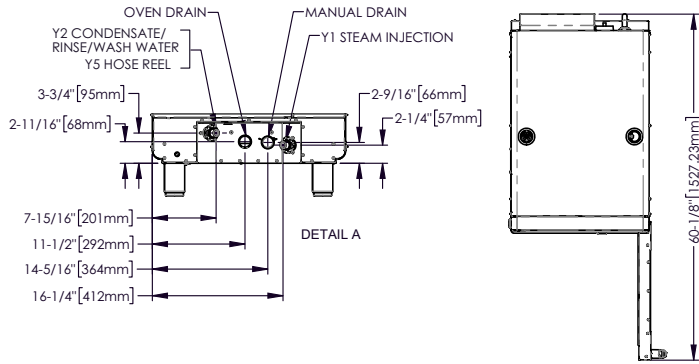

INSTALLATION

INSTALLATION

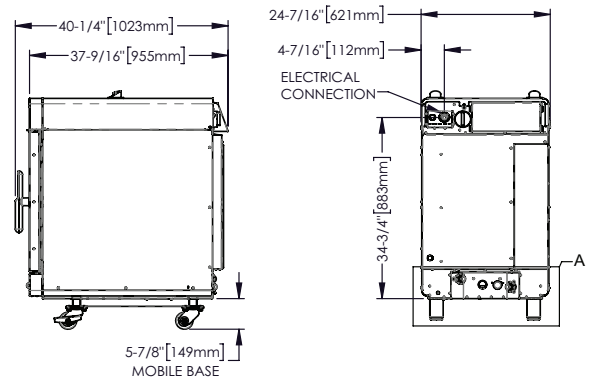
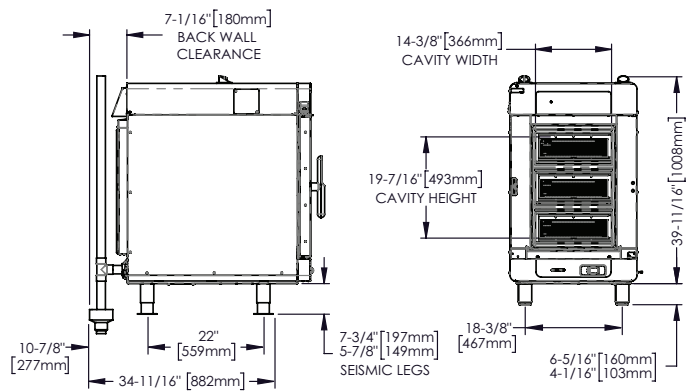
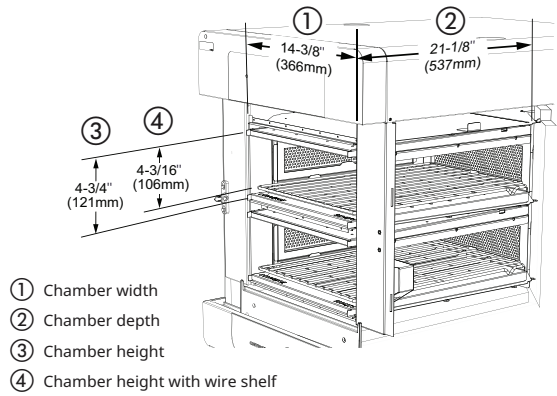
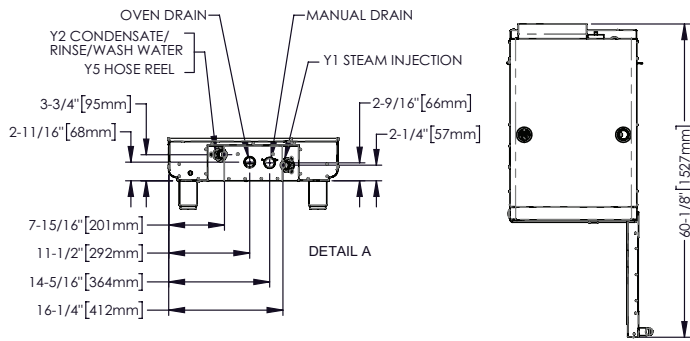

How to Unpack the Oven

Before you begin

Make sure you have:

- An appropriate lifting device and enough personnel to safely move and position the weight of the oven.
 - CMC-H2H: 304 lb (138 kg)
 - CMC-H3H: 394 lb (179 kg)
- Cutting tools to remove the packaging.

Unpack the oven

To unpack the oven, do the following.

Step	Action
1.	Remove the box. Save all packing materials for inspection by the carrier.
	<div style="border: 1px solid gray; padding: 5px;"> <p> NOTE: Examine the appliance for damage. If the appliance has been damaged, do not use the appliance until it has been inspected by an authorized service provider. Contact your carrier or Alto-Shaam customer service.</p> </div>
2.	Remove the shrink wrap.
3.	Cut the restraining straps.
4.	Remove the probe from the foam block.
5.	Remove the foam from each chamber.
6.	Remove the oven from the pallet.
7.	Remove the protective paper from the outside of the oven.

Result

The oven is now unpacked.

How to Install the Water Supply and Drain

Before you begin



NOTE: Refer to the detailed instructions that come with the installation kit.

NOTICE

Significant damage to the appliance cavity, elements, or heat exchanger could result from improper water quality. Failure to meet the water quality requirements will void the warranty.

NOTICE

Do not install a stacked set of ovens or a floor standing oven directly over a drain. Steam rising from the drain may adversely affect operation and damage electrical components.

Exception:

An oven on a stand that includes a solid bottom or solid shelf may be installed directly over a drain because the shelf or solid bottom will prevent steam from entering the oven.

Make sure:

- The supply lines are flexible to allow the oven to be moved when service or cleaning is needed.
- For units under IEC/EN jurisdiction: This appliance is intended to be permanently connected to the water mains. Comply with local codes when installing this appliance.
- The incoming water supply is shut off when the oven is not being used.

Requirements

Water requirements:

- Two (2) water inlets, drinking quality.
- One treated water inlet: 3/4" NPT male connection. Line pressure 30 psi (200 kPa) minimum dynamic and 145 psi (1000 kPa) maximum static at a minimum flow rate of 0.16 gpm (0.6 L/min).
- One untreated water inlet: 3/4" NPT male connection. Line pressure 30 psi (200 kPa) minimum dynamic and 145 psi (1000 kPa) maximum static at a minimum flow rate of 4.0 gpm (15 L/min).
- Water temperature range: 50°–140°F (10°–60°C)
- One (1) 3/4" ID water supply shut-off valve and back-flow preventer per oven where required by local code.
- Water drain: 1-1/2" No HUB connection with air gap at floor. Materials must withstand temperatures up to 200°F (93°C).
- Drain may not be directly below oven.

Continued on next page

Continued from previous page

It is the responsibility of the operator to make sure the incoming water supply is tested and meets the compliance requirements with the published water quality standards listed below. Non-compliance could damage the oven and void the warranty. Alto-Shaam recommends using OptiPure products to treat the water.

Contaminant	Treated Water	Untreated Water
Free Chlorine	less than 0.1 ppm (mg/L)	less than 0.1 ppm (mg/L)
Hardness	30–70 ppm	30–70 ppm
Chloride	less than 30 ppm (mg/L)	less than 30 ppm (mg/L)
pH	7.0–8.5	7.0–8.5
Silica	less than 12 ppm (mg/L)	less than 12 ppm (mg/L)
Total Dissolved Solids (TDS)	50–125 ppm	50–360 ppm

Installing the water supply

To install the water supply, do the following.

Step	Action
1.	Flush the water line at the installation site.
2.	Install adequate backflow protection to comply with applicable federal, state, and local codes.
3.	Remove the two adapter fittings on the water inlets.

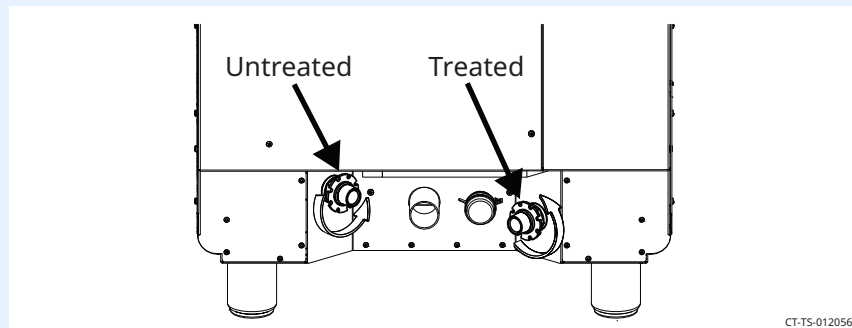

CT-TS-012056

Continued on next page

Continued from previous page

4. **Apply** thread sealant to the threads of the adapter fittings.
Install the elbow from the kit onto the adapter fitting.

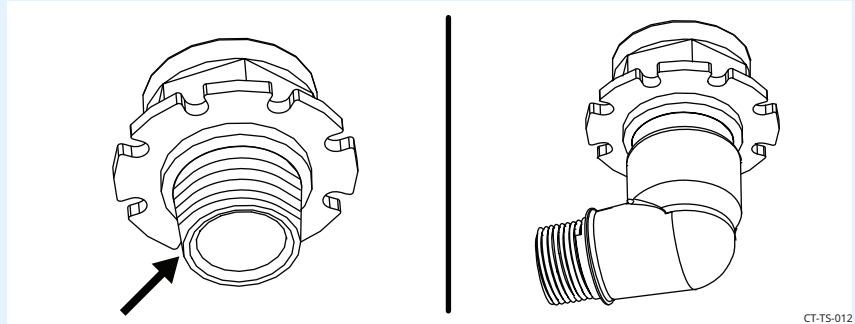

5. **Install** the adapter fittings and elbows onto the water inlets with slip joint pliers. **Tighten** the fittings until the elbows have a slight downward angle.

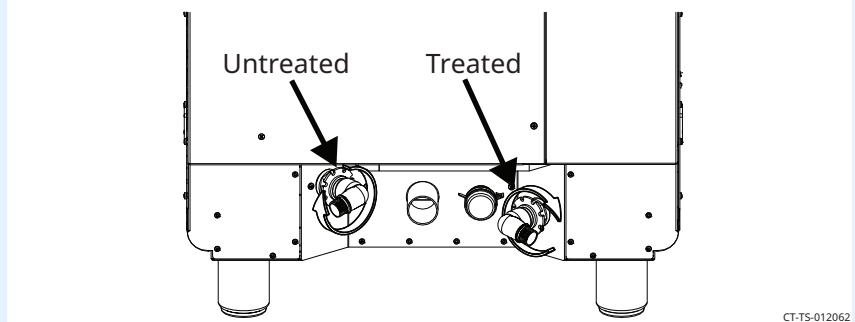

6. **Install** the water hoses onto the elbows.

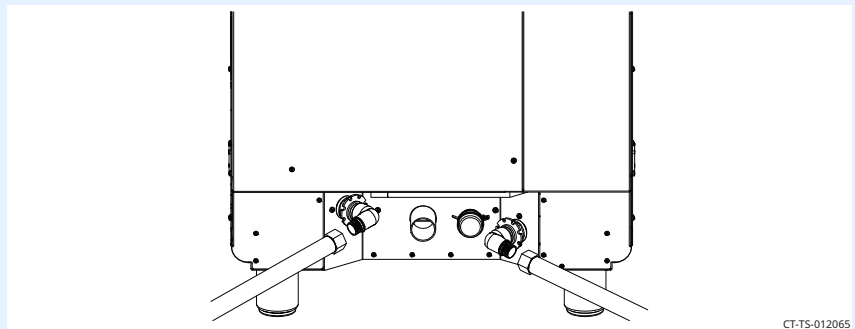

Continued on next page

Continued from previous page

Installing the water drain

Install a 1-1/2" (40mm) diameter connection, drain line and clamp into place. The drain line must always slope downward away from the oven. An end-of-drain air gap may be required by local code. Vertical air vent required.

NOTICE

In the U.S.A., this equipment must be installed to comply with the Basic Plumbing Code of the Building Officials and Code Administrators International, Inc. (BOCA), and the Food Service Sanitation Manual of the Food & Drug Administration (FDA).

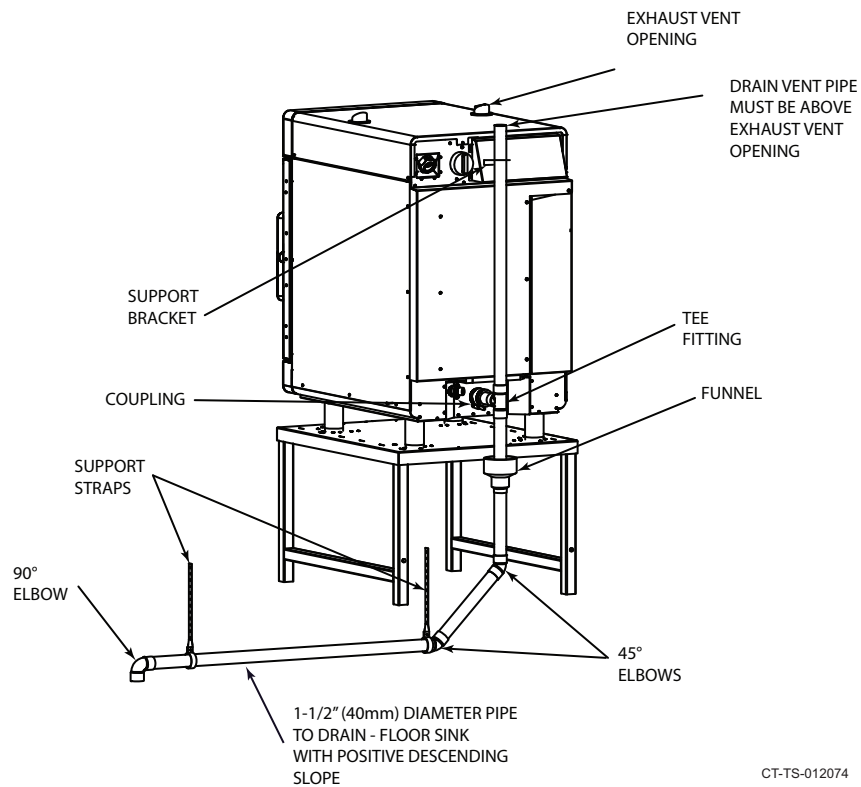

Continued on next page

Continued from previous page

To install the water drain, do the following.

7. **Drill** a hole for the mounting bracket using the dimensions in the image.
Install a screw into the drilled hole. Drill a hole for the second mounting screw. Install the screw.

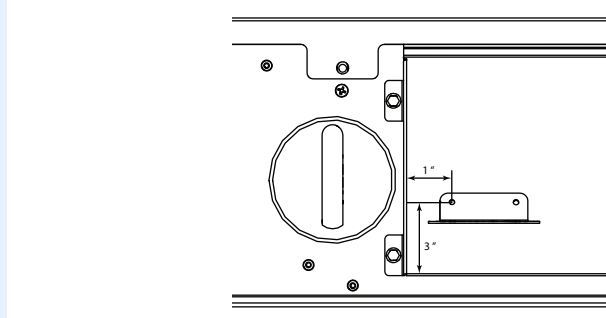

CT-TS-012077

8. **Install** the no hub coupling onto the over drain.
Cut a short piece of drain pipe. **Install** the pipe into the Tee fitting from the kit. **Install** the pipe and Tee fitting into the no hub coupling.

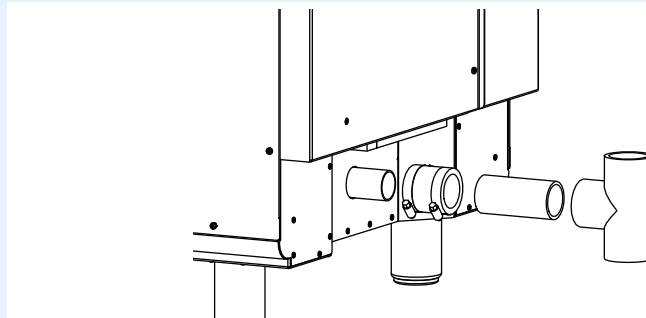

CT-TS-012080

9. **Install** the vent pipe into the Tee fitting.

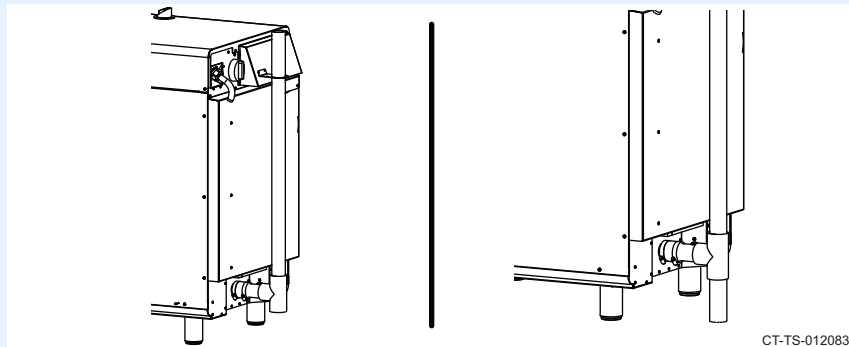

CT-TS-012083

Continued on next page

Continued from previous page

10. **Install** the remaining drain pipe.
Secure the drain with the clamps from the kit.

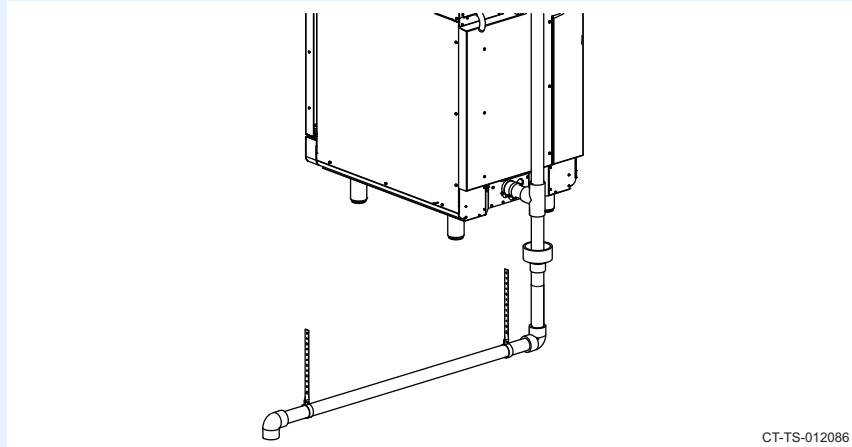

Result

The water supply and drain are now installed.

How to Install the Oven (60 Hz Cord and Plug Models)

Before you begin

Make sure you have:

- An appropriate lifting device, and enough personnel, to safely move and position the weight of the oven.
 - CMC-H2H: 304 lb (138 kg)
 - CMC-H3H: 394 lb (179 kg)

Requirements

- The oven must be installed on a level surface.
- The oven must not be installed in any area where it may be affected by steam, grease, dripping water, high temperature, or any other severely adverse conditions.
- The oven is not intended for built-in installation.

Voltages

	V	Ph	Hz	A	Breaker*	kW	Plug Configuration**
CMC-H2H	208	1	60	32	50	6.7	NEMA 6-50P
	240	1	60	37	50	8.9	NEMA 6-50P
	208	3	60	19	30	6.7	NEMA 15-30
	240	3	60	22	30	8.9	NEMA 15-30
CMC-H3H	208	3	60	28	50	10.1	
	240	3	60	32	50	13.4	

*Electrical connections must meet all applicable federal, state, and local codes.

**For use on individual circuit branch only.

Continued on next page

Continued from previous page

Position the oven

To position the oven, do the following.

Step	Action
1.	Make sure that:
	<ul style="list-style-type: none"> The location where the oven is being installed is rated to support the weight of the oven; The oven is within five feet (1.5m) of the appropriate electrical outlet; You follow the oven clearance guidelines.
	
2.	Move the oven to the installation location and onto the final resting surface.

1. **Make sure** that:

- The location where the oven is being installed is rated to support the weight of the oven;
- The oven is within five feet (1.5m) of the appropriate electrical outlet;
- You follow the oven clearance guidelines.

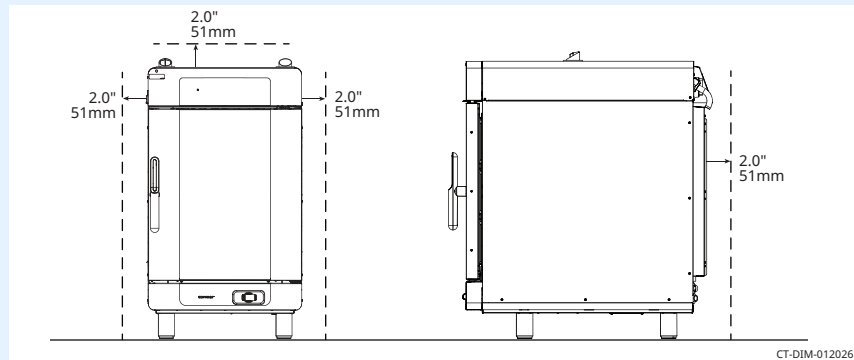

2. **Move** the oven to the installation location and onto the final resting surface.

The oven is now correctly positioned.

Level the oven

To level the oven, do the following.

3. **Check** the level of the oven using a spirit (bubble) level. Check front to back and side to side.

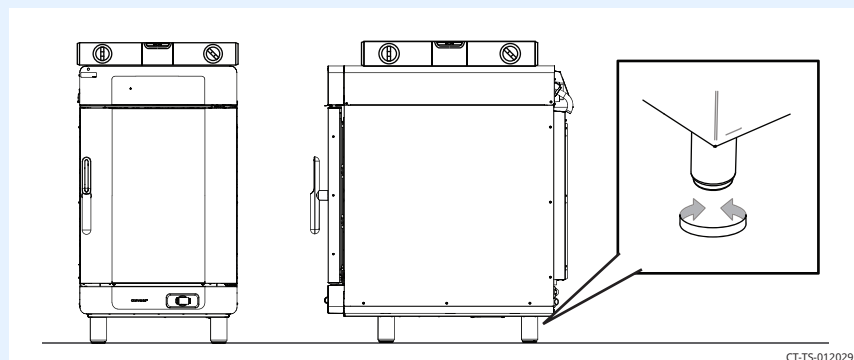

Adjust the legs, if necessary, to achieve levelness.

The oven is now correctly positioned.

Continued on next page

Continued from previous page

Connect power

To connect electric power to the oven, do the following.

4. **Set** the main disconnect switch ① to the OFF position.

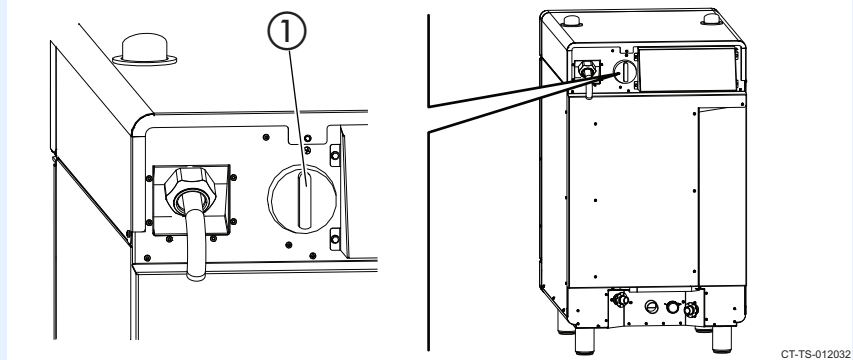

5. **Connect** the plug to the electrical outlet.

Press reset button(s)

6. **Press and release** the high limit temperature reset button(s) ②.

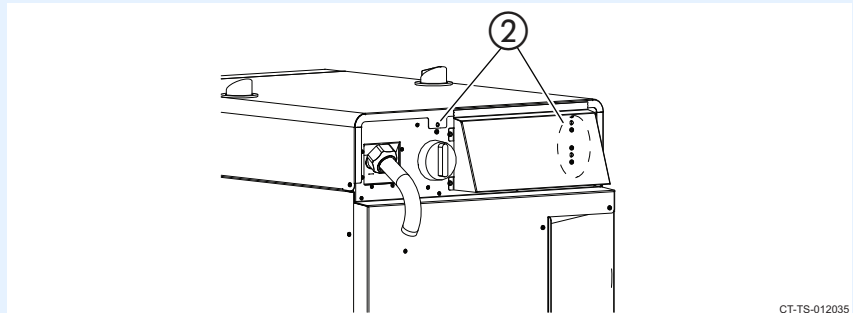

Result

The oven is now installed and ready to be used.

How to Install the Oven

(50 Hz Models Without Cord or Plug)

Before you begin

Make sure you have:

- An appropriate lifting device, and enough personnel, to safely move and position the weight of the oven.
 - CMC-H2H: 304 lb (138 kg)
 - CMC-H3H: 394 lb (179 kg)

Requirements

- The oven must be installed on a level surface.
- The oven must not be installed in any area where it may be affected by steam, grease, dripping water, high temperature, or any other severely adverse conditions.
- The oven is not intended for built-in installation.
- For 3-phase applications, an RCD Type B protection device must be installed. The device must accommodate a leakage current that may exceed 10 mA.
- If a power cord is used for the connection of the product, an oil resistant cord like H05RN or H07RN or equivalent must be used.

Voltages

	V	Ph	Hz	A	Breaker*	kW
CMC-H2H	380	3	50	11	30	7.5
	415	3	50	12	30	8.9
CMC-H3H	380	3	50	17	50	11.3
	415	3	50	19	50	13.4

*Electrical connections must meet all applicable federal, state, and local codes.

Continued on next page

Continued from previous page

Wire sizes

60335-1 IEC:2010

Rated current of appliance A	Nominal cross-sectional area mm ²
>0.2 - ≤3	0.5
>3 - ≤0	0.75
>6 - ≤10	1.0
>10 - ≤16	1.5
>16 - ≤25	2.5
>25 - ≤32	4
>32 - ≤40	6
>40 - ≤63	10

Position the oven

To position the oven, do the following.

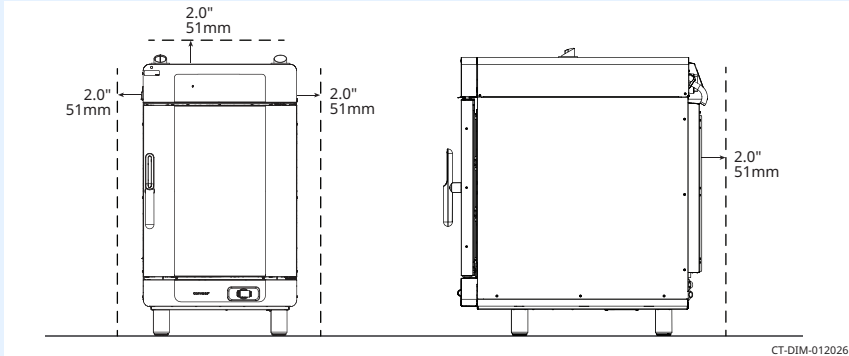
Step	Action
1.	<p>Make sure that:</p> <ul style="list-style-type: none"> ■ The location where the oven is being installed is rated to support the weight of the oven; ■ The oven is within five feet (1.5m) of the appropriate electrical outlet; ■ You follow the oven clearance guidelines.
	
2.	<p>Move the oven to the installation location and onto the final resting surface.</p>

The oven is now correctly positioned.

Continued on next page

Continued from previous page

Level the oven

To level the oven, do the following.

3. **Check** the level of the oven using a spirit (bubble) level. Check front to back and side to side.

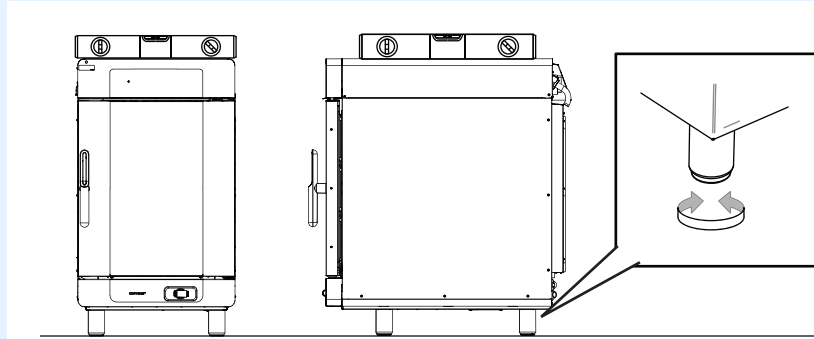

CT-TS-012029

Adjust the legs, if necessary, to achieve levelness.

The oven is now correctly positioned.

Connect the wiring

To connect the wiring, do the following.

4. **Remove** the pivot screws. **Remove** the top cover ①.



WARNING: Electric shock hazard.

Make sure the supply cord is not connected to a power supply.

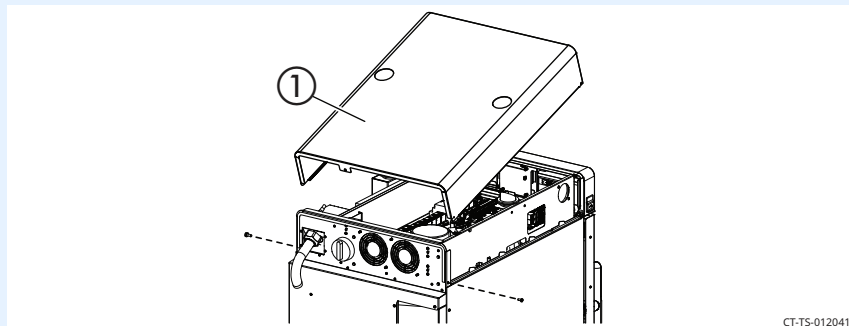

CT-TS-012041

Continued on next page

Continued from previous page

5. **Remove** the bottom 3 screws ② from the mounting bracket.
Remove the main disconnect switch ③ from the mounting bracket.

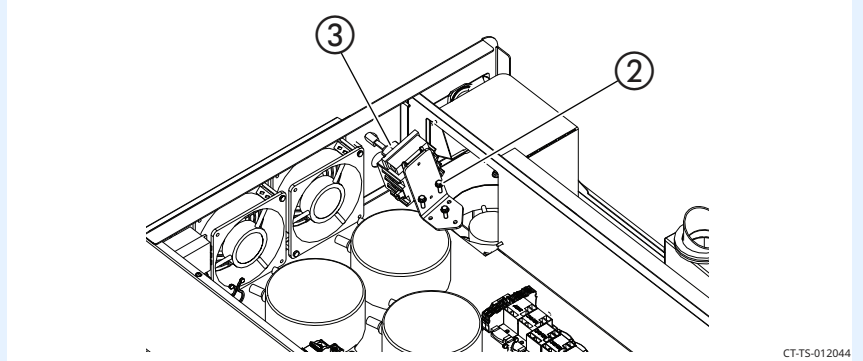

6. **Install** the cord ④ through the cord grip ⑤ and install in the oven.
- Install** the lock nut onto the cord grip.

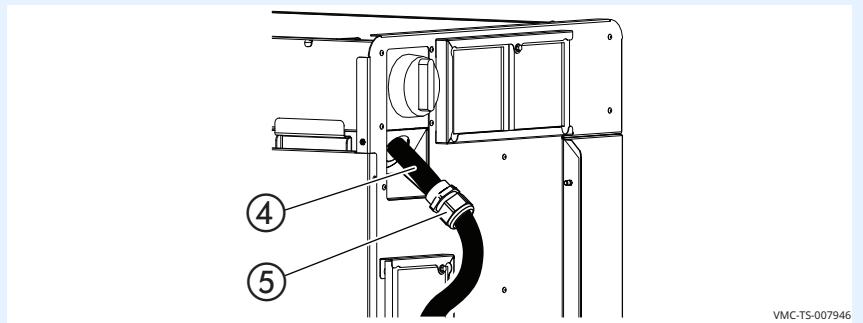

Continued on next page

Continued from previous page

7. **Connect** the supply cord to the appropriate terminals (L1, L2, L3, etc.) in accordance with local codes and regulations.

Install the ground wire ⑥.

Leave an extra loop ⑦ so that current-carrying conductors become taut before the ground wire if the cord is accidentally pulled. Follow applicable regulations.

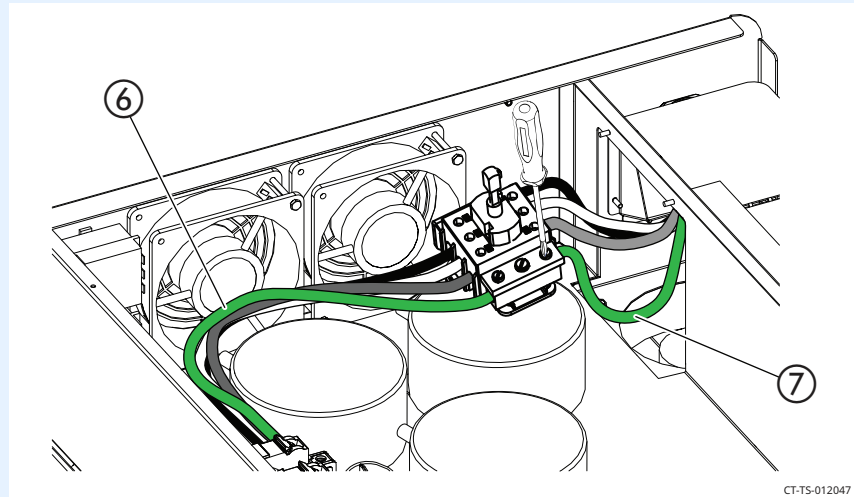

8. **Re-install** the main disconnect switch.
9. **Re-install** the mounting bracket.
10. **Re-install** the top cover.

Press reset button(s)

11. **Press and release** the high limit temperature reset button(s) ⑧.

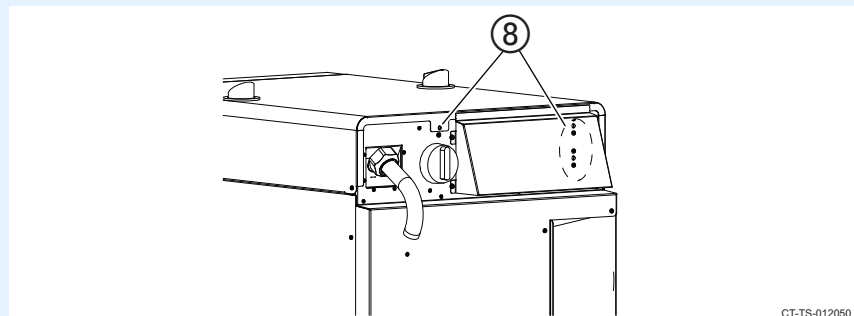

Result

The oven is now installed and ready to be used.

How to Install the Oven on a Stand

Before you begin

Make sure you have:

- The appropriate stand for your oven
- Regulation UL 197, 91.8
- A pop rivet gun and rivets
- An appropriate lifting device, and enough personnel, to safely move and position the weight of the oven.
 - CMC-H2H: 304 lb (138 kg)
 - CMC-H3H: 394 lb (179 kg)

Procedure

To install the ovens on a stand, do the following.

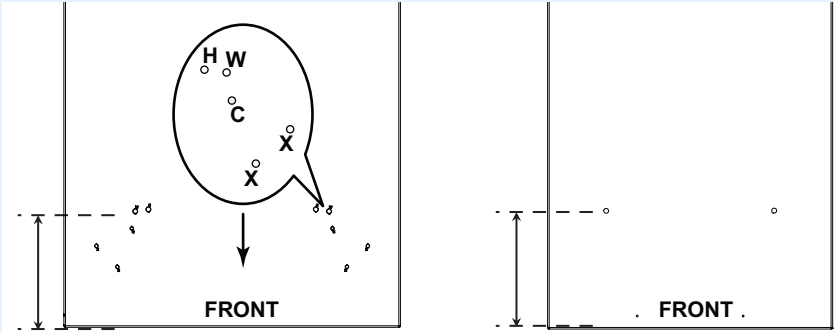
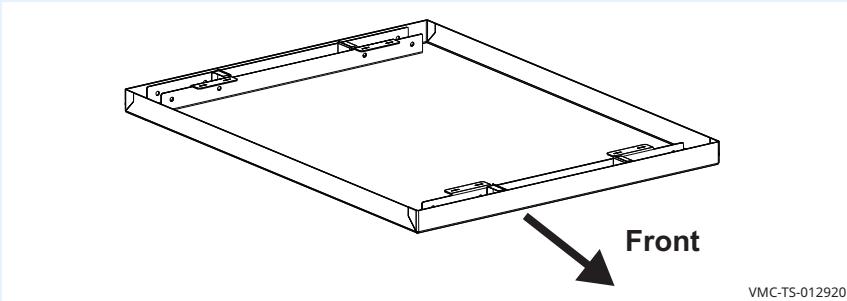
Step	Action
1.	<p>Locate the front of the top panel.</p>  <p style="text-align: right; font-size: small;">VMC-TS-012917</p>
2.	<p>Put the top upside down on a flat surface.</p>  <p style="text-align: right; font-size: small;">VMC-TS-012920</p>

Continued on next page

Continued from previous page

3. **Install** the leg assembly into the top panel.

Attach the leg assembly to the top panel with bolts and lock washers.

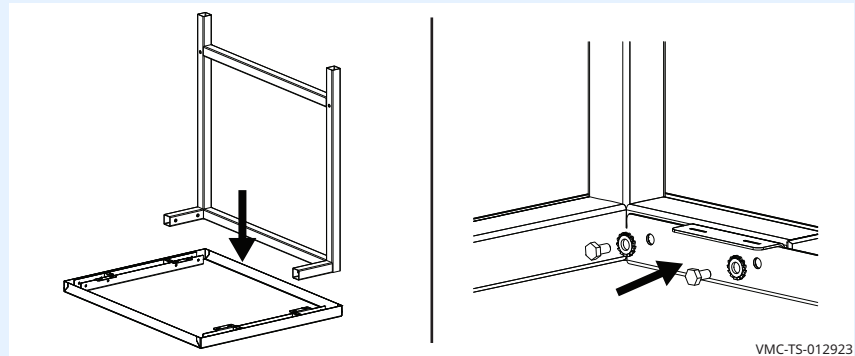

4. **Install** the second leg assembly into the top panel.

Attach the leg assembly to the top panel with bolts and lock washers.

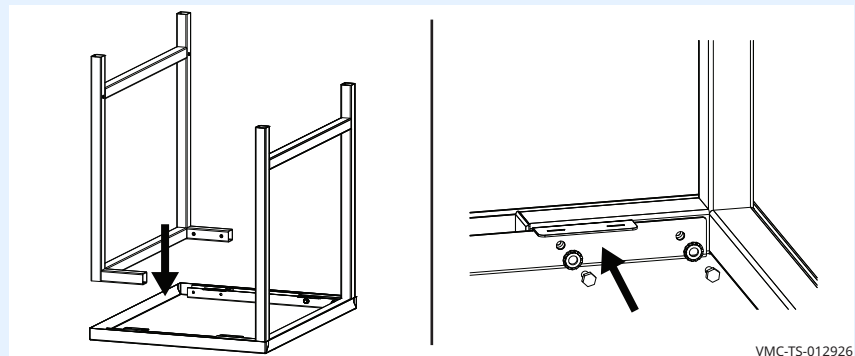

5. **Install** the casters or the feet assemblies into the legs.

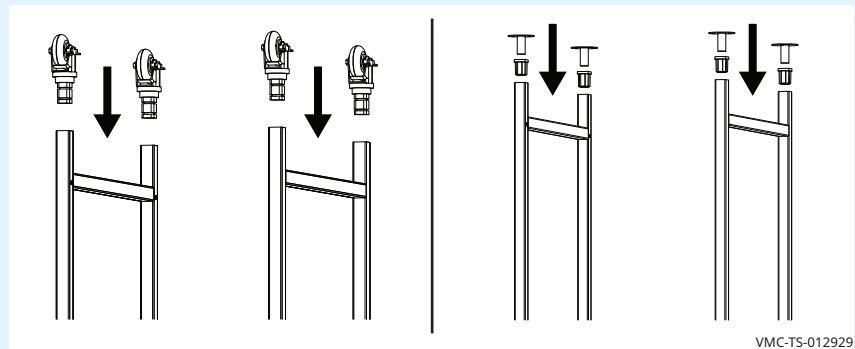

Continued on next page

Continued from previous page

Installing the shelf (optional)

6. **Determine** which way the slots are to be oriented.

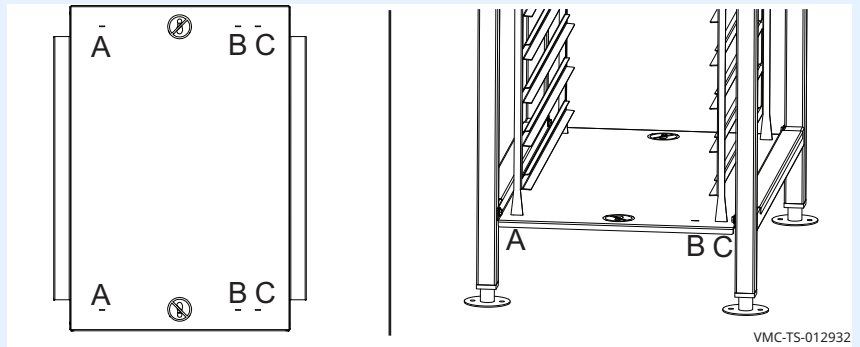

7. **Install** the shelf onto the leg assemblies.
Attach the shelf to the leg assemblies with bolts and lock washers.

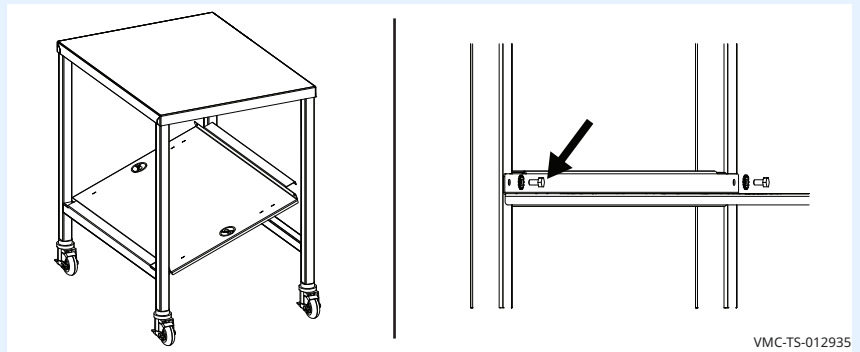

Installing the racks (optional)

8. **Install** the rack into the slots on the underside of the top.

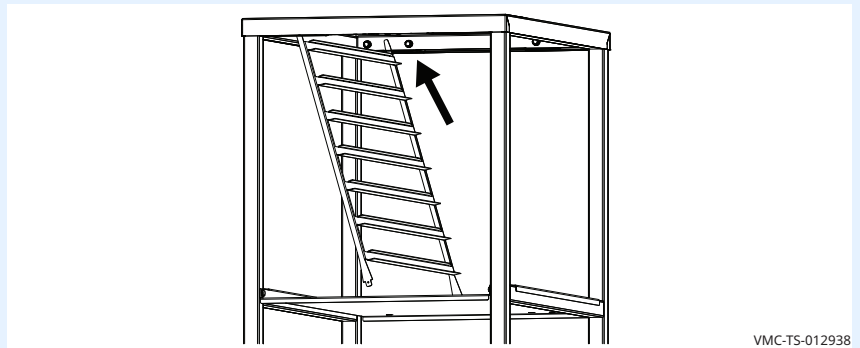

Continued on next page

Continued from previous page

9. **Rotate** the rack and lower it into the slots on the shelf.
Attach the rack to the shelf with cotter pins.

NOTE: Expand the cotter pin after inserting it through the hole.

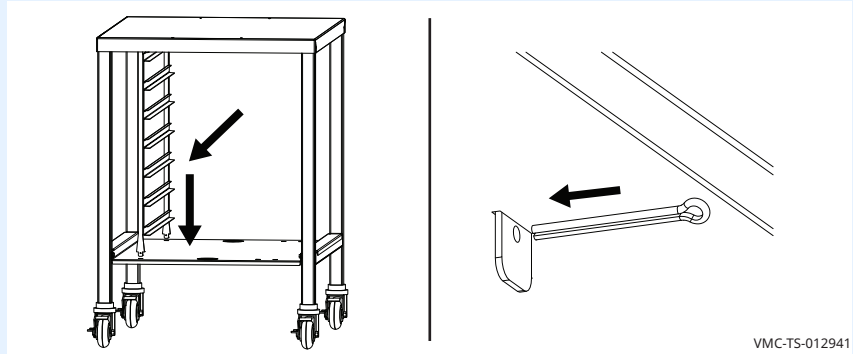

10. **Repeat** the process for the other rack.

11. **Locate** the holes in the top of the stand with the letter "C" etched next to them.

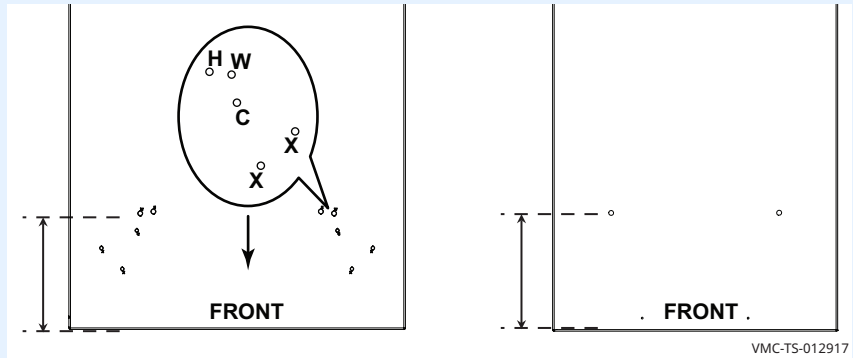

Installing the support channels

Continued on next page

Continued from previous page

12. **Place** the support channels onto the top of the stand. Line up the holes in the channels with the holes in the top of the stand.

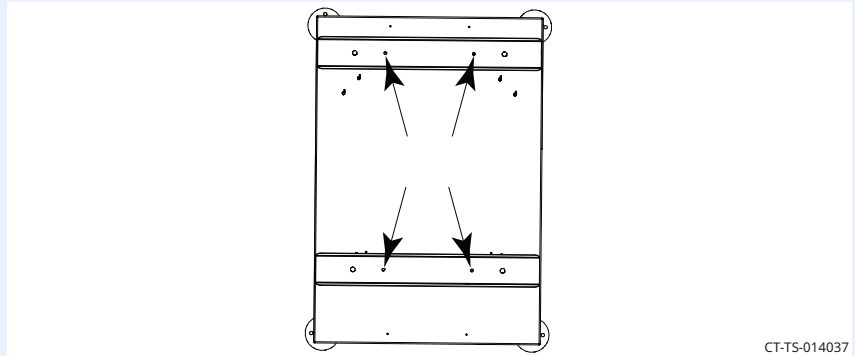

13. **Rivet** the channels to the top of the stand.

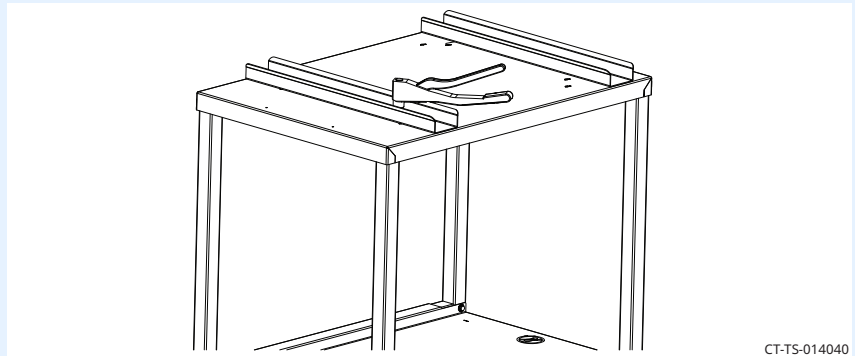

14. **Install** the pins through the channels and the top of the stand. **Secure** the pins with nuts.

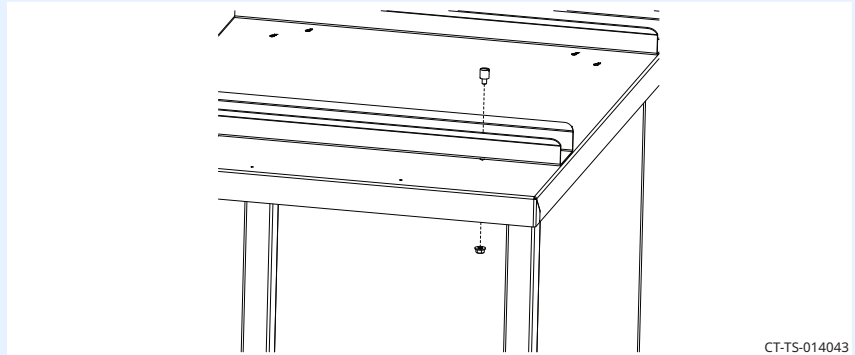

Continued on next page

Continued from previous page

Installing the oven on a stand

15. **Lift** the oven using an appropriate lifting device.

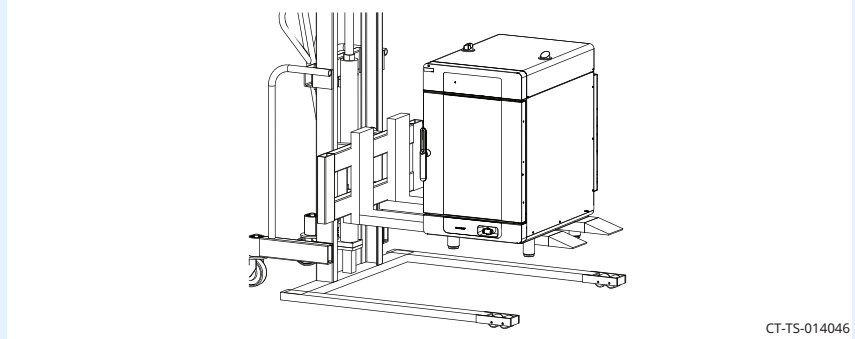

16. **Place** the oven on the stand. Position legs on the outside of the pins.

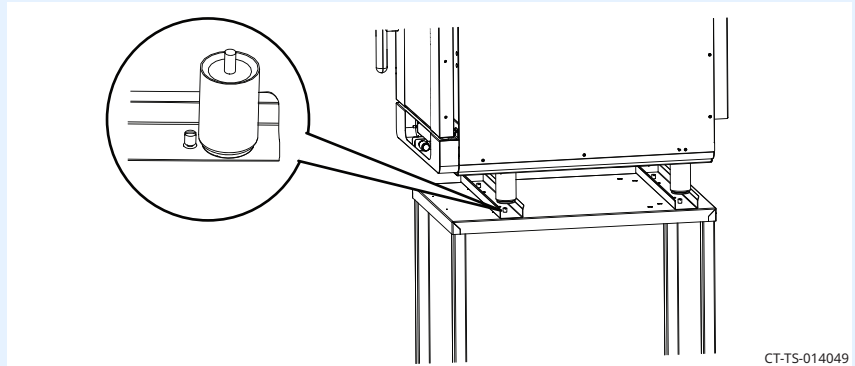

Result

The oven is now installed to the stand.

How to Install the Jet Plates

Background

Each jet plate assembly consists of one inner panel and one outer panel. There are two unique jet plate assemblies used on the Converge oven. The difference is in the outer panel used. One type (5034275) is used on the lower section of each chamber. The other type (5029717) is used on the upper section of each chamber. The inner panels used are the same for both types of assemblies.

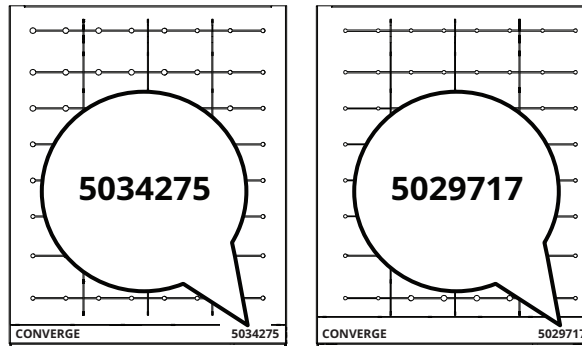

CT-TS-016595

Procedure

To install the jet plates, do the following.

Step	Action
1.	Each outer panel has the part number etched into the right corner. Locate the part number on all outer panels. Place an outer panel on a table with the part number facing up.

CT-TS-016599

Continued on next page

Continued from previous page

2. **Place** an inner panel on the table with the air deflector up.

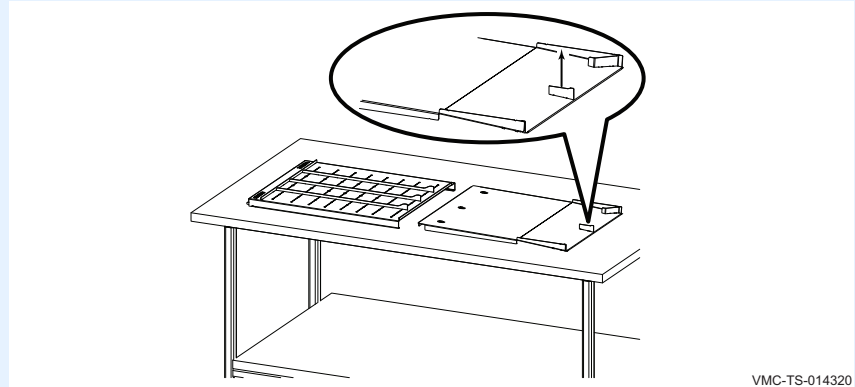

3. **Insert** the inner panel into the outer panel. **Push** the inner panel into the outer panel until it is fully inserted.

Assemble all jet plates in a similar fashion.

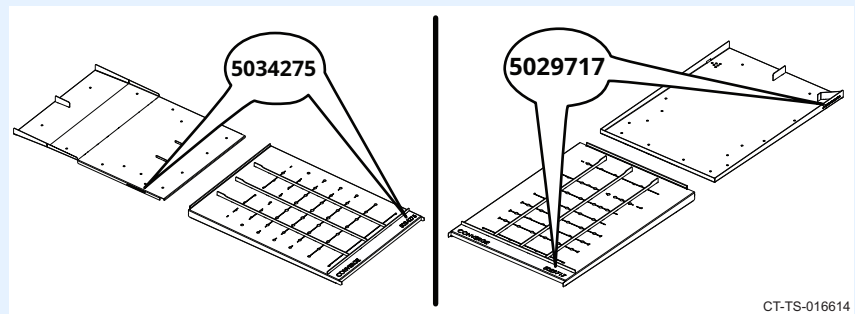

Continued on next page

Continued from previous page

4. **Install** jet plates 5034275 in the lower section of each chamber with the part number facing up. **Install** jet plates 5029717 in the upper section of each chamber with the part number facing down.

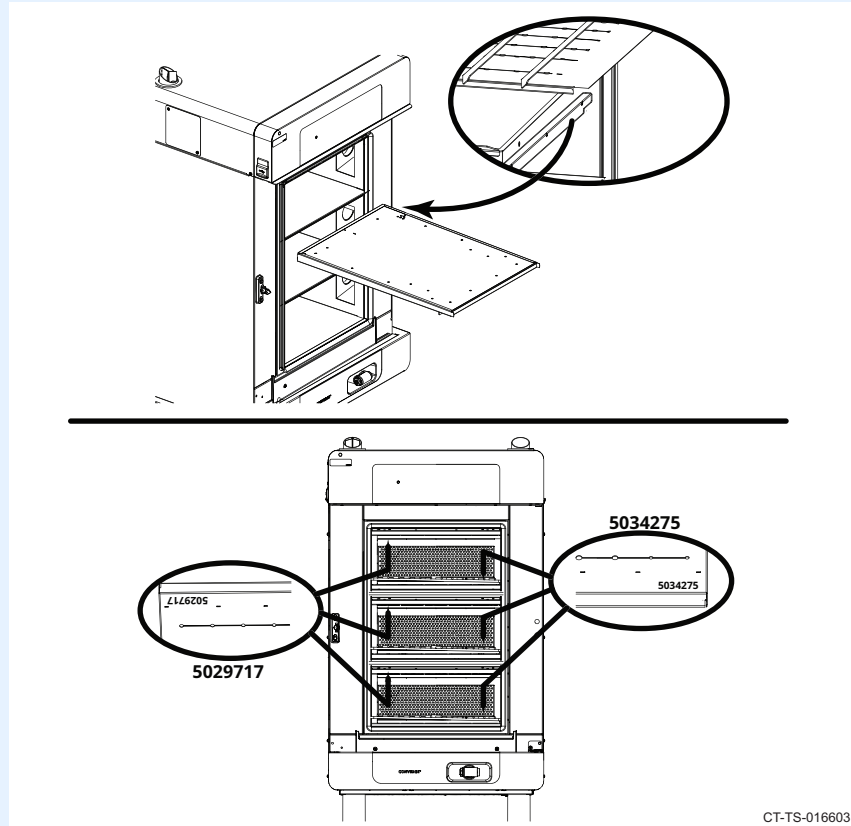

CT-TS-016603

Result

The jet plates are now installed.

How to Turn On and Turn Off the Oven

Before you begin

The oven must be connected to electric power.

Turning on the oven

To turn on the oven, do the following.

Step	Action
1.	<p>Set the main disconnect switch ① to the ON position.</p> <p>Press the ON/OFF button ②.</p> <div data-bbox="597 619 1339 724" style="border: 1px solid black; padding: 5px; margin: 10px 0;"> <p>i NOTE: The main disconnect switch is meant to be used during service operations. For every day operation, it may be left in the ON position.</p> </div> <div data-bbox="544 745 1388 1081" style="display: flex; justify-content: space-around;">   </div>
2.	<p>Press and hold the ON/OFF button ② until the “Shut Down Options” screen displays. Touch “Shut Down” ③. The oven activates the blowers for the cool-down process. The cool-down process is complete when the oven deactivates the blowers and the display screen turns off.</p> <div data-bbox="544 1428 1388 1764" style="display: flex; justify-content: space-around;">  </div>

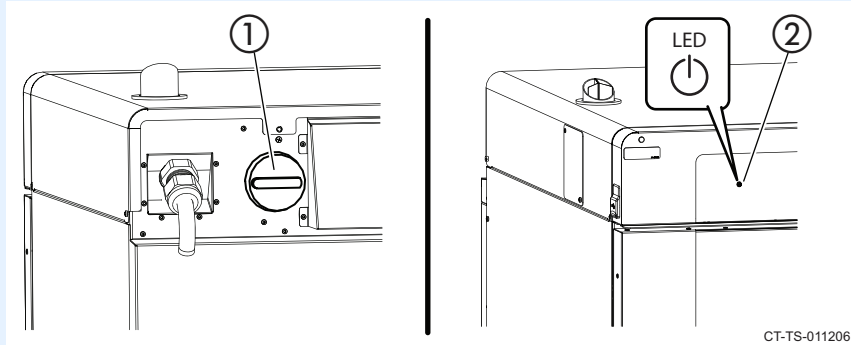

CT-TS-011206

The oven is now on.

Turning off the oven

To turn off the oven, do the following.

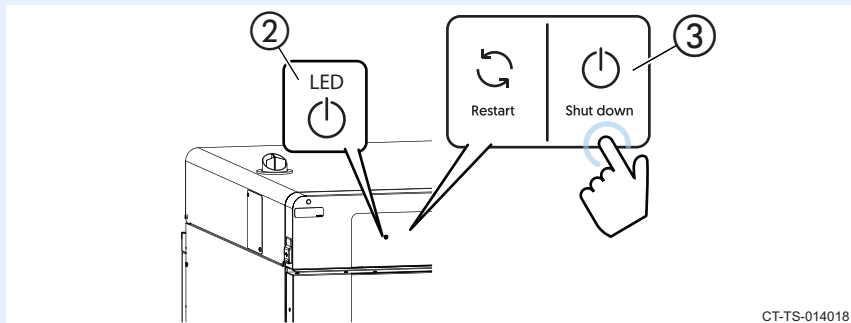

CT-TS-014018

The oven is now off.

How to Preheat the Oven

Before you begin

Make sure:

- The oven is turned on.
- The oven door is closed.

Procedure

To preheat the oven, do the following.

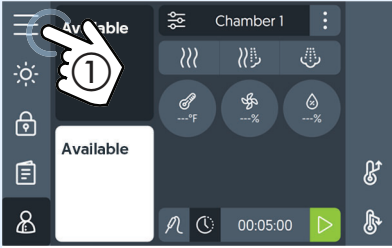
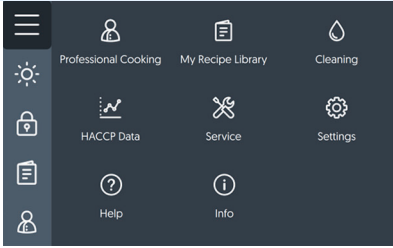
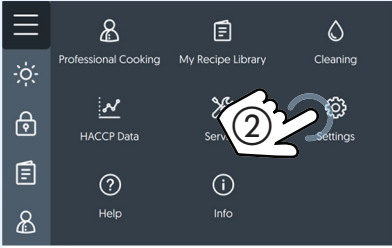
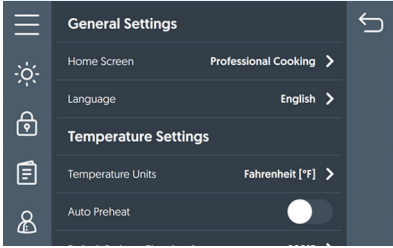
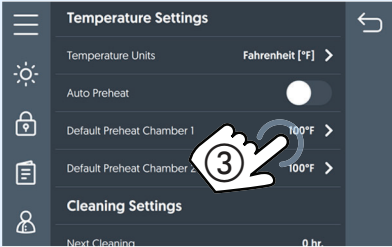
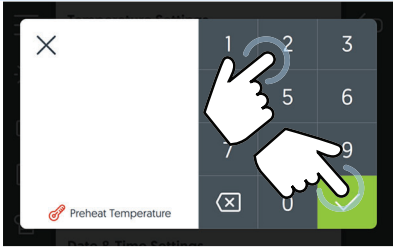
Step	Action
1.	<p>Touch the menu icon ①. The menu screen displays.</p>   <p style="text-align: right;"><small>CT-TS-014846</small></p>
2.	<p>Touch the “Settings” icon ②. The “General Settings” screen displays.</p>   <p style="text-align: right;"><small>CT-TS-014849</small></p>
3.	<p>Scroll to the “Temperature Settings.”</p> <p>Touch the preheat chamber settings for the chambers to be used ③. Enter the preheat temperature using the number pad. Touch the check mark.</p>   <p style="text-align: right;"><small>CT-TS-014896</small></p>

Continued on next page

Continued from previous page

4. **Touch** the check mark **④** to save the preheat temperature.
Touch the manual cook icon **⑤** to return to the manual cook screen.



5. **Touch** the preheat icon **⑥**. The preheat confirmation screen displays.
Touch "Preheat" **⑦**. All chambers start to preheat to their preset temperatures.

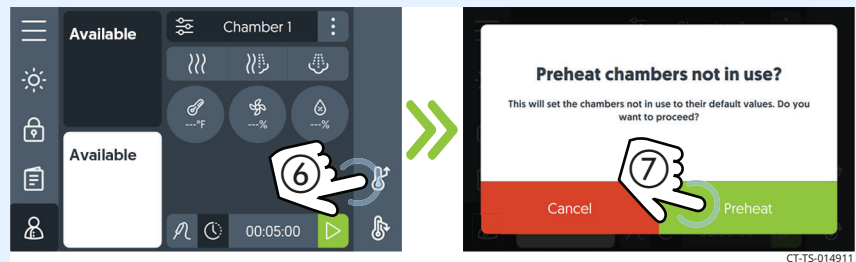

Screen loading bars

Loading bars indicate each chamber's progress towards reaching its set temperature.

Touch the cool down icon **⑧** to cancel the preheating process before the chambers reach their preset preheat temperature.

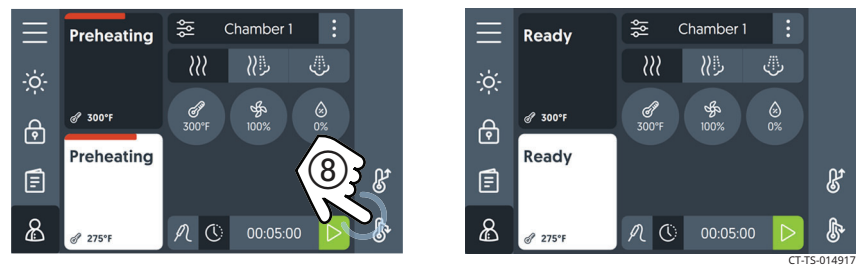

Result

The oven is preheating. When the preheat process is complete, the screen displays "Ready" for each chamber.

How to Cook with Programmed Recipes



Before you begin

Make sure:

- The oven is preheated.
- Your food is prepared and ready to cook.

Procedure

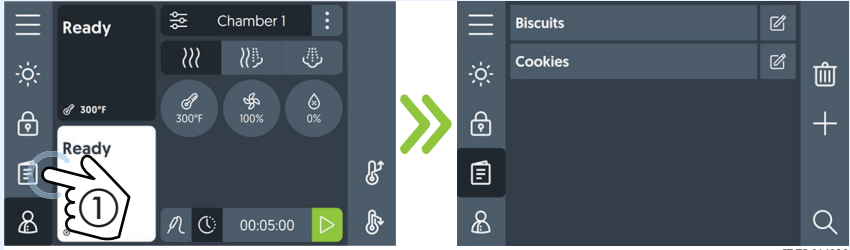
To cook using a programmed recipe, do the following.

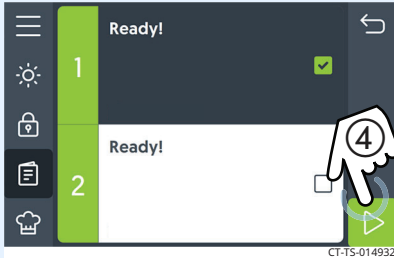
Step	Action
1.	<p>Touch the recipes icon ①. The browse recipes screen displays.</p>  <p style="text-align: right;"><small>CT-TS-014926</small></p>
2.	<p>Navigate to the recipe. Touch the recipe ②.</p> <p>Select the available chamber(s) ③.</p>  <p style="text-align: right;"><small>CT-TS-014929</small></p>
3.	<p>Open the door and load the food into the chamber. Close the door.</p> <p>Touch the start icon ④.</p>  <p style="text-align: right;"><small>CT-TS-014932</small></p>

Continued on next page

Continued from previous page

During the cooking process

The cooking status screen displays the details on the current cook setting.

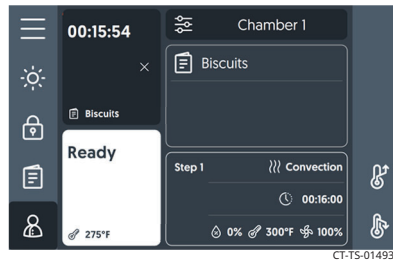

During the cooking process:

Action	Result
Touch the chamber...	to show the recipe details.
Touch "X"...	to cancel the cooking process.

Result

At the end of the cooking process, the oven sounds an alert and the chamber light flashes. Remove the cooked food.

How to Cook in Professional Mode

Before you begin

Make sure:

- The oven is preheated.
- Your food is prepared and ready to cook.

Background

This procedure consists of:

- setting the food loading action;
- and setting the cooking stage parameters (temperature, time, and fan speed).

Procedure

To cook in professional mode, do the following.

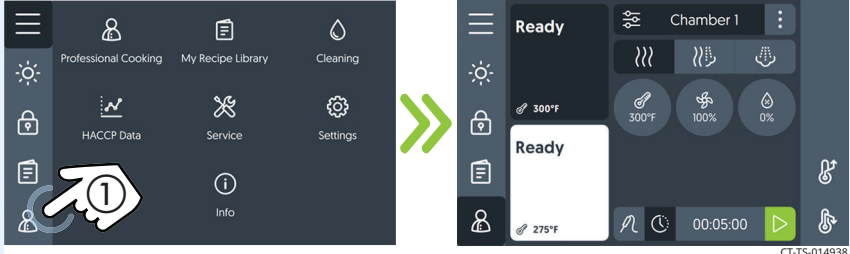
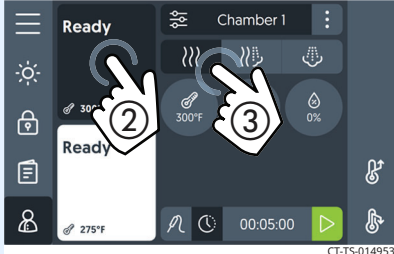
Step	Action
1.	<p>Touch the professional cook icon ①. The available chambers are displayed.</p> 
2.	<p>Touch any available chamber ②. Touch a cooking mode ③.</p> 

Continued on next page

Continued from previous page

Cooking by time

3. If cooking by time, **touch** the cook by time icon ④. Then, **touch** the cooking time ⑤. **Enter** the cooking time using the key pad. **Touch** the check mark.

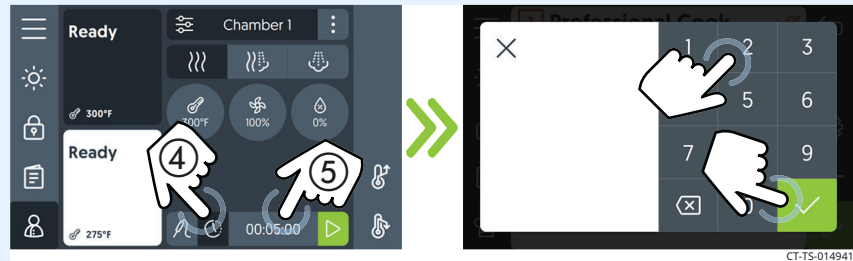

CT-TS-014941

Continuous cook

4. To set an indefinite cooking timer, **touch** the continuous cook icon ⑥. **Touch** the check mark.



CT-TS-015070

Cooking by probe

5. If cooking by probe, **touch** the cook by probe icon ⑦. Then, **touch** the probe temperature ⑧. **Enter** the probe temperature set-point using the key pad. **Touch** the check mark.

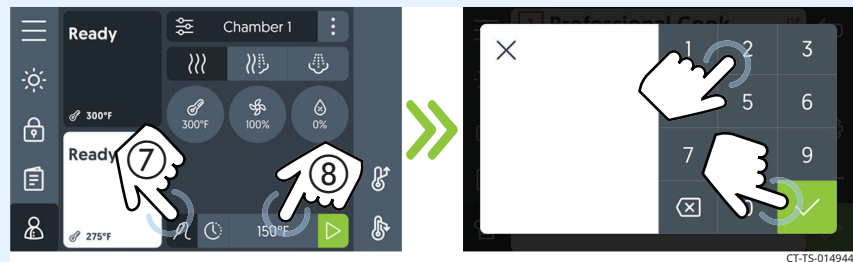

CT-TS-014944

Continued on next page

Continued from previous page

6. **Touch** the cooking temperature ⑨. **Enter** the cooking temperature using the key pad.

Touch the humidity percentage ⑩. **Enter** the humidity percentage using the key pad.

Touch the fan speed ⑪. **Enter** the fan speed using the key pad.



7. **Load** the food into the appropriate chamber.

8. **Touch** the start icon ⑫. The cooking stage timer starts to count down.

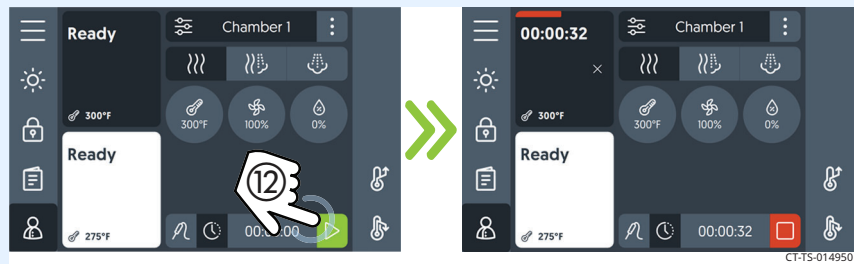

During the cooking process

Action	Result
Touch the chamber...	to show the recipe details.
Touch "X"...	to cancel the cooking process.

9. At the end of the cooking process, the oven sounds an alert and the chamber light flashes.

10. **Open** the door and remove the hot food.

NOTE: Be sure to remove the cooked food after the cooking process is complete. The oven will revert back to the preheat temperature. If left inside the oven, the food will continue to cook.

Result

The food is now cooked.

How to Use the Dual Timers

Before you begin

Make sure:

- The oven is preheated.
- Your food is prepared and ready to cook.

Background

There may be times when you will want to use the same chamber to cook two pans of food at the same time, but at different intervals. The dual timer function allows you to do so.

Procedure

To cook using the dual timers, do the following.

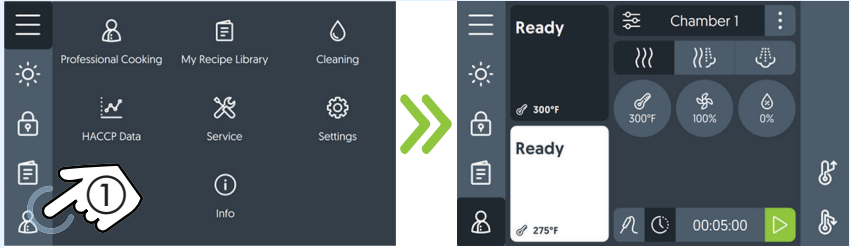
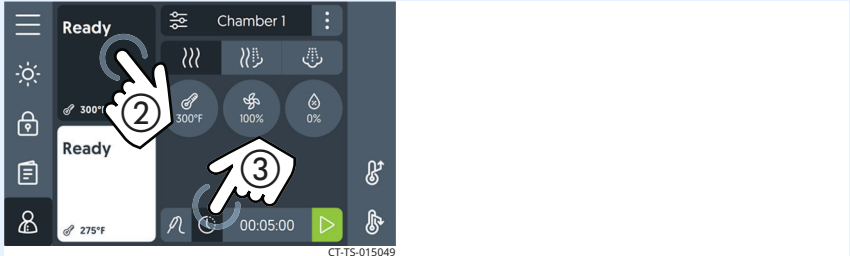
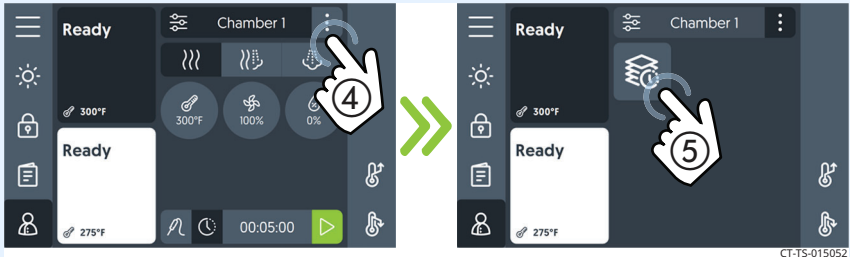
Step	Action
1.	<p>Touch the professional cook icon ①. The available chambers are displayed.</p>  <p>CT-TS-014938</p>
2.	<p>Touch any available chamber ②. Touch the cook by time icon ③.</p>  <p>CT-TS-015049</p>
3.	<p>Touch the chamber options icon ④. Then, touch the chamber multiple shelf icon ⑤.</p>  <p>CT-TS-015052</p>

Continued on next page

Continued from previous page

4. **Touch** the cooking time ⑥. **Enter** the cooking time using the key pad. **Touch** the check mark.

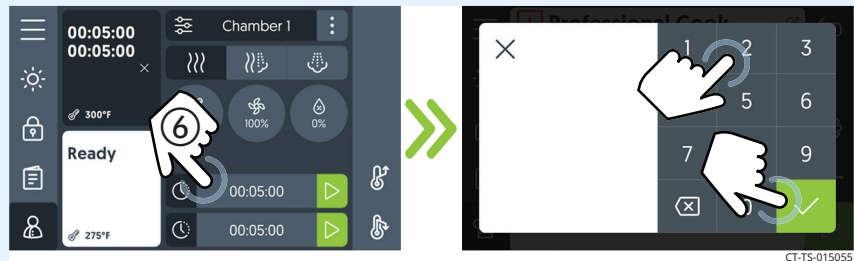

5. **Enter** the cooking time ⑦ for the second pan of food.

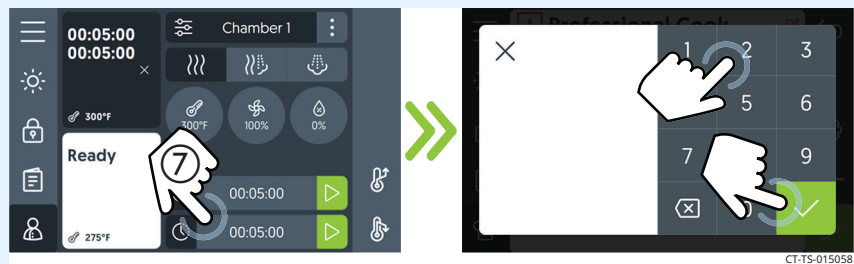

6. **Touch** the cooking temperature ⑧. **Enter** the cooking temperature using the key pad.
Touch the humidity percentage ⑨. **Enter** the humidity percentage using the key pad.
Touch the fan speed ⑩. **Enter** the fan speed using the key pad.

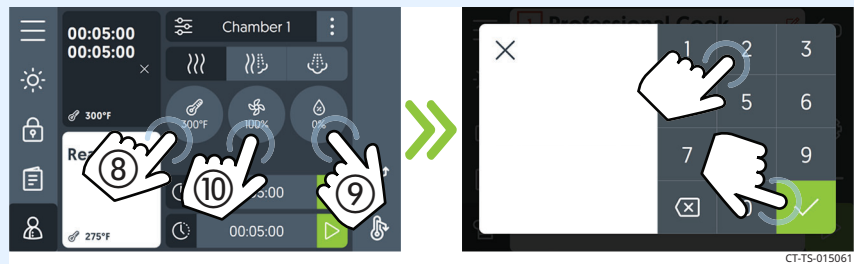

Continued on next page

Continued from previous page

7. **Load** pan 1 into the appropriate chamber.

Touch the start icon ⑪.

The cooking stage timer starts to count down for pan 1.

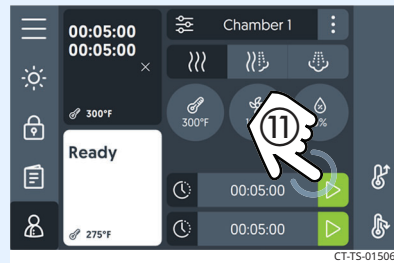

8. **Load** pan 2 into the appropriate chamber.

Touch the start icon ⑫.

The cooking stage timer starts to count down for pan 2.

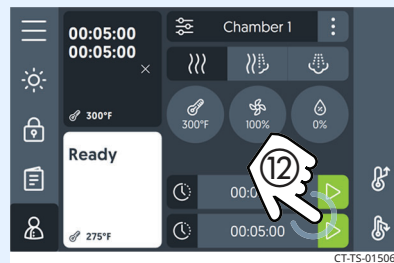

At the end of the cooking process, the oven sounds an alert and the chamber light flashes.

9. **Open** the door and remove the hot food.



NOTE: Be sure to remove the cooked food after the cooking process is complete. The oven will revert back to the preheat temperature. If left inside the oven, the food will continue to cook.

Result

The food is now cooked.

How to Lock and Unlock the Screen

Before you begin

The oven is turned on.

Background

The screen can be locked to prevent changes being made during the cooking process.

Procedure

To lock and unlock the screen, do the following.

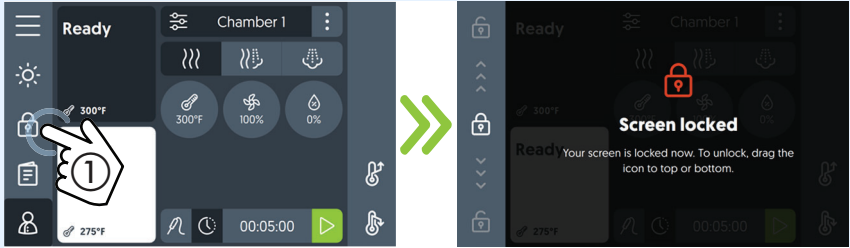
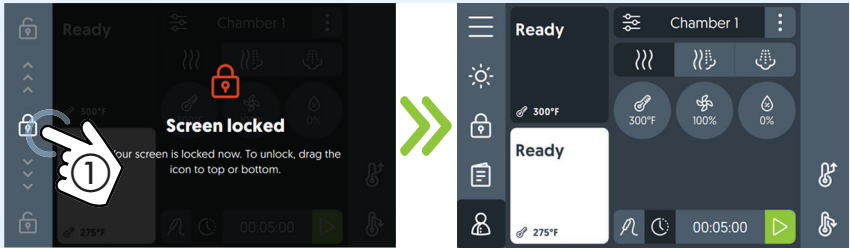
Step	Action
1.	<p>Touch the lock icon ①. The screen is now locked.</p>  <p>CT-TS-014956</p>
2.	<p>To unlock the screen, touch and hold the lock icon and drag it to the top or bottom of the screen.</p>  <p>CT-TS-014959</p>

Result

The screen is now locked or unlocked.

How to Cool Down the Oven

Procedure

To cool down the oven, do the following.

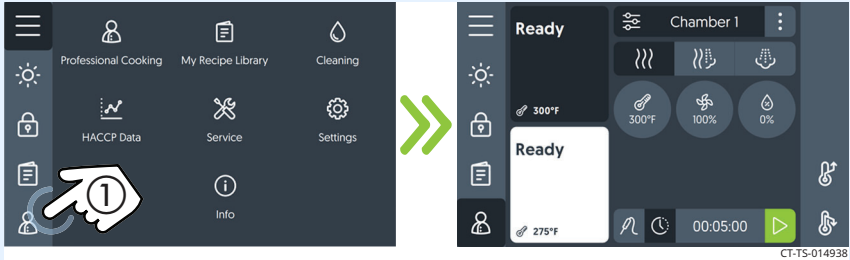
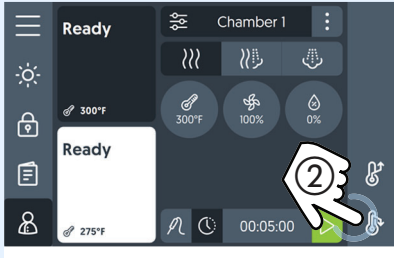
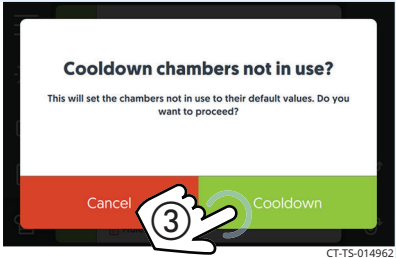
Step	Action
1.	<p>Touch the professional cook icon ①.</p> 
2.	<p>Touch the cooldown icon ②. The cooldown all chambers screen displays.</p> <p>Touch "Cooldown" ③. Open the door.</p> <div style="border: 1px solid black; padding: 5px; margin: 10px 0;"> <p>NOTE: The oven activates the blowers for the cooldown process. The oven deactivates the blowers when the cooldown process is complete.</p> </div>  

Cooling down progress bars

Above each chamber on the screen, blue progress bars indicate each chamber's progress towards reaching its cool down temperature.

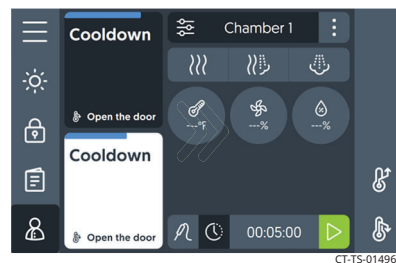

Result

The oven is now cooled down.

How to Create a Recipe



Background

Creating a recipe consists of:

- Setting the cooking stage(s) parameters (temperature, time, humidity percentage, and fan speed);
- setting an action step if desired such as adding an ingredient;
- naming the recipe;
- adding a description to the recipe;
- adding a photo to the recipe;
- and adding the recipe to a category.

Procedure

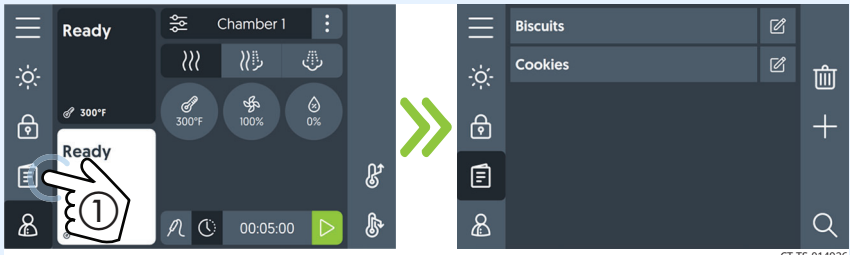
To create a recipe, do the following.

Step	Action
1.	<p>Touch the recipes icon ①. The browse recipes screen displays.</p>  <p style="text-align: right; font-size: small;">CT-TS-014926</p>
2.	<p>Touch the plus icon ②. The step type screen displays.</p>  <p style="text-align: right; font-size: small;">CT-TS-015004</p>

Continued on next page

Continued from previous page

3. **Touch** the step type icon ③ to choose the step type.

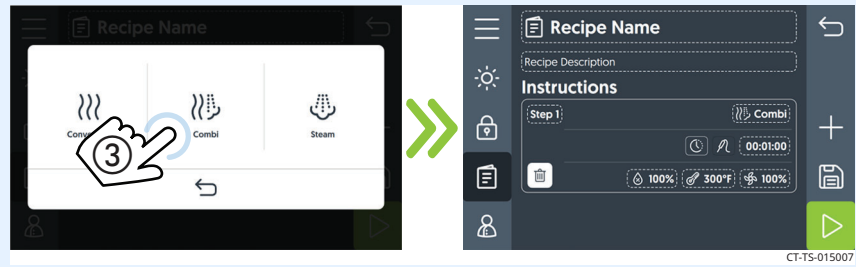

CT-TS-015007

4. **Touch** "Recipe Name" ④. The recipe name screen displays.



CT-TS-015010

5. **Enter** the recipe name. **Touch** the check mark icon ⑤ to return to the create recipe screen.



CT-TS-015013

Continued on next page

Continued from previous page

6. **Touch** "Recipe Description" ⑥. The "Recipe Description" screen displays. **Enter** the recipe description. **Touch** the check mark icon to return to the create recipe screen.



7. **Touch** the cook by time icon or cook by probe icon ⑦. **Touch** the cooking time or probe set-point temperature ⑧. **Enter** the cooking time or probe temperature using the key pad. **Touch** the check mark.

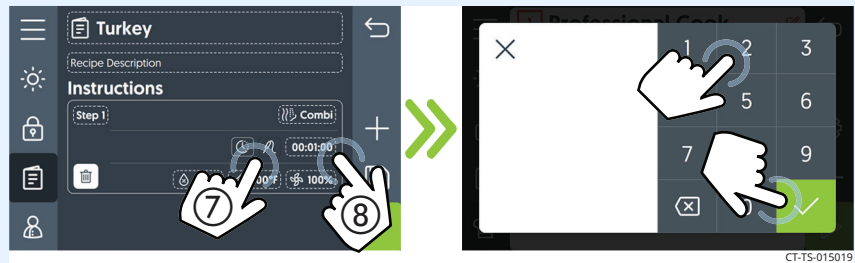

8. **Touch** the humidity icon ⑨. **Enter** the humidity percentage using the key pad. **Touch** the check mark.

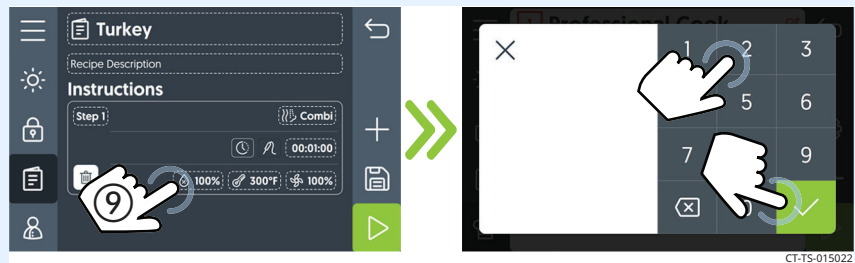

Continued on next page

Continued from previous page

9. **Touch** the chamber temperature set-point icon ⑩. **Enter** the chamber temperature set-point using the key pad. **Touch** the check mark.

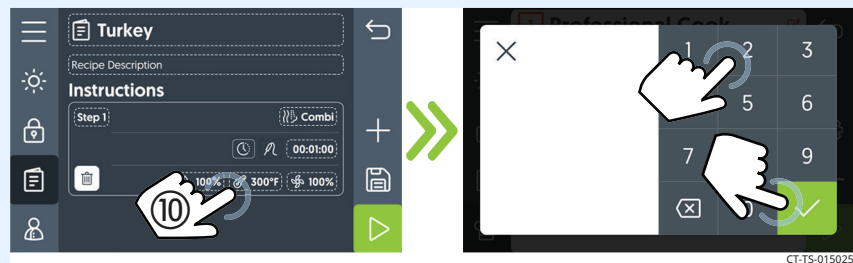

10. **Touch** the fan speed icon ⑪ to set the fan speed. **Touch** the check mark.



11. **Touch** the plus icon ⑫ to add an additional stage.
Touch the delete icon ⑬ to delete a stage.



12. **Touch** the save icon ⑭ when finished to save the recipe.



Result

A new recipe has been created.

How to Modify or Delete a Recipe

Procedure

To modify or delete a recipe, do the following.

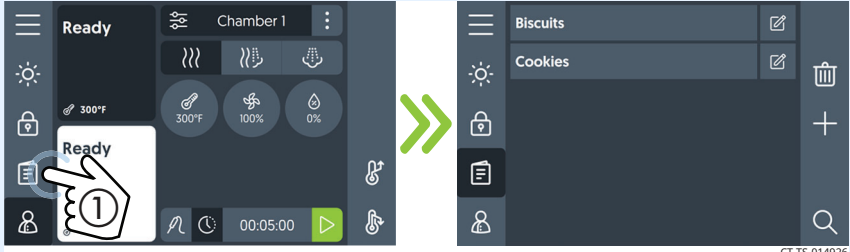
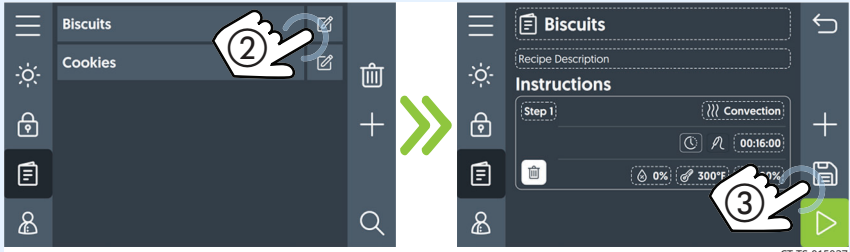
Step	Action
1.	<p>Touch the recipes icon ①. The browse recipes screen displays.</p>  <p>CT-TS-014926</p>
2.	<p>To modify a recipe, touch the recipe edit icon ② of the desired recipe.</p>  <p>CT-TS-015037</p> <p>The first stage of the recipe displays. There will be a screen for each stage. Scroll to the stage you want to modify.</p> <ul style="list-style-type: none"> ■ Touch the cook by time or cook by probe icon then modify the value using the key pad. ■ Touch the humidity icon to modify the humidity percentage. ■ Touch the chamber set-point icon to modify the chamber temperature. ■ Touch the fan speed icon to modify the fan speed. <p>Touch the save icon ③ when finished.</p> <p>Touch the trash icon to delete the stage, if desired.</p>

Continued on next page

Continued from previous page

Deleting

3. To delete a recipe, **touch** the delete icon ④.

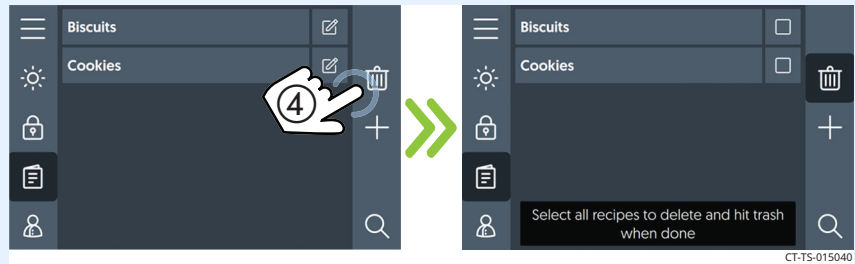

Select the recipe(s) that you want to delete. **Touch** the delete icon again.

Touch "Continue" to confirm that you want to delete the recipe(s).

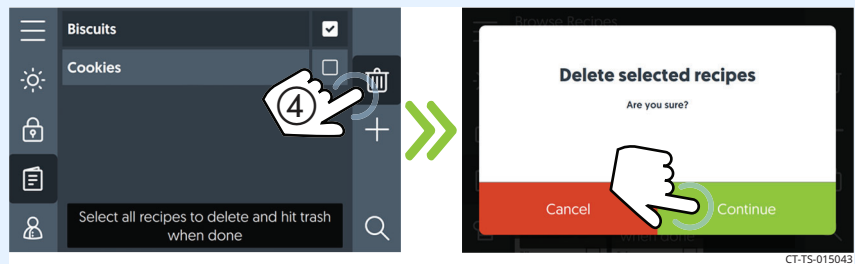

Result

The procedure is now complete.

How to Backup or Restore Settings with a USB Drive

Before you begin

Make sure:

- The oven is on, but not in a cooking mode.
- You will need a USB drive.

Procedure

To backup or restore settings with a USB drive, do the following.

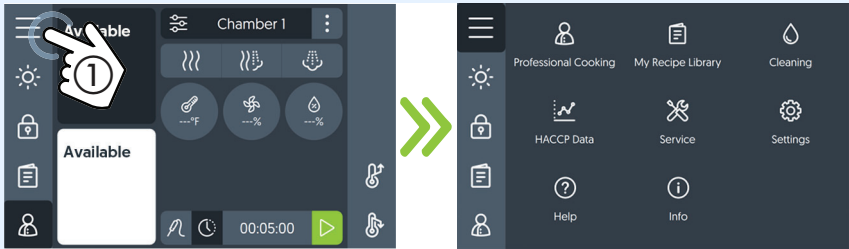
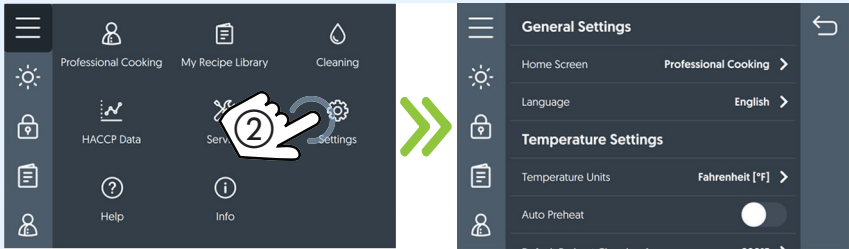
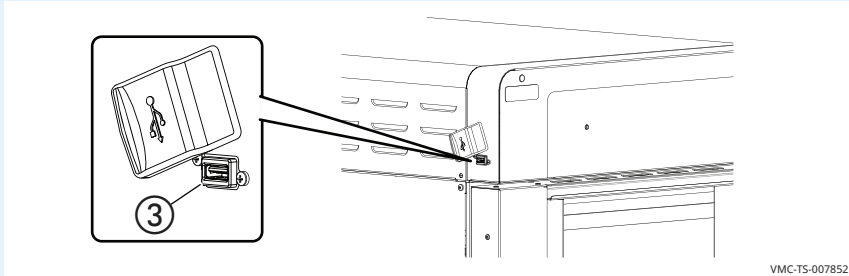
Step	Action
1.	<p>Touch the menu icon ①. The menu screen displays.</p>  <p style="text-align: right; font-size: small;">CT-TS-014846</p>
2.	<p>Touch the "Settings" icon ②. The "General Settings" screen displays.</p>  <p style="text-align: right; font-size: small;">CT-TS-014849</p>
3.	<p>Plug the USB drive ③ into the port.</p>  <p style="text-align: right; font-size: small;">VMC-TS-007852</p>

Continued on next page

Continued from previous page

4. **Scroll** to “System Backup & Update.”

Touch “Backup Settings to USB or “Restore Settings from USB” ④.



Loading the recipes

The oven downloads or restores the settings. When the process is complete, **touch** the check mark to return to the settings screen. **Remove** the USB drive.

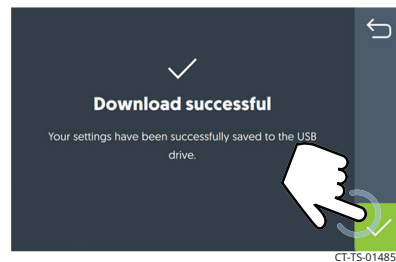

Result

The settings have now been saved to the USB drive or restored from the USB drive.

How to Load Recipes from a USB Drive

Before you begin

Make sure:

- The oven is on, but not in a cooking mode.
- You will need a USB drive loaded with recipes.

Procedure

To load recipes from the USB drive to the oven, do the following.

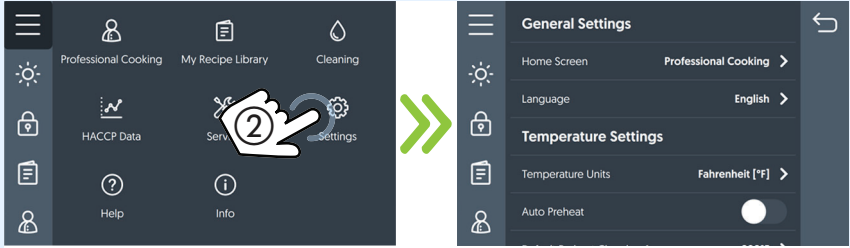
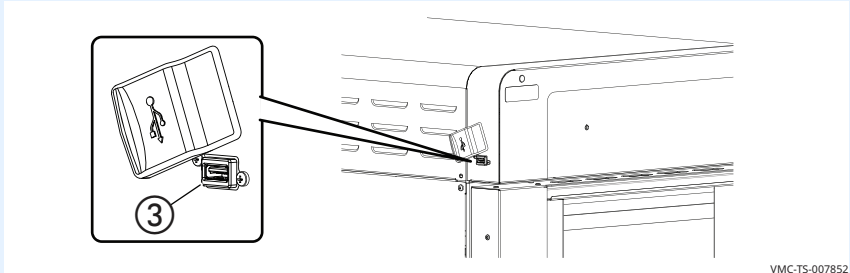
Step	Action
1.	<p>Touch the menu icon ①. The menu screen displays.</p>  <p style="text-align: right; font-size: small;">CT-TS-014846</p>
2.	<p>Touch the "Settings" icon ②. The "General Settings" screen displays.</p>  <p style="text-align: right; font-size: small;">CT-TS-014849</p>
3.	<p>Plug the USB drive ③ into the port.</p>  <p style="text-align: right; font-size: small;">VMC-TS-007852</p>

Continued on next page

Continued from previous page

4. **Scroll** to “System Backup & Update.”
Touch the “Upload Recipes from USB” ④ setting.



Loading the recipes

The oven loads the recipe file. When the process is complete, the “Recipes uploaded” screen displays. **Touch** the check mark to return to the settings screen. **Remove** the USB drive.

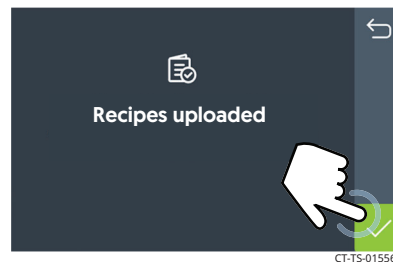

Result

The recipes are now loaded.

How to Save Recipes to a USB Drive

Before you begin

Make sure:

- The oven is on, but not in a cooking mode.
- You will need a USB drive.

Procedure

To download recipes from the oven to a USB drive, do the following.

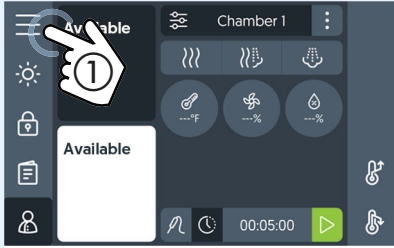
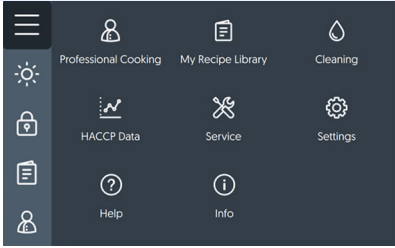
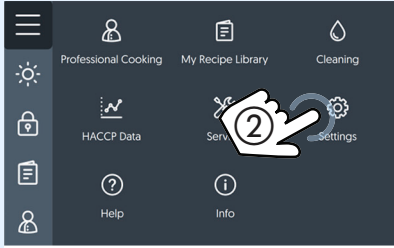
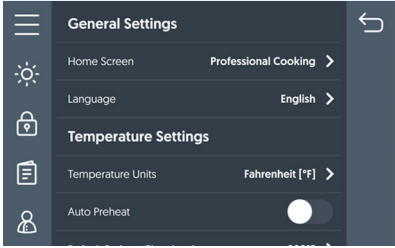
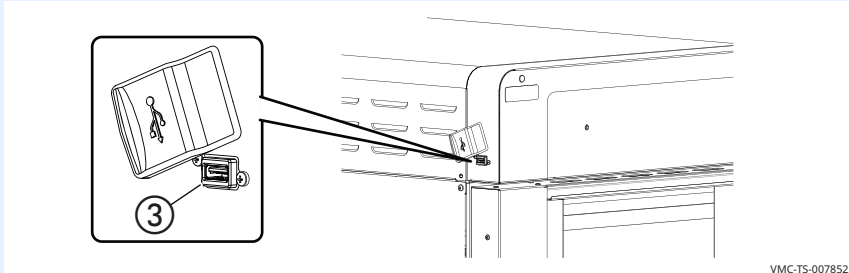
Step	Action
1.	<p>Touch the menu icon ①. The menu screen displays.</p>   <p style="text-align: right;"><small>CT-TS-014846</small></p>
2.	<p>Touch the “Settings” icon ②. The “General Settings” screen displays.</p>   <p style="text-align: right;"><small>CT-TS-014849</small></p>
3.	<p>Plug the USB drive ③ into the port.</p>  <p style="text-align: right;"><small>VMC-TS-007852</small></p>

Continued on next page

Continued from previous page

4. **Scroll** to “System Backup & Update.”

Touch the “Download Recipes to USB” ④ setting.



Loading the recipes

The oven downloads the recipes onto the USB drive. When the process is complete, the “Downloaded successful” screen displays. **Touch** the check mark to return to the settings screen. **Remove** the USB drive.

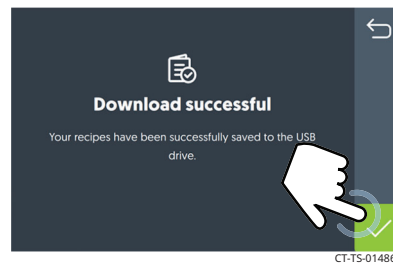

Result

The recipes are now saved to the USB drive.

How to Update Software with a USB Drive

Before you begin

Make sure:

- The oven is on, but not in a cooking mode.
- You will need a USB drive with the updated software. To download the most up to date oven software and register for email notifications when new software versions are released, please visit <https://www.alto-shaam.com/en/customer-support/software-downloads>.
- Do not remove the USB drive during the update process.

Procedure

To update the software, do the following.

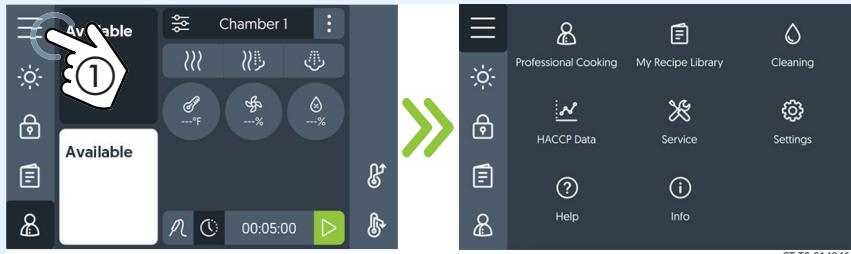
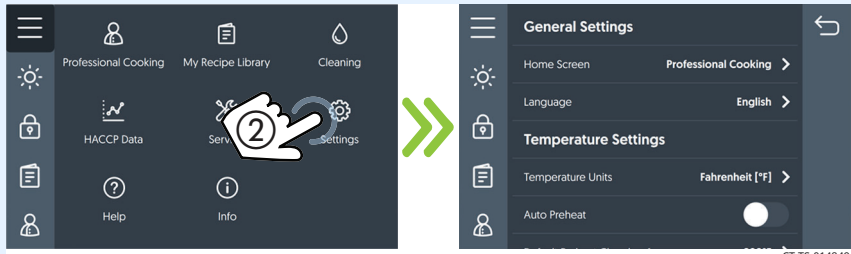
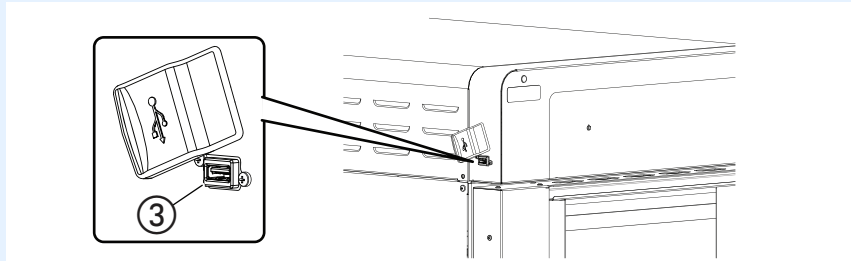
Step	Action
1.	<p>Touch the menu icon ①. The menu screen displays.</p>  <p style="text-align: right;"><small>CT-TS-014846</small></p>
2.	<p>Touch the "Settings" icon ②. The "General Settings" screen displays.</p>  <p style="text-align: right;"><small>CT-TS-014849</small></p>
3.	<p>Plug the USB drive ③ into the port.</p>  <p style="text-align: right;"><small>VMC-TS-007852</small></p>

Continued on next page

Continued from previous page

4. **Scroll** to “System Backup & Update.”

Touch the “Update System Software” ④ setting.

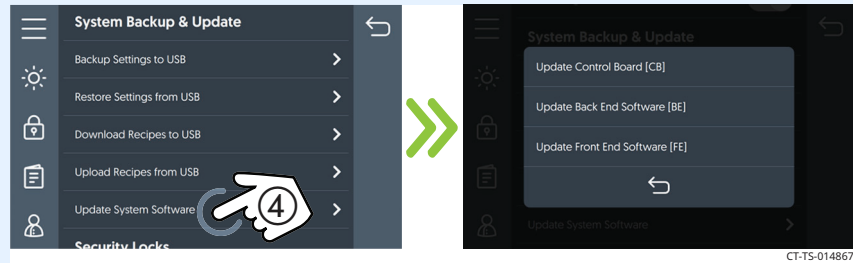

NOTICE Do not remove the USB drive during the update process.

Touch “Update Back End Software (BE)” to update the supporting software between the control board (CB) and interface board (IB). The oven loads the selected software.

Touch “Update Front End Software (FE)” to update the user interface software. The oven loads the selected software.

Touch “Update Control Board (CB)” to update the control board. The oven loads the selected software. The oven verifies the file and then updates the CB.

5. **Touch** the check mark when the update is complete to restart the oven.

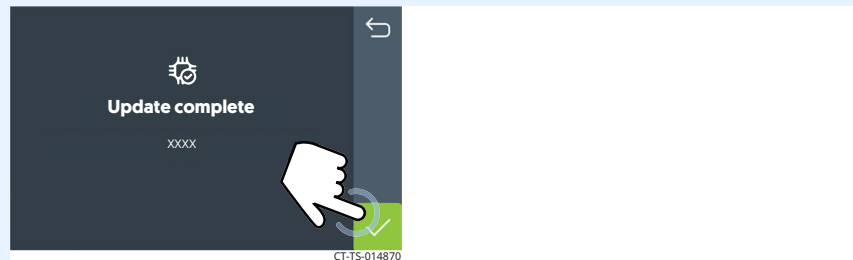

6. **Remove** the USB drive.

Result

The software has now been updated.

How to Change the Home Screen

Procedure

To change the home screen, do the following.

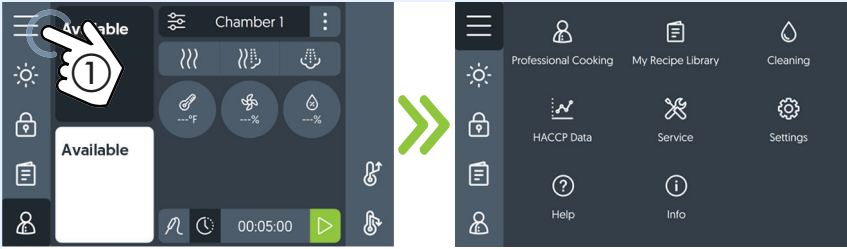
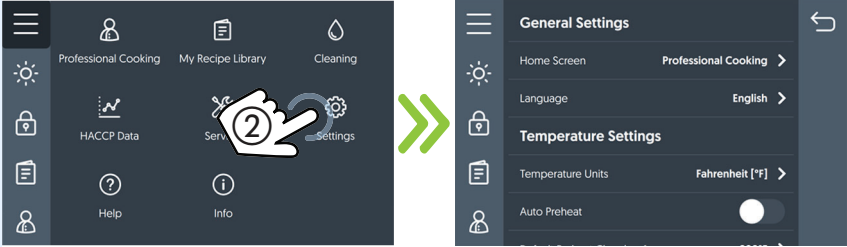
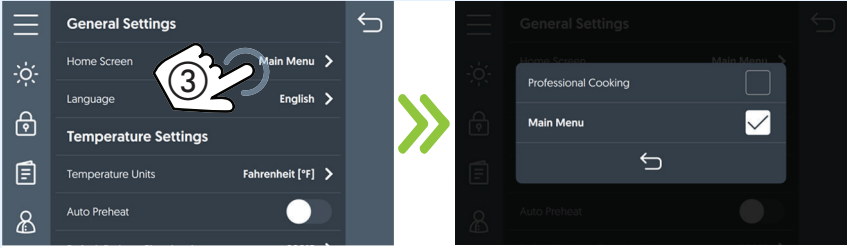
Step	Action
1.	<p>Touch the menu icon ①. The menu screen displays.</p>  <p style="text-align: right; font-size: small;">CT-TS-014846</p>
2.	<p>Touch the “Settings” icon ②. The “General Settings” screen displays.</p>  <p style="text-align: right; font-size: small;">CT-TS-014849</p>
3.	<p>Touch the “Home Screen” setting ③. The select home screen displays.</p>  <p style="text-align: right; font-size: small;">CT-TS-014873</p>

Continued on next page

Continued from previous page

4. **Select** your desired home screen from the list.
Touch the check mark ④ to save the home screen setting.

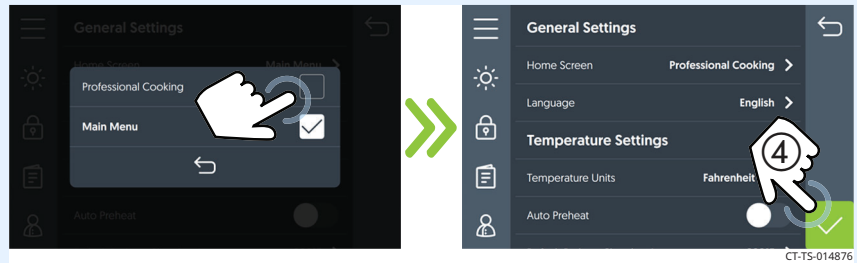

5. **Restart** the oven to reboot the home screen.

Result

The home screen has now been changed.

How to Change the Temperature Scale

Procedure

To change the temperature scale from °F to °C and vice versa, do the following.

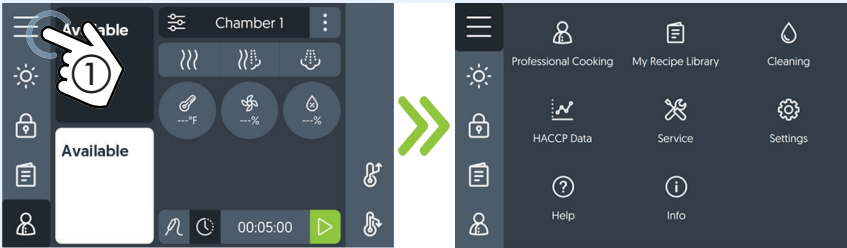
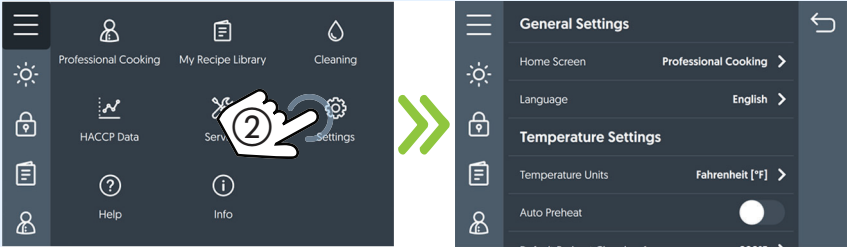
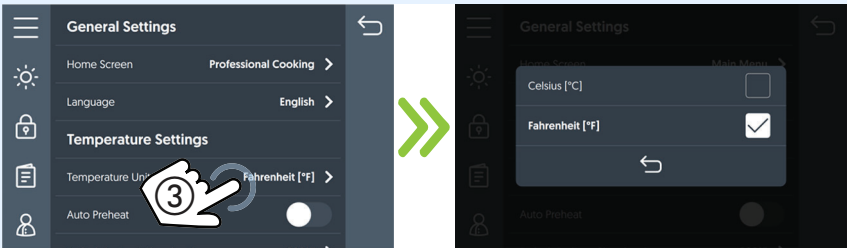
Step	Action
1.	<p>Touch the menu icon ①. The menu screen displays.</p>  <p style="text-align: right; font-size: small;">CT-TS-014846</p>
2.	<p>Touch the “Settings” icon ②. The “General Settings” screen displays.</p>  <p style="text-align: right; font-size: small;">CT-TS-014849</p>
3.	<p>Touch the “Temperature Units” setting ③. The select temperature units screen displays.</p>  <p style="text-align: right; font-size: small;">CT-TS-014879</p>

Continued on next page

Continued from previous page

4. **Select** your desired temperature scale.

Touch the check mark ④ to save the temperature scale setting.

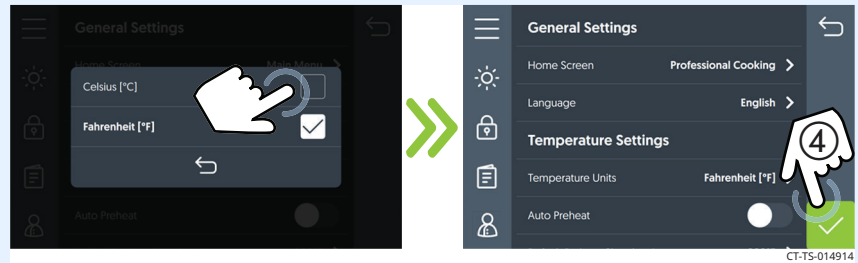

Result

The temperature scale has now been changed.

How to Enable the Handle Light

Procedure

To enable the handle light, do the following.

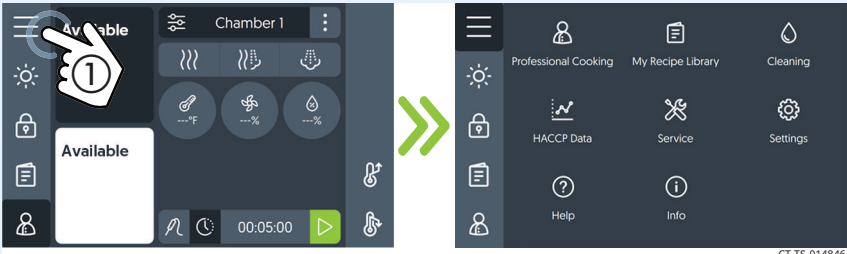
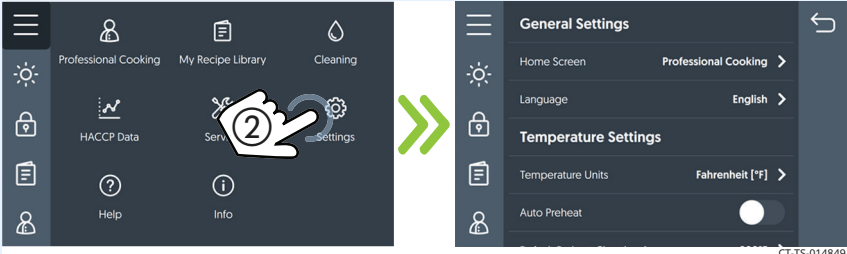
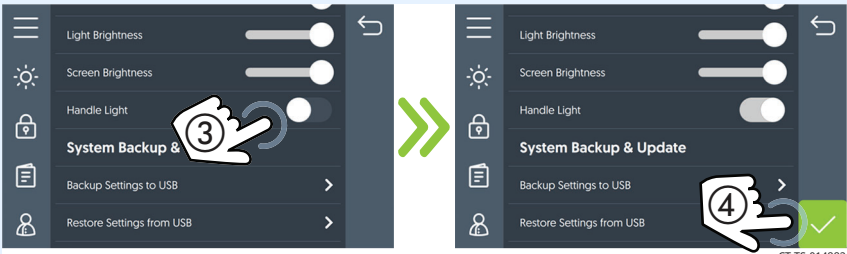
Step	Action
1.	<p>Touch the menu icon ①. The menu screen displays.</p>  <p style="text-align: right; font-size: small;">CT-TS-014846</p>
2.	<p>Touch the "Settings" icon ②. The "General Settings" screen displays.</p>  <p style="text-align: right; font-size: small;">CT-TS-014849</p>
3.	<p>Scroll to the "Handle Light" setting.</p> <p>Touch the Handle Light button ③. Touch the check mark ④. The handle light is now enabled.</p> <p>Repeat the process to disable the handle light.</p>  <p style="text-align: right; font-size: small;">CT-TS-014882</p>

Result

The handle light is now enabled.

How to Enable/Disable Automatic Preheat

Background

Enabling the automatic preheat function preheats the oven upon start up to the preheat temperature. Make sure to set your preheat temperatures. See topic *How to Preheat the Oven*.

Procedure

To enable/disable automatic preheat, do the following.

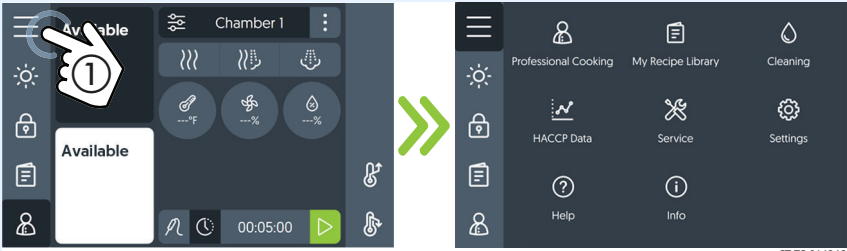
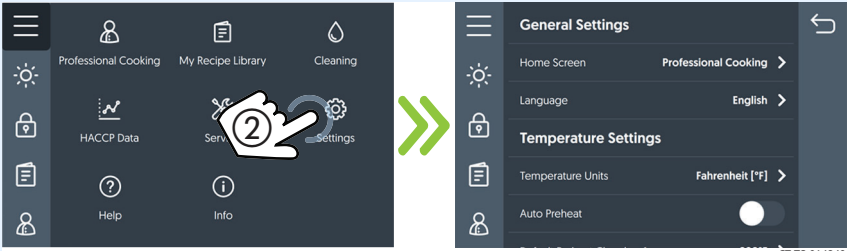
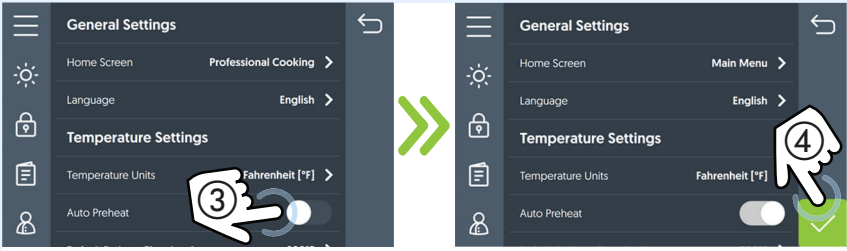
Step	Action
1.	<p>Touch the menu icon ①. The menu screen displays.</p>  <p>CT-TS-014846</p>
2.	<p>Touch the “Settings” icon ②. The “General Settings” screen displays.</p>  <p>CT-TS-014849</p>
3.	<p>Touch the “Auto Preheat” button ③. Touch the check mark ④. The automatic preheat function is now enabled.</p> <p>Repeat the process to disable the automatic preheat function.</p>  <p>CT-TS-014885</p>



Result

The automatic preheat function is now enabled/disabled.

How to Lock Recipe Editing or the Settings Screen

Procedure

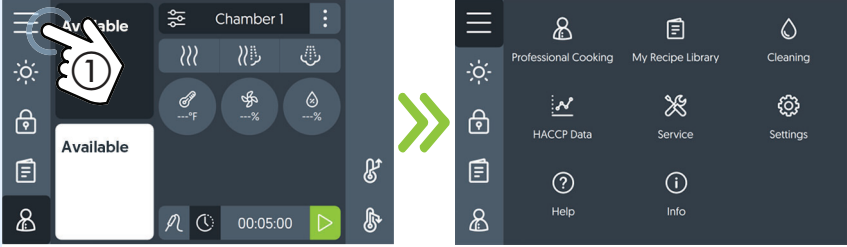
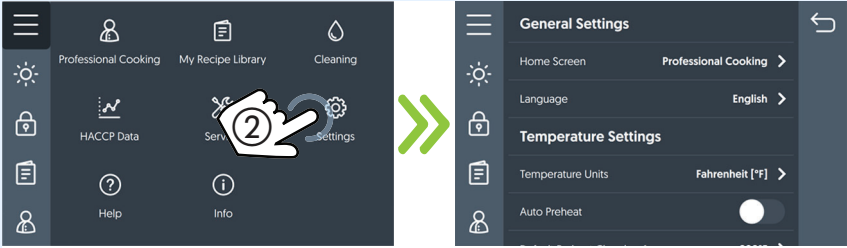
To lock recipe editing or the settings screen, do the following.

Step	Action
1.	<p>Touch the menu icon ①. The menu screen displays.</p>  <p style="text-align: right; font-size: small;">CT-TS-014846</p>
2.	<p>Touch the "Settings" icon ②. The "General Settings" screen displays.</p>  <p style="text-align: right; font-size: small;">CT-TS-014849</p>
3.	<p>Scroll to the "Security Locks."</p> <p>Touch the "Lock Recipe Editing button" ③. The enter pass code screen displays.</p>  <p style="text-align: right; font-size: small;">CT-TS-014887</p>

Continued on next page

Continued from previous page

4. **Create** a pass code ④. **Touch** the check mark ⑤.
Touch the check mark ⑥ to lock recipe editing.

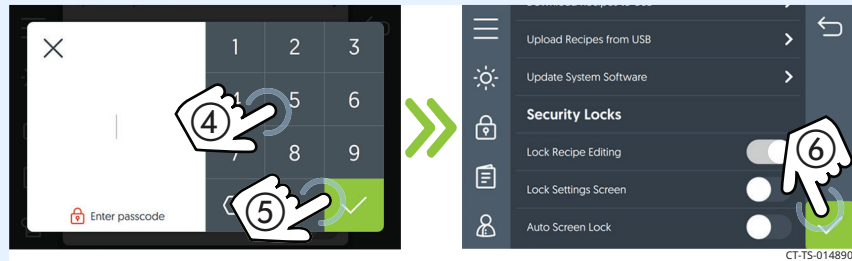

5. **Repeat** the process to lock manual cooking or lock the settings screen.

Result

The lock recipe editing or the settings screen are now locked.

How to View Oven Information

Background

The oven information screen shows the system info, serial number, network status, and connection settings.

Procedure

To view oven information, do the following.

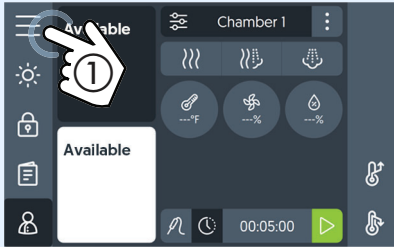
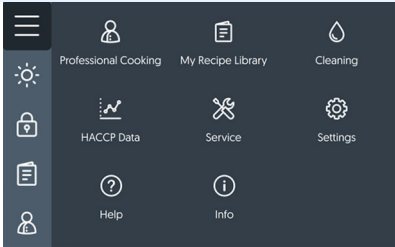
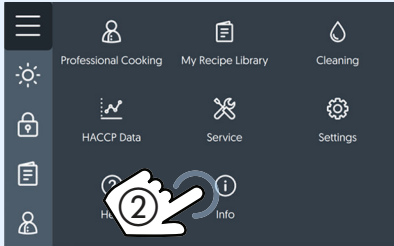
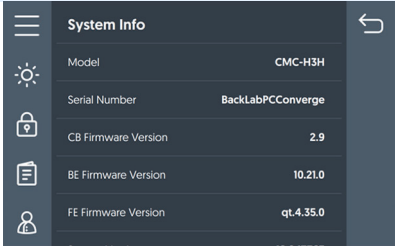
Step	Action
1.	<p>Touch the menu icon ①. The menu screen displays.</p>   <p style="text-align: right; font-size: small;">CT-TS-014846</p>
2.	<p>Touch the "Info" page icon ②. The "System Info" screen displays.</p> <p>Scroll to view the oven model, serial number, system software, network status, and cleaning timer.</p>   <p style="text-align: right; font-size: small;">CT-TS-013894</p>

Result

The oven's information has been viewed.

How to Download HACCP Data

Before you begin

Make sure:



- The oven is on, but not in a cooking mode.
- You will need a USB drive.

Background

HACCP data provides automated record keeping, set-point validation, recipes used, dates and times. The data is stored until the information is downloaded. Once downloaded, the information is removed from the oven's memory. Best practice would be to download the information every 30 days to a USB drive. The file format is plain text file (.csv). The file can be viewed in Microsoft® Excel.

Procedure

To download HACCP data, do the following.

Step	Action
1.	<p>Touch the menu icon ①. The menu screen displays.</p>  <p style="text-align: right; font-size: small;">CT-TS-014846</p>
2.	<p>Touch the "HACCP Data" icon ②. The "HACCP Data" screen displays.</p>  <p style="text-align: right; font-size: small;">CT-TS-014896</p>

Continued on next page

Continued from previous page

3. **Plug** the USB drive ③ into the port.

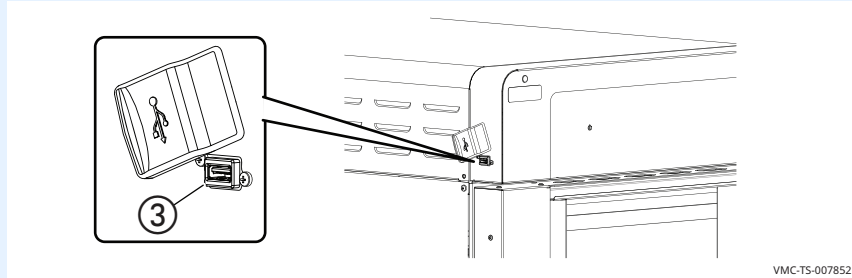

VMC-TS-007852

4. **Touch** the download icon ④.



CT-TS-014899

Loading the data

The oven downloads the data onto the USB drive. When the process is complete, the download successful screen displays. **Touch** the check mark to return to the menu screen. **Remove** the USB drive.

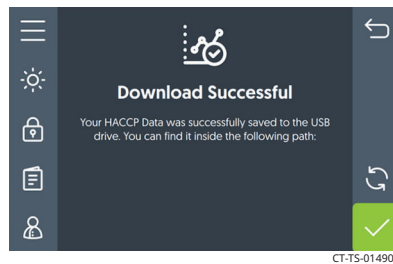

CT-TS-014902

Result

The HACCP data has now been downloaded.

How to Calibrate the Temperature Probe



Before you begin

Make sure:

- The oven is on, but not in cooking mode.
- You have a thermometer.
- You have a container filled with ice and water.

Procedure

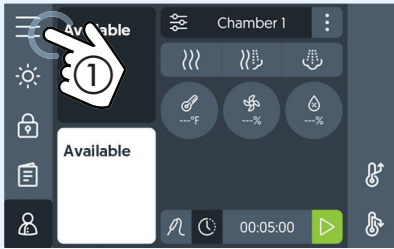
To calibrate the probe, do the following.

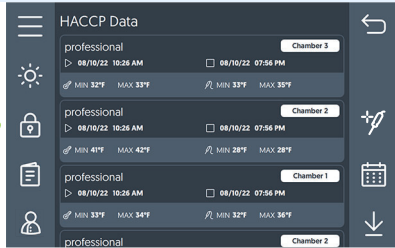
Step	Action
1.	Insert the probe and the thermometer in a container of ice water and allow the temperature to settle to 32°F (0°C).
2.	Touch the menu icon ①. The menu screen displays.
	 
3.	Touch the "HACCP Data" icon ②. The "HACCP Data" screen displays.
	 

Continued on next page

Continued from previous page

4. **Touch** the calibrate probes icon ③.

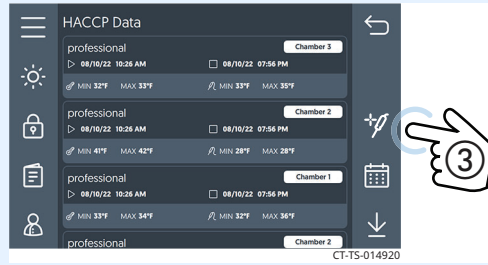

5. **Compare** the probe temperature reading against 32°F (0°C).
Touch the “+” or “-” symbols ④ until the temperature displayed is 32°F (0°C).

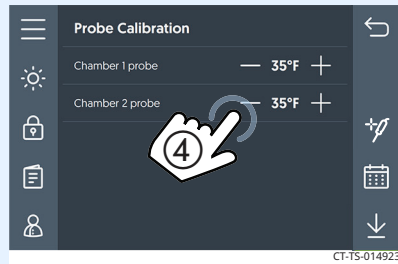

6. **Remove** the probe from the ice water.
7. If the oven has multiple probes, repeat this procedure until all probes are calibrated.

Result

The probe is now calibrated.

Maintenance Schedule

Requirements

- See topic *How to Clean the Oven*.
- Make sure the oven is cooled down and off—inside of chamber 140°F (60°C) or less.

Daily

For daily maintenance, do the following.

- **Remove** any spills with disposable paper wipes or a damp cloth.
- **Wipe** the outside of the oven with a damp cloth.
- **Wipe** the oven gaskets with soap and water.
- **Inspect** the oven gaskets for damage.
- **Wipe** the front door glass.
- **Check** the screen for cracking or peeling. Contact Technical Service if needed.

Weekly

For weekly maintenance, do the following.

- **Clean** the entire oven. **Make sure** to use a non-abrasive nylon scrub pad.
- Do not spray the cleaner directly into the fan openings located in the rear of the oven.

Monthly

For monthly maintenance, do the following.

- **Inspect** and clean the air filters.
- **Clean** out the drip tray line.
- **Check** the supplied water filtration and change as needed.
- **Check** for software updates.
- **Check** lighting.
- **De-scale** as needed.

Yearly

For yearly maintenance, do the following.



NOTE: Must be performed by a qualified professional.

- **Inspect** and test the humidity control.
- **Inspect** and test the catalytic converter element.
- **Inspect** the catalytic converter.
- **Inspect** the air intake. **Check** the length of the tubing for debris clean out or replace as needed.

Continued on next page

Continued from previous page

- **Inspect** all drain hoses and clamps.
 - **Inspect** all steam water injection lines and clamps for leaks or potential issues.
 - **Inspect** wiring to heating elements. Re-tighten or secure as needed. Record the amp draw.
 - **Inspect** wiring to the steam element. Re-tighten or secure as needed. Record the amp draw.
 - **Inspect** the cleaning system pump and hoses for leaks and proper operation.
 - For ovens shipped to New Zealand or Australia, **inspect** the back flow preventer check valve per AS/NZ3500.1 and AS/NZ3500.2
-

- **Check** operation of all electrical cooling fans.
 - **Check** all electrical connections are properly connected and secure to the boards.
 - **Check** door hinges and handles. Tighten, secure, or adjust as needed.
 - **Check** door gaskets for damage and seal.
-

- **Test** steam injection solenoid.
- **Test** condensate solenoid.
- **Run** each chamber in convection mode and test operation.
- **Run** each chamber in steam mode and test operation.

How to Clean the Oven

Precautions



WARNING: Burn hazard.

Wear protective gloves, protective clothing, eye protection, and face protection when handling oven cleaner. Do not open the oven door during the cleaning cycle.

NOTICE

Using improper cleaning procedures will damage the catalyst and void the warranty.

Use only Alto-Shaam cleaner CE-48578 and oven decarbonizer + degreaser spray CE-48623 when running a cleaning cycle identified with a blue icon. The use of any other cleaning chemical may damage the catalyst and void the warranty.

Do not use steel pads, wire brushes, or scrapers when cleaning.

Background

The oven has six different cleaning modes — five for cleaning the oven, identified with blue icons, and one for cleaning the catalyst, identified with the green icon.

- The rinse cycle is a mid-day rinse to reduce the grease and requires no packets.
- The spray clean cycle is for daily use when cooking heavy proteins and requires no packets.
- The light clean cycle is for light debris and requires one packet.
- The medium clean is for heavy debris (10 full loads of chicken) in one chamber and requires three packets.
- The heavy clean is for heavy debris (10 full loads of chicken) in all chambers and requires six packets.
- The descale catalyst cleaning keeps the oven properly maintained. A reminder screen displays after 18 hours of cumulative cleaning (example: after four heavy cleaning cycles). See topic: “How to Descale the Catalyst” to descale the catalyst.





Continued on next page

Continued from previous page

Cleaning the oven

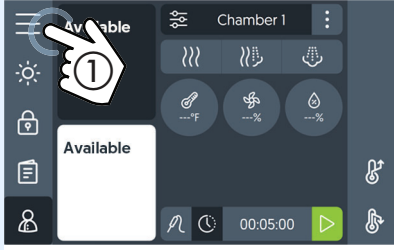
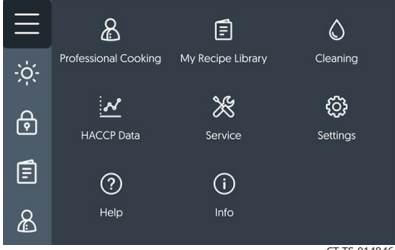
To clean the oven, do the following.

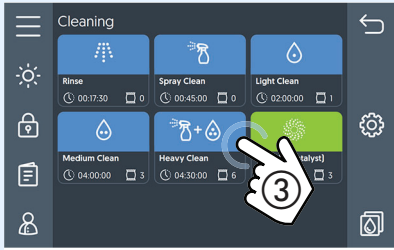
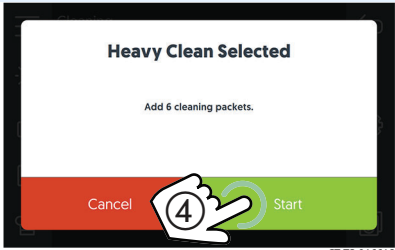
Step	Action
1.	<p>Touch the menu icon ①. The menu screen displays.</p>   <p style="text-align: right; font-size: small;">CT-TS-014846</p>
2.	<p>Touch the "Cleaning" icon ②. The "Cleaning" screen displays.</p>   <p style="text-align: right; font-size: small;">CT-TS-014977</p>
3.	<p>Select either "Spray Clean" or "Heavy Clean" ③.</p> <p>For "Rinse", "Light Clean" or "Medium Clean" go to step 4.</p> <p>Shake the oven decarbonizer + degreaser bottle gently four times before using. Apply 10-12 pumps per chamber, then touch "Continue".</p> <p>Distribute the contents of the packets onto the jet plates equally between the chambers.</p> <p>Touch the start icon ④.</p>   <p style="text-align: right; font-size: small;">CT-TS-016618</p> <p>NOTE: Both programs start with a built-in 30-minute rest for the oven decarbonizer + degreaser to loosen carbon/grease build up. The cleaning cycle then runs.</p> <p>Proceed to step 5.</p>

Continued on next page

Continued from previous page

Non-spray cleaning

4. **Select** "Rinse", "Light Clean" ⑤ or "Medium Clean".

Distribute the contents of the packets onto the jet plates equally between the chambers.

Touch the start icon ⑥.



The oven heats to the required temperature for the cleaning cycle, then the cleaning cycle starts.

NOTE: Touching the cancel icon "X" cancels the cleaning cycle. The oven will start a forced rinse. The forced rinse must complete before operating the oven.

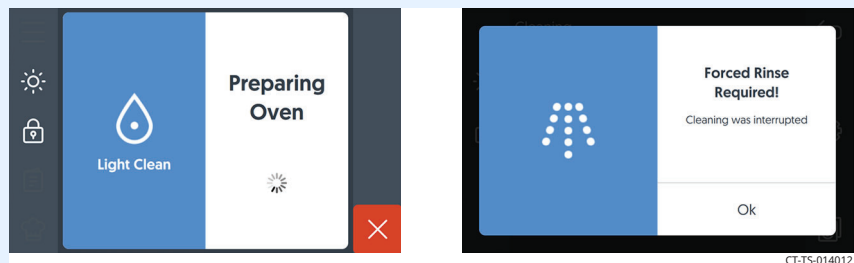

5. **Touch** "Ok" ⑦ when the cleaning cycle is complete.

Repeat the cleaning process as needed.

WARNING: Burn hazard.
Open the door carefully when the cleaning cycle is complete. Escaping hot vapors or steam can cause injury.

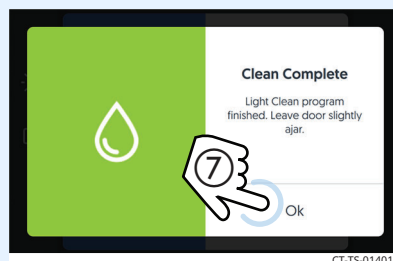

Continued on next page

Continued from previous page

6. **Clean** the door glass with Windex® or equivalent glass cleaner.
7. **Clean** the door gasket with soap and water.
8. **Clean** out any debris from behind the divider gaskets ⑧.

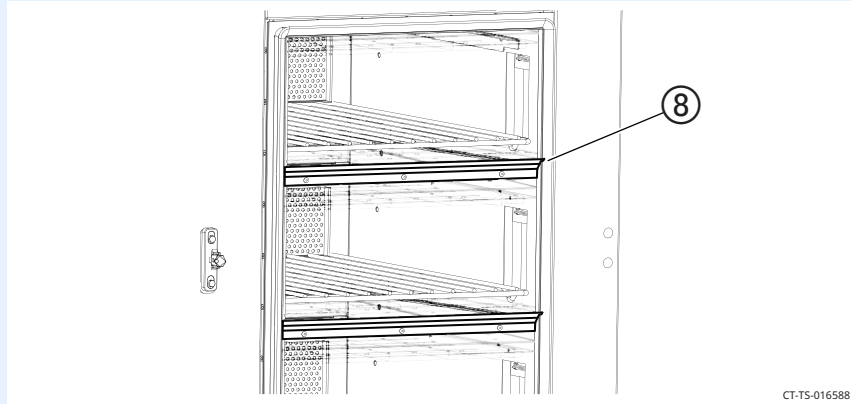

9. **Spray** the exterior of the oven with stainless steel polish. **Wipe** the exterior of the oven with a non-abrasive scrub pad. Follow safety instructions on the bottle of the stainless steel polish.

NOTICE

Use only non-caustic cleaners.

Do not spray directly into the fan openings on the rear of the oven.

Do not use cleaners that contain sodium hydroxide (lye) or phosphorus.

10. **Leave** the door slightly ajar if the cleaning has been done at the end of the day.

Result

The oven is now clean.

How to Descale the Catalyst

Precautions



WARNING: Burn hazard.

Wear protective gloves, protective clothing, eye protection, and face protection when handling oven cleaner. Do not open the oven door during the cleaning cycle.

NOTICE

Using improper cleaning procedures will damage the catalyst and void the warranty.

For a descale catalyst cleaning cycle, use only catalyst descaler CE-47859. The use of any other cleaning chemical may damage the catalyst and void the warranty.

Do not use steel pads, wire brushes, or scrapers when cleaning.

Background

- The descale catalyst cleaning keeps the oven properly maintained.
- The descale catalyst cleaning cycle is identified with a green icon.
- The descale catalyst cleaning cycle requires three descaler packets.
- The descale catalyst cleaning does not need to be run after an oven cleaning mode.
- A descale catalyst cleaning reminder screen displays after 18 hours of cumulative cleaning (example: after four heavy cleaning cycles).

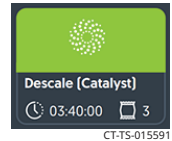

Descal the catalyst

To descale the catalyst, do the following.

Step	Action
1.	<p>Touch the menu icon ①. The menu screen displays.</p>

Continued on next page

Continued from previous page

2. **Touch** the “Cleaning” icon ②. The “Cleaning” screen displays.

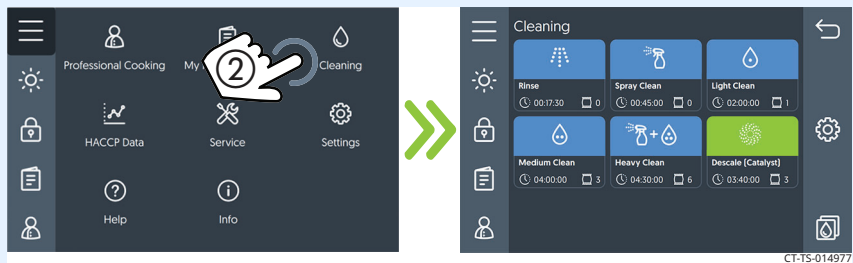

3. **Touch** the “Descal (Catalyst)” icon ③.

Distribute the contents of the descaler packets onto the jet plates equally between the chambers.

Touch “Start” ④ to start the descale catalyst cleaning cycle.

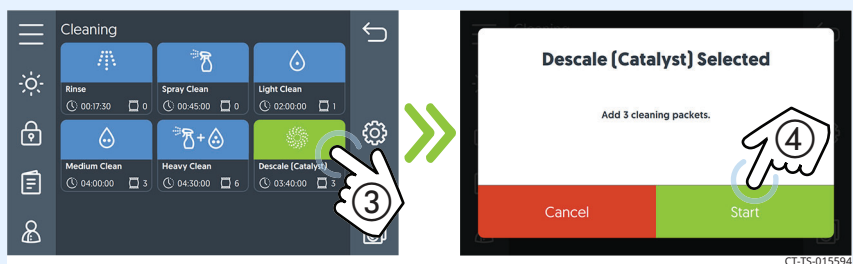

The oven heats to the required temperature for the descale catalyst cleaning cycle, then the cycle starts.

NOTE: Touching the cancel icon “X” cancels the descale catalyst cleaning cycle. The oven will start a forced rinse. The forced rinse must complete before operating the oven.

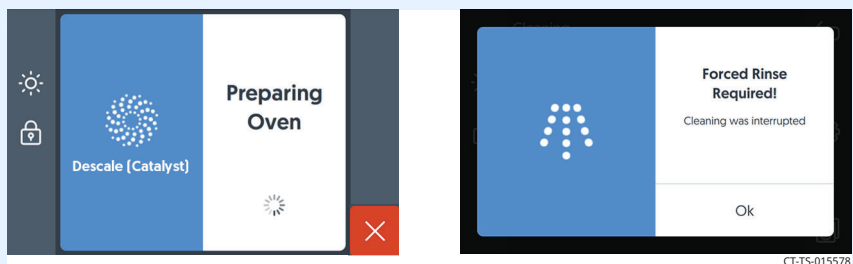

Continued on next page

Continued from previous page

4. **Touch "Ok" ⑤** when the descale catalyst cleaning cycle is complete.



WARNING: Burn hazard.
Open the door carefully when the descale catalyst cleaning cycle is complete. Escaping hot vapors or steam can cause injury.

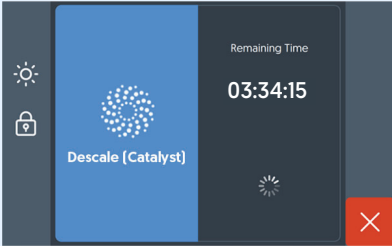

➤➤

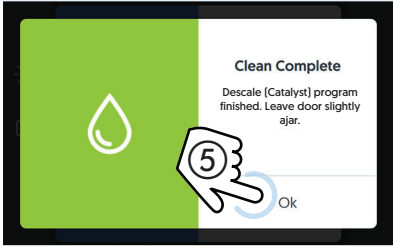

CT-TS-015597

Result

The catalyst has now been descaled.



How to View the Cleaning Log

Background

The cleaning log allows the user to view details about the previously completed cleaning cycles on the unit.

Procedure

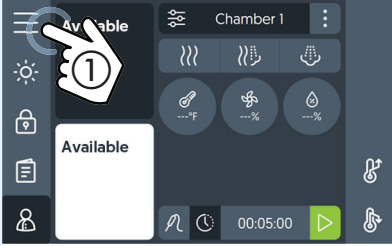
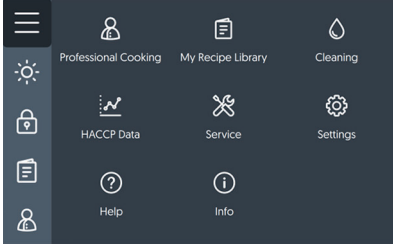
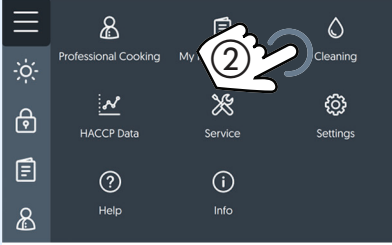
To view the cleaning log, do the following.

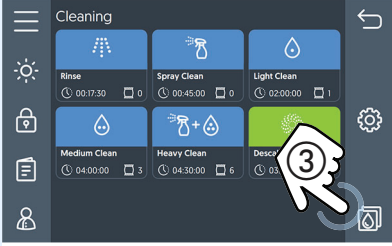
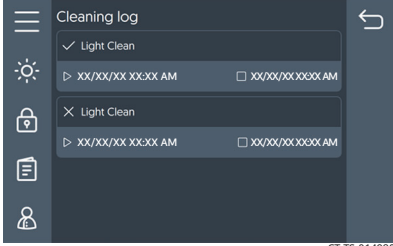
Step	Action
1.	<p>Touch the menu icon ①. The menu screen displays.</p>   <p style="text-align: right;"><small>CT-TS-014846</small></p>
2.	<p>Touch the “Cleaning” icon ②. The “Cleaning” screen displays.</p>   <p style="text-align: right;"><small>CT-TS-014977</small></p>
3.	<p>Touch the cleaning log icon ③. The “Cleaning log” screen displays.</p>   <p style="text-align: right;"><small>CT-TS-014980</small></p>

Result

The cleaning log has been viewed.

How to Set the Cleaning Time

Background

The user can set a cleaning frequency to schedule when the unit will go through a cleaning cycle.

Procedure

To set the cleaning time, do the following.

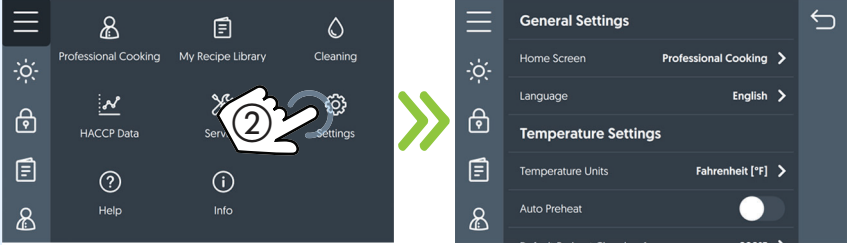
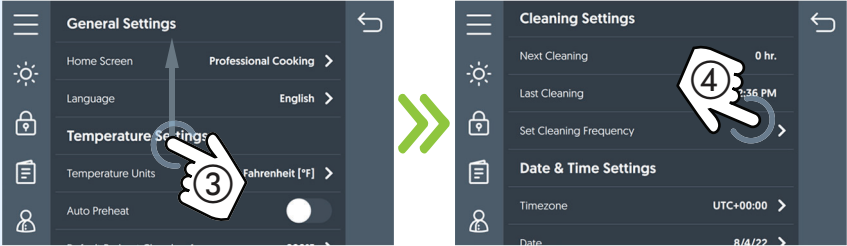
Step	Action
1.	<p>Touch the menu icon ①. The menu screen displays.</p>  <p>CT-TS-014846</p>
2.	<p>Touch the “Settings” icon ②. The “General Settings” screen displays.</p>  <p>CT-TS-014849</p>
3.	<p>Scroll ③ until “Cleaning Settings” displays. Touch the “Set Cleaning Frequency” ④ setting.</p>  <p>CT-TS-014983</p>

Continued on next page

Continued from previous page

4. **Touch** the “Hours” setting ⑤ to set the hours. **Enter** the desired time using the key pad. **Touch** the check mark.

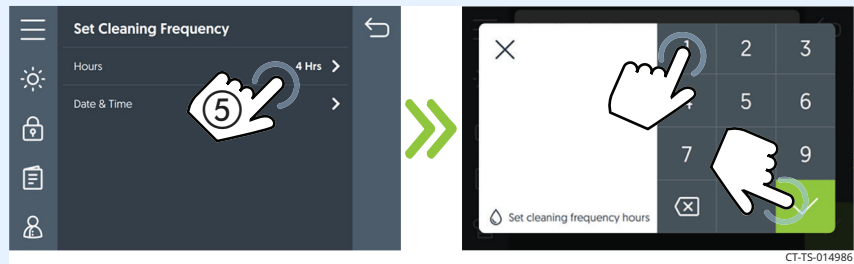

CT-TS-014986

5. **Touch** the “Date & Time” setting ⑥ to set the day and time. **Touch** the check box ⑦ next to a day to set it. **Touch** the check mark.

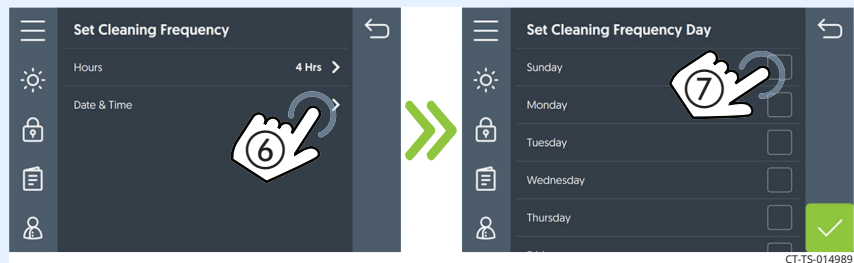

CT-TS-014989

6. The “Set cleaning frequency hours” screen will display.
Touch the “AM”/“PM” button ⑧ to choose whether the cleaning time is set for AM or PM.
Enter the time of day for the cleaning. **Touch** the check mark.
Touch the check mark on the “Set Cleaning Frequency” setting screen.

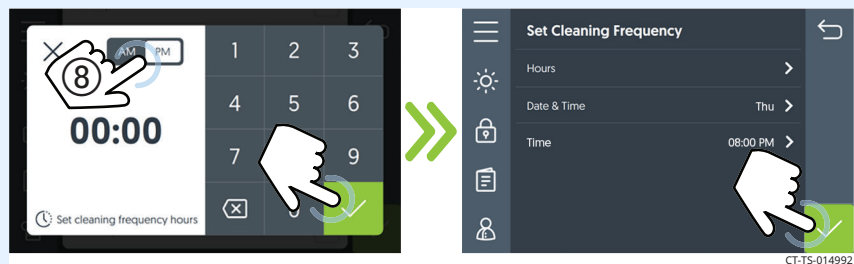

CT-TS-014992

Result

The cleaning frequency has been set.

Error Codes

Code	Description	Parameters that trigger the error	Possible Cause(s)
E-3	Motor error	No chamber motor rotation detected for greater than 30 seconds.	<ol style="list-style-type: none"> 1. Power down the control using the ON/OFF button. 2. Cycle power to the oven either by unplugging the oven or setting the main disconnect switch OFF and ON. 3. Continue operation of the oven. If the error reoccurs, contact Technical Service.
E-10	Sensor short	Control board detects that the chamber sensor is shorted.	<ol style="list-style-type: none"> 1. Power down the control using the ON/OFF button. 2. Cycle power to the oven either by unplugging the oven or setting the main disconnect switch OFF and ON. 3. Continue operation of the oven. If the error reoccurs, contact Technical Service.
E-10	Sensor short	Control board detects that the probe in the chamber is shorted.	<ol style="list-style-type: none"> 1. Investigate the food probe for damage. Replace if damaged. 2. Power down the control using the ON/OFF button. 3. Cycle power to the oven either by unplugging the oven or setting the main disconnect switch OFF and ON. 4. Continue operation of the oven. If the error reoccurs, contact Technical Service.
E-11	Sensor open	Cavity air sensor reading > 650°F (343°C).	<ol style="list-style-type: none"> 1. Power down the control using the ON/OFF button. 2. Cycle power to the oven either by unplugging the oven or setting the main disconnect switch OFF and ON. 3. Continue operation of the oven. If the error reoccurs, contact Technical Service.
E-30	Unit under temperature	Cavity temperature remains 25°F (14°C) below target for more than 90 minutes.	<ol style="list-style-type: none"> 1. Was the oven preheated before loading the food? 2. Was the oven loaded with frozen food? 3. Press the high limit reset buttons. 4. Power down the control using the ON/OFF button. Turn the oven back ON and start a cook.
E-31	Electronics over temperature	Control board temperature exceeds 158°F (70°C).	<ol style="list-style-type: none"> 1. Make sure the cooling fan(s) are operating. 2. Make sure the exhaust vents are clean and free of debris. 3. Make sure the oven clearances are met. 4. Ambient temperature greater than 105°F (41°C). 5. Check the door gasket for damage and proper seal.

Code	Description	Parameters that trigger the error	Possible Cause(s)
E-31	Electronics over temperature	Interface board temperature exceeds 184°F (84°C).	<ol style="list-style-type: none"> 1. Power down the control using the ON/OFF button. 2. Cycle power to the oven either by unplugging the oven or setting the main disconnect switch OFF and ON. 3. Continue operation of the oven. If the error reoccurs, contact Technical Service.
E-31	Electronics over temperature	Chamber temperature sensor > 600°F (316°C) for Combi or Convection or chamber temperature sensor > 395°F (202°C) for Steam or Cleaning.	<ol style="list-style-type: none"> 1. If the oven has experienced an over temperature condition, allow the oven to cool down for a minimum of 30 minutes. 2. Press the high limit reset buttons. 3. Continue operation of the oven. If the error reoccurs, contact Technical Service.
E-31	Electronics over temperature	B3 sensor is higher than 212°F (100°C) for more than 180 seconds.	<ol style="list-style-type: none"> 1. Make sure the water supply line(s) is connected to the oven and that the shut off valve for the water connections is in the open position. 2. If connected to water filter(s), make sure the filters are not in need of replacement. 3. Power down the control using the ON/OFF button. 4. Cycle power to the oven either by unplugging the oven or setting the main disconnect switch OFF and ON. 5. Continue operation of the oven. If the error reoccurs, contact Technical Service.
E-50	Control board temperature error	Temperature measurement failure on the control board.	<ol style="list-style-type: none"> 1. Make sure the cooling fan(s) are operating. 2. Make sure the exhaust vents are clean and free of debris. 3. Make sure the oven clearances are met. 4. Ambient temperature greater than 105°F (41°C). 5. Check the door gasket for damage and proper seal.
E-55	Vent not open	60 seconds after the chamber venting motor is activated, the chamber vent valve did not open.	<ol style="list-style-type: none"> 1. Power down the control using the ON/OFF button. 2. Cycle power to the oven either by unplugging the oven or setting the main disconnect switch OFF and ON. 3. Continue operation of the oven. If the error reoccurs, contact Technical Service.
E-78	Voltage monitor output is too low	Incoming line voltage is too low (<190V) or voltage monitor output is shorted.	<ol style="list-style-type: none"> 1. Make sure the oven plug is fully seated in electrical outlet. 2. Reset the main circuit breaker for the oven. If error reoccurs, contact Technical Service.
E-79	Over voltage	Incoming line voltage is too high (>250V) or voltage monitor output is open.	<ol style="list-style-type: none"> 1. Make sure the oven plug is fully seated in electrical outlet. 2. Reset the main circuit breaker for the oven. If error reoccurs, contact Technical Service.

Code	Description	Parameters that trigger the error	Possible Cause(s)
E-94	Interface Board - Control Board communication error	No signal transfer for more than 5 seconds between the interface board and the control board.	<ol style="list-style-type: none"> 1. Make sure the oven plug is fully seated in electrical outlet. 2. Reset the main circuit breaker for the oven. If error reoccurs, contact Technical Service.
E-108	Cooling fan over temperature	Chassis bi-metal temperature sensor over temperature 130°F (54°C).	<ol style="list-style-type: none"> 1. Make sure the cooling fan(s) are operating. 2. Make sure the exhaust vents are clean and free of debris. 3. Make sure the oven clearances are met. 4. Ambient temperature greater than 105°F (41°C). 5. Check the door gasket for damage and proper seal.
E-109	High limit error Note: Contact an authorized Alto-Shaam service partner.	Open circuit detected across high limit switch.	<ol style="list-style-type: none"> 1. If the oven has experienced an over temperature condition, allow the oven to cool down for a minimum of 30 minutes. 2. Press the high limit reset buttons. 3. Continue operation of the oven. If the error reoccurs, contact Technical Service.
E-606	Oven cleaning system failure	Convection fan error, high limit error, cavity temperature sensor open or short, or communication for at least 15 seconds during cleaning.	<ol style="list-style-type: none"> 1. Contact Technical Service. 2. Manually clean the oven. 3. Manually rinse the oven. 4. Make sure to remove cleaners before operating the oven.

What to do if the Fan Indicator Light Illuminates

Procedure

If the fan indicator light ① illuminates, do the following.

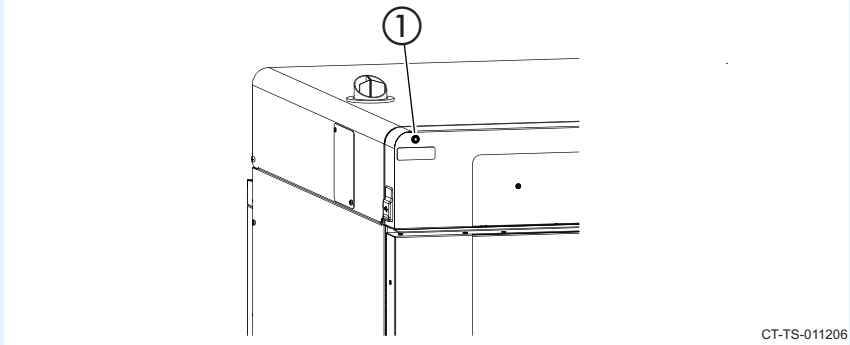
Step	Action
1.	Turn off the oven and allow it to cool.  CT-TS-011206
2.	Resume operation of the oven. NOTE: If the fan indicator light remains on, the appliance is malfunctioning. Disconnect the appliance from the power supply and have it serviced by a qualified technician.

Result

The procedure is now complete.

What to do if the High Limit Screen Displays

Procedure

If the high limit screen displays, do the following.

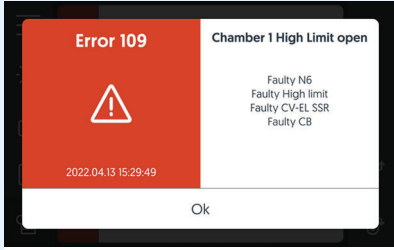
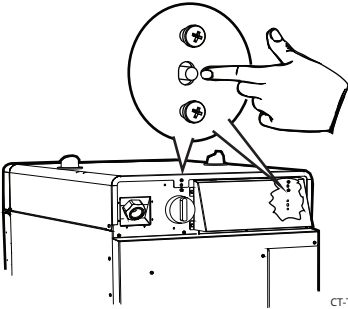
Step	Action
1.	<p>Press and release the high limit temperature reset button(s).</p> <p>NOTE: The high limit temperature reset buttons are located under the fan cover.</p> <div style="display: flex; align-items: center;">   </div> <p style="text-align: right; font-size: small;">CT-TS-013954</p>
2.	<p>Resume operation of the oven.</p> <p>NOTE: If the high limit screen continues to display, the appliance is malfunctioning. Turn off the appliance and have the oven serviced by a qualified technician.</p>

Result

The procedure is now complete.

This page is intentionally left blank.

Warranty

Introduction

Alto-Shaam, Inc. warrants to the original purchaser only, that any original part found to be defective in material or workmanship will be replaced with a new or rebuilt part at Alto-Shaam's option, subject to provisions hereinafter stated.

Warranty Period

The original parts warranty period is as follows:

- For all other original parts, one (1) year from the date of installation of appliance or fifteen (15) months from the shipping date, whichever occurs first.
- The labor warranty period is one (1) year from the date of installation or fifteen (15) months from the shipping date, whichever occurs first.
- Alto-Shaam will bear normal labor charges performed during standard business hours, excluding overtime, holiday rates or any additional fees.
- For the refrigeration compressor, if installed, the warranty period is five (5) years from the date of original installation of the appliance.
- For heating elements on Halo Heat® Cook and Hold ovens, the warranty period is for as long as the original owner owns the oven. This warranty period applies to units sold after 2/1/2009 and excludes holding-only ovens.
- To be valid, a warranty claim must be asserted during the applicable warranty period. This warranty is not transferable.

Exclusions

This warranty does not apply to:

- Calibration.
- Replacement of light bulbs, rubber gaskets, grease filters, air filters, racks, jet plates, and/or the replacement of glass due to damage of any kind.
- Equipment damage caused by accident, shipping, improper installation or alteration.
- Equipment used under conditions of abuse, misuse, carelessness or abnormal conditions, including but not limited to, equipment subjected to harsh or inappropriate chemicals, including but not limited to, compounds containing chloride or quaternary salts, poor water quality, or equipment with missing or altered serial numbers.
- Equipment damage caused by use of any cleaning agents other than those recommended by Alto-Shaam, including but not limited to damage due to chlorine or other harmful chemicals.
- Any losses or damage resulting from malfunction, including loss of food product, revenue, or consequential or incidental damages of any kind.
- Equipment modified in any manner from original model, substitution of parts other than factory authorized parts, unauthorized removal of any parts including legs, or unauthorized addition of any parts.

Continued on next page

WARRANTY

Continued from previous page

- Equipment damage incurred as a direct result of poor water quality*, inadequate maintenance of steam generators and/or surfaces affected by water. Water quality and required maintenance of steam generating equipment is the responsibility of the owner/operator.
 - Equipment damage incurred as a result of not following the required maintenance schedule published in the manuals for the equipment.
-

Conclusion

This warranty is exclusive and is in lieu of all other warranties, express or implied, including the implied warranties of merchantability and fitness for a particular purpose. No person except an officer of Alto-Shaam, Inc. is authorized to modify this warranty or to incur on behalf of Alto-Shaam any other obligation or liability in connection with Alto-Shaam equipment.

**Refer to the product spec sheet for water quality standards.*

DECLARATION OF CONFORMITY

Manufacturer:
Alto-Shaam, Inc.
W164 N9221 Water Street
Menomonee Falls, WI 53202-0450
U.S.A.



EQUIPMENT TYPE:	Household and Similar Electric Appliances
EQUIPMENT DESCRIPTION:	Commercial Electric Convection Ovens
MODEL NUMBER:	VMC-H2, VMC-H3, VMC-H4, VMC-H2H, VMC-H2HW VMC-H3H, VMC-H3HW, VMC-H4H, VMC-F3E, VMC-F4E with or without a V after the dash. CMC-H2H, CMC-H3H with or without option VH
APPLIED DIRECTIVES:	Low Voltage Directive 2014/35/EU MD (Machinery Directive) 2006/42/EC EMC – 2014/30/EC RED – 2014/53/EU
APPLIED STANDARDS:	EN 60335-1:2012+AC:2014 + A11:2014 EN 60335-2-42:2003 + A1:2008 + A11:2012 AS/NZS 60335.1:2011 + A1:2012 + A2:2014 + A3:2015. AS/NZS 60335.1:2020 EN 55014-1: CISPR 14, EN 55014-2: CISPR 14 EN 62479, EN 300 328, EN 301 489, EN 300 893



We the undersigned, hereby declare that the equipment specified above conforms to the above Directives and Standards

Manufacturer Name:
ALTO-SHAAM INC.
NAME: Christa Pieper
TITLE: Certification Manager

SIGNATURE: 
DATE: March 4th 2022



DECLARATION OF CONFORMITY

DECLARATION OF CONFORMITY

Manufacturer:
Alto-Shaam, Inc.
W164 N9221 Water Street
Menomonee Falls, WI 53202-0450



EQUIPMENT TYPE: Household and Similar Electric Appliances

EQUIPMENT DESCRIPTION: Commercial Convection Ovens

MODEL NUMBER: VMC-H2, VMC-H2H, VMC-H2HW, VMC-H3, VMC-H3H, VMC-H3HW, VMC-H4, VMC-H4H, VMC-F3E, VMC-F4E, CMC-H2H, CMC-H3H with or without option VH

APPLIED UK REGULATIONS:

- Supply of Machinery (Safety) Regulations 2008
- Electromagnetic Compatibility Regulations 2016
- The Restriction of the Use of Certain Hazardous Substances in Electrical and Electronic Equipment Regulations 2012
- Radio Equipment Regulations 2017

APPLIED STANDARDS:

EN 60335-1:2012+AC:2014 + A11:2014
EN 60335-2-42:2003 + A1:2008 + A11:2012
EN 55014-1:2018, EN 55014-2:2016



We the undersigned, hereby declare that the equipment specified above conforms to the above Directives and Standards

Manufacturer Name:
ALTO-SHAAM INC.
NAME: Christa Pieper
TITLE: Certification Manager

SIGNATURE: 
DATE: March 4th 2022





ALTO-SHAAM.

Menomonee Falls, WI U.S.A.

Phone 800 -558-8744 | +1-262-251-3800 | alto-shaam.com

ASIA

Shanghai, China
Phone +86-21-6173-0336

AUSTRALIA

Brisbane, Queensland
Phone 800-558-8744

CANADA

Concord, Ontario Canada
Toll Free Phone 866-577-4484
Phone +1-905-660-6781

FRANCE

Aix en Provence, France
Phone +33(0)4-88-78-21-73

GMBH

Bochum, Germany
Phone +49 (0)234 298798-0

ITALY

Padua, Italy
Phone +39 3476073504

INDIA

Pune, India
Phone +91 9657516999

MEXICO

Phone +52 1 477-717-3108

MIDDLE EAST & AFRICA

Dubai, UAE
Phone +971-4-321-9712

CENTRAL & SOUTH AMERICA

Miami, FL USA
Phone +1 954-655-5727