

ALTO-SHAAM®

GAS FRYER
FryTech Series



ASF-60G shown with optional automatic basket lifts



ASF-75G shown with optional automatic basket lifts

**ASF-60G and
ASF-75G
Gas Fryers
with
Basic Control**

- **INSTALLATION**
- **OPERATION**
- **MAINTENANCE**



W164 N9221 Water Street • P.O. Box 450 • Menomonee Falls, Wisconsin 53052-0450 USA
PHONE: 262.251.3800 • 800.558.8744 USA/CANADA FAX: 262.251.7067 • 800.329.8744 U.S.A. ONLY
www.alto-shaam.com

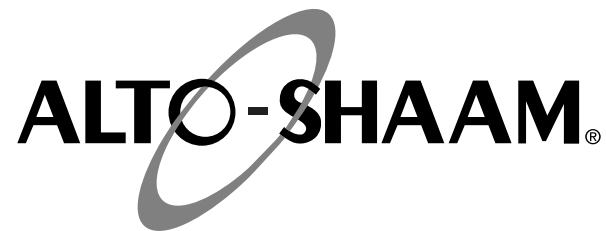

Delivery	1	Service	
Unpacking	1	Service Troubleshooting	31-32
Safety Procedures and Precautions	2	ASF-75G Service Views	34-38
		ASF-60G Service Views	39-42
Installation		Wire Diagrams	
Installation Requirements	5-11	ASF-75G, 120V	43
Dimension Drawings, weights & capacities	3-4	ASF-75G, 230V	44
Clearance Requirements	5	ASF-60G, 120V	45
Site Installation & Leveling	6	ASF-60G, 230V	46
Ventilation	7		
Gas Specifications	8	Warranty	
Gas Connection	9	Transportation Damage and Claims	Back Cover
Restraint Requirements - Mobile Equipment	10	Limited Warranty	Back Cover
Electrical Specifications	11		
Operating Instructions			
Oil/Shortening Requirements	12		
Controls Behind Access Panel	13		
Boil-Out Instructions	14-15		
Start-Up & General Operation	16		
Cleaning & Maintenance	17		
Oil Filtrations (For units with installed option)	18-21		
Suggested Frying Times	22-23		
Basic Control Operation	24-30		

ALTO-SHAAM®

DELIVERY

This Alto-Shaam appliance has been thoroughly tested and inspected to ensure only the highest quality unit is provided. Upon receipt, check for any possible shipping damage and report it at once to the delivering carrier. *See Transportation Damage and Claims section located in this manual.*

This appliance, complete with unattached items and accessories, may have been delivered in one or more packages. Check to ensure that all standard items and options have been received with each model as ordered.

Save all the information and instructions packed with the appliance. Complete and return the warranty card to the factory as soon as possible to ensure prompt service in the event of a warranty parts and labor claim.

This manual must be read and understood by all people using or installing the equipment model. Contact the Alto-Shaam Tech Team Service Department if you have any questions concerning installation, operation, or maintenance.

NOTE: All claims for warranty must include the full model number and serial number of the unit.

UNPACKING

1. Carefully remove the appliance from the carton or crate.

NOTE: Do not discard the carton and other packaging material until you have inspected the unit for hidden damage and tested it for proper operation.

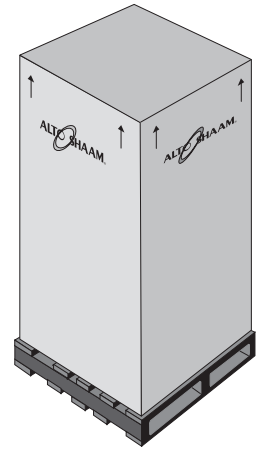

2. Read all instructions in this manual carefully before initiating the installation of this appliance.

DO NOT DISCARD THIS MANUAL.

This manual is considered to be part of the appliance and is to be provided to the owner or manager of the business or to the person responsible for training operators. *Additional manuals are available from the Alto-Shaam Tech Team Service Department.*

3. Remove all protective plastic film, packaging materials, and accessories from the appliance before connecting electrical power. Store any accessories in a convenient place for future use.

DANGER



BEFORE STARTING THE APPLIANCE, MAKE CERTAIN YOU DO NOT DETECT THE ODOR OF GAS.

IF THE ODOR OF GAS IS DETECTED:

- DO NOT attempt to light any appliance.
- DO NOT touch any electrical switches.
- Extinguish any open flame.
- Use a telephone **OUTSIDE THE PROPERTY & IMMEDIATELY** contact your gas supplier.
- If unable to contact your gas supplier, contact the fire department.

WARNING



In the event of loss of power to the appliance, turn the “burner control knobs” to the OFF position. Remove food product from the unit. If burner control fails to extinguish the flame, shut off main gas valve located in rear of unit.

KEEP THIS MANUAL IN A CONVENIENT LOCATION FOR REFERENCE.

INSTALLATION

SAFETY PROCEDURES AND PRECAUTIONS

Knowledge of proper procedures is essential to the safe operation of electrically and/or gas energized equipment. In accordance with generally accepted product safety labeling guidelines for potential hazards, the following signal words and symbols may be used throughout this manual.

DANGER



Used to indicate the presence of a hazard that **WILL** cause severe personal injury, death, or substantial property damage if the warning included with this symbol is ignored.

WARNING



Used to indicate the presence of a hazard that **CAN** cause personal injury, possible death, or major property damage if the warning included with this symbol is ignored.

CAUTION



Used to indicate the presence of a hazard that can or will cause minor or moderate personal injury or property damage if the warning included with this symbol is ignored.

CAUTION

Used to indicate the presence of a hazard that can or will cause minor personal injury, property damage, or a potential unsafe practice if the warning included with this symbol is ignored.

NOTE: Used to notify personnel of installation, operation, or maintenance information that is important but not hazard related.

1. This appliance is intended to cook, hold or process foods for the purpose of human consumption. No other use for this appliance is authorized or recommended.
2. This appliance is intended for use in commercial establishments where all operators are familiar with the purpose, limitations, and associated hazards of this appliance. Operating instructions and warnings must be read and understood by all operators and users.
3. Any troubleshooting guides, component views, and parts lists included in this manual are for general reference only and are intended for use by qualified technical personnel.
4. This manual should be considered a permanent part of this appliance. This manual and all supplied instructions, diagrams, schematics, parts lists, notices, and labels must remain with the appliance if the item is sold or moved to another location.

NOTE



For equipment delivered for use in any location regulated by the following directive:

DO NOT DISPOSE OF ELECTRICAL OR ELECTRONIC EQUIPMENT WITH OTHER MUNICIPAL WASTE.

INSTALLATION

ASF-75G SPECIFICATIONS

<p>DIMENSIONS EXTERIOR (H x W x D)</p> <p>ASF-75G WITHOUT FILTRATION OR LIFTS 44-13/16" x 24-13/16" x 37-7/16" (1138mm x 629mm x 951mm)</p> <p>ASF-75G WITH FILTRATION AND LIFTS 44-13/16" x 24-13/16" x 38-11/16" (1138mm x 629mm x 983mm)</p> <p>BASKET DIMENSIONS (H x W x D) 6" x 9-3/16" x 14-3/16" (152mm x 232mm x 337mm)</p>	<p>STANDARD ACCESSORIES</p> <p><input type="checkbox"/> Basket, Half-Size (2 INCLUDED AS STANDARD) BS-27140</p> <p>Brush Set (ONE 3-BRUSH SET INCLUDED AS STANDARD)</p> <p><input type="checkbox"/> SCRUB BRUSH BH-28693</p> <p><input type="checkbox"/> STRAIGHT BRUSH BH-28691</p> <p>Filter, Paper (7 PAPER FILTERS INCLUDED AS STANDARD)</p> <p><input type="checkbox"/> 7 COUNT REFILL PACKAGE FI-27791</p> <p><input type="checkbox"/> 100 COUNT REFILL PACKAGE FI-27794</p>
<p>CAPACITY</p> <p>SHORTENING/OIL: 73 lb (33 kg) MAXIMUM</p> <p>LOAD CAPACITY: 13 lb (6 kg) MAXIMUM</p>	<p>OPTIONS</p> <p><input type="checkbox"/> Basket, Full-Size (48 CHICKEN PIECE CAPACITY) BS-26998</p> <p>FILTERS</p> <p><input type="checkbox"/> Charcoal/Carbon (30 COUNT PKG.) FI-27648</p> <p><input type="checkbox"/> Reusable Mesh (SINGLE FILTER) FI-27014</p> <p><input type="checkbox"/> Fry Pot Cover 5005136</p> <p><input type="checkbox"/> Mobile Drawer Cover 5006073</p> <p><input type="checkbox"/> Strainer/Skimmer CE-27400</p> <p><input type="checkbox"/> Oil Discard Hose HO-27686</p> <p><input type="checkbox"/> Banking Strip (1 STRIP REQ'D FOR EVERY 2 BANKED FRYERS) 5008809</p> <p><input type="checkbox"/> Mobile Oil Caddy TO-28359</p> <p><input type="checkbox"/> Pre-filter Sieve Kit (FOR OIL FILTRATION SYSTEM) 5010451</p>
<p>WEIGHT EST.</p> <p>NET WEIGHT: 360 lb (163 kg)</p> <p>SHIP WEIGHT: 520 lb (236 kg)</p> <p>CARTON DIMENSIONS: H X W X D 57" x 34" x 47" (1448mm x 864mm x 1194mm)</p>	



ASF-75G WITH LIFTS AND FILTRATION

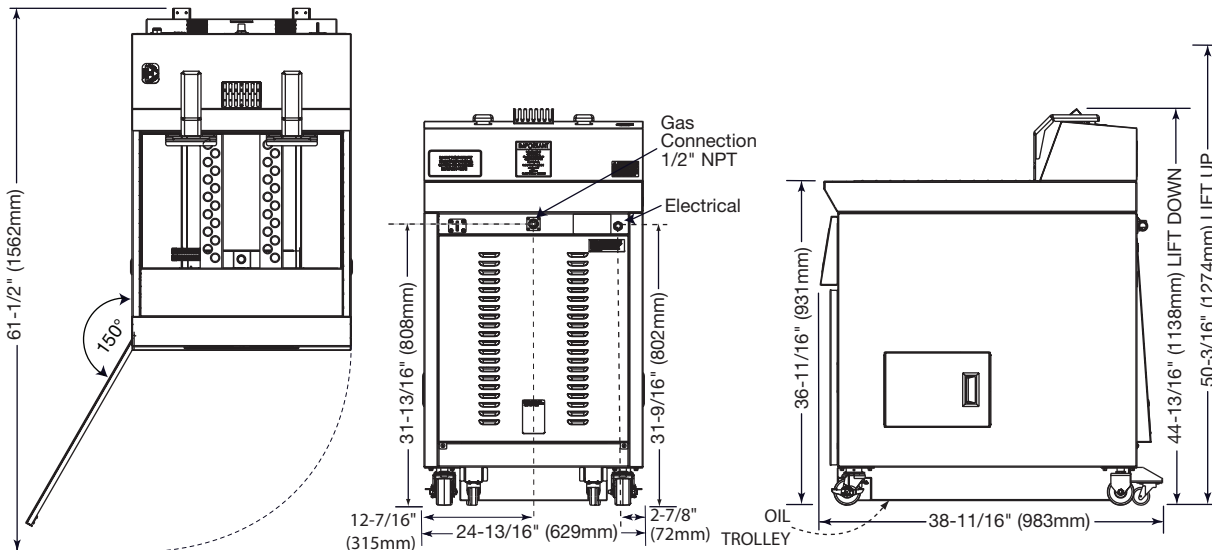

INSTALLATION

ASF-60G SPECIFICATIONS

DIMENSIONS EXTERIOR (H X W X D)		STANDARD ACCESSORIES	
ASF-60G WITHOUT BASKET LIFTS 44-3/4" x 15-3/4" x 33-5/8" (1136mm x 400mm x 853mm)		<input type="checkbox"/> Basket, Half-Size (2 INCLUDED AS STANDARD)	BS-27963
ASF-60G WITH BASKET LIFTS 44-3/4" x 15-3/4" x 33-5/8" (1136mm x 400mm x 853mm)		Brush Set (ONE 3-BRUSH SET INCLUDED AS STANDARD)	
BASKET DIMENSIONS (H X W X D) 5-3/16" x 5-7/8" x 13-13/16" (131mm x 149mm x 328mm)		<input type="checkbox"/> SCRUB BRUSH	BH-28693
		<input type="checkbox"/> STRAIGHT BRUSH	BH-28691
CAPACITY		OPTIONS	
SHORTENING/OIL: 62 lb (28 kg) MAXIMUM		<input type="checkbox"/> Fry Pot Cover	5007596
LOAD CAPACITY: 8 lb (4 kg) MAXIMUM		<input type="checkbox"/> Strainer/Skimmer	CE-27400
		<input type="checkbox"/> Banking Strip (1 STRIP REQ'D FOR EVERY 2 BANKED FRYERS)	1009367
		<input type="checkbox"/> Mobile Oil Caddy	TO-28359
WEIGHT			
NET WEIGHT:	248 lb (113 kg)		
SHIP WEIGHT:	330 lb (150 kg) EST		
CARTON DIMENSIONS:	39" x 22" x 55" EST		
H X W X D	(991mm x 559mm x 1397mm) EST		



ASF-60G WITH LIFTS

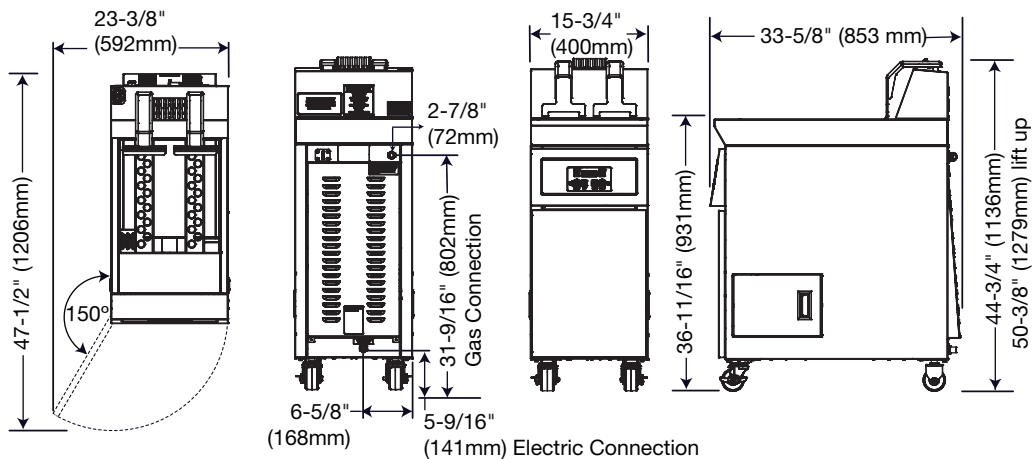

INSTALLATION

DANGER



IMPROPER INSTALLATION, ALTERATION, ADJUSTMENT, SERVICE, OR MAINTENANCE COULD RESULT IN SEVERE INJURY, DEATH, OR CAUSE PROPERTY DAMAGE.

READ THE INSTALLATION, OPERATING AND MAINTENANCE INSTRUCTIONS THOROUGHLY BEFORE INSTALLING OR SERVICING THIS EQUIPMENT.

DANGER



AVERTISSEMENT : UNE INSTALLATION, UN AJUSTEMENT, UNE ALTÉRATION, UN SERVICE OU UN ENTRETIEN NON CONFORME AUX NORMES PEUT CAUSER DES DOMMAGES À LA PROPRIÉTÉ, DES BLESSURES OU LA MORT.

LIRE ATTENTIVEMENT LES DIRECTIVES D'OPÉRATION ET D'ENTRETIEN AVANT DE FAIRE L'INSTALLATION, OU L'ENTRETIEN DE CET ÉQUIPEMENT.

CAUTION



METAL PARTS OF THIS EQUIPMENT BECOME EXTREMELY HOT WHEN IN OPERATION. TO AVOID BURNS, ALWAYS USE HAND PROTECTION WHEN OPERATING THIS APPLIANCE.

SITE INSTALLATION

NOTE: To avoid equipment damage, remove the Mobile Oil Trolley before moving this appliance with a forklift or pallet lift.

MINIMUM CLEARANCE REQUIREMENTS

	COMBUSTIBLE SURFACES	NON-COMBUSTIBLE SURFACES
RIGHT SIDE	0" (0mm)	0" (0mm)
LEFT SIDE	0" (0mm)	0" (0mm)
BACK	6" (152mm)	6" (152mm)
FRONT	25" (635mm)	

PLUS: 6" (152mm) minimum between the element swing in the extended position and the lower edge of the exhaust hood and filter media.

ENTRY CLEARANCE: 30" (762mm) UNCRATED

Ne pas installer à une distance inférieure à celle indiquée ce-dessous d'une paroi en matière combustible: Côtés 6 pouces, Arrière 6 pouces.

WARNING

MINIMUM CLEARANCES MUST REMAIN UNOBSTRUCTED.

DO NOT place insulation or any other type of materials in clearance areas.

CAUTION

DO NOT USE FORKLIFT FROM FRONT OR REAR OF UNIT. USE FORKLIFT FROM SIDE ONLY.

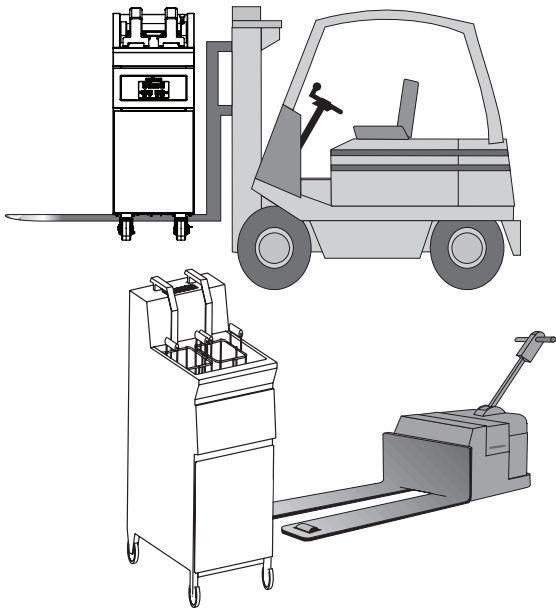

INSTALLATION

SITE INSTALLATION

1. It is the responsibility of the installer to verify that this fryer installation is in compliance with the specifications listed in this manual and with local code requirements.
2. Hood installation is required.
3. Both cooking and cleaning functions require unobstructed access. The frypot, control panel, and front access door must be maintained free from obstruction. The access door must be accessible for service and maintenance.
4. Locate the fryer on a firm, level surface ONLY. The area surrounding the fryer must be kept clear of all combustible materials.
5. **FOR YOUR SAFETY DO NOT** store or use any flammable liquids or allow flammable vapors in the vicinity of this fryer or any other appliance.
6. **FOR YOUR SAFETY DO NOT** place insulation or any other type of materials in clearance areas.
7. When properly installed, the electric fryer is designed for operation adjacent to non-combustible floors and walls with a 6" clearance at the back. Clearances from all combustible construction is a minimum of 6" (152mm) at the back and both sides. Concrete, tile, terrazzo, or metal surfaces are recommended. Metal over a combustible material may not meet code for non-combustible surfaces. Verify site selection with local codes for specific requirements. **Doit être utilisé seulement sur des planchers non inflammables.**
8. Adequate means must be provided to limit the movement of this appliance. A restraining device is required for field installation.

9. **DO NOT** install this fryer in any area where it may be affected by any adverse conditions such as steam or dripping water, etc. **DO NOT** install the fryer over a drain.
10. **LEVELING:** Make certain the fryer is positioned firmly on all four supporting casters. Level fryer front-to-back and side-to-side by holding lower collar (#2) while twisting upper collar (#1). Restraining ties can be used for stabilization if necessary. Use an allen wrench (#3) to lock caster in position.

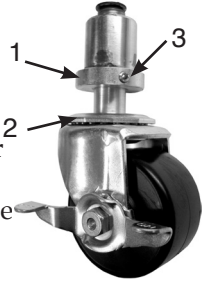

WARNING

BURN WARNING: Make certain the fryer is stabilized before operation to prevent any movement or tipping and the possibility of severe burns caused by hot, splashing shortening or oil.

CAUTION



TO PREVENT PERSONAL INJURY, USE CAUTION WHEN MOVING OR LEVELING THIS APPLIANCE.

DANGER



To avoid electrical shock, this appliance MUST be adequately grounded in accordance with local electrical codes or, in the absence of local codes, with the current edition of the National Electrical Code ANSI/NFPA No. 70. In Canada, all electrical connections are to be made in accordance with CSA C22.1, Canadian Electrical Code Part 1 or local codes.

WARNING



IMPROPER INSTALLATION MAY RESULT IN FIRE. Carefully read and follow all installation instructions located in this manual.

DANGER



Installation, air adjustment and/or service work must be in accordance with all local codes and must be performed by a certified service technician qualified to work on gas appliances.

WARNING

This appliance shall be installed in conformity with the current regulations and used only in a well ventilated location. Consult the instructions before installing and using this appliance.

An adequate ventilation system is required for commercial cooking equipment. Information may be obtained by writing to the National Fire Protection Association, Batterymarch Park, Quincy, MA 02269. When writing refer to NFPA No. 96.

1. A single ASF-75G or ASF-60G auto-lift gas fryer requires a minimum of 120 CFM make-up air for natural gas and 48 CFM for propane gas. Kitchen ventilation must be of sufficient capacity to prevent a negative-pressure condition. **DO NOT** obstruct or restrict ventilation nor the air flow required to support combustion.
2. **DO NOT** obstruct the flow of the exhaust flue at the top rear of the fryer. It is especially critical that gas supply piping and electrical support cord and/or receptacle be routed away from the path of the hot combustion fumes.
3. This fryer cannot be direct vented.
4. Install the fryer under a ventilation hood meeting all applicable code requirements. Combustion fumes must be vented in accordance with local, state, or national codes.

CAUTION



To prevent malfunction or cause negative back draft, **DO NOT** obstruct exhaust flues or attach any flue extension that will impede proper burner operation.



DANGER

**FAILURE TO VENT THIS FRYER PROPERLY
MAY BE HAZARDOUS TO THE
HEALTH OF THE OPERATOR.**

Equipment damage and operational problems may also be the consequence of improper venting. Any damages sustained by a failure to properly vent this fryer are not covered under warranty.

Ventilating hoods and exhaust systems shall be permitted to be used to vent appliances installed in commercial applications.

Where automatically operated appliances are vented through a ventilating hood or exhaust system equipped with a damper or with a power means of exhaust, provisions shall be made to allow the flow of gas to the main burners only when the damper is open to a position to properly vent the appliance and when the power means of exhaust is in operation. IN ACCORDANCE WITH NFPA 54 COMMONWEALTH OF MASSACHUSETTS ONLY.

INSTALLATION

GAS SPECIFICATIONS

The Alto-Shaam open gas fryer has been set to operate with either natural gas or propane as indicated on the fryer identification name plate.

! DANGER

CONNECTING TO THE WRONG GAS SUPPLY COULD RESULT IN FIRE OR AN EXPLOSION CAUSING SEVERE INJURY AND PROPERTY DAMAGE.

WARNING

TO AVOID SERIOUS PERSONAL INJURY, installation of this appliance must conform to local, state, and national codes; the current edition of the American National Standard Z223.1, National Fuel Gas Code, and all local municipal building codes. In Canada, installation must be in accordance with Standard CAN/CSA B 149.1 and Installation Codes - Gas Burning Appliances, and local codes.

INSTALLATION REQUIREMENTS
GAS CONNECTION: 1/2" NPT
CHECK PLUMBING CODES FOR PROPER SUPPLY LINE SIZING TO ATTAIN MINIMUM BURNER MANIFOLD PRESSURE SHOWN: NATURAL GAS: 5.0" W.C. PROPANE GAS: 10.0" W.C.
MAXIMUM INLET PRESSURE: 14" W.C.
NOTE: If a flexible gas line is used, it must be AGA approved, commercial type and at least 3/4" I.D.
HOOD INSTALLATION IS REQUIRED

Category	I _{2H} at 20 mbar for use in AT, DK, FI, IE, IT, PT, SE, CH.
Category	I _{2E(20)} at 20/25 mbar for use in DE, LU.
Category	I _{2E+(20/25)} at 20/25 mbar for use in BE, FR.
Category	I _{2L(25)} at 25 mbar for use in NL.
Category	I _{3+(28-30/37)} at 28-30/37 mbar for use in BE, FR, IE, IT, LU, PT, CH.
Category	I _{3B/P(30)} at 30 mbar for use in DK, FI, NL, SE.
Category	I _{3B/P(50)} at 50 mbar for use in AT, DE, CH.
Category	I _{3P(37)} at 37 mbar for use in FI, DE, IE, CH.

The appliance and its individual shutoff valve must be disconnected from the gas supply piping system during any pressure testing of that system at test pressures in excess of 1/2 psi. The appliance must be isolated from the gas supply piping system by closing its individual manual shutoff valve during any pressure testing of the gas supply piping system at test pressures equal to or less than 1/2 psi.

NOTE: Customer/installer must provide manual gas shut-off valve in accordance with local code requirements.

GAS PRESSURE CHART		
The fryer has been factory adjusted according to the gas type specified on the fryer identification name plate.		
GAS FRYER TECHNICAL SPECIFICATIONS		
Natural Gas ←		
Min. Connected Pressure	5.0" W.C.	1.2 kPa
Max. Connected Pressure	14.0" W.C.	3.5 kPa
Gas Consumption	120 CFM	
Gross Thermal Output	120,000 Btu/hr	
Propane Gas ←		
Min. Connected Pressure	10.0" W.C.	2.5 kPa
Max. Connected Pressure	14.0" W.C.	3.5 kPa
Gas Consumption	48 CFM	
Gross Thermal Output	120,000 Btu/hr	

GAS SPECIFICATIONS	
<input type="checkbox"/> NATURAL GAS	<input type="checkbox"/> PROPANE GAS
120,000 BTU/hr. INPUT	120,000 BTU/hr. INPUT

Declared input (kW)	35.15
Gas Group	I _{2H(20)} , I _{2E(20)} , I _{2E+(20/25)} , I _{2L(25)} , I _{3+(28-30/37)} , I _{3B/P(30)} , I _{3B/P(37)} , I _{3B/P(50)} , I _{3P(37)} , I _{3P(50)}
Inlet pressure (mbar)	17.5 (NAT) and 27.5 (LP)
Declared setting pressure at the outlet from the gas valve (mbar)	12.5 (NAT) and 25 (LP)
Main burner type	Infrared type with blower and venturi valve
Number of injectors	1
Main injector type	N/A
Main injector size and markings	N/A
Main burner aeration opening size	Variable pre-set at factory
Ignition	Direct spark electronic ignition
Inlet connection	20.995 mm male thread

INSTALLATION

GAS CONNECTION

DANGER



Installation, air adjustment and/or service work must be in accordance with all local codes and must be performed by a certified service technician qualified to work on gas appliances.

Use an approved gas pipe sealant at all external threaded connections, gas piping used on gas connections must avoid sharp bends that may restrict the flow of gas to the appliance. If the connected pressure exceeds 14.0" W.C. (3.5 kPa), a step-down regulator is required to be supplied by the owner/operator.

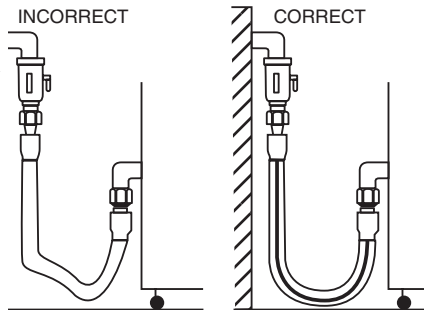

Close the individual manual shut-off valve to **isolate the fryer** from the gas supply piping system during any pressure testing at test pressures equal to or less than 1/2 psig. (3.4 kPa). The fryer and individual shut-off valve **must be disconnected** from the gas supply piping system during any pressure testing at pressures in excess of 1/2 psig. (3.4 kPa).

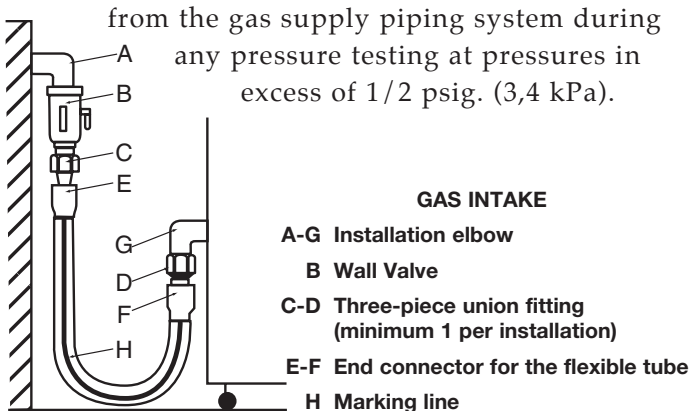

In the U.S.A., installation must conform to local codes or, in the absence of local codes, with the current edition of the *National Fuel Gas Code*, NFPA-54 and ANSI Z83.11a CSA 1.8a 2004 (or latest edition). In Canada, installation must be in accordance with local codes, CAN/CGA-B149.1, *Installation for Natural Gas Burning Appliances and Equipment* (latest edition) or CAN/CGA-B149.2 *Installation for Propane Burning Appliances and Equipment* (latest edition).

The inlet supply line must be properly sized to accommodate all individual appliances simultaneously used on the same line but must never be smaller than 3/4" I.D.

LEAK TESTING

Installation requires gas leak testing on all gas piping and fittings. Use an approved electronic leak device or a soap and water solution at all gas connections. If bubbling appears when using a soap and water solution, the connection must be refitted. Never use an open flame to leak test.



DANGER



NEVER USE AN OPEN FLAME TO LEAK TEST.

INSTALLATION

RESTRAINT REQUIREMENTS - MOBILE EQUIPMENT

The fryer must be supplied with a connector that complies with all state and local installation codes.

Any appliance that is not furnished with a power supply cord but that includes a set of casters must be tethered. Adequate means must be provided to limit the movement of this appliance without depending on or transmitting stress to the electrical conduit. The following requirements apply:

1. Casters must be a maximum height of 4-inches (102mm).
2. Such mobile appliances must be installed with the use of a flexible connector secured to the building structure.

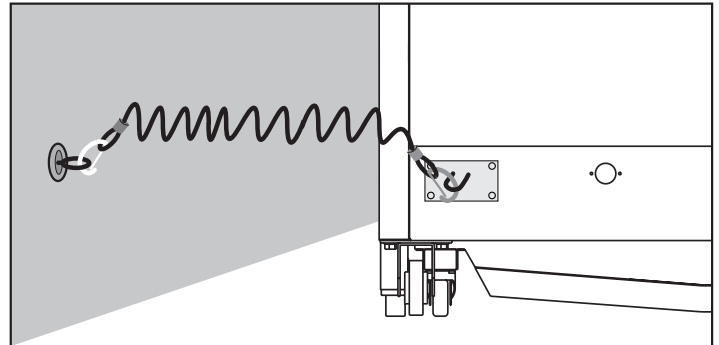

A mounting connector for a restraining device is located on the lower back flange of the appliance chassis, approximately 7-inches (178mm) from the floor. A flexible connector is not supplied by nor is it available from the factory.

 WARNING	
	RISK OF ELECTRIC SHOCK. Appliance must be secured to building structure.

INSTALLATION

ELECTRICAL REQUIREMENTS

DANGER



To avoid electrical shock, this appliance **MUST** be adequately grounded in accordance with local electrical codes or, in the absence of local codes, with the current edition of the National Electrical Code ANSI/NFPA No. 70. In Canada, all electrical connections are to be made in accordance with CSA C22.1, Canadian Electrical Code Part 1 or local codes.



DANGER



ENSURE POWER SOURCE MATCHES VOLTAGE STAMPED ON APPLIANCE NAMEPLATE.

230V:

To prevent an electrical shock hazard between the appliance and other appliances or metal parts in close vicinity, an equalization-bonding stud is provided. An equalization bonding lead must be connected to this stud and the other appliances / metal parts to provide sufficient protection against potential difference. The terminal is marked with the following symbol. 

Hard wired models:



Hard wired models must be equipped with a country certified external allpole disconnection switch with sufficient contact separation.



If a power cord is used for the connection of the product an oil resistant cord like H05RN or H07RN or equivalent must be used.

An electrical wiring diagram is located in the front access door of the fryer. The fryer must be installed by a qualified electrician. This appliance must be branch circuit protected with proper ampacities, in accordance with the wiring diagram located in the fryer. The fryer must be properly grounded in accordance with the National Electrical Code and applicable local codes. A means to disconnect the unit must be incorporated into the fixed wiring in accordance with wiring codes.

Wire size for the main incoming power to the unit must match the minimum size listed in the specifications applicable to the specific fryer. For supply connections, locate the wire size posted on the label located on the electrical control box cover, behind the service panel or elsewhere listed in this manual.

Before operating the fryer, check all cable connections in the electrical connection area for tightness since connections can loosen during transport.

ELECTRICAL • ASF-60G WITH BASIC CONTROL						
VOLTAGE	PHASE	CYCLE/HZ	AMPS	kW	CORD & PLUG	
120 (AGCY)	1	60	2.2	0.27		NEMA 5-15P 15A-125V PLUG
230	1	50	1.0	0.23		CEE 7/7 220-230V PLUG

ELECTRICAL • ASF-75G WITH BASIC CONTROL						
VOLTAGE	PHASE	CYCLE/HZ	AMPS	kW	CORD & PLUG	
120 (AGCY)	1	60	7.2	0.86		NEMA 5-15P 15A-125V PLUG
230 (AGCY)	1	50	4.0	0.92		CEE 7/7 220-230V PLUG

OPERATION

OIL/SHORTENING REQUIREMENTS

OIL/SHORTENING REQUIREMENTS

The ASF-75G requires 73-pounds (33 kg) of oil or shortening in the frypot and the ASF-60G requires 62-pounds (28 kg) of oil or shortening. Use only quality, high-grade oil/shortening in the fryer. The high moisture content of many lower grade shortening will result in excessive foaming and boil over. The cold oil/shortening level requirement for the fryer is indicated below.

CAUTION

Cold oil or shortening expands as the temperature increases. To avoid injury and equipment damage, allow for expansion by filling to the cold oil fill line.

NOTE: ALWAYS maintain the proper level of shortening by adding fresh oil/shortening to the frypot whenever needed.

**FRYER CROSS-SECTION
OIL/SHORTENING LEVELS**

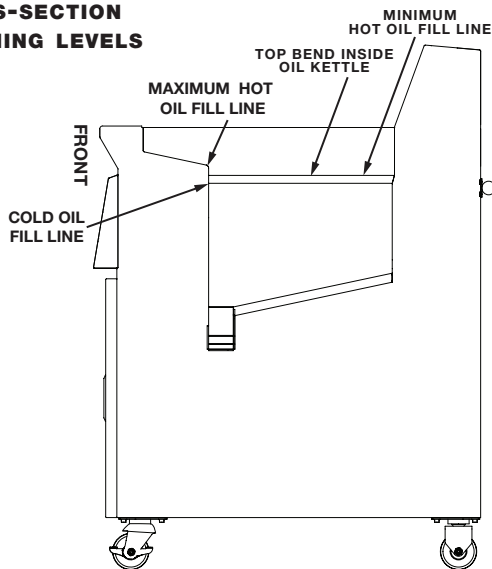

WARNING

FAILURE TO PLACE SOLID SHORTENING DIRECTLY ON THE BOTTOM OF THE FRYPOT CAN CAUSE SERIOUS EQUIPMENT DAMAGE.



DANGER



**FLASH
POINT**

The flash point of shortening occurs at a lower temperature the longer the shortening is used. Discard any shortening showing signs of deterioration to avoid serious burns, fire, and property damage.

Check the quality of the oil/shortening in the frypot on a daily basis for signs of deterioration. Use an approved test kit. Signs of shortening deterioration include excessive boiling, smoking, foaming, bad taste, and rancid odor. Discard any shortening before it degrades to the point of affecting product quality. Always filter the oil on a regular basis and keep the frypot clean.

CAUTION

ENSURE THERE IS NO WATER IN THE FRYPOT BEFORE FILLING WITH OIL/SHORTENING. WHEN COOKING COMPOUNDS ARE HEATED TO COOKING TEMPERATURE, WATER IN THE FRYPOT WILL CAUSE OIL TO SPLATTER AND MAY BE A BURN HAZARD.

Remove ice crystals and ensure that food is dry before frying. Excessive water and ice can cause oil to splatter or overflow. Do not over fill the basket. Food needs to be surrounded by oil for best frying results.

Maximum shortening life is achieved by lowering the temperature of the fryer to 250°F (121°C) or turning the fryer station off when not in use. In multiple-station units, heat only the component fryers necessary to meet cooking needs.

CAUTION

FIRE OR EQUIPMENT DAMAGE CAN RESULT FROM IMPROPER SHORTENING LEVELS. THE LEVEL OF SHORTENING MUST ALWAYS BE ABOVE THE HEAT EXCHANGERS WHEN THE FRYER IS OPERATING. THE REQUIRED SHORTENING LEVEL MUST ALWAYS BE ABOVE THE MINIMUM HOT OIL FILL LINE.

CAUTION



METAL PARTS OF THIS EQUIPMENT BECOME EXTREMELY HOT WHEN IN OPERATION. TO AVOID BURNS, ALWAYS USE HAND PROTECTION WHEN OPERATING THIS APPLIANCE.

OPERATION

CONTROLS BEHIND ACCESS PANEL

ASF-60G, 120V

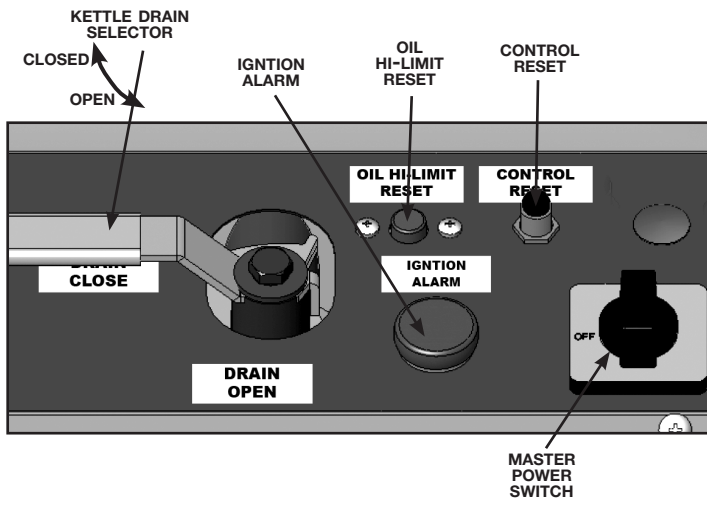

ASF-60G, 230V

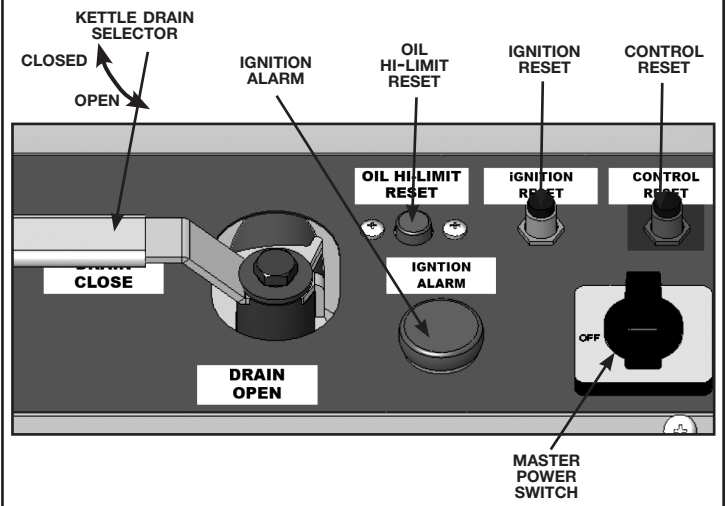

ASF-75G, 120V WITH FILTRATION

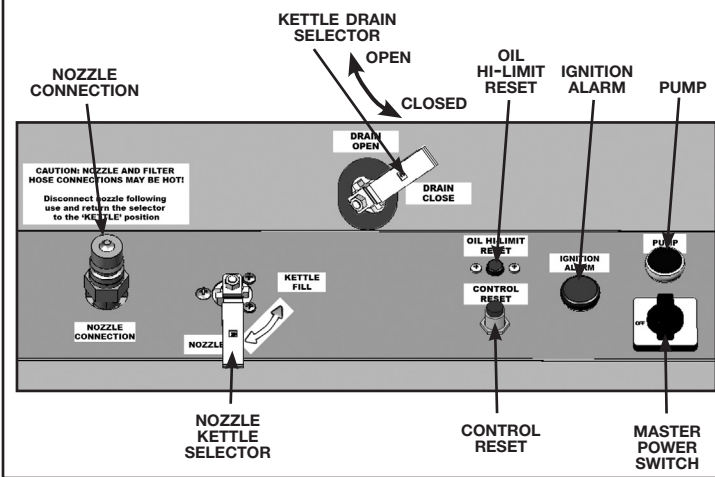

ASF-75G, 230V

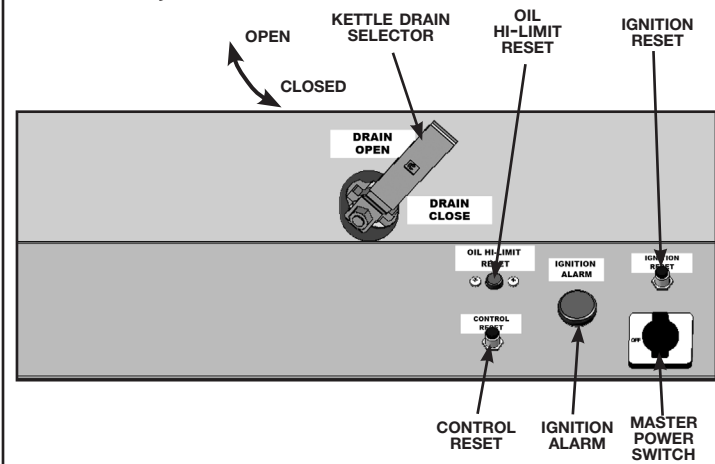

OPERATION

BOIL-OUT PROCEDURE

NOTE: Perform an initial boil-out to clean and sanitize the fryer before operating.

Carbonized deposits along with an accumulation of oil will eventually build-up on the interior of the frypot as well as fryer accessories. It is important to periodically remove these deposits, not only to maintain fryer efficiency, but also to provide the highest product quality.

NOTE: Always wear eye protection or a face shield and protective rubber gloves when cleaning the frypot as boil-out chemical is an alkaline solution and can cause severe burns.

NOTE: Because each fryer is controlled separately, the following procedure must be followed for every unit in multiple-fryer units.

CAUTION

BEFORE ENTERING THIS PROGRAM, MAKE CERTAIN THE FRYPOT IS EMPTY OF ALL OIL OR SHORTENING.

CAUTION

TO AVOID DAMAGING THE PUMP AND CONTAMINATING CLEAN OIL WITH BOIL-OUT CHEMICAL ON UNITS EQUIPPED WITH A FILTRATION SYSTEM, NEVER ALLOW BOIL-OUT SOLUTION OR RINSE WATER TO CIRCULATE THROUGH THE FRYER PUMP SYSTEM.

CAUTION

BOIL-OUT SOLUTION AND SURROUNDING METAL SURFACES BECOME EXTREMELY HOT. TO AVOID BURNS, ALWAYS USE HAND PROTECTION WHEN PERFORMING THE BOIL-OUT FUNCTION AND FOLLOW THE MANUFACTURER'S SAFETY INSTRUCTIONS FOR THE BOIL-OUT PRODUCT BEING USED.

CAUTION

DO NOT LEAVE THE FRYER UNATTENDED DURING THE BOIL-OUT PROCESS. THE FRYER MUST BE CONTINUOUSLY MONITORED FOR BOIL-OVER CONDITIONS, PARTICULARLY IN HIGH-ALTITUDE LOCATIONS. IF BOIL-OVER IS IMMINENT, IMMEDIATELY TURN THE MASTER POWER SWITCH OFF AND ALLOW THE SOLUTION TO COOL. WHEN THE SOLUTION HAS COOLED, RE-ENTER THE BOIL-OUT MODE.

NOTE: Manual Boil-Out can only be performed when the actual temperature of the frypot is less than 230°F (110°C).

1. Place the mobile oil drawer or heat safe container under the drain. Rotate drain valve to **"OPEN"** to drain oil. If equipped with the optional oil hand wand, use the wand to pump oil into the frypot to further rinse food particles out of the frypot. Carefully disconnect the wand from fryer and drain any residual oil from the wand into the frypot and then drain the remaining oil from frypot.
2. While wearing heat resistant gloves, wipe excess oil out of inside of frypot with paper towel or clean rag.
3. If oil has been drained into a mobile oil drawer, empty the oil from the drawer. Wash the oil drawer, rinse with clean water, and dry drawer thoroughly.
4. If the fryer is equipped with a filtration system, clean or replace the filter in the filter cartridge and remove cartridge from unit. (See filtration instructions on page 19.)
5. Open the front access door. If equipped with a filtration system, rotate the Kettle/Nozzle selector to the **"KETTLE"** position, then rotate the drain valve clockwise until rotation stops and the drain valve is **"CLOSED."**
6. Fill the fryer to the maximum oil fill line with water.

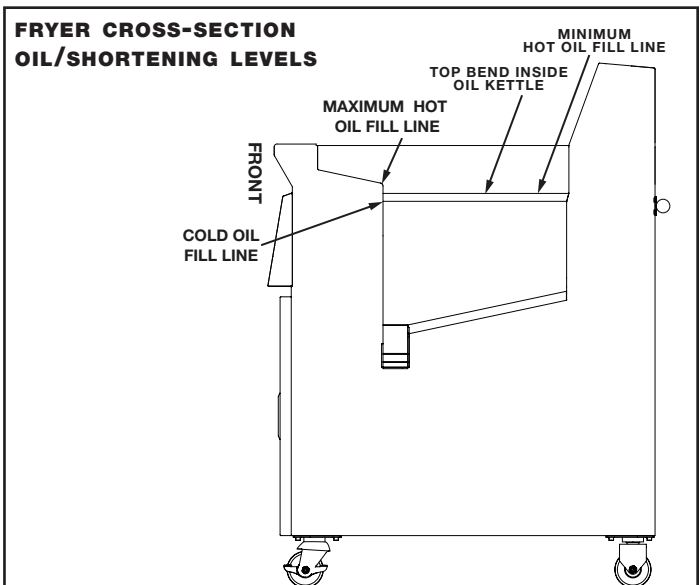

CAUTION

KEEP A CONTAINER OF COLD WATER ON HAND DURING BOIL-OUT IN CASE OF BOIL-OVER. IF BOIL-OVER IS IMMINENT, IMMEDIATELY TURN OFF MASTER POWER SWITCH AND POUR COLD WATER INTO FRYPOT TO QUICKLY REDUCE SOLUTION TEMPERATURE.

7. Add boil out solution. Carefully follow the manufacturer's directions for mixing the boil-out solution.
8. Turn the Master Power Switch (located behind the front access door) to the **"ON"** position and press the **CONTROL RESET**.
9. Wait until the **LED** reads **"HEAT"**, then press the **BOIL OUT** button  on the control panel.
10. When 192°F (89°C) is reached, the **LED** will display **"bOIL"**, the temperature will be maintained. Using a separate timer, allow the frypot to boil-out for 10 minutes.
11. After the 10 minute boil-out period, turn the Master Power Switch located behind the front access door to the **"OFF"** position.
12. Wearing protective gloves to avoid burns, scrub the inside of the frypot with a long-handled scrub brush.
13. Place another empty and dry mobile oil drawer or heat safe container under the drain. Rotate the drain to the **"OPEN"** position. **The handle should be rotated counterclockwise until it stops.** Allow the boil-out solution to completely drain into mobile oil drawer or a heat safe container. Discard boil-out solution. Return the drawer to the fully-inserted position beneath the fryer.
14. Making sure the drain is **"OPEN"**, rinse all boil-out solution from fry pot, drain, burner holes, etc. Follow the boil-out solution manufacturer's additional boil-out instructions to rinse the frypot in order to neutralize boil-out cleaner residue. Discard rinse solution.
15. There may be residual boil-out solution in the oil fill-hole and tube. This must be flushed out and discarded separately before filling the tank with new oil to avoid contamination of new oil.

For filtration-equipped fryers: Place a small amount of clean, liquid oil in the clean fat drawer. Pump a small amount of oil through the the system. While wearing heat resistant gloves, catch the oil that is pumped through the fill hole inside frypot with paper towel. Drain the oil. Rinse fry pot with a small amount of water.

For units without a pump or filtration system: Pour a small amount of oil into the the fryer and drain it into a separate container. Rinse frypot and frypot drain with water.

CAUTION

ENSURE THERE IS NO WATER IN THE FRYPOT BEFORE FILLING WITH OIL/SHORTENING. WHEN COOKING COMPOUNDS ARE HEATED TO COOKING TEMPERATURE, WATER IN THE FRYPOT WILL CAUSE OIL TO SPLATTER AND MAY BE A BURN HAZARD.

16. Following the boil-out and rinse procedure, wipe dry all accessible interior metal surfaces and interior accessories with a clean, dry cloth to remove remaining moisture. Clean and dry the fry baskets separately.
- NOTE: Make sure the inside of the frypot, the drain opening and all parts that come into contact with new oil/shortening are as dry as possible.**
17. Wipe the exterior of the fryer cabinet with a degreaser/sanitizer suitable for use on food contact surfaces. Always follow the manufacturer's instructions and/or mixing directions for proper solution strengths.

Wipe exterior stainless steel surfaces with the grain of the metal and avoid the use of abrasive pads, steel wool, or metal implements.
 18. Rotate drain to **"CLOSED"** position.
 19. Replace the oil filter if equipped with filtration system. (See instructions on pages 19.)
 20. Fill tank with new oil or shortening.

OPERATION

START UP & GENERAL OPERATION

DANGER



BEFORE STARTING THE APPLIANCE, MAKE CERTAIN YOU DO NOT DETECT THE ODOR OF GAS.

IF THE ODOR OF GAS IS DETECTED:

- **DO NOT** attempt to light any appliance.
- **DO NOT** touch any electrical switches.
- Extinguish any open flame.
- Use a telephone **OUTSIDE THE PROPERTY & IMMEDIATELY** contact your gas supplier.
- If unable to contact your gas supplier, contact the fire department.

NOTE: Perform an initial Boil-Out to clean and sanitize the fryer station before operating. (See page 14.)

1. Service is to be performed by an authorized Alto-Shaam service agent.
2. Ensure all local electrical codes, fire codes, and all other requirements such as hood installation have been met in the process of installation

NOTE: Because each fryer station is controlled separately, the following procedures must be followed for every component fryer in multiple-station units.

3. Open front access door and ensure drain valve is in the **CLOSED** position. The handle should be rotated clockwise until it stops.
4. Fill frypot with frying compound as indicated. (SEE ILLUSTRATION ON THE OIL/SHORTENING REQUIREMENTS PAGE)
5. The Master Power Switch is located behind the front access door. Turn Master Power Switch **“ON.”**
6. Press the **CONTROL RESET** button.
7. The **LED** display on the basic control panel will indicate **“-AS-”**, the software version, and then **“CH”**.
8. When the fryer has reached 135°F, the melt cycle is complete and the **LED** display on the control panel will indicate **“HEAT”**.

9. When the fryer displays the set-point temperature, product can be fried.
10. More detailed operating guidelines along with information on programming are located within this manual.
11. To shutdown the fryer, turn the Master Power Switch located behind the front access door to the **“OFF”** position.

NOTE: FOR YOUR PROTECTION The fryer station is furnished with a hi-limit safety shutoff that will disengage the control if the frying compound temperature in the frypot would ever exceed 415°F (213°C). The **LED** will display **“Hi”**, the heat will shut off, the timer will be cancelled, and a constant alarm will sound. In this event, allow the frying compound temperature to drop below 415°F (213°C). Open the front access door and press the **OIL HI-LIMIT RESET** button for a period of 3-seconds to restart the control.

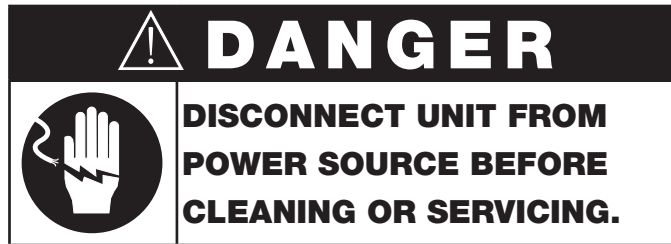

THOROUGHLY CLEAN DAILY

The cleanliness and appearance of this unit will contribute considerably to operating efficiency and savory, appetizing food.

Good equipment kept clean works better and lasts longer.

1. Disconnect unit from power source, and let cool.
2. Remove all detachable items. Clean these items separately with a good grease solvent or commercial detergent. Rinse well and dry.
3. Clean control panel, door vents, door handles, and door gaskets thoroughly since these areas harbor food debris. Rinse by wiping with sponge and clean warm water. Wipe dry with a clean cloth.

4. To help maintain the protective film coating on polished stainless steel, clean the exterior of the unit with a cleaner recommended for stainless steel surfaces. Spray the cleaning agent on a clean cloth and wipe with the grain of the stainless steel.

NOTE: Avoid the use of abrasive cleaning, compounds, chloride based cleaners, or cleaners containing quaternary salts. Never use hydrochloric acid (muriatic acid) on stainless steel.

Always follow appropriate state or local health (hygiene) regulations regarding all applicable cleaning and sanitation requirements for foodservice equipment.

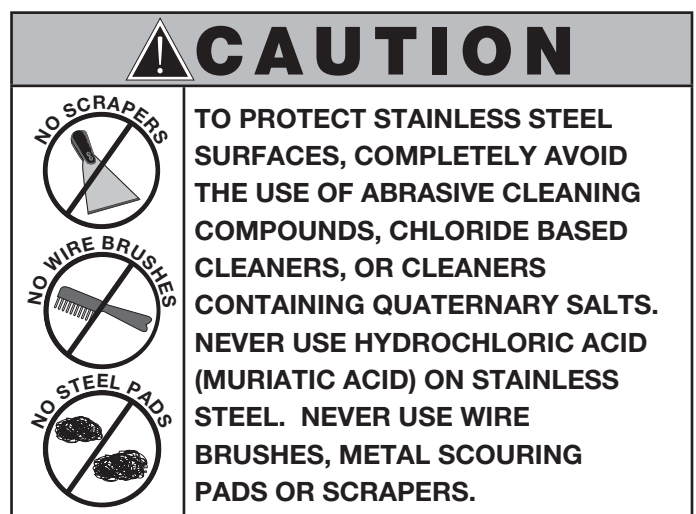
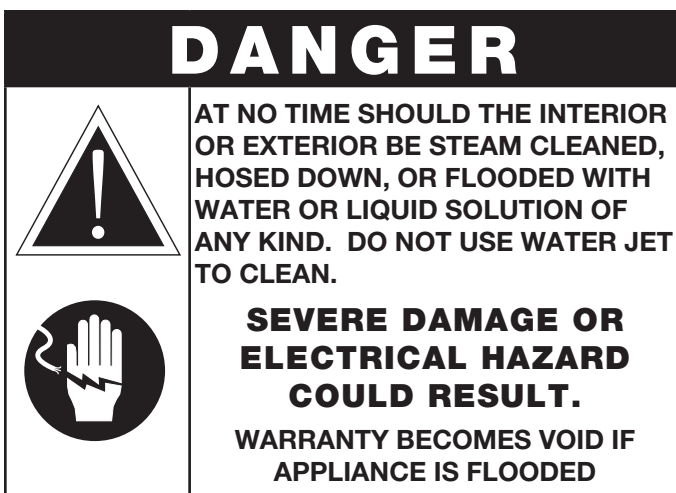

OPERATION

OIL FILTRATION INSTRUCTIONS (FOR UNITS WITH INSTALLED OPTION)

Careful observation of the finished food product will help determine optimal filtering frequency. Filtering the cooking oil at regular intervals will help ensure food quality.

FOR BEST RESULTS: Do not allow the temperature of the oil to decrease below the **"Idle Mode"** temperature of 250°F (121°C) when filtering. If filtering at the end of the day, pump oil back into the kettle while still hot. Do not allow oil to cool before returning to kettle.

CAUTION

OPERATORS MUST BE MADE AWARE OF THE HAZARDS INVOLVED IN THE OPERATION OF A HOT OIL FILTERING SYSTEM. ON-SITE SUPERVISION DURING THE FILTRATION PROCESS AND THE CLEANING PROCESS IS STRONGLY RECOMMENDED.

CAUTION



METAL PARTS OF THIS EQUIPMENT BECOME EXTREMELY HOT WHEN IN OPERATION. TO AVOID BURNS, ALWAYS USE HAND PROTECTION WHEN OPERATING THIS APPLIANCE.

1. Open the front access door. With the Nozzle selector in the **"KETTLE FILL"** position, rotate the drain valve counterclock-wise until rotation stops and the drain valve is in the **"OPEN"** position. Power to the main control panel will automatically switch **"OFF."**
2. Allow contents of the fryer to completely drain into fat drawer.
3. Press the **PUMP "ON"** to allow the oil to circulate through the drain system to flush crumbs. Using the brushes provided, brush the sides and bottom of the fryer while the oil is circulating through the system. Use the angle brush under the heat exchangers.
4. Press the **PUMP "OFF"** and allow contents of the fryer to completely drain.
5. Rotate the drain valve clockwise to the **"CLOSED"** position.

6. Press the **PUMP "ON"** and allow the fryer to refill to the recommended level adding additional oil/shortening as required to maintain proper fill level.
7. Press the **PUMP "OFF"** button.
8. After the frypot has completely refilled, pull out the mobile oil trolley and discard the disposable paper or carbon filter into a proper receptacle or clean off reusable mesh filter. Clean the filter assembly and oil trolley, if needed.
9. Replace the oil filter and return the trolley to the proper position beneath the fryer.
10. Push the **ELEMENT HI LIMIT** reset button.
11. Press and hold the **"ON/OFF"** key on the main control panel for 1-1/2 to 2 seconds to energize the fryer. Continue normal fryer operation after the preheat function has been completed.

WARNING



TO AVOID PERSONAL INJURY, USE CAUTION WHEN SURFACES BECOME SLIPPERY DUE TO SPILLED OR DRIPPING OIL.

OIL FILTRATION INSTRUCTIONS (FOR UNITS WITH INSTALLED OPTION)

FILTER REPLACEMENT

1. With the **DRAIN** in the “**CLOSED**” position, pull the trolley from the fryer and disconnect the hose from the fryer. Take care when pulling trolley from fryer as it has sharp edges.

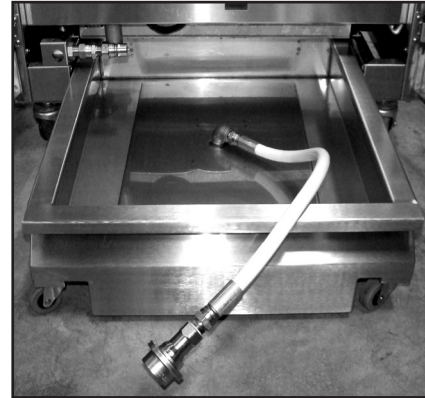

2. Pushing down on filter frame **4** clip, pull side of filter cartridge **1** closest to clip upwards. Slide opposite edge of filter cartridge out from beneath the filter frame lip.
3. Remove used filter **2** and filter ring **3**. Discard filter **2**. Retain filter ring **3**.
4. Place new filter **2** and filter ring **3** next to screen on underside of filter cartridge **1**. Reverse step 2 above.
5. Reconnect hose to fryer and return trolley to the full position under the fryer.

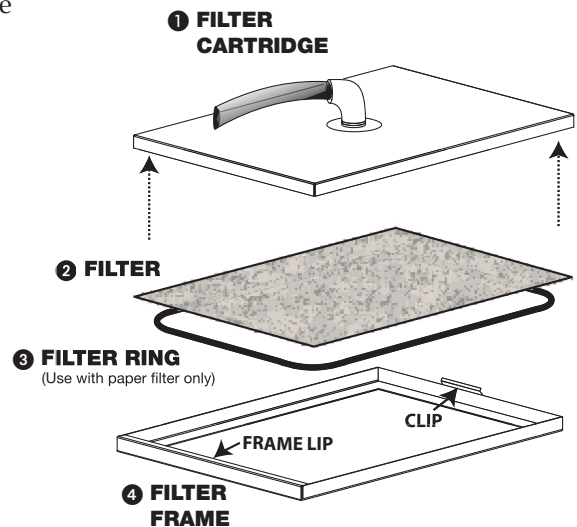

STANDARD AND OPTIONAL FILTERS	
PART NO.	DESCRIPTION
FI-27791	PAPER (STANDARD WITH FRYER) 7-count package
FI-27794	PAPER (STANDARD WITH FRYER) 100-count package
FI-27648	CHARCOAL / CARBON FILTER 30-count pkg.
FI-27014	REUSABLE MESH FILTER, single

OPERATION

OIL FILTRATION INSTRUCTIONS (FOR UNITS WITH INSTALLED OPTION)

FILTER CLEANING & MAINTENANCE

NOTE: Make certain to use hand protection when working with hot surfaces.

REUSABLE MESH FILTER OPTION:

Clean the reusable mesh filter (**FI-27014**) by spraying thoroughly with hot water. **DO NOT** clean in the dishwasher. **DO NOT** use detergents to clean. Detergents and detergent residues will significantly reduce the life of oil and shortening products.

Make certain the filter is securely fastened to the support basket before returning the assembly to the trolley.

To discard deteriorated oil/shortening, the trolley can be pulled from the fryer and can be rolled to a convenient location for use with a pumping device.

ALWAYS MAKE CERTAIN THE TROLLEY IS PROPERLY POSITIONED BENEATH THE FRYER BEFORE OPERATION.

CAUTION

A WORN FILTER WILL AFFECT PRODUCT FRYING RESULTS.

Make certain the filter is performing efficiently by inspecting the filter each time it is cleaned. Examine for cuts and holes. For the best results, replace the filter whenever necessary.

CAUTION

TO PREVENT FILTER DAMAGE, DO NOT USE SHARP IMPLEMENTS TO REMOVE SCRAPS FROM THE FILTER.

WARNING



TO AVOID PERSONAL INJURY, USE CAUTION WHEN SURFACES BECOME SLIPPERY DUE TO SPILLED OR DRIPPING OIL.

CAUTION



METAL PARTS OF THIS EQUIPMENT BECOME EXTREMELY HOT WHEN IN OPERATION. TO AVOID BURNS, ALWAYS USE HAND PROTECTION WHEN OPERATING THIS APPLIANCE.

OIL FILTRATION INSTRUCTIONS (FOR UNITS WITH INSTALLED OPTION)

CLEANING & MAINTENANCE

OIL DISCARD HOSE OPTION:

The oil discard hose option (HO-27686) is available as an option to assist both the boil-out and filtration operation.

With the discard hose attached to the nozzle connection, place the Kettle/Nozzle selector in the “**NOZZLE**” position.

The drain can be placed in the “**OPEN**” or “**CLOSED**” position as required.

Disconnect hose following use and return the selector to the “**KETTLE FILL**” position.

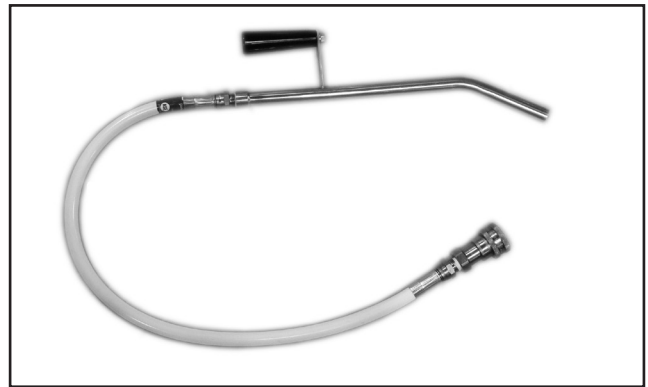

Nozzle will contain a small amount of oil after use. Dispose of properly.

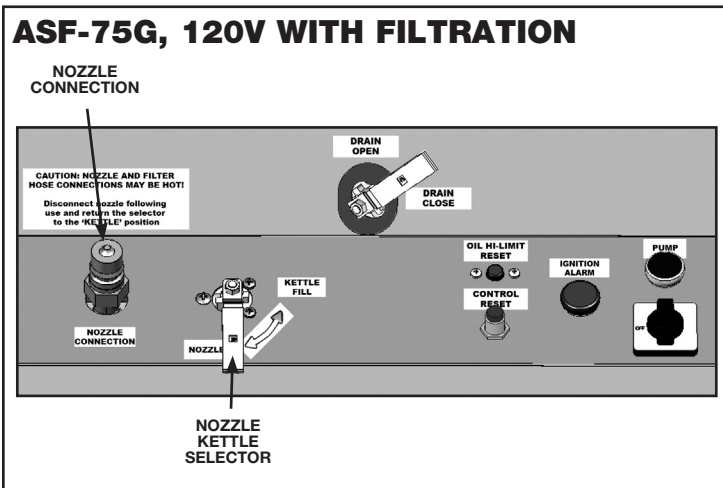

DANGER



TO AVOID SERIOUS PERSONAL INJURY DO NOT STAND ON THE FRYER OR FRYER COVER. THE FRYER COVER IS DESIGNED TO HOLD A MAXIMUM OF 10-POUNDS (4,5 KG) OF WEIGHT.

OPERATION

ALL SUGGESTED FRYING TIMES ARE BASED ON A FULL LOAD OF PRODUCT

Remove ice crystals and ensure that food is dry before frying. Excessive water and ice can cause oil to splatter or overflow. Do not over fill the basket. Food needs to be surrounded by oil for best frying results.

SUGGESTED FRYING TIMES

ITEM		MINUTES	TEMPERATURE	DISPLAY
PROGRAM KEYS	1. Fries (FROZEN)	3:30	350°F (177°C)	Fries
	2. Chicken Nuggets (FROZEN)	3:30	350°F (177°C)	Nuggets
	3. Fish, Breaded (FROZEN)	4:30	350°F (177°C)	Fish
	4. Chicken Pieces, Breaded (FRESH)	17:00	340°F (171°C)	Chicken
	5. PRODUCT A			ProductC
	6. PRODUCT B			ProductD

ITEM	MINUTES	TEMPERATURE
Appetizer	3:30	350°F (177°C)
Breaded Cauliflower	3:30	340°F (171°C)
Breaded Fish	Per pkg. instructions	340°F (171°C)
Breaded Mac & Cheese	3:30	340°F (171°C)
Breaded Mushrooms	3:30	340°F (171°C)
Broccoli Cheese Nuggets	2:30	350°F (177°C)
Cheese Cake, Fried	8:30	350°F (177°C)
Cheese Nuggets	1:30	350°F (177°C)
Chicken Breasts (FRESH)	12:00-17:00	315°F (171°C)
Chicken Breasts (FROZEN)	20:00	330°F (166°C)
Chicken Fried Steak	4:00	350°F (177°C)
Chicken Gizzards (FRESH)	3:30	350°F (177°C)
Chicken, Legs & Wings (FRESH)	12:00-17:00	315°F (171°C)
Chicken Legs (FROZEN)	18:00	330°F (166°C)
Chicken, Patty	6:00	350°F (177°C)
Chicken Pieces - MRB (FROZEN)	17:00	340°F (171°C)
Chicken Strips	6:00	340°F (171°C)
Chicken Tenderloins (FRESH)	3:00	350°F (177°C)
Chicken Tenders, Breaded (FROZEN)	3:30	350°F (177°C)
Chicken Wings (FRESH)	3:30	350°F (177°C)
Chicken Wings (FROZEN)	15:00	330°F (177°C)
Clam Strips	2:00	340°F (171°C)
Corn Dogs	10:00	350°F (177°C)
Cream Cheese Jalapeño Poppers	3:30	340°F (171°C)

THE TIMES AND TEMPERATURES ARE SUGGESTED GUIDELINES ONLY. ALL COOKING SHOULD BE BASED ON INTERNAL PRODUCT TEMPERATURES. DUE TO VARIATIONS IN PRODUCT QUALITY, WEIGHT, AND DESIRED DEGREE OF DONENESS, THE COOKING TIMES AND TEMPERATURES MAY NEED TO BE ADJUSTED ACCORDINGLY. ALWAYS FOLLOW LOCAL HEALTH (HYGIENE) REGULATIONS FOR ALL INTERNAL TEMPERATURE REQUIREMENTS.

OPERATION

ALL SUGGESTED FRYING TIMES ARE BASED ON A FULL LOAD OF PRODUCT

Remove ice crystals and ensure that food is dry before frying. Excessive water and ice can cause oil to splatter or overflow. Do not over fill the basket. Food needs to be surrounded by oil for best frying results.

SUGGESTED FRYING TIMES		
ITEM	MINUTES	TEMPERATURE
Eggplant	4:00	340°F (171°C)
Egg Rolls (FROZEN)	5:00	340°F (171°C)
Fries, Crinkle-Cut	5:00	340°F (171°C)
Fries, Seasoned	4:00	340°F (171°C)
Fries, Sour Cream & Chive	4:00	340°F (171°C)
Fries (FRESH)	5:00	340°F (171°C)
Fries, Thin Cut	3:30	340°F (171°C)
Hash Brown Circles	4:00	340°F (171°C)
Jalapeno Peppers, Stuffed	4:00	350°F (177°C)
Mozzarella Sticks, Battered or Breaded	Per pkg. instructions	340°F (171°C)
Mushrooms, Breaded	3:30	350°F (177°C)
Onion Rings	3:00	340°F (171°C)
Pork Chops (FRESH)	10:00	340°F (171°C)
Pork (FRESH)	12:00	340°F (171°C)
Potato Chips (fresh)	2:45	325°F (163°C)
Potato Wedges	3:00	350°F (177°C)
Quesadilla Rolls	3:30	350°F (177°C)
Shrimp	3:30	340°F (171°C)
Vegetables	3:00	350°F (177°C)
Zucchini, Breaded (FRESH)	3:30	350°F (177°C)

THE TIMES AND TEMPERATURES ARE SUGGESTED GUIDELINES ONLY. ALL COOKING SHOULD BE BASED ON INTERNAL PRODUCT TEMPERATURES. DUE TO VARIATIONS IN PRODUCT QUALITY, WEIGHT, AND DESIRED DEGREE OF DONENESS, THE COOKING TIMES AND TEMPERATURES MAY NEED TO BE ADJUSTED ACCORDINGLY. ALWAYS FOLLOW LOCAL HEALTH (HYGIENE) REGULATIONS FOR ALL INTERNAL TEMPERATURE REQUIREMENTS.

BASIC CONTROL OPERATION

PANEL IDENTIFICATION

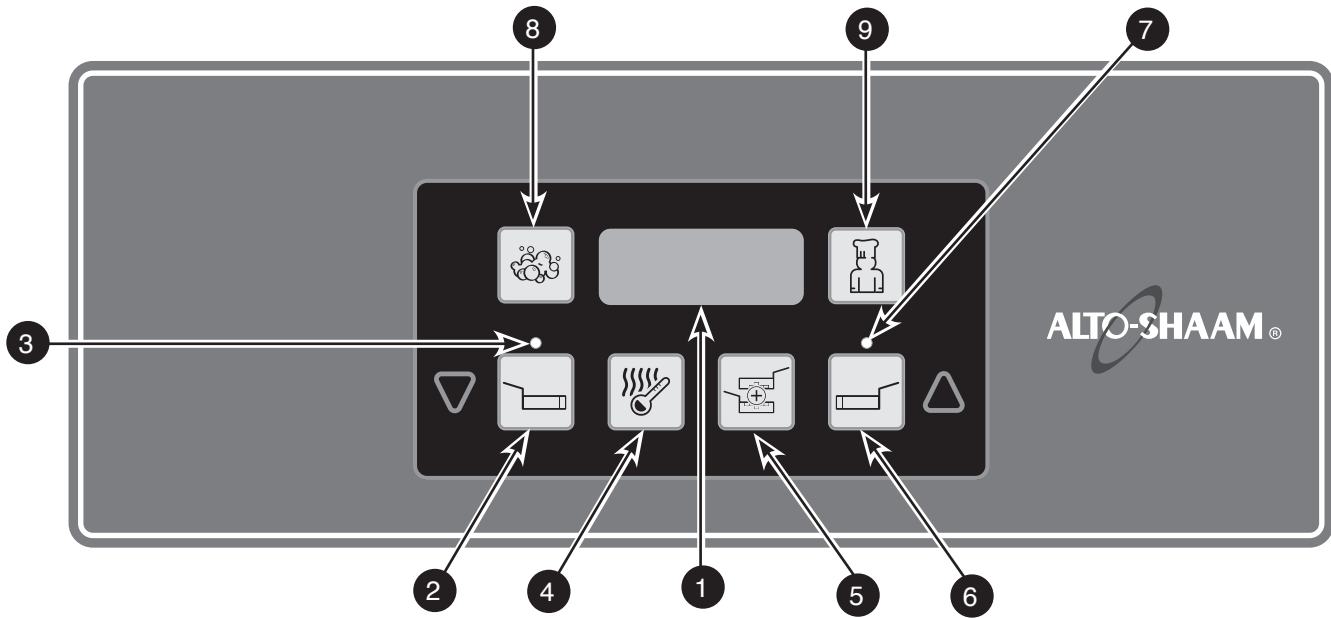

CONTROL PANEL IDENTIFICATION

1. L.E.D. 4-DIGIT DISPLAY	6. RIGHT BASKET BUTTON
2. LEFT BASKET BUTTON	7. RIGHT BASKET INDICATOR LIGHT
3. LEFT BASKET INDICATOR LIGHT	8. BOIL OUT BUTTON
4. TEMP DISPLAY BUTTON	9. PROGRAM BUTTON
5. SYNC BASKET BUTTON (Optional)	

CAUTION



METAL PARTS OF THIS EQUIPMENT BECOME EXTREMELY HOT WHEN IN OPERATION. TO AVOID BURNS, ALWAYS USE HAND PROTECTION WHEN OPERATING THIS APPLIANCE.

BASIC CONTROL OPERATION

LEFT AND RIGHT BASKET OPERATION

NOTE: Because each fryer station is controlled separately, the following procedures must be followed for every component fryer in multiple-station units.

1. Ensure that the fryer has reached the set-point temperature and it is displayed on the control panel.

(FOLLOW INSTRUCTIONS ON THE START UP AND GENERAL OPERATION PAGE)



2. **LOAD PRODUCT** Load product in basket(s) and set basket(s) in the fryer lift brackets.

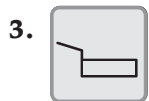

To operate the left basket, press the **LEFT BASKET** button on the control panel.

The left basket will lower.

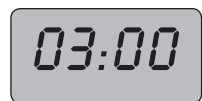

The display will show the programmed time and count down the remaining time for the left basket IF IT HAS LESS TIME LEFT THAN THE RIGHT BASKET.

During cooking, the Left Basket Indicator Light will blink fast if its time is displayed and at a slower rate if its time is not displayed.

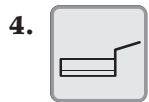

4. To operate the right basket, press the **RIGHT BASKET** button on the control panel.

The right basket will lower.

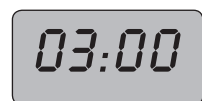

The display will show the programmed time and count down the remaining time for the right basket IF IT HAS LESS TIME LEFT THAN THE LEFT BASKET.

During cooking, the Right Basket Indicator Light will blink fast if its time is displayed and at a slower rate if its time is not displayed.

5. When the programmed time for either basket has expired:

The basket will automatically rise.

The display will show "00:00", then flash "L" or "r", and the alarm will sound on and off.

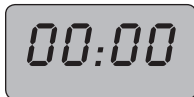

CONTINUED

BASIC CONTROL OPERATION

LEFT AND RIGHT BASKET OPERATION

6. Press the **LEFT BASKET** or **RIGHT BASKET** button to stop alarm.

7. REMOVE PRODUCT

NOTE: To stop the cooking function of either basket before the programmed time, press the **LEFT BASKET** or **RIGHT BASKET** button.

The Indicator Light for that basket will go out.

The display will revert to the other basket's remaining time or the frypot temperature.

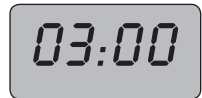

The basket will automatically rise.

SHUTDOWN

To shut the fryer station down, turn the Master Power Switch located behind the front access door to the **“OFF”** position.

The basket will automatically rise.

The display will go blank.



BASIC CONTROL OPERATION

SYNCHRONIZED BASKETS OPTION

NOTE: Because each fryer station is controlled separately, the following procedures must be followed for every component fryer in multiple-station units.

1. Ensure that the fryer has reached the set-point temperature and it is displayed on the control panel.

(FOLLOW INSTRUCTIONS ON THE START UP AND GENERAL OPERATION PAGE)



2. **LOAD PRODUCT** Load product in baskets and set baskets in the fryer lift brackets.

3.  To operate the both baskets simultaneously, press the **SYNC BASKET** button on the control panel along with either the **LEFT BASKET** or **RIGHT BASKET** button.

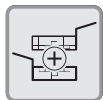

Both baskets will lower.

 The display will show the programmed time and count down the remaining time.

During cooking, the Indicator Light of the pushed button will blink fast.

4. When the programmed time has expired:

The baskets will automatically rise.

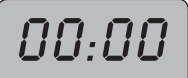
 The display will show “00:00”, then flash “L” or “r”, depending on the pushed button, and the alarm will sound on and off.

5. Press the **LEFT BASKET** or **RIGHT BASKET** button to stop alarm.

6. REMOVE PRODUCT

NOTE: Another cooking function can not be started during a synchronized cooking function.

BASIC CONTROL OPERATION

CONTROL PROGRAMMING OVERVIEW

CAUTION



THIS SECTION IS PROVIDED FOR THE ASSISTANCE OF QUALIFIED SERVICE TECHNICIANS ONLY AND IS NOT INTENDED FOR USE BY UNTRAINED OR UNAUTHORIZED SERVICE PERSONNEL.

NOTE: Because each fryer station is controlled separately, the following procedures must be followed for every component fryer in multiple-station units.

Control Programming allows you to:

- Set the left and right timers
- Choose the set-point temperature
- Choose the correct melt cycle for our frying compound
- Lock the Control Programming
- Select °F or °C for the temperature display

Press the **"PROGRAM"** button  to enter Control Programming.

 **OR**  Press the **LEFT BASKET** or **RIGHT BASKET** button to scroll through the choices for each function.

 Pressing the **PROGRAM** button confirms the change and moves on to the next function.

 **+ HOLD** Pressing and holding the **PROGRAM** button for one second exits Control Programming.

BASIC CONTROL OPERATION

PROGRAMMING THE CONTROL

CAUTION



THIS SECTION IS PROVIDED FOR THE ASSISTANCE OF QUALIFIED SERVICE TECHNICIANS ONLY AND IS NOT INTENDED FOR USE BY UNTRAINED OR UNAUTHORIZED SERVICE PERSONNEL.

NOTE: Because each fryer station is controlled separately, the following procedures must be followed for every component fryer in multiple-station units.



1. **Enter Control Programming.** Press the **PROGRAM** button.

- If unlocked, the display will go right into the Control Programming sequence.
- If locked, **“LoC”** will display, and the password routine must be pressed. (The password routine = **LEFT BASKET - LEFT BASKET - RIGHT BASKET - RIGHT BASKET.**)



2. **Set the left and right timer.** First, the Left Basket Indicator Light will come on and the currently set time for the left basket will appear in the **LED** with its colon flashing.

- Scroll up or down in one second increments by pressing  or .
- Press  to accept the new setting and proceed to the right basket timer.



Then, the Right Basket Indicator Light will come on and the currently set time for the right basket will appear in the **LED** with its colon flashing.

- Scroll up or down in one second increments by pressing  or .
- Press  to accept the new setting and go on to the set-point temperature.

3. **Choose the set-point temperature.** The current set-point temperature will appear in the **LED** with a flashing **“F”** or **“C”**.

- Scroll up or down in one degree increments by pressing  or .
- Press  to accept the new setting and proceed to offset the temperature.

4. **Calibrate (offset) the temperature.** The current offset temperature will appear in the **LED**, always in °F. The offsets available range from -20°F to 20°F.

- Scroll up or down in one degree increments by pressing  or .
- Press  to accept the new setting and proceed to the melt cycle.



BASIC CONTROL OPERATION

PROGRAMMING THE CONTROL

CAUTION



THIS SECTION IS PROVIDED FOR THE ASSISTANCE OF QUALIFIED SERVICE TECHNICIANS ONLY AND IS NOT INTENDED FOR USE BY UNTRAINED OR UNAUTHORIZED SERVICE PERSONNEL.

5. Choose the correct melt cycle for your frying compound. The melt cycle will appear in the **LED** as “**CH L**” or “**CH S**”. “**CH L**” is for liquid frying compounds such as oil and “**CH S**” is for solid frying compounds such as shortening. Do not choose “**CH 0**”.





- Scroll to change melt cycles by pressing  or .
- Press  TWICE to accept the new setting and proceed to the lock.

NOTE: Do not press just once and change the “**gAS**” or “**ELEC**” setting.

6. Lock or unlock the Control Programming. “**LoC**” or “**ULoC**” will appear in the **LED** display. “**LoC**” will prohibit unqualified personnel (without the password) from entering Control Programming. “**ULoC**” will leave Control Programming unlocked.

- Scroll to change lock condition by pressing  or .
- Press  to accept the new setting and proceed to select °F or °C.

7. Select °F or °C for the temperature display. “**F**” or “**C**” will appear in the **LED** display. “**F**” will cause the **LED** to display Fahrenheit. “**C**” will cause the **LED** to display Celsius.

- Scroll to change from °F to °C by pressing  or .
- Press  to accept the new setting and proceed to restart Control Programming sequence or press  and hold for one second to exit Control Programming.

NOTE: At any point in the sequence, pressing and holding  for one second will exit Control Programming.

BASIC CONTROL TROUBLESHOOTING

TEMPERATURE VERIFICATION

NOTE: Because each fryer station is controlled separately, the following procedures must be followed for every component fryer in multiple-station units.



The temperature of the cooking oil / shortening and the temperature set-point can be verified at any time.





Press **TEMP DISPLAY** button once to verify the actual temperature of the cooking oil / shortening.

Press **TEMP DISPLAY** button twice to verify the set-point temperature.

Press **TEMP DISPLAY** button three times to return the **LED** to its previous reading. The **LED** will also automatically return to its previous reading after three (3) seconds.

If a defective probe is suspected, measure the temperature of the oil / shortening with a thermometer. Compare the thermometer reading with the temperature shown in the control to make certain the readings are reasonably close. If there is a wide discrepancy, perform a complete fryer station shutdown and contact Alto-Shaam service.

ALARM MESSAGES

	PROBABLE CAUSE	SOLUTION
	Probe open. Probe wired wrong.	Refer to wiring diagram for correct wiring. Measure probe in ice water bath for 100 ohms resistance.
	Probe shorted. Hi-limit tripped.	Contact Alto-Shaam service. Allow frypot to cool and press the OIL HI-LIMIT RESET button for three (3) seconds.
  	Drain valve interlock.	Turn Master Power Switch off, ensure the drain is closed, and turn Master Power Switch back on.

SERVICE

1. FRYER WILL NOT POWER-UP

- A. Make certain cord is plugged in and breaker is turned “ON.”
- B. Ensure the drain switch is turned to the “CLOSED” position.
- C. Ensure the master switch is turned to the “on” position.

2. FRYER WILL NOT HEAT

- A. Ensure the gas valve is turned “ON.”
- B. Ensure the gas hose is connected.
- C. Ensure the hi-limit is not tripped.
- C. Ensure there is oil in the frypot.

3. PUMP WILL NOT RETURN OIL

- A. Ensure there is oil in the mobile oil trolley.
- B. Ensure the pump switch is turned “ON.”
- C. Push the reset button located behind the front access door to activate the pump motor.

4. BASKETS WILL NOT DROP

- A. Ensure the basket lift is programmed for basket drop.

SERVICE

CAUTION

THIS SECTION IS PROVIDED FOR THE ASSISTANCE OF QUALIFIED SERVICE TECHNICIANS ONLY AND IS NOT INTENDED FOR USE BY UNTRAINED OR UNAUTHORIZED SERVICE PERSONNEL.



DANGER



DISCONNECT UNIT FROM POWER SOURCE BEFORE CLEANING OR SERVICING.

CAUTION

IT IS RECOMMENDED THIS APPLIANCE BE INSPECTED BY A QUALIFIED SERVICE TECHNICIAN AT REGULAR INTERVALS AS PART OF A STANDARD KITCHEN MAINTENANCE PROGRAM.



EXTENDED LIMITED FRYPOT WARRANTY

Alto-Shaam, Inc. warrants to the original purchaser that any frypot that is found to be defective in material or workmanship will, at Alto-Shaam's option, subject to provisions hereinafter stated, be replaced with a new or rebuilt frypot.

The labor warranty remains in effect for three (3) years from the shipping date. Alto-Shaam will bear shipping and normal labor charges for installation performed during standard business hours, and excluding overtime, holiday rates or any additional fees.

The parts warranty remains in effect for seven (7) years from the shipping date. Following the initial three (3) year labor warranty, Alto-Shaam will replace the frypot only, with freight, labor and all additional charges at the full responsibility of the owner/operator.

Extended frypot warranty coverage is subject to all remaining provisions as set forth in Alto-Shaam's standard published warranty.

ASF-75G SERVICE

See details for these assemblies on following pages:

ITEM	PART NO	DESCRIPTION	QTY
1	5009557	230V ELECTRIC ASSY, MOTOR MOUNT	1
	CONTACT FACTORY	120V ELECTRIC ASSY, MOTOR MOUNT	1
2	5009207	230V KETTLE AND GAS TRAIN	1
	CONTACT FACTORY	120V KETTLE AND GAS TRAIN	1
3	5009210	BASIC CONTROL PANEL ASSEMBLY	1
4	5008599	DOOR	1
5	1009361	BACK ACCESS PANEL	1
6	1009002	CARRIER, MANUAL LIFT	1
7	5009558	PANEL, FRONT LOWER ASSY	1

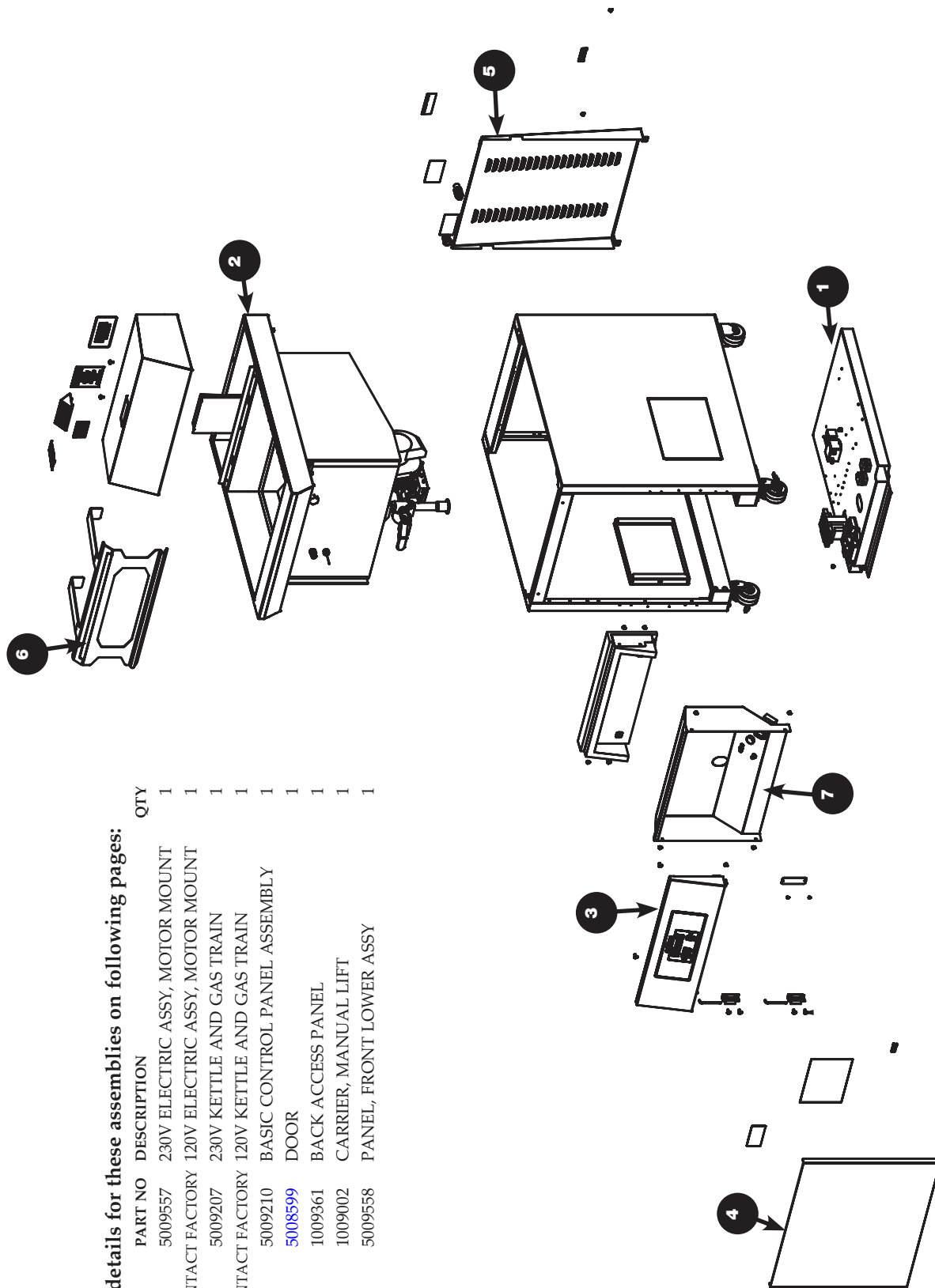

5009557

230V ELECTRIC ASSY, MOTOR MOUNT

ITEM	PART NO	DESCRIPTION	QTY
1	1009269	MOTOR PLATE	1
2	TN-34613	TRANSFORMER-50VA, 50/60HZ, CE	1
3	BK-34372	T-BLOCK, MODULAR	1
4	BK-3019	T-BLOCK	1
5	BA-34490	RELAY BOARD	1
6	FI-33406	FERRITE FILTER-CLAMP	2
7	BP-3567	BEEPER	1
8	SP-33901	SPACER, 7/16 FOR .125 HOLE IN .062" BOARD	4
9	SC-2472	SPACER, SUPPORT, NYL, 1.4"	4
10	SC-2472	SCREW,6-32 X1/2,NC PHIL TRUSS M/S,18-8 SS	2
11	FI-33225	FILTER LINE 115/250V 50/60HZ	1
12	SC-2459	8-32 X 1/4" PHIL SCREW	2
13	5004611	WIRE SET	1
14	SC-26791	SCREW 10-32 X 1/4" PAN HEAD	4
15	SC-23455	6-32 X 3/8 RD HD	2
16	HG-22672	10-32 THREADED INSERT	1
17	NU-2215	NUT,10-32,NF HEX MS,# 18-8 S/S	2
18	SC-2071	10-32 X 3/4 PAN HD	1
19	SC-2365	6-32 X 1 1/4" ROUND HD	2
20	5008200	WIRE SET ASF-75G 230V BSC	1

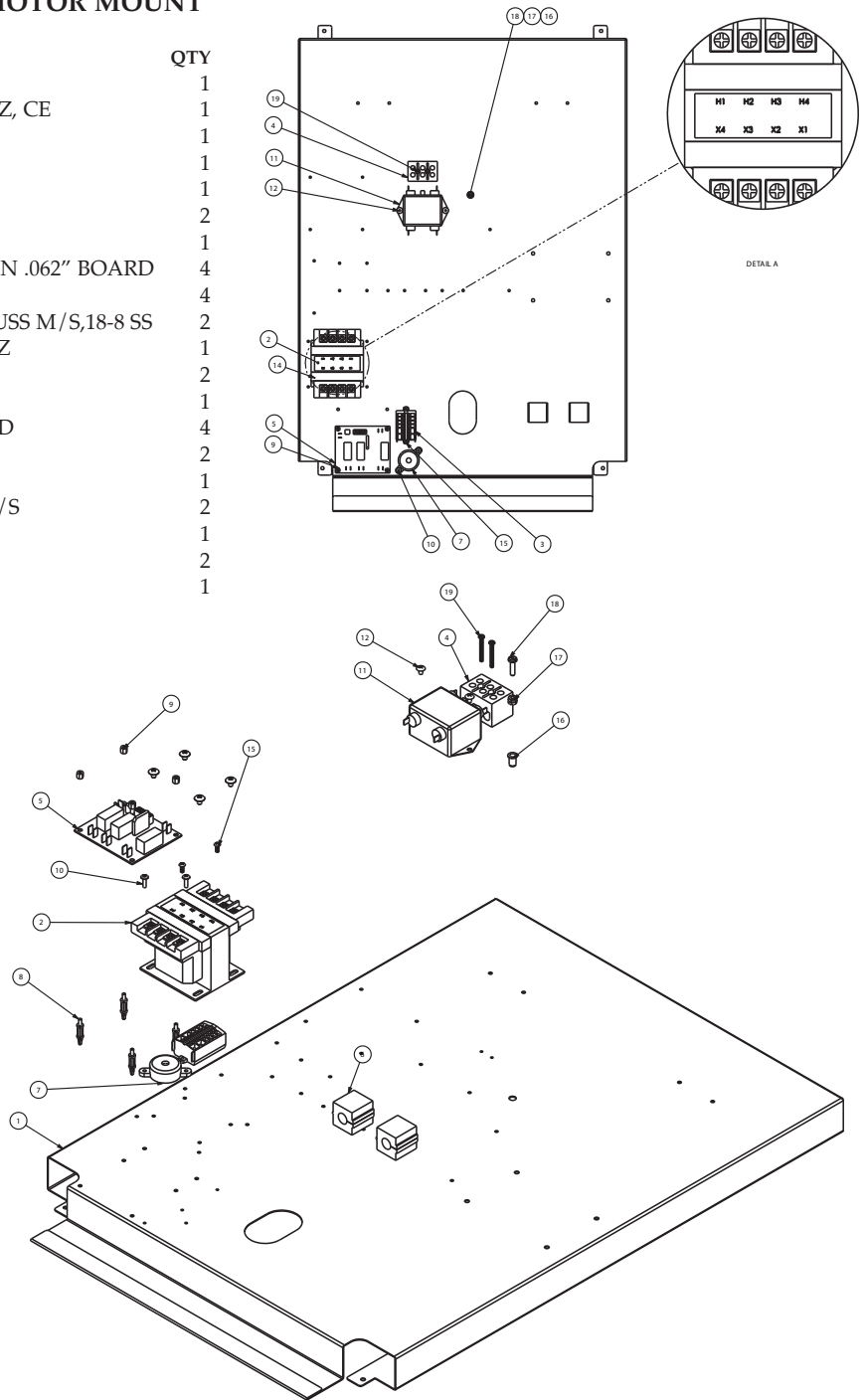

ASF-75G SERVICE

5009210 BASIC CONTROL ASSEMBLY

ITEM	PART NO	DESCRIPTION	QTY
1	5009212	WELDMENT-CONTROL PANEL, ASF-75 BSC	1
2	IN-22985	INSULATION, 1/2" CERAMIC WOOL	1
3	PE-28022	OVERLAY WITH MEMBRANE	1
4	CC-34499	CONTROL-SIMPLE	1
5	NU-2361	NUT-# 6-32	4

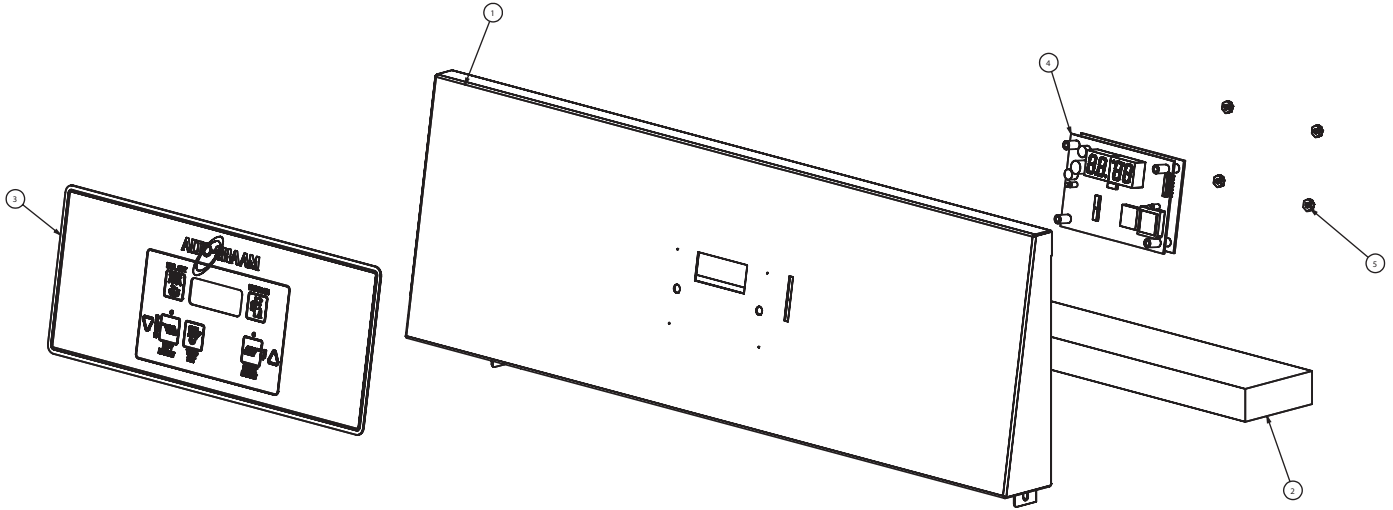

5008599 DOOR ASSEMBLY

ITEM	PART NO	DESCRIPTION	QTY
1	5009177	DOOR, ASF-75	1
2	1006303	BRACKET, MAGNET	1
3	RI-2097	#42 STAINLESS RIVET	6
4	MA-27568	MAGNET, SMCO, SILVER	1

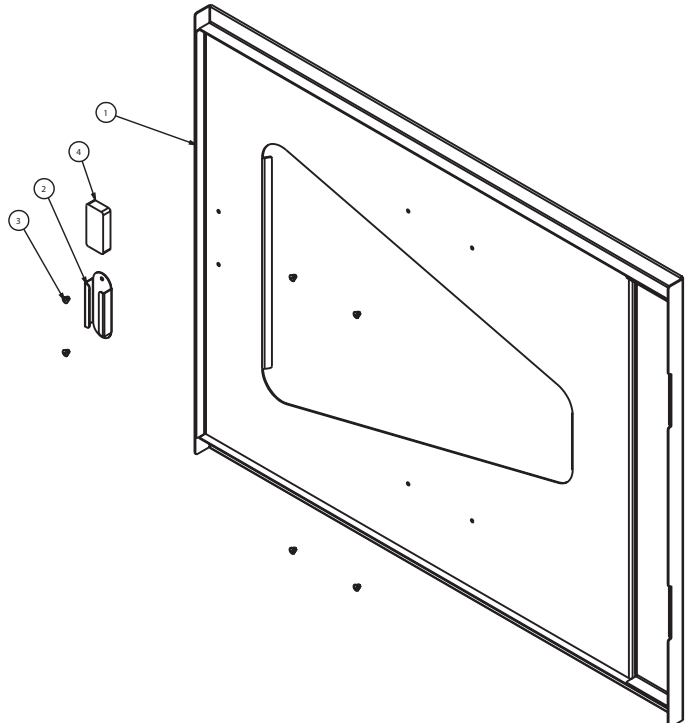

ASF-75G SERVICE

5009207

KETTLE AND GAS TRAIN

ITEM	PART NO	DESCRIPTION	QTY
1	KE-27084	FADO HRSN3, GAS	1
2	SA-27007	SEAL, SPARK PLUG	2
3	PI-27001	PIN, SPARK IGNITION	2
4	SA-27005	SEAL. SPARK PLUG	1
5	BN-34226	BURNER-HE	1
6	SA-27006	SEAL-FAN BURNER	1
7	FA-34232	FAN	1
8	VA-27068	VAVLE, VENTURI	1
9	SA-27930	SEAL, GAS VALVE	1
10	VA-34458	VALVE, 24V, FRYER, GAS 230V CE	1
11	VA-27081	ELBOW, FLANGE, VENTURI	1
12	OR-27249	O-RING, 0.812O.D. X .94 DIA	1
13	FT-27476	FITTING, 1/2" M PIPE, 1/2" M FLARE	1
14	CP-28016	CAP-3/4 NPT	1
15	GL-27004	SEAL GLASS SIGHT	1
16	GL-27002	GLASS BURNER INDICATOR	1
17	HL-27003	HOLDER GLASS SIGHT	1
18	SC-2459	8-32 X 1/4" PHIL SCREW	2
19	NU-27820	NUT HEX 6MM WITH STAR WASHER	16
20	NU-27851	NUT HEX 5MM WITH STAR WASHER	4
21	1008588	BRACKET C HIMNEY HOLDING	2
22	SC-2661	SCREW, 10-32 X 1/2, NF PHILTRUSS	2
23	5007645	FLUE	1
24	SC-27384	SC REW # 10-16 SELF DRILLING	4
25	HO-28096	HOSE-1/2ID X 24" GAS FLEXIBLE	1
26	NP-26220	NIPPLE-1/2"-14 NPT	1
27	FT-27250	FITTING 1/4" COMPRESSION X 3/8 NPT	1
28	FT-27251	FERRULE, COMPRESSION, 6MM	1
29	PR-34483	PROBE-NTC THERMISTOR 100K OHM	1
30	5008473	DRAIN ASSEMBLY	1
31	IN-27322	INSULATION, SIDE PANEL	2
32	VA-34530	VALVE GAS SAFETY, 230V	1
33	BN-34457	BURNER, CONTROL, CE CERTIFIED	1
34	CV-27825	COVER-HONEYWELL BURNER MOD	1
35	CR-34532	CONNECTOR-SAFETYGASVALVE CE	1

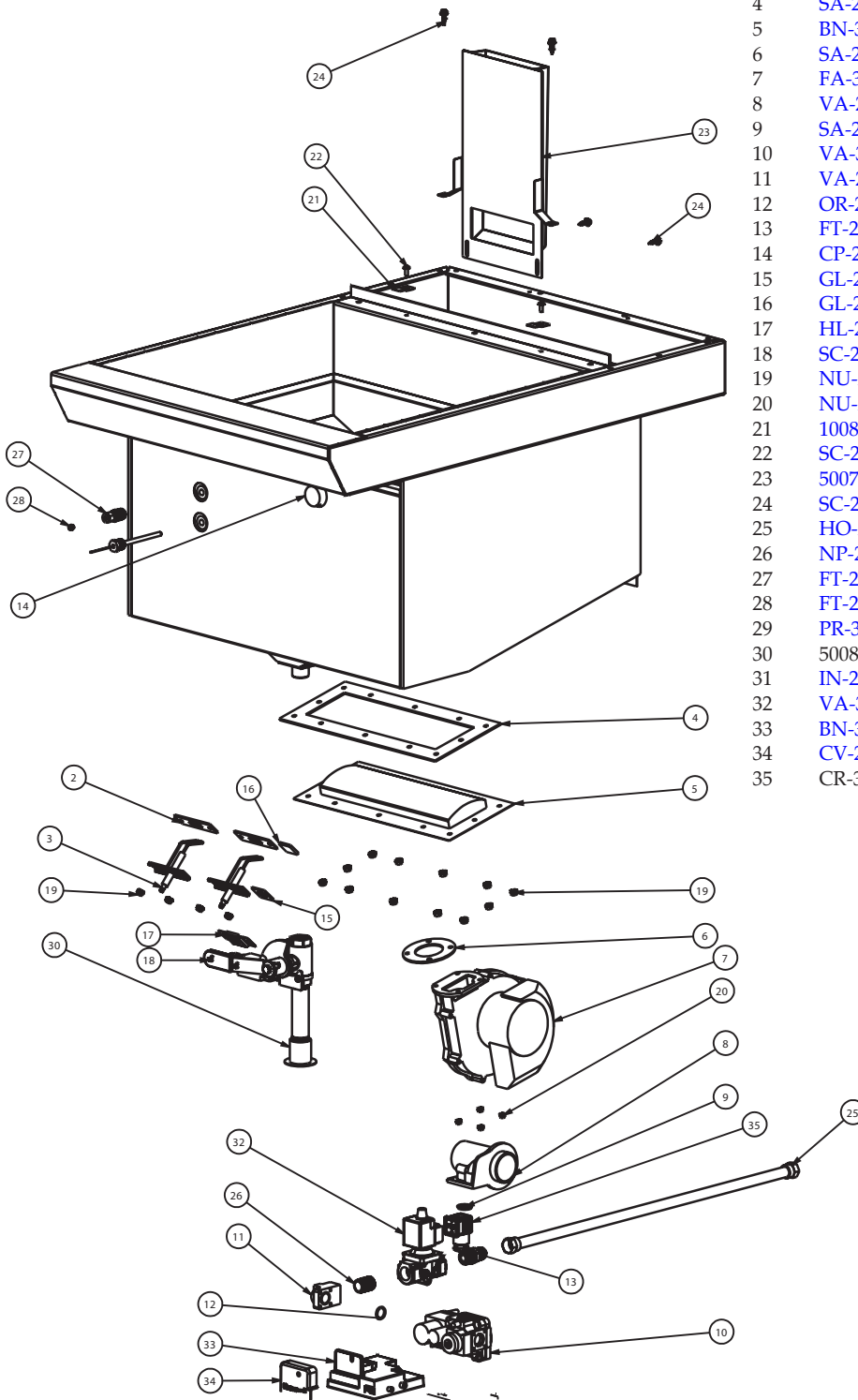

ASF-75G SERVICE

5009558

LOWER FRONT PANEL ASSY

ITEM	PART NO	DESCRIPTION	QTY
1	1010175	PANEL, FRONT LOWER ASF-75G	1
2	TT-34245	THERMOSTAT, HI-LIMIT	1
3	PA-27057	PLATE-LIGHT MOUNTING	1
4	LT-34281	LIGHT-ALARM	1
5	LT-34280	LIGHT-IGNITION ALARM	1
6	SW-34254	SWITCH, CAM, FOR SINGLE PHASE1	1
7	SC-22271	SCREWS,M4-0.7X6MM PHIL	2
8	SW-33495	SWITCH-PUSH BUTTON SPST	2

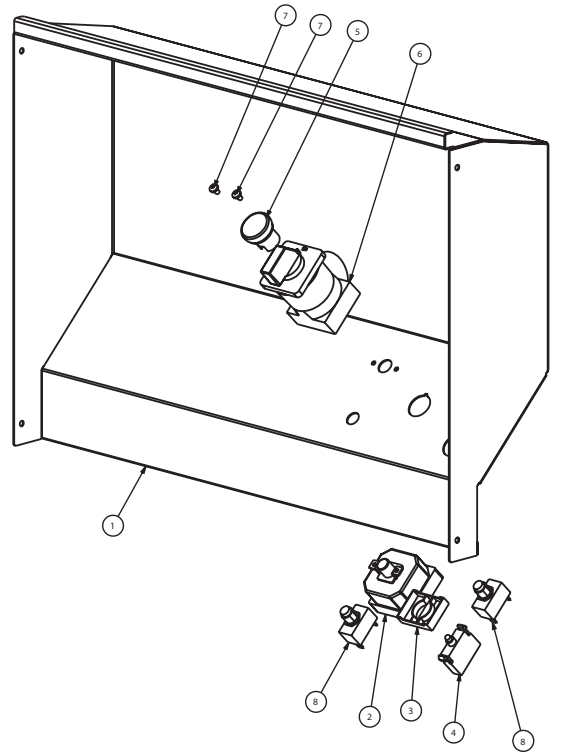
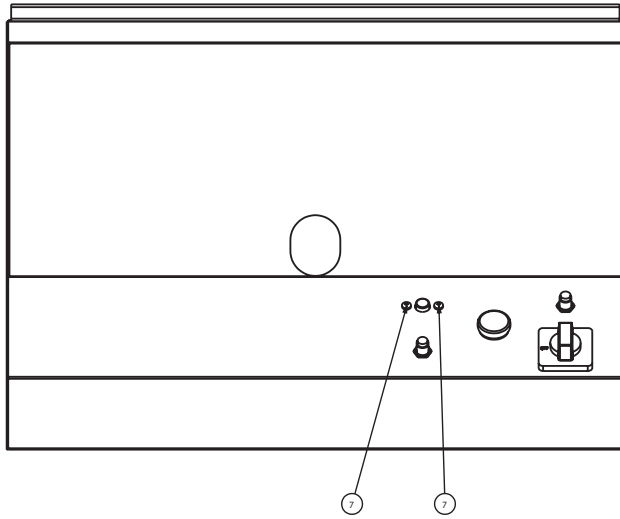

ASF-60G SERVICE

See details for these assemblies on following pages:

ITEM	PART NO	DESCRIPTION	QTY
1	5007556	ELECTRIC ASSY 120V, BASIC, LIFT	1
2	5007581	KETTLE ASSY, BASIC CONTROL	1
3	5007494	BASIC CONTROL PANEL ASSEMBLY	1
4	5007518	LIFT ASSEMBLY	1
5	5009150	DOOR	1
6	5007737	DRAIN PANEL AND SWITCHES	1
7	5008503	LOWER PANEL WITH DRAIN PIPE	1
8	5007792	VALVE-DRAIN ASSEMBLY	1
9	1008458	PANEL-BACK	1

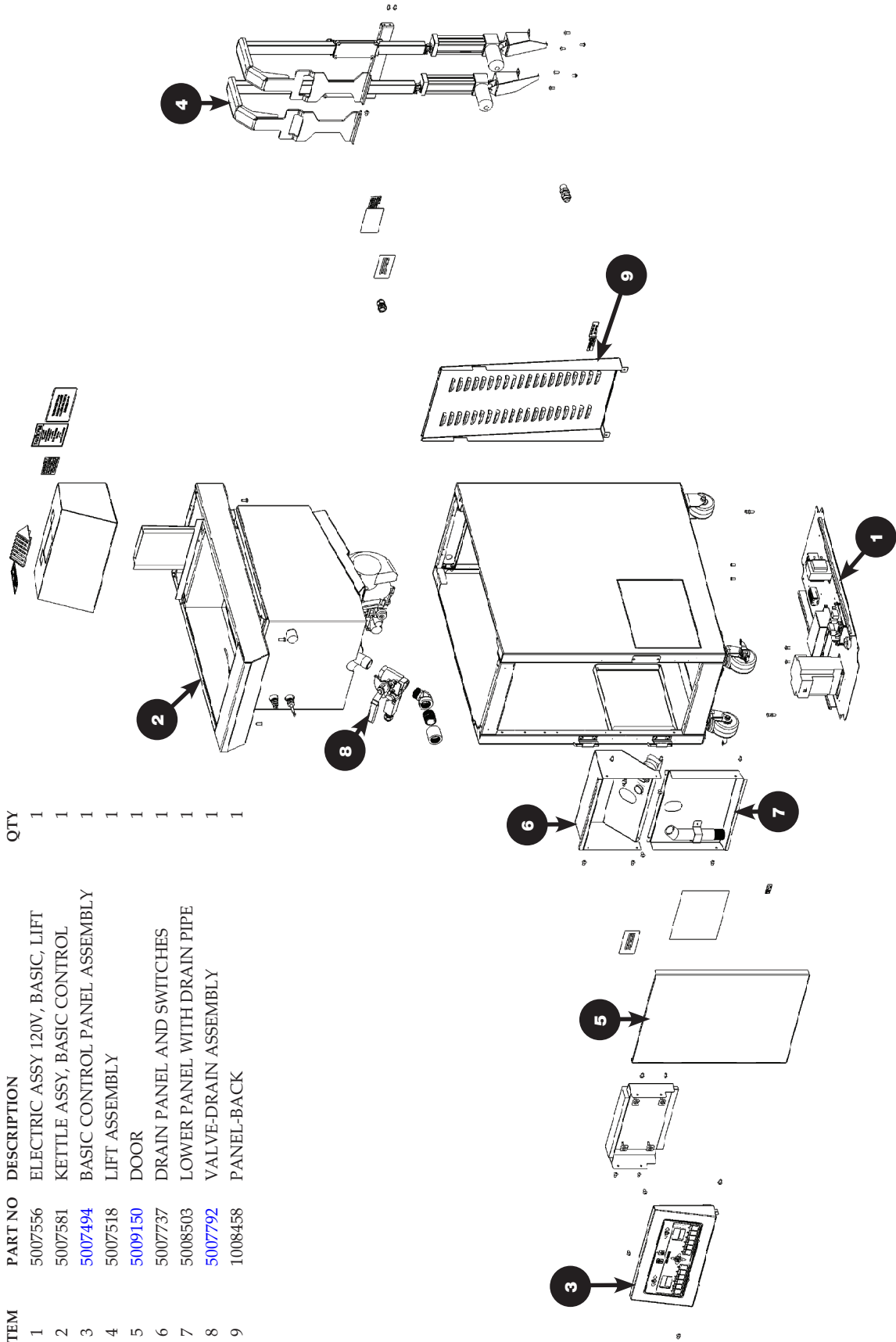

ASF-60G SERVICE

5007518 LIFT ASSEMBLY-ASF-60

ITEM	PART NO	DESCRIPTION	QTY
1	5010972	GUIDE COLUMN	2
2	1010888	GUIDE SUPPORT	2
3	RD-28118	ROD, LIFT, WELD	2
4	MO-27011	MOTOR, LIFT	2
5	1011221	GUIDE PEN	2
6	1008418	BRACKET, LIFT MOTOR MOUNT	2
7	PI-27539	PIN, 1/4" X 1 1/4", CLEVIS	4
8	PI-27540	PIN, COTTER	4
9	HL-28117	WLDMT-BASKET LIFT	2
10	SC-2661	SCREW, 10-32 X1/2,NF PHIL TRUSS M/S,18-8 SS	28
11	SC-23153	SCREW 5/16-18 X1/2 HEX TRIM HEAD	4

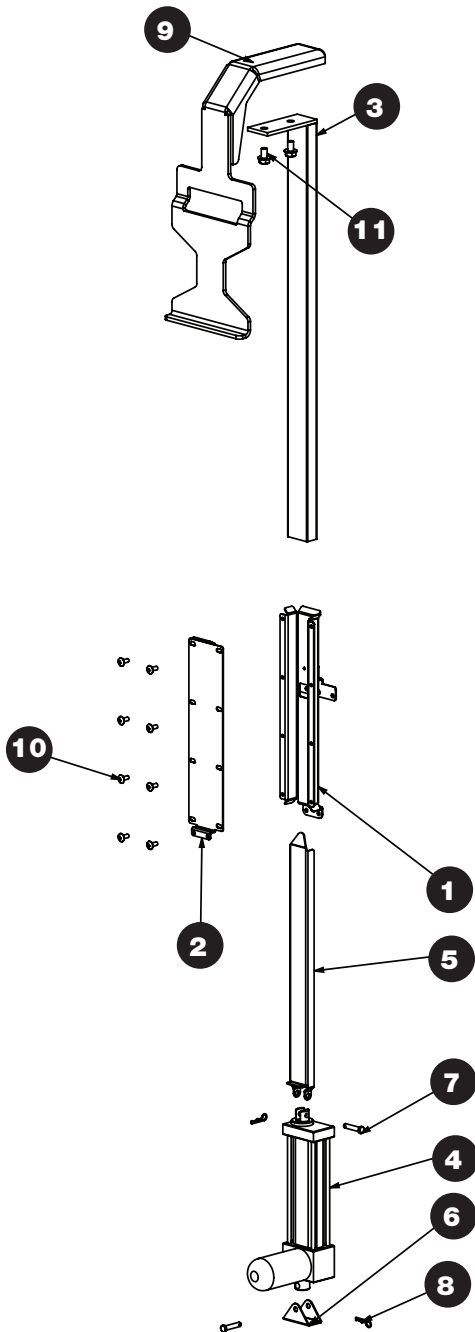

5007581 KETTLE ASSY, BASIC CONTROL

ITEM	PART NO	DESCRIPTION	QTY
1	KE-27823	KETTLE	1
2	SA-27007	SEAL-SPARK PLUG	2
3	PI-27001	PIN-SPARK IGNITION	2
4	SA-27005	SEAL-SPARK PLUG	1
5	BN-34226	BURNER-HE GAS FRYER	1
6	SA-27006	SEAL-FAN BURNER	1
7	FA-34232	FAN	1
8	VA-27068	VALVE, VETURI	1
9	SA-27930	SEAL-GAS VALVE	1
10	VA-34260	VALVE, 24V	1
11	VA-27081	ELBOW, FLANGE, VENURI	1
12	OR-27249	O-RING, 0.812 O.D. X .94 DIA	1
13	FT-27476	FITTING, 1/2" M PIPE, 1/2" M FLARE	1
14	CP-28016	CAP-3/4 NPT	1
15	GL-27004	SEAL-GLASS SIG HT	1
16	GL-27002	GLASS BURNER INDICATOR	1
17	HL-27003	HOLDER- GLASS SIG HT	1
18	SC-2459	8-32 X 1/4" PHIL SCREW	2
19	NU-27820	NUT-HEX 6MM WITH STAR WASHER	16
20	NU-27851	NUT-HEX 5MM WITH STAR WASHER	4
21	1008588	BRACKET-CHIMNEY HOLDING	2
22	SC-2661	SCREW, 10-32 X 1/2, NF PHIL	2
23	5007645	FLUE	1
24	SC-27384	SCREW-# 10-16 SELF DRILLING	4
25	HO-28096	HOSE-1/2 ID X 24" GAS FLEXIBLE	1
26	VA-34531	VALVE-SAFETY 24VAC 1/2 NPT	1
27	NP-26220	NIPPLE-1/2"-14 NPT	1
28	FT-27250	FITTING - 1/4" COMPRESSION	1
29	FT-27251	FERRULE, COMPRESSION 6MM	1
30	PR-34483	PROBE-NTC THERMISTOR	1

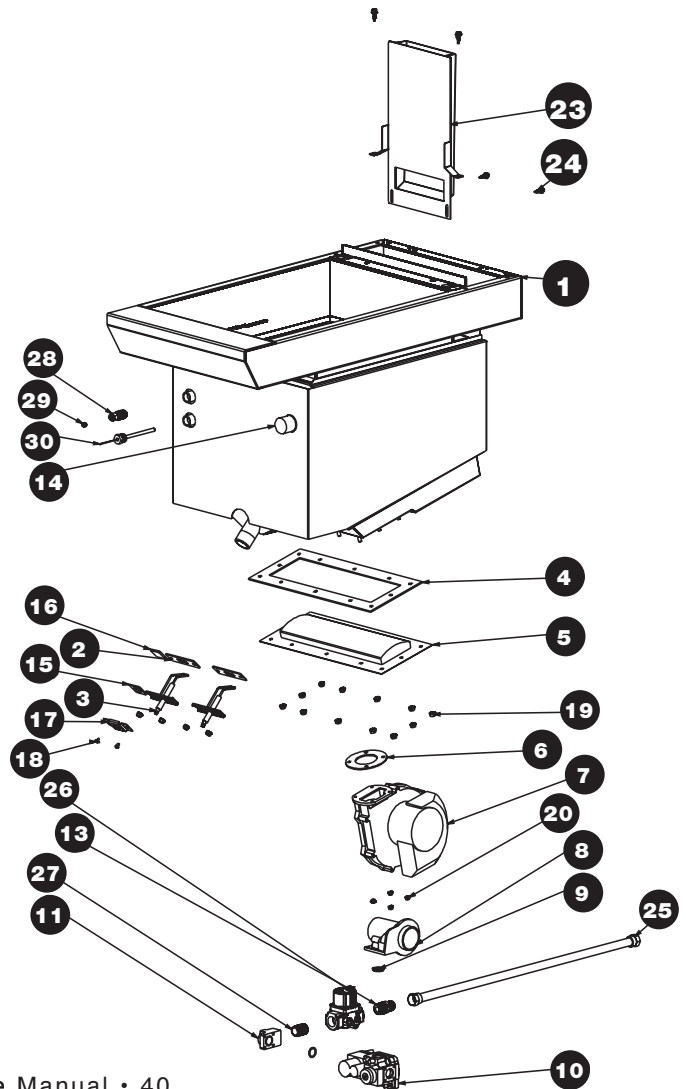

5009150 DOOR

ITEM	PART NO	DESCRIPTION	QTY
1	5007555	WLDMT-DOOR	1
2	1006303	MAGNET BRACKET	1
3	RI-2097	#42 STAINLESS RIVET	6
4	MA-25734	MAGENT, DOOR	1

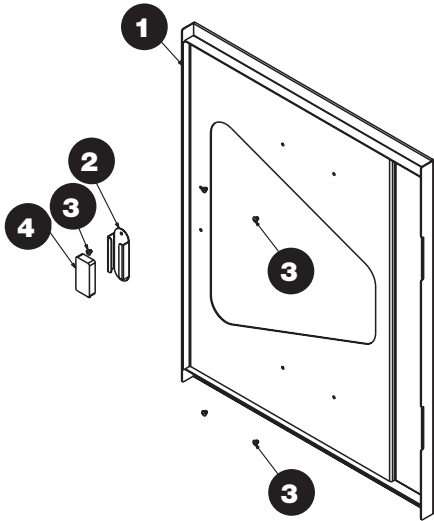

5007737 DRAIN PANEL & SWITCHES

ITEM	PART NO	DESCRIPTION	QTY
1	1009234	PANEL, FRONT LOWER	1
2	TT-34245	THERMOSTAT, HI-LIMIT	1
3	PA-27057	PLATE-LIGHT MOUNTING	1
4	LT-34281	LIGHT-ALARM	1
5	LT-34280	LIGHT-IGNITION ALARM	1
6	SW-34254	SWITCH, CAM, FOR SINGLE PHASE	1
7	PG-3344	1/2" HOLE PLUG	1
8	SC-22271	SCREWS,M4-0.7X6MM PHIL	2
9	SW-33495	SWITCH-PUSH BUTTON SPST	1

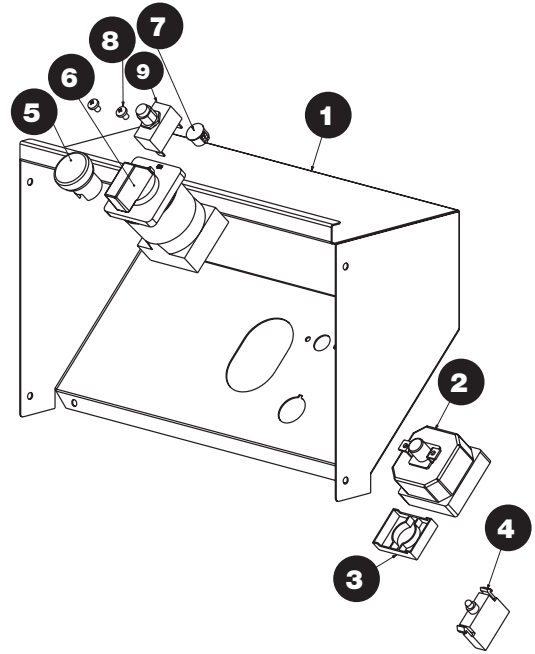

5007792 VALVE-DRAIN ASSEMBLY

ITEM	PART NO	DESCRIPTION	QTY
1	VA-28114	VALVE-BALL USE WITH FT-28113	1
2	5008497	WLDMT-DRAIN CAM	1
3	1008739	BRACKET, DRAIN SWITCH MOUNT	1
4	SW-34246	LIMIT SWITCH	1
5	SC -28288	SCREW-10-24 x .375 PHMS	2
6	BU-3964	BUSHING, STRAIG HT, STRAIN RELIEF	1
7	WS-23671	WASHER, LOCK, #10, 18-8 S/S	2
8	SC -2069	SCREW, 8-32 X 1, NC PHILLIPS PAN	2

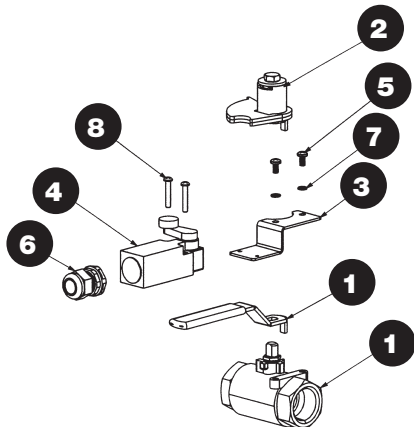

5008503 LOWER PANEL WITH DRAIN PIPE

ITEM	PART NO	DESCRIPTION	QTY
1	1009173	PANEL, LOWER	1
2	1009174	BRACKET-DRAIN HOLDER	1
3	RI-2097	#42 STAINLESS RIVET	2
4	PP-28126	PIPE - DRAIN	1

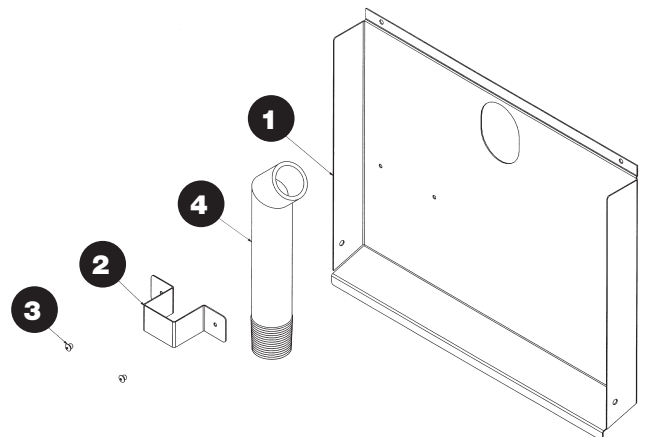

ASF-60G SERVICE

5007494 BASIC CONTROL PANEL ASSEMBLY

ITEM	PART NO	DESCRIPTION	QTY
1	5007565	WLDMT, BASIC CONTROL PANEL	1
2	CC-34499	BASIC CONTROL	1
3	PE-27929	BASIC PANEL OVERLAY	1
4	NU-2361	NUT, 6-32 HEX, S/S	4

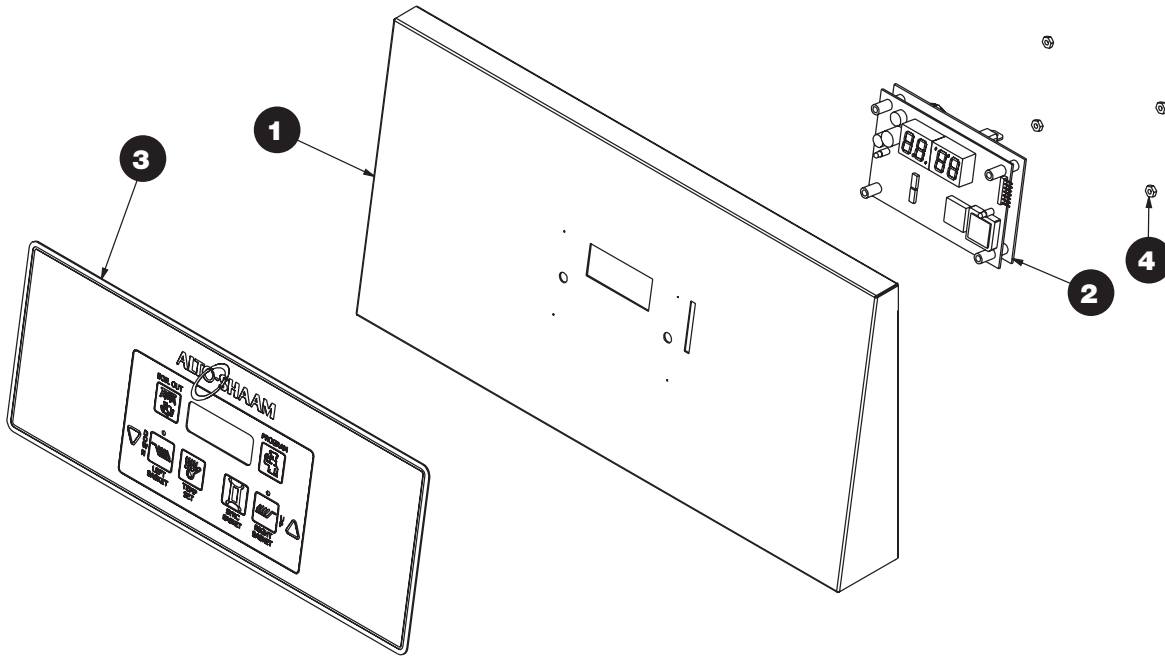

ASF-75G SERVICE

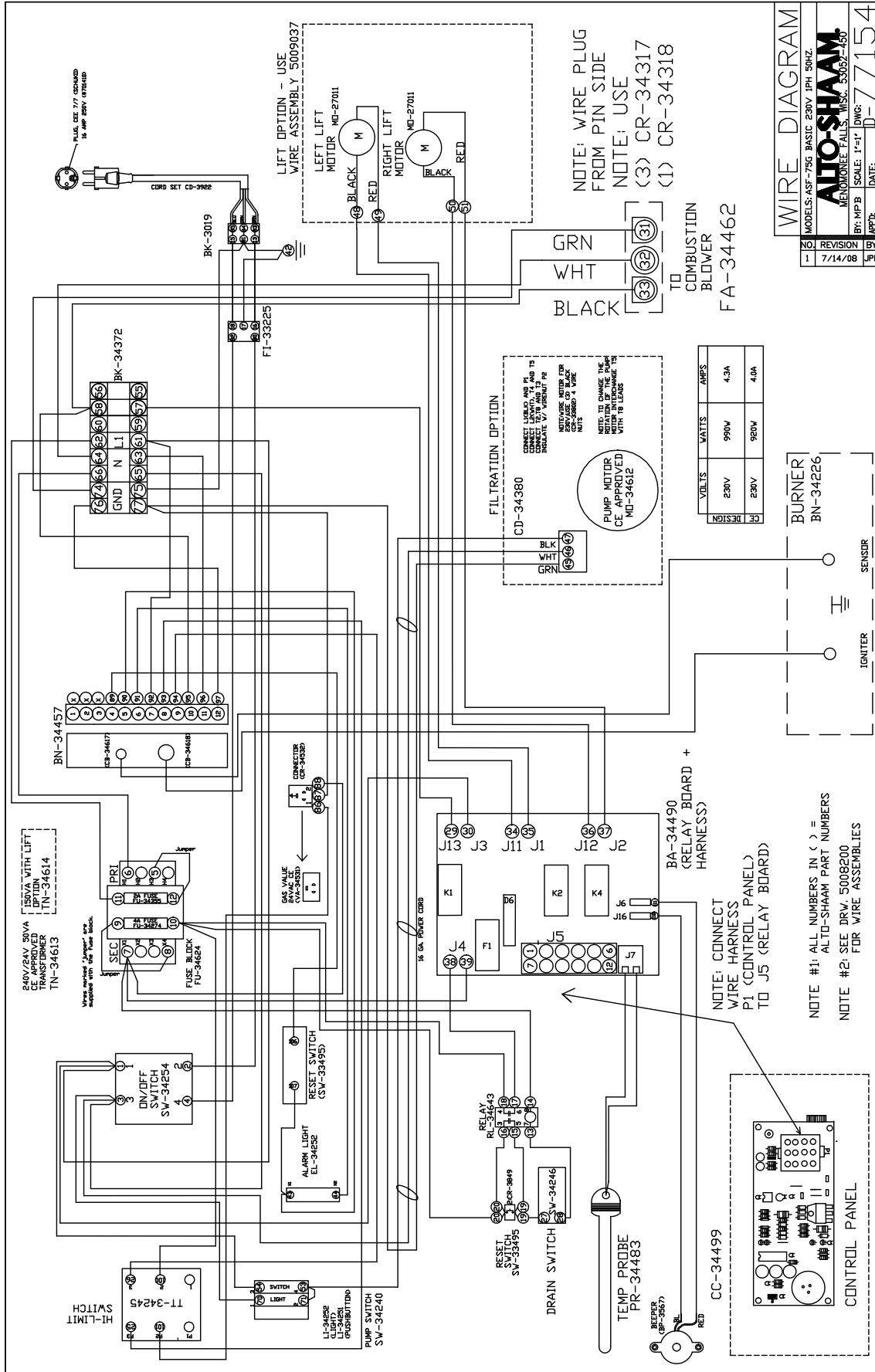

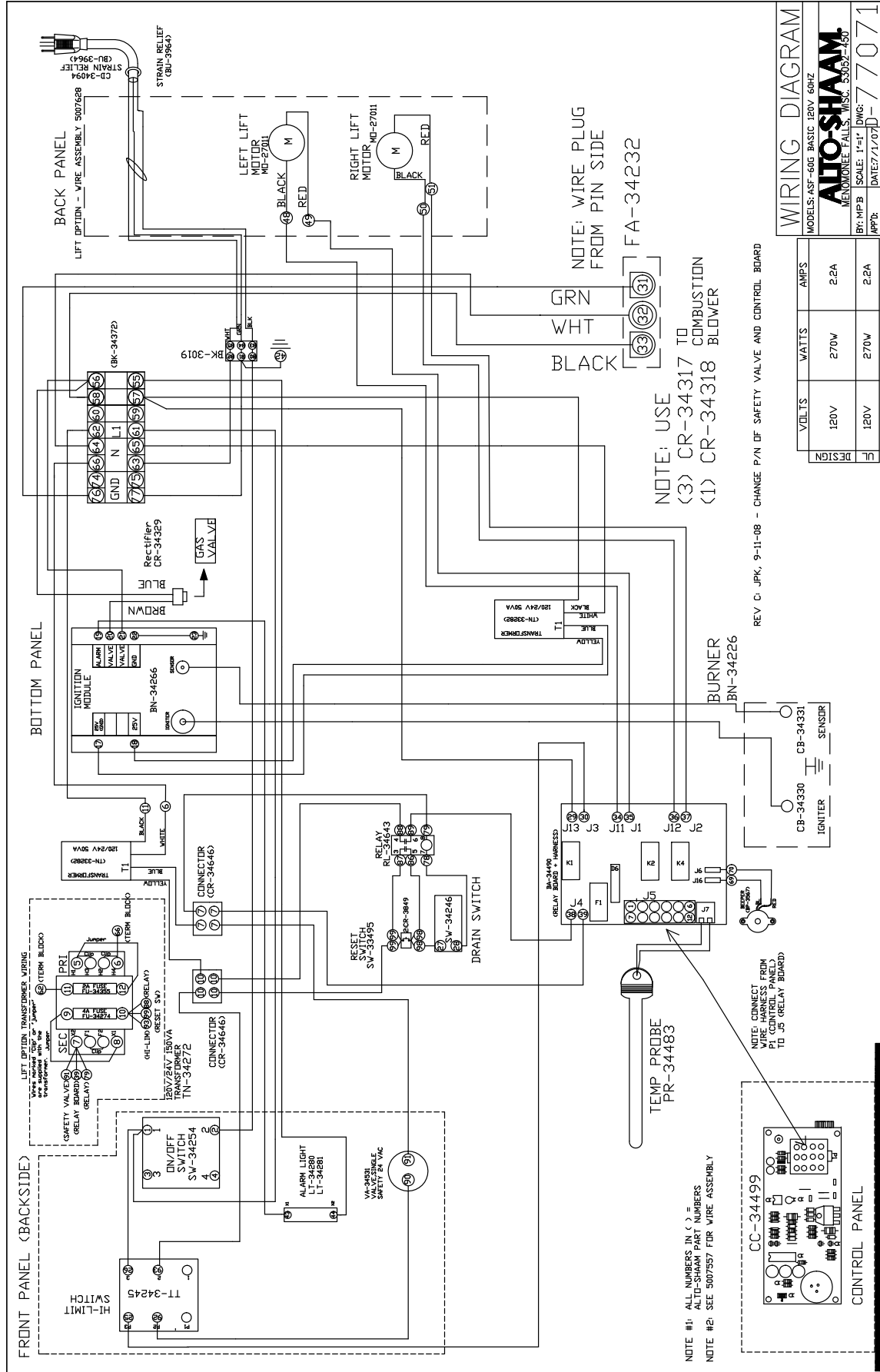

TRANSPORTATION DAMAGE and CLAIMS



All Alto-Shaam equipment is sold F.O.B. shipping point, and when accepted by the carrier, such shipments become the property of the consignee.

Should damage occur in shipment, it is a matter between the carrier and the consignee. In such cases, the carrier is assumed to be responsible for the safe delivery of the merchandise, unless negligence can be established on the part of the shipper.

1. Make an immediate inspection while the equipment is still in the truck or immediately after it is moved to the receiving area. Do not wait until after the material is moved to a storage area.
2. Do not sign a delivery receipt or a freight bill until you have made a proper count and inspection of all merchandise received.
3. Note all damage to packages directly on the carrier's delivery receipt.
4. Make certain the driver signs this receipt. If he refuses to sign, make a notation of this refusal on the receipt.
5. If the driver refuses to allow inspection, write the following on the delivery receipt:
Driver refuses to allow inspection of containers for visible damage.
6. Telephone the carrier's office immediately upon finding damage, and request an inspection. Mail a written confirmation of the time, date, and the person called.
7. Save any packages and packing material for further inspection by the carrier.
8. Promptly file a written claim with the carrier and attach copies of all supporting paperwork.

We will continue our policy of assisting our customers in collecting claims which have been properly filed and actively pursued. We cannot, however, file any damage claims for you, assume the responsibility of any claims, or accept deductions in payment for such claims.

LIMITED WARRANTY

Alto-Shaam, Inc. warrants to the original purchaser only that any original part that is found to be defective in material or workmanship will, at Alto-Shaam's option, subject to provisions hereinafter stated, be replaced with a new or rebuilt part.

The parts warranty period is as follows:

For the refrigeration compressor on Alto-Shaam Quickchillers™, five (5) years from the date of installation.

For the heating element on Halo Heat® cook/hold ovens, as long as the original purchaser owns the oven.

For all other parts, one (1) year from the date of installation or fifteen (15) months from the shipping date, whichever occurs first.

The labor warranty period is one (1) year from the date of installation or fifteen (15) months from the shipping date, whichever occurs first.

Alto-Shaam will bear normal labor charges performed during standard business hours, excluding overtime, holiday rates or any additional fees.

To be valid, a warranty claim must be asserted during the applicable warranty period. This warranty is not transferable.

THIS WARRANTY DOES NOT APPLY TO:

1. Calibration.
2. Replacement of light bulbs, door gaskets, and/or the replacement of glass due to damage of any kind.
3. Equipment damage caused by accident, shipping, improper installation or alteration.
4. Equipment used under conditions of abuse, misuse, carelessness or abnormal conditions, including but not limited to, equipment subjected to harsh or inappropriate chemicals, including but not limited to, compounds containing chloride or quaternary salts, poor water quality, or equipment with missing or altered serial numbers.
5. Damage incurred as a direct result of poor water quality, inadequate maintenance of steam generators and/or surfaces affected by water quality. Water quality and required maintenance of steam generating equipment is the responsibility of the owner/operator.
6. Damage caused by use of any cleaning agent other than Alto-Shaam's Combitherm® Cleaner, including but not limited to damage due to chlorine or other harmful chemicals. **Use of Alto-Shaam's Combitherm® Cleaner on Combitherm® ovens is highly recommended.**
7. Any losses or damage resulting from malfunction, including loss of product or consequential or incidental damages of any kind.
8. Equipment modified in any manner from original model, substitution of parts other than factory authorized parts, removal of any parts including legs, or addition of any parts.

This warranty is exclusive and is in lieu of all other warranties, express or implied, including the implied warranties of merchantability and fitness for a particular purpose. In no event shall Alto-Shaam be liable for loss of use, loss of revenue or profit, or loss of product, or for any indirect, special, incidental, or consequential damages. No person except an officer of Alto-Shaam, Inc. is authorized to modify this warranty or to incur on behalf of Alto-Shaam any other obligation or liability in connection with Alto-Shaam equipment.

Effective 09/10



RECORD THE MODEL AND SERIAL NUMBER OF THE APPLIANCE FOR EASY REFERENCE.
ALWAYS REFER TO BOTH MODEL AND SERIAL NUMBER IN ANY CONTACT WITH ALTO-SHAAM REGARDING THIS APPLIANCE.

Model: _____ Date Installed: _____
Voltage: _____ Purchased From: _____
Serial Number: _____

W164 N9221 Water Street • P.O. Box 450 • Menomonee Falls, Wisconsin 53052-0450 • U.S.A.

PHONE: 262.251.3800 • 800.558-8744 USA/CANADA FAX: 262.251.7067 • 800.329.8744 U.S.A. ONLY

www.alto-shaam.com

PRINTED IN U.S.A.