

ALTO-SHAAM®

GAS FRYER
FryTech Series

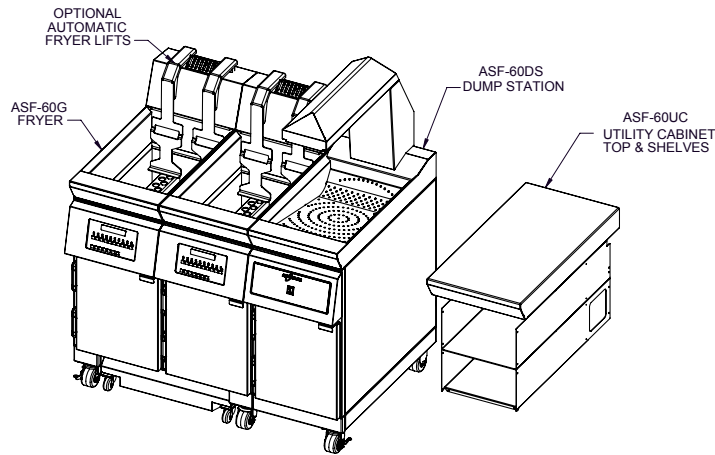

SAMPLE CONFIGURATION SHOWN

ASF-60B
Gas Fryer
Battery

- **INSTALLATION**
- **OPERATION**
- **MAINTENANCE**



W164 N9221 Water Street • P.O. Box 450 • Menomonee Falls, Wisconsin 53052-0450 USA
PHONE: 262.251.3800 • 800.558.8744 USA/CANADA FAX: 262.251.7067 • 800.329.8744 U.S.A. ONLY
www.alto-shaam.com

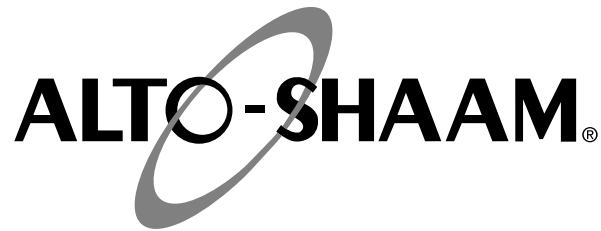

Delivery 1
Unpacking 1
Safety Procedures and Precautions 2

Installation

Dimension Drawings, Weights & Capacities 3
Clearance Requirements 4
Site Installation & Leveling 5
Ventilation 6
Gas Specifications 7
Gas Connection 8
Restraint Requirements - Mobile Equipment 9
Electrical Requirements 10

Operation

Oil/Shortening Requirements 11
Controls Behind Access Panel 12
Panel Identification 13
Cook Cycle 14
Holding Timers 14
Product Count 15
Display Descriptions 15
Product Key Programming 16
System Programming 19
Programming Custom Product & Action Alarms 20
Suggested Frying Times 21

Cleaning

Daily Cleaning & Maintenance 23
Boil-Out Instructions 24

Service

Control Troubleshooting 26
Unit Troubleshooting 26
Extended Limited Frypot Warranty 27
ASF-60G Service Views 28

Wire Diagrams

Always refer to the wire diagram(s) included with the unit for most current version.

Warranty

Transportation Damage and Claims Back Cover
Limited Warranty Back Cover

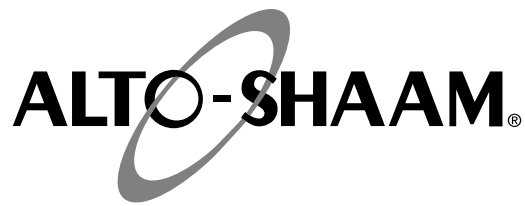

DELIVERY

This Alto-Shaam appliance has been thoroughly tested and inspected to ensure only the highest quality unit is provided. Upon receipt, check for any possible shipping damage and report it at once to the delivering carrier. *See Transportation Damage and Claims section located in this manual.*

This appliance, complete with unattached items and accessories, may have been delivered in one or more packages. Check to ensure that all standard items and options have been received with each model as ordered.

Save all the information and instructions packed with the appliance. Complete and return the warranty card to the factory as soon as possible to ensure prompt service in the event of a warranty parts and labor claim.

This manual must be read and understood by all people using or installing the equipment model. Contact the Alto-Shaam Tech Team Service Department if you have any questions concerning installation, operation, or maintenance.

NOTE: All claims for warranty must include the full model number and serial number of the unit.

UNPACKING

1. Carefully remove the appliance from the carton or crate.

NOTE: Do not discard the carton and other packaging material until you have inspected the unit for hidden damage and tested it for proper operation.

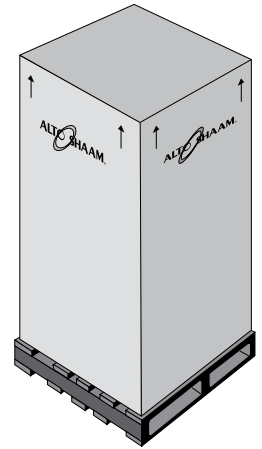

2. Read all instructions in this manual carefully before initiating the installation of this appliance.

DO NOT DISCARD THIS MANUAL.

This manual is considered to be part of the appliance and is to be provided to the owner or manager of the business or to the person responsible for training operators. *Additional manuals are available from the Alto-Shaam Tech Team Service Department.*

3. Remove all protective plastic film, packaging materials, and accessories from the appliance before connecting electrical power. Store any accessories in a convenient place for future use.

DANGER



BEFORE STARTING THE APPLIANCE, MAKE CERTAIN YOU DO NOT DETECT THE ODOR OF GAS.

IF THE ODOR OF GAS IS DETECTED:

- DO NOT attempt to light any appliance.
- DO NOT touch any electrical switches.
- Extinguish any open flame.
- Use a telephone **OUTSIDE THE PROPERTY & IMMEDIATELY** contact your gas supplier.
- If unable to contact your gas supplier, contact the fire department.

WARNING



In the event of loss of power to the appliance, turn the "burner control knobs" to the OFF position. Remove food product from the unit. If burner control fails to extinguish the flame, shut off main gas valve located in rear of unit.

KEEP THIS MANUAL IN A CONVENIENT LOCATION FOR REFERENCE.

INSTALLATION

SAFETY PROCEDURES AND PRECAUTIONS

Knowledge of proper procedures is essential to the safe operation of electrically and/or gas energized equipment. In accordance with generally accepted product safety labeling guidelines for potential hazards, the following signal words and symbols may be used throughout this manual.

DANGER



Used to indicate the presence of a hazard that **WILL** cause severe personal injury, death, or substantial property damage if the warning included with this symbol is ignored.

WARNING



Used to indicate the presence of a hazard that **CAN** cause personal injury, possible death, or major property damage if the warning included with this symbol is ignored.

CAUTION



Used to indicate the presence of a hazard that can or will cause minor or moderate personal injury or property damage if the warning included with this symbol is ignored.

CAUTION

Used to indicate the presence of a hazard that can or will cause minor personal injury, property damage, or a potential unsafe practice if the warning included with this symbol is ignored.

NOTE: Used to notify personnel of installation, operation, or maintenance information that is important but not hazard related.

1. This appliance is intended to cook, hold or process foods for the purpose of human consumption. No other use for this appliance is authorized or recommended.
2. This appliance is intended for use in commercial establishments where all operators are familiar with the purpose, limitations, and associated hazards of this appliance. Operating instructions and warnings must be read and understood by all operators and users.
3. Any troubleshooting guides, component views, and parts lists included in this manual are for general reference only and are intended for use by qualified technical personnel.
4. This manual should be considered a permanent part of this appliance. This manual and all supplied instructions, diagrams, schematics, parts lists, notices, and labels must remain with the appliance if the item is sold or moved to another location.

NOTE

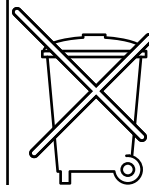

For equipment delivered for use in any location regulated by the following directive:

DO NOT DISPOSE OF ELECTRICAL OR ELECTRONIC EQUIPMENT WITH OTHER MUNICIPAL WASTE.

INSTALLATION

ASF-60B GAS SPECIFICATIONS

The Alto-Shaam fryer/dump station batteries combine up to four (4) ASF-60 fryers, dump station and/or utility cabinet in one frame. The battery also includes an oil filtration system. The battery is constructed of stainless steel and features front- and rear-mounted, heavy duty leveling casters. Two fry baskets and a cleaning brush set are included with each fryer. The fryers have a temperature range of 200°F to 400°F (93°C to 205°C). The ASF-60DS dump station features an overhead infrared heating element that is controlled with one (1) ON/OFF power switch. The dump station holding well includes a removable screen grid insert to collect crumbs and small bits of product in a removable 11" x 14" x 4" (279 x 356 x 120mm) catch pan located behind the door.

STANDARD ACCESSORIES	
<input type="checkbox"/> Basket, Half-Size (2 INCLUDED AS STANDARD)	BS-35214
Brush Set (ONE 2-BRUSH SET INCLUDED AS STANDARD)	
<input type="checkbox"/> SCRUB BRUSH	BH-28693
<input type="checkbox"/> STRAIGHT BRUSH	BH-28691

CAPACITY PER FRYPOT	
SHORTENING/OIL: 62 lb (28 kg) MAXIMUM	
LOAD CAPACITY: 8 lb (4 kg) MAXIMUM	

WEIGHT PER FRYPOT EST		
	NET WEIGHT	SHIP WEIGHT
WITHOUT LIFTS	248 lb (113 kg)	330 lb (150 kg)
WITH LIFTS	265 lb (120 kg)	347 lb (157 kg)
CARTON DIMENSIONS (L x W x H)		CONTACT FACTORY

OPTIONS	
Filters	
<input type="checkbox"/> Paper, 7 count refill package	FI-27791
<input type="checkbox"/> Paper, 100 count refill package	FI-27794
<input type="checkbox"/> Charcoal/Carbon, 30 count package	FI-27648
<input type="checkbox"/> Reusable Mesh, single filter	FI-27014
<input type="checkbox"/> Frypot Cover	CONTACT FACTORY
<input type="checkbox"/> Mobile Drawer Cover	5006073
<input type="checkbox"/> Mobile Oil Caddy (WITH OIL DISCARD HOSE)	TO-28359
<input type="checkbox"/> Oil Discard Hose	HO-28812
<input type="checkbox"/> Pre-Filter Sieve Kit	5010451
<input type="checkbox"/> Strainer/Skimmer	CE-27400



Battery combinations are customer specific. Batteries are ordered and labeled from left to right.

ASF-60B = battery appliance.
The next characters will indicate equipment piece.

1G = 1 gas fryer;

2G = 2 gas fryers;

3G = 3 gas fryers;

4G = 4 gas fryers

1DS = 1 dump station;

1UC = 1 utility cabinet.

ASF-60B, 2G, 1DS, 1G would mean that the battery includes 2 gas fryers on the farthest left side, then one dump station, followed by another gas fryer.

The sample illustration at right would be labeled as:
ASF-60B, 2G, 1DS

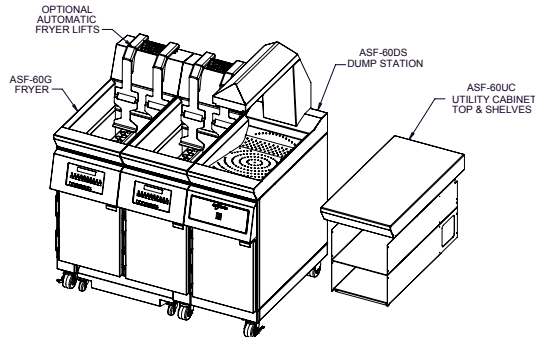
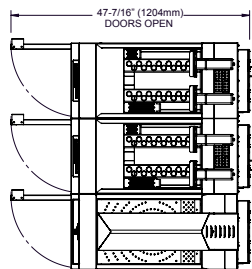

STATIONS	OVERALL WIDTH
2	30" (762mm)
3	45" (1143mm)
4	60" (1524mm)

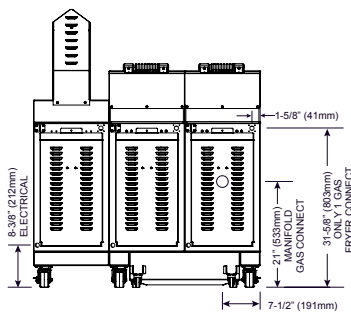
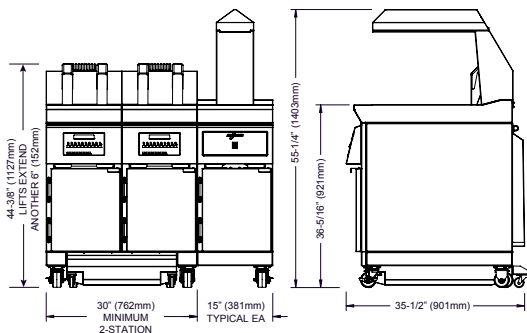

INSTALLATION

DANGER



IMPROPER INSTALLATION, ALTERATION, ADJUSTMENT, SERVICE, OR MAINTENANCE COULD RESULT IN SEVERE INJURY, DEATH, OR CAUSE PROPERTY DAMAGE.

READ THE INSTALLATION, OPERATING AND MAINTENANCE INSTRUCTIONS THOROUGHLY BEFORE INSTALLING OR SERVICING THIS EQUIPMENT.

DANGER



AVERTISSEMENT : UNE INSTALLATION, UN AJUSTEMENT, UNE ALTÉRATION, UN SERVICE OU UN ENTRETIEN NON CONFORME AUX NORMES PEUT CAUSER DES DOMMAGES À LA PROPRIÉTÉ, DES BLESSURES OU LA MORT.

LIRE ATTENTIVEMENT LES DIRECTIVES D'OPÉRATION ET D'ENTRETIEN AVANT DE FAIRE L'INSTALLATION, OU L'ENTRETIEN DE CET ÉQUIPEMENT.

CAUTION



METAL PARTS OF THIS EQUIPMENT BECOME EXTREMELY HOT WHEN IN OPERATION. TO AVOID BURNS, ALWAYS USE HAND PROTECTION WHEN OPERATING THIS APPLIANCE.

SITE INSTALLATION

MINIMUM CLEARANCE REQUIREMENTS

	COMBUSTIBLE SURFACES	NON-COMBUSTIBLE SURFACES
RIGHT SIDE	6" (152mm)	0" (0mm)
LEFT SIDE	6" (152mm)	0" (0mm)
BACK	6" (152mm)	
FRONT	25" (635mm)	

PLUS: 6" (152mm) minimum between the element swing in the extended position and the lower edge of the exhaust hood and filter media.

ENTRY CLEARANCE: 60" (1524mm)

4 UNIT MAXIMUM WIDTH UNCRATED

Ne pas installer à une distance inférieure à celle indiquée ce-dessous d'une paroi en matière combustible: Côtés 6 pouces, Arrière 6 pouces.

WARNING

MINIMUM CLEARANCES MUST REMAIN UNOBSTRUCTED.

DO NOT place insulation or any other type of materials in clearance areas.

CAUTION

DO NOT USE FORKLIFT FROM FRONT OR REAR OF UNIT. USE FORKLIFT FROM SIDE ONLY.

NOTE: To avoid equipment damage, remove the Mobile Oil Trolley before moving this appliance with a forklift or pallet lift.

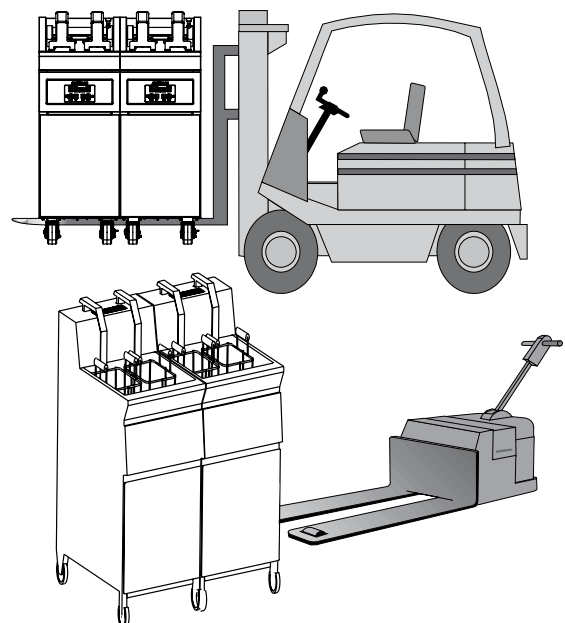

INSTALLATION

SITE INSTALLATION

1. It is the responsibility of the installer to verify that this installation is in compliance with the specifications listed in this manual and with local code requirements.
2. Hood installation is required.
3. Both cooking and cleaning functions require unobstructed access. The frypots, control panels, and front access doors must be maintained free from obstruction. The front access door and back panel must be accessible for service and maintenance.
4. Locate the appliance on a firm, level surface ONLY. The surrounding area must be kept clear of all combustible materials.
5. **FOR YOUR SAFETY DO NOT** store or use any flammable liquids or allow flammable vapors in the vicinity of this fryer or any other appliance.
6. **FOR YOUR SAFETY DO NOT** place insulation or any other type of materials in clearance areas.
7. When properly installed, the fryer is designed for operation adjacent to non-combustible floors and walls with a 6" clearance at the back. Clearances from all combustible construction is a minimum of 6" (152mm) at the back and both sides. Concrete, tile, terrazzo, or metal surfaces are recommended. Metal over a combustible material may not meet code for non-combustible surfaces. Verify site selection with local codes for specific requirements. **Doit être utilisé seulement sur des planchers non inflammables.**
8. Adequate means must be provided to limit the movement of this appliance. A restraining device is required for field installation.

9. DO NOT install this appliance in any area where it may be affected by any adverse conditions such as steam or dripping water, etc. DO NOT install fryer over a drain.
10. **LEVELING:** Make certain the appliance is positioned firmly on all supporting casters. Level from front-to-back and side-to-side by holding lower collar (#2) while twisting upper collar (#1). Restraining ties can be used for stabilization if necessary. Use an allen wrench (#3) to lock caster in position.

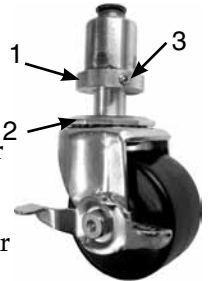

WARNING

BURN WARNING: Make certain the fryer is stabilized before operation to prevent any movement or tipping and the possibility of severe burns caused by hot, splashing shortening or oil.

CAUTION



TO PREVENT PERSONAL INJURY, USE CAUTION WHEN MOVING OR LEVELING THIS APPLIANCE.

DANGER



To avoid electrical shock, this appliance **MUST** be adequately grounded in accordance with local electrical codes or, in the absence of local codes, with the current edition of the National Electrical Code ANSI/NFPA No. 70. In Canada, all electrical connections are to be made in accordance with CSA C22.1, Canadian Electrical Code Part 1 or local codes.

WARNING



IMPROPER INSTALLATION MAY RESULT IN FIRE. Carefully read and follow all installation instructions located in this manual.

INSTALLATION

VENTILATION

DANGER



Installation, air adjustment and/or service work must be in accordance with all local codes and must be performed by a certified service technician qualified to work on gas appliances.

An adequate ventilation system is required for commercial cooking equipment. Information may be obtained by writing to the National Fire Protection Association, Batterymarch Park, Quincy, MA 02269. When writing refer to NFPA No. 96.

1. A single ASF-60G auto-lift gas fryer requires a minimum of 120 CFM make-up air for natural gas and 48 CFM for propane gas. Kitchen ventilation must be of sufficient capacity to prevent a negative-pressure condition. **DO NOT** obstruct or restrict ventilation nor the air flow required to support combustion.
2. **DO NOT** obstruct the flow of the exhaust flue at the top rear of the fryer. It is especially critical that gas supply piping and electrical support cord and/or receptacle be routed away from the path of the hot combustion fumes.
3. This fryer cannot be direct vented.
4. Install the fryer under a ventilation hood meeting all applicable code requirements. Combustion fumes must be vented in accordance with local, state, or national codes.

CAUTION



To prevent malfunction or cause negative back draft, **DO NOT** obstruct exhaust flues or attach any flue extension that will impede proper burner operation.



DANGER

**FAILURE TO VENT THIS FRYER PROPERLY
MAY BE HAZARDOUS TO THE
HEALTH OF THE OPERATOR.**

Equipment damage and operational problems may also be the consequence of improper venting. Any damages sustained by a failure to properly vent this fryer are not covered under warranty.

Ventilating hoods and exhaust systems shall be permitted to be used to vent appliances installed in commercial applications.

Where automatically operated appliances are vented through a ventilating hood or exhaust system equipped with a damper or with a power means of exhaust, provisions shall be made to allow the flow of gas to the main burners only when the damper is open to a position to properly vent the appliance and when the power means of exhaust is in operation. IN ACCORDANCE WITH NFPA 54 COMMONWEALTH OF MASSACHUSETTS ONLY.

INSTALLATION

GAS SPECIFICATIONS

The Alto-Shaam open gas fryer has been set to operate with either natural gas or propane as indicated on the fryer identification name plate.

⚠ DANGER

CONNECTING TO THE WRONG GAS SUPPLY COULD RESULT IN FIRE OR AN EXPLOSION CAUSING SEVERE INJURY AND PROPERTY DAMAGE.

WARNING

TO AVOID SERIOUS PERSONAL INJURY, installation of this appliance must conform to local, state, and national codes; the current edition of the American National Standard Z223.1, National Fuel Gas Code, and all local municipal building codes. In Canada, installation must be in accordance with Standard CAN/CSA B 149.1 and Installation Codes - Gas Burning Appliances, and local codes.

Category	I _{2H} at 20 mbar for use in AT, DK, FI, IE, IT, PT, SE, CH.
Category	I _{2E(20)} at 20/25 mbar for use in DE, LU.
Category	I _{2E+(20/25)} at 20/25 mbar for use in BE, FR.
Category	I _{2L(25)} at 25 mbar for use in NL.
Category	I _{3+(28-30/37)} at 28-30/37 mbar for use in BE, FR, IE, IT, LU, PT, CH.
Category	I _{3B/P(30)} at 30 mbar for use in DK, FI, NL, SE.
Category	I _{3B/P(50)} at 50 mbar for use in AT, DE, CH.
Category	I _{3P(37)} at 37 mbar for use in FI, DE, IE, CH.

Declared input (kW)	35.15
Gas Group	I _{2H(20)} , I _{2E(20)} , I _{2E+(20/25)} , I _{2L(25)} , I _{3+(28-30/37)} , I _{3B/P(30)} , I _{3B/P(37)} , I _{3B/P(50)} , I _{3P(37)} , I _{3P(50)}
Inlet pressure (mbar)	17.5 (NAT) and 27.5 (LP)
Declared setting pressure at the outlet from the gas valve (mbar)	12.5 (NAT) and 25 (LP)
Main burner type	Infrared type with blower and venturi valve
Number of injectors	1
Main injector type	N/A
Main injector size and markings	N/A
Main burner aeration opening size	Variable pre-set at factory
Ignition	Direct spark electronic ignition
Inlet connection	20.995 mm male thread

The appliance and its individual shutoff valve must be disconnected from the gas supply piping system during any pressure testing of that system at test pressures in excess of 1/2 psi. The appliance must be isolated from the gas supply piping system by closing its individual manual shutoff valve during any pressure testing of the gas supply piping system at test pressures equal to or less than 1/2 psi.

NOTE: Customer/installer must provide manual gas shut-off valve in accordance with local code requirements.

GAS FRYER TECHNICAL SPECIFICATIONS		
Natural Gas ←		
Min. Connected Pressure	5.0" W.C.	1.2 kPa
Max. Connected Pressure	11.0" W.C.	2.74 kPa
Gas Consumption	120 CFM	
Gross Thermal Output	120,000 Btu/hr	
Propane Gas ←		
Min. Connected Pressure	10.0" W.C.	2.5 kPa
Max. Connected Pressure	14.0" W.C.	3.5 kPa
Gas Consumption	48 CFM	
Gross Thermal Output	120,000 Btu/hr	

INSTALLATION REQUIREMENTS		
GAS CONNECTION: 1/2" NPT FOR A SINGLE GAS KETTLE 1-1/2" NPT FOR 2, 3, OR 4 GAS KETTLES		
HOOD INSTALLATION IS REQUIRED		
Check plumbing codes for proper supply line sizing to attain minimum burner manifold pressure shown: <table style="width: 100%; border: none;"> <tr> <td style="width: 50%;">NATURAL GAS: 5.0" W.C. (1.2 kPa)</td> <td style="width: 50%;">PROPANE GAS: 10.0" W.C. (2.5 kPa)</td> </tr> </table>	NATURAL GAS: 5.0" W.C. (1.2 kPa)	PROPANE GAS: 10.0" W.C. (2.5 kPa)
NATURAL GAS: 5.0" W.C. (1.2 kPa)	PROPANE GAS: 10.0" W.C. (2.5 kPa)	
MAX. RECOMMENDED INLET PRESSURE: 11" W.C (2.74 kPa) 14" W.C. (3.5 kPa)		
NOTE: If a flexible gas line is used, it must be AGA approved, commercial type and at least 1/2" I.D.		
Manual gas shut-off valve and restraining device must be installed per code requirements when using a quick disconnect device.		
<i>NOT FACTORY SUPPLIED</i>		

INSTALLATION

GAS SPECIFICATIONS

DANGER



Installation, air adjustment and/or service work must be in accordance with all local codes and must be performed by a certified service technician qualified to work on gas appliances.

Use an approved gas pipe sealant at all external threaded connections, gas piping used on gas connections must avoid sharp bends that may restrict the flow of gas to the appliance. If the connected pressure exceeds 14.0" W.C. (3.5 kPa) for propane and 11.0" W.C. (2.74 kPa) for natural gas, a step-down regulator is required to be supplied by the owner/operator.

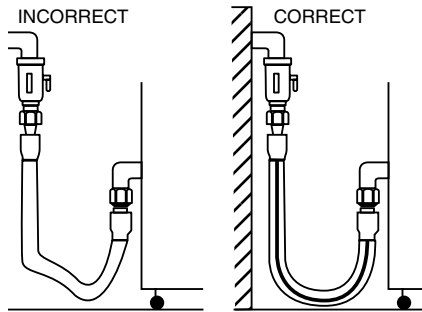

Close the individual manual shut-off valve to *isolate the fryer* from the gas supply piping system during any pressure testing at test pressures equal to or less than 1/2 psig. (3.4 kPa). The fryer and individual shut-off valve *must be disconnected* from the gas supply piping system during any pressure testing at pressures in excess of 1/2 psig. (3.4 kPa).

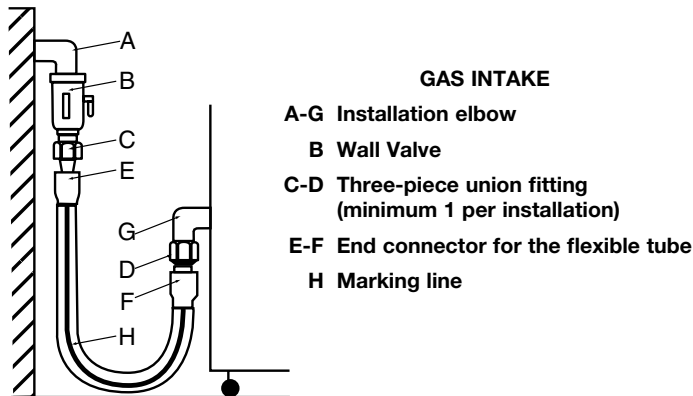

In the U.S.A., installation must conform to local codes or, in the absence of local codes, with the current edition of the *National Fuel Gas Code*, NFPA-54 and ANSI Z83.11a CSA 1.8a 2004 (or latest edition). In Canada, installation must be in accordance with local codes, CAN/CGA-B149.1, *Installation for Natural Gas Burning Appliances and Equipment* (latest edition) or CAN/CGA-B149.2 *Installation for Propane Burning Appliances and Equipment* (latest edition).

The inlet supply line must be properly sized to accommodate all individual appliances simultaneously used on the same line but must never be smaller than 3/4" I.D.

LEAK TESTING

Installation requires gas leak testing on all gas piping and fittings. Use an approved electronic leak device or a soap and water solution at all gas connections. If bubbling appears when using a soap and water solution, the connection must be refitted. Never use an open flame to leak test.



DANGER



NEVER USE AN OPEN FLAME TO LEAK TEST.

INSTALLATION

RESTRAINT REQUIREMENTS - MOBILE EQUIPMENT

The fryer must be supplied with a connector that complies with all state and local installation codes.

Any appliance that is not furnished with a power supply cord but that includes a set of casters must be tethered. Adequate means must be provided to limit the movement of this appliance without depending on or transmitting stress to the electrical conduit.

The following requirements apply:

1. Casters must be a maximum height of 4-inches (102mm).
2. Such mobile appliances must be installed with the use of a flexible connector secured to the building structure.

A mounting connector for a restraining device is located on the upper back flange of the appliance chassis, approximately 31" (787mm) from the floor.

A flexible connector is not supplied by nor is it available from the factory.

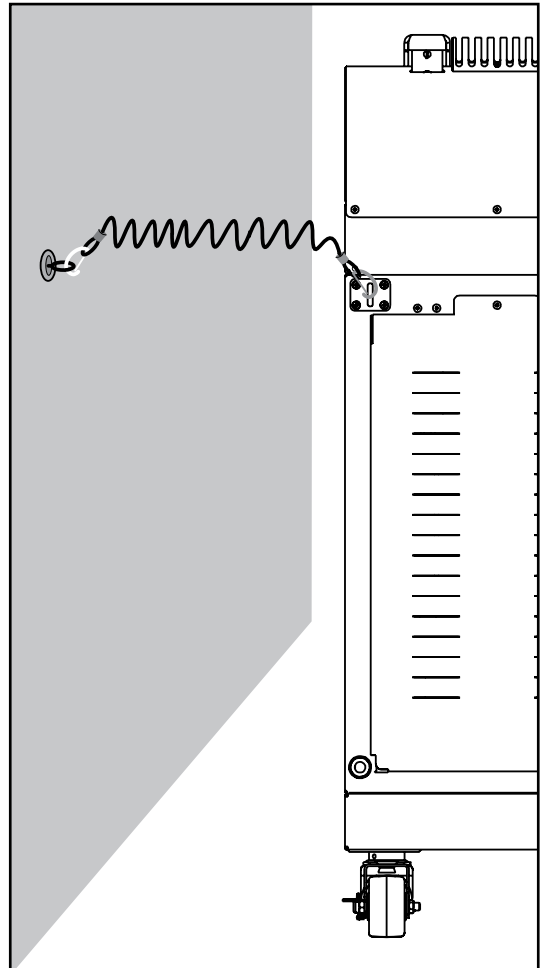

 WARNING	
	RISK OF ELECTRIC SHOCK.
	Appliance must be secured to building structure.

INSTALLATION

ELECTRICAL REQUIREMENTS

DANGER



To avoid electrical shock, this appliance **MUST** be adequately grounded in accordance with local electrical codes or, in the absence of local codes, with the current edition of the National Electrical Code ANSI/NFPA No. 70. In Canada, all electrical connections are to be made in accordance with CSA C22.1, Canadian Electrical Code Part 1 or local codes.



DANGER



ENSURE POWER SOURCE MATCHES VOLTAGE IDENTIFIED ON APPLIANCE RATING TAG.

An electrical wiring diagram is located in the fryer kettle. The fryer must be installed by a qualified electrician. This appliance must be branch circuit protected with proper ampacities, in accordance with the wiring diagram. The fryer must be properly grounded in accordance with the National Electrical Code and applicable local codes. A means to disconnect the unit must be incorporated into the fixed wiring in accordance with wiring codes.

Wire size for the main incoming power to the unit must match the minimum size listed in the specifications applicable to the specific fryer.

Before operating the fryer, check all cable connections in the electrical connection area for tightness since connections can loosen during transport.

For CE approved units: To prevent an electrical shock hazard between the appliance and other appliances or metal parts in close vicinity, an equalization-bonding stud is provided. An equalization bonding lead must be connected to this stud and the other appliances / metal parts to provide sufficient protection against potential difference. The terminal is marked with the following symbol.







Hard wired models:

Hard wired models must be equipped with a country certified external allpole disconnection switch with sufficient contact separation.

If a power cord is used for the connection of the product an oil resistant cord like H05RN or H07RN or equivalent must be used.

ELECTRICAL NOTE: Multiply the total number of fryers and dump stations in battery by the respective electrical specifications below to determine the total electrical draw.

ELECTRICAL FOR ADDITIONAL KETTLE						
VOLTAGE	PHASE	CYCLE/HZ	AMPS	kW	CORD & PLUG	
120	1	60	2.2	0.27		NEMA 5-15P 15A-125V PLUG
230	1	50	1.0	0.23		CEE 7/7 220-230V PLUG

ELECTRICAL • ASF-60DS DUMP STATION						
VOLTAGE	PHASE	CYCLE/HZ	AMPS	kW	CORD & PLUG	
120	1	60	8.3	1.0		NEMA 5-15P 15A-125V PLUG
230	1	50	4.4	1.0		CEE 7/7 220-230V PLUG

OIL/SHORTENING REQUIREMENTS

OIL/SHORTENING REQUIREMENTS

Each ASF-60G frypot requires 62-pounds (28 kg) of oil or shortening. Use only quality, high-grade oil/shortening in the fryer. The high moisture content of lower grade shortening will result in excessive foaming and boil over. The cold oil/shortening level requirement for the fryer is indicated below.

CAUTION

Cold oil or shortening expands as the temperature increases. To avoid injury and equipment damage, allow for expansion by filling to the cold oil fill line.

NOTE: ALWAYS maintain the proper level of shortening by adding fresh oil/shortening to the frypot whenever needed.

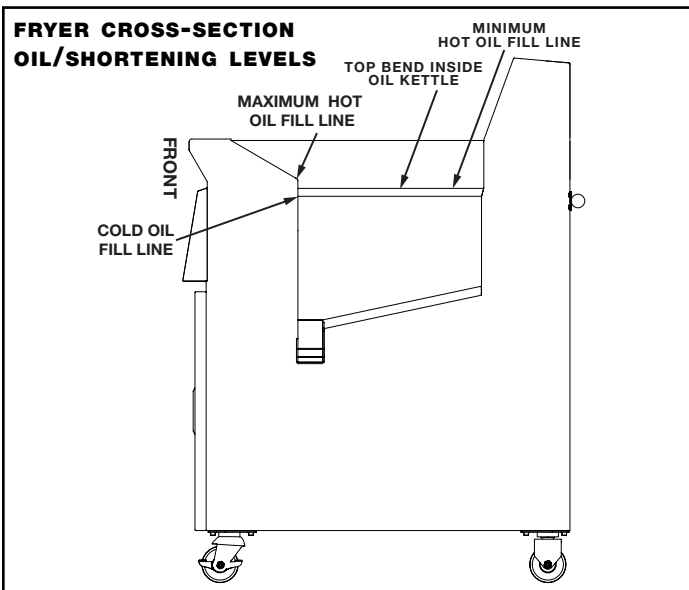

WARNING

FAILURE TO PLACE SOLID SHORTENING DIRECTLY ON THE BOTTOM OF THE FRYPOT CAN CAUSE SERIOUS EQUIPMENT DAMAGE.



DANGER



FLASH POINT

The flash point of shortening occurs at a lower temperature the longer the shortening is used. Discard any shortening showing signs of deterioration to avoid serious burns, fire, and property damage.

Check the quality of the oil/shortening in the frypots on a daily basis for signs of deterioration. Use an approved test kit. Signs of shortening deterioration include excessive boiling, smoking, foaming, bad taste, and rancid odor. Discard any shortening before it degrades to the point of affecting product quality. Always filter the oil on a regular basis and keep the frypot clean.

CAUTION

ENSURE THERE IS NO WATER IN THE FRYPOT BEFORE FILLING WITH OIL/SHORTENING. WHEN COOKING COMPOUNDS ARE HEATED TO COOKING TEMPERATURE, WATER IN THE FRYPOT WILL CAUSE OIL TO SPLATTER AND MAY BE A BURN HAZARD.

Remove ice crystals and ensure that food is dry before frying. Excessive water and ice can cause oil to splatter or overflow. Do not over fill the basket. Food needs to be surrounded by oil for best frying results.

Maximum shortening life is achieved by lowering the temperature of the fryer to 250°F (121°C) or turning the fryer station off when not in use. In multiple-station units, heat only the component fryers necessary to meet cooking needs.

CAUTION

FIRE OR EQUIPMENT DAMAGE CAN RESULT FROM IMPROPER SHORTENING LEVELS. THE LEVEL OF SHORTENING MUST ALWAYS BE ABOVE THE HEAT EXCHANGERS WHEN THE FRYER IS OPERATING. THE REQUIRED SHORTENING LEVEL MUST ALWAYS BE ABOVE THE MINIMUM HOT OIL FILL LINE.

CAUTION



METAL PARTS OF THIS EQUIPMENT BECOME EXTREMELY HOT WHEN IN OPERATION. TO AVOID BURNS, ALWAYS USE HAND PROTECTION WHEN OPERATING THIS APPLIANCE.

OPERATION

START UP & GENERAL OPERATION

DANGER



BEFORE STARTING THE APPLIANCE, MAKE CERTAIN YOU DO NOT DETECT THE ODOR OF GAS.

IF THE ODOR OF GAS IS DETECTED:

- **DO NOT** attempt to light any appliance.
- **DO NOT** touch any electrical switches.
- Extinguish any open flame.
- Use a telephone **OUTSIDE THE PROPERTY & IMMEDIATELY** contact your gas supplier.
- If unable to contact your gas supplier, contact the fire department.

NOTE: FOR YOUR PROTECTION The fryer is furnished with a hi-limit safety shutoff that will disengage the control if the frying compound temperature in the frypot would ever exceed 406°F (208°C). The **LED** will display **“HI”**, the heat will shut off, the timer will be cancelled, and a constant alarm will sound. In this event, allow the frying compound temperature to drop below 375°F (191°C). Open the front access door and press the **OIL HI-LIMIT RESET** button for a period of 3 seconds to restart the control.

NOTE: Perform an initial Boil-Out to clean and sanitize the kettle(s) before operating.

1. Service is to be performed by an authorized Alto-Shaam service agent.
2. Ensure all local electrical codes, fire codes, and all other requirements such as hood installation have been met in the process of installation.
3. Open front access door and ensure Kettle Drain valve is in the **CLOSED** position. The handle should be rotated clockwise until it stops.
4. Fill frypot with frying compound as indicated. (SEE ILLUSTRATION ON THE OIL/SHORTENING REQUIREMENTS PAGE)
5. The Master Power Switch is located behind the front access door. Turn Master Power Switch **“ON.”**
6. Press the **ON/OFF** power button on the control.
7. **“READY”** will be displayed when fryer reaches set temperature.

More detailed operating guidelines along with information on programming are located within this manual.
8. To shutdown the fryer, turn the Master Power Switch located behind the front access door to the **“OFF”** position.



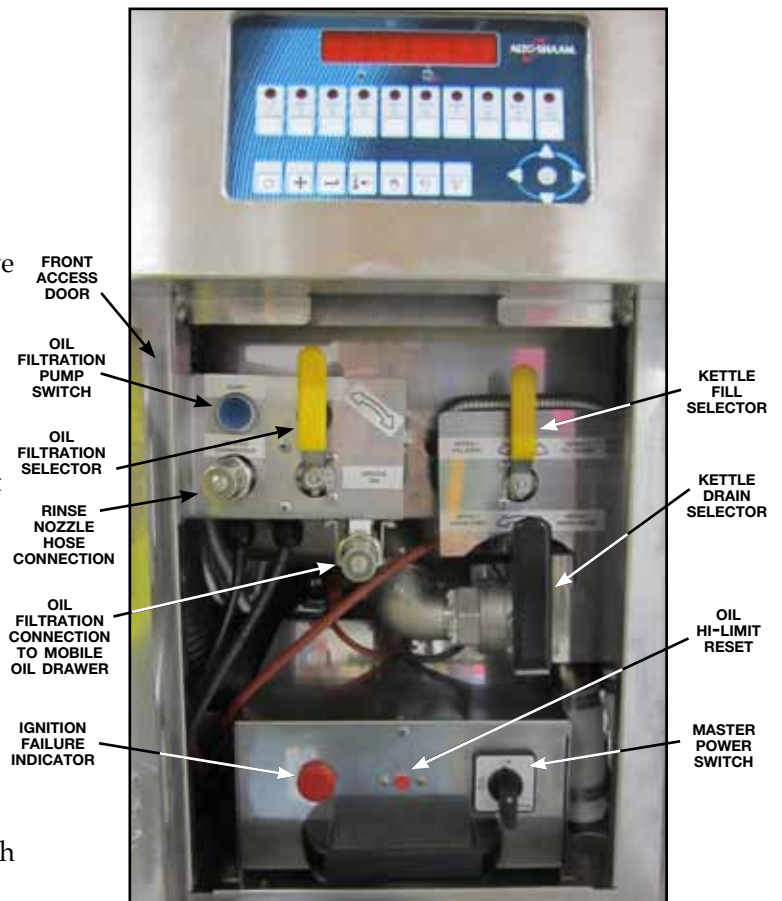

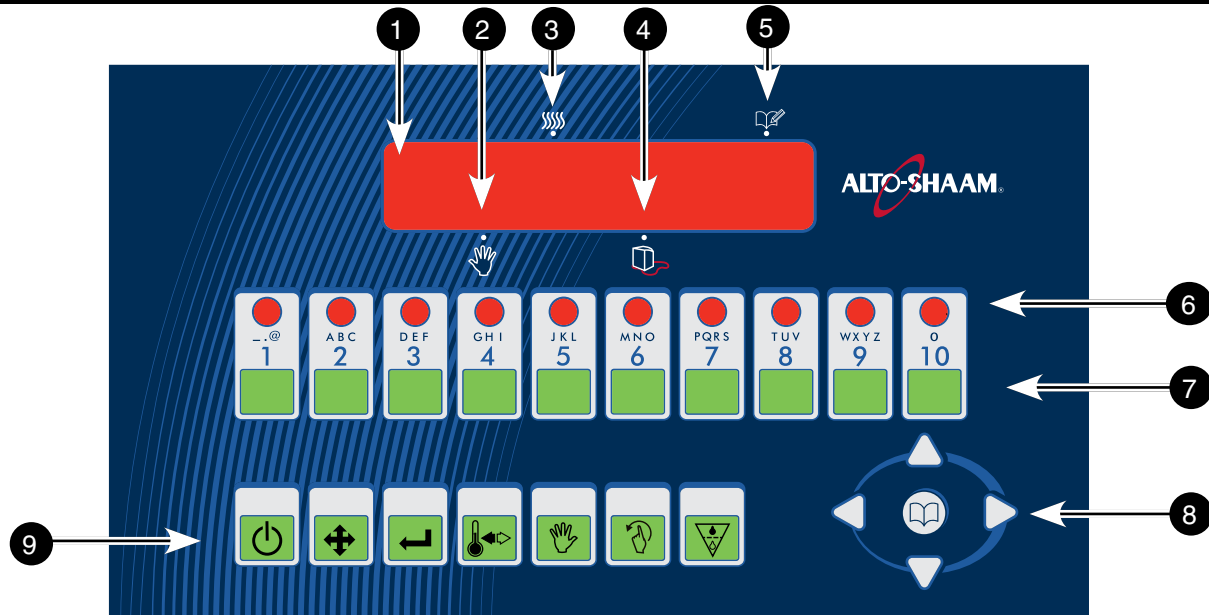

ASF-60G BATTERY





1. LED DISPLAY
2. HOLD INDICATOR
3. HEAT INDICATOR
4. MELT CYCLE INDICATOR
5. PROGRAM INDICATOR
6. PRODUCT KEY INDICATOR LIGHTS: Illuminate during active cook cycle or programming mode.
7. PREPROGRAMMED PRODUCT KEYS: Press to start a cook cycle. Also used in programming. **REPLACEABLE MENU STRIP:** Make menu changes quickly and easily.
8. PROGRAMMING CENTER: Easy cell phone-like programming. Access programming mode, preprogrammed menu items, and change cooking parameters.
9. FEATURE KEYS: Used to access programming functions and controller features.

FEATURE KEYS

-  ON/OFF KEY
-  SCAN KEY: Shows time left between recipe / baskets
-  ENTER KEY: Used while entering your own menu / time
-  TEMP TOGGLE CLEAR KEY
-  HOLD KEY: Displays remaining hold time
-  SETBACK KEY: Reverts to reduced oil temperature while fryer is idle
-  FILTER KEY (NOT ENABLED)

LEFT BASKET (1-5)

PRODUCT KEY PRESET TIMES:

- 1 - 2:45 minutes
- 2 - 3:00 minutes
- 3 - 3:15 minutes
- 4 - 3:30 minutes
- 5 - 3:45 minutes

RIGHT BASKET (6-10)

PRODUCT KEY PRESET TIMES:

- 6 - 2:45 minutes
- 7 - 3:00 minutes
- 8 - 3:15 minutes
- 9 - 3:30 minutes
- 10 - 3:45 minutes

OPERATION

OPERATING THE CONTROL

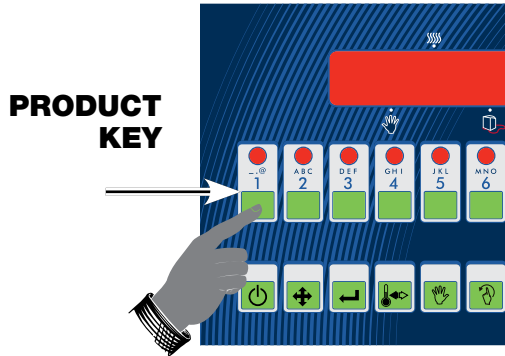

Start a Cook Cycle

Press any product key to start a cook cycle. If the key is programmed, the cooking time will be displayed and will immediately start to count down in minutes and seconds. *DONE* will display when the cook cycle has ended.

The pressure solenoid will also close if programmed to do so, or a basket lift will lower if so equipped. If *DONE* is displayed immediately and the unit starts to beep, the product key being pressed is not programmed.

Stop a Cook Cycle

Press and hold an active product key for 3 seconds. Timing will stop, and basket will lift if so equipped.

Respond to a *DONE* Alarm

Cancel the signal by pressing the same product key used to start the cook cycle.

Action Alarms

If the controller is programmed for action alarms, they will signal at a preset time during the cooking cycle. The signal, a dual-rhythm beeping, will last 5 seconds and then self-cancel. The display will flash the action alarm time and the controller will start counting toward 0:00.



Holding Timers

If the product menu is programmed with holding times, they will automatically start counting upon expiration of the cook cycle.



When there are active hold times, the *HOLD*  indicator light will be lit.

To view all active hold times, press and hold the  key. Upon expiration, the timer will display *HOLD* and pulse with a beep.

To Cancel, press the  key.

Check Product Counts



Press and hold the  key for 3 seconds. *COUNTS* will be displayed.

Press the  key. *PRODT* will be displayed then the number of cooks that were completed on that key. To see the number for each key, continue to press the  key and each product will display *PROD X* then the number of cooks.



Resetting the Product Counts

Once you go through all keys, the display will show *CLRPROD* then *NO*. Use the left and right arrow keys to toggle between *YES* and *NO*. Choose *YES* to reset your product count or *NO* to save the cook counts that have already been completed. Then press the  key.

The display will show *GLOBAL*. This is the total product count of all keys combined. Press the  key again. *CLRGLOBL* then *NO* will be displayed. Use the left and right arrow keys to toggle between *YES* and *NO*. Choose *YES* to reset your total product count or *NO* to save the total cook counts that have already been completed. Then press the  key.

TOTALXTD is displayed, then a number. Press the  key again.

Exit Product Counts

COUNTS will be displayed. Press the up arrow key. *EXIT* will be displayed. Press the  key. The controller will exit programming mode.

Display Descriptions

2:30

Controller is in Operating Mode and a cook cycle is in progress.

Controller is in Operating Mode. Actual vat temperature is within the proper cooking temperature range. The vat is ready to start a cook cycle.

DROP

READY

ALTIME1

Action alarm status is displayed.

APPLIANC

Controller is in Appliance Type Programming Mode.

CODE

Controller is waiting for a pass code to be entered.

DONE

Controller is in Operating Mode and a cook cycle has been completed.

HI

Controller is in Operating Mode. The actual vat temperature is more than 40 degrees above the highest programmed vat temperature. A continuous audible signal will sound.

OPERATION

Display Descriptions (continued)

LO

Controller is in Operating Mode. The actual vat temperature is more than 10 degrees below the programmed vat temperature.

PROBE

Controller's probe is either open or shorted. Display will be accompanied with an audible alarm if shorted. Check or replace the probe.

PRODUCT

Controller is in Product Key Programming Standby mode.

SYSTEM

Controller is in System Programming Standby Mode.

TEMP

Stage cooking temperature.

TEMPUNIT

Controller is in Fahrenheit or Celsius Programming Mode.

TIME

Stage cooking time.

TIMING

Stage timing mode (flex or straight).

PRODUCT KEY PROGRAMMING

10-button controllers have a single, dual-purpose display that will alternate information; for example:

TIME then 2:00

Recipe Programming Code (1724) Manager

ENTER PROGRAMMING MODE.
Press and hold the  key for 3 seconds.

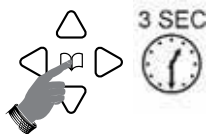

COUNTS

Press the down arrow key.



PROGRAM

PROGRAM will be displayed.
Press the  key.

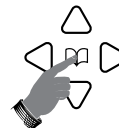

PRODUCT KEY PROGRAMMING (CONTINUED)

CODE

Type in 1 7 2 4 using the product keys. Press the  key.

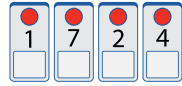

RECIPE

Press the  key. All product key LEDs will light up.



PRODUCT

PROGRAM A PRODUCT KEY. Press the product key you want to program. Press the  key.

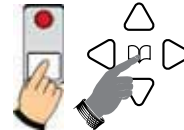

Depending on model, you can either press the  key to change all programmable settings or you can scroll using the arrow keys to any of the specific options.

Note: The Recipe Library contains more than 100 different choices.

ALL

Press .

NAME

XXXXXXXXXX

SET PRODUCT DISPLAY NAME. NAME will be displayed then the actual product name. Use the up and down arrow keys to scroll through the library. Press  to lock in your choice.

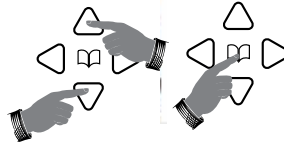

TIME

XX:XX

SET COOK TIME. Actual set time will be displayed. To change, press toggle clear to change the time to zero. Type in a new time using the product keys. Press .

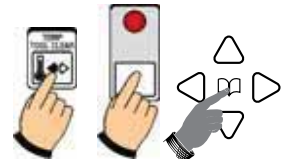

TIMING

STRAIGHT

FLEX

SENSITIV

SET TIMING MODE. Use the left and/or right arrow keys to choose Straight, Flex or Sensitivity. Press .

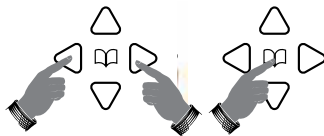

ALMNAME1

XX:XX

SET ACTION ALARM. Actual alarm time 1 will be displayed. To change, press toggle clear to change the time to zero. Type in a new time using the product keys. Press .

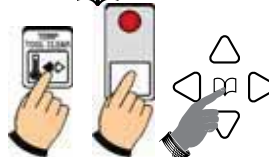

ALMNAME1

XXXXXXXXXX

SET ACTION ALARM NAME. ALMNAME1 will be displayed, then the actual action alarm name. Use the up and down arrow keys to scroll through the library. Press  to either go to next action alarm name, or continue through programming.

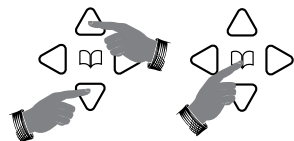

HOLDTIME

XX:XX

SET HOLD TIME. Actual hold time will be displayed. To change, press toggle clear to change the time to zero. Type in a new time using the product keys. Press .

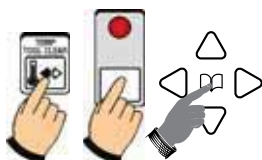

ALL

EXIT PROGRAMMING MODE. Press the up arrow key.

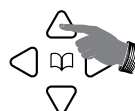

EXIT

Press .

OPERATION

PRODUCT KEY PROGRAMMING (CONTINUED)

PRODUCT

Either press another product key to program and repeat the programming instructions, or continue by pressing the down arrow key.

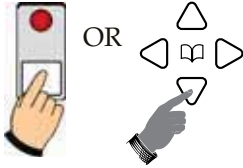

SET TEMP

SET GLOBAL TEMPERATURE.

Press .

SET TEMP

XXXX

SET TEMP, then *Actual Temp* will be displayed. To change, use the number keys and then press .

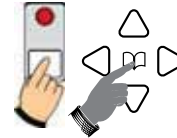

To Exit, press the down arrow key.

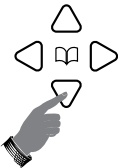

EXIT

Press .

RECIPE

Press the up arrow key.



EXIT

Press .

SYSTEM PROGRAMMING

SYSTEM CODE (3228) MANAGER

Enter System Programming Mode. Press and hold  for 3 seconds.

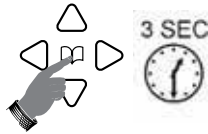

COUNTS

Press the down arrow key.



PROGRAM

PROGRAM will be displayed. Press .

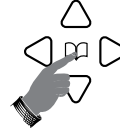

CODE

Type in 3 2 2 8 using the product keys. Press .

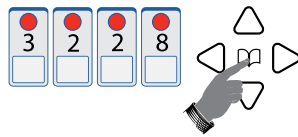

SYSTEM

Press .

APPLIANC

GAS

ELEC

GEN

SET APPLIANCE MODE. Use the left and/or right arrow keys to choose Gas, Electric or Generic. Press .

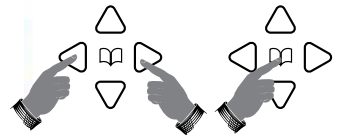

Note: Preheat is also known as a melt cycle. Yes is used for solid shortening, No is used for oil.

CTRTYPE

TEMPCTRL

TIMECTRL

SET CONTROL TYPE. Use the left and/or right arrow keys to choose Temperature or Time Control. Press .

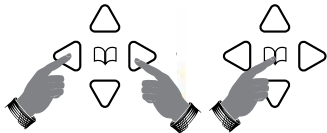

TEMPUNIT

F

C

SET TEMPERATURE SCALE. Use the left and/or right arrow keys to choose Fahrenheit (F) or Celsius (C). Press .

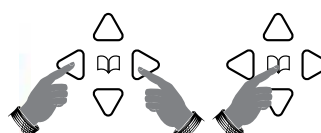

PREHEAT

YES

NO

SET PREHEAT MODE. Use the left and/or right arrow keys to choose Yes or No. Press .

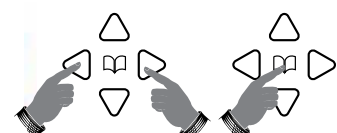

COOKUNIT

MM:SS

HH:MM

SET COOK TIME UNIT. Use the left and/or right arrow keys to choose Minutes/Seconds or Hours/Minutes. Press .

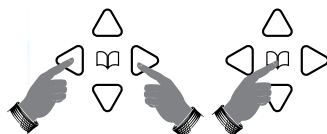

SYSTEM

EXIT SYSTEM PROGRAMMING MODE. Press the up arrow key.



EXIT

Press .

READY

You have now EXITED System Programming Mode and can operate the controller.

OPERATION

PROGRAMMING CUSTOM PRODUCT AND ACTION ALARM NAMES TO THE LIBRARY

SYSTEM CODE
(3228)
MANAGER

ENTER LIBRARY PROGRAMMING MODE.
Press and hold  for 3 seconds.

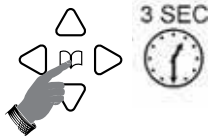

COUNTS

Press the down arrow key.

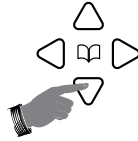

PROGRAM

PROGRAM will be displayed.
Press .

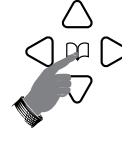

CODE

Type in 3 2 2 8 using the product keys. Press .

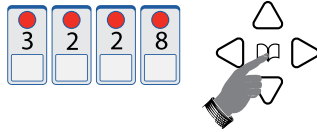

SYSTEM

Press the down arrow key to select either *PRODLIBR* or *ALRMLIBR*.

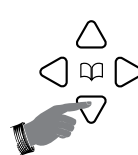

PRODLIBR

ALRMLIBR

Choose either *PRODLIBR* (Product Library) or *ALRMLIBR* (Action Alarm Library) by pressing .

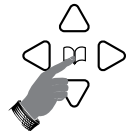

-

A flashing dash will be displayed. Press the  key and use the product keys to spell a new word. Press the right arrow key to advance to the next character position.

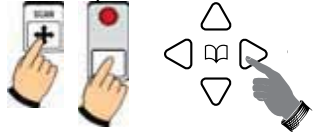

AB

Continue spelling the word.
When done, press .



ADD

TO SAVE WORD, press  again. Skip to Exit Library Programming.

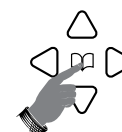

TO CANCEL OR MODIFY, see next step.

ADD

CANCEL

MODIFY

TO CANCEL OR MODIFY WORD, press the left or right arrow keys to choose **CANCEL** or **MODIFY**.

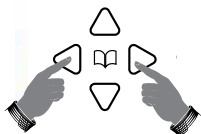

IF YOU CHOOSE CANCEL:

CANCEL

Press  to EXIT and cancel the word.

PRODLIBR

ALRMLIBR

EXIT LIBRARY PROGRAMMING.

Use the up or down arrow keys until display reads EXIT.

IF YOU CHOOSE MODIFY:

MODIFY

Press the  key to go back and modify the word.

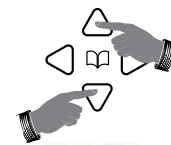

EXIT

Press .

READY

You have now EXITED Library Programming Mode and can operate the controller.

OPERATION

ALL SUGGESTED FRYING TIMES ARE BASED ON A FULL LOAD OF PRODUCT

Remove ice crystals and ensure that food is dry before frying. Excessive water and ice can cause oil to splatter or overflow. Do not over fill the basket. Food needs to be surrounded by oil for best frying results.

SUGGESTED FRYING TIMES

ITEM		MINUTES	TEMPERATURE	DISPLAY
PROGRAM KEYS	1. Fries (FROZEN)	3:30	350°F (177°C)	Fries
	2. Chicken Nuggets (FROZEN)	3:30	350°F (177°C)	Nuggets
	3. Fish, Breaded (FROZEN)	4:30	350°F (177°C)	Fish
	4. Chicken Pieces, Breaded (FRESH)	17:00	340°F (171°C)	Chicken
	5. PRODUCT A			ProductA
	6. PRODUCT B			ProductB

ITEM	MINUTES	TEMPERATURE
Appetizer	3:30	350°F (177°C)
Breaded Cauliflower	3:30	340°F (171°C)
Breaded Fish	Per pkg. instructions	340°F (171°C)
Breaded Mac & Cheese	3:30	340°F (171°C)
Breaded Mushrooms	3:30	340°F (171°C)
Broccoli Cheese Nuggets	2:30	350°F (177°C)
Cheese Cake, Fried	8:30	350°F (177°C)
Cheese Nuggets	1:30	350°F (177°C)
Chicken Breasts (FRESH)	12:00-17:00	315°F (157°C)
Chicken Breasts (FROZEN)	20:00	330°F (166°C)
Chicken Fried Steak	4:00	350°F (177°C)
Chicken Gizzards (FRESH)	3:30	350°F (177°C)
Chicken, Legs & Wings (FRESH)	12:00-17:00	315°F (157°C)
Chicken Legs (FROZEN)	18:00	330°F (166°C)
Chicken, Patty	6:00	350°F (177°C)
Chicken Pieces - MRB (FROZEN)	17:00	340°F (171°C)
Chicken Strips	6:00	340°F (171°C)
Chicken Tenderloins (FRESH)	3:00	350°F (177°C)
Chicken Tenders, Breaded (FROZEN)	3:30	350°F (177°C)
Chicken Wings (FRESH)	3:30	350°F (177°C)
Chicken Wings (FROZEN)	15:00	330°F (166°C)
Clam Strips	2:00	340°F (171°C)
Corn Dogs	10:00	350°F (177°C)
Cream Cheese Jalapeño Poppers	3:30	340°F (171°C)

THE TIMES AND TEMPERATURES ARE SUGGESTED GUIDELINES ONLY. ALL COOKING SHOULD BE BASED ON INTERNAL PRODUCT TEMPERATURES. DUE TO VARIATIONS IN PRODUCT QUALITY, WEIGHT, AND DESIRED DEGREE OF DONENESS, THE COOKING TIMES AND TEMPERATURES MAY NEED TO BE ADJUSTED ACCORDINGLY. ALWAYS FOLLOW LOCAL HEALTH (HYGIENE) REGULATIONS FOR ALL INTERNAL TEMPERATURE REQUIREMENTS.

OPERATION

ALL SUGGESTED FRYING TIMES ARE BASED ON A FULL LOAD OF PRODUCT

Remove ice crystals and ensure that food is dry before frying. Excessive water and ice can cause oil to splatter or overflow. Do not over fill the basket. Food needs to be surrounded by oil for best frying results.

SUGGESTED FRYING TIMES		
ITEM	MINUTES	TEMPERATURE
Eggplant	4:00	340°F (171°C)
Egg Rolls (FROZEN)	5:00	340°F (171°C)
Fries, Crinkle-Cut	5:00	340°F (171°C)
Fries, Seasoned	4:00	340°F (171°C)
Fries, Sour Cream & Chive	4:00	340°F (171°C)
Fries (FRESH)	5:00	340°F (171°C)
Fries, Thin Cut	3:30	340°F (171°C)
Hash Brown Circles	4:00	340°F (171°C)
Jalapeno Peppers, Stuffed	4:00	350°F (177°C)
Mozzarella Sticks, Battered or Breaded	Per pkg. instructions	340°F (171°C)
Mushrooms, Breaded	3:30	350°F (177°C)
Onion Rings	3:00	340°F (171°C)
Pork Chops (FRESH)	10:00	340°F (171°C)
Pork (FRESH)	12:00	340°F (171°C)
Potato Chips (fresh)	2:45	325°F (163°C)
Potato Wedges	3:00	350°F (177°C)
Quesadilla Rolls	3:30	350°F (177°C)
Shrimp	3:30	340°F (171°C)
Vegetables	3:00	350°F (177°C)
Zucchini, Breaded (FRESH)	3:30	350°F (177°C)

THE TIMES AND TEMPERATURES ARE SUGGESTED GUIDELINES ONLY. ALL COOKING SHOULD BE BASED ON INTERNAL PRODUCT TEMPERATURES. DUE TO VARIATIONS IN PRODUCT QUALITY, WEIGHT, AND DESIRED DEGREE OF DONENESS, THE COOKING TIMES AND TEMPERATURES MAY NEED TO BE ADJUSTED ACCORDINGLY. ALWAYS FOLLOW LOCAL HEALTH (HYGIENE) REGULATIONS FOR ALL INTERNAL TEMPERATURE REQUIREMENTS.

DAILY CLEANING & MAINTENANCE



DANGER



DISCONNECT UNIT FROM POWER SOURCE BEFORE CLEANING OR SERVICING.



DANGER

TO AVOID SERIOUS PERSONAL INJURY DO NOT STAND ON THE FRYER OR FRYER COVER. THE FRYER COVER IS DESIGNED TO HOLD A MAXIMUM OF 10-POUNDS (4,5 KG) OF WEIGHT.

THOROUGHLY CLEAN DAILY

The cleanliness and appearance of this unit will contribute considerably to operating efficiency and savory, appetizing food. Good equipment kept clean works better and lasts longer.

1. Disconnect unit from power source, and let cool.
2. Remove all detachable items. Clean these items separately with a good grease solvent or commercial detergent. Rinse well and dry.
3. Clean control panel, door hinges, and door handles thoroughly since these areas harbor food debris. Rinse by wiping with sponge and clean warm water. Wipe dry with a clean cloth.

4. To help maintain the protective film coating on polished stainless steel, clean the exterior of the unit with a cleaner recommended for stainless steel surfaces. Spray the cleaning agent on a clean cloth and wipe with the grain of the stainless steel.

NOTE: Avoid the use of abrasive cleaning, compounds, chloride based cleaners, or cleaners containing quaternary salts. Never use hydrochloric acid (muriatic acid) on stainless steel.

Always follow appropriate state or local health (hygiene) regulations regarding all applicable cleaning and sanitation requirements for foodservice equipment.

DANGER



AT NO TIME SHOULD THE INTERIOR OR EXTERIOR BE STEAM CLEANED, HOSED DOWN, OR FLOODED WITH WATER OR LIQUID SOLUTION OF ANY KIND. DO NOT USE WATER JET TO CLEAN.



SEVERE DAMAGE OR ELECTRICAL HAZARD COULD RESULT.

WARRANTY BECOMES VOID IF APPLIANCE IS FLOODED



CAUTION



TO PROTECT STAINLESS STEEL SURFACES, COMPLETELY AVOID THE USE OF ABRASIVE CLEANING COMPOUNDS, CHLORIDE BASED CLEANERS, OR CLEANERS CONTAINING QUATERNARY SALTS. NEVER USE HYDROCHLORIC ACID (MURIATIC ACID) ON STAINLESS STEEL. NEVER USE WIRE BRUSHES, METAL SCOURING PADS OR SCRAPERS.

CLEANING

OIL FILTRATION INSTRUCTIONS

Careful observation of the finished food product will help determine optimal filtering frequency. Filtering the cooking oil at regular intervals will help ensure food quality.

FOR BEST RESULTS: Do not allow the temperature of the oil to decrease below the “**setback**” temperature of 250°F (121°C) when filtering. If filtering at the end of the day, pump oil back into the kettle while still hot. Do not allow oil to cool in mobile oil drawer before returning to kettle.

CAUTION

OPERATORS MUST BE MADE AWARE OF THE HAZARDS INVOLVED IN THE OPERATION OF A HOT OIL FILTERING SYSTEM. ON-SITE SUPERVISION DURING THE FILTRATION PROCESS AND THE CLEANING PROCESS IS STRONGLY RECOMMENDED.

CAUTION



METAL PARTS OF THIS EQUIPMENT BECOME EXTREMELY HOT WHEN IN OPERATION. TO AVOID BURNS, ALWAYS USE HAND PROTECTION WHEN OPERATING THIS APPLIANCE.

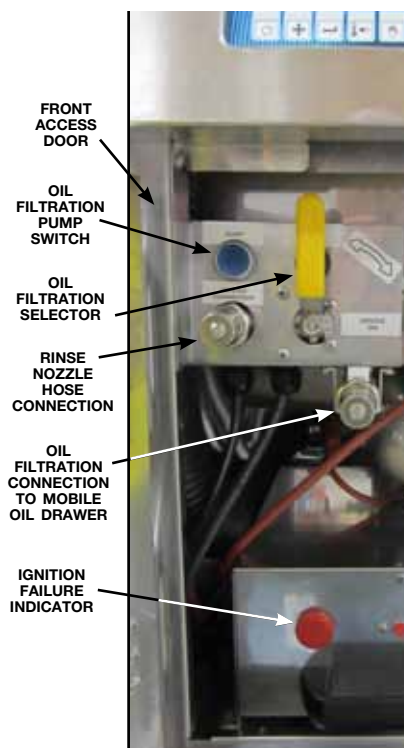

1. Identify the kettle that requires oil filtration. Only 1 kettle can be drained at a time.
2. Open the front access door. Place the mobile oil drawer under the drain. Carefully place filter cartridge into the bottom of the mobile oil drawer and connect the hose to the filtration hose connection fitting. With the Nozzle valve in the “**NOZZLE OFF**” position, *slowly* rotate the Kettle Drain valve counterclockwise until rotation stops and the Kettle Drain valve is in the “**OPEN**” position. Power to the main control panel will automatically switch “**OFF.**”
3. Allow contents of the fryer to completely drain into the mobile oil drawer.
4. Connect the optional oil discard hose/nozzle to the rinse nozzle hose connection and point nozzle into the kettle being filtered. Rotate rinse nozzle valve “**ON.**”
5. Press the **PUMP “ON”** to allow the oil to circulate through the drain system to flush crumbs. Using the brushes provided, brush the sides and bottom of the fryer while the oil is circulating through the system.
6. Press the **PUMP “OFF”** and allow contents of the fryer to completely drain. Disconnect oil discard hose/nozzle and drain hose into kettle.
7. Rotate the Kettle Drain and Rinse Nozzle valves clockwise to the “**CLOSED**” position.
8. Press the **PUMP “ON”** and allow the fryer to refill to the recommended level adding additional oil/shortening as required to maintain proper fill level.
9. Press the **PUMP “OFF”** button.
10. After the frypot has completely refilled, pull out the mobile oil drawer and filter cartridge. See Filter Replacement instructions. Discard the disposable paper or carbon filter into a proper receptacle, or clean off reusable mesh filter. Clean the filter assembly and oil drawer, if needed.
11. Replace the oil filter cartridge and return the drawer to the proper position beneath the fryer.

WARNING



TO AVOID PERSONAL INJURY, USE CAUTION WHEN SURFACES BECOME SLIPPERY DUE TO SPILLED OR DRIPPING OIL.

OIL FILTRATION INSTRUCTIONS

FILTER CLEANING & MAINTENANCE

NOTE: Make certain to use hand protection when working with hot surfaces.

REUSABLE MESH FILTER OPTION:

Clean the reusable mesh filter (**FI-27014**) by spraying thoroughly with hot water. **DO NOT** clean in the dishwasher. **DO NOT** use detergents to clean. Detergents and detergent residues will significantly reduce the life of oil and shortening products.

CAUTION

A WORN FILTER WILL AFFECT PRODUCT FRYING RESULTS.

Make certain the filter is performing efficiently by inspecting the filter each time it is cleaned. Examine for cuts and holes. For the best results, replace the filter whenever necessary.

CAUTION

TO PREVENT FILTER DAMAGE, DO NOT USE SHARP IMPLEMENTS TO REMOVE SCRAPS FROM THE FILTER.

Make certain the filter is securely fastened to the filter frame and cartridge before returning the assembly to the mobile oil drawer.

To discard deteriorated oil/shortening, the drawer can be pulled from the fryer and can be rolled to a convenient location for use with a pumping device.

ALWAYS MAKE CERTAIN THE DRAWER IS PROPERLY POSITIONED BENEATH THE FRYER BEFORE OPERATION.

WARNING



TO AVOID PERSONAL INJURY, USE CAUTION WHEN SURFACES BECOME SLIPPERY DUE TO SPILLED OR DRIPPING OIL.

CAUTION



METAL PARTS OF THIS EQUIPMENT BECOME EXTREMELY HOT WHEN IN OPERATION. TO AVOID BURNS, ALWAYS USE HAND PROTECTION WHEN OPERATING THIS APPLIANCE.

FILTER REPLACEMENT

1. With the Kettle Drain valve in the **“CLOSED”** position, pull the mobile oil drawer from the fryer and disconnect the filtration hose from the fryer. Take care when pulling trolley from fryer as it has sharp edges.
2. Pushing down on filter frame **4** clip, pull side of filter cartridge **1** closest to clip upwards. Slide opposite edge of filter cartridge out from beneath the filter frame lip.
3. Remove used filter **2** and filter ring **3**. Discard filter **2**. Retain filter ring **3**.
4. Place new filter **2** and filter ring **3** next to screen on underside of filter cartridge **1**. Reverse step 2 above.
5. Reconnect filtration hose to fryer and return mobile oil drawer to its position under the fryer.

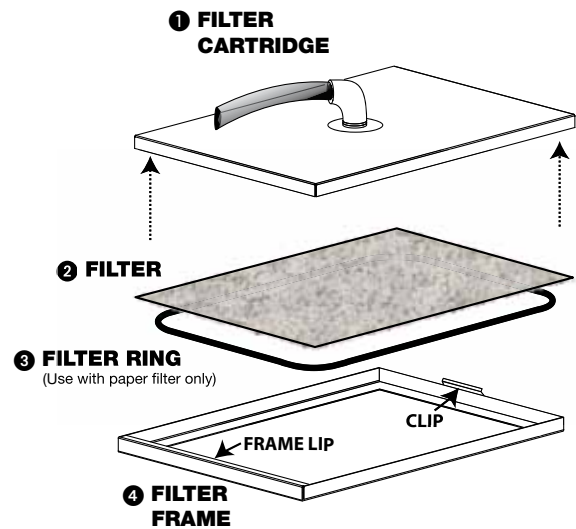

OPTIONS	
Filters	
<input type="checkbox"/> Paper, 7 count refill package	FI-27791
<input type="checkbox"/> Paper, 100 count refill package	FI-27794
<input type="checkbox"/> Charcoal/Carbon, 30 count package	FI-27648
<input type="checkbox"/> Reusable Mesh, single filter	FI-27014
<input type="checkbox"/> Frypot Cover	CONTACT FACTORY
<input type="checkbox"/> Mobile Drawer Cover	5006073
<input type="checkbox"/> Mobile Oil Caddy (WITH OIL DISCARD HOSE)	TO-28359
<input type="checkbox"/> Oil Discard Hose	HO-28812
<input type="checkbox"/> Pre-Filter Sieve Kit	5010451
<input type="checkbox"/> Strainer/Skimmer	CE-27400

OIL FILTRATION INSTRUCTIONS

OIL DISCARD/RINSE HOSE:

The oil discard hose assists both the boil-out and filtration operation.

To rinse out kettle crumbs and circulate used oil through the filter with optional oil discard hose:



1. Connect filtration hose to the filtration hose connection and carefully place the filter cartridge in mobile oil drawer.
2. Move empty mobile oil drawer into location under drain(s).
3. On the kettle to be rinsed and circulated through the filter, *slowly* rotate the Kettle Drain valve to **“OPEN”**.
4. Rotate the Kettle Fill valve to **“CLOSED”**.
5. Using heat resistant gloves, carefully connect the optional oil discard/rinse hose to the Rinse Nozzle Hose Connection and point the oil discard/rinse hose nozzle into the kettle being drained or rinsed.
6. Rotate the Rinse Nozzle valve of the draining kettle to **“OPEN”**.
7. After 1/3 or more of the kettle’s oil has drained into the oil drawer, press the **“PUMP”** button to turn the circulation pump on. If the kettle’s drain valve is still **“OPEN”** the oil will continue to circulate out through the kettle drain, through the filter and pump, and back into the kettle through the oil discard/rinse hose.
8. When finished rinsing, rotate the Kettle Drain valve to **“CLOSE”** which will end the circulation process and begin to fill the kettle.
9. If preferred, the kettle can be filled automatically and the user will not be required to hold the hose. To do so, rotate the kettle’s Kettle Fill valve to **“OPEN”** and move the Rinse Nozzle valve to **“NOZZLE OFF”**.

Note: Never run the filtration pump when all the Kettle Fill Valves and Nozzle Valve are closed or if neither of the hoses for the filtration or rinse nozzle are connected. (The oil must have somewhere to travel or the pump will over-heat.)

10. When all the used oil in the mobile oil drawer has been pumped back into the kettle, press the **“PUMP”** button to turn it off.
11. Repeat these steps for other frypots as needed or rotate all the valves to **“CLOSE”** when done.
12. Using heat resistant gloves, carefully disconnect the rinse nozzle hose and drain any extra oil in the hose back into the kettle.

ASF-60G BATTERY

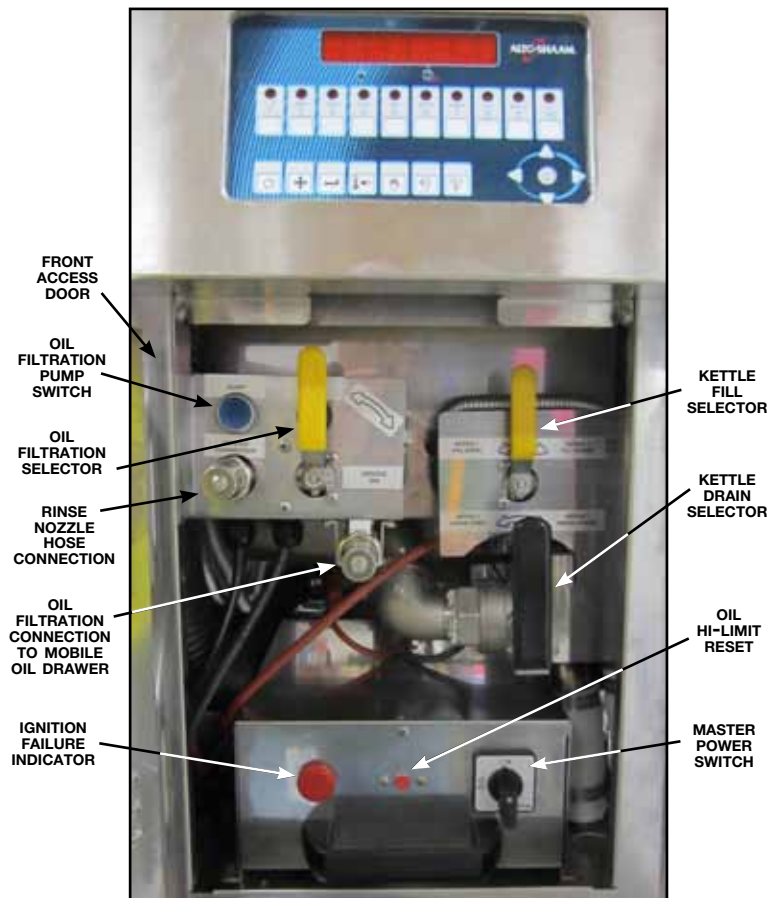

BOIL-OUT PROCEDURE

NOTE: Perform an initial boil-out to clean and sanitize the fryer before operating.

Carbonized deposits along with an accumulation of oil will eventually build-up on the interior of the frypot as well as fryer accessories. It is important to periodically remove these deposits, not only to maintain fryer efficiency, but also to provide the highest product quality.

NOTE: Always wear eye protection or a face shield and protective rubber gloves when cleaning the frypot as boil-out chemical is an alkaline solution and can cause severe burns.

NOTE: Because each fryer is controlled separately, the following procedure must be followed for every unit.

NOTE: Manual Boil-Out can only be performed when the actual temperature of the frypot is less than 210°F (99°C).

NOTES: Before and during boil-out:

Before draining any kettle, be sure the mobile oil drawer or heat safe container is in its location underneath the drain(s).

DO NOT DRAIN MORE THAN ONE KETTLE AT A TIME. THE MOBILE OIL DRAWER ONLY HAS ENOUGH CAPACITY FOR ONE KETTLE.

1. Open the front access door. Place the mobile oil drawer under the drain. *Slowly* rotate frypot Kettle Drain valve to **“OPEN”** to drain oil.
2. While wearing heat resistant gloves, wipe excess oil out of inside of frypot with paper towel or clean rag.
3. Empty the oil from the mobile oil caddy. Wash the oil caddy, rinse with clean water, and dry caddy thoroughly.
4. Rotate the drained fryer’s Kettle Drain valve clockwise until rotation stops and the drain valve is **“CLOSED.”**

CAUTION

BEFORE ENTERING THIS PROGRAM, MAKE CERTAIN THE FRYPOT IS EMPTY OF ALL OIL OR SHORTENING.

CAUTION

TO AVOID DAMAGING THE PUMP AND CONTAMINATING CLEAN OIL WITH BOIL-OUT CHEMICAL ON UNITS EQUIPPED WITH A FILTRATION SYSTEM, NEVER ALLOW BOIL-OUT SOLUTION OR RINSE WATER TO CIRCULATE THROUGH THE FRYER PUMP SYSTEM.

CAUTION

BOIL-OUT SOLUTION AND SURROUNDING METAL SURFACES BECOME EXTREMELY HOT. TO AVOID BURNS, ALWAYS USE HAND PROTECTION WHEN PERFORMING THE BOIL-OUT FUNCTION AND FOLLOW THE MANUFACTURER’S SAFETY INSTRUCTIONS FOR THE BOIL-OUT PRODUCT BEING USED.

CAUTION





DO NOT LEAVE THE FRYER UNATTENDED DURING THE BOIL-OUT PROCESS. THE FRYER MUST BE CONTINUOUSLY MONITORED FOR BOIL-OVER CONDITIONS, PARTICULARLY IN HIGH-ALTITUDE LOCATIONS.

CAUTION

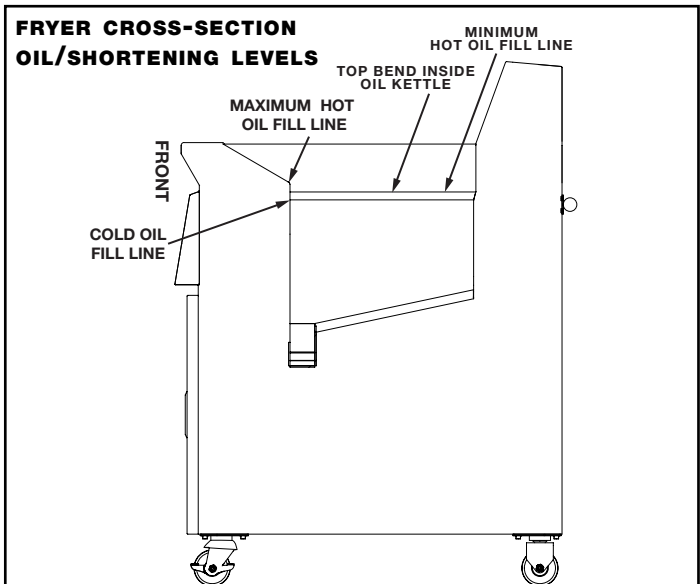
KEEP A CONTAINER OF COLD WATER ON HAND DURING BOIL-OUT IN CASE OF BOIL-OVER. IF BOIL-OVER IS IMMINENT, IMMEDIATELY POUR COLD WATER INTO FRYPOT TO QUICKLY REDUCE SOLUTION TEMPERATURE. TURN OFF MASTER POWER SWITCH AND ALLOW SOLUTION TO COOL. WHEN THE SOLUTION HAS COOLED, RE-ENTER THE BOIL-OUT MODE.

5. Fill the fryer to the maximum oil fill line with water.



6. Add boil out solution. Carefully follow the manufacturer's directions for mixing the boil-out solution.
7. Turn the Master Power Switch (located behind the front access door) to the **"ON"** position and press the **CONTROL RESET**.
8. To enter Boil Mode, press and hold the  for 3 seconds. **"COUNTS"** will be displayed.
9. Press the up  or down  arrow keys until **"BOIL"** is displayed, then press . **"BOIL"** will be displayed. Using a separate timer, allow the frypot to boil-out for 10 minutes.
10. After the 10 minute boil-out period, turn the Master Power Switch located behind the front access door to the **"OFF"** position.
11. Wearing protective gloves to avoid burns, scrub the inside of the frypot with a long-handled scrub brush.
12. Place an empty and dry heat-safe container under the drain. Rotate the Kettle Drain valve to the **"OPEN"** position. **The handle should be rotated counterclockwise until it stops.** Allow the boil-out solution to completely drain into the heat-safe container. Discard boil-out solution. Return the heat safe container beneath the fryer.
13. Making sure the Kettle Drain valve is **"OPEN"**, rinse all boil-out solution from frypot, drain, burner holes, oil fill hole, etc. Follow the boil-out solution manufacturer's additional boil-out instructions to rinse the frypot in order to neutralize boil-out cleaner residue. Discard rinse solution.
14. There may be residual boil-out solution in the oil fill-hole and tube. This must be flushed out and discarded separately before filling the tank with new oil to avoid contamination of new oil.

Rinse frypot with a small amount of water.

15. After the boil-out and rinse procedure, wipe dry all accessible interior metal surfaces and interior accessories with a clean, dry cloth to remove remaining moisture. Clean and dry the fry baskets separately.

CAUTION

ENSURE THERE IS NO WATER IN THE FRYPOT BEFORE FILLING WITH OIL/SHORTENING. WHEN COOKING COMPOUNDS ARE HEATED TO COOKING TEMPERATURE, WATER IN THE FRYPOT WILL CAUSE OIL TO SPLATTER AND MAY BE A BURN HAZARD.

NOTE: Make sure the inside of the frypot, the drain opening and all parts that come into contact with new oil/shortening are as dry as possible.

16. Wipe the exterior of the fryer cabinet with a degreaser/sanitizer suitable for use on food contact surfaces. Always follow the manufacturer's instructions and/or mixing directions for proper solution strengths.

Wipe exterior stainless steel surfaces with the grain of the metal and avoid the use of abrasive pads, steel wool, or metal implements.
17. Rotate Kettle Drain valve to **"CLOSED"** position.
18. Fill tank with new oil or shortening.

SERVICE

CONTROL TROUBLESHOOTING

PROBLEM	CAUSE	SOLUTION
No power	Circuit breaker OFF	Check and reset
	Appliance not plugged in	Plug in cord
	Defective 24VAC transformer	Replace transformer Replace controller
No sound	Inoperable speaker	Replace controller
Button problem	Inoperable key	Replace controller
PROBE is displayed	Defective temperature probe	Replace temperature probe
	Probe not plugged in	Plug in probe
Reading wrong temperature	Defective temperature probe	Replace temperature probe.
Not heating	Defective element, relay, contactor or gas valve	Replace defective part
	Defective controller	Replace controller

UNIT TROUBLESHOOTING

PROBLEM	CAUSE	SOLUTION
No power	Circuit breaker OFF	Check and reset
	Appliance not plugged in	Plug in cord
	Drain switch turned to the "OPEN" position	Turn drain switch to the "CLOSED" position
	Master switch turned to the "OFF" position	Turn master switch to the "ON" position
Fryer will not heat	Gas valve is in the "OFF" position	Turn gas valve to the "ON" position
	Gas hose is not connected	Connect gas hose
	Hi-limit is tripped	Press the hi-limit reset button located behind the front access door
	No oil in frypot	Add oil to frypot
Baskets will not drop	Fuse is blown on basket lift relay board	Replace fuse
	Interference with basket lift mechanism	Check basket lift mechanism and remove interference

CAUTION

THIS SECTION IS PROVIDED FOR THE ASSISTANCE OF QUALIFIED SERVICE TECHNICIANS ONLY AND IS NOT INTENDED FOR USE BY UNTRAINED OR UNAUTHORIZED SERVICE PERSONNEL.

**DANGER**

DISCONNECT UNIT FROM POWER SOURCE BEFORE CLEANING OR SERVICING.

CAUTION

IT IS RECOMMENDED THIS APPLIANCE BE INSPECTED BY A QUALIFIED SERVICE TECHNICIAN AT REGULAR INTERVALS AS PART OF A STANDARD KITCHEN MAINTENANCE PROGRAM.

**EXTENDED LIMITED FRYPOT WARRANTY**

Alto-Shaam, Inc. warrants to the original purchaser that any frypot that is found to be defective in material or workmanship will, at Alto-Shaam's option, subject to provisions hereinafter stated, be replaced with a new or rebuilt frypot.

The labor warranty remains in effect for three (3) years from the shipping date. Alto-Shaam will bear shipping and normal labor charges for installation performed during standard business hours, and excluding overtime, holiday rates or any additional fees.

The parts warranty remains in effect for seven (7) years from the shipping date. Following the initial three (3) year labor warranty, Alto-Shaam will replace the frypot only, with freight, labor and all additional charges at the full responsibility of the owner/operator.

Extended frypot warranty coverage is subject to all remaining provisions as set forth in Alto-Shaam's standard published warranty.

SERVICE

ASF-60B GAS FRYER BATTERY (REFERENCE ONLY)

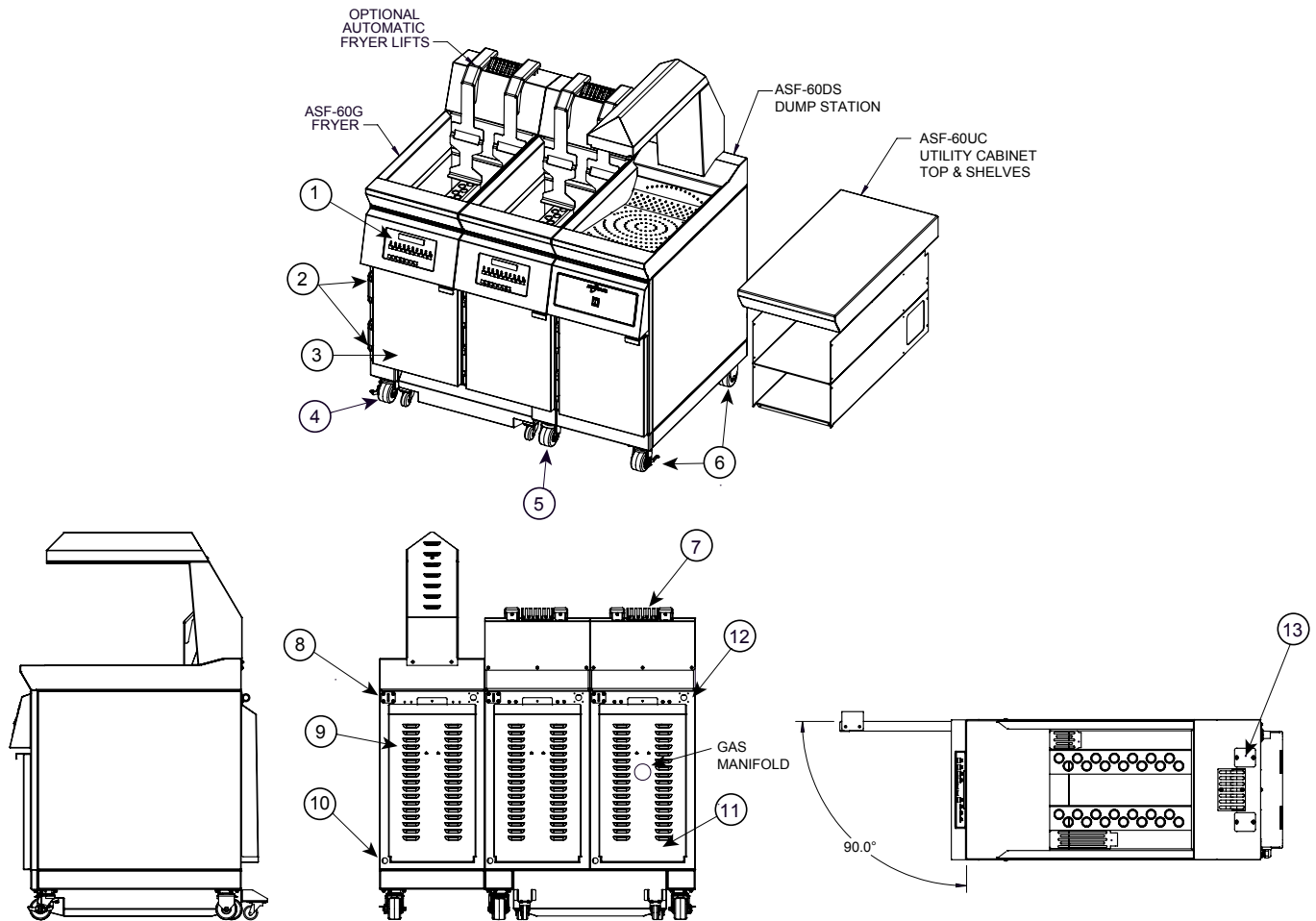

ITEM	P/N	DESCRIPTION	QTY
1	PE-29469	Fryer Panel Overlay	1
2	HG-2015	Hinge Assembly (each appliance)	2
	SC-2072	Screws for Hinge Assembly	6
3	5014682	Door Assembly with Hinges	1
4	CS-28098	Caster, Swivel with brake, left side	2
5	CS-28443	Caster, Swivel	2
6	CS-28099	Caster, Swivel with brake, right side	2
	SC-28891	Screws for Casters	
7	1008769	Exhaust Vent	1
8	BT-26884	Bracket, Tether restraint	1
9	1013139	Panel, Back - without gas manifold	1
10	BU-3964	Bushing, Electrical connection	1
11	1013139	Panel, Back - with gas manifold	1
12	FT-27961	Fitting, Gas connection, 1/2"	1
13	1013188	Plate Cover (each fryer)	2

ASF-60B GAS FRYER KETTLE ASSEMBLY

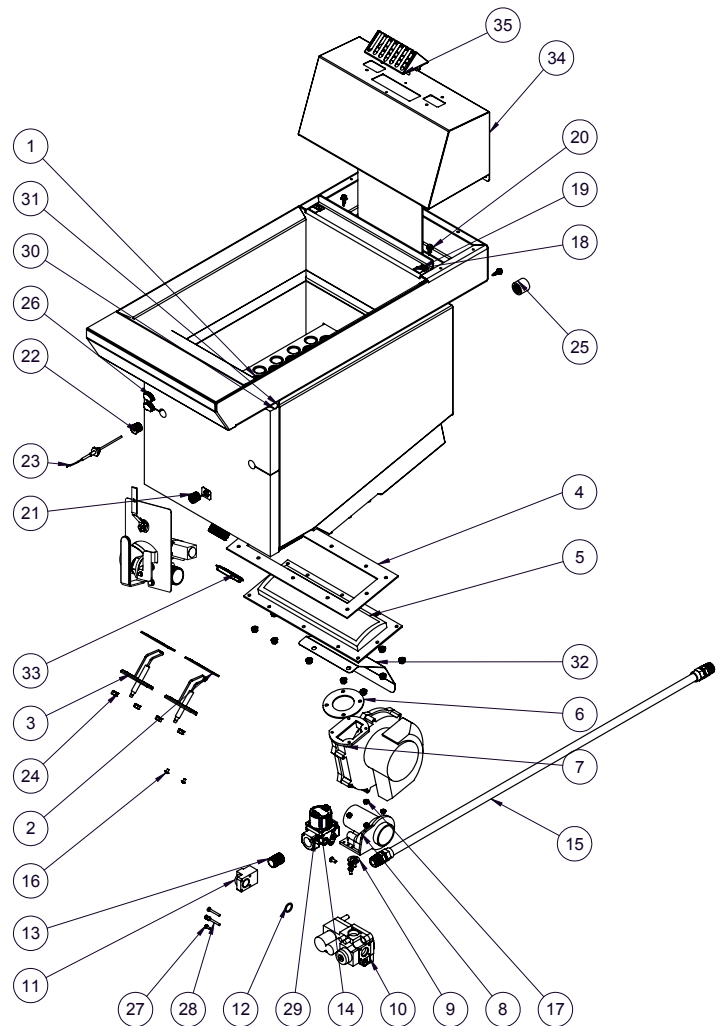

ITEM	P/N	DESCRIPTION	QTY
1	5009432	Kettle, ASF-60G	1
2	SA-27007	Seal, Spark Plug	2
3	PI-27001	Pin, Flame Sensor	2
4	SA-27005	Seal, Gas Burner	1
5	BN-34226	Burner, HE Gas Fryer	1
6	SA-27006	Seal, Fan Burner	1
7	FA-34232	Fan, Gas Fryer, 120V	1
8	VA-27068	Valve, Venturi	1
9	SA-27930	Seal, Gas Valve	1
10	VA-34260	Valve, Safety, 24V	1
11	VA-27081	Elbow, Flange, Venturi	1
12	OR-27249	O-Ring, 0.812 O.D. x .94 Diameter	1
13	NP-26220	Nipple, 1/2"-14 NPT	1
14	VA-34531	Gas Valve, 24V, 120V, 1/2 NPT	1
15	HO-28689	Hose, 1/2" I.D., Corrugated	1
16	SC-2459	Screw, Phillips, 8-32	2
17	NU-27851	Nut, Hex, 5mm with Star Washer	4
18	1008588	Bracket, Chimney Holding	2
19	SC-2661	Screw, Phillips, 10-32	2
20	SC-27384	Screw, Self Drilling, #10-16	4
21	BU-27277	Bushing, Reducing	1
22	BU-29470	Bushing, SS, Reducing	1
23	PR-34998	Probe, Temperature Sensor	1
24	NU-29475	Nut, 1/4"-20 KEPS	16

ITEM	P/N	DESCRIPTION	QTY
25	CP-29478	Cap, 1/2" NPT	1
26	CR-34329	Connector, -2 Conductor	1
27	SC-22273	Screw, Pan Head, M4 x 6MM	2
28	SC-29276	Screw, M4x30MM	2
29	SC-22766	Screw, Pan Head Phillips	5
30	IN-22265	Insulation, Kettle Front	1
31	IN-22265	Insulation, Kettle Top	1
32	1012657	Guard, Drip Combustion Fan	1
33	GL-29744	Sight Glass	1
34	5014906	Cover, Chimney	1
35	1008769	Body, Chimney	1

SERVICE

ASF-60G BATTERY 120V ELECTRICAL PACKAGES

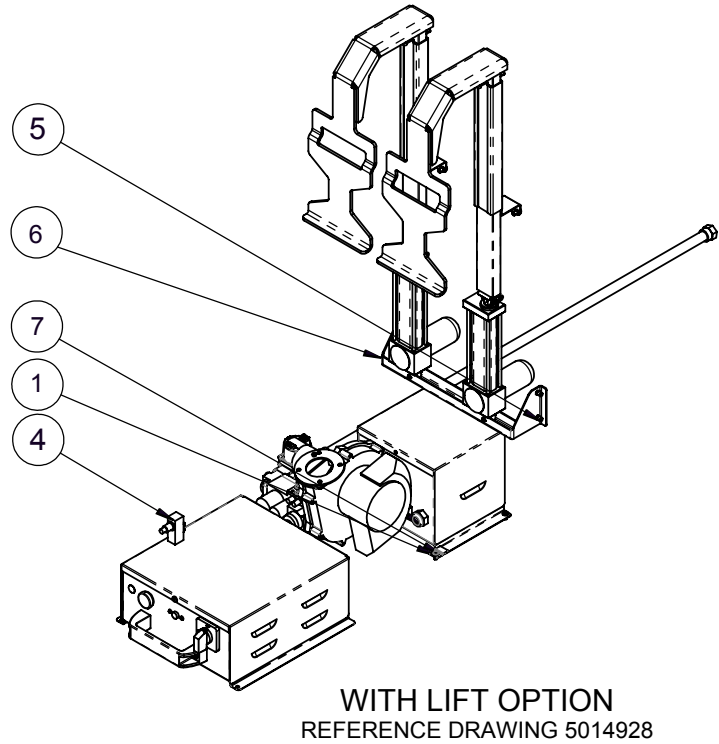
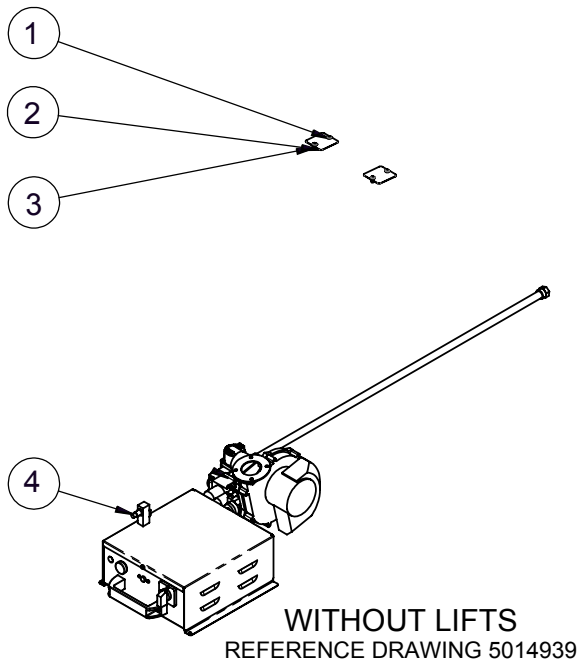

ITEM	P/N	DESCRIPTION	120V with Lift Qty	120V w/o Lift Qty
1	SC-22766	Screw, M5 Pan Head	4	4
2	1013188	Lift Hole Cover Plate	-	2
3	NU-22289	Nut, M5 Hex	-	4
4	SW-33148	Switch, Snap Action	1	1
5	SC-2661	Screw, 10-32 x 1/2" TRH PHH	4	-
6	5014907	Bracket, Lift Lower Assembly	1	-
7	1008588	Bracket, Chimney Holding, ASF-60	2	-

LIFT ASSEMBLY – 5014863 SHOWN

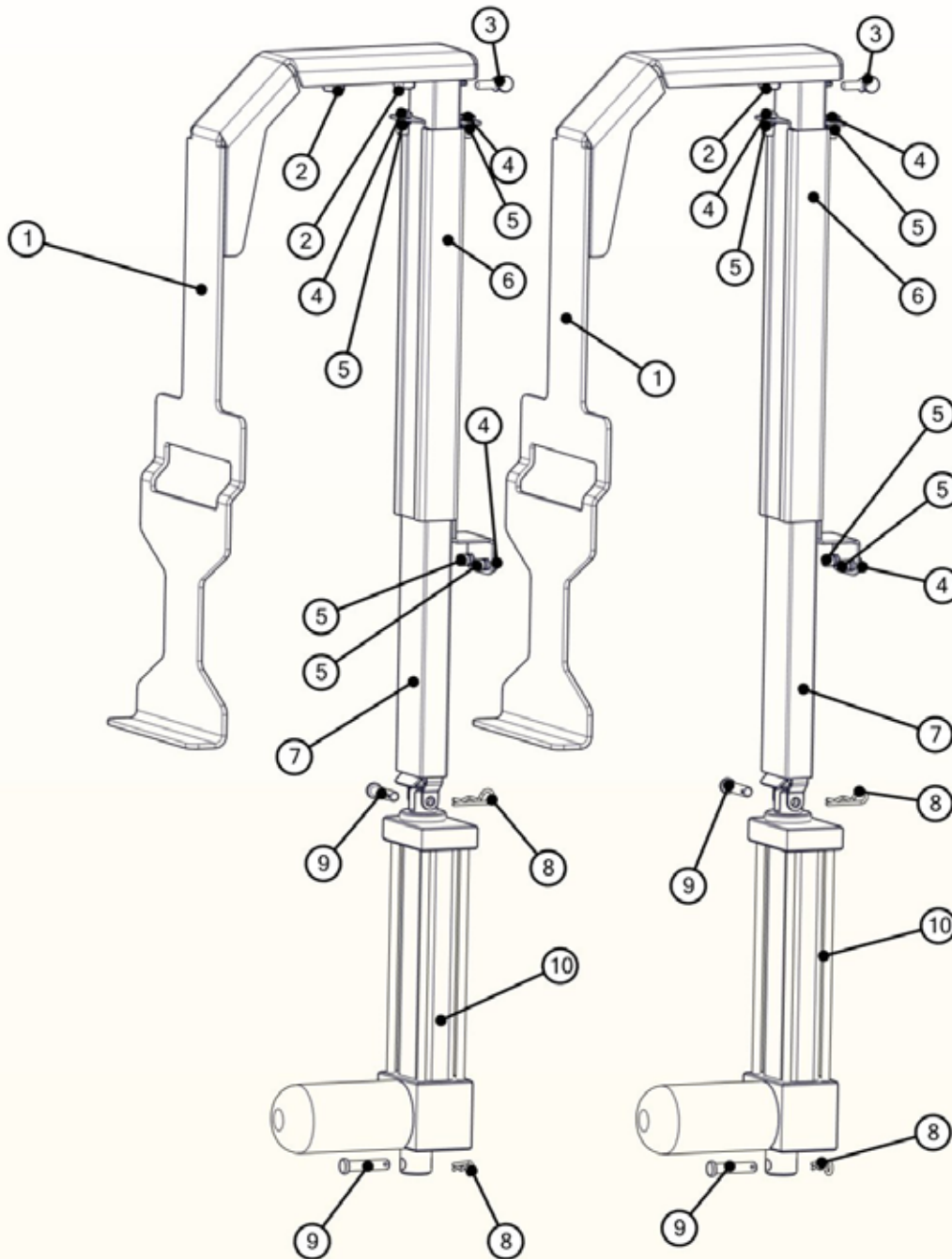

ITEM	PART NUMBER	PART DESCRIPTION	QTY
1	1013362	CARRIER, BASKET ASF-60	2
2	SC-23153	SCREW 5/16-18 X1/2 HEX TRIM HEAD	3
3	SC-2268	SCREW,10-24X1/2,THUMB SHOULDER	2
4	SC-22766	SCREW,M5x0.8X10MM PAN	8
5	NU-23909	NUT, HEX INSERT M5	8
6	1013141	BRKT, LIFT COLUMN, CHANNEL	2
7	1013144	ROD, BASKET LIFT	2
8	PI-27540	PIN-COTTER	4
9	PI-27539	PIN-CLEVIS	4
10	MO-27011	LINEAR-MECH (LMR01RN1 C150 FC2X)	2

SERVICE

ELECTRICAL ASSEMBLY, 120V – ASF-60G

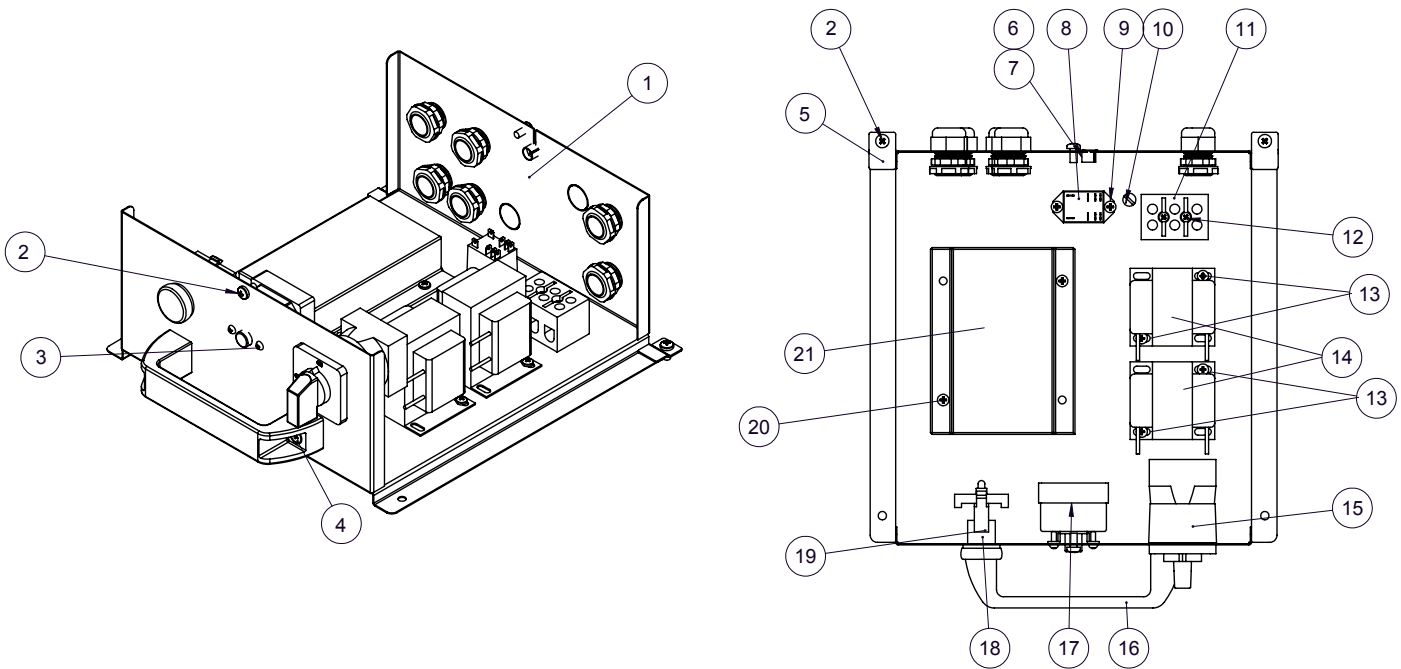

120V CONFIGURATION
REFERENCE DRAWING 5014823

ITEM	P/N	DESCRIPTION	Qty
*	77450	120V Wiring Diagram	1
1	1013069	120V Electrical Box	1
*	1013070	Electrical Box Cover	1
2	SC-22766	Screw, M5	4
3	SC-2254	Screw, 6-32 x 3/8" Round Pan Head	2
4	SC022466	Screw, Philips, 1/4-20 x 1"	2
5	1008588	Bracket, Chimney Holding	2
6	BU-2827	Bushing, Bearing, Nylon	1
7	SA-2924	Seal	1
8	RL-35000	Relay, Power, SPDT	1
9	SC-22500	Screw, Pan Head, 6-32 x 1/4"	2
10	SC-2190	Ground Screw	1
11	BK-3019	T-Block	1
12	SC-2365	Screw, Round Pan Head, 6-32	2
13	SC-22271	Screw, Pan Head, M4	4
14	TN-33282	Transformer, 230V/24V, 50A	2
15	SW-34254	Switch, Cam, for Single Phase	1

ITEM	P/N	DESCRIPTION	Qty
16	HD-26792	Handle	1
17	TT-34245	Thermostat, Hi-Limit	1
18	LT-34280	Light, Ignition Alarm	1
19	NU-2187	Nut, Acorn #18-8	2
20	SC-2069	Screw, Pan Head, 8-32 x 1"	2
21	BN-34266	Ignition Module, Starter	1
*	BU-3964	Bushing, Straight Strain Relief	6
*	CB-34330	Cable, Flame Sensor, Red	1
*	CB-34331	Cable, Flame Ignitor, Black	1
*	CB-34999	Cable, Control	2
*	CD-34094	Cord, Line	1
*	CR-33510	Connector, Terminal .187" Quick	1
*	CR-34318	Connector, Plug, 3 POS, 94V-0	1
*	CR-34646	Connector, 5 Conductor	6
*	LT-34281	Light, Alarm	1
*	PA-27057	Plate, Light Mounting	1

* NOT SHOWN

ELECTRICAL ASSEMBLY, REFERENCE DRAWING 5014722

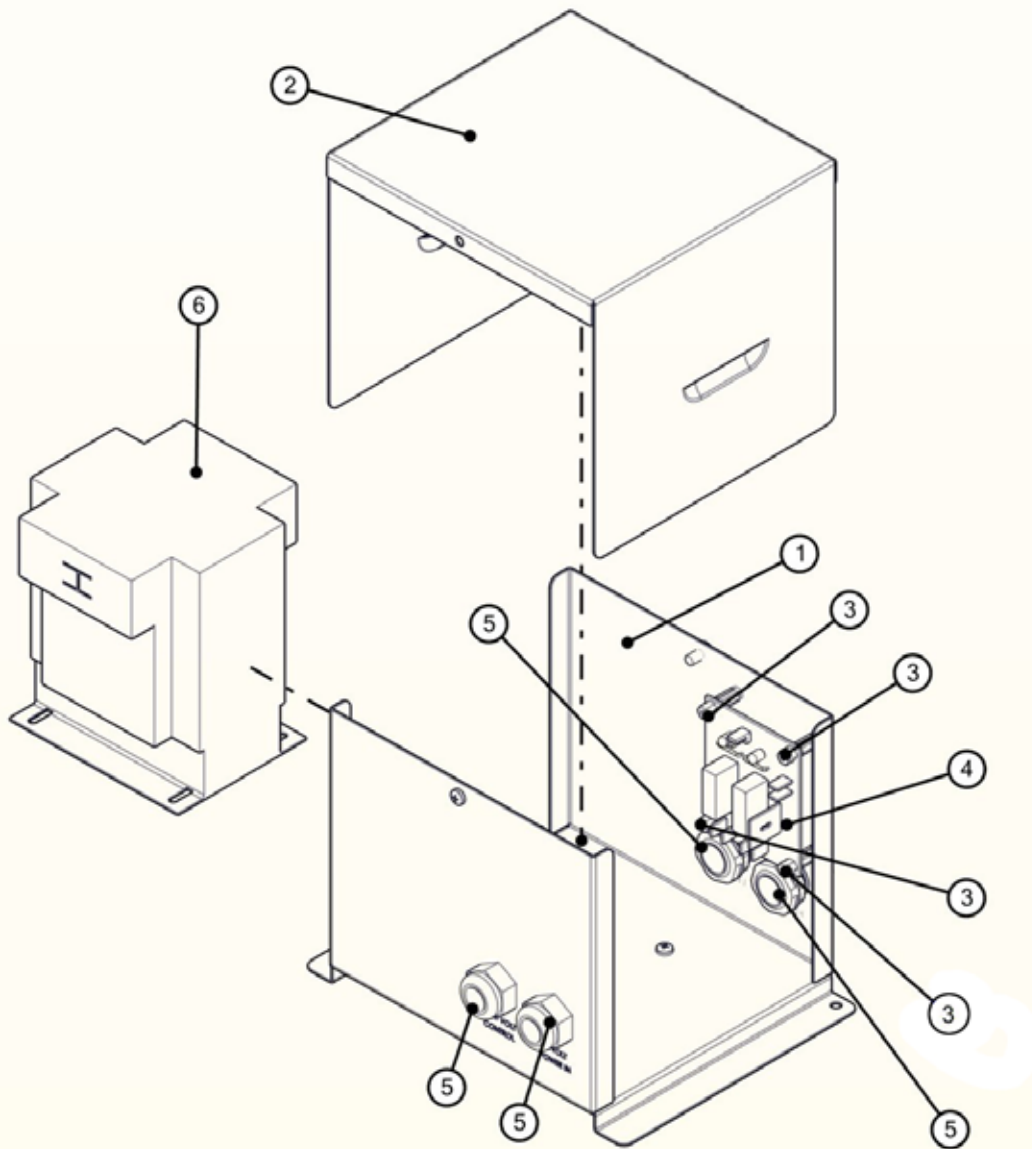

BOM ID	Name	DESCRIPTION (config)	Qty
1	1012989	LIFT BOX	1
2	1012990	ELEC. LIFT BOX COVER	1
3	SP-33707	SPACER, SUPPORT, NYL, 1.4"	4
4	BA-35163	24V LIFT RELAY BOARD	1
5	BU-3964	BUSHING, STRAIGHT, STRAIN RELIEF	4
6	TN-34272	TRANSFORMER, 120V/240V-24V, 150VA	1

SERVICE

CONTROL PANEL ASSEMBLY, ASF-60G – 5013197 SHOWN

ITEM	DESCRIPTION	P/N	QTY
1	Nut, #8-32 UNC KEPS ZP	NU-26526	8
2	1/2" Self Adhesive Gasket 3ft	GS-2019	1
3	Control, ASF-60, 10 Button	CC-34997	1
4	Weldment, Control Panel 15"	5013196	1
5	Bracket, Controller Support	1011993	1
6*	Cable Harness Control	CB-34999	1

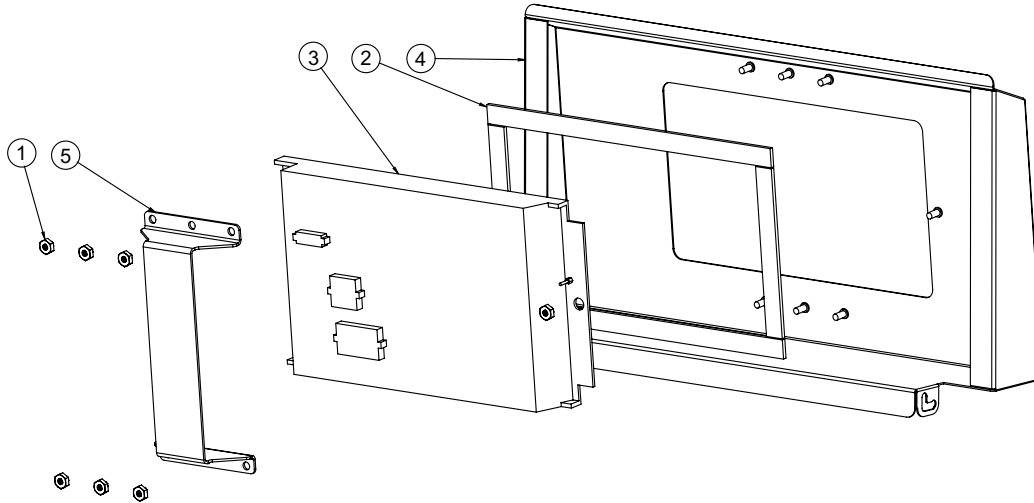

VALVE DRAIN ASSEMBLY, ASF-60B GAS BATTERY- REFERENCE DRAWING 5015568 SHOWN

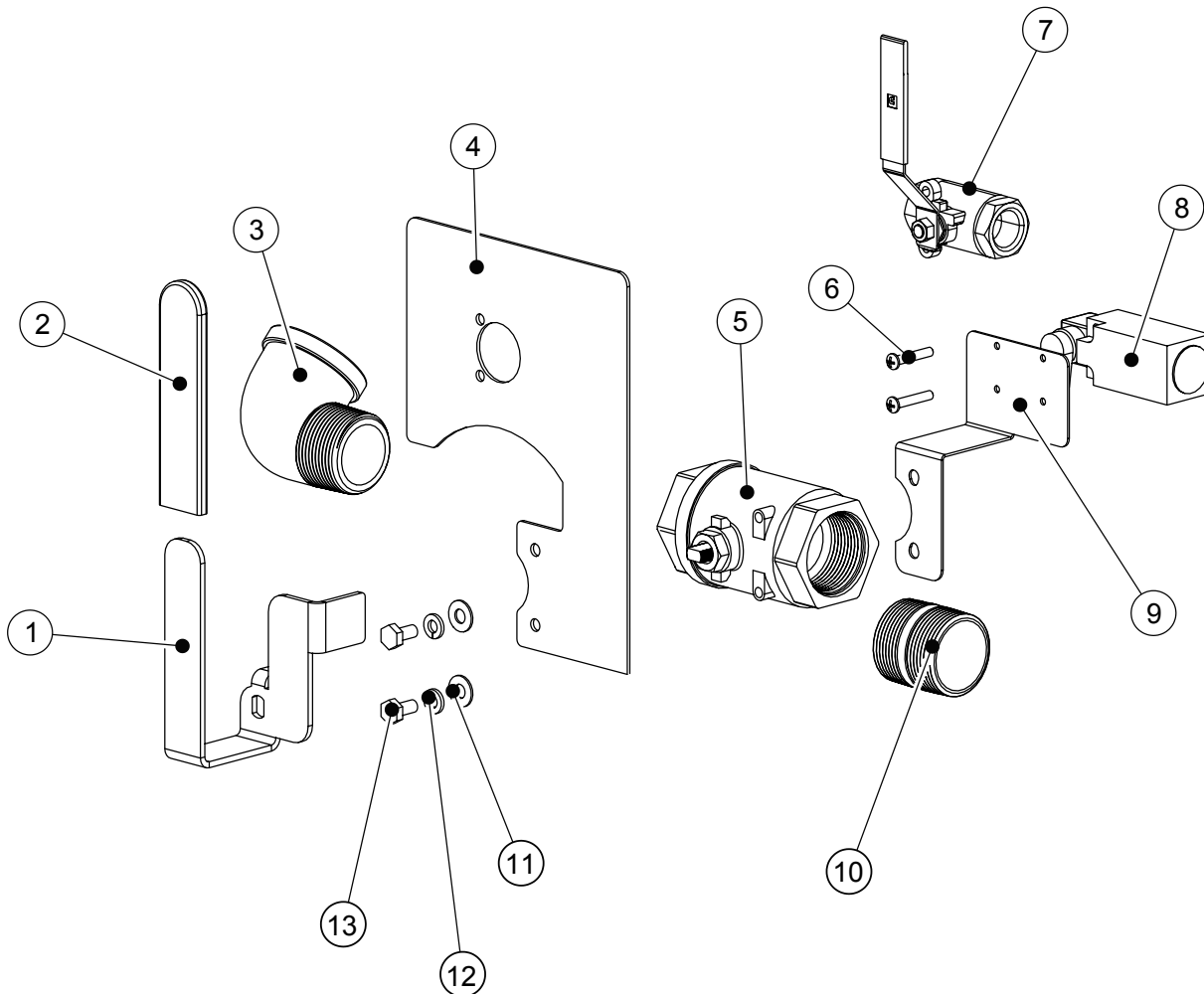

ITEM	PART NUMBER	DESCRIPTION	Qty
1	1013117	DRAIN VALVE HANDLE	1
2	SL-29640	HANDLE,VINYL,SLIP-ON	1
3	EB-35462	ELBOW,1-1/4" NPT STREET EL	1
4	1013723	BRACKET,VALVE MOUNT,ASF-60B	1
5	VA-28950	BALL VALVE-1 1/4" NPT	1
6	SC-2069	SCREW,8-32 X 1,NC PHILLIPS PAN	2
7	VA-28274	VALVE-BALL 1/2" NPT	1
8	SW-34246	LIMIT SWITCH	1
9	1013118	SWITCH BRACKET	1
10	NP-28949	NIPPLE-1 1/4" NPT x 1 5/8" LNG THRD BOTH ENDS	1
11	WS-22094	WASHER, 1/4", FLAT, 5/8 OD 18-8 SS	2
12	WS-2294	LOCK WASHER 1/4"	2
13	SC-22729	SCREW 1/4-20 x 1/2" HEX HEAD	2

FILTRATION ASSEMBLY, ASF-60B GAS BATTERY – REFERENCE DRAWING 5015569 SHOWN

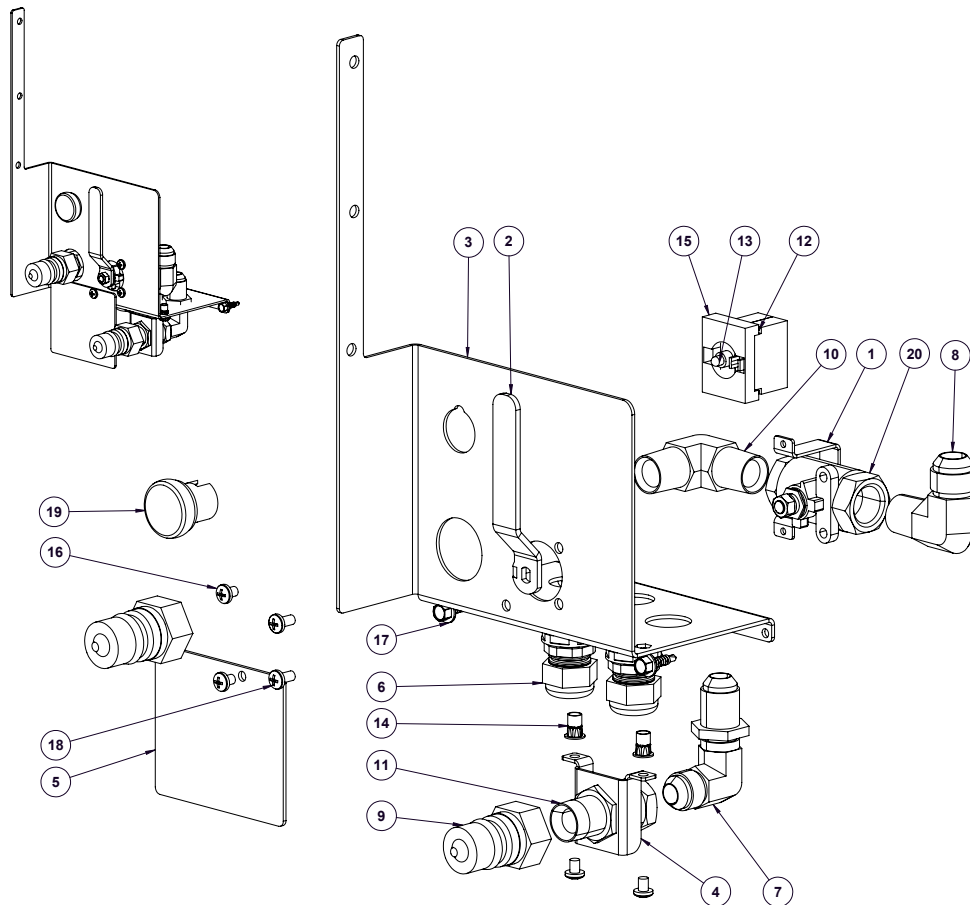

ITEM	P/N	DESCRIPTION	Qty	ITEM	P/N	DESCRIPTION	Qty
1	101191	Mounting Bracket	1	11	FT-28298	Fitting, Adapter 37° to NPTF	1
2	1011218	Valve, Handle for VA-28274	1	12	LI-34251	Switch, Push Button	1
3	1013770	Bracket, Pump Nozzle Mount	1	13	LI-34252	Light, Pump Push Button	1
4	1013958	Bracket, Mounting, 1 Hex Fitting	1	14	NU-29546	Nut, 10-32 Hex Insert	2
5	1013960	Bracket, Label Support	1	15	PA-27057	Plate, Light Mounting	1
6	BU-3964	Bushing, Straight, Strain Relief	2	16	SC-26791	Screw, #10-32 x 1/4 Pan	4
7	EB-28299	Elbow-Bulkhead 37° Flare Both Ends	1	17	SC-27384	Screw, #10-16 Self Drilling	2
8	EB-28688	Elbow, 37° x 1/2 NPTF	1	18	SC-28288	Screw, 10-24 x 3/8" Pan	2
9	FT-28008	Fitting, 1/2 NPT Quick Disconnect	2	19	SW-34240	Push Button Switch, Pump	1
10	FT-28250	Fintting, 1/2 MNPT Elbow	1	20	VA-28274	Valve Ball 1/2" NPT	1

TRANSPORTATION DAMAGE and CLAIMS



All Alto-Shaam equipment is sold F.O.B. shipping point, and when accepted by the carrier, such shipments become the property of the consignee.

Should damage occur in shipment, it is a matter between the carrier and the consignee. In such cases, the carrier is assumed to be responsible for the safe delivery of the merchandise, unless negligence can be established on the part of the shipper.

1. Make an immediate inspection while the equipment is still in the truck or immediately after it is moved to the receiving area. Do not wait until after the material is moved to a storage area.
2. Do not sign a delivery receipt or a freight bill until you have made a proper count and inspection of all merchandise received.
3. Note all damage to packages directly on the carrier's delivery receipt.
4. Make certain the driver signs this receipt. If he refuses to sign, make a notation of this refusal on the receipt.
5. If the driver refuses to allow inspection, write the following on the delivery receipt:
Driver refuses to allow inspection of containers for visible damage.
6. Telephone the carrier's office immediately upon finding damage, and request an inspection. Mail a written confirmation of the time, date, and the person called.
7. Save any packages and packing material for further inspection by the carrier.
8. Promptly file a written claim with the carrier and attach copies of all supporting paperwork.

We will continue our policy of assisting our customers in collecting claims which have been properly filed and actively pursued. We cannot, however, file any damage claims for you, assume the responsibility of any claims, or accept deductions in payment for such claims.

LIMITED WARRANTY

Alto-Shaam, Inc. warrants to the original purchaser only that any original part that is found to be defective in material or workmanship will, at Alto-Shaam's option, subject to provisions hereinafter stated, be replaced with a new or rebuilt part.

The parts warranty period is as follows:

For the refrigeration compressor on Alto-Shaam Quickchillers™, five (5) years from the date of installation.

For the heating element on Halo Heat® cooking and holding ovens, as long as the original purchaser owns the oven. This excludes holding only equipment.

For all other parts, one (1) year from the date of installation or fifteen (15) months from the shipping date, whichever occurs first.

The labor warranty period is one (1) year from the date of installation or fifteen (15) months from the shipping date, whichever occurs first.

Alto-Shaam will bear normal labor charges performed during standard business hours, excluding overtime, holiday rates or any additional fees.

To be valid, a warranty claim must be asserted during the applicable warranty period. This warranty is not transferable.

THIS WARRANTY DOES NOT APPLY TO:

1. Calibration.
2. Replacement of light bulbs, door gaskets, and/or the replacement of glass due to damage of any kind.
3. Equipment damage caused by accident, shipping, improper installation or alteration.
4. Equipment used under conditions of abuse, misuse, carelessness or abnormal conditions, including but not limited to, equipment subjected to harsh or inappropriate chemicals, including but not limited to, compounds containing chloride or quaternary salts, poor water quality, or equipment with missing or altered serial numbers.
5. Damage incurred as a direct result of poor water quality, inadequate maintenance of steam generators and/or surfaces affected by water quality. Water quality and required maintenance of steam generating equipment is the responsibility of the owner/operator.
6. Damage caused by use of any cleaning agent other than Alto-Shaam's Combitherm® Cleaner, including but not limited to damage due to chlorine or other harmful chemicals. **Use of Alto-Shaam's Combitherm® Cleaner on Combitherm® ovens is highly recommended.**
7. Any losses or damage resulting from malfunction, including loss of product, food product, revenue, or consequential or incidental damages of any kind.
8. Equipment modified in any manner from original model, substitution of parts other than factory authorized parts, removal of any parts including legs, or addition of any parts.

This warranty is exclusive and is in lieu of all other warranties, express or implied, including the implied warranties of merchantability and fitness for a particular purpose. In no event shall Alto-Shaam be liable for loss of use, loss of revenue or profit, or loss of product, or for any indirect, special, incidental, or consequential damages. No person except an officer of Alto-Shaam, Inc. is authorized to modify this warranty or to incur on behalf of Alto-Shaam any other obligation or liability in connection with Alto-Shaam equipment.



Effective November 1, 2011

RECORD THE MODEL AND SERIAL NUMBER OF THE APPLIANCE FOR EASY REFERENCE.

ALWAYS REFER TO BOTH MODEL AND SERIAL NUMBER IN ANY CONTACT WITH ALTO-SHAAM REGARDING THIS APPLIANCE.

Model: _____ Date Installed: _____
Voltage: _____ Purchased From: _____
Serial Number: _____

W164 N9221 Water Street • P.O. Box 450 • Menomonee Falls, Wisconsin 53052-0450 • U.S.A.

PHONE: 262.251.3800 • 800.558-8744 USA/CANADA FAX: 262.251.7067 • 800.329.8744 U.S.A. ONLY

www.alto-shaam.com

PRINTED IN U.S.A.