



**Models:
AR-7E**

- **INSTALLATION**
- **OPERATION**
- **MAINTENANCE**

W164 N9221 Water Street • P.O. Box 450
Menomonee Falls, Wisconsin 53052-0450 U.S.A.

PHONE: 262.251.3800 • 800.558.8744 U.S.A. / CANADA
FAX: 262.251.7067 • 800.329.8744 U.S.A. ONLY
www.alto-shaam.com



Consult instructions for
operation and use.





Delivery 1
Unpacking 1
Safety Procedures and Precautions 2

Installation

Site Installation 3
Leveling 3
Clearance Requirements 3
Sound Pressure Levels 3
Dimension Drawings 4
Product Capacity 4
Electrical Connection 5
Stacking Combinations & Instructions 6-7
Drip Tray Installation 8
Options & Accessories 8

Operating Instructions

Control Identification 9
Cooking Procedures - Quick Reference 10
Cooking Instructions 11
Hold Only Instructions 12
Additional Browning Feature 13
Preset Menu Key Option 14-15
Product Loading 16-17
Grease Collection 18-19

Care and Cleaning

Cleaning and Preventative Maintenance 20
Protecting Stainless Steel Surfaces 20
Cleaning Agents 20
Cleaning Materials 20
Equipment Care 21
Clean Daily 21
Daily Gasket Cleaning 22
Clean Convection Box 22
Check Overall Condition 22

Service

Troubleshooting Guide 23
Bulb Replacement Instructions 24
Final Floor 25
Final Floor Parts List 26-27
Full Assembly & Door Assembly 28
Full Assembly & Door Assembly Parts Lists 29
Interior View 30
Electrical Service 31
Replacement of Glass Door 32
Stainless Steel Back Panel 33
Grease Collection Unit 34

Wire Diagrams

Always refer to the wire diagram(s) included with the unit for most current version.

Warranty

Transportation Damage and Claims Back Cover
Limited Warranty Back Cover

Delivery

This Alto-Shaam appliance has been thoroughly tested and inspected to ensure only the highest quality unit is provided. Upon receipt, check for any possible shipping damage and report it at once to the delivering carrier. *See Transportation Damage and Claims section located in this manual.*

This appliance, complete with unattached items and accessories, may be delivered in one or more packages. Ensure all standard items and options have been received with each model as ordered.

Save all the information packed with the appliance. Register online at www.alto-shaam.com to ensure prompt service in the event of a warranty parts and labor claim.

This manual must be read and understood by all people using or installing the equipment model. Contact the Alto-Shaam Service Department if you have any questions concerning installation, operation, or maintenance.

1-800-558-8744; servicedept@alto-shaam.com

The serial number is required for all inquiries. Always include both model and serial number(s) in any correspondence regarding the appliance.

Model: _____

Serial number: _____

Purchased from: _____

Date installed: _____ Voltage: _____



CAUTION



Appliance and accessories may be heavy. To prevent serious injury, always use a sufficient number of trained and experienced workers when moving or leveling appliance and handling accessories.

Unpacking

- Carefully remove the appliance from the carton or crate.

NOTICE: Do not discard the carton and other packaging material until you have inspected the unit for hidden damage and tested it for proper operation.



- Read all instructions in this manual carefully before installing this appliance, using the appliance or performing routine maintenance. Following procedures other than those indicated in this guide to use and clean the appliance is considered inappropriate and may cause damage, injury or fatal accidents, in addition to invalidating the guarantee and relieving Alto-Shaam of all liability.
- DO NOT DISCARD THIS MANUAL.** This manual is considered part of the appliance and is provided for the owner or manager of the business and for training personnel. *Additional manuals are available from Alto-Shaam.*
- Remove all protective plastic film, packaging materials, and accessories from the appliance before connecting electrical power. Store any accessories in a convenient place for future use.

ENVIRONMENTAL CONDITIONS

- Operational Environmental Conditions
- Unit must acclimate to room temperature of the environment in which it is placed. 24 hours is recommended.
- Ambient temperature range of 60°F to 110°F (16°C to 43°C).
- Relative humidity of less than 95% non-condensation.
- Atmospheric pressure range of 50KPa to 106KPa.

- This appliance is intended to cook, hold or process foods for the purpose of human consumption. No other use for this appliance is authorized and is therefore considered dangerous. The appliance must not be used to cook food containing flammable materials (such as food with alcohol). Substances with a low flash point can ignite spontaneously and cause a fire.
- This appliance is intended for use in commercial establishments where all operators are familiar with the purpose, limitations, and associated hazards of this appliance. Operating instructions and warnings must be read and understood by all operators and users. We recommend regular training of your staff to avoid the risk of accident or damage to the unit. Operators must also receive regular safety instructions.
- Any trouble shooting guides, component views, and parts lists included in this manual are for general reference only and are intended for use by qualified and trained technicians.
- This manual should be considered a permanent part of this appliance. This manual and all supplied instructions, diagrams, schematics, parts lists, notices, and labels must remain with the appliance if the item is sold or moved to another location.

Knowledge of proper procedures is essential to the safe operation of electrically and/or gas energized equipment. The following signal words and symbols may be used throughout this manual.

DANGER

Indicates a hazardous situation that, if not avoided, will result in death or serious injury.

WARNING

Indicates a hazardous situation that, if not avoided, could result in death or serious injury.

CAUTION

Indicates a hazardous situation that, if not avoided, could result in minor or moderate injury.

NOTICE: Indicates information considered important, but not hazard-related (e.g., messages relating to property damage).

NOTICE:



For equipment delivered for use in any location regulated by the following directive: 2012/95/EC WEEE

DO NOT dispose of electrical or electronic equipment with other municipal waste.

SITE INSTALLATION

WARNING



Improper installation, alteration, adjustment, service, cleaning, or maintenance could result in property damage, severe injury, or death.

Read and understand the installation, operating and maintenance instructions thoroughly before installing, servicing, or operating this equipment.

In order to maintain established National Sanitation Foundation standards, all counter-mounted models must be sealed to the counter with a R.T.V. or silastic meeting N.S.F. requirements or have 6" (152mm) unobstructed clearance at the back and sides of the unit.

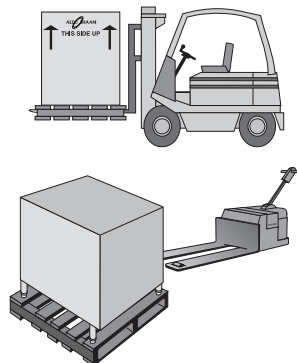

1. The appliance must be installed on a non-combustible, level surface.
2. **DO NOT** install this appliance in any area where it may be affected by any adverse conditions such as steam, grease, dripping water, high temperatures, or any other severely adverse conditions.
3. For both safety and convenience, the rotisserie must be installed in a location to provide easy access to the controls and should be positioned at a safe and convenient height to provide easy loading and unloading of hot products.
4. This appliance must be kept free and clear of any obstructions blocking access for maintenance or service.
5. A rotisserie can be stacked with another rotisserie oven or stacked on top of a matching holding cabinet. Complete stacking instructions are located in this manual.

A number of adjustments are associated with initial installation and start-up. It is important that these adjustments be conducted by a qualified service technician. Installation and start-up adjustments are the responsibility of the dealer or user. These adjustments include but are not limited to thermostat calibration, door adjustment, leveling, electrical hook-up and installation of optional casters or legs.

CAUTION



To prevent **personal injury** or **property damage**:

Always use hand protection when operating this appliance to avoid burns. Metal parts of this equipment become extremely hot when in operation.

WARNING



To prevent personal injury, death or property damage:

Do not store or use gasoline or other flammable vapors or liquids in the vicinity of this or any other appliance.

CAUTION



Appliance and accessories may be heavy. To prevent serious injury, always use a sufficient number of trained and experienced workers when moving or leveling appliance and handling accessories.

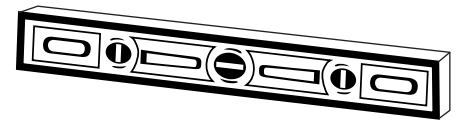

LEVELING

Level the appliance from side-to-side and front-to-back with the use of a spirit level.

We recommend checking the level periodically to make certain the floor has not shifted nor the appliance moved.

NOTE: Failure to properly level this appliance can cause improper function.

MINIMUM CLEARANCE REQUIREMENTS

A 6" (152mm) minimum clearance must be allowed at the back and both sides of the unit. Warranty will become null and void if these directions are not followed.

Sound Pressure Measurement

Microphone position	Sound pressure level dBA	
	Without hood system operating	With hood system operating
Front	69	71
Right Side	64.3	67
Left Side	64.3	69
Rear	64.7	68

INSTALLATION

SITE INSTALLATION

DOUBLE PANE CURVED GLASS DOOR

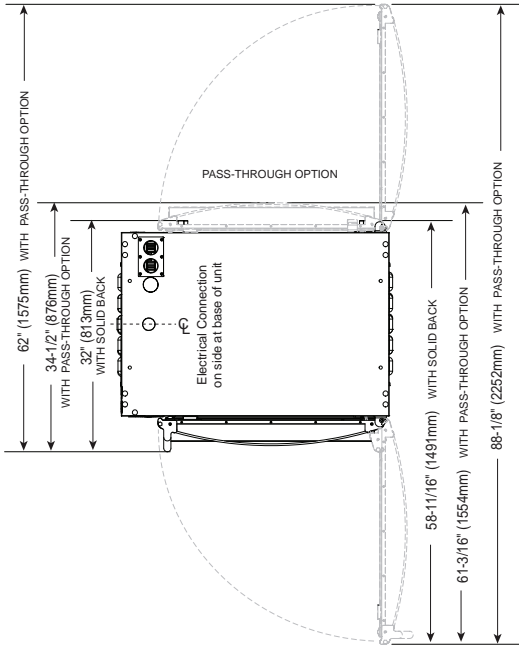

SINGLE PANE FLAT GLASS DOOR

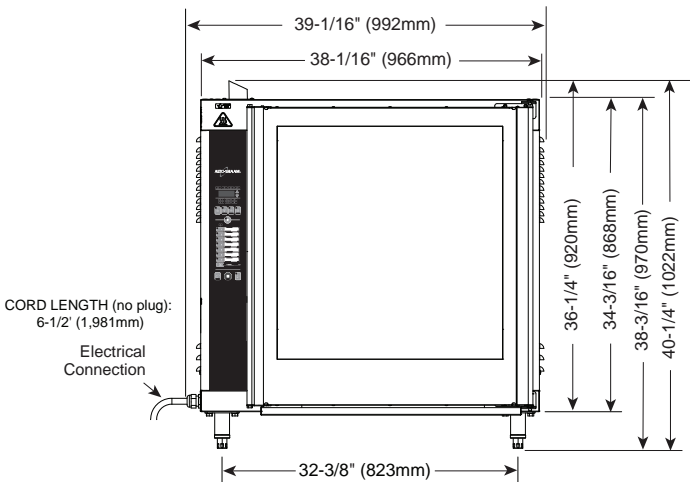
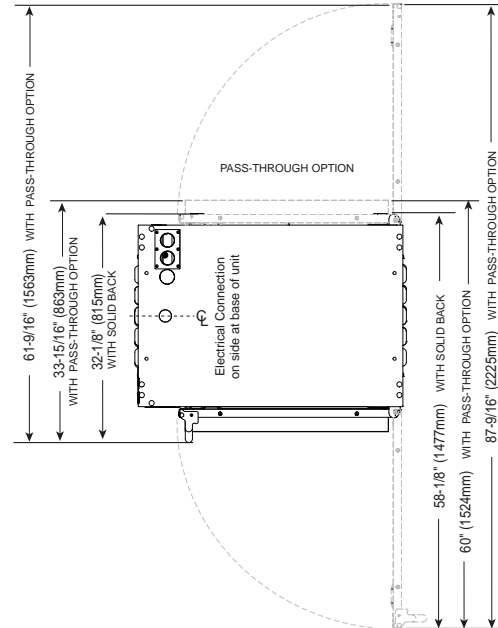

FRONT VIEW

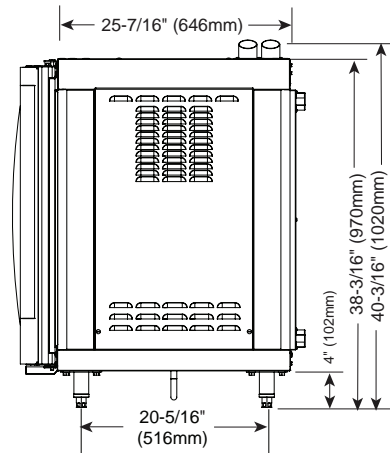

SIDE VIEW - SOLID BACK

WEIGHT

Net: 361 lb (164 kg)

PRODUCT PAN CAPACITY

98 lb (44 kg) MAXIMUM

ANGLED SPITS (STANDARD): (UP TO 7 SPITS CAN BE USED)
 Up to twenty-one (21) 3-1/2 lb chickens (1,6 kg)
 Up to twenty-eight (28) 2-1/2 to 3 lb chickens (1,1 to 1,4 kg)

PIERCING SPITS (OPTIONAL): (UP TO 7 SPITS CAN BE USED)
 Up to twenty-eight (28) 2-1/2 to 3-1/2 lb chickens (1,1 to 1,6 kg)



TURKEY SPIT (OPTIONAL): (UP TO 3 SPITS CAN BE USED) One (1) Turkey up to 25 lb (11 kg) on each spit

INSTALLATION

ELECTRICAL CONNECTION

The appliance must be installed by a qualified service technician. The oven must be properly grounded in accordance with the National Electrical Code and applicable local codes.

WARNING

All electrical connections must be made by a qualified and trained service technician in accordance with applicable electrical codes.

This appliance must be adequately grounded in accordance with local electrical codes or, in the absence of local codes, with the current edition of the National Electrical Code ANSI/NFPA No. 70. In Canada, all electrical connections are to be made in accordance with CSA C22.1, Canadian Electrical Code Part 1 or local codes.

CE-approved appliances include an equal-potential-bonding terminal marked with the symbol shown on the left.

Provisions for earthing are to be made in accordance with IEC:2010 60335-1 section 27 or local codes.

Plug the unit into a properly grounded receptacle ONLY, positioning the unit so that the plug is easily accessible in case of an emergency. Arcing will occur when connecting or disconnecting the unit unless all controls are in the "OFF" position.

Proper receptacle or outlet configuration or permanent wiring for this unit must be installed by a licensed electrician in accordance with applicable local electrical codes.

After wiring and power connection has been completed, turn the main power switch to the "ON" position. The main power switch can be left "ON" for daily use, but should be turned "OFF" when cleaning or performing maintenance or repairs to the rotisserie.

"WARNING" RISK OF FIRE!

Use a UL listed grounding type plug rated 250 Volts, 50 Amperes, 1 Phase, 3 wire for single phase units and 250 V, 50 A, 3 Phase, 4 wire for three phase units. Plug to be selected and installed only by qualified service personnel. Individual conductors are marked L1, L2, L3 when applicable, N when applicable, and G.

WARNING



Appliances without a cord provided by the factory must be equipped with a cord of sufficient length to permit the appliance to be moved for cleaning.

Always use the correct AWG wire size based on the electrical requirements for the appliance.

ELECTRICAL



VOLTAGE	PHASE	CYCLE/HZ	AMPS	KW
208	1	60	40.0	8.3
240	1	60	38.0	8.8
208	3	60	33.0/ph	8.3
240	3	60	32.0/ph	8.8
380-415	3	50/60	24.0/ph	8.8
380	3	50/60	22.0/ph	7.4
415	3	50/60	24.0/ph	8.8
				NO CORD NO PLUG

Wire diagrams are located in the inside access panel of the unit.

REGARDING INTERNATIONAL STANDARD UNITS:

If the unit is not equipped with flexible cord with plug, an all-pole country approved disconnection device which has a contact separation of at least 3mm in all poles must be incorporated in the fixed wiring for disconnection. When using a cord without a plug, the green/yellow conductor shall be connected to the terminal which is marked with the ground symbol. If a plug is used, the socket outlet must be easily accessible. If the power cord needs replacement, use a similar one obtained from the distributor.

WARNING

For CE approved appliances: To prevent an electrical shock hazard between the appliance and other appliances or metal parts in close vicinity, an equalization-bonding stud is provided. An equalization-bonding lead must be connected to this stud and the other appliances/metal parts to provide sufficient protection against potential difference.

The terminal is marked with the following symbol. Provisions for earthing are to be made in accordance with IEC:2010 60335-1 section 27 or local codes.

Power Cord Connection: The side connection is recommended for all applications. If a bottom connection is necessary for countertop ovens, user will need to provide a cutout in the top of the counter to allow the cord to hang freely without crimping.

Hard wired models:

Hard wired models must be equipped with a country certified external all-pole disconnection switch with sufficient contact separation.

If a power cord is used for the connection of the product an oil resistant cord like H05RN or H07RN or equivalent must be used. Ground fault or residual current protection device must accommodate a leakage current that may exceed 10mA.

NOTICE: Where local codes and CE regulatory requirements apply, appliances must be connected to an electrical circuit that is protected by an external GFCI outlet.

CAUTION



Power source must match voltage identified on appliance rating tag. The rating tag provides essential technical information required for any appliance installation, maintenance or repairs. Do not remove, damage or modify the rating tag.

INSTALLATION

STACKING COMBINATIONS & INSTALLATION REQUIREMENTS

STACKING COMBINATIONS (FACTORY INSTALLED)

AR-7E rotisserie over AR-7E rotisserie

Requires 6" (152mm) leg assembly [5001414](#) or 5" (127mm) casters [4007](#) and stacking assembly (5009981, 5009982, 5009983, 5010355, 5010356, or 5010357 - depending on voltage and door swing - see pg 8) for applications within the United States. Applications outside the U.S. requires 6" (152mm) legs with flanged feet [5001761](#) bolted to the floor. [OVERALL HEIGHT: 76-7/8" (1953mm)]

AR-7E rotisserie over AR-7H companion holding cabinet Requires 6" (152mm) leg assembly [5001414](#) or 5" (127mm) casters [4007](#) and stacking assembly ([5008787](#), [5008948](#) or [5008922](#) - depending on voltage - see pg 8) for applications within the United States. Applications outside the U.S. requires 6" (152mm) legs with flanged feet [5001761](#) bolted to the floor. [OVERALL HEIGHT: 76-7/8" (1953mm)]

AR-7E rotisserie over ASC-4E convection oven Requires 6" (152mm) legs with flanged feet [5003795](#) bolted to the floor. [OVERALL HEIGHT: 79-5/8" (2022mm)]

STACKING INSTRUCTIONS

A rotisserie can be stacked with another rotisserie or can be stacked on top of a matching holding cabinet or a convection oven.

Stacking hardware is required for all stacking combinations (SEE ABOVE AND THE OPTIONS LIST ON PG 8 FOR MORE INFORMATION).

All fastening holes have been pre-punched. The stacking combination also requires the minimum clearance of 6" (152mm) at the top, back and both sides.

NOTE: Do not remove corner panels. They are not shown in the drawing only to increase visibility of the interior components.

1. Remove the access panels of both units.

Remove power cord, strain relief bushing, and strain relief washer (drill out 2 rivets) from the rotisserie intended to be on the top. Discard power cord.

208-240V, 3PH - RH/LH DOOR SWING:

Remove power cord and strain relief bushing from the rotisserie intended to be on the top. Discard power cord.

380-415V - RH/LH DOOR SWING:

Remove strain relief bushing from the rotisserie intended to be on the top.

	CAUTION
MAKE CERTAIN TO FASTEN EACH OF THE FOUR HOLES	

	WARNING
To prevent SERIOUS INJURY, DEATH or PROPERTY DAMAGE: Stacking applications outside the U.S. require flanged feet and must be bolted to the floor.	

3. Attach cover plate (1010464) to cord hole with 2 rivets.
4. Remove any existing legs or casters from both of the rotisseries.
5. Review "stacking combinations & installation requirements" above, then attach support brackets and legs or casters to the rotisseries intended to be on the bottom with 1" (25mm) screws, washers, and lock washers.
6. Punch out the knock out holes A, B, C, & D.
7. Detach decorative exhaust by removing 6 screws from top panel of rotisserie intended to be on the bottom.
8. Remove 4 plugs (E) from top panel of rotisserie intended to be on the bottom.
9. Apply high temp silicone around perimeter of exhaust opening on the top panel of the rotisserie to be on bottom (F).
10. Carefully lift and place the upper unit into position aligning on the bottom unit.
11. Secure units together by inserting a hex head screw and a flat washer in each hole of the top unit and a flat washer, lock washer, and hex nut inside the bottom unit. Securely tighten all four screws.
12. Apply high-temp silicone to seal where the lower weldment attaches to the bottom panel (H).

STACKING INSTRUCTIONS (CONTINUED)

13. Inside the left side of the upper unit, install the upper exhaust weldment routing it out the top of the upper unit and then mating it with the lower exhaust weldment using the rubber hose and hose clamps.

14. 208-240V, 1PH - RH/LH DOOR SWING:

Reattach strain relief bushing and strain relief washer with rivets to upper unit at knock out holes A & B.

208-240V, 3PH & 380-415V - RH/LH DOOR SWING:

Reattach strain relief bushing to upper unit at knock out holes A & B.

15. 208-240V, 1PH - RH/LH DOOR SWING:

Attach additional strain relief bushing and strain relief washer with rivets to lower unit at knock out hole C.

208-240V, 3PH & 380-415V - RH/LH DOOR SWING:

Attach additional strain relief bushing to lower unit at knock out hole C.

16. 208-240V, 1PH & 3PH - RH/LH DOOR SWING:

Attach the 14' (4,267 mm) power cord to the terminal block of upper unit using ring connectors.

380-415V - RH/LH DOOR SWING:

No power cord supplied, proceed to step 17.

17. Replace the side panels on both units.

AR-7E OVER AR-7E STACKING ASSEMBLY (5009981 SHOWN)

ITEM	PART NO.	DESCRIPTION	QTY
1	1002389	WASHER, STRAIN RELIEF	2
2	1010092	BRACKET, SUPPORT, BASE	4
3	1010464	PLATE, COVER, CORD HOLE	1
4	5009985	WELDMENT, EXHAUST, LOWER	1
5	5009987	WELDMENT, EXHAUST, UPPER (RH)	1
	5010061*	WELDMENT, EXHAUST, UPPER (LH)	1
6	BU-33505	BUSHING, STRAIN RELIEF, INT	208-240V, 1PH 1
	BU-33948*	BUSHING, STRAIN RELIEF, 18mm-25mm	208-240V, 3PH 1
			380-415V 1
7	CD-33841	CORD, 14' (4,267mm)	208-240V, 1PH 1
	CD-3987*	CORD, 14' (4,267mm)	208-240V, 3PH 1
8	CL-22234	CLAMP, WORM GEAR, 40-60 HOSE	2
9	CR-3801*	CONNECTOR, RING 10mm	3
10	HO-27883	HOSE, 2" I.D. FDA; 0.25' (76mm)	1
11	NU-2437	NUT, 1/4-20 HEX S/S	4
12	RI-2100	RIVET, BLIND, #44, S/S	6
13	SC-2191	SCREW, HEX HEAD, 5/16-18 x 1" LONG	16
14	SC-27385	SCREW, 1/4-20 x 3/4" LG HEX HEAD	4
15	WS-22094	WASHER, 1/4", FLAT, 5/8 OD 18-8 SS	8
16	WS-22095	WASHER, 3/8" ID, 1" OD, FLAT 18-8 SS	16
17	WS-2294	LOCK WASHER 1/4"	4
18	WS-2867	LOCK WASHER 5/16"	16

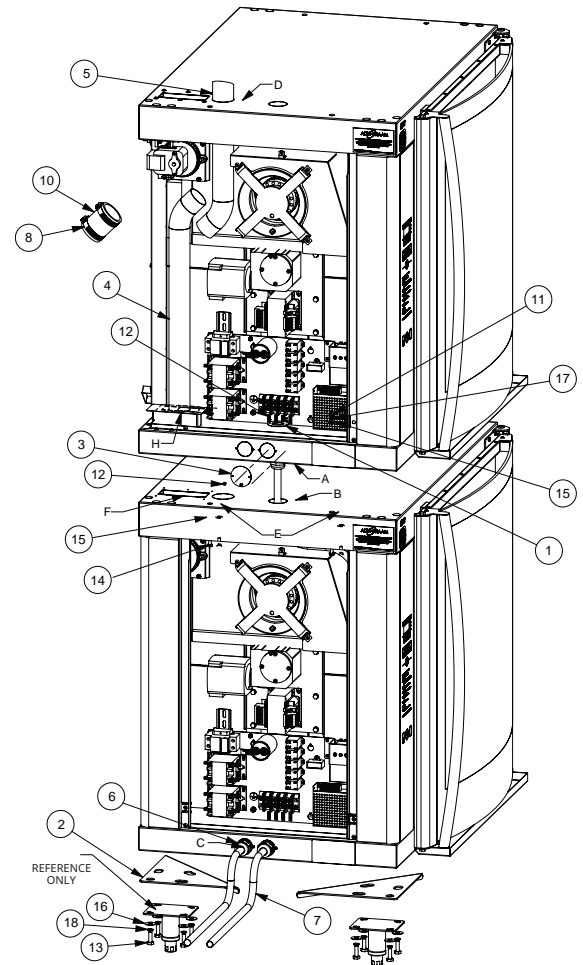

*NOT SHOWN

INSTALLATION

DRIP TRAY INSTALLATION

Attach tray using two carriage bolts (A) in base panel. Lift tray up and away to remove.

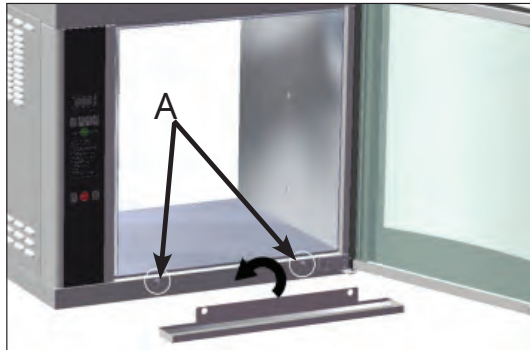

GREASE COLLECTION UNIT



OPTIONS & ACCESSORIES

DESCRIPTION	PART NO.
CASTERS, 5" (127mm)	2 RIGID, 2 SWIVEL W/ BRAKE 4007
DOOR HANDLE	NON-CONTROL SIDE HD-26900
DOOR OPTIONS	SINGLE PANE FLAT GLASS, CONTROL SIDE (RH UNITS) 5009591 SINGLE PANE FLAT GLASS, NON-CONTROL SIDE (RH UNITS) 5009815
DRIP PAN, STAINLESS STEEL	WITHOUT DRAIN 1001976
FEET, RUBBER, 2" (51mm) FOR COUNTER TOP UNITS ONLY (NOT AVAILABLE ON MODELS BUILT FOR US OR CANADA)	CE ONLY 5001614
GREASE COLLECTION UNIT	NOT AVAILABLE ON STACKED UNITS 5012800
LEGS	ASSEMBLY, 6" (152mm) 5001414 ASSEMBLY, FLANGED FEET, 6" (152mm) (REQUIRED FOR STACKING UNITS) 5001761
MULTI-PURPOSE WIRE BASKET (.50 DIAMETER PIN)	BS-26019
SPITS	ANGLED SPIT, STAINLESS STEEL (7 STANDARD WITH UNIT) SI-25934 PIERCING SPIT, STAINLESS STEEL SI-25729 TURKEY SPIT, STAINLESS STEEL 5011681 ANGLED SPIT, TEFLON COATED 5001335
STACKING ASSEMBLY (FACTORY INSTALLED)	
AR-7E OVER AR-7E (RIGHT-HAND)	(208-240V, 1PH) 5009981 (208-240V, 3PH) 5009982 (380-415V) 5009983
AR-7E OVER AR-7E (LEFT-HAND)	(208-240V, 1PH) 5010355 (208-240V, 3PH) 5010356 (380-415V) 5010357
AR-7E OVER AR-7H	(208-240V, 1PH) 5008787 (208-240V, 3PH) 5008948 (380-415V) 5008922
AR-7E OVER ASC-4E	5013873
STANDS (H x W x D)	AR-7E W/ SHELF, 35-15/16" x 39-3/16" x 27-1/2" (912mm x 995mm x 700mm) FR-26550 AR-7E OVER 750-S, 36" x 39-3/16" x 27-9/16" (914mm x 995mm x 700mm) 5002058
NON-STICK COATED ACCESSORY - COMMERCIAL GRADE	5001302
COMMERCIAL GRADE, INCLUDES DISKS, DRIP TRAY AND 7 ANGLED SPITS	

OPERATING INSTRUCTIONS

ROTISSERIE CONTROL IDENTIFICATION

ALTO-SHAAM®

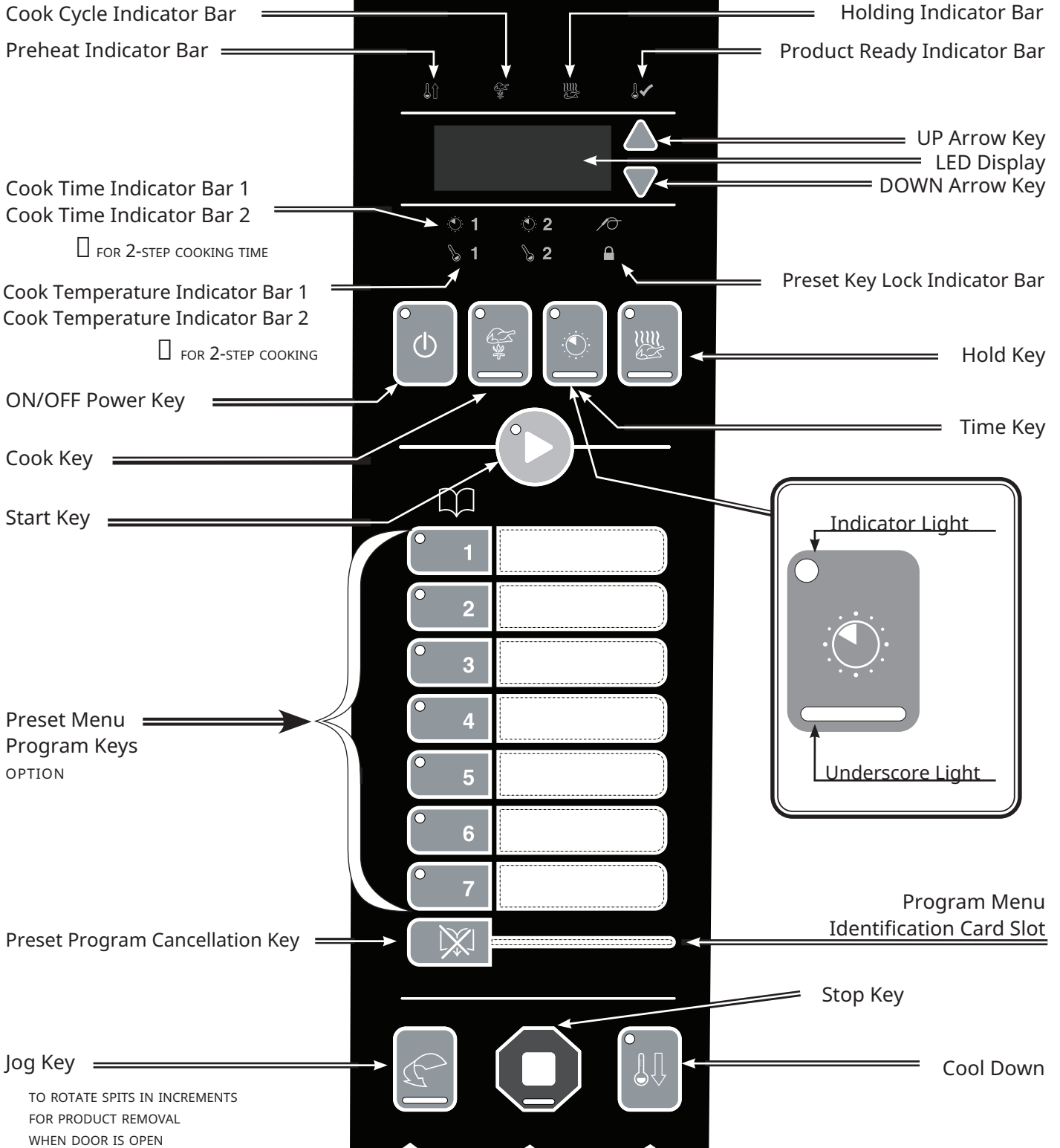

QUICK REFERENCE OPERATION

ALLOW THE ROTISSERIE TO PREHEAT
LOAD PRODUCT WHEN OVEN BEEPS AT REGULAR INTERVALS AND THE
START KEY AND READY INDICATOR BEGIN FLASHING

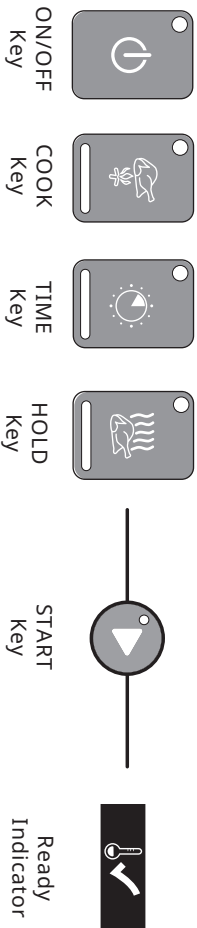

1. Press the ON/OFF key.
2. Press and set the COOK key.
3. Press and set the COOK key for 2-step cooking.
4. Press and set the TIME key.
5. Press and set the TIME key for 2-step cooking.
6. Press and set the HOLD key.
7. Press the HOLD key again to add browning time.
8. When preheated: Load product & press start.

ITEM	CHICKEN, HALVES OR PIECES	CHICKEN, WHOLE	TURKEY BREAST	PORK RIBS	PORK LOIN, BONELESS	LAMB LEG, BONELESS
SIZE OF MEAT	2-1/2 to 3 lb (1,1 to 1,4 kg)	2-1/2 to 3 lb (1,1 to 1,4 kg)	5-1/2 lb (2,5 kg)	2-3/4 down	5 to 7 lb (2,3 to 3,2 kg)	8 to 11 lb (4 to 5 kg)
CAPACITY PER SPIT/ BASKET	8 pieces	3-4 chickens	1 turkey breast	2 full slabs	1 to 2 pork loins	1 lamb leg
SUGGESTED SPIT/ BASKET	BASKET	STANDARD OR PIERCING SPIT	BASKET OR PIERCING	BASKET	BASKET	BASKET OR PIERCING
COOK TEMP 1	425°F (218°C)	400°F (204°C)	250°F (121°C)	250°F (121°C)	250°F (121°C)	250°F (121°C)
COOK TEMP 2	NOT REQUIRED	NOT REQUIRED	400°F (204°C)	375°F (191°C)	350°F (177°C)	350°F (177°C)
COOK TIME 1	30 minutes (20 min for long-term holding)	45 minutes	1-1/2 hours	40 minutes	1 hour	1-1/2 hours
COOK TIME 2	NOT REQUIRED	NOT REQUIRED	15 minutes	5 minutes	15 minutes	15 minutes
HOLD TEMP	160°F (71°C)	160°F (71°C)	165°F (74°C)	150°F (66°C)	160°F (71°C)	150°F (66°C) (medium doneness)
BROWNING TIME	NOT REQUIRED	5 minutes	NOT REQUIRED	15 minutes	NOT REQUIRED	15 minutes
FINAL INTERNAL TEMP	185°F (85°C)	185°F (85°C)	180°F (82°C)	160° to 170°F (71° to 77°C)	155° to 165°F (68° to 74°C)	145° to 150°F (63° to 66°C)

OPERATING INSTRUCTIONS

COOKING INSTRUCTIONS



Press the ON/OFF key.

1. The on/off indicator light will illuminate.
2. The display will show the last set holding temperature.
3. The hold indicator will illuminate.
4. The rotisserie will begin to preheat to the holding temperature shown in the display.



Press the COOK key.

1. The COOK and the TIME underscore lights will alternately illuminate.
2. The display will indicate the last set cooking temperature when the COOK underscore light is illuminated.
3. The display will indicate the last set cooking time when the TIME underscore light is illuminated.
4. Cook temperature indicator bar will illuminate for:

COOK TEMPERATURE 1

5. If 2-step cooking is required **press the COOK key again** 
Cook temperature indicator bar will illuminate for:

COOK TEMPERATURE 2



To change the displayed temperature:

After pressing the COOK key, press the up and down arrow key when **COOK TEMPERATURE 1** or **COOK TEMPERATURE 2** is illuminated.



Press the TIME key.

1. The TIME underscore light will illuminate.
2. The display will indicate the last set cooking time when the TIME underscore light is illuminated.
3. The display will indicate the last set cooking temperature when the COOK underscore light is illuminated.

4. Time indicator bar will illuminate for:

TIME 1 

5. If 2-step cooking is required **press the TIME key again**

Time indicator bar will illuminate for:

TIME 2 

To change the displayed time:

After pressing the TIME key, press the up and down arrow key when **TIME 1** or **TIME 2** is illuminated.



Press the HOLD key.

1. The HOLD underscore light will illuminate. 2. The display will indicate the last set holding temperature.

To change the holding temperature:

After pressing the HOLD key, press the up and down arrow key when the HOLD underscore light is illuminated.



- Product programming can be considered complete after the holding temperature has been set or additional browning time can be added if desired.
- Automatic holding time will activate when the cooking cycle time and any additional browning time has elapsed and the **PRODUCT READY BAR** is illuminated. 
- The product will continue to cook as it decreases from the cooking temperature to the holding temperature. For best results, always allow for product temperature override.

To stop a cooking program early and continue to hold:



Press stop
The Rotisserie will stop



Press On/Off
The rotisserie will continue in the hold mode



Press Start
The rotisserie will begin to rotate and hold at the set temperature

OPERATING INSTRUCTIONS

HOLD ONLY INSTRUCTIONS

Hold with rotisserie can be set in the power on hold mode or if the operator wants to stop a cooking procedure but continue holding with rotisserie.



Press the ON/OFF key.

1. The on/off indicator light will illuminate.
2. The display will show the last set holding temperature.
3. The hold indicator will illuminate.
4. The rotisserie will begin to preheat to the holding temperature shown in the display.



Press the HOLD key.

1. The HOLD underscore light will illuminate.
2. The display will indicate the last set holding temperature.

To change the holding temperature:

After pressing the HOLD key, press the up and down arrow key when the HOLD underscore light is illuminated.

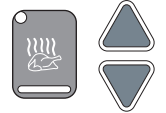

Press the START key.

The rotisserie will begin to rotate and hold at the set temperature

To stop a cooking program early and continue to hold:



Press Stop

The rotisserie will stop



Press On/Off

The rotisserie will continue in the hold mode



Press Start

The rotisserie will begin to rotate and hold at the set temperature

OPERATING INSTRUCTIONS

ADDITIONAL BROWNING FEATURE

The control allows the operator to set a specific period of time for additional browning between the end of the COOK TIME and the illumination of the PRODUCT READY BAR at the end of the cooking cycle. Browning time is to be added during initial product programming. 



Press the HOLD key.

1. The HOLD underscore light will illuminate.
2. The display will indicate the last browning time.

To change the browning time:

After pressing the HOLD key, press the up and down arrow key when the browning time appears in the display. **Note:** To disable the browning feature set the time to “:00”



AVERAGE BROWNING TIME FOR MOST PRODUCTS IS BETWEEN 5 AND 20 MINUTES

- If a browning time has been set, only the radiant heaters will operate.
- **NOTE:** The product will continue to cook as it decreases from the cooking temperature to the holding temperature. For best results, always allow for product temperature override.
- The PRODUCT READY BAR will illuminate at the end of the set browning time and the oven temperature will decrease to the set holding temperature in the automatic hold mode. 

THE ROTISSERIE WILL CONTINUE TO PREHEAT UNTIL THE COOK TEMPERATURE IS REACHED.

ALWAYS ALLOW THE ROTISSERIE TO PREHEAT TO THE FULL SET COOKING TEMPERATURE.

When fully preheated, the START key and the PRODUCT READY BAR will flash and the control will beep four times



LOAD PRODUCT PRESS START

- The spit motor will begin to rotate.
- The display will alternate between showing the set cook temperature and set cook time.

When the cooking time and any additional set browning time is complete, the PRODUCT READY BAR will illuminate to indicate the end of the cooking function.

▶ ▶ ▶ AUTOMATIC HOLDING TIME WILL ACTIVATE. ◀ ◀ ◀

- The display will alternate between the set holding temperature and the elapsed holding time since READY.

To stop a cooking program early and continue to hold:



Press Stop

The rotisserie will stop



Press On/Off

The rotisserie will continue in the hold mode



Press Start

The rotisserie will begin to rotate and hold at the set temperature

OPERATING INSTRUCTIONS

PRESET MENU KEY OPTION

The Alto-Shaam rotisserie provides the operator with the ability to set as many as seven cooking programs. Each cooking program can be preset to include all cooking and holding functions. Cooking programs are stored and recalled using the PRESET Keys labeled 1 through 7.

PROGRAMMING A COOKING PROGRAM:



With the rotisserie oven in the "OFF" position, determine the food product procedure to be programmed. Press and release control ON/OFF key. The oven will beep for one second and power to the unit will be indicated by an illuminated green indicator light located in the upper left corner of the ON/OFF key. The oven will begin operating in the hold mode. The amber hold indicator will be illuminated and the last set hold temperature will be displayed.

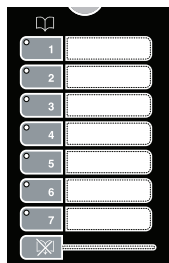

ENTER ALL COOKING AND HOLDING PARAMETERS FOR THE PRODUCT SELECTED AS INSTRUCTED ON THE PREVIOUS PAGE.

Select a number for the programmed product. Press and hold the selected PRESET number key until you hear an audible signal which will occur within 3 seconds. The number key program indicator light will illuminate. The programmed product is now stored in memory on the specific number key selected.

NOTE: The last PRESET Key programmed will be the oven cooking run sequence for the next product to be programmed. Settings can be manually changed for the next product and an alternate pre-programmed letter key selected.

TO COOK WITH PRESET MENU KEYS:

PRESS AND RELEASE CONTROL ON/OFF KEY.



- The control will beep and the green indicator light on the ON/OFF key will illuminate.
- The amber hold indicator will illuminate.
- The oven will begin operating in the hold mode.
- The previously set hold temperature will be displayed.
- The green indicator will illuminate on all programmed PRESET Keys.

PRESS DESIRED PRESET KEY (1 THROUGH 7)

- The Pre-Heat indicator will illuminate.
 - The rotisserie oven will automatically preheat to the cooking temperature programmed.
- The oven will beep when preheated and the preheat indicator will go out.
- Both the Ready and Start indicator lights will flash.
 - The set cook temperature will be maintained by the oven and appear in the display while in the ready/start mode.

NOTE: Presets cannot be modified once selected. If a modification is desired, the preset must be erased and re-saved.

LOAD THE PREPARED PRODUCT SPITS INSIDE OVEN AND CLOSE THE OVEN DOOR.

PRESS AND RELEASE THE START KEY.



NOTE: The rotisserie will beep 4 times when cooking is finished.

OPERATING INSTRUCTIONS

ATTENTION

After programming a specific product into memory on a preset key number, it is suggested the product be identified by inserting a label in the Program Menu Identification Card Slot.

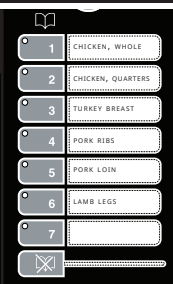

TO ERASE A PRESET

To erase a preset, the oven must be in either the power-up hold mode or in the preheat mode.

The oven cannot be in a cook or automatic hold.

When the oven is in the power-up hold mode or in the preheat mode, press and hold both the **CANCEL** key and the appropriate number **PRESET** key to be erased. The preset indicator light will go out once the preset is erased.



CANCEL key



preset indicator light

PRESET MENU LOCK AND UNLOCK

The preset menu keys can be locked at any time in order to prevent inadvertent or accidental setting changes.

To lock the preset keys, press the **UP ARROW** key along with the **ON/OFF** Key. The rotisserie will beep and the **preset lock indicator** will illuminate. Release all keys. The rotisserie presets are now locked.

To unlock the preset keys, press the **DOWN ARROW** key along with along with the **ON/OFF** Key. The rotisserie will beep twice and the preset lock indicator will extinguish. Release all keys. The preset keys are now unlocked and ready for programming.



preset lock indicator

FAHRENHEIT OR CELSIUS SELECTION

With the control off, **press and hold** the **UP ARROW** key for 2 seconds to display the current temperature scale. Toggle between °F and °C by pressing either the up or down arrow key while the temperature scale is displayed on the screen.

The new scale will save when the screen clears or the On/Off key is pressed.

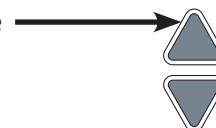

COOL DOWN

To cool down the unit:

- Press the Stop button
- Press the **COOL DOWN** key. The fan will turn on. The display will cycle between "Cool" and the internal cavity temperature.

NOTE: If the door is closed, the display will show "oPEn door" instead of "Cool".

- Press the **STOP** button again to cancel the cool down process.



WARNING



THE CONVECTION FAN CONTINUES TO ROTATE DURING THE COOL DOWN PROCESS. DO NOT OPEN THE PANEL WHILE COOLING DOWN THE ROTISSERIE OVEN.

OPERATING INSTRUCTIONS

PRODUCT LOADING

STANDARD SPITS

Each of the seven rotisserie spits includes two welded prongs on the square end and one welded, ridged prong on the tapered end. Insert the two-prong, square end into the two holes indicated on the disk assembly drive wheel in the drawing. Insert the tapered, ridged-prong end into the top hole indicated on the opposite side and maneuver until the ridge catches in the hole. After placing one spit into the oven, rotate the rotisserie using the jog button as shown to load every other position. Continue loading the spits one at a time. This is done to maintain balance within the rotisserie.

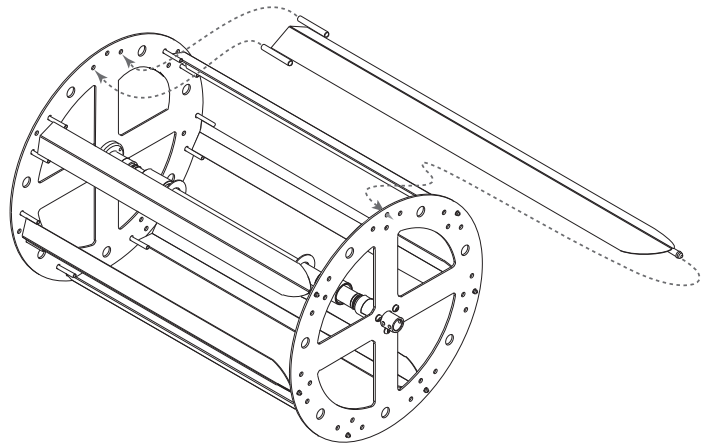

OPTIONAL SPITS/BASKETS

When optional spits are used, insert the spits in the drive wheel as indicated in the illustration.

When inserting the basket, put the smooth pin (A) end in first. When removing the basket, the machined pin (B) comes out first.

IMPORTANT NOTE:

When using a partial quantity of standard or optional spits, space the spits evenly as possible around the drive wheel to maintain balance and even rotation.

SPECIAL ATTENTION:

A combination of standard, piercing, and basket spits can be used at the same time but NOT in every spit insertion position. The use of a spit in every position will interfere with the free rotation of the baskets. Using a combination of spits can only be accomplished at significantly reduced rotisserie capacity.

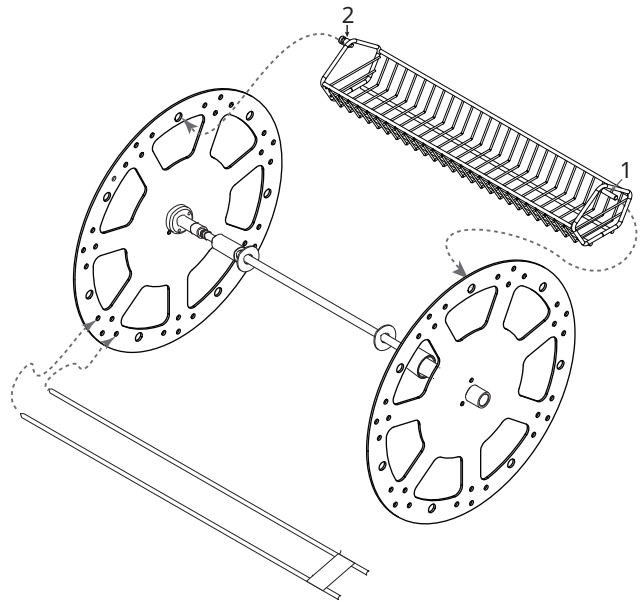

OPERATING INSTRUCTIONS

PRODUCT LOADING

STANDARD SPIT

Insert whole chickens with the legs toward the square end of the spit. Load up to 3, 3-1/2 lb (1,6 kg) chickens per spit for a total of 21 chickens or 4, 2-1/2 lb (1,1 kg) chickens for a total of 28 whole chickens.

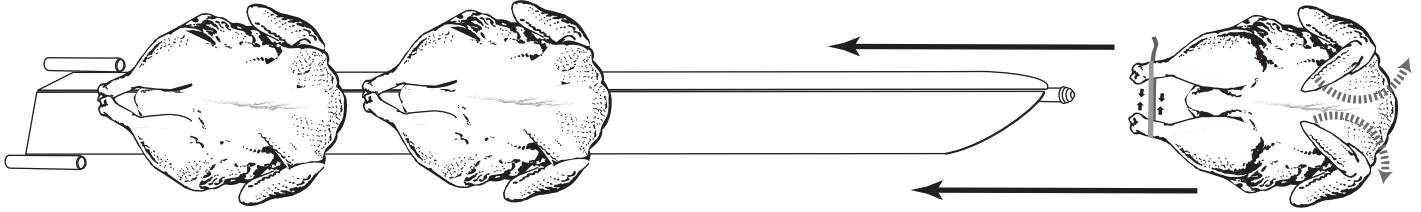

PIERCING SPIT (OPTION)

The optional piercing spit (item [SI-25729](#)) will accommodate 4, 2-1/2 lb (1,1 kg) to 3-1/2 lb (1,6 kg) whole chickens per spit.

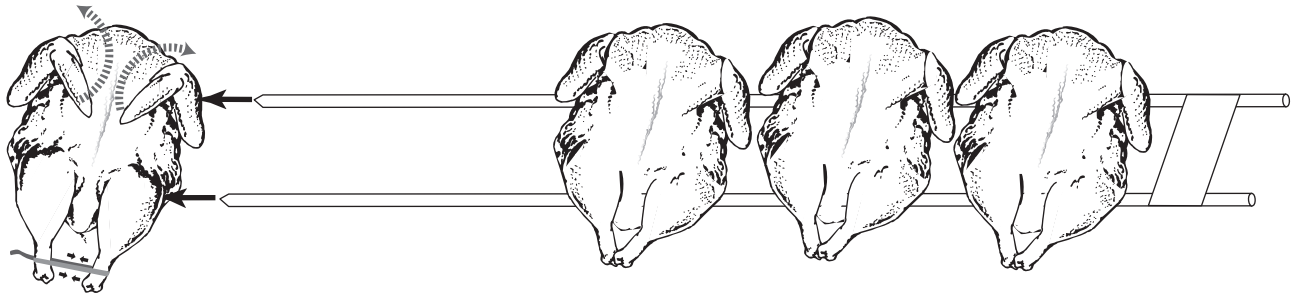

BASKET SPIT (OPTION)

Basket spits (item [BS-26019](#) with .50 diameter pin) are useful for irregular size products, denser items, or heavier products that need more support than the piercing spits.

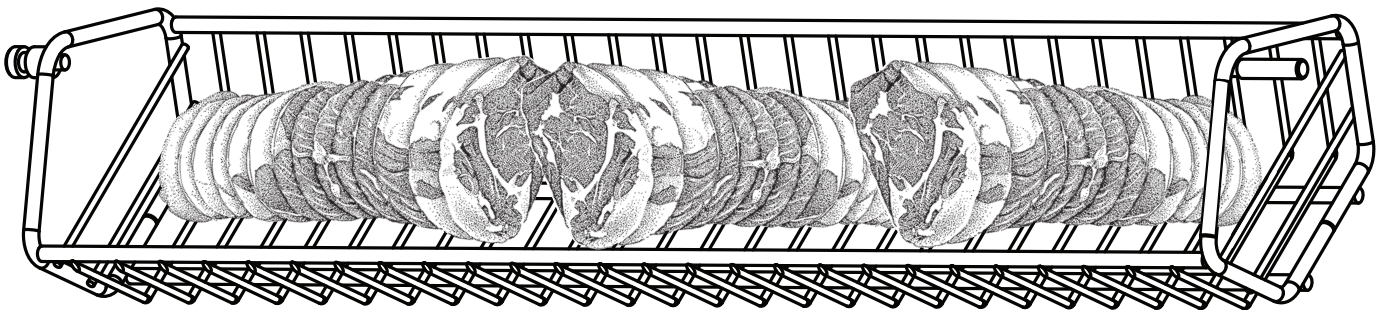

TURKEY SPIT (OPTION)

Insert whole turkey with legs towards the stop plate of the spit (item [5011681](#)) and slide in stopping tab to keep turkey in position. Load up to 1, 25 lb (11,4 kg) turkey per spit. Use up to three turkey spits per cavity for a total of 3 whole turkeys.

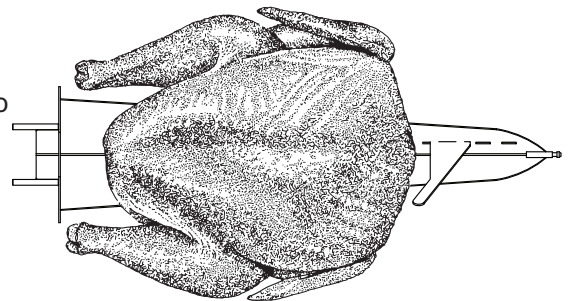

OPERATING INSTRUCTIONS

GREASE COLLECTION PROCEDURES

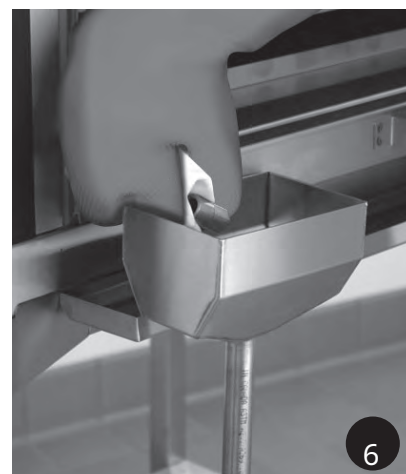

1. Open oven door and pull bottom grease tray forward by pulling on the handle. Pull tray forward only until it engages with the automatic stop mechanism. DO NOT pull tray out farther than mechanism will allow.
2. Position rolling grease collection unit in front of oven by pulling it forward. Turn and loosen black release knob to extend the telescoping funnel upward. Ensure top funnel cup is directly under the grease tray spout.
3. Position telescoping funnel behind elbow drain. Tighten black release knob to lock into place.
4. Wearing heat resistant gloves, turn the grease tray spout until the open end is pointing into the drain cup. Open end of spout should be pointing downwards at the 6:00 position. *Use caution as hot grease will begin draining from the grease tray spout into the grease collection cup.
5. Allow liquid and grease from oven grease tray to drain completely into the grease collection cup. Must allow grease to completely stop flowing and dripping.
6. Wearing heat resistant gloves, turn the grease tray spout until the open end is pointing up and no more grease can drain from it. Open end of the spout should be pointing upwards to the 12:00 position.

OPERATING INSTRUCTIONS

GREASE COLLECTION PROCEDURES



7. Turn and loosen black release knob and gently guide the telescoping funnel downward.
8. Telescoping funnel should be lowered to the level at which it stops without applying force. When properly lowered the funnel will fit under the oven unit.
9. Push grease tray back into oven and close oven door. Wipe any drippings with a wet cloth from the front of the tray and oven.
10. Check grease level in the rolling grease collection unit after every drain cycle. Using handle at front of rolling grease collection unit, lift lid of unit to observe grease level. If grease level is half full or more, the unit must be emptied into the building grease collection tank or dumpster.
11. Return the rolling grease collection unit to its original position by rolling it completely under the electric rotisserie oven.

CARE AND CLEANING

Protecting Stainless Steel Surfaces



It is important to guard against corrosion in the care of stainless steel surfaces. Harsh, corrosive, or inappropriate chemicals can completely destroy the protective surface layer of stainless steel. Abrasive pads, steel wool, or metal implements will abrade

surfaces causing damage to this protective coating and will eventually result in areas of corrosion. Even water, particularly hard water that contains high to moderate concentrations of chloride, will cause oxidation and pitting that result in rust and corrosion. In addition, many acidic foods spilled and left to remain on metal surfaces are contributing factors that will corrode surfaces.

Proper cleaning agents, materials, and methods are vital to maintaining the appearance and life of this appliance. Spilled foods should be removed and the area wiped as soon as possible but at the very least, a minimum of once per day. Always thoroughly rinse surfaces after using a cleaning agent and wipe standing water as quickly as possible after rinsing.

Cleaning Agents

Use non-abrasive cleaning products designed for use on stainless steel surfaces. Cleaning agents must be chloride-free compounds and must not contain quaternary salts. Never use hydrochloric acid (muriatic acid) on stainless steel surfaces. Failure to observe this precaution will void the warranty. Always use the proper cleaning agent at the manufacturer's recommended strength. Contact your local cleaning supplier for product recommendations.

Cleaning Materials

Cleaning can usually be accomplished with the proper cleaning agent and a soft, clean cloth. When more aggressive methods are needed, use a non-abrasive scouring pad on difficult areas and make certain to scrub with the visible grain of surface metal to avoid surface scratches. Never use wire brushes, metal scouring pads, or scrapers to remove food residue. Failure to observe this precaution will void the warranty.

NOTICE



To protect stainless steel surfaces, completely avoid the use of abrasive cleaning compounds, chloride based cleaners, or cleaners containing quaternary salts. **Never** use hydrochloric acid (muriatic acid) on stainless steel. **Never** use wire brushes, metal scouring pads or scrapers.

! WARNING



To prevent **serious personal injury, death, or property damage:**

The appliance must be cleaned thoroughly to avoid deposits of grease and or food residue inside the appliance that may catch fire. If fat deposits and/or food waste inside the appliance ignite, shut down the appliance immediately and keep the appliance door closed to extinguish the fire. If further extinguishing is required, disconnect the appliance from the main power and use a fire extinguisher (do not use water to extinguish a grease fire!). Failure to clean the appliance properly invalidates the warranty and relieves Alto-Shaam of all liability.

CARE AND CLEANING

ROTISSERIE CLEANING & MAINTENANCE

WARNING

Electric shock hazard.

Perform lockout/tagout procedures before cleaning or servicing this appliance.



CLEAN ROTISSERIE DAILY

1. Press the electrical power switch to the "off" position.
2. Allow rotisserie surfaces to cool.
3. Disconnect the rotisserie from the electrical power source.
4. Remove all detachable items such as spits, grease deflection trays, and grease collection unit. Drain grease from the drip pan and remove the drip pan from the oven when draining is complete.
5. Remove rotisserie drive assembly from the interior of the oven.
 - a. Supporting the central drive tube assembly, slide the metal washer and the collar on both sides of the drive tube toward the center of the tube to disengage.
 - b. Remove the disk drive wheels by pulling each directly toward the center of the oven compartment.
6. Wash all detached items separately in a ware washing area or sink. Do not use abrasive or corrosive cleaners.
7. Wipe the interior metal surfaces of the oven with a paper towel to remove loose food debris.
8. Clean interior with a damp cloth or sponge and any good commercial detergent at the recommended strength.
9. Spray heavily soiled areas with a water soluble degreaser and let stand for 10 minutes. After 10 minutes, remove soil with a plastic scouring pad.
10. Rinse surfaces thoroughly by wiping with sponge and clean, warm water.

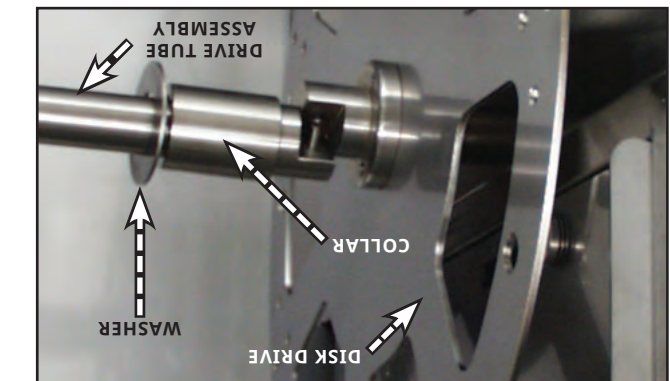

11. Remove excess water with sponge and wipe dry with a clean cloth or air dry. Leave door open until interior is completely dry. Always replace all removable parts including drip pan before operating.
12. Interior can be wiped with a sanitizing solution after cleaning and rinsing. This solution must be approved for use on stainless steel food contact surfaces.
13. Wipe control panel and door handle(s) thoroughly since these areas harbor food debris and bacteria.
14. Dry the control panel dry with a clean, soft cloth. To help maintain the protective film coating on polished stainless steel, clean the exterior of the cabinet with a cleaner recommended for stainless steel surfaces. Spray the cleaning agent on a clean cloth and wipe with the grain of the stainless steel. For optional color coated exterior surfaces, wipe with a damp cloth or sponge and wipe dry with a clean cloth.
15. Clean glass doors with a standard, commercial glass cleaner.

CAUTION

Always follow appropriate state or local health (hygiene) regulations regarding all applicable cleaning and sanitation requirements for equipment.



CAUTION

To prevent personal injury or property damage:

Always use hand protection when operating this appliance to avoid burns. Metal parts of this equipment become extremely hot when in operation.



CARE AND CLEANING

DAILY ROTISSERIE GASKET CLEANING

It is important to prolong the life of the oven gasket by cleaning this item on a daily basis. The acids and related compounds found in fat, particularly chicken fat, will weaken the composition of the gasket unless cleaned on a daily basis.

Routine cleaning will help protect the composition of the gasket from deterioration caused by acidic foods. After allowing the oven to cool, remove pull-out gasket and wash in hot, soapy water. **Do not** place gasket in the dishwasher.

	<p>CAUTION</p> <p>ALWAYS REPLACE THE DOOR GASKET BEFORE CLEANING THE INTERIOR OR OPERATING THE APPLIANCE.</p>
---	--

CLEAN ROTISSERIE CONVECTION BOX

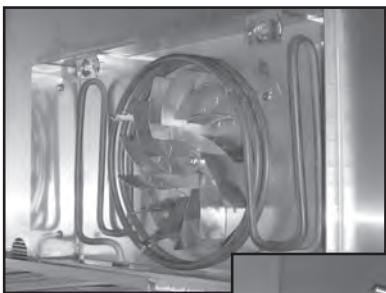

Remove the screws holding the convection fan panel unto the inside of the cooking chamber. Using a commercial degreaser spray the back and front and allow the degreaser to soften the grease for 10 minutes. Using a plastic scouring pad, scrub any hard deposits and rinse with hot water. Using a damp sponge and a plastic scouring pad if needed, wipe out any grease deposits that may be built up on the area surrounding the convection element and fan blade, taking care not to bend the element or the blade. A degreaser may be sprayed in this area to help dissolve any grease deposits that may be built up, but only a damp cloth or sponge can be used to remove the dissolved grease. Reinstall fan panel and tighten screws finger tight. UNIT MAY BE RUN AFTER CLEANING FOR 30-40 MINUTES TO AID IN DRYING, ALTHOUGH THERE MAY BE SOME SMOKING, WHICH IS NORMAL.



CHECK OVERALL CONDITION OF THE ROTISSERIE ONCE A MONTH

Check for physical damage and loose screws. Correct any problems before they begin to interfere with the operation of the oven.

	<p>WARNING</p> <p>To prevent serious personal injury, death, or property damage:</p> <p>Do not steam clean, hose down or flood the interior or exterior with water or liquid solution of any kind. Do not use water jet to clean. Failure to observe this precaution will void the warranty.</p>
---	---

		
<p>No scrapers</p>	<p>No wire brushes</p>	<p>No steel pads</p>

To protect stainless steel surfaces, completely avoid the use of abrasive cleaning compounds, chloride based cleaners, or cleaners containing quaternary salts. **Never** use hydrochloric acid (muriatic acid) on stainless steel. **Never** use wire brushes, metal scouring pads or scrapers.

TROUBLESHOOTING GUIDE

Code	Description	Possible Causes
E-10	Cavity air sensor shorted	Cavity air sensor reading < 5°F (-15°C). Verify sensor integrity.
E-11	Cavity air sensor open	Cavity air sensor reading > 517°F (269°C). Verify sensor integrity.
E-20	Product probe is shorted <i>Oven will cook in time only</i>	Product probe reading < 5°F (-15°C). Verify sensor integrity.
E-21	Product probe is open <i>Oven will cook in time only</i>	Product Probe reading > 517°F (269°C). Verify sensor integrity.
E-30	Under temperature	Unit has been more than 25°F (14°C) below set point for longer than 90 minutes.
E-31	Over temperature	Unit has been more than 60°F (33°C) above the maximum set-point for longer than 3 minutes. Holding Cabinets with this error code are more than 145°F (81°C) above the maximum set-point.
E-32	Safety switch open (Aux hi-limit switch)	Contact factory.
E-38	Internal software error	Contact factory.
E-39	Sensor error	Contact factory.
E-50	Temp. measurement error	Contact factory.
E-51	Temp. measurement error	Contact factory.
E-60	Real time clock error	Data set to factory default. Ensure that date and time are correct if applicable.
E-61	Real time clock error	Contact factory.
E-64	Clock is not oscillating	Contact factory.
E-70	Configuration connector error (DIP switch)	Refer to the electrical schematic and ensure dip switches on the control match the settings called out on the schematic. If the dip switch settings are correct, according to the schematic, replace the control.
E-78	Voltage low	Voltage below 90 VAC on a 125 VAC unit, or below 190 VAC on a 208-240 VAC unit. Adjust DC voltage. See "How to Adjust DC Voltage" in this manual.
E-79	Voltage high	Voltage over 135 VAC on a 125 VAC unit, or over 250 VAC on a 208-240 VAC unit. Adjust DC voltage. See "How to Adjust DC Voltage" in this manual.
E-80	EEPROM Error	Ensure that all temperatures and times are properly set. Contact factory if problem persists.
E-81	EEPROM Error	Contact factory.
E-82	EEPROM Error	Contact factory.
E-83	EEPROM Error	Contact factory.
E-85	EEPROM Error	All timers, if previously on, are now off. Possible bad EEPROM.
E-86	EEPROM Error	Stored HACCP memory corrupted. HACCP Address reset to 1. Possible bad EEPROM. Contact factory if problem persists.
E-87	EEPROM Error	Stored offsets corrupted. Offsets reset to 0. Control may need a recalibration. Possible bad EEPROM. Contact factory if problem persists.
E-88	EEPROM Error	All timer set-points are reset to 1 minute. Timers, if previously on, are now off. Possible bad EEPROM.
E-90	Button stuck	A button has been held down for > 60 seconds. Adjust control. Error will reset when the problem has been resolved.
E-91	Input failure	Contact factory.
E-dS	Datakey error	Datakey digital signature incompatible. Cycle power, and install compatible Datakey if error persists.
E-dT	Datakey error	Datakey incompatible with control. Install compatible Datakey.
E-dU	Datakey unplugged	Install Datakey and cycle power to control to clear error.
dLto	Datalogger has timed out	Cycle power. Contact factory if error persists.
dLSD	Micro SD card not plugged in	Plug in SD card and cycle power. Contact factory if error persists.
NOTE: If in doubt, always cycle the power to the control and contact factory if the problem persists.		

⚠ DANGER

To prevent serious injury, death, or property damage, **always** lock-out or post breaker panel until service work has been completed.



This section is provided for the assistance of qualified and trained service technicians only and is not intended for use by untrained or unauthorized service personnel. Failure to observe this precaution may void the warranty.



BULB REPLACEMENT INSTRUCTIONS

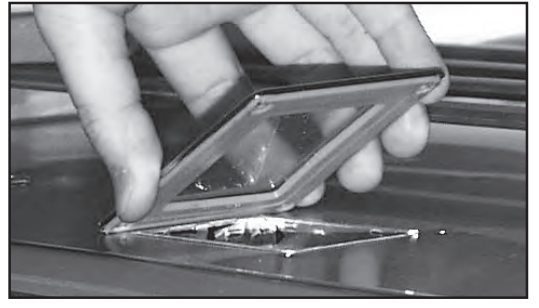
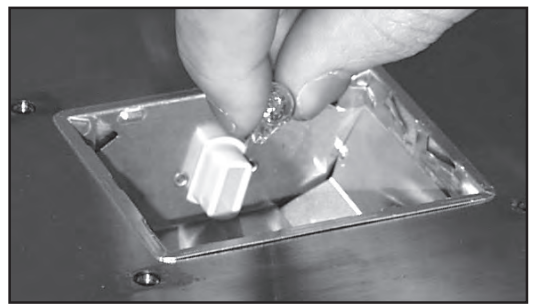
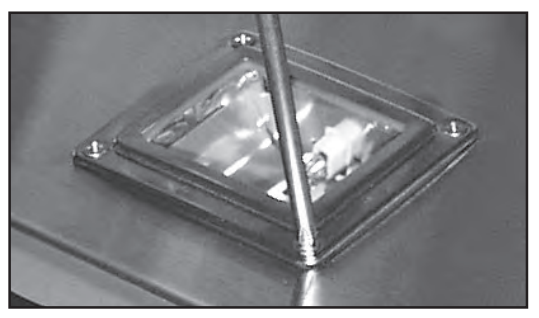

- To Replace Bulbs:**
- A. Remove four screws holding glass light cover (CV-26607) and gasket (GS-26609) in place, taking care to not let the glass cover (GL-26608) fall into the oven.
 - B. Pull bulb out.
 - C. Push replacement bulb (LP-34213) in place.
 - D. Re-install glass cover and gasket, securing with four screws removed in step one.

CAUTION

Do not handle new bulbs with bare hands. White cotton gloves should be worn when replacing bulbs.



CAUTION

The performance of this unit has been optimized using the factory provided bulbs. These bulbs should be replaced with an exact replacement or with a factory recommended replacement. These bulbs have been treated to resist breakage and must be replaced with similarly treated bulbs in order to maintain compliance with NSF standards. Do not over-tighten bulbs in their receptacles as this may cause damage to the bulb filament.



WARNING

To prevent SERIOUS INJURY, DEATH or PROPERTY DAMAGE:
All electrical connections must be made by a qualified and trained service technician in accordance with applicable electrical codes.



⚠ WARNING

Electric shock hazard.
Perform lockout/tagout procedures before cleaning or servicing this appliance.



FINAL FLOOR (RIGHT HAND SHOWN)

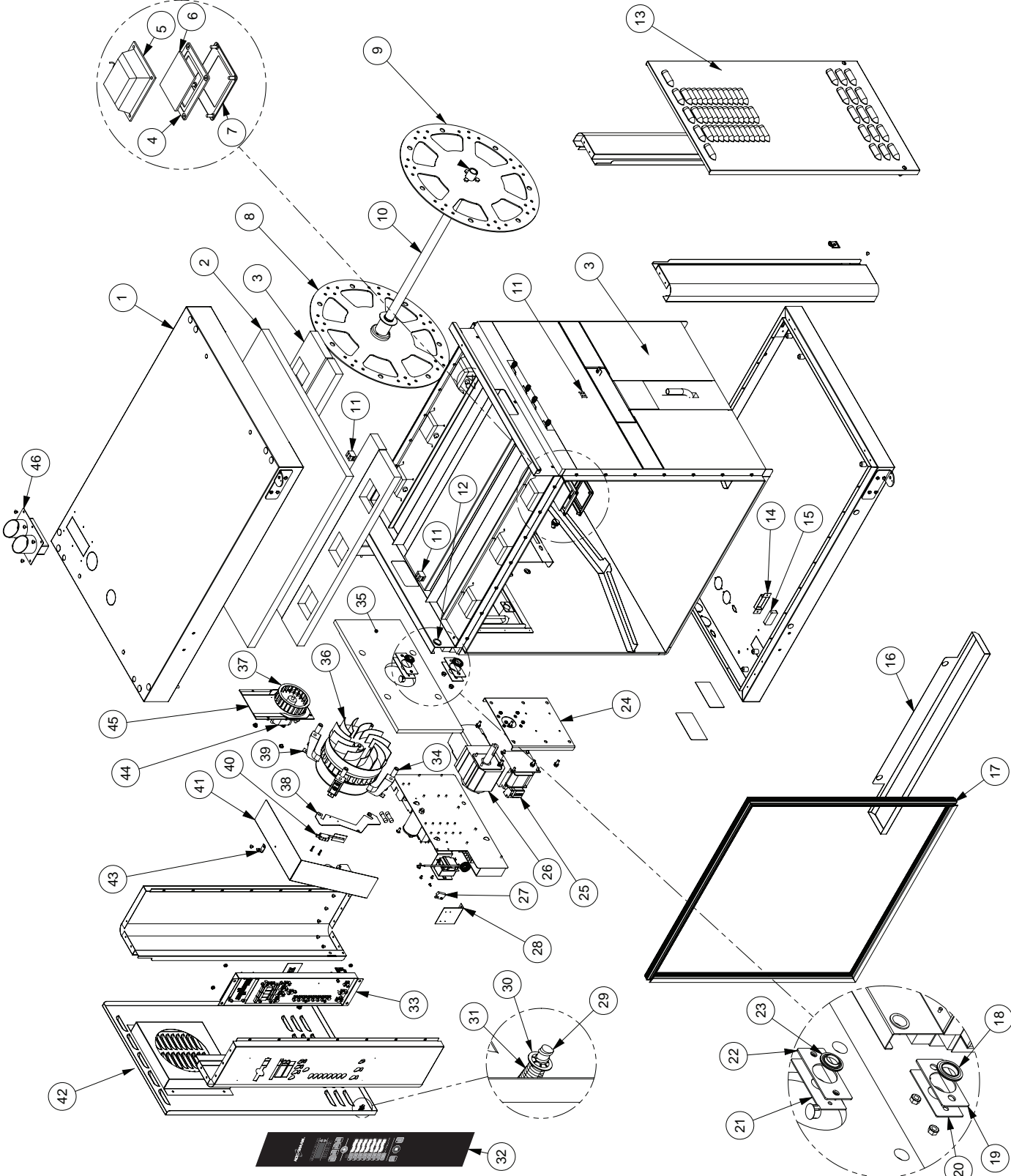

Part numbers and drawings are subject to change without notice.

SERVICE

FINAL FLOOR PARTS LIST

*NOT SHOWN MODEL > CURVED DOOR FLAT DOOR

ITEM	DESCRIPTION	PART NO.	QTY	PART NO.	QTY
1	SPOT ASSEMBLY, TOP PANEL	5009718	1		1
2	INSULATION, 1" x 4' x 25' #6, RT2300 (4.5 FT ²)	IN-24588	1	IN-24588	1
3	INSULATION, NON-CONTROL SIDE	IN-28356	1	IN-28356	1
4	GASKET, OVEN LIGHT	GS-26609	6	GS-26609	6
5	LAMP ASSEMBLY, 20W	LP-34185	6	LP-34185	6
	REPLACEMENT BULBS	LP-34213	6	LP-34213	6
6	GLASS, OVEN LIGHT	GL-26608	6	GL-26608	6
7	COVER FOR OVEN LIGHT	CV-26607	6	CV-26607	6
8	DISC ASSEMBLY, CONTROL SIDE WITH PIN	5016037	1	5016037	1
9	DISC ASSEMBLY, NON-CONTROL SIDE	5016038	1	5016038	1
10	DRIVE, TUBE WELD, ASSEMBLY	DV-26863	1	DV-26863	1
	BLOCK, 2 TERMINAL, PORCELAIN	BK-33546	4	BK-33546	4
12	7/8" SNAP BUSHING, BLACK	BU-3007	4	BU-3007	4
13	PANEL, NON-CONTROL SIDE	1001585	1	1001585	1
	BURGRUNDY	1007425	1	1007425	1
14	COVER, MAGNET, INSIDE, SINGLE	1001667	4	1001667	4
15	MAGNET, SMC0, SILVER	MA-27568	4	MA-27568	4
16	DRIP TRAY, FRONT	1009063	1	1009063	1
17	GASKET, DOOR	GS-25753	1	GS-25753	1
18	BUSHING, SEAL, ROTISSERIE SHAFT	BU-27387	1	BU-27387	1
19	SHIM, SEAL, ROTISSERIE MOTOR	1007676	1	1007676	1
20	PLATE, COVER, SEAL, ROTISSERIE MOTOR	1006744	1	1006744	1
21	PLATE, COVER, SEAL, FAN MOTOR	1006783	1	1006783	1
22	SHIM, SEAL, FAN MOTOR	1007675	1	1007675	1
23	BUSHING, SEAL, FAN SHAFT	BU-27388	1	BU-27388	1
24	PLATE, MOUNTING, MOTOR	1007015	1	1007015	1

CONTINUED ON NEXT PAGE



This section is provided for the assistance of qualified and trained service technicians only and is not intended for use by untrained or unauthorized service personnel. Failure to observe this precaution may void the warranty.

Part numbers and drawings are subject to change without notice.

SERVICE

FINAL FLOOR PARTS LIST (CONTINUED)

ITEM	DESCRIPTION	PART NO.	QTY	PART NO.	QTY	PART NO.	QTY
						FLAT DOOR	
						CURVED DOOR	
						MODEL <	
25	TRANSFORMER, STEP DOWN	TN-33460	1	TN-33460	1		1
26	MOTOR, AC, DRIVE, RIGHT ANGLE	MO-33893	1	MO-33893	1		1
	*MOTOR CAPACITOR	MO-33988	1	MO-33988	1		1
27	SWITCH, PROXIMITY SENSOR	SW-33906	1	SW-33906	1		1
28	BRACKET, DOOR SWITCH	1003474	1	1003474	1		1
29	STUD, CT M6 x 27mm, 1/4 TURN	ST-22193	1	ST-22193	1		1
30	WASHER, SAFETY, STEEL	WS-22195	4	WS-22195	4		4
31	SPRING, CT M6 x 48, SAFETY	SD-22194	1	SD-22194	1		1
32	PANEL, OVERLAY	PE-25738	1	PE-25738	1		1
		PE-25869	1	PE-25869	1		1
	INSERT CARD	PE-25740*	1	PE-25740*	1		1
		CC-34453	1	CC-34453	1		1
33	ASSEMBLY, CONTROLS, ELECTRIC	CC-34453	1	CC-34453	1		1
34	SPACER, MOTOR ASSEMBLY	SP-26950	4	SP-26950	4		4
35	INSULATION, CONNECTION BOX	IN-27845	1	IN-27845	1		1
36	CONNECTION MOTOR ASSEMBLY	5002607	1	5002607	1		1
37	EXHAUST VENT MOTOR FAN WHEEL	FA-33481	1	FA-33481	1		1
38	BRACKET, BLOWER, SAIL SWITCH	1001913	1	1001913	1		1
39	BRACKET, MOUNTING, AIR DUCT	1002069	3	1002069	3		3
40	SWITCH, FAN, SAIL	SW-33907	1	SW-33907	1		1
41	AIR DUCT	1002068	1	1002068	1		1
42	PANEL, CONTROL SIDE	5000949	1	5000949	1		1
		5006216	1	5006216	1		1
		CM-2023	1	CM-2023	1		1
43	CLAMP, HIGH LIMIT	CM-2023	1	CM-2023	1		1
44	FAN, MOTOR, EXHAUST + VENT, 240V, 50/60HZ	FA-33221	1	FA-33221	1		1
45	ASSEMBLY, SPOT, PLATE, HOUSING	5009414	1	5009414	1		1
46	WELD ASSEMBLY, FAUX DUAL EXHAUST	5009743	1	5009743	1		1



WARNING



Electric shock hazard.
Perform lockout/tagout procedures before
cleaning or servicing this appliance.

Part numbers and drawings are subject to change without notice.

SERVICE

FULL ASSEMBLY (CURVED DOOR, FLAT BACK SHOWN)

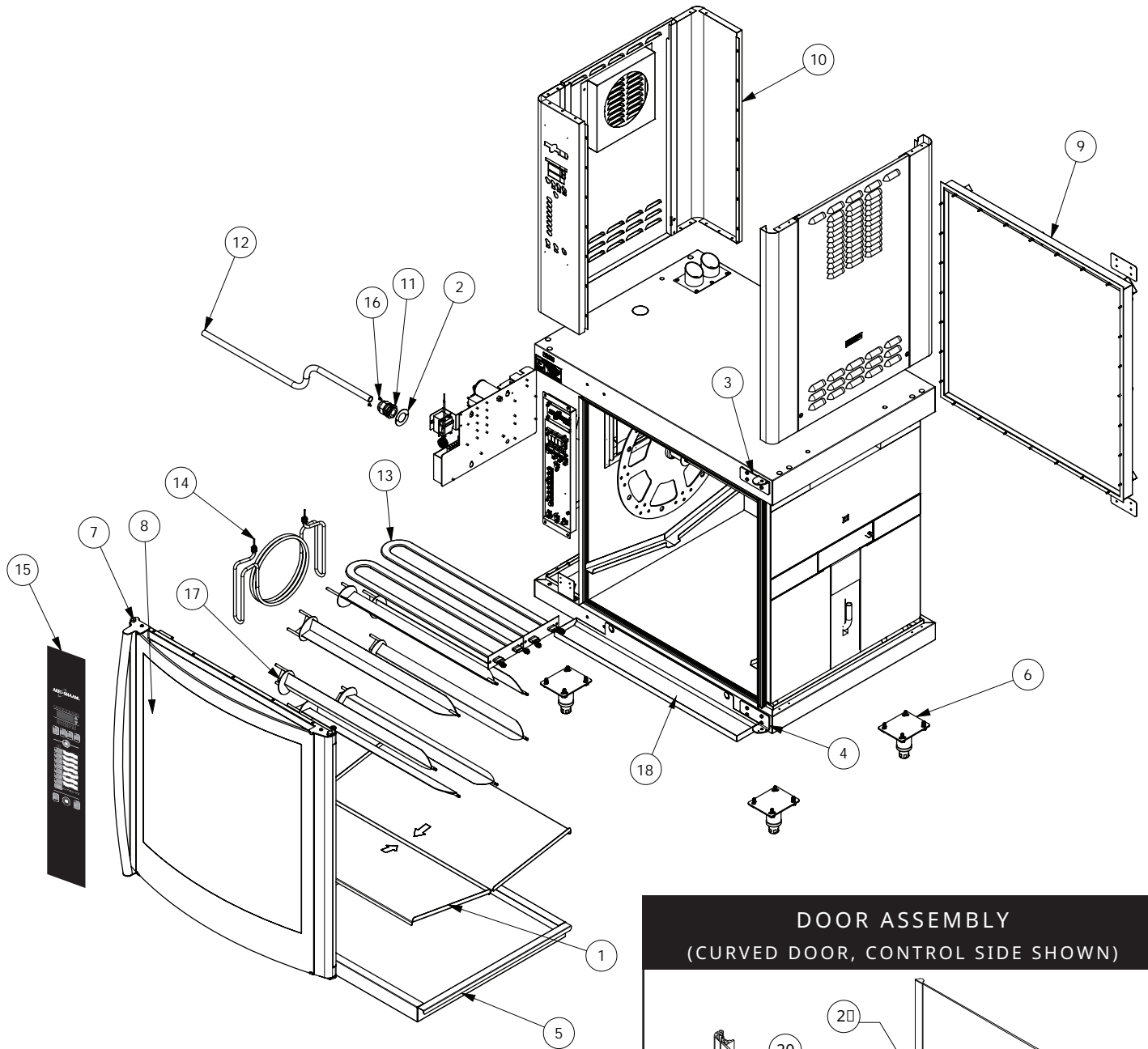

DOOR ASSEMBLY (CURVED DOOR, CONTROL SIDE SHOWN)

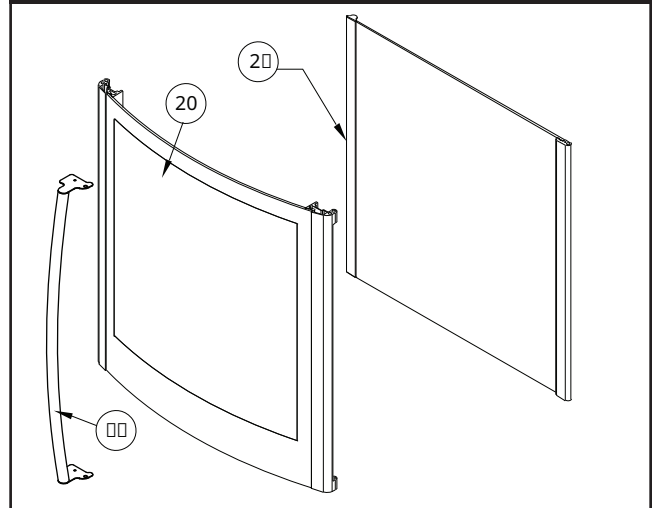

Part numbers and drawings are subject to change without notice.

FULL ASSEMBLY PARTS LIST

*NOT SHOWN		MODEL >	CURVED DOOR		FLAT DOOR	
ITEM	DESCRIPTION		PART NO.	QTY	PART NO.	QTY
1	PAN, DRIP		1001555	2	1001555	2
2	WASHER, STRAIN RELIEF		1002389	1	1002389	1
3	HINGE, UPPER, DOOR		1007672	1	1002596	1
4	HINGE, LOWER, DOOR		1007673	1	1002597	1
5	ASSEMBLY WELD, DRIP PAN		5001094	1	5001094	1
6	ASSEMBLY, LEG, 4" (102mm), ADJUSTABLE - SET OF 4 (INCLUDES BELOW ITEMS)		5001765	1	5001765	1
	LEG PLATE		LG-26123	4	LG-26123	4
	FEET, S/S, INSERT, ADJUSTABLE		FE-26125	4	FE-26125	4
	MOUNTING SCREWS		SC-2351	16	SC-2351	16
7	ASSEMBLY, DOOR, CONTROL SIDE		5005773	1	5009591	1
	ASSEMBLY, DOOR, NON-CONTROL SIDE		5006426	1	5009815	1
8	OUTER GLASS DOOR		5007824	1	—	—
9	OPTION, SOLID BACK		5006214	1	5006214	1
10	ASSEMBLY, PANELS	STAINLESS STEEL (RIGHT-HAND)	5006461	1	5006461	1
		(LEFT-HAND)	5007085	1	5007085	1
		BURGUNDY (RIGHT-HAND)	5006211	1	5006211	1
		(LEFT-HAND)	5007086	1	5007086	1
		BLACK (RIGHT-HAND)	5006212	1	5006212	1
		(LEFT-HAND)	5009209	1	5009209	1
11	BUSHING, STRAIN RELIEF, INT	208-240V, 1PH	BU-33505	1	BU-33505	1
		208-240V, 3PH; 380-415V	BU-33948	1	BU-33948	1
12	CORD; 6-1/2 FT (1,981 M)	208-240V, 1PH	CD-33841	1	CD-33841	1
		208-240V, 3PH	CD-3987	1	CD-3987	1
13	ELEMENT, RADIANT, FIREBAR	208V	EL-33974	2	EL-33974	2
		230V; 240V; 380-415V	EL-33973	2	EL-33973	2
14	ELEMENT, 5KW, CONVECTION	208V	EL-34106	1	EL-34106	1
		230V; 240V; 380-415V	EL-34107	1	EL-34107	1
15	PANEL, OVERLAY	DELUXE	PE-25738	1	PE-25738	1
		STANDARD	PE-25869	1	PE-25869	1
	INSERT CARD	DELUXE ONLY	PE-25740*	1	PE-25740*	1
16	RIVET, BLIND, #44, S/S		RI-2100	2	RI-2100	2
17	WELDMENT, SPIT, ANGLED		SI-25934	7	SI-25934	7
18	DRIP TRAY, FRONT		1009063	1	1009063	1

DOOR ASSEMBLY PARTS LIST

		MODEL >	CURVED DOOR		FLAT DOOR	
ITEM	DESCRIPTION		PART NO.	QTY	PART NO.	QTY
19	HANDLE, DOOR		HD-26900	1	HD-26900	1
20	DOOR, OUTER GLASS		5007824	1	—	—
21	DOOR, INNER GLASS	CONTROL SIDE	5006779	1	—	—
		NON-CONTROL SIDE	5008322	1	—	—

FASTENERS REQUIRED (NOT SHOWN)

DESCRIPTION	PART NO.	QTY	DESCRIPTION	PART NO.	QTY
WASHER, DOOR SPACE, BOTTOM	1002143	1	PIN, DOOR, BOTTOM	PI-26352	1
WASHER, FLAT, M8	WS-22298	1	NUT, HEX JAM 5/16-18	NU-25897	1
SCREW, 5/16-18 x 5/8	SC-2900	3	SCREW, INSERT	SC-25781	1
PIN, DOOR, TOP	PI-26350	1	SCREW, 8-32 x 3/8	SC-22378	6

Part numbers and drawings are subject to change without notice.

SERVICE

INTERIOR VIEW

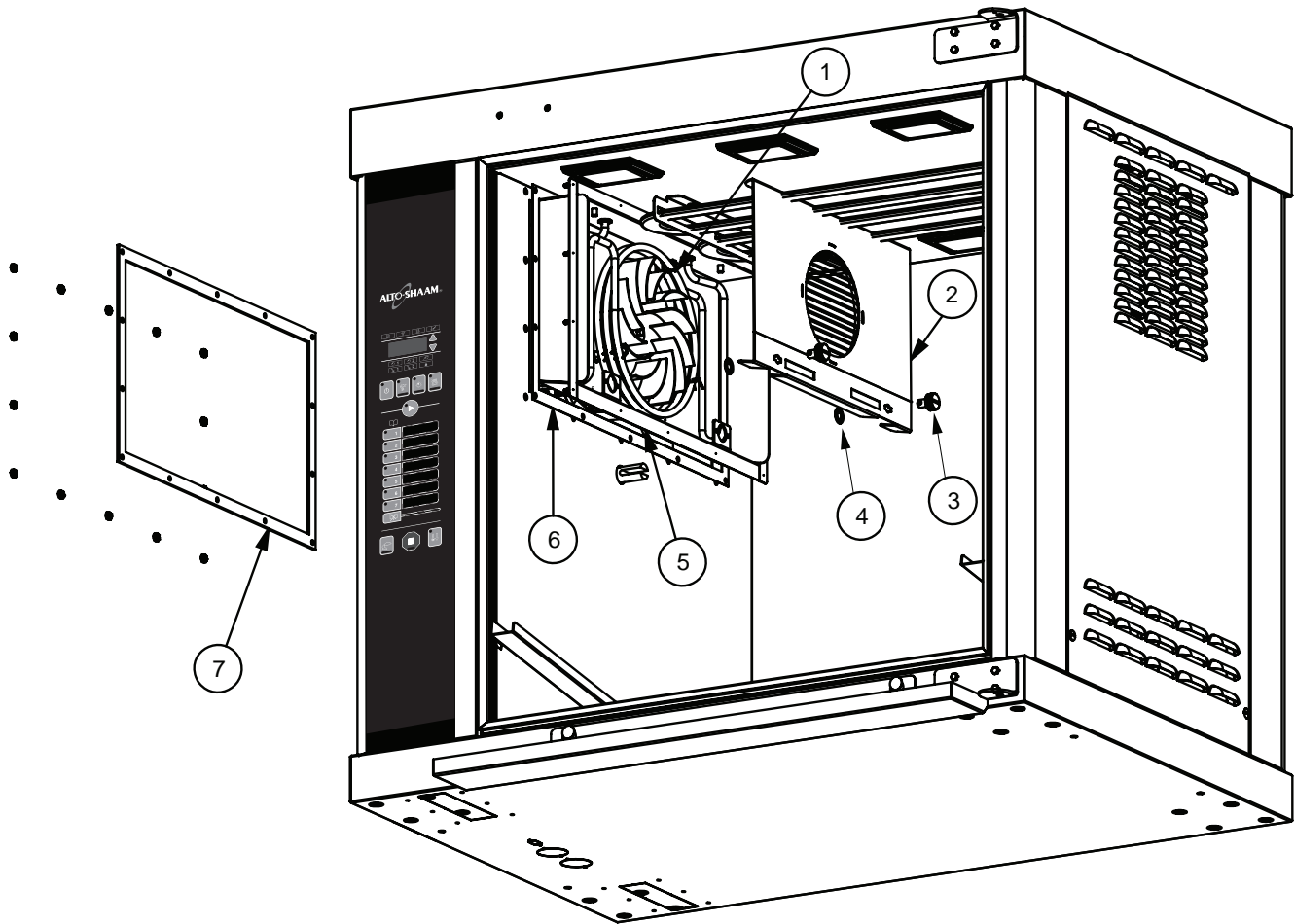

ITEM	DESCRIPTION	MODEL >		FLAT DOOR	
		CURVED DOOR		PART NO.	QTY
1	BRACKET, ELEMENT	1003595	1	1003595	1
2	WELDMENT, COVER, BLOWER	5005782	1	5005782	1
3	BLOWER COVER SCREW	CL-24089	2	CL-24089	2
4	BLOWER COVER SCREW LOCK WASHER	WS-24090	2	WS-24090	2
5	STUDWELD (SPOT) DUCT, BLOWER	5005848	1	5005848	1
6	GASKET, AIR BOX	GS-27389	1	GS-27389	1
7	PLATE, SUPPORT	1006650	1	1006650	1

Part numbers and drawings are subject to change without notice.

ELECTRICAL SERVICE VIEW

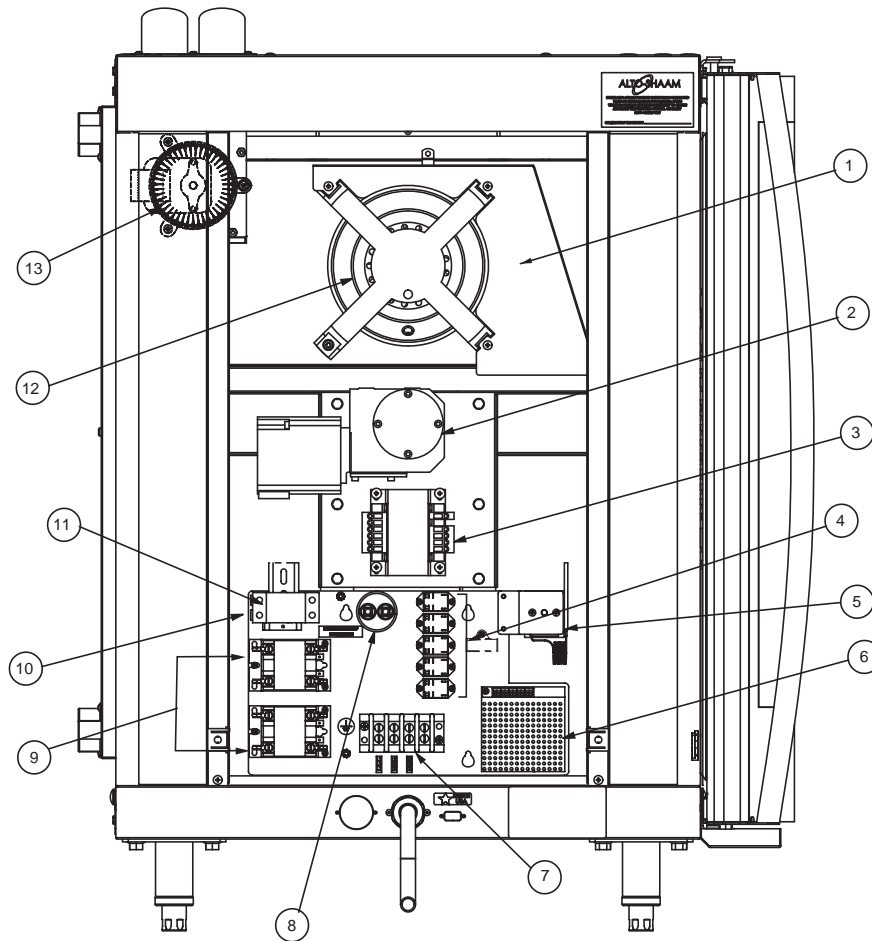

*NOT SHOWN		MODEL >	CURVED DOOR		FLAT DOOR	
ITEM	DESCRIPTION	PART NO.	QTY	PART NO.	QTY	
1	AIR DUCT	1002068	1	1002068	1	
2	MOTOR DRIVE, 230V, AC	MO-33893	1	MO-33893	1	
3	TRANSFORMER, STEP DOWN	TN-33460	1	TN-33460	1	
4	RELAY, POWER	RL-33930	5	RL-33930	5	
5	SWITCH, HIGH LIMIT	SW-34454	1	SW-34454	1	
6	BOARD, POWER SUPPLY, 12V DC, SWITCH	BA-36144	1	BA-36144	1	
7	TERMINAL BLOCK	BK-3023	1	BK-3023	1	
8	FAN, BLOWER MOTOR CAPACITOR, 4 UF	FA-33931	1	FA-33931	1	
9	CONTACTOR, 208/240V 3 POLE 25 AMP	CN-3052	2	CN-3052	2	
	RESISTOR, MOV, SURGE PROTECTOR	RS-3578*	2	RS-3578*	2	
10	FUSE, 15A, CLASS G	FU-34772	2	FU-34772	2	
11	FUSE HOLDER	FU-34771	1	FU-34771	1	
12	MOTOR, CONVECTION FAN, 220-240V	M0-33892	1	M0-33892	1	
13	EXHAUST VENT MOTOR FAN WHEEL, 240V, 50/60HZ	FA-33221	1	FA-33221	1	
14	SWITCH, FAN, SAIL	SW-33907*	1	SW-33907*	1	
15	DRIVE MOTOR CAPACITOR	MO-33988*	1	MO-33988*	1	

Part numbers and drawings are subject to change without notice.

SERVICE

REPLACEMENT OF GLASS DOOR (FLAT DOOR SHOWN)

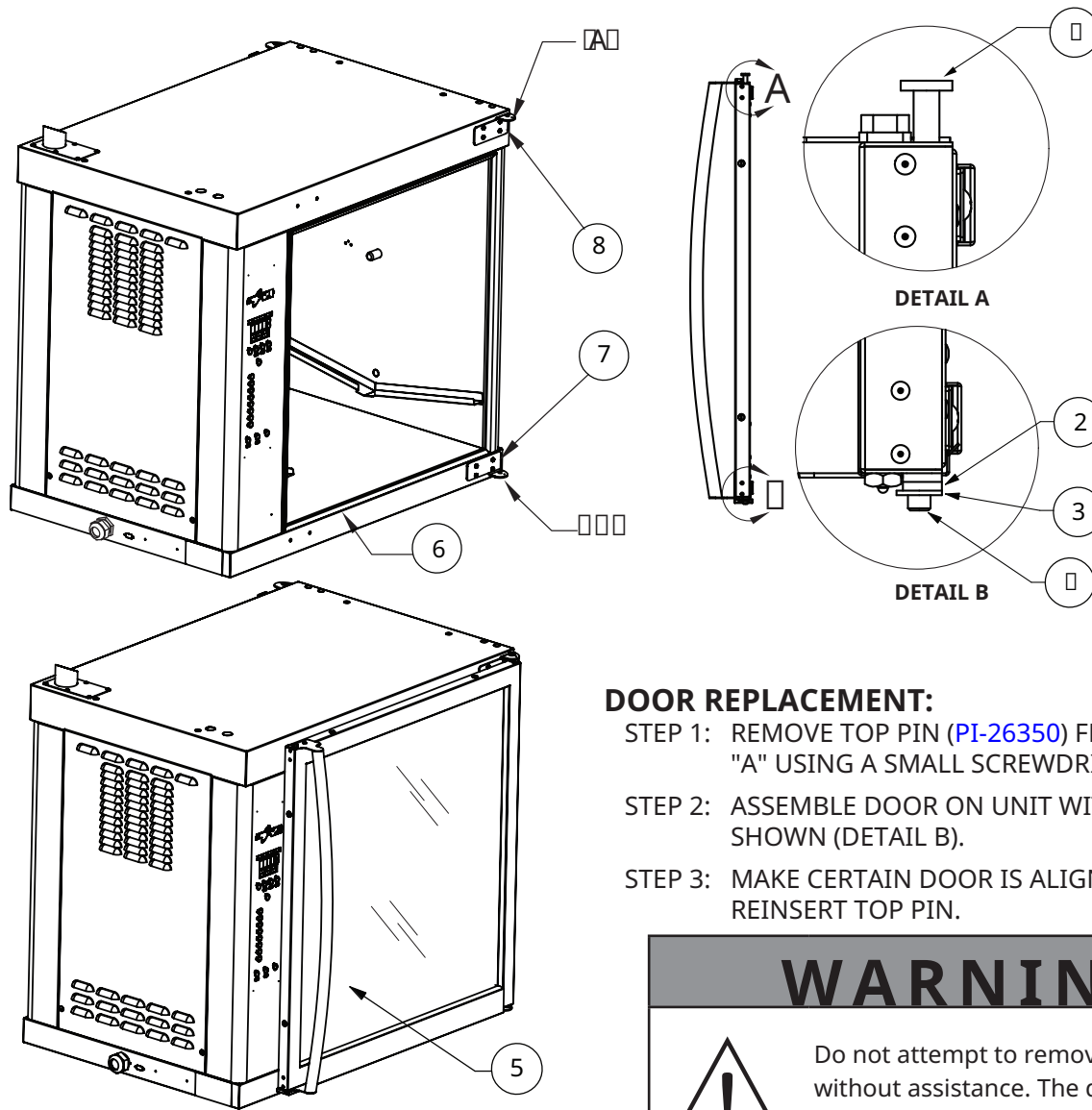

DOOR REPLACEMENT:

- STEP 1: REMOVE TOP PIN (PI-26350) FROM BRACKET "A" USING A SMALL SCREWDRIVER.
- STEP 2: ASSEMBLE DOOR ON UNIT WITH SPACERS AS SHOWN (DETAIL B).
- STEP 3: MAKE CERTAIN DOOR IS ALIGNED AND REINSERT TOP PIN.

WARNING



Do not attempt to remove the door without assistance. The door is extremely heavy, will be damaged if dropped and may cause serious injury.

NOT SHOWN		MODEL >	CURVED DOOR		FLAT DOOR	
ITEM	DESCRIPTION		PART NO.	QTY	PART NO.	QTY
1	PIN, DOOR, TOP		PI-26350	1	PI-26350	1
2	SPACER		1002143	1	1002143	1
3	WASHER		WS-22298	1	WS-22298	1
4	PIN, DOOR, BOTTOM		PI-26352	1	PI-26352	1
5	ASSEMBLY, DOOR, CONTROL SIDE		5006779	1	5009591	1
	ASSEMBLY, DOOR, NON-CONTROL SIDE		5007824	1	5009815	1
6	GASKET, DOOR		GS-25753	1	GS-25753	1
7	HINGE, LOWER, DOOR		1007673	1	1007673	1
8	HINGE, UPPER, DOOR		1007672	1	1007672	1

Part numbers and drawings are subject to change without notice.

STAINLESS STEEL BACK PANEL (5006214)

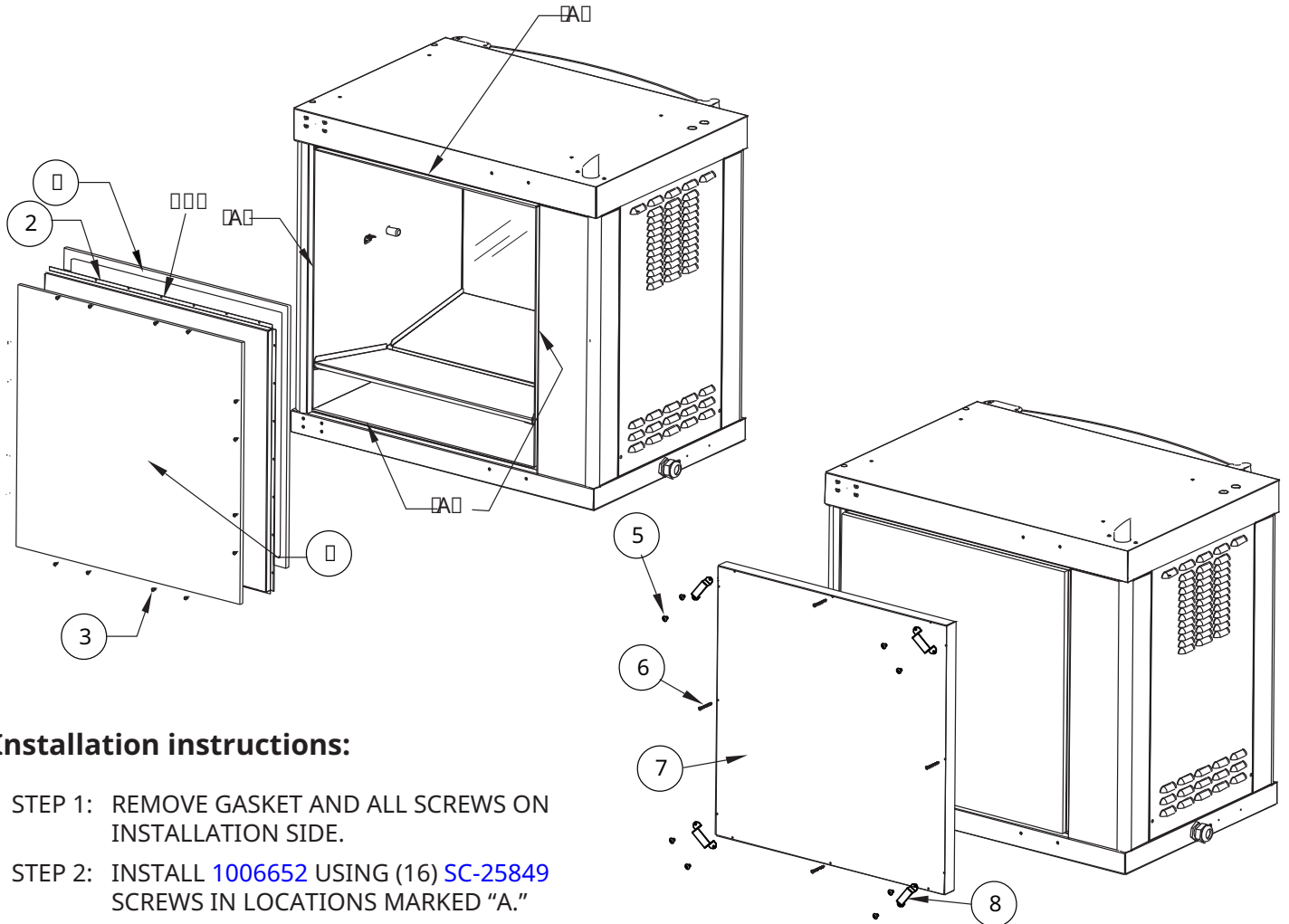

Installation instructions:

- STEP 1: REMOVE GASKET AND ALL SCREWS ON INSTALLATION SIDE.
- STEP 2: INSTALL [1006652](#) USING (16) [SC-25849](#) SCREWS IN LOCATIONS MARKED "A."
- STEP 3: INSTALL [1006746](#) INTO [1006652](#) USING (4) [SC-27843](#) SCREWS, (8) [SC-2459](#) SCREWS AND (4) [1002822](#) SPACERS.
- STEP 4: SEAL COMPLETE PERIMETER OF OPENING WITH SILICONE "B".

ITEM	DESCRIPTION	MODEL >		FLAT DOOR	
		CURVED DOOR	QTY	PART NO.	QTY
1	GASKET TAPE	GS-28123	1	GS-28123	1
2	PANEL, INTERIOR S/S BACK	1006652	1	1006652	1
3	SCREW, PAN HEAD	SC-25849	16	SC-25849	16
4	INSULATION, FIBERGLASS	IN-2003	1	IN-2003	1
5	SCREW, NC, PHILL TRUSS	SC-2459	8	SC-2459	8
6	SCREW, PAN HEAD, PHILLIPS	SC-27843	12	SC-27843	12
7	PANEL, EXTERIOR S/S BACK	1006746	1	1006746	1
8	SPACER, SOLID BACK	1002822	4	1002822	4

Part numbers and drawings are subject to change without notice.

SERVICE

GREASE COLLECTION UNIT (5012271)

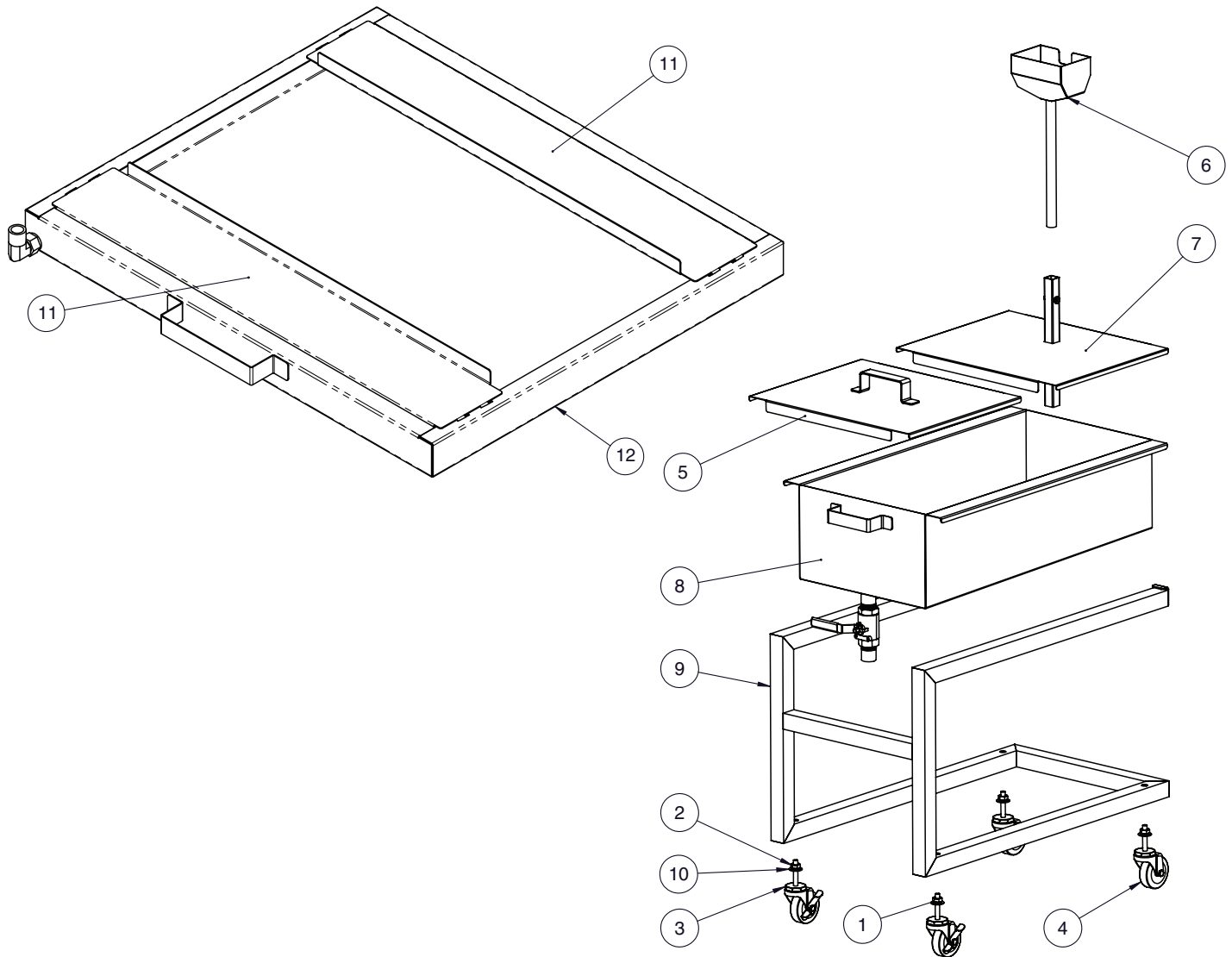

ITEM	DESCRIPTION	PART NO.	QTY
1	WASHER, LOCK, 1/2" DIA	WS-24893	4
2	NUT, 1/2-13 S/S JAMB	NU-24736	4
3	CASTER, STEM 3" SWIVEL, WITH BRAKE	CS-24857	2
4	CASTER, STEM 3" SWIVEL	CS-24858	2
5	COVER, SPACER	5012270	1
6	FUNNEL, TUBE	5012268	1
7	FUNNEL, COVER	5012266	1
8	GREASE PAN	5012265	1
9	FRAME WELDMENT	5012264	1
10	DIRECTIONAL PANEL SPACER	1006601	4
11	DRIP PAN COVER	1011621	2
12	ASSEMBLY WELD, DRIP PAN WITH DRAIN	5012290	1

Part numbers and drawings are subject to change without notice.

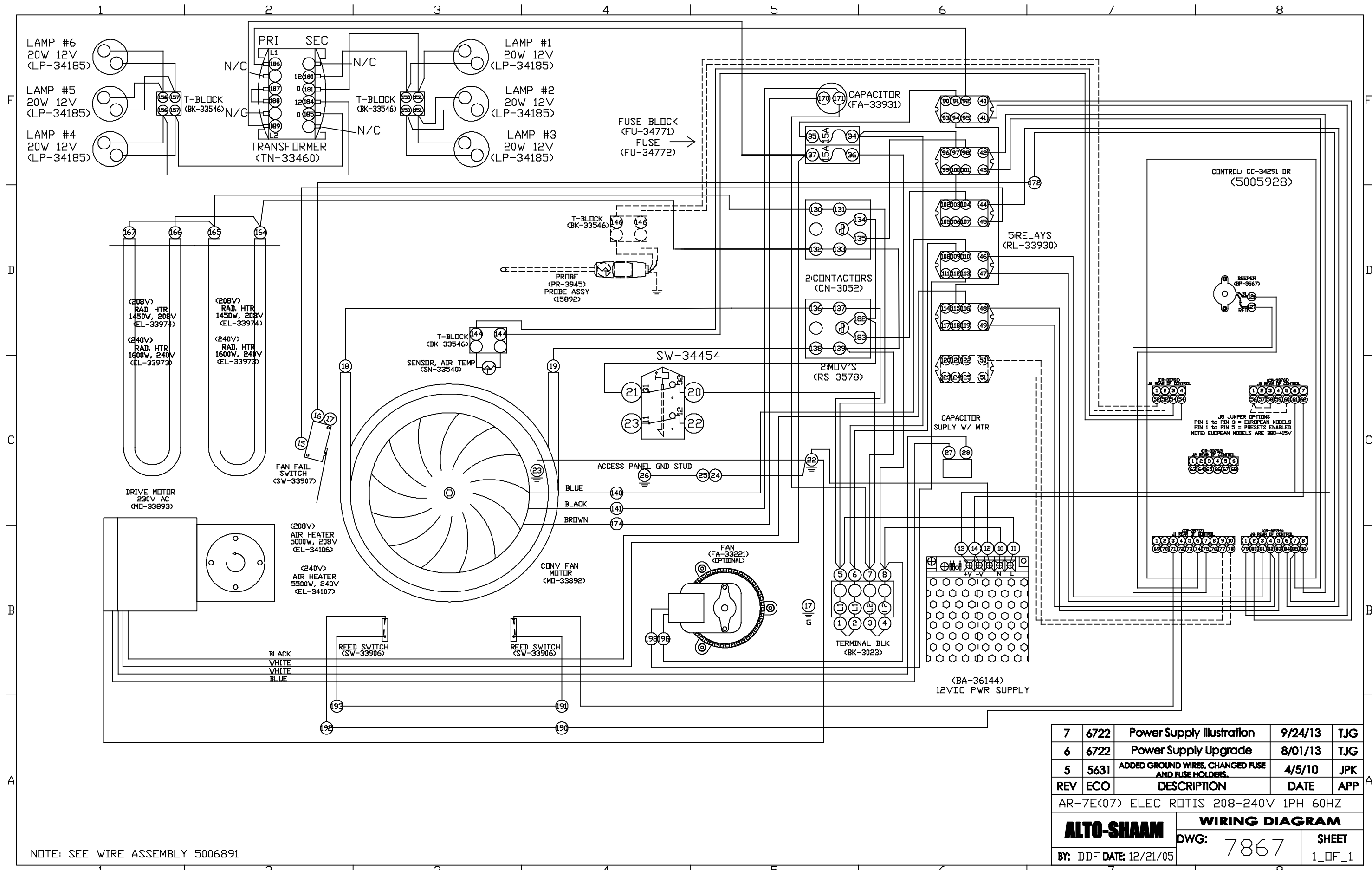

NOTE: SEE WIRE ASSEMBLY 5006891

7	6722	Power Supply Illustration	9/24/13	TJG
6	6722	Power Supply Upgrade	8/01/13	TJG
5	5631	ADDED GROUND WIRES, CHANGED FUSE AND FUSE HOLDERS.	4/5/10	JPK
REV	ECO	DESCRIPTION	DATE	APP
AR-7E(07) ELEC ROTIS 208-240V 1PH 60HZ				
ALTO-SHAAM		WIRING DIAGRAM		
BY: DDF	DATE: 12/21/05	DWG: 7867	SHEET 1_OF_1	

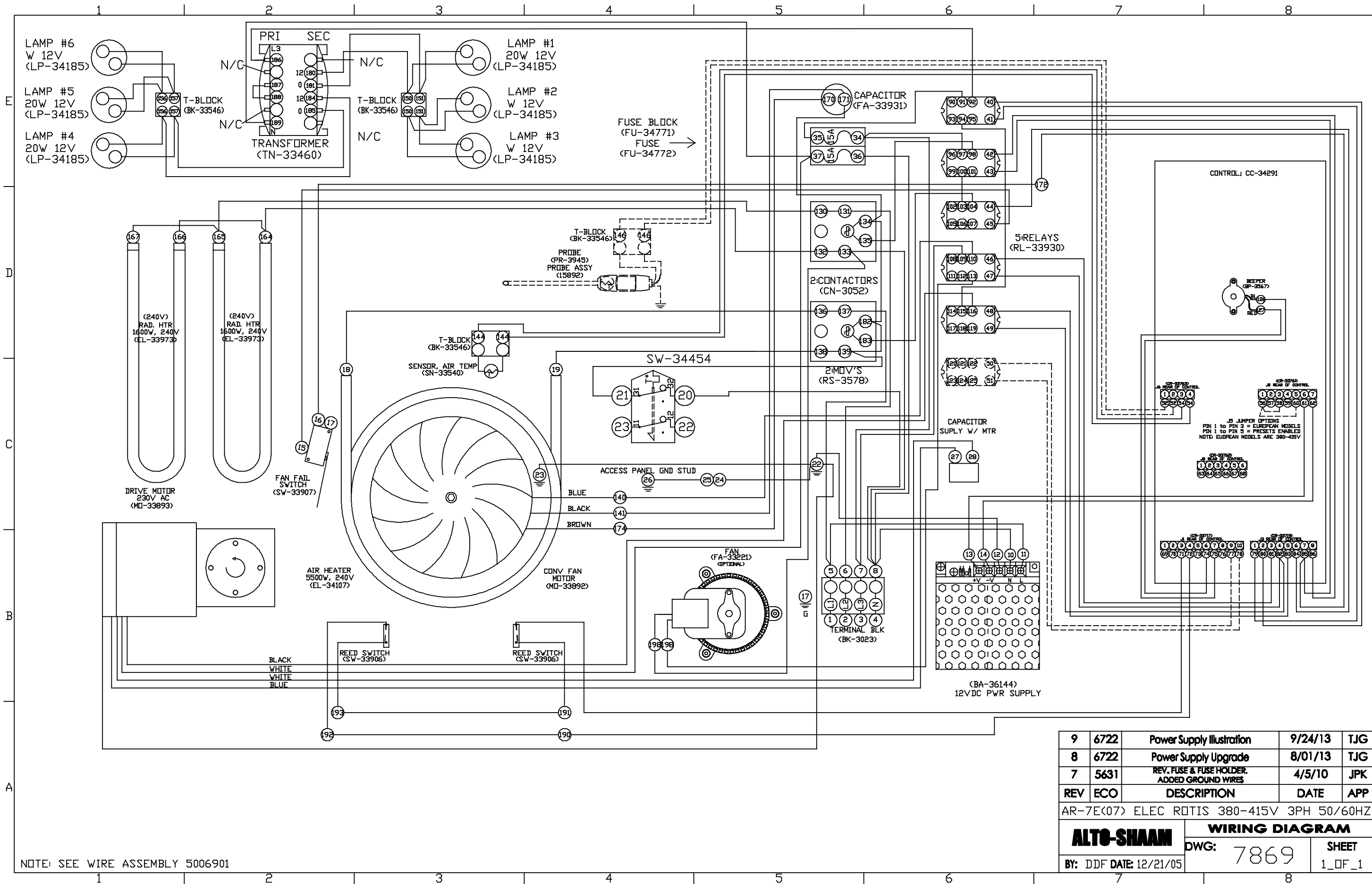

NOTE: SEE WIRE ASSEMBLY 5006901

9	6722	Power Supply Illustration	9/24/13	TJG
8	6722	Power Supply Upgrade	8/01/13	TJG
7	5631	REV. FUSE & FUSE HOLDER, ADDED GROUND WIRES	4/5/10	JKP
REV	ECO	DESCRIPTION	DATE	APP

AR-7E(07) ELEC ROTISSE 380-415V 3PH 50/60HZ

ALTO-SHAAM		WIRING DIAGRAM	
DWG:	7869	SHEET	1_OF_1
BY: DDF	DATE: 12/21/05		

Alto-Shaam, Inc. warrants to the original purchaser only that any original part that is found to be defective in material or workmanship will, at Alto-Shaam's option, subject to provisions hereinafter stated, be replaced with a new or rebuilt part.

The original parts warranty period is as follows:

For the refrigeration compressor on Alto-Shaam Quickchillers™, five (5) years from the date of installation of appliance.

For the heating element on Halo Heat® cooking and holding ovens, as long as the original purchaser owns the oven. This excludes holding only equipment.

For all other original parts, one (1) year from the date of installation of appliance or fifteen (15) months from the shipping date, whichever occurs first.

The labor warranty period is one (1) year from the date of installation or fifteen (15) months from the shipping date, whichever occurs first.

Alto-Shaam will bear normal labor charges performed during standard business hours, excluding overtime, holiday rates or any additional fees.

To be valid, a warranty claim must be asserted during the applicable warranty period. This warranty is not transferable.

This warranty does not apply to:

1. Calibration.
2. Replacement of light bulbs, door gaskets, and/or the replacement of glass due to damage of any kind.
3. Equipment damage caused by accident, shipping, improper installation or alteration.
4. Equipment used under conditions of abuse, misuse, carelessness or abnormal conditions, including but not limited to, equipment subjected to harsh or inappropriate chemicals, including but not limited to, compounds containing chloride or quaternary salts, poor water quality, or equipment with missing or altered serial numbers.
5. Damage incurred as a direct result of poor water quality, inadequate maintenance of steam generators and/or surfaces affected by water quality. Water quality and required maintenance of steam generating equipment is the responsibility of the owner/operator.
6. Damage caused by use of any cleaning agent other than Alto-Shaam's Combitherm® Cleaner, including but not limited to damage due to chlorine or other harmful chemicals. **Use of Alto-Shaam's Combitherm® Cleaner on Combitherm® ovens is highly recommended.**
7. Any losses or damage resulting from malfunction, including loss of product, food product, revenue, or consequential or incidental damages of any kind.
8. Equipment modified in any manner from original model, substitution of parts other than factory authorized parts, removal of any parts including legs, or addition of any parts.

This warranty is exclusive and is in lieu of all other warranties, express or implied, including the implied warranties of merchantability and fitness for a particular purpose. In no event shall Alto-Shaam be liable for loss of use, loss of revenue or profit, or loss of product, or for any indirect, special, incidental, or consequential damages. No person except an officer of Alto-Shaam, Inc. is authorized to modify this warranty or to incur on behalf of Alto-Shaam any other obligation or liability in connection with Alto-Shaam equipment.

Effective November 1, 2012

W164 N9221 Water Street • P.O. Box 450
Menomonee Falls, Wisconsin 53052-0450 U.S.A.

PHONE: 262.251.3800 • 800.558.8744 U.S.A. / CANADA
FAX: 262.251.7067 • 800.329.8744 U.S.A. ONLY
www.alto-shaam.com

Printed in the U.S.A