

**ALTO-SHAAM®**

**Rotisserie**  
**Gas**



**Models:**  
**AR-6G**



- **INSTALLATION**
- **OPERATION**
- **MAINTENANCE**

**HALO**  
**HEAT®**

**24•7**  
Your Service Hotline  
**1-800-558-8744**

W164 N9221 Water Street • P.O. Box 450 • Menomonee Falls, Wisconsin 53052-0450 USA  
PHONE: 262.251.3800 • 800.558.8744 USA/CANADA FAX: 262.251.7067 • 800.329.8744 U.S.A. ONLY  
[www.alto-shaam.com](http://www.alto-shaam.com)

# ALTO-SHAAM®

Delivery . . . . . 1  
 Unpacking . . . . . 1  
 Safety Procedures and Precautions . . . . . 2

**Installation**

Common Specifications . . . . . 3  
 Accessories . . . . . 3  
 Dimension Drawings . . . . . 4  
 Technical Components . . . . . 5  
 Installation Codes & Standards . . . . . 6  
 Ventilation Requirements . . . . . 6  
 Positioning on Site . . . . . 6  
 Positioning Requirements . . . . . 7  
 Ventilation Instructions . . . . . 8  
 Electrical . . . . . 9  
 Air Supply . . . . . 10  
 Air Adjustments . . . . . 10  
 Gas Connections . . . . . 11-13  
 Securing Electrical Access Cover . . . . . 13  
 Leak Testing . . . . . 14  
 Gas Exhaust . . . . . 14  
 Ignition System . . . . . 14

**Operating Instructions**

Burner Lighting Instructions . . . . . 15  
 Controls . . . . . 16  
 Door Catch . . . . . 16  
 Placement & Adjustment of Spits . . . . . 17  
 Product Preparation . . . . . 17  
 Skewer Preparation & Loading . . . . . 18  
 Cooking Time . . . . . 18

**Care and Cleaning**

Equipment Care . . . . . 19  
 Daily Cleaning . . . . . 19  
 Cleaning & Reasoning of Cast Iron Tiles . . . . . 20

**Maintenance**

Changing of Light Bulbs . . . . . 20  
 Opening Machine Compartments . . . . . 20

**Service**

Troubleshooting Guide . . . . . 21  
 Full Assembly View & Part List . . . . . 22  
 Final Floor Assembly View & Part List . . . . . 23-24  
 Motor Mount Assembly View & Part List . . . . . 25  
 Top Assembly View & Part List . . . . . 26  
 Gas Plumbing Assembly & Part List . . . . . 27  
 Bottom Assembly View & Part List . . . . . 28-29  
 Bulb Replacement . . . . . 30

**Installation Checklist**

Clearances . . . . . 31  
 Gas connections . . . . . 31  
 Physical Condition . . . . . 31

**Wire Diagrams**

Always refer to the wire diagram(s) included with the unit for most current version.

**Warranty**

Transportation Damage and Claims . Back Cover  
 Limited Warranty . . . . . Back Cover

<b>DANGER</b>	
	<p><b>IMPROPER INSTALLATION, ALTERATION, ADJUSTMENT, SERVICE, OR MAINTENANCE COULD RESULT IN SEVERE INJURY, DEATH, OR CAUSE PROPERTY DAMAGE.</b></p> <p><b>READ THE INSTALLATION, OPERATING AND MAINTENANCE INSTRUCTIONS THOROUGHLY BEFORE INSTALLING OR SERVICING THIS EQUIPMENT.</b></p>

 <b>DANGER</b>	
	<p><b>DO NOT store or use gasoline or other flammable vapors or liquids in the vicinity of this or any other appliance.</b></p>

# ALTO-SHAAM®

## DELIVERY

This Alto-Shaam appliance has been thoroughly tested and inspected to ensure only the highest quality unit is provided. Upon receipt, check for any possible shipping damage and report it at once to the delivering carrier. *See Transportation Damage and Claims section located in this manual.*

This appliance, complete with unattached items and accessories, may have been delivered in one or more packages. Check to ensure that all standard items and options have been received with each model as ordered.

Save all the information and instructions packed with the appliance. Complete and return the warranty card to the factory as soon as possible to ensure prompt service in the event of a warranty parts and labor claim.

This manual must be read and understood by all people using or installing the equipment model. Contact the Alto-Shaam Tech Team Service Department if you have any questions concerning installation, operation, or maintenance.

**NOTE:** All claims for warranty must include the full model number and serial number of the unit.

## UNPACKING

1. Carefully remove the appliance from the carton or crate.

**NOTE:** Do not discard the carton and other packaging material until you have inspected the unit for hidden damage and tested it for proper operation.

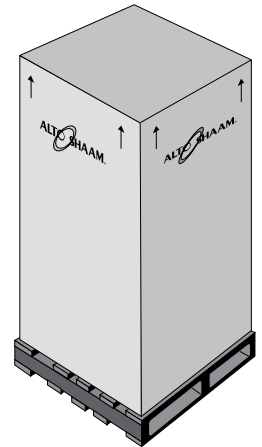

2. Read all instructions in this manual carefully before initiating the installation of this appliance.

**DO NOT DISCARD THIS MANUAL.**

This manual is considered to be part of the appliance and is to be provided to the owner or manager of the business or to the person responsible for training operators. *Additional manuals are available from the Alto-Shaam Tech Team Service Department.*

3. Remove all protective plastic film, packaging materials, and accessories from the appliance before connecting electrical power. Store any accessories in a convenient place for future use.

## CAUTION



**TO PREVENT PERSONAL INJURY,  
USE CAUTION WHEN MOVING OR  
LEVELING THIS APPLIANCE.**

**THE INFORMATION CONTAINED IN THIS MANUAL IS IMPORTANT FOR THE PROPER INSTALLATION OF THIS OVEN. PLEASE READ CAREFULLY AND RETAIN FOR FUTURE REFERENCE.**

**IMPROPER CONNECTION OF THIS APPLIANCE WILL NULLIFY ALL WARRANTIES.**

**LES INFORMATIONS CONTENUES DANS CE MANUEL SONT IMPORTANTES POUR L'INSTALLATION L'UTILISATION ET L'ENTRETIEND DE CE FOUR. S'IL VOUS PLAIT LISEZ-LE TRES ATTENTIVEMENT ET CONSERVEZ-LE.**

**LA NON-APPLICATION DE CES CONSIGNES ANNULE TOUTES GARANTIES.**

## SAFETY PROCEDURES AND PRECAUTIONS

Knowledge of proper procedures is essential to the safe operation of electrically and/or gas energized equipment. In accordance with generally accepted product safety labeling guidelines for potential hazards, the following signal words and symbols may be used throughout this manual.

### DANGER



Used to indicate the presence of a hazard that **WILL** cause severe personal injury, death, or substantial property damage if the warning included with this symbol is ignored.

### WARNING



Used to indicate the presence of a hazard that **CAN** cause personal injury, possible death, or major property damage if the warning included with this symbol is ignored.

### CAUTION



Used to indicate the presence of a hazard that can or will cause minor or moderate personal injury or property damage if the warning included with this symbol is ignored.

### CAUTION

Used to indicate the presence of a hazard that can or will cause minor personal injury, property damage, or a potential unsafe practice if the warning included with this symbol is ignored.

**NOTE:** Used to notify personnel of installation, operation, or maintenance information that is important but not hazard related.

1. This appliance is intended to cook, hold or process foods for the purpose of human consumption. No other use for this appliance is authorized or recommended.
2. This appliance is intended for use in commercial establishments where all operators are familiar with the purpose, limitations, and associated hazards of this appliance. Operating instructions and warnings must be read and understood by all operators and users.
3. Any troubleshooting guides, component views, and parts lists included in this manual are for general reference only and are intended for use by qualified technical personnel.
4. This manual should be considered a permanent part of this appliance. This manual and all supplied instructions, diagrams, schematics, parts lists, notices, and labels must remain with the appliance if the item is sold or moved to another location.

### NOTE

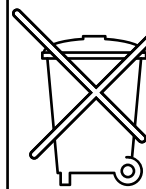

For equipment delivered for use in any location regulated by the following directive:

**DO NOT DISPOSE OF ELECTRICAL OR ELECTRONIC EQUIPMENT WITH OTHER MUNICIPAL WASTE.**

# INSTALLATION

## COMMON SPECIFICATIONS

AR-6G		
Overall height	78-1/8"	1983mm
Overall width	62-15/16"	1599mm
Overall depth	32-5/8"	828mm
Height Cooking cavity	53-3/4"	1365mm
- Pedestal	12-3/16"	309mm
- Overall	22-1/2"	571mm
Total weight, empty	974 lbs	442 kg

### ACCESSORIES USABLE SPACE (L X W X D)

- |   |          |
|---|----------|
| • <b>MULTI-PURPOSE BASKET,</b><br>(38.75" x 5.25" x 6.375") | SI-27510 |
| • <b>SHANK BASKET,</b><br>(38.75" x 4.75" x 5.5")           | SI-27506 |
| • <b>WHOLE PRODUCT SKEWER,</b><br>(38.75" x 5.25" x 5.5")   | SI-27508 |
| • <b>HEAVY DUTY "V" SKEWER,</b><br>(37" of usable length)   | 5005514  |
| • <b>ROASTING TRAY</b><br>(40.75" x 11.25" x 2.0")          | 5017274  |



Thirty Six (36) Chicken Roasting Unit

## ACCESSORIES

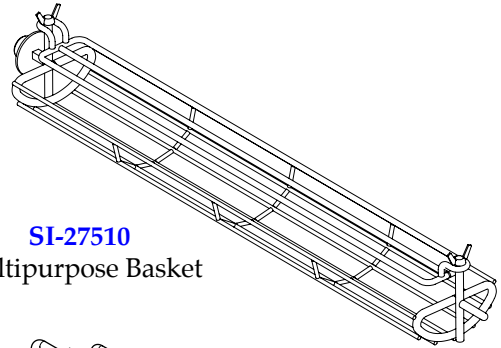

**SI-27510**  
Multipurpose Basket

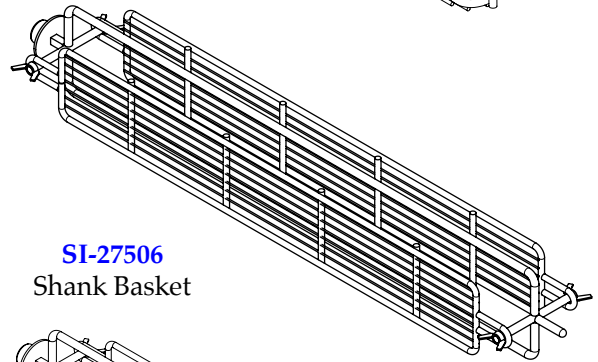

**SI-27506**  
Shank Basket

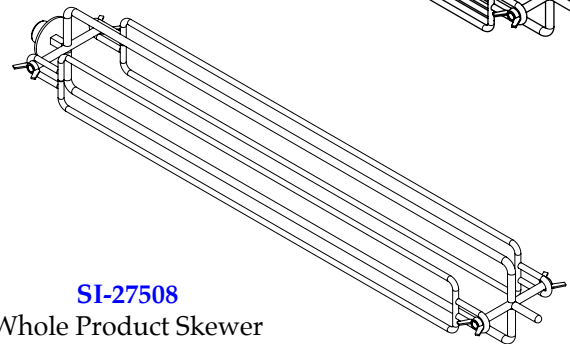

**SI-27508**  
Whole Product Skewer

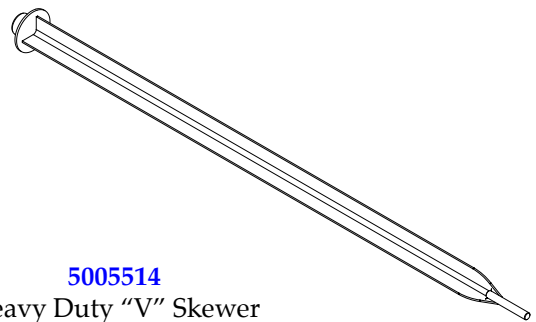

**5005514**  
Heavy Duty "V" Skewer

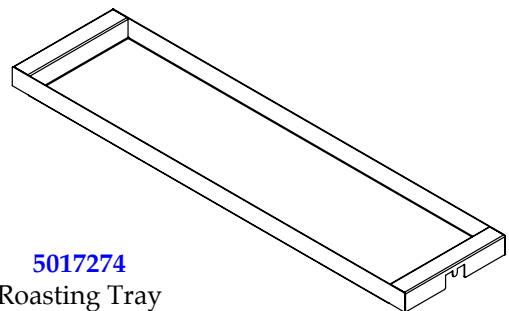

**5017274**  
Roasting Tray

# INSTALLATION

## TECHNICAL SPECIFICATIONS

### DIMENSIONS (H X W X D)

EXTERIOR: 78-1/8" x 62-15/16" x 32-5/8"  
(1983mm x 1599mm x 828mm)

INTERIOR: 53-3/4" x 50" x 12-11/16"  
(1365mm x 1193mm x 321mm)

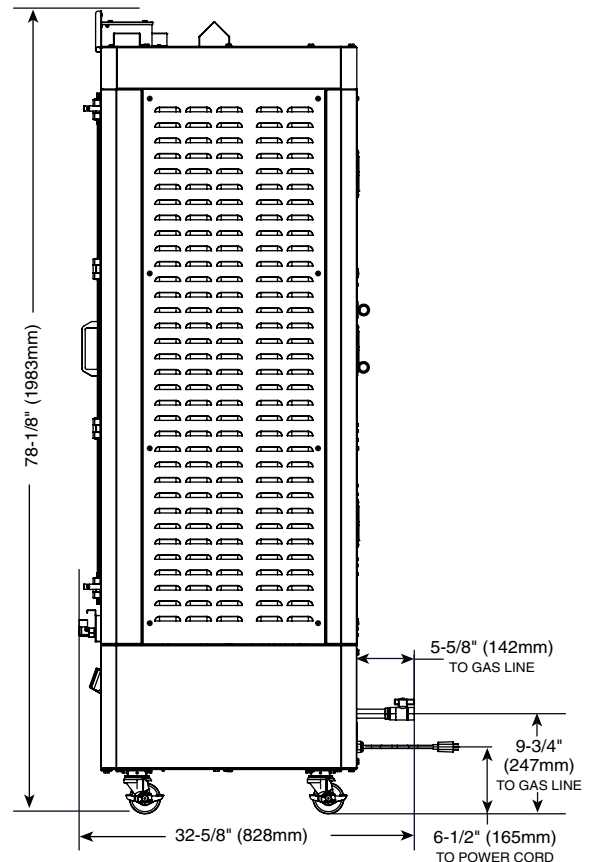
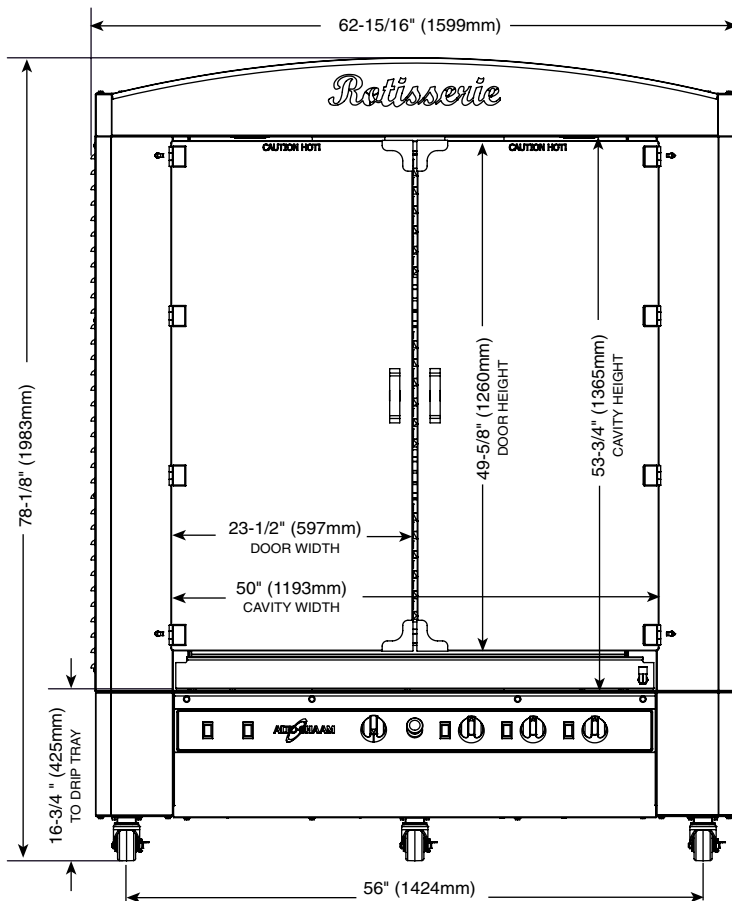
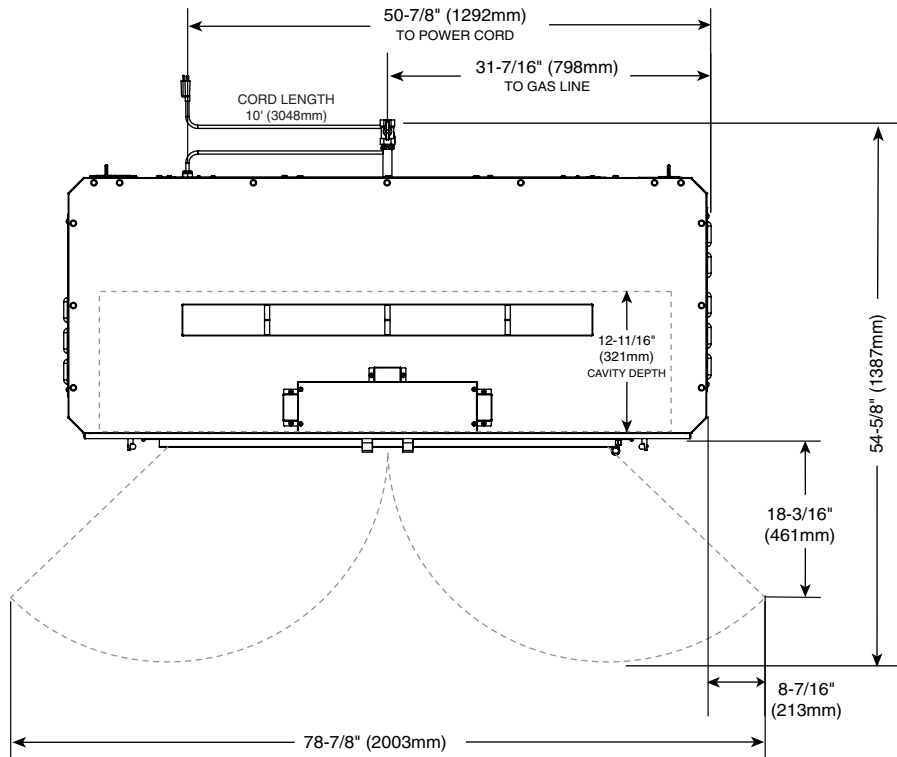

# INSTALLATION

## TECHNICAL COMPONENTS

SPITS		MOTOR SWITCH	
Number	6	Number	3
Usable length	37" (940mm)	BULBS	
DRIVING MOTORS		120V, 60W, INCANDESCENT	3
Number	6	12V, 20W, HALOGEN	3
Voltage, unit power	120V/60Hz	POWER CORD PLUG TYPE	
GAS BURNERS		2 prongs + ground	NEMA 5-15P 15A, 125V PLUG
Type: direct flame	Yes	CAPACITY	
Number	3	Bird	144 lb / 168 lb
UNIT POWER RATING		TOTAL ELECTRIC	
Propane	195,000 BTU	Consumption	6 AMPS
Natural	195,000 BTU		

## SITE INSTALLATION

### DANGER



IMPROPER INSTALLATION, ALTERATION, ADJUSTMENT, SERVICE, OR MAINTENANCE COULD RESULT IN SEVERE INJURY, DEATH, OR CAUSE PROPERTY DAMAGE.

READ THE INSTALLATION, OPERATING AND MAINTENANCE INSTRUCTIONS THOROUGHLY BEFORE INSTALLING OR SERVICING THIS EQUIPMENT.

### DANGER



AVERTISSEMENT : UNE INSTALLATION, UN AJUSTEMENT, UNE ALTÉRATION, UN SERVICE OU UN ENTRETIEN NON CONFORME AUX NORMES PEUT CAUSER DES DOMMAGES À LA PROPRIÉTÉ, DES BLESSURES OU LA MORT.

LIRE ATTENTIVEMENT LES DIRECTIVES D'OPÉRATION ET D'ENTRETIEN AVANT DE FAIRE L'INSTALLATION, OU L'ENTRETIEN DE CET ÉQUIPEMENT.

### CAUTION



THE APPLIANCE MUST REMAIN ON THE PALLET WHILE BEING MOVED TO THE INSTALLATION SITE BY FORK LIFT OR PALLET LIFT TRUCK.

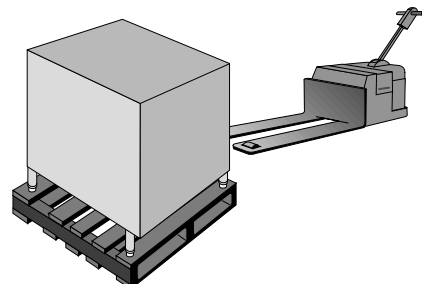
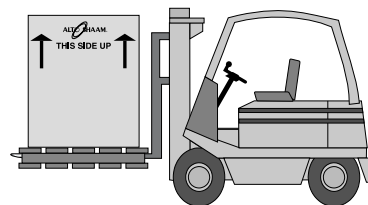

**NOTE:** Note dimensions required for doorways and aisles for access of the appliance and pallet to the installation site. Transport the appliance in an upright and level position only. **Do not tilt the appliance.**

# INSTALLATION

## SITE INSTALLATION

### INSTALLATION CODES & STANDARDS

The following codes and standards are required for installation of this appliance: **AIR SUPPLY, ELECTRICAL CONNECTIONS, WATER CONNECTIONS, GAS CONNECTIONS, GAS EXHAUST, AND WASTE WATER DISCHARGE.**

Installation must comply with local codes required for gas appliances. In the absence of local codes, installation must comply with the National Fuel Gas Code, ANSI Z223.1 (latest edition). In Canada, the appropriate code is the Natural Gas Installation Code, CAN/CGA-B149.1 or the Propane Installation Code, CAN/CGA-B. Adherence to code by a qualified installer is essential for the following: Gas Plumbing, Gas Appliance Installation, Commercial Cooking Ventilation, Water and Plumbing, and OSHA Regulations.

### STANDARD FOR GAS FOOD SERVICE EQUIPMENT

ANSI Z83, 11-2006/CSA 1.8 - 2006

The information contained in this manual is important for the proper installation, use and maintenance of this appliance. Please read carefully and retain for future reference. Improper connection of this appliance will nullify all warranties.



ANSI/NSF4

### VENTILATION REQUIREMENTS

A ventilation hood is mandatory for the operation of the appliance. The ventilation hood must be installed in accordance with local building codes for the steam exhaust and must protrude 12" to 20" (300 to 500mm) over the front side of the appliance. A grease filter must be located in the protruding area of the hood. Grease filters should be thoroughly cleaned on a regular basis following manufacturer's instruction. Ventilation hoods must ensure an adequate amount of incoming air during operation and must be operated whenever the appliance is used.

### POSITIONING ON SITE

Lift the appliance from the pallet with a fork lift or pallet lift truck positioned at the front of the appliance. For damage protection, the use of two wooden boards, placed between the bottom of the appliance and the lifting forks, is strongly recommended.

Stand the appliance in a level position. Use the adjustable casters to overcome an uneven floor and ensure that the unit is level.

To insure proper operation, the installation of this appliance must be completed by qualified technicians in accordance with the instructions provided in this manual. Failure to follow the instructions provided may result in damage to the appliance, building, or cause personal injury to personnel.

## CAUTION



**TO PREVENT PERSONAL INJURY,  
USE CAUTION WHEN MOVING OR  
LEVELING THIS APPLIANCE.**

### MINIMUM CLEARANCE REQUIREMENTS

<b>BOTH SIDES</b>	18" (457mm)
<b>BACK</b>	4" (102mm)
<b>TOP</b>	20" (508mm) FOR AIR MOVEMENT

## SITE INSTALLATION

### POSITIONING REQUIREMENTS

- In order to ensure proper ventilation, a minimum distance of at least 18" (457mm) must be kept from the side panels (left and right) of the appliance and any adjoining surfaces.

**NOTE:** If adequate service clearance is not provided, it will be necessary to disconnect the gas connection to move the appliance. Charges in connection with inadequate service access are not covered under warranty.

- Allow a minimum clearance of 4" (102mm) from the back of the appliance for gas plumbing connections.

- Allow a 20" (508mm) clearance at the top of the appliance for free air movement and for the vent(s) located at the top.
- Do not install the appliance adjacent to heat producing equipment such as fryers, broilers, etc. Heat from such appliances may cause damage to the Electrical Components of the appliance. Minimum clearance recommended: 20" (508mm)

Place the appliance on a stable, noncombustible level horizontal surface. Level the appliance front-to-back and side-to-side by means of the adjustable casters.

- Rear of unit should be slightly elevated via caster adjustment to allow the doors to remain open while operator is working in the unit.

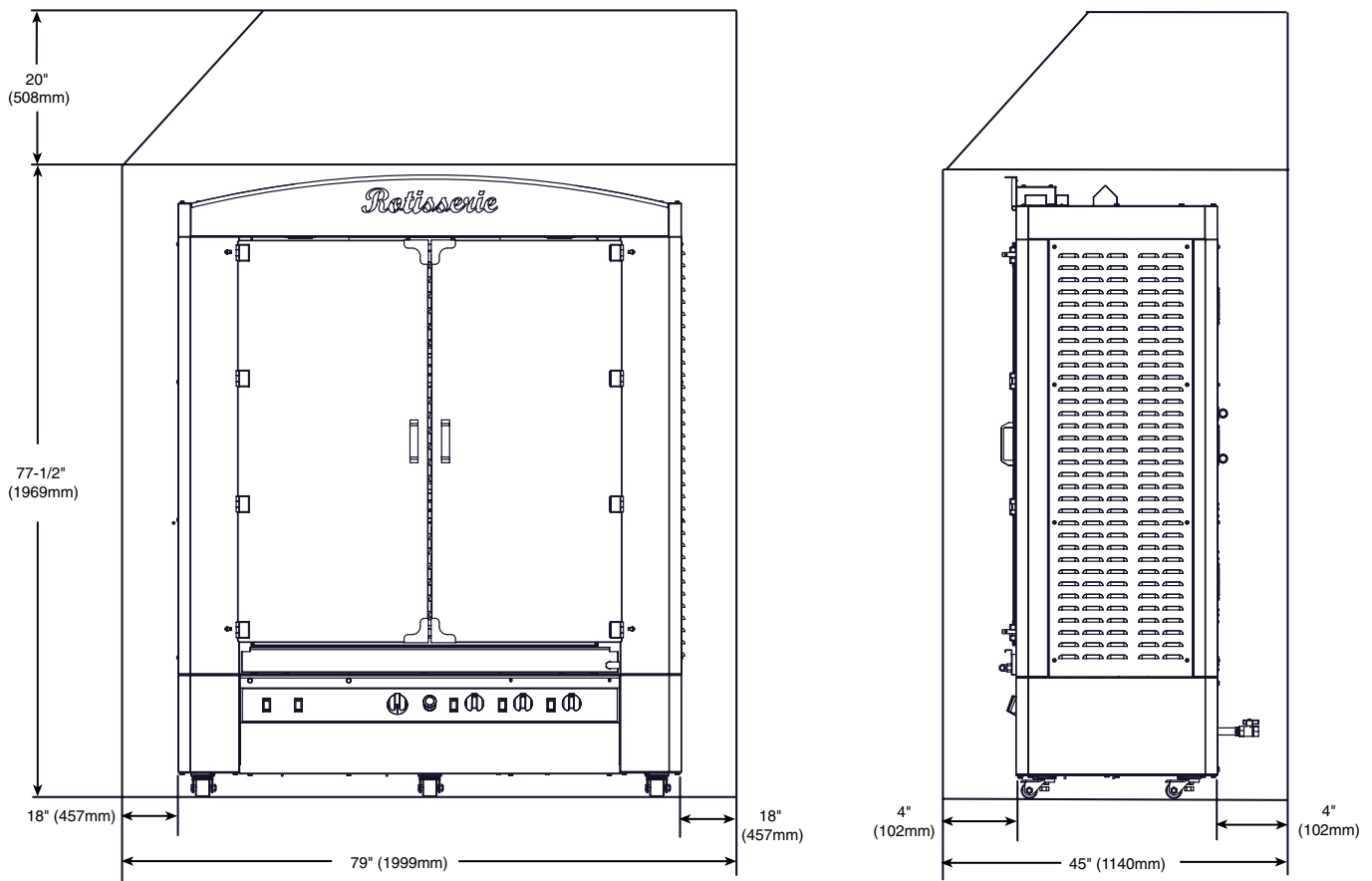

# INSTALLATION

## VENTILATION INSTRUCTIONS

### DANGER



**Installation, air adjustment and/or service work must be in accordance with all local codes and must be performed by a certified service technician qualified to work on gas appliances.**

An adequate ventilation system is required for commercial cooking equipment. Information may be obtained by writing to the National Fire Protection Association, Batterymarch Park, Quincy, MA 02269. When writing refer to NFPA No. 96.

1. A single gas appliance requires a minimum of 32 CFM make-up air for natural and propane gas. Kitchen ventilation must include a provision for an adequate flow of fresh air for gas combustion and to prevent a negative-pressure condition. The rear of the appliance provides air supply access for gas combustion and must be kept clear at all times. **DO NOT** obstruct or restrict ventilation nor the air flow required to support combustion.
2. **DO NOT** obstruct the flow of the exhaust flue at the top of the appliance. It is especially critical that gas supply piping and electrical support cord and/or receptacle be routed away from the path of the hot combustion fumes.

4. This appliance cannot be direct vented.
5. Install the appliance under a ventilation hood meeting all applicable code requirements. Combustion fumes must be vented in accordance with local, state, or national codes.

### CAUTION



**To prevent malfunction or cause negative back draft, DO NOT obstruct exhaust flues or attach any flue extension that will impede proper burner operation.**

3. Make certain the appliance installation maintains adequate air ventilation to provide cooling for electrical and gas components. The area around the appliance should be clear of any obstructions which might retard the flow of cooling air. Failure to observe this caution may result in damage to the components and will void the warranty.

### DANGER



**FAILURE TO VENT THIS APPLIANCE PROPERLY MAY BE HAZARDOUS TO THE HEALTH OF THE OPERATOR. Equipment damage, operational problems and unsatisfactory baking performance may also be the consequence of improper venting. Any damage sustained by a failure to properly vent this oven are not covered under warranty.**

### CAUTION



**DO NOT USE CIRCULATING FANS ON THE FLOOR. FLOOR FANS WILL AFFECT BURNER OPERATION.**

### WARNING



**Inadequate ventilation, or failure to ensure an adequate supply of fresh air will result in a high ambient temperature at the sides of the appliance. An excessive ambient temperature can cause the thermal-overload protection motor to trip resulting in severe damage to the cooling fans.**

Ventilating hoods and exhaust systems shall be permitted to be used to vent appliances installed in commercial applications.

Where automatically operated appliances are vented through a ventilating hood or exhaust system equipped with a damper or with a power means of exhaust, provisions shall be made to allow the flow of gas to the main burners only when the damper is open to a position to properly vent the appliance and when the power means of exhaust is in operation. **IN ACCORDANCE WITH NFPA 54 COMMONWEALTH OF MASSACHUSETTS ONLY.**

# INSTALLATION

## ELECTRICAL

An electrical wiring diagram is located under the access panel beneath the drip tray of the appliance. This appliance must be branch circuit protected with proper ampacities, in accordance with the wiring diagram located in the electrical compartment of the appliance. The appliance must be properly grounded in accordance with the National Electrical Code and applicable local codes.

Wire size for the main incoming power to the unit must match the minimum size listed in the specifications applicable to the specific appliance.

ELECTRICAL					
VOLTAGE	PHASE	CYCLE/HZ	AMPS	KW	
120	1	60	6.0	0.7	 NEMA 5-15P 15A, 125V PLUG

Wire diagrams are located in the inside access panel of the unit.

## DANGER



### ELECTRICAL GROUNDING INSTRUCTIONS:

This appliance is equipped with a three-pronged (grounding) plug for your protection against shock hazard and should be plugged directly into a properly grounded three-prong receptacle. Do not cut or remove the grounding prong from this plug.

## DANGER



**AVERTISSEMENT:** Directives pour la prise de courant électrique Cet appareil est muni d'une fiche à trois branches (prise de Courant) afin de vous protéger des chocs et doit être branché Directement dans un receptacle adéquate de prise de courant à trois branches. Il ne faut pas couper ou enlever une branche De cette fiche.

## DANGER



To avoid electrical shock, this appliance **MUST** be adequately grounded in accordance with local electrical codes or, in the absence of local codes, with the current edition of the National Electrical Code ANSI/NFPA No. 70. In Canada, all electrical connections are to be made in accordance with CSA C22.1, Canadian Electrical Code Part 1 or local codes.



## DANGER



**ENSURE POWER SOURCE MATCHES VOLTAGE IDENTIFIED ON APPLIANCE RATING TAG.**

# INSTALLATION

## AIR SUPPLY

### AIR SUPPLY

Installation of this appliance must include a provision for an adequate flow of fresh air for gas combustion. This requirement must be observed by the installer as well as the operator. The rear of the appliance provides air supply access for gas combustion and must be kept clear at all times

## CAUTION



**MAKE CERTAIN THE AREA AROUND THE REAR OF THE APPLIANCE IS KEPT CLEAR OF OBSTRUCTIONS TO ALLOW A CONTINUOUS SUPPLY OF FRESH AIR FOR GAS COMBUSTION.**

Make certain the installation maintains adequate air ventilation to provide cooling for electrical and gas components. The area around the appliance should be clear of any obstructions which might retard the flow of cooling air. Failure to observe this caution may result in damage to the control components and will void the warranty.

Local and the National Fuel Gas Code provide rules for determining the amount of fresh air necessary for combustion and ventilation of commercial cooking appliances. The codes will help determine if additional outside air may be necessary to meet health and safety regulations.

## CAUTION



**DO NOT USE CIRCULATING FANS ON THE FLOOR. FLOOR FANS WILL AFFECT BURNER OPERATION.**

## CAUTION



**CONVERSIONS MUST BE PERFORMED BY A CERTIFIED SERVICE TECHNICIAN QUALIFIED TO WORK ON GAS APPLIANCES.**

### AIR ADJUSTMENTS

The appliance can be field converted from one type of gas to another (natural gas to propane or vice versa).

#### OPTIONAL CONVERSION KITS

Natural Gas to Propane	5008903
Propane to Natural Gas	5008904

After taking the necessary safeguards for the gas circuit by employing the shut-off valve located at the rear of the appliance, and disconnect the appliance from the electric supply. Open the right-hand machine compartment.

Replace orifices as shown in chart.

Replace valves located under access panel.

Set manifold pressure as shown in chart.

If any gas fittings are loose or have been replaced, perform the following test:

- Use a soap and water solution to check all fittings for leaks. Brush solution on all joints or areas where a leak may be present. If bubbles appear, re-tighten the fitting and recheck. If bubbles persist, replace the fitting.

Always reconnect the gas line and inspect for leaks before replacing access panels.

	NATURAL	PROPANE
Top Orifice	OR-28127 # 29	OR-28132 # 43
Middle Orifice	OR-28128 # 20	OR-28191 # 41
Bottom Orifice	OR-28129 # 1	OR-28130 # 38
Manifold Pressure	5.0 $\mu$ /wc	10.0 $\mu$ /wc

# INSTALLATION

## GAS CONNECTIONS

This gas appliance has been set to operate with either natural gas or propane as indicated on the identification name plate. Make certain the gas supply matches the nameplate information. Should conversion to the opposite fuel be desired, conversion parts must be ordered from the factory. Conversion must be completed by a qualified service person only. Always remember to reflect the conversion on the nameplate.

### CAUTION



**RESIDENTIAL GAS CONNECTIONS  
AND HARD-PIPED GAS CONNECTIONS  
DO NOT MEET NSF CERTIFICATIONS**



### DANGER



**CONNECTING TO THE WRONG GAS  
SUPPLY COULD RESULT IN FIRE OR  
AN EXPLOSION CAUSING SEVERE  
INJURY AND PROPERTY DAMAGE.**

### GAS SPECIFICATIONS

	NATURAL GAS	PROPANE GAS
AR-6G	195,000 Btu/hr.	195,000 Btu/hr.

### INSTALLATION REQUIREMENTS

GAS CONNECTION: 3/4" NPT

CHECK PLUMBING CODES FOR PROPER SUPPLY LINE SIZING TO ATTAIN MINIMUM BURNER MANIFOLD PRESSURE SHOWN:  
**NATURAL GAS: 5" W.C.**  
**PROPANE GAS: 10" W.C.**

MAXIMUM INLET PRESSURE: 14" W.C.

**NOTE:** If a flexible gas line is used, it must be AGA approved, commercial type and at least 3/4" I.D.

HOOD INSTALLATION IS REQUIRED

GAS VALVE MAY REQUIRE FIELD ADJUSTMENT ABOVE 3,250' (991m) AND IS NOT ADJUSTED AT THE FACTORY.

## WARNING



**TO AVOID SERIOUS PERSONAL INJURY, installation of this appliance must conform to local, state, and national codes; the current edition of the American National Standard Z223.1, National Fuel Gas Code, and all local municipal building codes. In Canada, installation must be in accordance with Standard CAN/CSA B 149.1 and Installation Codes - Gas Burning Appliances, and local codes.**

### GAS PRESSURE CHART

The appliance has been factory adjusted according to the gas type specified on the identification name plate.

#### TECHNICAL SPECIFICATIONS

##### Natural Gas

Min. Connected Pressure	7.0" W.C.	1.12 kPa
Max. Connected Pressure	14.0" W.C.	3.5 kPa

##### Propane Gas

Min. Connected Pressure	11.0" W.C.	1.99 kPa
Max. Connected Pressure	14.0" W.C.	3.5 kPa

# INSTALLATION

## GAS CONNECTIONS

The installation of this appliance must be completed by a qualified installer familiar with the local codes and regulations governing the installation of commercial gas appliances. The installation must be made in accordance with local codes or, in the absence of local codes, with the National Fuel Gas Code ANSI Z223.1 (latest edition). In Canada, the appropriate code is the Natural Gas Installation Code, CAN/CGA-B149.1 or the Propane Installation Code, CAN/CGA-B149.2.

- ❑ Both the appliance and the individual appliance shutoff valve must be disconnected from the gas supply piping system during any pressure testing of that system at test pressures in excess of 1/2 psi (3.45 kPa).
- ❑ The appliance must be isolated from the gas supply piping system by closing the individual appliance manual shutoff valve during any pressure testing of the gas supply piping system at test pressures equal to or less than 1/2 psi (3.45 kPa).

Close the individual manual shut-off valve to isolate the appliance from the gas supply piping system during any pressure testing at test pressures equal to or less than 1/2 psig. (3,4 kPa). The appliance and individual shut-off valve must be disconnected from the gas supply piping system during any pressure testing at pressures in excess of 1/2" psig. (3,4 kPa).

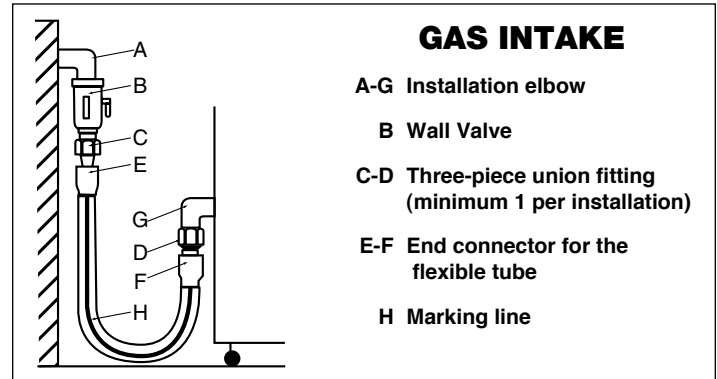

**DANGER**

Installation, air adjustment and/or service work must be in accordance with all local codes and must be performed by a certified service technician qualified to work on gas appliances.

**DANGER**

DO NOT store or use gasoline or other flammable vapors or liquids in the vicinity of this or any other appliance.

**DANGER**

NE PAS entreposer ni utiliser d'essence ou d'autres vapeurs ou liquides inflammables à proximité de cet appareil ou de tout autre appareil.

Use an approved gas pipe sealant at all external threaded connections. Gas piping used on gas connections must avoid sharp bends that may restrict the flow of gas to the appliance. If the connected pressure exceeds 14.0" W.C. (3.5 kPa), a step-down regulator is required to be supplied by the owner/operator.

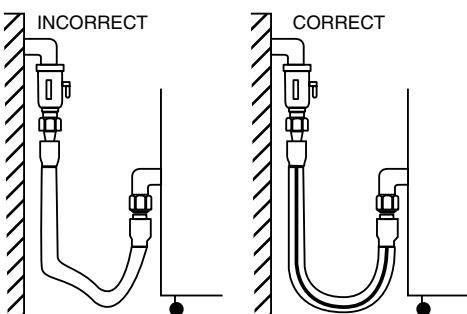

In the U.S.A., installation must conform to local codes or, in the absence of local codes, with the current edition of the National Fuel Gas Code, NFPA-54 and ANSI Z83.11a CSA 1.8a 2004 (or latest edition). In Canada, installation must be in accordance with local codes, CAN/CGA-B149.1, Installation for Natural Gas Burning Appliances and Equipment (latest edition) or CAN/CGAB149.2 Installation for Propane Burning Appliances and Equipment (latest edition).

The inlet supply line must be properly sized to accommodate all individual appliances simultaneously used on the same line but must never be smaller than 3/4" NPT.

# INSTALLATION

## GAS CONNECTIONS

The minimum size of the gas piping or flexible connector is 3/4" (19mm). For long runs of gas piping, the pipe diameter must conform to the tables in the National Fuel Gas Code, ANSI/NFPA Z223.1

A listed gas shut off valve must be installed upstream of the appliance for shutting off the gas supply while servicing. This valve should be installed so that it is accessible with the appliance in the normally installed position.

The appliance is supplied with casters, therefore, installation must be made with a flexible connector that complies with the Standard for Connectors for Movable Gas Appliances, ANSI Z21.69; or in Canada, Connectors for Movable Gas Appliances, CAN/CGA-6.16-M87. When using a flexible connector, a quick disconnect device must also be used that complies with the Standard for Quick-Disconnect Devices for Gas Fuels, ANSI Z21.41; or in Canada, Quick Disconnect Devices for Use with Gas Fuels, CAN1-6.9.

When a quick disconnect device and flexible connector are used, a restraining device must be installed to limit the movement of the appliance in order to prevent damage to the connector or quick disconnect. An example of such a system uses 2000 pound test stainless steel cable attached to a structural member of the kitchen wall behind the unit. The attachment means must include a quick connect snap that can be disconnected when the appliance must be moved away from the wall. The other end of the cable should be permanently attached to the rear frame of the appliance. The cable should be of sufficient length so that no strain is ever placed upon the flexible gas connector if the appliance is accidentally moved without initially disconnecting the gas connector.

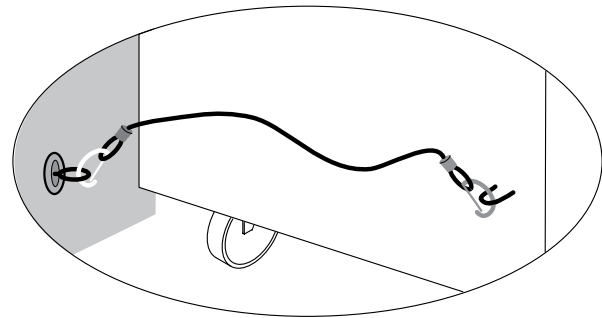

**GAS PIPING MUST NEVER BE INSTALLED TO RUN UNDER THE BURNER.**

The flexible connector should be routed to form a downward "U" loop between the building gas supply and the permanent attachment at the rear of the oven.

The routing of the flexible connector must not be made under the oven. Oven temperatures achieved during operation are too hot for safe operation. Gas piping should be installed from the point of gas connection at the bottom, front of the oven to the back of the oven where the flexible connector may be safely used. See the illustration for the recommended placement.

## WARNING



**GAS PIPING MUST NEVER BE INSTALLED TO RUN UNDER THE BURNER.**

## SECURING ELECTRICAL ACCESS COVER

After gas pressure has been set and leak testing performed, the electrical access cover located under the drip tray inside the unit must be sealed with a High-Temperature NSF Approved RTV adhesive prior to cooking in the unit.

Secure the electrical access panel by applying the High-Temperature NSF Approved RTV adhesive to each of the 14 bolts (provided with unit) and tighten down. Next run a bead of the High-Temperature NSF Approved RTV adhesive around the electrical access panel and smooth in place. Wipe excess RTV adhesive off.

# INSTALLATION

## LEAK TESTING

If a pressure leak test above 1/2 psi is to be conducted on the building supply gas piping, the shutoff gas valve and appliance inlet gas supply line must be disconnected from the building supply piping before conducting the pressure test. Failure to do so may result in damage to the manual gas valve and/or gas components in the appliance.

If any gas leak tests are to be conducted at pressures equal to or below 1/2 psi, the manual gas shut off valve upstream of the appliance must be turned off before conducting the tests.

Leak testing of the internal appliance piping system was conducted before shipping the appliance from the factory. If additional testing is needed, it should only be conducted at normal gas supply pressures. If the testing is performed using combustible gas in the piping, leak testing should be done with a soap solution (bubble checking) or other approved liquid.

The use of an electronic combustible gas leak detector is

helpful; however, this type of detector can be oversensitive. Electronic detectors may indicate false leaks from other sources which would not be detected when checking with a liquid solution to verify a no-hazard gas connection.

When starting the appliance after initial installation, the gas lines must be free of air which may take up to 30 minutes to purge from supply line. If the burners do not light after this period of time, call factory for assistance.

<b>⚠ DANGER</b>	
	<b>NEVER USE AN OPEN FLAME TO LEAK TEST.</b>

## GAS EXHAUST

The appliance is not to be directly connected to a chimney vent system nor directly connected to a horizontal exhaust system. The unit must be installed under a ventilation hood listed as ANSI/UL 705 (latest edition), and the installation must be conducted in accordance with the ANSI/NFPA 96-1987, Standard for Ventilation Control and Fire Protection of Commercial Cooking Operations.

Operators of the appliance should be instructed not to place any material on top of the appliance that would obstruct the flow of flue products from the opening. Operators should also be instructed that flue gases are hot and any material or items placed on top or in front of the flue deflector could be damaged or cause a fire hazard.

<b>DANGER</b>	
	<b>BEFORE STARTING THE APPLIANCE, MAKE CERTAIN YOU DO NOT DETECT THE ODOR OF GAS.</b>
	<b>IF THE ODOR OF GAS IS DETECTED:</b>
	<ul style="list-style-type: none"><li>• <b>DO NOT</b> attempt to light any appliance.</li><li>• <b>DO NOT</b> touch any electrical switches.</li><li>• <b>Extinguish</b> any open flame.</li><li>• <b>Use a telephone OUTSIDE THE PROPERTY &amp; IMMEDIATELY contact your gas supplier.</b></li><li>• <b>If unable to contact your gas supplier, contact the fire department.</b></li></ul>

## IGNITION SYSTEM

This unit is equipped with "direct spark ignition" for ease of lighting the burners.

The electrodes are located just above the burner under the burner cover on the right hand side of the appliance. These electrodes are very fragile and care must be taken if adjustment is required. Special care must be used to prevent breakage of the porcelain insulator.

If the porcelain is damaged or broken, the igniter assembly must be replaced. The end of the electrode must have a gap of 1/8" to 3/16" (3mm to 5mm) from the top surface of the burner. The spark must be maintained between the electrode and the burner for proper ignition.

# OPERATING INSTRUCTIONS

## BURNER LIGHTING INSTRUCTIONS

Verify appliance connection to the correct gas source. Refer to the data plate located on the back of the unit.

**NOTE:** Use soap and water solution to check all fittings for leaks. Brush solution on all joints and where any leakage is suspected. If bubbles appear, re-tighten the fitting and recheck. If bubbles persist, replace fitting or component.

*Verify that the manual gas shut-off valve at the back of the appliance is in the open position.*

The appliance is equipped with three cooking zones: lower, middle, and top burners.

### RECOMMENDED LIGHTING SEQUENCE

Natural Gas: TOP MIDDLE BOTTOM

Propane Gas: BOTTOM MIDDLE TOP

### TO LIGHT THE BURNERS:

1. Select corresponding gas valve knob. Rotate the knob to the ignite position. (H=High)
2. If the burner fails to ignite after 5-seconds, turn valve to the OFF position. Open the doors to allow the gas to dissipate and repeat the ignition process.
3. After burner has ignited, rotate the gas valve to flame height desired for cooking.

### TO SHUT OFF BURNERS:

Rotate the gas valve knob to the OFF position.

## CAUTION



**IN AN EMERGENCY, PRESS THE EMERGENCY STOP BUTTON LOCATED ON THE FRONT CONTROL PANEL. THEN CLOSE THE SHUT-OFF VALVE LOCATED IN THE REAR OF THE UNIT.**

**NOTE:** Following initial installation, it may take slightly more time to evacuate the excess air from the supply lines.

## CAUTION



**Propane is a heavy gas and will settle on the floor or the lowest point in a building. If a raw gas smell is present, evacuate the building and contact your local fire department or safety agency for assistance.**

## WARNING



**In the event of loss of power to the appliance, turn the "burner control knobs" to the OFF position. Remove food product from the unit. If burner control fails to extinguish the flame, shut off main gas valve located in rear of unit.**

### GAS FLAME PATTERNS

When starting the appliance after initial installation, the gas lines must be free of air pockets. It may take up to 30 minutes to free the lines. If, after this time there is no ignition, call for factory assistance.

For all practical purposes, the following will be the only check necessary during initial operation by the installer. After the installation is complete the appliance must be test fired to ensure that the system is operating properly. Follow the operating instructions posted on the front of the unit.

The flame pattern both under hot and cold conditions should be stable on all burner ports and there should be no lifting or blowing after several seconds of operation. There is an air shutter adjustment on these burners. If the flame pattern does not match that shown, contact the factory for further directions.

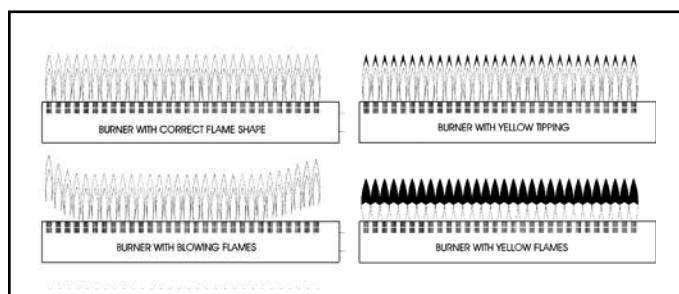

Make certain the electric igniter lights the burner quickly. The main burner should ignite within 5-seconds, smoothly, with no harsh noise or any problem. Make sure that the burner is lighting quickly from the electric igniter. Allow the appliance to heat for 5 minutes and repeat the process.

Check the flame pattern on the burners. When using natural gas, the flames should be blue in color with little or no yellow in the flame. On propane gas some yellow tipping is normal.

# OPERATING INSTRUCTIONS

## CONTROLS

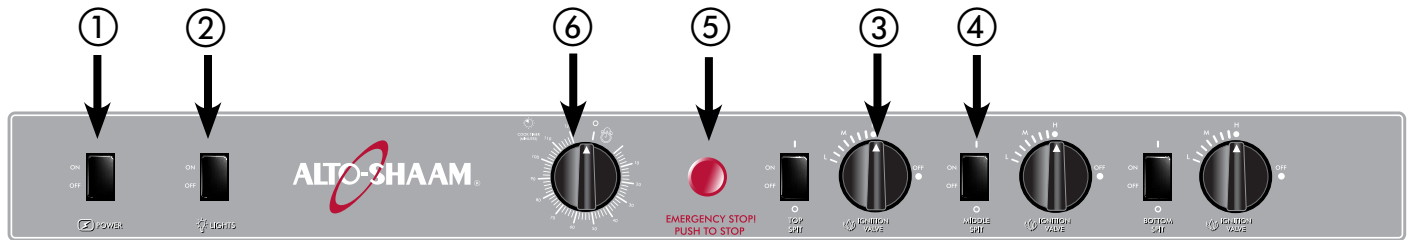

- 1 The **MAIN POWER** switch is located on the left side of the control panel.
- 2 The **LIGHT SWITCH** controls cook cavity and Rotisserie logo light.
- 3 **BURNER CONTROL AND CONTROL BURNER FLAME HEIGHT** is used to activate burner ignition modules and adjust flame height.
- 4 Spit Rotation switches are labeled **TOP, MIDDLE, and BOTTOM**. When in the **ON** position, each switch will activate the corresponding double set of spits for each switch.
- 5 **EMERGENCY STOP** is located in the center of the control panel which shuts down the system in an emergency.
- 6 **COOK TIMER** (2 hour maximum)

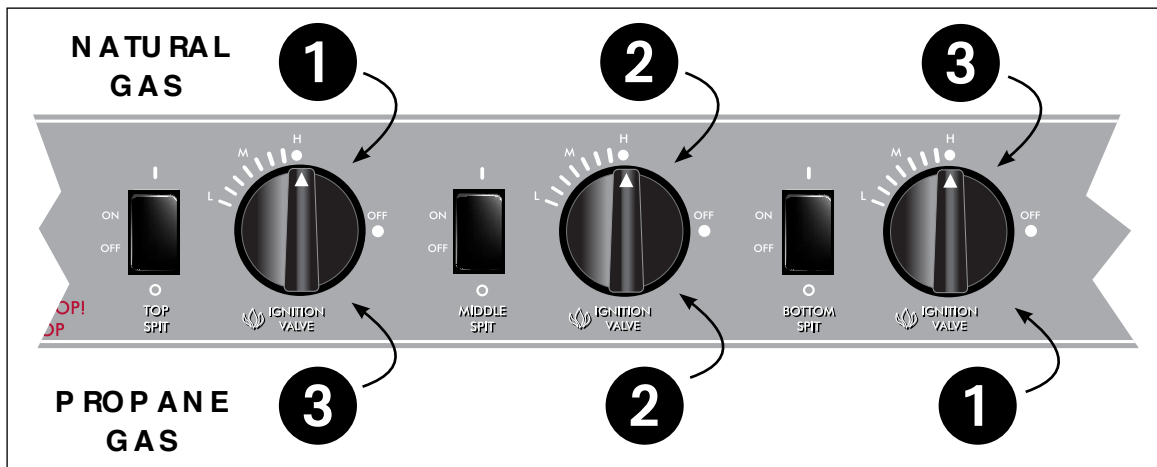

### TO LIGHT THE BURNERS:

1. Select corresponding gas valve knob. Rotate the knob to the ignite position. (H=High)
2. If the burner fails to ignite after 5-seconds, turn valve to the OFF position. Open the doors to allow the gas to dissipate and repeat the ignition process.
3. After burner has ignited, rotate the gas valve to flame height desired for cooking.

### TO SHUT OFF BURNERS:

Rotate the gas valve knob to the OFF position.

### RECOMMENDED LIGHTING SEQUENCE

Natural Gas: 1 TOP 2 MIDDLE 3 BOTTOM

Propane Gas: 3 BOTTOM 2 MIDDLE 1 TOP

## DOOR CATCH

A magnetic door catch is used to keep door closed.

# OPERATING INSTRUCTIONS

## PLACEMENT & ADJUSTMENT OF SPITS

To place the spit into the appliance insert the "T" shaped, SPIT DRIVE HUB ② on to the SPIT DRIVE SHAFT ①.

Turn the spit slightly to make certain it is correctly positioned. Place the opposite end of the spit on the SPIT RETAINING BRACKET ③

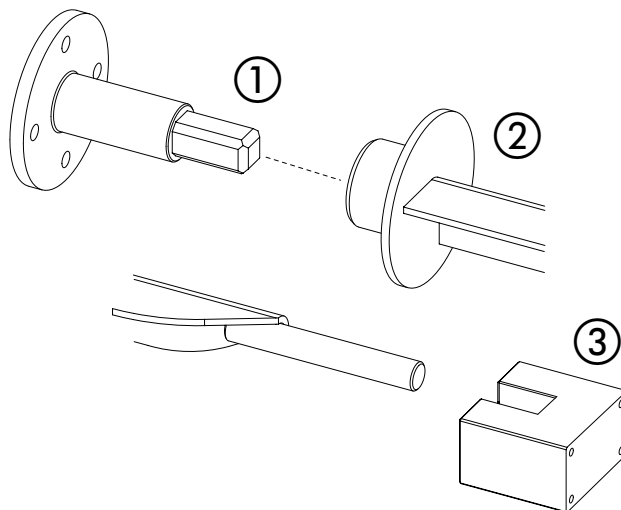

## NOTE

**BEFORE USING THE APPLIANCE FOR THE FIRST TIME THOROUGHLY CLEAN THE UNIT AS DIRECTED. ENGAGE ALL BURNERS AND OPERATE THE EMPTY APPLIANCE FOR A PERIOD OF 20 MINUTES TO BURN OFF ANY RESIDUE WHICH MAY BE ON THE METAL AS A RESULT OF THE MANUFACTURING PROCESS.**

## PRODUCT PREPARATION

For a more flavorful product, season the inside of each chicken prior to cooking. Operators may also want to consider the use of a marinade or the purchase of pre-marinated chickens. For best results, truss each bird prior to inserting on the spit.

To produce a more roasted appearance and additional flaming, the skin of each chicken can be pricked prior to insertion on the skewer. This procedure, however, will bubble the skin and produce additional spatter during cooking.

*USING A FROZEN PRODUCT IS NOT RECOMMENDED.*

## CAUTION



**ALWAYS USE HAND PROTECTION WHEN OPENING THE DOORS OR HANDLING SPITS WHENEVER THE APPLIANCE IS HOT.**

## CAUTION



**NEVER USE OR PLACE ALUMINUM FOIL IN THE APPLIANCE.**

## CAUTION



**FOR THE CORRECT OPERATION OF THE APPLIANCE AND TO HELP AVOID GREASE SPLATTER, THE WINDOW DOOR MUST BE CLOSED DURING COOKING.**

## CAUTION



**MAKE CERTAIN THE AREA AROUND THE REAR OF THE APPLIANCE IS KEPT CLEAR OF OBSTRUCTIONS TO ALLOW A CONTINUOUS SUPPLY OF FRESH AIR FOR GAS COMBUSTION.**

## NOTE

**TO FACILITATE CLEANUP, POUR WATER INTO THE DRIP PAN IN A SUFFICIENT AMOUNT TO COVER THE BOTTOM OF THE PAN. MAINTAIN THE WATER LEVEL THROUGHOUT THE COOKING PROCESS.**

# OPERATING INSTRUCTIONS

## SKEWER PREPARATION & LOADING

The appliance is furnished with six, removable skewers, each with 37" (940mm) of usable length. Average capacity per skewer is six 2-1/4 to 2-1/2 pound (1 to 1,1 kg) chickens up to 3-1/2 pounds (1,6 kg) per bird. If fewer chickens are used, space them evenly along the length of the spit. Insert the first bird, tail end first, on the end of the skewer opposite the SPIT DRIVE SHAFT.

### NOTE

**PREHEAT AT FULL FLAME FOR A MINIMUM OF 30 MINUTES BEFORE LOADING PREPARED SPITS.**

Slide the bird down along the spit toward the disc shaped end. Continue in the same manner for each additional bird. Make certain to leave 2" to 3" (51-76mm) of free space between the first bird and the disc end of the spit and the last bird and the round end of the spit. After preheating, properly insert each of the prepared spits into the appliance according to the method explained in this manual. Because heat rises, the chickens on the bottom spit will cook at a slower rate than those above.

When all spits are loaded and positioned, select and activate the geared motors with the spit rotation switches for each spit.

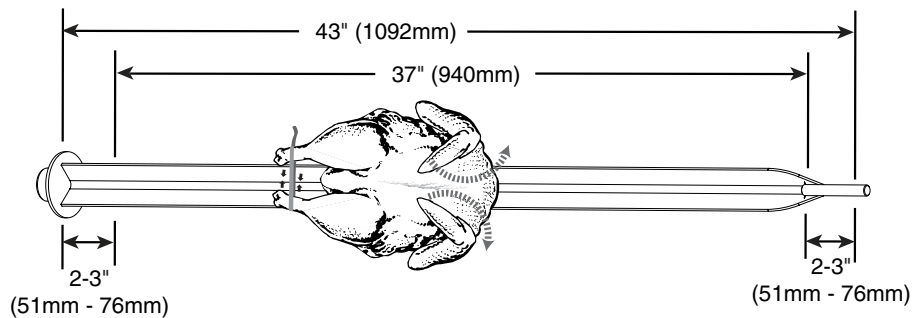

## COOKING TIME

Estimate a whole chicken roasting time of 60 to 75 minutes for cooking 3 to 3-1/2 lb (1,3 to 1,6 kg) birds and 50 to 60 minutes cook time for 2-1/2 lb (1,2 kg) birds. Time may need to be adjusted based on external climactic conditions, the adjustment of the spits, and the quality and size of the bird to be roasted.

For food safety, it is important to check the internal temperature of the cooked product with a clean and accurate thermometer. The temperature requirements for chicken are between 185° and 190°F (85° and 89°C). Juices should be clear and the joint where the drumstick meets the body should be loose.

When the chickens are fully cooked, remove the spit from the appliance and slide each bird off the spit with a large fork. Cooked chickens must be immediately placed in a controlled holding environment at or above 140°F (60°C).

### ADDITIONAL PRODUCT ROASTING TIMES

Chicken Halves or Pieces	35 to 40 minutes
Pork Roast	50 minutes
Turkey	50 minutes
Veal Breast	45 minutes
Ham Hocks/ Shanks	45 to 50 minutes

## CAUTION



**ALWAYS USE HAND PROTECTION WHEN OPENING THE DOORS OR HANDLING SPITS WHENEVER THE APPLIANCE IS HOT.**

# CARE AND CLEANING

## EQUIPMENT CARE



The cleanliness and appearance of this equipment will contribute considerably to operating efficiency and savory, appetizing food. Good equipment that is kept clean works better and lasts longer.

### CAUTION



**Always follow appropriate state or local health (hygiene) regulations regarding all applicable cleaning and sanitation requirements for equipment.**

## DAILY CLEANING

1. Turn the burners OFF, disconnect unit from power source and allow the appliance to cool.
2. Using hand protection, remove all detachable items such as spits. Clean these items separately with a good grease solvent or commercial detergent. Rinse well and dry.
3. With the appliance still warm (not hot), wipe the inside walls and the base with a damp cloth or sponge and any good alkaline or alkaline based commercial detergent at the recommended strength.
4. Spray heavily soiled areas with a water soluble degreaser and let stand for 10 minutes, then remove soil with a plastic scouring pad. Rinse by wiping with a sponge and clean warm water to remove all residue. Remove excess water with sponge and wipe dry with a clean cloth or air dry.

**NOTE:** Avoid the use of abrasive cleaning, compounds, chloride based cleaners, or cleaners containing quaternary salts. Never use hydrochloric acid (muriatic acid) on stainless steel.

5. Clean control panel and, door handles thoroughly since these areas harbor food debris. Rinse by wiping with sponge and clean warm water. Wipe dry with a clean cloth.
6. Clean the interior walls at cooking zone, glass doors, and the lights with the same solution used for the inside of the appliance. Follow with an appropriate commercial glass cleaner.
7. Using hand protection, remove, empty, and clean the drip tray. Use caution since the drip tray and contents may be extremely hot. Wipe around the electrical access cover.
8. Wipe the front and top of the appliance.

### CAUTION



**METAL PARTS OF THIS EQUIPMENT BECOME EXTREMELY HOT WHEN IN OPERATION. TO AVOID BURNS, ALWAYS USE HAND PROTECTION WHEN OPERATING THIS APPLIANCE.**



### DANGER



**DISCONNECT UNIT FROM POWER SOURCE BEFORE CLEANING OR SERVICING.**

### DANGER



**AT NO TIME SHOULD THE INTERIOR OR EXTERIOR BE STEAM CLEANED, HOSED DOWN, OR FLOODED WITH WATER OR LIQUID SOLUTION OF ANY KIND. DO NOT USE WATER JET TO CLEAN.**



**SEVERE DAMAGE OR ELECTRICAL HAZARD COULD RESULT. WARRANTY BECOMES VOID IF APPLIANCE IS FLOODED**

## CARE AND CLEANING



### DANGER



**DISCONNECT UNIT FROM POWER SOURCE BEFORE CLEANING OR SERVICING.**

### CAUTION

**THIS SECTION IS PROVIDED FOR THE ASSISTANCE OF QUALIFIED SERVICE TECHNICIANS ONLY AND IS NOT INTENDED FOR USE BY UNTRAINED OR UNAUTHORIZED SERVICE PERSONNEL.**

## CLEANING & RESEASONING CAST IRON TILES

1. Turn the burners OFF, disconnect unit from power source and allow the appliance to cool.
2. Using hand protection, remove all cast iron tiles.
3. Using a wire brush clean off any extra food debris.  
**NOTE:** DO NOT soak tiles in water or use soap. This may cause rusting to occur.
4. Spray each tile with cooking spray to preseason.
5. Replace the cast iron tiles.
6. Turn the units power back on and start the burners.
7. Run through a normal cooking cycle.
8. Repeat steps 1-7 as necessary.

## MAINTENANCE

### CHANGING OF LIGHT BULBS

The gas appliance is furnished with three 20 watt halogen bulbs. These bulbs should be replaced with the exact duplicate or a factory recommended replacement. The logo area is furnished with three 120 volt, 60 watt bulbs.

### CAUTION



**DO NOT HANDLE NEW BULB WITH BARE HANDS. WHITE COTTON GLOVES SHOULD BE WORN WHEN REPLACING BULBS.**

### OPENING MACHINE COMPARTMENTS

Prior to opening the various sections, disconnect the electrical supply and close the gas valve located on the rear of the appliance.

The electric motor compartment is located at the left and the gas burner controls at the right of the appliance. The gas valves and intake manifold assembly along with various electrical switches are located behind the control access panel. These compartments allow access for the repair of various components of the electrical and gas circuits.

#### Left and Right Access Panels

- Using a screwdriver, remove the various screws holding the required outside panel and remove the panel.
- When the repair has been completed, the panel must be remounted and the screws tightened.

#### Control Access Panel

(For access to control panel components)

- Remove drip tray assembly.
- Remove bolts that secure access panel.
- Remove access panel.

When the repair has been completed, perform the above described operation in reverse. Seal the cover in place with an approved silicone sealant (see page 14).

#### Rear Access Panel

(For access to electrical components)

- Remove 2 screws from rear access panel.
- Tip access panel back.

**TROUBLESHOOTING GUIDE**

<b>DEFECT OBSERVED</b>	<b>POSSIBLE CAUSE</b>	<b>REMEDY</b>
<b>ELECTRICAL</b>		
Spits and lamps do not work	No power supply to unit.	Verify unit has power to it. Reset circuit breaker.
Interior light off but spits work	Defective bulb.	Replace bulb.
One spit is not turning	Defective motor.	Contact manufacturer for replacement.
One or all spits not turning	Defective switch or power supply.	Contact manufacturer for replacement.
<b>GAS CIRCUIT</b>		
None of the burners are lighting	Gas shutoff is in OFF position. Flexible gas line not connected. Safety switch is not working.	Check main supply. Open closed valve. Reconnect gas line. Reset safety switch.
One burner heats irregularly or not at all	Burner orifices are clogged. Inlet pressure too low.	Clean or replace. Contact qualified gas specialist.



Alto-Shaam has established a twenty-four hour emergency service call center to offer immediate customer access to a local authorized service agency outside of standard business hours. The emergency service access is provided exclusively for Alto-Shaam equipment and is available throughout the United States through the use of Alto-Shaam's toll-free number. Emergency service access is available seven days a week including holidays.

# SERVICE

## FULL ASSEMBLY - FRONT VIEW

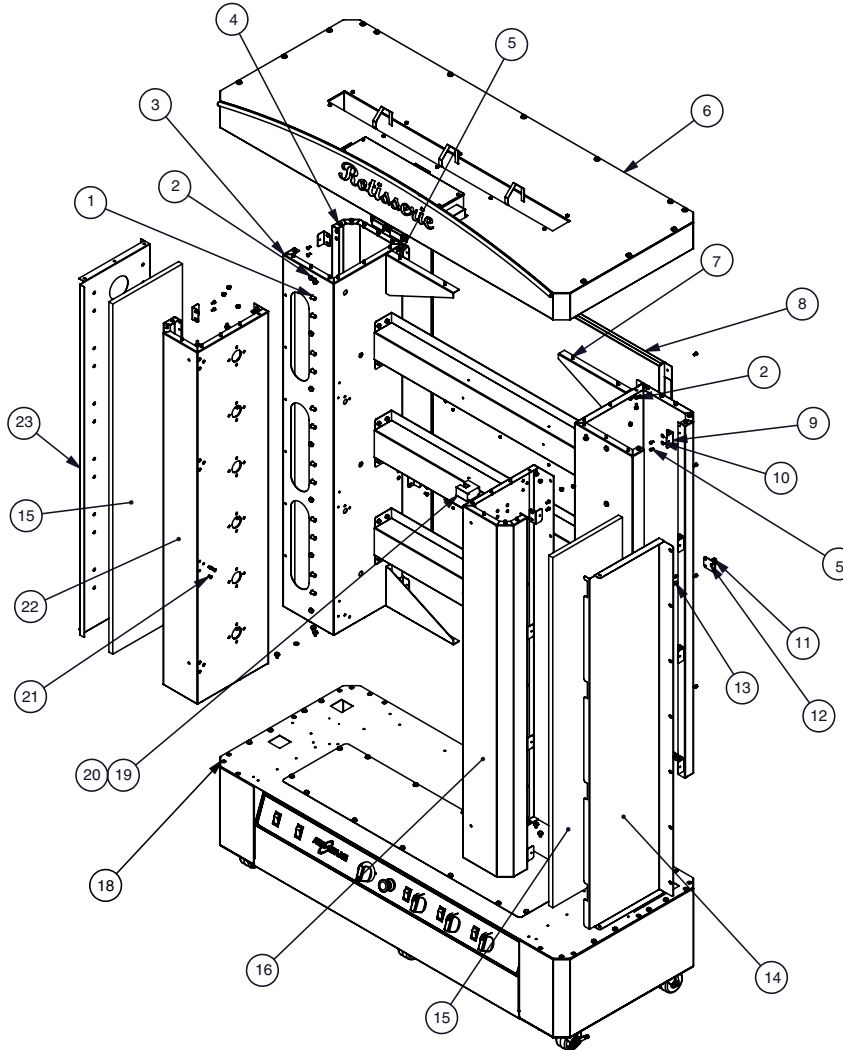

ITEM	PART NO.	DESCRIPTION	QTY	ITEM	PART NO.	DESCRIPTION	QTY
1	<a href="#">NU-24613</a>	1/4-20 INSERT NUT	24	13	<a href="#">HG-22672</a>	10-32 THREADED INSERT	8
2	<a href="#">WS-22094</a>	WASHER, 1/4", FLAT, 5/8 OD 18-8 SS	103	14	1009297	INSULATION COVER RIGHT	1
3	5008156	SIDE PANEL ASSEMBLY (S/S)	1	15	<a href="#">IN-24588</a>	INSULATION, 1" THICK CER. WOOL	2
	5005240	SIDE PANEL ASSEMBLY (BLK)	1	16	5005520	MOTOR PANEL RIGHT SPOT (S/S)	1
4	<a href="#">NU-2437</a>	NUT, 1/4-20 HEX S/S	32		PE-27605	MOTOR PANEL RIGHT SPOT (BLK)	1
5	SC-28434	SCREW, 10-32 X 3/8" HEX HD, S/S	56	17	5008154	BOTTOM ASSEMBLY (S/S)	1
6	5008155	TOP ASSEMBLY (S/S)	1		5005238	BOTTOM ASSEMBLY (BLK)	1
	<a href="#">5005245</a>	TOP ASSEMBLY (BLK)	1	18	<a href="#">BG-27596</a>	SPIT BEARING	6
7	<a href="#">SC-22729</a>	SCREW 1/4-20 X 1/2" HEX HEAD	103	19	<a href="#">SC-22378</a>	8-32 X 3/8" TRUSS HEAD SCREW	24
8	<a href="#">5005517</a>	BACK COVER ASSEMBLY	1	20	NU-28107	INSERT NUT #8-32 UNC	24
9	1006537	REAR COVER BRACKET	24	21	5005519	MOTOR PANEL LEFT SPOT (S/S)	1
10	WS-23672	WASHER, FLAT, #10, 18-8 S/S	48		PE-27602	MOTOR PANEL LEFT SPOT (BLK)	1
11	<a href="#">BT-26884</a>	BRACKET, TETHER.	2	22	1006541	INSULATION COVER LEFT	1
12	<a href="#">SC-23670</a>	SCREW, 10-32 X 1/2, NF PHIL, FLAT	8				

Part numbers and drawings are subject to change without notice.

**FINAL FLOOR ASSEMBLY - FRONT VIEW**

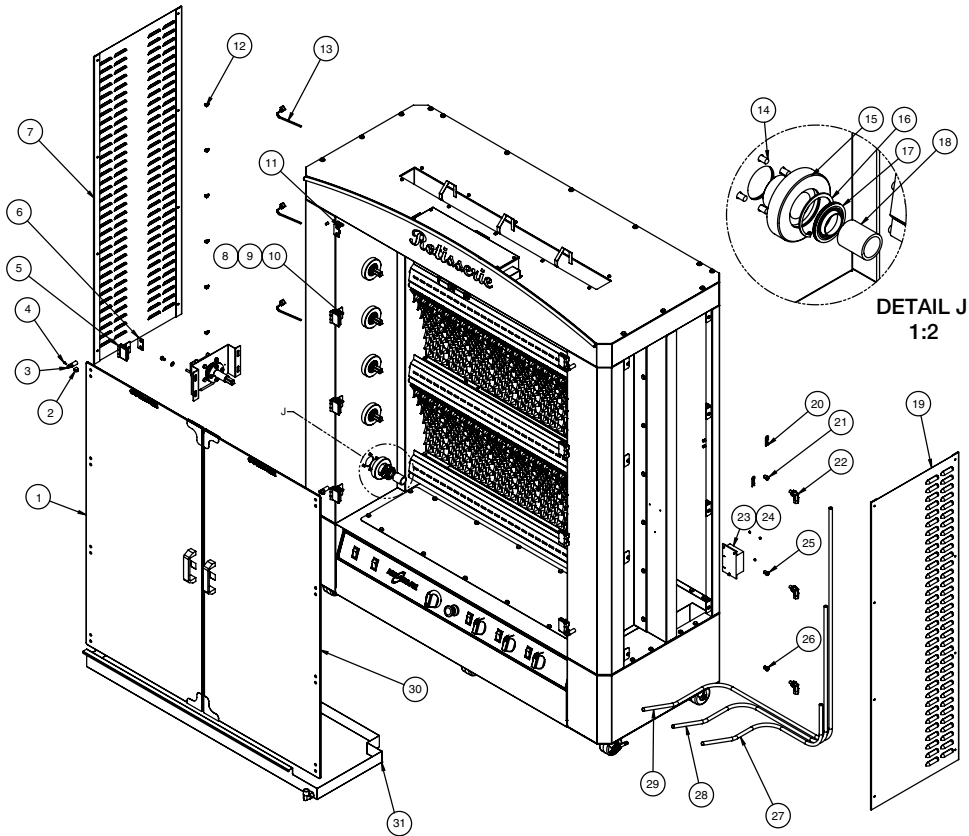

**FINAL FLOOR ASSEMBLY - BACK VIEW**

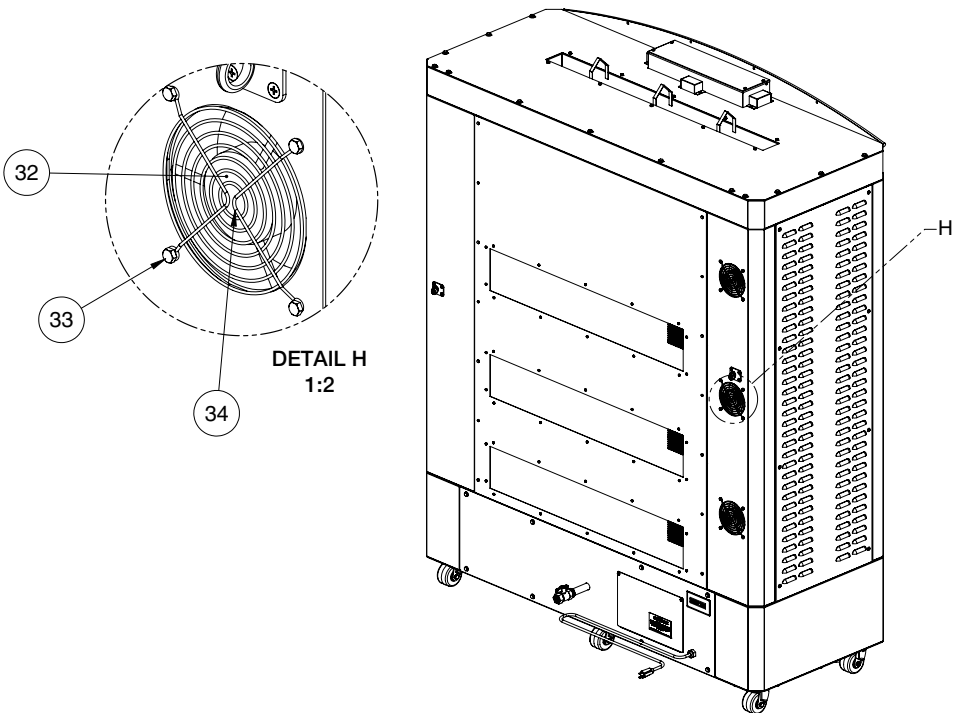

Part numbers and drawings are subject to change without notice.

# SERVICE

## FINAL FLOOR ASSEMBLY - FRONT & BACK VIEW

\* NOT SHOWN

ITEM	PART NO.	DESCRIPTION	QTY	ITEM	PART NO.	DESCRIPTION	QTY
1	5005248	DOOR ASSEMBLY, LEFT	1	31	5005246	DRIP TRAY ASSEMBLY	1
2	GI-27590	DOOR GUIDE, NYLON STOP	4	32	FA-3599	FAN, 115V 131 CFM	3
3	ST-27592	DOOR STOP STUD, BRASS	4	33	SC-26791*	SCREW 10-32 X 1/4" PAN HEAD	6
4	SC-2254	SCREW, 6-32 X 3/8" DOOR STOP MOUNT	7	34	GD-2396	FAN GUARD	3
5	HG-28788	DOOR HINGE	8	35	1006527*	BURNER COVER PLATE	3
6	SP-28134	HINGE SPACER	16	36	1006551*	SPARK IGNITER BRACKET	3
7	1006530	COVER REAR, LEFT (S/S)	1	37	1007535*	LH BRACKET	3
	PE-27601	COVER REAR, LEFT (BLK)	1	38	1007537*	RH BRACKET	3
8	WS-23424	#8 FLAT WASHER	24	39	1007590*	SUPPORT BRACKET	2
9	WS-27045	WASHER, #8, LOCK WASHER	24	40	1007592*	SUPPORT BRACKET	2
10	SC-22730	SCREW 8-32 X 1/2" HEX HEAD S/S	24	41	1007594*	SUPPORT BRACKET	2
11	SC-23664	SCREW M4 X 10MM HEX HEAD TRIM	16	41	5005243*	BURNER COVER SPOT (S/S)	3
12	CL-27628	CLIP WIRE TIE	6		PE-28027*	BURNER COVER SPOT (BLK)	3
13	CD-33338	CORD FOR 4" BOX FAN	3	42	5005513*	MOTOR MOUNT ASSEMBLY	6
14	SC-22729	SCREW 1/4-20 X 1/2" HEX HEAD	76	43	5008157*	MAIN STRUCTURE ASSEMBLY (S/S)	1
15	BU-27579	SPIT BUSHING	6		5005237*	MAIN STRUCTURE ASSEMBLY (BLK)	1
16	CL-27574	O-RING CLIP	6	44	BK-33364*	T-BLOCK MODULAR	4
17	SA-27518	SEAL, SHAFT, ROTARY	6	45	BN-34417*	BURNER	3
18	BG-28033	BEARING	6	46	NU-2215*	NUT,10-32,NF HEX MS,#18-8 S/S	12
19	1006538	COVER REAR, RIGHT (S/S)	1	47	NU-2437*	NUT, 1/4-20 HEX S/S	24
	PE-27606	COVER REAR, RIGHT (BLK)	1	48	RA-27583*	CAST RAIL	6
20	CL-23979	CLEVIS CLIP	12	49	SC-2459*	8-32 X 1/4" PHIL SCREW	6
21	OR-28127	ORIFICE NAT #1 (NATURAL GAS)	1	50	SC-2472*	SCREW,6-32 X1/2, NC PHIL TRUSS M/S,18-8	8
	OR-28130	ORIFICE NAT #38 (PROPANE GAS)	1	51	SC-2661*	SCREW,10-32 X1/2, NF PHIL TRUSS M/S,18-8	28
22	FT-26394	FITTING, ELBOW	3	52	SC-28434*	SCREW, 10-32 X 3/8" HEX HD	12
23	CC-34411	SPARK CONTROL	1	53	SN-34520*	FLAME BENT SENSOR	3
24	NU-2361	NUT, 6-32 HEX, S/S	3	54	5014752*	SERVICE KIT, IGNITION, WIRE, TOP	1
25	OR-28128	ORIFICE NAT #20 (NATURAL GAS)	1	55	5014753*	SERVICE KIT, IGNITION, WIRE, MIDDLE	1
	OR-28191	ORIFICE NAT #41 (PROPANE GAS)	1	56	5014754*	SERVICE KIT, IGNITION, WIRE, BOTTOM	1
26	OR-28129	ORIFICE NAT #29 (NATURAL GAS)	1	57	ST-27595*	BURNER STUD	12
	OR-28132	ORIFICE NAT #43 (PROPANE GAS)	1	58	TL-27515*	TILE CAST	24
27	1009652	BOTTOM BURNER TUBING	1	59	TL-27629*	CAST END TILE	3
28	1009653	MIDDLE BURNER TUBING	1	60	WS-22094*	WASHER, 1/4", FLAT, 5/8 OD 18-8 SS	48
29	1009654	TOP BURNER TUBING	1	61	WS-23671*	WASHER, LOCK, #10, 18-8 S/S	6
30	5005247	DOOR ASSEMBLY, RIGHT	1	62	WS-23672*	WASHER, FLAT, #10, 18-8 S/S	12

Part numbers and drawings are subject to change without notice.

## MOTOR MOUNT ASSEMBLY

### Notes:

- Must use arbor press or vise clamp press to fit motor shaft to motor (see drawing for spacing).
- Use Locktite on screws #6 & #10.

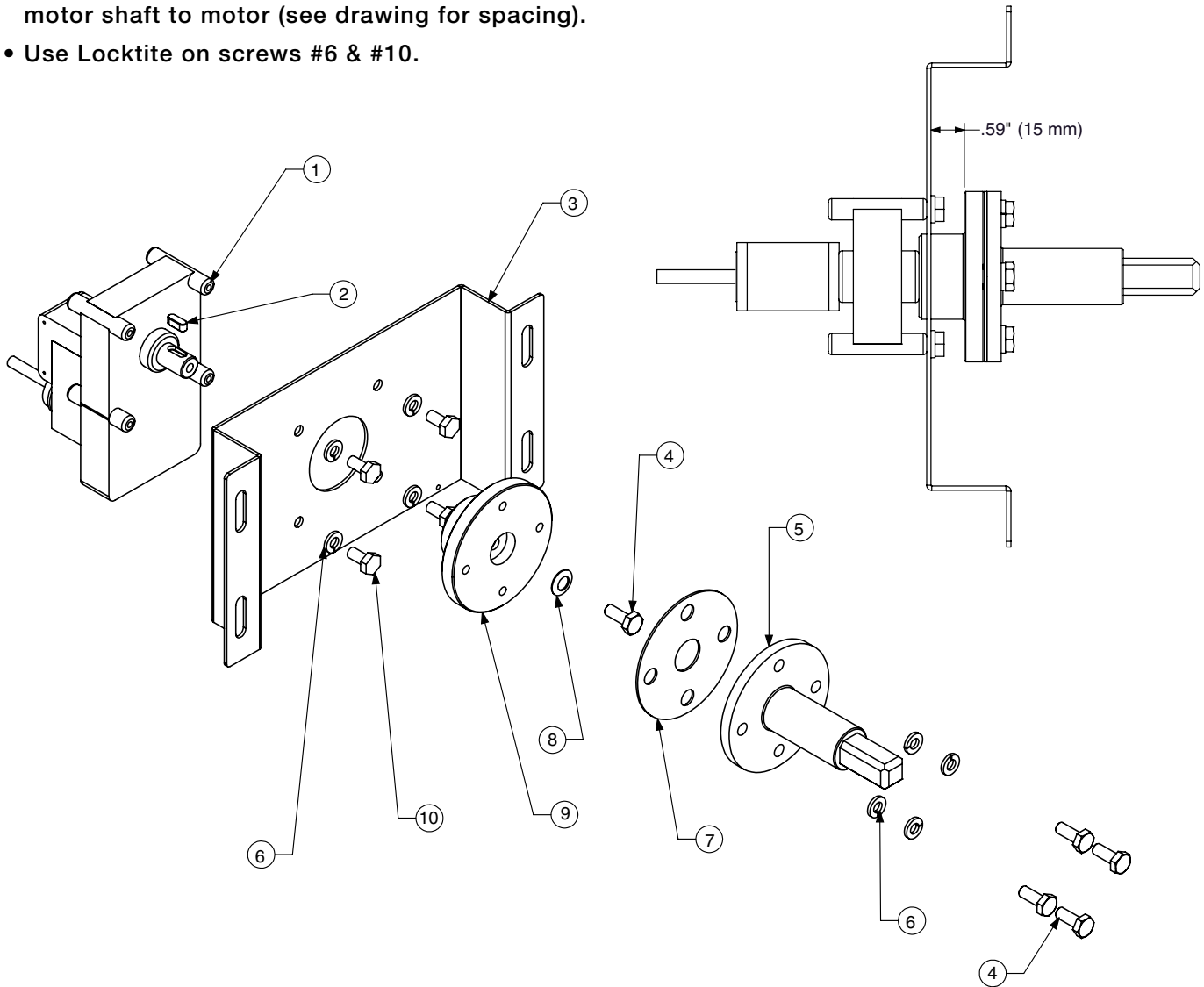

ITEM	PART NO.	DESCRIPTION	QTY	ITEM	PART NO.	DESCRIPTION	QTY
1	<a href="#">MO-34412</a>	MOTOR	1	6	<a href="#">WS-2294</a>	LOCK WASHER 1/4"	8
2	<a href="#">DV-27620</a>	KEY 3/16" SQ X 0.5"	1	7	<a href="#">1010023</a>	MOTOR SPACER	1
3	<a href="#">1006817</a>	MOTOR MOUNT BRACKET	1	8	<a href="#">WS-24396</a>	WASHER M8 S/S SERRATED BEVEL	1
4	<a href="#">SC-27385</a>	SCREW 1/4-20 X 3/4" LG HEX HEAD	5	9	<a href="#">CR-27580</a>	MOTOR SHAFT CONNECTOR	1
5	<a href="#">SI-27589</a>	SPIT, COUPLING	1	10	<a href="#">SC-22729</a>	SCREW 1/4-20 X 1/2" HEX HEAD	4

Part numbers and drawings are subject to change without notice.

# SERVICE

## TOP ASSEMBLY

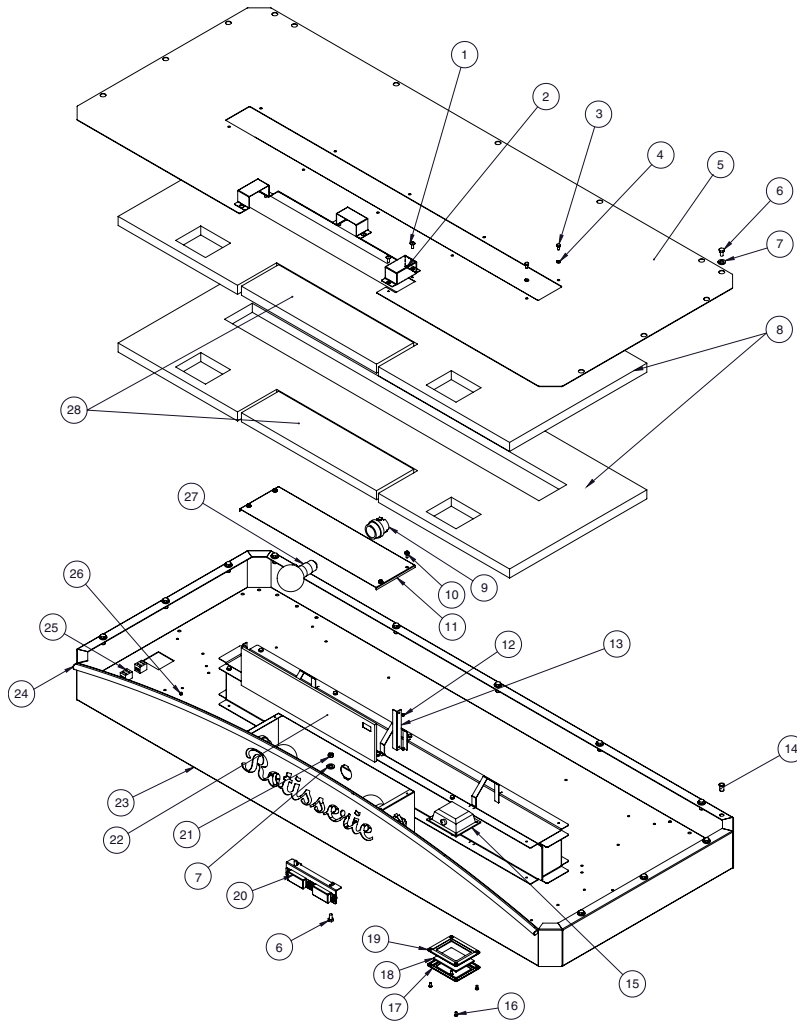

ITEM	PART NO.	DESCRIPTION	QTY	ITEM	PART NO.	DESCRIPTION	QTY
1	<a href="#">SC-2661</a>	SCREW,10-32 X1/2,NF PHIL TRUSS M/S,18-8	6	16	SC-2660	8-32 X 3/8" PHIL FLAT SCREW	12
2	1006552	RECEPTACLE COVER	3	17	<a href="#">CV-26607</a>	COVER FOR OVEN LIGHT	3
3	SC-28434	SCREW, 10-32 X 3/8" HEX HD	10	18	<a href="#">GL-26608</a>	GLASS, OVEN LIGHT	1
4	<a href="#">WS-22301</a>	WASHER, M5 SPLIT LOCK 18-8	10	19	<a href="#">GS-26609</a>	GASKET, OVEN LIGHT	2
5	1006546	TOP COVER	1	20	5005516	MAGNET ASSEMBLY	3
6	<a href="#">SC-22729</a>	SCREW 1/4-20 X 1/2" HEX HEAD	25	21	<a href="#">NU-2437</a>	NUT, 1/4-20 HEX S/S	2
7	<a href="#">WS-22096</a>	3/8" LOCK WASHER, 18-8	15	22	GL-27575	GLASS, LAMP	3
8	<a href="#">IN-24588</a>	INSULATION, 1" THICK CER. WOOL	2	23	5005255	TOP ASSEMBLY SPOT / WELD (S/S)	1
9	<a href="#">RP-3952</a>	LAMP RECEPTACLE, 120V, USA	3		PE-27604	TOP ASSEMBLY SPOT / WELD (BLK)	1
10	<a href="#">SC-26520</a>	SCREW, #10 X 1/2 SMS HEX HEAD SLOTTED	4	24	TU-27511	BRASS TUBE SCHEDULE 40	1
11	1007526	LAMP BOX COVER	1	25	<a href="#">BK-33546</a>	BLOCK, 2 TERMINAL, PORCELAIN	2
12	<a href="#">RI-2100</a>	RIVET,BLIND,#44,STNLS	4	26	<a href="#">RI-2097</a>	#42 STAINLESS RIVET	6
13	1006540	TOP GLASS BRACKET	2	27	<a href="#">LP-33598</a>	LAMP, A19 STYLE, 60W 120V	3
14	<a href="#">NU-24613</a>	1/4-20 INSERT NUT	13	28	<a href="#">IN-24588</a>	INSULATION, 1" THICK CER. WOOL	2
15	<a href="#">LP-34185</a>	LAMP ASSEMBLY 20W	3				
	<a href="#">LP-34213</a>	REPLACEMENT BULB	1				

Part numbers and drawings are subject to change without notice.

## GAS PLUMBING ASSEMBLY

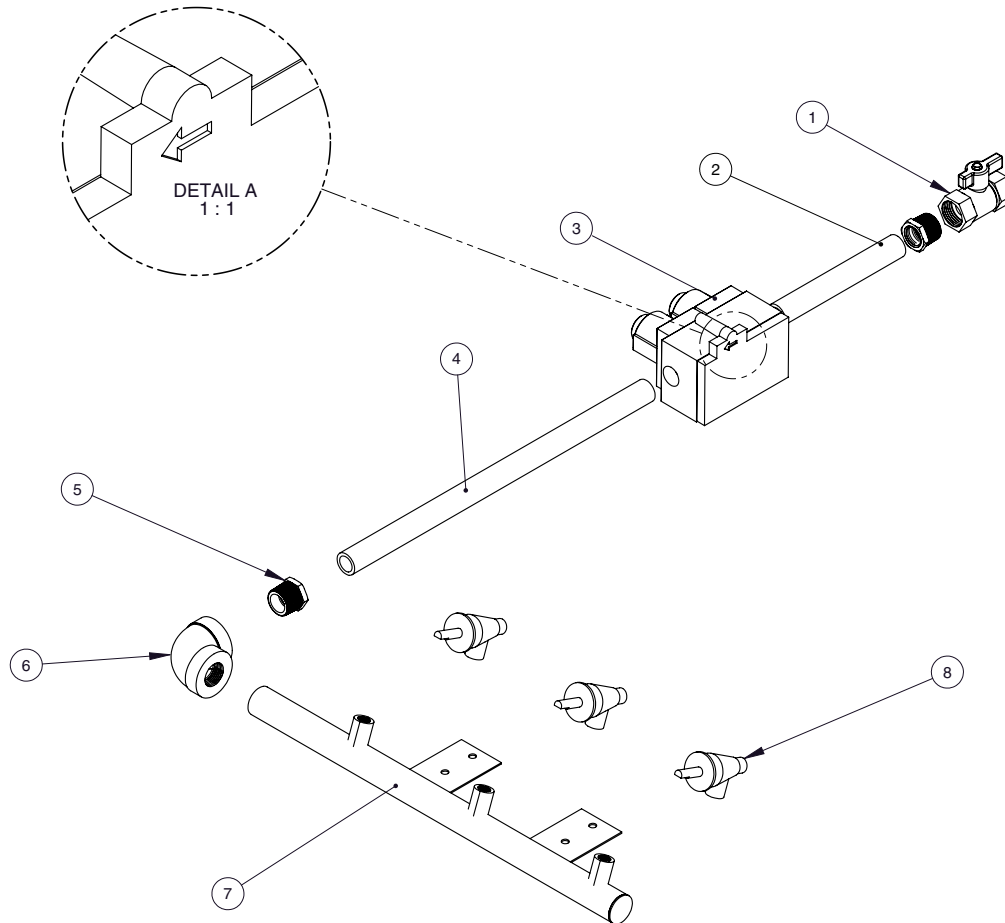

ITEM	PART NO.	DESCRIPTION	QTY
1	VA-25527	VALVE, 3/4" NPT GAS	1
2	PP-29563	PIPE, 1/2" NPT X 6" TBE	1
3	VA-27519	COMBINATION GAS VALVE	1
4	PP-29562	PIPE, 1/2" NPT X 15" TBE	1
5	BU-26460	BUSHING	2
6	EB-25543	3/4" FEMALE X 3/4" FEMALE	1
7	PP-27593	PIPE WELD ASSEMBLY	1
8	VA-27516	GAS BURNER VALVE L-H/OFF	3
9	VA-28444*	VALVE CONVERSION KIT (PROPANE ONLY)	1

\* NOT SHOWN

Part numbers and drawings are subject to change without notice.

# SERVICE

## BOTTOM ASSEMBLY

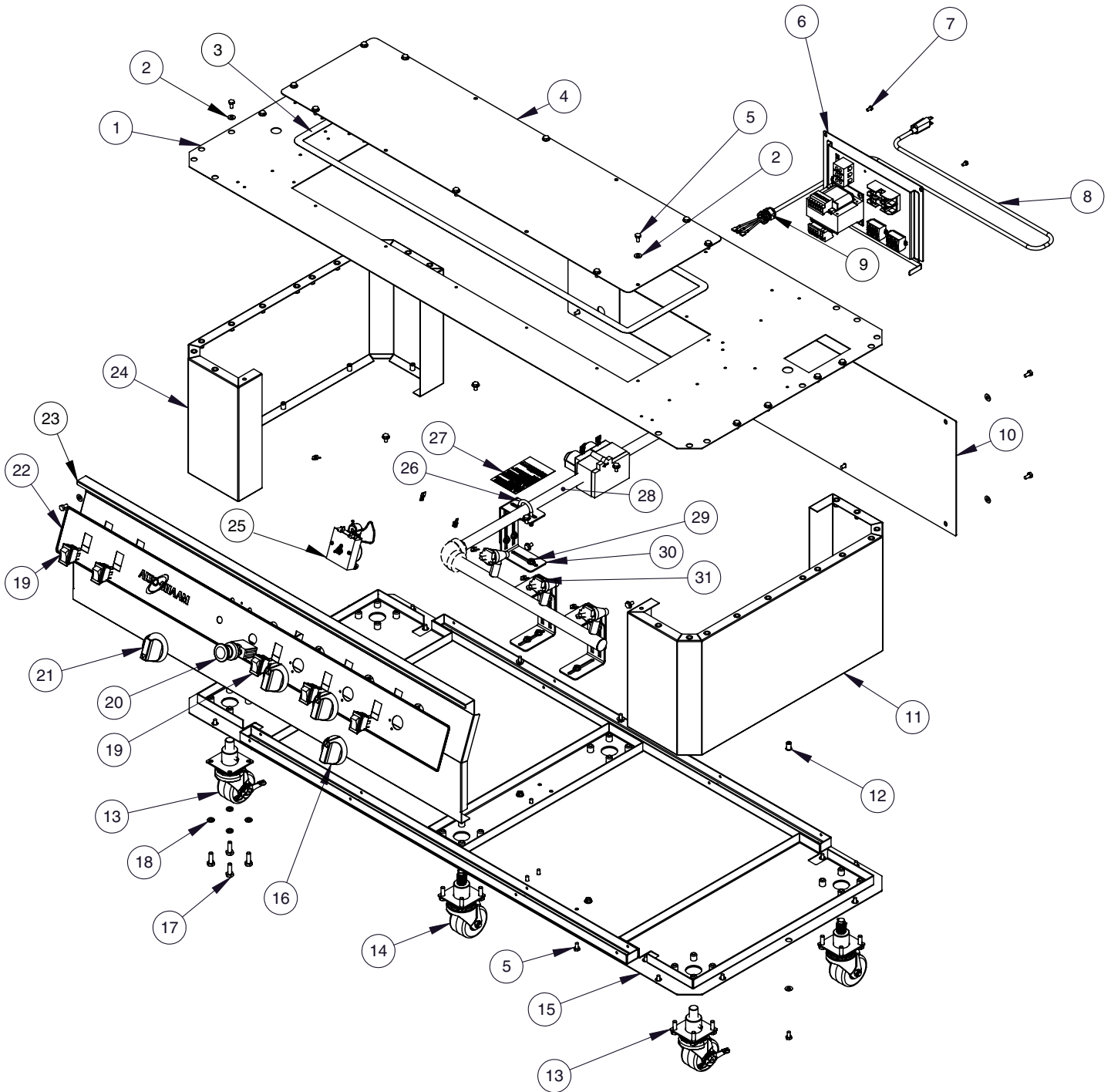

Part numbers and drawings are subject to change without notice.

## BOTTOM ASSEMBLY

\* NOT SHOWN

ITEM	PART NO.	DESCRIPTION	QTY	ITEM	PART NO.	DESCRIPTION	QTY
1	5005242	BOTTOM TOP PLATE SPOT	1	23	5012971	LOWER FRONT PANEL SPOT (S/S)	1
2	<a href="#">WS-22094</a>	WASHER, 1/4", FLAT, 5/8 OD 18-8 SS	67		PE-29429	LOWER FRONT PANEL SPOT (BLK)	1
3	<a href="#">TA-28540</a>	TAPE HIGH TEMP GASKET, 9' (2743mm)	1	24	1006508	BOTTOM SIDE PANEL, LEFT (S/S)	1
4	1006515	BOTTOM ACCESS COVER	1		PE-27609	BOTTOM SIDE PANEL, LEFT (BLK)	1
5	<a href="#">SC-22729</a>	SCREW 1/4-20 X 1/2" HEX HEAD	74	25	<a href="#">TR-34725</a>	2 HOUR TIMER W/ BUZZER	1
6	5009176	ELECTRICAL PANEL	1		PE-36696	TIMER, OVERLAY SERVICE KIT (FOR UNITS PRIOR TO 1/2014, CONTACT SERVICE WITH SERIAL #)	1
7	SC-28434	SCREW 10-32 X 3/8" HEX HEAD	2	26	HR-27630	HANGER, U BOLT	1
8	<a href="#">CD-34094</a>	CORD 16/3 SJT, NEMA 5-15P, 10' (3048mm)	1	27	LA-34435	LABEL, FUSE WARNING	1
9	<a href="#">BU-3964</a>	BUSHING, STRAIGHT, STRAIN RELIEF	1	28	5005252	GAS PLUMBING ASSEMBLY	1
10	1006511	BOTTOM COVER BACK COVER	1	29	<a href="#">NU-2437</a>	NUT, 1/4-20 HEX S/S	19
11	1006509	BOTTOM SIDE PANEL, RIGHT (S/S)	1	30	1008936	SUPPORT BRACKET	6
	PE-27610	BOTTOM SIDE PANEL, RIGHT (BLK)	1	31	SW-34985	SWITCH, SPARK	3
12	<a href="#">NU-24613</a>	1/4-20 INSERT NUT	38		<a href="#">5012978*</a>	SPARK SWITCH SERVICE KIT (FOR UNITS PRIOR TO 2011, CONTACT SERVICE WITH SERIAL #)	1
13	<a href="#">5008607</a>	CASTER WELD WITH LH BRAKE	2	32	NU-2296*	NUT, HEX #8-32	6
14	<a href="#">5008609</a>	CASTER WELD WITH NO BRAKE	4	33	SC-24751*	SCREW 8-32 X 1/4" HEX HEAD	6
15	5005239	BOTTOM PLATE SPOT & WELD	1	34	CR-33250*	CONNECTOR, 3/16" DUAL SPADE	1
16	<a href="#">KN-28061</a>	KNOB, GAS SHUTOFF	3	35	CR-34559*	CONNECTOR	2
17	<a href="#">SC-2191</a>	SCREW, HEX HEAD, 5/16-18 X 1" LONG	24	36	CR-3849*	CONNECTOR, DUAL SPADE, 1/4"	5
18	WS-2867	WASHER, LOCK, 5/16 DIA.	24	37	<a href="#">BK-33364*</a>	T-BLOCK, MODULAR	2
19	<a href="#">SW-34101</a>	SWITCH, FAN HI/LOW	5	38	<a href="#">FU-3772*</a>	FUSE HOLDER, DUAL, 15A, CLASS G	1
20	<a href="#">SW-34430</a>	SWITCH, EMERGENCY STOP	1	39	<a href="#">FU-3775*</a>	15A CLASS G FUSE	2
21	<a href="#">KN-34858</a>	KNOB, INDICATOR	1	40	<a href="#">TN-33460*</a>	TRANSFORMER, STEP DOWN	1
22	PE-36695	PANEL OVERLAY AR-6G	1	41	<a href="#">BK-3019*</a>	T-BLOCK	1
				42	<a href="#">5007975*</a>	WIRE SET 120V	1

Part numbers and drawings are subject to change without notice.

# SERVICE

## BULB REPLACEMENT INSTRUCTIONS

### TO REPLACE CAVITY BULBS:

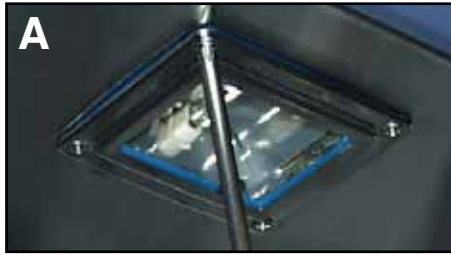

**A** Remove the four screws (**SC-2352**) holding the glass light cover (**CL-26608**) and gasket (**GS-26609**) in place, taking care to not let the glass cover fall into the oven.



**B** Pull bulb out  
**C** Push replacement bulb (**LP-34213**) in place



**D** Re-install glass cover and gasket, securing with four screws removed in step A.

## CAUTION



The performance of this unit has been optimized using the factory provided bulbs. These bulbs should be replaced with an exact replacement or with a factory recommended replacement. These bulbs have been treated to resist breakage and must be replaced with similarly treated bulbs in order to maintain compliance with NSF standards. **DO NOT** over-tighten bulbs in their receptacles as this can cause damage to the bulb filament.

## CAUTION



**DO NOT HANDLE NEW BULB WITH BARE HANDS. WHITE COTTON GLOVES SHOULD BE WORN WHEN REPLACING BULBS.**

### TO REPLACE SIGNAGE BULBS:

- A** Remove the four screws (**a: SC-28434**) holding the lamp box cover (**b: 1007526**)
- B** Unscrew bulb (**c: LP-33598**) to be replaced
- C** Install replacement bulb (**c**)
- D** Resecure lamp box cover (**b**) with the four screws (**a**) removed in step A.

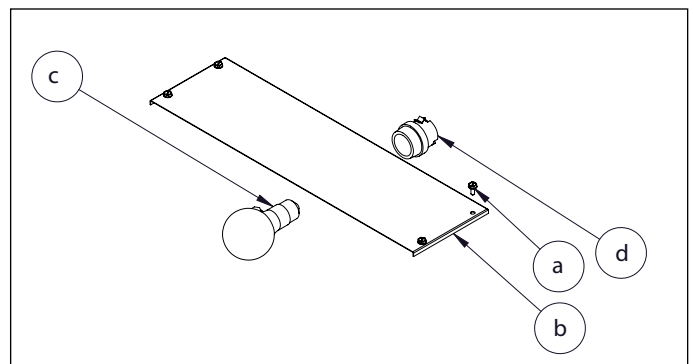

REFER TO PAGE 26 FOR THE FULL VIEW OF THE TOP ASSEMBLY AND PART NUMBERS.

Part numbers and drawings are subject to change without notice.

Use this list as a final check of appliance installation conformance. Damage directly attributed to improper set up, installation, or cleaning can invalidate warranty claims.

## CLEARANCES:

All clearances must conform with the standards set by Alto-Shaam as indicated in the installation manual. Standards include a minimum 20" (50cm) clearance from any heat-producing device such as an open burner range, flat top grille, fryer, steamer, etc. Also make sure sufficient service access is provided on the left side of the appliance. There must be an allowance of free air access to all vents. Verify that appliance is installed on a non-combustible floor and it must be located under a ventilation hood.

RIGHT SIDE CLEARANCE: \_\_\_\_\_

LEFT SIDE CLEARANCE: \_\_\_\_\_

REAR CLEARANCE: \_\_\_\_\_

UPPER CLEARANCE: \_\_\_\_\_

## GAS CONNECTIONS:

Verify that gas connections are 3/4" NPT pipe or 3/4" commercial flexible gas connector. Verify incoming gas pressure is at least 7" WC for natural gas and 11" WC for propane. Verify that gas valve outlet pressure is 5" WC for natural gas and 10" WC for propane. Verify that if a commercial flexible gas connector is used that it is not run under the appliance, but connected at the rear of the appliance.

NATURAL GAS  PROPANE

GAS CONNECTION: \_\_\_\_\_

INCOMING GAS PRESSURE: \_\_\_\_\_

GAS OUTLET PRESSURE: \_\_\_\_\_

CONNECTION AT REAR OF APPLIANCE: \_\_\_\_\_

## PHYSICAL CONDITION:

- Bottom of appliance has been checked for damage due to improper positioning on site. ....
- Verify the installation of drip trays .....
- Verify the appliance is level and installed on a solid, water resistant floor .....

SERVICE AGENCY: \_\_\_\_\_

START-UP DATE: \_\_\_\_\_

INSTALLATION NAME: \_\_\_\_\_

TECH SIGNATURE: \_\_\_\_\_

CUSTOMER SIGNATURE: \_\_\_\_\_

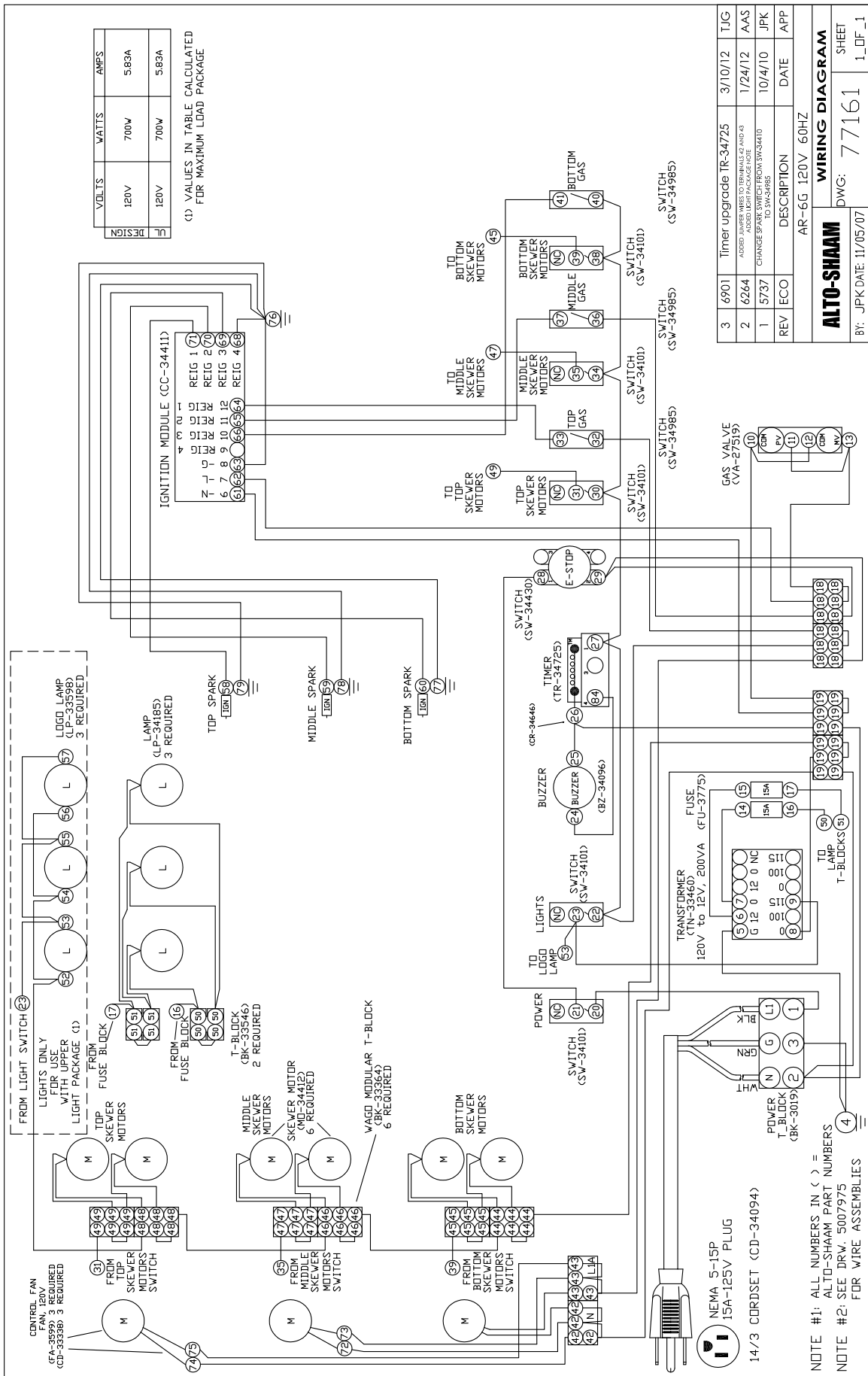

# TRANSPORTATION DAMAGE and CLAIMS



All Alto-Shaam equipment is sold F.O.B. shipping point, and when accepted by the carrier, such shipments become the property of the consignee.

Should damage occur in shipment, it is a matter between the carrier and the consignee. In such cases, the carrier is assumed to be responsible for the safe delivery of the merchandise, unless negligence can be established on the part of the shipper.

1. Make an immediate inspection while the equipment is still in the truck or immediately after it is moved to the receiving area. Do not wait until after the material is moved to a storage area.
2. Do not sign a delivery receipt or a freight bill until you have made a proper count and inspection of all merchandise received.
3. Note all damage to packages directly on the carrier's delivery receipt.
4. Make certain the driver signs this receipt. If he refuses to sign, make a notation of this refusal on the receipt.
5. If the driver refuses to allow inspection, write the following on the delivery receipt:  
*Driver refuses to allow inspection of containers for visible damage.*
6. Telephone the carrier's office immediately upon finding damage, and request an inspection. Mail a written confirmation of the time, date, and the person called.
7. Save any packages and packing material for further inspection by the carrier.
8. Promptly file a written claim with the carrier and attach copies of all supporting paperwork.

We will continue our policy of assisting our customers in collecting claims which have been properly filed and actively pursued. We cannot, however, file any damage claims for you, assume the responsibility of any claims, or accept deductions in payment for such claims.

## LIMITED WARRANTY

Alto-Shaam, Inc. warrants to the original purchaser only that any original part that is found to be defective in material or workmanship will, at Alto-Shaam's option, subject to provisions hereinafter stated, be replaced with a new or rebuilt part.

### The original parts warranty period is as follows:

For the refrigeration compressor on Alto-Shaam Quickchillers™, five (5) years from the date of installation of appliance.

For the heating element on Halo Heat® cooking and holding ovens, as long as the original purchaser owns the oven. This excludes holding only equipment.

For all other original parts, one (1) year from the date of installation of appliance or fifteen (15) months from the shipping date, whichever occurs first.

The labor warranty period is one (1) year from the date of installation or fifteen (15) months from the shipping date, whichever occurs first.

Alto-Shaam will bear normal labor charges performed during standard business hours, excluding overtime, holiday rates or any additional fees.

To be valid, a warranty claim must be asserted during the applicable warranty period. This warranty is not transferable.

### THIS WARRANTY DOES NOT APPLY TO:

1. Calibration.
2. Replacement of light bulbs, door gaskets, and/or the replacement of glass due to damage of any kind.
3. Equipment damage caused by accident, shipping, improper installation or alteration.
4. Equipment used under conditions of abuse, misuse, carelessness or abnormal conditions, including but not limited to, equipment subjected to harsh or inappropriate chemicals, including but not limited to, compounds containing chloride or quaternary salts, poor water quality, or equipment with missing or altered serial numbers.
5. Damage incurred as a direct result of poor water quality, inadequate maintenance of steam generators and/or surfaces affected by water quality. Water quality and required maintenance of steam generating equipment is the responsibility of the owner/operator.
6. Damage caused by use of any cleaning agent other than Alto-Shaam's Combitherm® Cleaner, including but not limited to damage due to chlorine or other harmful chemicals. **Use of Alto-Shaam's Combitherm® Cleaner on Combitherm® ovens is highly recommended.**
7. Any losses or damage resulting from malfunction, including loss of product, food product, revenue, or consequential or incidental damages of any kind.
8. Equipment modified in any manner from original model, substitution of parts other than factory authorized parts, removal of any parts including legs, or addition of any parts.

This warranty is exclusive and is in lieu of all other warranties, express or implied, including the implied warranties of merchantability and fitness for a particular purpose. In no event shall Alto-Shaam be liable for loss of use, loss of revenue or profit, or loss of product, or for any indirect, special, incidental, or consequential damages. No person except an officer of Alto-Shaam, Inc. is authorized to modify this warranty or to incur on behalf of Alto-Shaam any other obligation or liability in connection with Alto-Shaam equipment.



Effective November 1, 2012

RECORD THE MODEL AND SERIAL NUMBER OF THE APPLIANCE FOR EASY REFERENCE.

ALWAYS REFER TO BOTH MODEL AND SERIAL NUMBER IN ANY CONTACT WITH ALTO-SHAAM REGARDING THIS APPLIANCE.

Model: \_\_\_\_\_ Date Installed: \_\_\_\_\_  
Voltage: \_\_\_\_\_ Purchased From: \_\_\_\_\_  
Serial Number: \_\_\_\_\_

W164 N9221 Water Street • P.O. Box 450 • Menomonee Falls, Wisconsin 53052-0450 • U.S.A.  
PHONE: 262.251.3800 • 800.558-8744 USA/CANADA FAX: 262.251.7067 • 800.329.8744 U.S.A. ONLY

www.alto-shaam.com

PRINTED IN U.S.A.