



700-RW

**Models:**  
**700-RW**  
**1100-RW**



1100-RW

Pans not included

- **Installation**
- **Operation**
- **Maintenance**

W164 N9221 Water Street • P.O. Box 450  
Menomonee Falls, Wisconsin 53052-0450 U.S.A.

PHONE: 262.251.3800 • 800.558.8744 U.S.A. / CANADA  
FAX: 262.251.7067 • 800.329.8744 U.S.A. ONLY  
[www.alto-shaam.com](http://www.alto-shaam.com)



Consult instructions  
for operation and use.



Warranty and Service Information . . . . .	3
Delivery . . . . .	4
Transportation and Damage Claims . . . . .	5
Unpacking . . . . .	6
Safety Procedures . . . . .	7
Installation . . . . .	9
Dimensions . . . . .	10
Electrical Connections . . . . .	13
Operating Instructions . . . . .	14
General Holding Guidelines . . . . .	15
Cleaning and Preventative Maintenance . . . . .	16
Food Safety . . . . .	18
Service . . . . .	19
Wiring Diagrams - Always refer to the wire diagram(s) included with the appliance for most current version.	
Limited Warranty . . . . .	back cover

## Enjoy your Alto-Shaam Round Well!

---

**Halo Heat®**

Better food quality. Individual well control. Inside Alto-Shaam drop-in food wells, gentle Halo Heat® surrounds each well with precisely controlled, even heat. Water-less design offers safety and less maintenance. Drop-in wells easily fit into any buffet service counter, prep station, or chef's table.

## Extend Your Manufacturer's Warranty

---

**Register**

Registering your appliance ensures prompt service in the event of a warranty claim. You will also receive direct notifications of software updates and additional product information.

Your personal information will not be shared with any other company.

[www.alto-shaam.com/warranty](http://www.alto-shaam.com/warranty)

## Alto-Shaam 24/7 Emergency Repair Service

---

**Call**

Call 800-558-8744 to reach our 24-hour emergency service call center for immediate access to local authorized service agencies outside standard business hours. The emergency service access is provided exclusively for Alto-Shaam equipment and is available throughout the United States through Alto-Shaam's toll free number.

**Availability**

Emergency service access is available seven days a week, including holidays.

This Alto-Shaam appliance has been thoroughly tested and inspected to ensure only the highest quality appliance is provided. Upon receipt, check for any possible shipping damage and report it at once to the delivering carrier. See Transportation Damage and Claims section located in this manual.

This appliance, including unattached items and accessories, may be delivered in one or more packages. Ensure all standard items and options have been received with each appliance as ordered. Save all the information packed with the appliance. Register the appliance online at [www.alto-shaam.com/en/support/warranty-registration](http://www.alto-shaam.com/en/support/warranty-registration) to ensure prompt service in the event of a warranty parts and labor claim.

This manual must be read and understood by all people using or installing the appliance. Contact the Alto-Shaam Tech Team Service Department if you have any questions concerning installation, operation, or maintenance.

1-800-558-8744; servicedept@alto-shaam.com

### The serial number is required for all inquiries.

Always include both model and serial number(s) in any correspondence regarding the appliance.

**Model:** \_\_\_\_\_

**Serial number:** \_\_\_\_\_

**Purchased from:** \_\_\_\_\_

**Date installed:** \_\_\_\_\_ **Voltage:** \_\_\_\_\_



## CAUTION



Appliance and accessories may be heavy. To prevent serious injury, **always** use a sufficient number of trained and experienced workers when moving or leveling appliance and handling accessories.

## Environmental Conditions

### Operational Environmental Conditions

- Before use, appliance must acclimate to room temperature in the environment it is placed – 24 hours is recommended.
- Ambient temperature range of 60°F to 110°F (16°C to 43°C).
- Relative humidity of less than 95% non-condensation.
- Atmospheric pressure range of 50kPa to 106kPa.



All Alto-Shaam equipment is sold Free on Board (F.O.B.) shipping point, and when accepted by the carrier, such shipments become the property of the consignee.

Should damage occur in shipment, do not put the appliance into service until the damage has been inspected by an authorized Alto-Shaam service provider.

Shipping damages are a matter between the carrier and the consignee. In such cases, the carrier is assumed to be responsible for the safe delivery of the merchandise, unless negligence can be established on the part of the shipper.

1. Make an immediate inspection while the appliance is still in the truck or immediately after it is moved to the receiving area. Do not wait until after the appliance is moved to a storage area.
2. Do not sign a delivery receipt or a freight bill until a proper count has been made and inspection of all appliances are received.

3. Note all damage to packages directly on the carrier's delivery receipt.
4. Make certain the driver signs the delivery receipt. If the driver refuses to sign, make a notation of this refusal on the receipt.
5. If the driver refuses to allow inspection, write the following on the delivery receipt: **Driver refuses to allow inspection of containers for visible damage.**
6. Contact the carrier's office immediately upon finding damage, and request an inspection. Mail a written confirmation to the carrier's office with the time, date, and the person called.
7. Save any packages and packing material for further inspection by the carrier.
8. Promptly file a written claim with the carrier and attach copies of all supporting paperwork.

Alto-Shaam will continue our policy of assisting our customers in collecting claims which have been properly filed and actively pursued. Alto-Shaam cannot, however, file any damage claims, assume the responsibility of any claims, or accept deductions in payment for such claims.

Record the model and serial number of the appliance for easy reference. Always refer to both model and serial number in any contact with Alto-Shaam regarding this appliance.

Model: \_\_\_\_\_

Serial Number: \_\_\_\_\_

Date Installed: \_\_\_\_\_

Voltage: \_\_\_\_\_

Purchased From: \_\_\_\_\_

\_\_\_\_\_  
 \_\_\_\_\_  
 \_\_\_\_\_



**Alto-Shaam has established a twenty-four hour emergency service call center to offer immediate customer access to a local authorized service agency outside of standard business hours. The emergency service access is provided exclusively for Alto-Shaam equipment and is available throughout the United States through the use of Alto-Shaam's toll-free number. Emergency service access is available seven days a week including holidays.**

# Unpacking

- Carefully remove the appliance from the carton or crate.

**NOTE:** Do not discard the carton and other packaging material until you have inspected the appliance for hidden damage and tested it for proper operation.

Do not discard this manual. This manual is considered to be part of the appliance and is to be provided to the owner or manager of the business or to the person responsible for training operators. Additional manuals are available from the manufacturer.

- Read all instructions in this manual carefully before installing this appliance, using the appliance or performing routine maintenance. Following procedures other than those indicated in this guide to use and clean the appliance is considered inappropriate and may cause damage, injury or fatal accidents, in addition to voiding the warranty and relieving Alto-Shaam of all liability.
- Remove all protective plastic film, packaging materials, and accessories from the appliance before connecting electrical power. Store any accessories in a convenient place for future use.

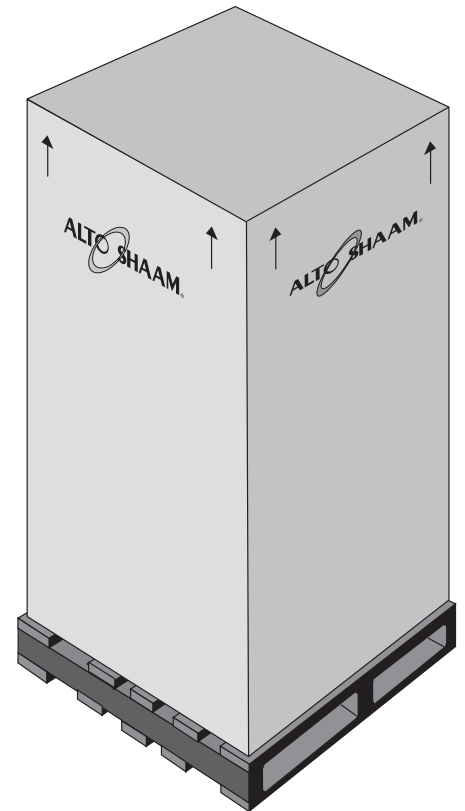

- The appliance is intended to cook, hold or process foods for the purpose of human consumption. No other use for this appliance is authorized and is therefore considered dangerous. The appliance must not be used to cook food containing flammable materials (such as food with alcohol). Substances with a low flash point can ignite spontaneously and cause a fire.
- The appliance is intended for use in commercial establishments where all operators are familiar with the purpose, limitations, and associated hazards of this appliance. Operating instructions and warnings must be read and understood by all operators and users. Alto-Shaam recommends regular staff training to avoid the risk of accident or damage to the appliance. Operators must also receive regular safety instructions.
- Any troubleshooting guides, component views, and parts lists included in this manual are for general reference only and are intended for use by qualified and trained technicians.
- This manual should be considered a permanent part of this appliance. This manual and all supplied instructions, diagrams, schematics, parts lists, notices, and labels must remain with the appliance if the item is sold or moved to another location.

**NOTICE:** For equipment delivered for use in any location regulated by the following directive: 2012/95/EC WEEE



**Do not** dispose of electrical or electronic equipment with other municipal waste.

Knowledge of proper procedures is essential to the safe operation of electrically and/or gas energized equipment. The following signal words and symbols may be used throughout this manual.

**⚠ DANGER**

Indicates a hazardous situation that, if not avoided, will result in death or serious injury.

**⚠ WARNING**

Indicates a hazardous situation that, if not avoided, could result in death or serious injury.

**⚠ CAUTION**

Indicates a hazardous situation that, if not avoided, could result in minor or moderate injury.

**NOTICE:** Indicates information considered important, but not hazard-related (e.g., messages relating to property damage).

 Indicates that referral to operating instructions is recommended to understand operation of equipment.

# Safety Precautions

- To prevent serious injury, death or property damage, the appliance should be inspected and serviced at least every twelve (12) months by an authorized service partner or trained technician.
- **Only** allow an authorized service partner or trained technician to service or to repair the appliance. Installation or repairs that are not performed by an authorized service partner or trained technician, or the use of non-factory authorized parts will void the warranty and relieve Alto-Shaam of all liability.
- When working on this appliance, observe precautions in the literature, on tags, on labels attached to or shipped with the appliance and other safety precautions that may apply.

 **WARNING**

 To prevent **serious personal injury, death, or property damage:**

The appliance must be cleaned thoroughly to avoid deposits of grease and or food residue inside the appliance that may catch fire. If fat deposits and/or food waste inside the appliance ignite, shut down the appliance immediately and keep the appliance door closed to extinguish the fire. If further extinguishing is required, disconnect the appliance from the main power and call the fire department. Failure to clean the appliance properly voids the warranty and relieves Alto-Shaam of all liability.

 **WARNING**

This appliance is not intended for use by persons (including children) with reduced physical, sensory or mental capabilities, or lack of experience and knowledge, unless they have been given supervision concerning use of the appliance by person responsible for their safety.

Children should be supervised to ensure that they do not play with the appliance.

**! WARNING**

Improper installation, alteration, adjustment, service, cleaning, or maintenance could result in property damage, severe injury, or death.

Read and understand the installation, operating and maintenance instructions thoroughly before installing, servicing, or operating this equipment.

**! CAUTION**



Appliance and accessories may be heavy. To prevent serious injury, **always** use a sufficient number of trained and experienced workers when moving or leveling appliance and handling accessories.

**! CAUTION**



To prevent **personal injury** or **property damage**:

**Always** use hand protection when operating this appliance to avoid burns. Metal parts of this equipment become extremely hot when in operation.

**! WARNING**



To prevent personal injury, death or property damage:

**Do not** store or use gasoline or other flammable vapors or liquids in the vicinity of this or any other appliance.

**Site Installation**

The Alto-Shaam round well must be installed in a location that will permit it to function for its intended purpose and to allow adequate clearance for ventilation, proper cleaning, and maintenance access.

1. The round well must be installed on a stable and level surface.
2. **DO NOT** install this round well in any area where it may be affected by any adverse conditions such as steam, grease, dripping water, high temperatures, or any other severely adverse conditions.
3. **DO NOT** store or use any flammable liquids or allow flammable vapors in the vicinity of this round well or any other appliance.
4. This round well must be kept free and clear of any combustible materials.
5. Countertop material must withstand temperature up to 200°F (93°C). Verify countertop material temperature rating with manufacturer before installing to ensure counter can withstand heat.
6. A stainless steel heat shield is recommended if the area under the unit is used for storage.
7. Countertop manufacturer may have specific requirements for installation not covered in this manual. Consult countertop manufacturer for specific installation requirements.
8. Verify required clearance per table below, then make round cutout in countertop in accordance with the drawings on the following pages.
9. Apply a bead of food grade silicone on the top surface of the countertop, around the perimeter of the cutout.
10. Set the round well in the center of the cutout so that the flange is flush with the top of the countertop. Use the supplied clamps to help keep the round well in place. Tighten finger tight only. Wipe away excess silicone after installation.

**LEVELING**

The heated well should be leveled before the electrical supply is connected. Level the well from side-to-side and front-to-back with the use of a spirit level.

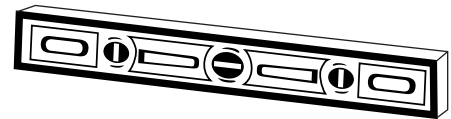

CLEARANCE REQUIREMENTS	
<b>BOTTOM</b>	6" (152mm)
<b>SIDES</b>	6" (152mm)

# Installation

## 700-RW

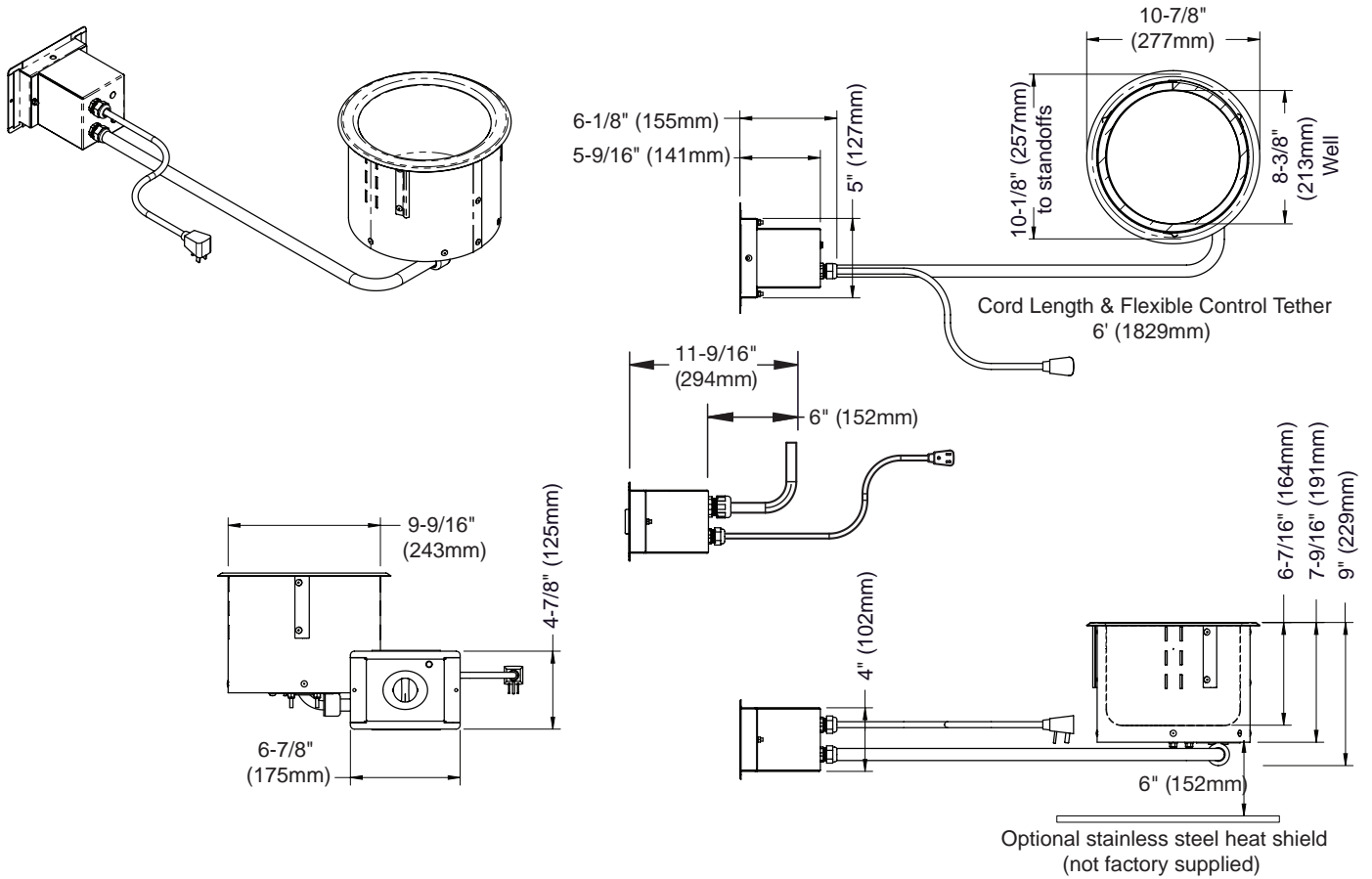

Product Capacity	
Maximum Volume: 7 qt. (6.6 L)	

  

Weight	
<b>Net</b>	10 lbs (5 kg)
<b>Ship</b>	14 lbs (6 kg)

Rough Cut Openings	
Counter Top Cutout	10-1/4" (260mm) Diameter
Control Box Cutout	5-5/16" x 4-1/2" x 11-9/16" (114mm x 133mm x 294mm)

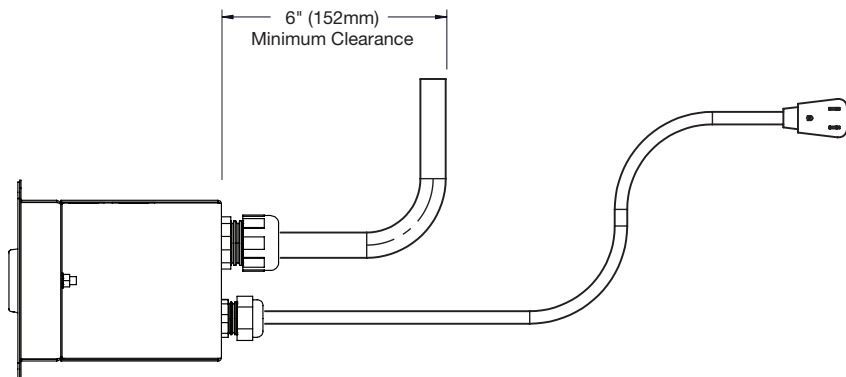

**1100-RW**

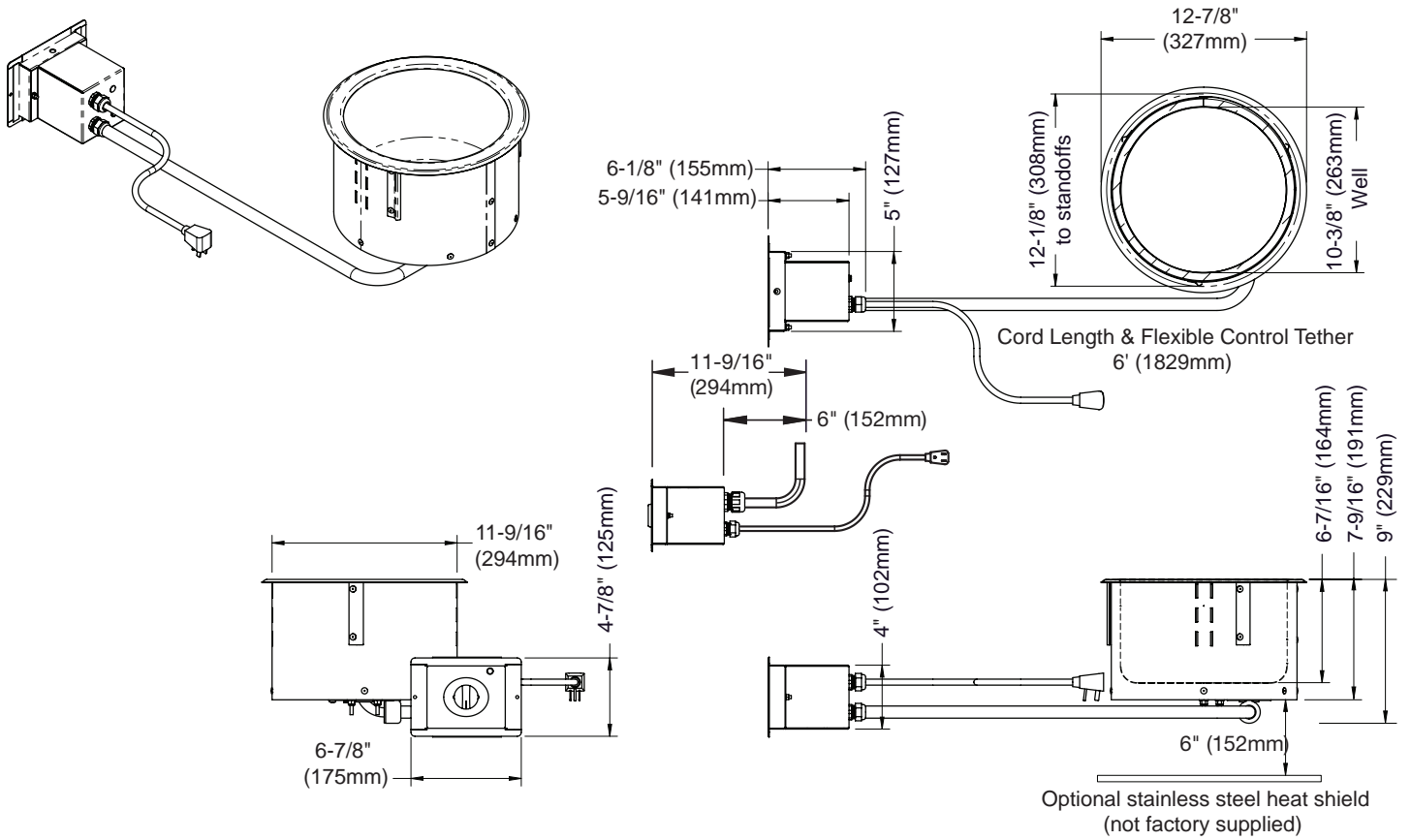

Product Capacity	
Maximum Volume: 11 qt. (10.5 L)	

Weight	
<b>Net</b>	13 lbs (6 kg)
<b>Ship</b>	17 lbs (8 kg)

Rough Cut Openings	
Counter Top Cutout	12-1/4" (311mm) Diameter
Control Box Cutout	5-5/16" x 4-1/2" x 11-1/16" (114mm x 133mm x 294mm)

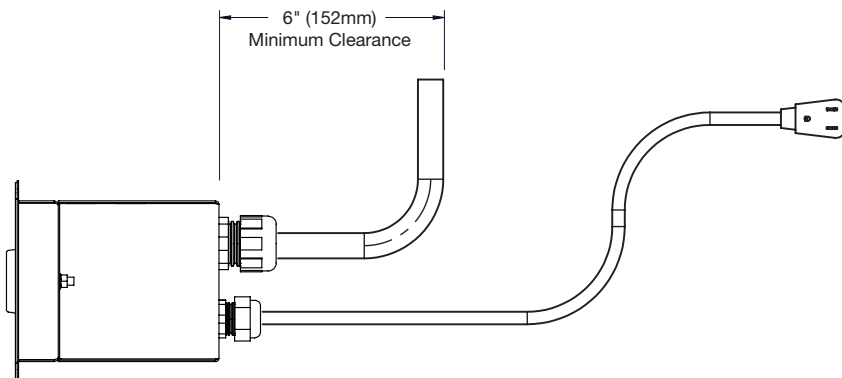

## Remote Control Housing Mounting Instructions

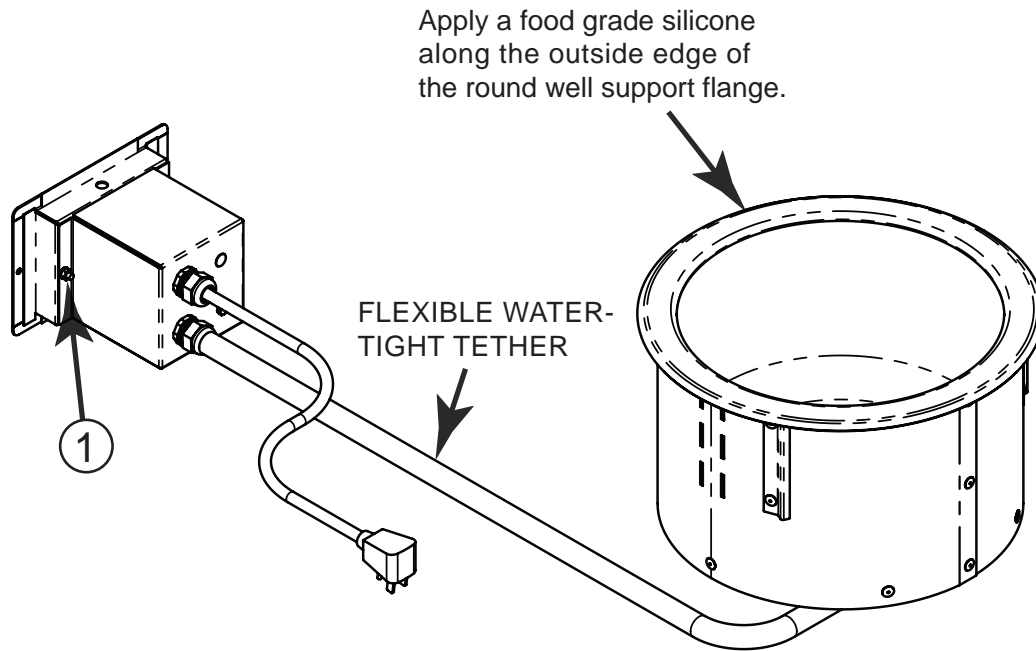

1. Cut a 5-5/16" x 4-1/2" x 11-1/16" (133mm x 114mm x 294mm) opening in the location where the control is to be positioned.
2. Thoroughly clean and dry the mounting surface around the control cut-out opening on which the décor face will be applied.  
**NOTICE:** The control face will not properly adhere to an unclean surface.
3. Remove the décor face from the unit by removing the two nuts **1** from the back of the housing.
4. Making sure "TOP" etching is at the top, route control housing through opening cut in step 1. Secure the décor face housing to the control housing using the nuts removed in step 3.
5. Remove the protective film from the mounting tape on the inside flanges of the décor face and apply the décor face to the mounting surface. Two holes are provided in décor face for additional mounting screws (not provided) if desired.

**⚠ CAUTION**



Power source must match voltage identified on appliance rating tag. The rating tag provides essential technical information required for any appliance installation, maintenance or repairs. Do not remove, damage or modify the rating tag.

**WARNING**



To prevent **SERIOUS INJURY, DEATH** or **PROPERTY DAMAGE**:

All electrical connections must be made by a qualified and trained service technician in accordance with applicable electrical codes.

**⚠ WARNING**



To prevent serious injury, death, or property damage, **always** disconnect the appliance from the power source before cleaning or servicing.

1. An identification tag is permanently mounted on the appliance.
2. This appliance is equipped with a three-prong grounding plug. For your protection against shock hazard this appliance should be plugged directly into a properly grounded three-prong receptacle. Do not cut or remove the grounding prong from this plug. Plug the unit into a properly grounded receptacle **ONLY**, positioning the unit so that the plug is easily accessible in case of an emergency. Arcing will occur when connecting or disconnecting the unit unless all controls are in the "OFF" position.
3. Proper receptacle or outlet configuration or permanent wiring for this unit must be installed by a licensed electrician in accordance with applicable local electrical codes.

**NOTICE:** Where local codes and CE regulatory requirements apply, appliances must be connected to an electrical circuit that is protected by an external GFCI outlet.

**NOTICE:** Round Well must be installed with 15 Amp maximum overcurrent protection or equivalent.

**⚠ WARNING**



To prevent serious injury, death, or property damage:

All electrical connections must be made by a qualified and trained service technician in accordance with applicable electrical codes.







This appliance must be adequately grounded in accordance with local electrical codes or, in the absence of local codes, with the current edition of the National Electrical Code ANSI/NFPA No. 70. In Canada, all electrical connections are to be made in accordance with CSA C22.1, Canadian Electrical Code Part 1 or local codes.







CE-approved appliances include an equipotential-bonding terminal marked with the symbol shown on the left. Provisions for earthing are to be made in accordance with IEC:2010 60335-1 section 27 or local codes.

## 700-RW

Electrical						
V	Ph	Hz	A	kW		Cord & plug
120	1	50/60	3.8	.45		NEMA 5-15P 15A- 125V plug
208-240	1	50/60	1.6-1.9	.34-.45		NEMA 6-15P 15A - 250V plug
230	1	50/60	1.8	.41		Plugs rated 250V
				CEE 7/7		CH2-16P
						BS 1363

## 1100-RW

Electrical						
V	Ph	Hz	A	kW		Cord & plug
120	1	50/60	4.2	.5		NEMA 5-15P 15A- 125V plug
208-240	1	50/60	1.8-2.1	.38-.5		NEMA 6-15P 15A - 250V plug
230	1	50/60	2.0	.46		Plugs rated 250V
				CEE 7/7		CH2-16P
						BS 1363

Other plugs are available. Contact factory for more information.

 **CAUTION**



To prevent **personal injury** or **property damage**:

**Always** use hand protection when operating this appliance to avoid burns. Metal parts of this equipment become extremely hot when in operation.

Before loading food into the round well, use a pocket-type thermometer to make certain all products have reached an internal temperature of 140° to 180°F (60° to 82°C). If any food product is not at proper serving temperature, use a Halo Heat Cook & Hold oven, set at 250° to 275°F (121° to 135°C), or a Combitherm oven to bring the product within the correct temperature range.

### 3. Reset thermostat as needed

After food is loaded into the round well, it is necessary to reset the thermostat. Since proper temperature range depends on the type of products and the quantities being held, it is necessary to periodically use a pocket thermometer to check the food to make certain the correct temperatures are being maintained. Proper temperature range is between a minimum of 140°F and 180°F (60°C and 82°C).

### 4. Serve fresh, hot food

Keep hot foods looking fresh. Occasionally stir or rotate food as needed. Wipe spills immediately to ensure maximum eye appeal and to ease end of day cleanup.

Halo Heat® round wells maintain a constant and gentle temperature. **Adding water is not recommended** since water will accelerate the deterioration of the product and may damage the unit voiding the warranty.

### 1. Preheat the round well

To operate the round well, turn the knob in either direction from 'O' until the pointer is on the desired number setting. To turn off the round well, turn the knob in either direction until the pointer is on 'O'.

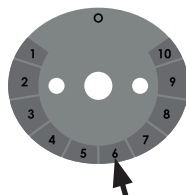

An indicator light will illuminate when the knob is turned to the desired setting. The unit should be preheated at the **6** setting for a minimum of **15 minutes** before loading the unit with hot food pan insert (not included).

### 2. Load hot foods only

After preheating, place hot foods into the pan insert and place the pan insert into the heated well, or exchange the pan insert with a pre-filled pan insert. The round well is designed for the purpose of hot food holding, and only hot food should be placed into the round well. The round well is not designed to cook food, nor is it designed to reheat cold food. Potentially hazardous foods should be held in the round well at setting 10. If lower settings are used, ensure the food has maintained safe food temperatures. Lower settings should be tested by user to ensure food has maintained safe food temperatures between 140°F and 160°F (60°C and 71°C).

Chefs, cooks and other specialized food service personnel employ varied methods of cooking. Proper holding temperatures for a specific food product must be based on the moisture content of the product, product density, volume, and proper serving temperatures. Safe holding temperatures must also be correlated with palatability in determining the length of holding time for a specific product.

Halo Heat maintains the maximum amount of product moisture content without the addition of water, water vapor, or steam. Maintaining maximum natural product moisture preserves the natural flavor of the product and provides a more genuine taste. In addition to product moisture retention, the gentle properties of Halo Heat maintain a consistent temperature throughout the cabinet without the necessity of a heat distribution fan, thereby preventing further moisture loss due to evaporation or dehydration.

When product is removed from a high temperature cooking environment for immediate transfer into equipment with the lower temperature required for hot food holding, condensation can form on the outside of the product and on the inside of plastic containers used in self-service applications. Allowing the product to release the initial steam and heat produced by high temperature cooking can alleviate this condition. To preserve the safety and quality of freshly cooked foods however, a maximum of 1 to 2 minutes must be the only time period allowed for the initial heat to be released from the product.

Most Halo Heat holding equipment is provided with a thermostat control between 60° and 200°F (16° to 93°C). If the unit is equipped with vents, close the vents for moist holding and open the vents for crisp holding.

If the unit is equipped with a thermostat indicating a range of between 1 and 10, use a metal-stemmed indicating thermometer to measure the internal temperature of the product(s) being held. Adjust the thermostat setting to achieve the best overall setting based on internal product temperature.

Holding Temperature Range		
Meat	Fahrenheit	Celsius
Beef Roast — Rare	130°F	54°C
Beef Roast — Med/Well Done	155°F	68°C
Beef Brisket	160°F-175°F	71°C-79°C
Corn Beef	160°F-175°F	71°C-79°C
Pastrami	160°F-175°F	71°C-79°C
Prime Rib — Rare	130°F	54°C
Steaks — Broiled/Fried	140°F-160°F	60°C-71°C
Ribs — Beef Or Pork	160°F	71°C
Veal	160°F-175°F	71°C-79°C
Ham	160°F-175°F	71°C-79°C
Pork	160°F-175°F	71°C-79°C
Lamb	160°F-175°F	71°C-79°C
Poultry		
Chicken — Fried/Baked	160°F-175°F	71°C-79°C
Duck	160°F-175°F	71°C-79°C
Turkey	160°F-175°F	71°C-79°C
General	160°F-175°F	71°C-79°C
Fish/Seafood		
Fish — Baked/Fried	160°F-175°F	71°C-79°C
Lobster	160°F-175°F	71°C-79°C
Shrimp — Fried	160°F-175°F	71°C-79°C
Baked Goods		
Breads/Rolls	120°F-140°F	49°C-60°C
Miscellaneous		
Casseroles	160°F-175°F	71°C-79°C
Dough — Proofing	80°F-100°F	27°C-38°C
Eggs — Fried	150°F-160°F	66°C-71°C
Frozen Entrees	160°F-175°F	71°C-79°C
Hors d'oeuvres	160°F-180°F	71°C-82°C
Pasta	160°F-180°F	71°C-82°C
Pizza	160°F-180°F	71°C-82°C
Potatoes	180°F	82°C
Plated Meals	140°F-165°F	60°C-74°C
Sauces	140°F-200°F	60°C-93°C
Soup	140°F-200°F	60°C-93°C
Vegetables	160°F-175°F	71°C-79°C
The holding temperatures listed are suggested guidelines only. All food holding should be based on internal product temperatures. Always follow local health (hygiene) regulations for all internal temperature requirements.		

## Protecting Stainless Steel Surfaces



It is important to guard against corrosion in the care of stainless steel surfaces. Harsh, corrosive, or inappropriate chemicals can completely destroy the protective surface layer of stainless steel. Abrasive pads, steel wool, or metal implements

will abrade surfaces causing damage to this protective coating and will eventually result in areas of corrosion. Even water, particularly hard water that contains high to moderate concentrations of chloride, will cause oxidation and pitting that result in rust and corrosion. In addition, many acidic foods spilled and left to remain on metal surfaces are contributing factors that will corrode surfaces.

Proper cleaning agents, materials, and methods are vital to maintaining the appearance and life of this appliance. Spilled foods should be removed and the area wiped as soon as possible but at the very least, a minimum of once per day. Always thoroughly rinse surfaces after using a cleaning agent and wipe standing water as quickly as possible after rinsing.

## Cleaning Agents

Use non-abrasive cleaning products designed for use on stainless steel surfaces. Cleaning agents must be chloride-free compounds and must not contain quaternary salts. Never use hydrochloric acid (muriatic acid) on stainless steel surfaces. Failure to observe this precaution will void the warranty. Always use the proper cleaning agent at the manufacturer's recommended strength. Contact your local cleaning supplier for product recommendations.

## Cleaning Materials

Cleaning can usually be accomplished with the proper cleaning agent and a soft, clean cloth. When more aggressive methods are needed, use a non-abrasive scouring pad on difficult areas and make certain to scrub with the visible grain of surface metal to avoid surface scratches. Never use wire brushes, metal scouring pads, or scrapers to remove food residue. Failure to observe this precaution will void the warranty.

### NOTICE



To protect stainless steel surfaces, completely avoid the use of abrasive cleaning compounds, chloride based cleaners, or cleaners containing quaternary salts. **Never** use hydrochloric acid (muriatic acid) on stainless steel. **Never** use wire brushes, metal scouring pads or scrapers.

### WARNING



To prevent **SERIOUS PERSONAL INJURY, DEATH, or PROPERTY DAMAGE:**

If the appliance is not cleaned or is not cleaned well enough, deposits of grease and or food residues inside the appliance may catch fire. If fat deposits and/or food waste inside the appliance ignite disconnect the appliance from the main power and use a fire extinguisher (do not use water to extinguish a grease fire!). Failure to clean the appliance properly may cause fire, personal injury, death, invalidates the warranty and relieves Alto-Shaam of all liability.

## ⚠ WARNING



To prevent serious personal injury, death, or property damage:

**Do not** steam clean, hose down or flood the interior or exterior with water or liquid solution of any kind. **Do not** use water jet to clean. Failure to observe this precaution will void the warranty.

## ⚠ WARNING



To prevent serious injury, death, or property damage, **always** disconnect the appliance from the power source before cleaning or servicing.

### Clean the food well daily

1. Disconnect round well from the power source. Let unit cool.
2. After the round well has cooled, remove pan insert and clean separately.
3. Remove any food scraps.
4. Wipe the interior metal surfaces with a paper towel to remove any remaining food debris.
5. Clean interior with a damp cloth or sponge and any good commercial detergent at the recommended strength.

**Notice:** Never use abrasive cleaning compounds, chloride-based cleaners, or cleaners containing quaternary salts. Never use hydrochloric acid (muriatic acid) on stainless steel.

6. For baked-on food deposits, use a non-caustic and non-toxic commercial oven cleaner appropriate for the interior surface. Follow the product manufacturer's instructions carefully for the use of this product. Any commercial oven cleaner must be approved for use on food contact areas. Remove soil with the use of a plastic scouring pad.

7. Rinse surfaces by wiping with a clean cloth or sponge and clean warm water.
8. Remove excess water with a sponge and wipe dry with a clean cloth or air dry. Leave area open until interior is completely dry. Replace pan insert.
9. Interior can be wiped with a sanitizing solution after cleaning and rinsing. This solution must be approved for use on stainless steel food contact surfaces.

Always follow appropriate state or local health (hygiene) regulations regarding all applicable cleaning and sanitation requirements for food service equipment.

Food flavor and aroma are usually so closely related that it is difficult, if not impossible, to separate them. There is also an important, inseparable relationship between cleanliness and food flavor. Cleanliness, operating efficiency, and appearance of equipment contribute considerably to savory, appetizing foods.

Most food imparts its own particular aroma and many foods also absorb existing odors. Unfortunately, during this absorption there is not a distinction between **good** and **bad** odors. The majority of objectionable flavors and odors troubling food service operations are caused by bacteria growth. Sourness, rancidity, mustiness, stale or other undesirable flavors are usually the result of germ activity.

The easiest way to ensure full, natural food flavor is through comprehensive cleanliness. This means good control of both visible soil (dirt) and invisible soil (germs). A thorough approach to sanitation will provide essential cleanliness. It will ensure an attractive appearance of equipment, along with maximum efficiency and utility. More importantly, a good sanitation program provides one of the key elements in the prevention of food-borne illnesses.

A comprehensive sanitation program should focus on the training of staff in basic sanitation procedures. This includes personal hygiene, proper handling of raw foods, cooking to a safe internal product temperature, and the routine monitoring of internal food temperatures from the time the food is received through the time the food is served.

A controlled holding environment for prepared foods is just one of the important factors involved in the prevention of food-borne illnesses. Temperature monitoring and control during receiving, storage, preparation, and the service of foods are of equal importance.

The most accurate method of measuring safe temperatures of both hot and cold foods is by internal product temperature. A thermometer is an effective tool for this purpose, and should be routinely used on all products that require holding at a specific temperature.

Internal Food Product Temperatures		
<b>Hot Foods</b>		
Danger Zone	40°F to 140°F	4°C to 60°C
Critical Zone	70°F to 120°F	21°C to 49°C
Safe Zone	140°F to 165°F	60°C to 74°C
<b>Cold Foods</b>		
Danger Zone	Above 40°F	Above 4°C
Safe Zone	36°F to 40°F	2°C to 4°C
<b>Frozen Foods</b>		
Danger Zone	Above 32°F	Above 0°C
Critical Zone	0°F to 32°F	-18°C to 0°C
Safe Zone	0°F or Below	-18°C or Below

Hazard Analysis (at) Critical Control Points (HACCP), is a quality control program of operating procedures to assure food integrity, quality, and safety. Taking steps necessary to augment food safety practices is both cost effective and relatively simple. Additional HACCP information is available by contacting:

Center for Food Safety and Applied Nutrition  
 Food and Drug Administration  
 Phone: 1-888-SAFEFOOD  
[www.foodsafety.gov](http://www.foodsafety.gov)

**Round Well**  
(1100-RW shown)

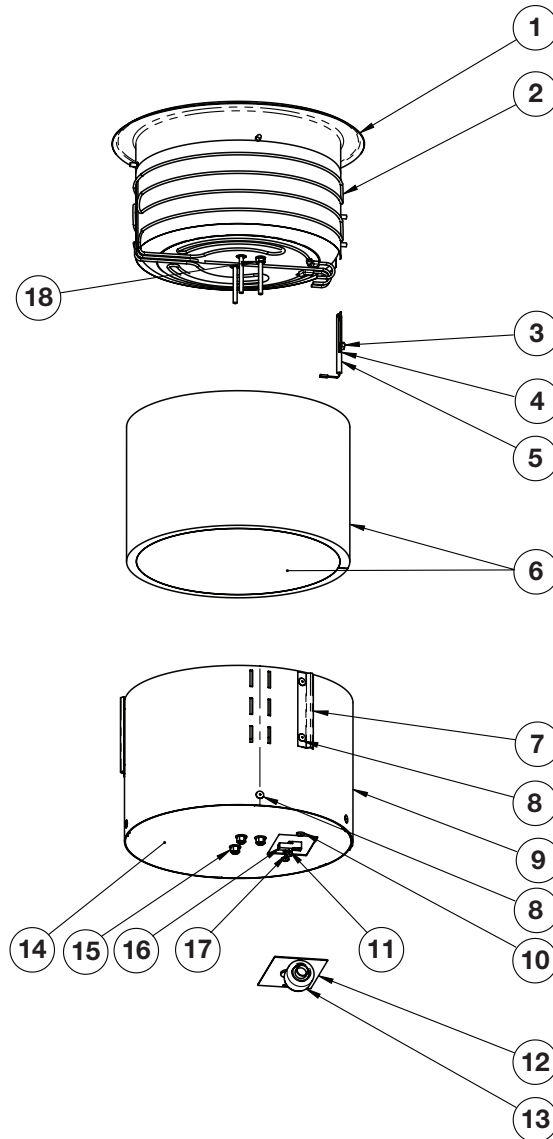

Part numbers and drawings are subject to change without notice.

ITEM	DESCRIPTION	PART NO.	QTY	ITEM	DESCRIPTION	PART NO.	QTY
1	KETTLE ASSEMBLY	700-RW 5016027	1	11	NUT, HEX 5mm WITH STAR WASHER	NU-35851	6
		1100-RW 5016026	1	12	WIRE COVER	1014242	1
2	ELEMENT, FOIL PAD HEATER	700-RW EL-35799	1	13	CONNECTOR FLEX NYLON SWEEP	CR-33179	1
		1100-RW EL-35798	1	14	SHEATH, BOTTOM	700-RW 1014438	1
3	NUT, HEX 5mm WITH STAR WASHER	NU-27851	3			1100-RW 1014207	1
4	CLIP, RTD	1014305	1	15	NUT, FLG, M6 X 1.0, LOCK, NYLON INS	NU-35842	3
5	PROBE, TEMPERATURE	PR-34494	1	16	CONNECTOR, TEMP PROBE, HOUSING	CR-34500	1
6	INSULATION	IN-22364	2	17	SCREW, M5 X 0.8 X 10mm HEX	SC-23737	2
7	STANDOFF BRACKET	1014696	3	18	NUT, KEPS, M6X1.0, S/S	NU-35844	1
8	RIVET, BLIND, #43, LRG FLG, S/S	RI-2094	14	19*	MOUNTING KIT	5016693	1
9	SHEATH, OUTER	700-RW 1014437	1		- MOUNTING BRACKET	1014216	2
		1100-RW 1014206	1		- SCREW, THUMB, 10-32 X 1-1/2", S/S	SC-36056	2
10	SCREW, M5 X 0.8 X 10mm PAN	SC-22766	14	20*	TAPE, ELECTRICAL, INSULATING 2"	TA-3621	7

\*NOT SHOWN

## Electrical Components

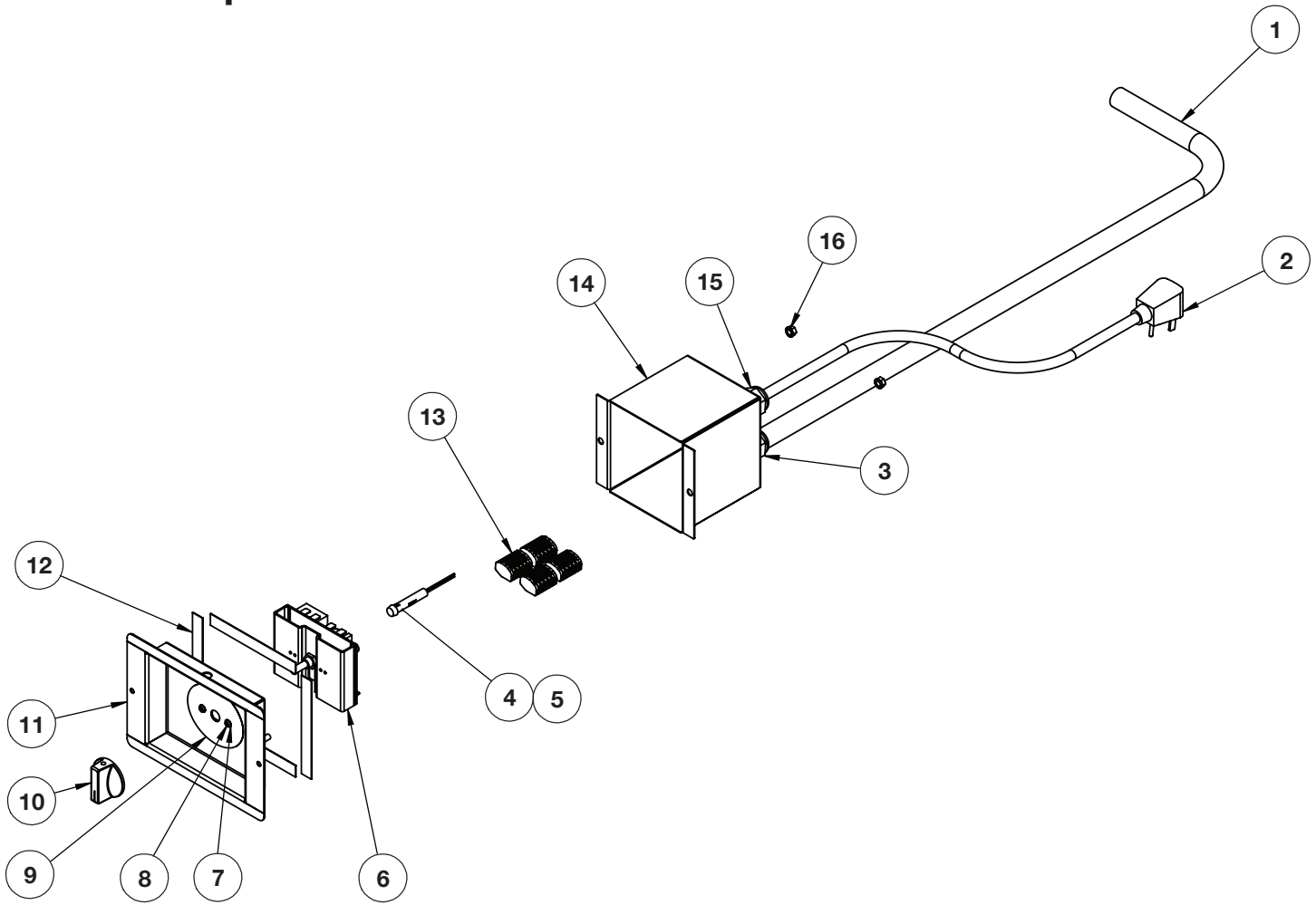

Part numbers and drawings are subject to change without notice.

ITEM	DESCRIPTION	PART NO.	QTY	ITEM	DESCRIPTION	PART NO.	QTY
1	CONDUIT, 6FT (1829mm)	<a href="#">TU-33178</a>	1	6	CONTROL	<a href="#">CC-36441</a>	1
2	CORDSET* 120V (90° PLUG)	<a href="#">CD-3232</a>	1	7	WASHER, #6, LOCK, INT., #410 S/S	<a href="#">WS-2768</a>	2
	120V (STRAIGHT PLUG)	<a href="#">CD-34094</a>	1	8	SCREW, 6-32 X 1/4 PAN HD	<a href="#">SC-22500</a>	2
	208-240V	<a href="#">CD-33840</a>	1	9	PANEL OVERLAY	<a href="#">PE-36566</a>	1
	230V (CEE 7/7)	<a href="#">CD-3922</a>	1	10	KNOB	<a href="#">KN-36424</a>	1
	230V (CH2-16P)	<a href="#">CD-36231</a>	1	11	DECOR FACE ASSEMBLY	5016206	1
	230V (BS-1363)	<a href="#">CD-33925</a>	1	12	TAPE, VHB FOAM, 1/2" X 72 YD	<a href="#">TA-24637</a>	4
3	BUSHING, STRAIGHT, STRAIN RELIEF	<a href="#">BU-34606</a>	1	13	CONNECTOR-5 CONDUCTOR	<a href="#">CR-34646</a>	4
4	INDICATOR LIGHT 120V	<a href="#">LI-35869</a>	1	14	CONTROL POD SHELL ASSEMBLY	5016269	1
	208-240V, 230V	<a href="#">LI-35870</a>	5	15	BUSHING, STRAIGHT, STRAIN RELIEF	<a href="#">BU-3964</a>	1
5	CONNECTOR, TERM, 25" INSULATED	<a href="#">CR-3806</a>	1	16	NUT, HEX 5MM WITH STAR WASHER	<a href="#">NU-27851</a>	2

\*Other plugs are available. Contact factory for more information.

Refer to wire diagram sent with unit for most current version

### 700-RW

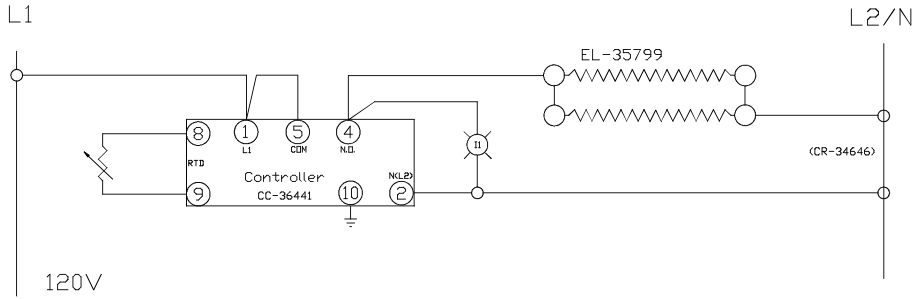

Voltage	Pilot Light	Controller
120V	LI-35869	CC-36441

Voltage	Pilot Light	Controller
208-240V	LI-35870	CC-36441

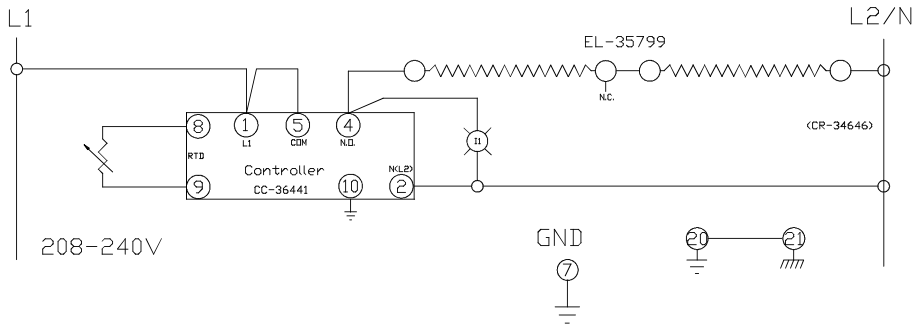

Cordset	Line 1	Line 2/N
120V	Black	White
230V	Brown	Blue
208-240V	Black	White

### 1100-RW

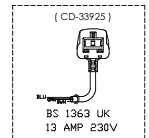
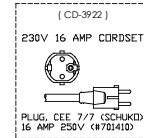
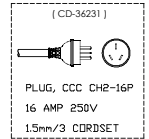
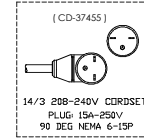
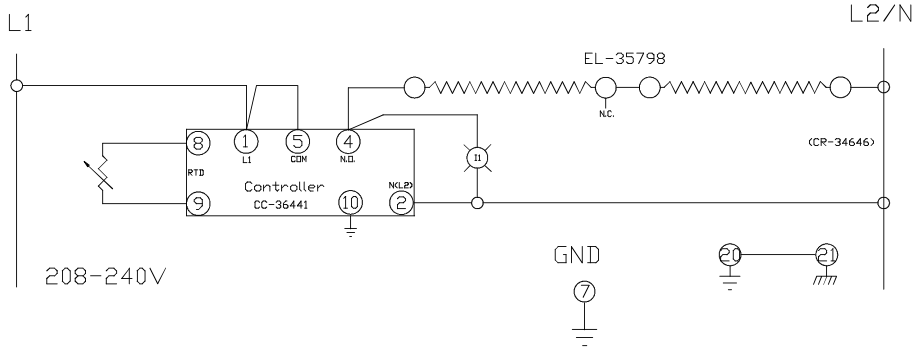
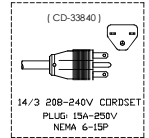
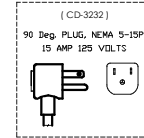
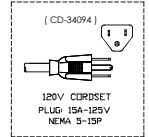
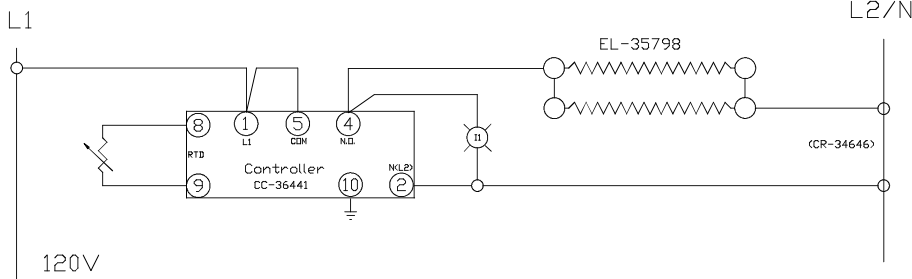

700-RW: FOIL PAD OF HI-TEMP CABLE EL-35799 = 128 OHMS <SERIES>, 32 OHMS <PARALLEL> AMBIENT TEMP  
 1100-RW: FOIL PAD OF HI-TEMP CABLE EL-35798 = 115.2 OHMS <SERIES>, 28.8 OHMS <PARALLEL> AMBIENT TEMP

REFERENCE WIRE ASSBY #5016491

5	7422	Add CD-34094	05/22/2015	TJG
4	7370	Cord Upgrades	03/31/2015	TJG
3	6819	Control Upgrade CC-36441	10/18/2013	TJG
REV	ECO	DESCRIPTION	DATE	APP
700-RW, 1100-RW 120V, 230 V, 208-240VAC 50/60Hz				
<b>ALTO-SHAAM</b>		<b>WIRING DIAGRAM</b>		
BY: JPF DATE: 03/11/13		DWG: 77535		SHEET 1 OF 1

# Limited Warranty



Alto-Shaam, Inc. warrants to the original purchaser only that any original part that is found to be defective in material or workmanship will, at Alto-Shaam's option, subject to provisions hereinafter stated, be replaced with a new or rebuilt part.

## The original parts warranty period is as follows:

For the refrigeration compressor on Alto-Shaam Quickchillers™, five (5) years from the date of installation of appliance.

For the heating element on Halo Heat® cooking and holding ovens, as long as the original purchaser owns the oven. This excludes holding only equipment.

For all other original parts, one (1) year from the date of installation of appliance or fifteen (15) months from the shipping date, whichever occurs first.

The labor warranty period is one (1) year from the date of installation or fifteen (15) months from the shipping date, whichever occurs first.

Alto-Shaam will bear normal labor charges performed during standard business hours, excluding overtime, holiday rates or any additional fees.

To be valid, a warranty claim must be asserted during the applicable warranty period. This warranty is not transferable.

## This warranty does not apply to:

1. Calibration.
2. Replacement of light bulbs, door gaskets, and/or the replacement of glass due to damage of any kind.
3. Equipment damage caused by accident, shipping, improper installation or alteration.
4. Equipment used under conditions of abuse, misuse, carelessness or abnormal conditions, including but not limited to, equipment subjected to harsh or inappropriate chemicals, including but not limited to, compounds containing chloride or quaternary salts, poor water quality, or equipment with missing or altered serial numbers.
5. Damage incurred as a direct result of poor water quality, inadequate maintenance of steam generators and/or surfaces affected by water quality. Water quality and required maintenance of steam generating equipment is the responsibility of the owner/operator.
6. Damage caused by use of any cleaning agent other than Alto-Shaam's Combitherm® Cleaner, including but not limited to damage due to chlorine or other harmful chemicals. **Use of Alto-Shaam's Combitherm® Cleaner on Combitherm® ovens is highly recommended.**
7. Any losses or damage resulting from malfunction, including loss of product, food product, revenue, or consequential or incidental damages of any kind.
8. Equipment modified in any manner from original model, substitution of parts other than factory authorized parts, removal of any parts including legs, or addition of any parts.

This warranty is exclusive and is in lieu of all other warranties, express or implied, including the implied warranties of merchantability and fitness for a particular purpose. In no event shall Alto-Shaam be liable for loss of use, loss of revenue or profit, or loss of product, or for any indirect, special, incidental, or consequential damages. No person except an officer of Alto-Shaam, Inc. is authorized to modify this warranty or to incur on behalf of Alto-Shaam any other obligation or liability in connection with Alto-Shaam equipment.

Effective November 1, 2012

W164 N9221 Water Street • P.O. Box 450  
Menomonee Falls, Wisconsin 53052-0450 U.S.A.

PHONE: 262.251.3800 • 800.558.8744 U.S.A. / CANADA  
FAX: 262.251.7067 • 800.329.8744 U.S.A. ONLY  
[www.alto-shaam.com](http://www.alto-shaam.com)

Printed in the U.S.A