

ALTO SHAAM®

**Hot Food Display
Cabinet, Electric**



**Model:
600-LVD**

- **INSTALLATION**
- **OPERATION**
- **MAINTENANCE**

**HALO
HEAT®**

24•7
Your Service Hotline
1-800-558-8744

W164 N9221 Water Street • P.O. Box 450 • Menomonee Falls, Wisconsin 53052-0450 USA

PHONE: 262.251.3800 • 800.558.8744 USA/CANADA

FAX: 262.251.7067 • 800.329.8744 U.S.A. ONLY

WEBSITE: www.alto-shaam.com

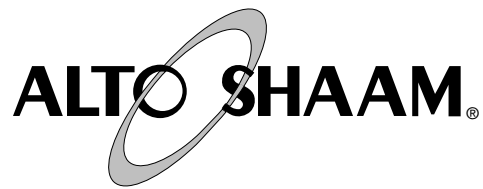

DELIVERY

This Alto-Shaam appliance has been thoroughly tested and inspected to insure only the highest quality unit is provided. Upon receipt, check for any possible shipping damage and report it at once to the delivering carrier. *See Transportation Damage and Claims section located in this manual.*

This appliance, complete with unattached items and accessories, may have been delivered in one or more packages. Check to ensure that all standard items and options have been received with each model as ordered.

Save all the information and instructions packed with the appliance. Complete and return the warranty card to the factory as soon as possible to assure prompt service in the event of a warranty parts and labor claim.

This manual must be read and understood by all people using or installing the equipment model. Contact the Alto-Shaam service department if you have any questions concerning installation, operation, or maintenance.

NOTE: All claims for warranty must include the full model number and serial number of the unit.

UNPACKING

1. Carefully remove the appliance from the carton or crate.

NOTE: Do not discard the carton and other packaging material until you have inspected the unit for hidden damage and tested it for proper operation.

2. Read all instructions in this manual carefully before initiating the installation of this appliance.

DO NOT DISCARD THIS MANUAL.

This manual is considered to be part of the appliance and is to be provided to the owner or manager of the business or to the person responsible for training operators. *Additional manuals are available from the Alto-Shaam service department.*

3. Remove all protective plastic film, packaging materials, and accessories from the appliance before connecting electrical power. Store any accessories in a convenient place for future use.

SAFETY PROCEDURES AND PRECAUTIONS

Knowledge of proper procedures is essential to the safe operation of electrically and/or gas energized equipment. In accordance with generally accepted product safety labeling guidelines for potential hazards, the following signal words and symbols may be used throughout this manual.

DANGER

Used to indicate the presence of a hazard that **will** cause severe personal injury, death, or substantial property damage if the warning included with this symbol is ignored.

WARNING

Used to indicate the presence of a hazard that **can** cause personal injury, possible death, or major property damage if the warning included with this symbol is ignored.

CAUTION

Used to indicate the presence of a hazard that can or will cause minor or moderate personal injury or property damage if the warning included with this symbol is ignored.

CAUTION

Used to indicate the presence of a hazard that can or will cause minor personal injury, property damage, or a potential unsafe practice if the warning included with this symbol is ignored.

NOTE:

Used to notify personnel of installation, operation, or maintenance information that is important but not hazard related.

1. This appliance is intended to cook, hold or process foods for the purpose of human consumption. No other use for this appliance is authorized or recommended.
2. This appliance is intended for use in commercial establishments where all operators are familiar with the purpose, limitations, and associated hazards of this appliance. Operating instructions and warnings must be read and understood by all operators and users.
3. Any troubleshooting guides, component views, and parts lists included in this manual are for general reference only and are intended for use by qualified technical personnel.
4. This manual should be considered a permanent part of this appliance. This manual and all supplied instructions, diagrams, schematics, parts lists, notices, and labels must remain with the appliance if the item is sold or moved to another location.

INSTALLATION

Site Installation

1. This appliance,, complete with unattached items and accessories, may be delivered in one or more packages. Check to insure that all the following items have been received as standard with each unit:

12: Chrome plated wire shelves

2. Alto-Shaam appliances are designed for the purpose of maintaining hot food at a temperature for safe consumption. The unit must be installed on a level surface in a location that will permit the equipment to function for its intended purpose and allow adequate access for proper cleaning and maintenance.

CLEARANCE REQUIREMENTS

3-inches (76mm) at the back

2-inches (51mm) at the top

2-inches (51mm) at both sides

3. The appliance must not be installed in any area where it will be affected by steam, grease, dripping water, high temperatures, or any other severely adverse conditions.

4. Level the appliance from side-to-side and back-to-back with the use of a spirit level.

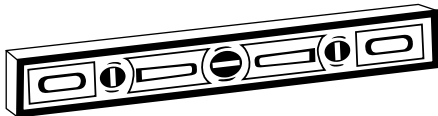

5. In order to maintain standards established by the National Sanitation Foundation, all stationary counter-mounted equipment must be secured flush to the counter and the entire base sealed to the counter with NSF approved sealant or equipped with 4" (102mm) legs to provide minimum unobstructed space beneath the unit. The rubber legs supplied with the unit are 1-1/2" (38mm) high. Warranty will become null and void if these directions are not followed.

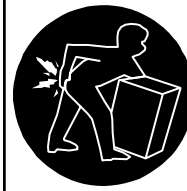

CAUTION

TO PREVENT PERSONAL INJURY,
USE CAUTION WHEN MOVING OR
LEVELING THIS APPLIANCE.

NET WEIGHT

120 lb. (54 kg)



DANGER

IMPROPER INSTALLATION, ALTERATION,
ADJUSTMENT, SERVICE OR MAINTENANCE
COULD RESULT IN SEVERE INJURY, DEATH
OR CAUSE PROPERTY DAMAGE.

INSTALLATION

Site Installation

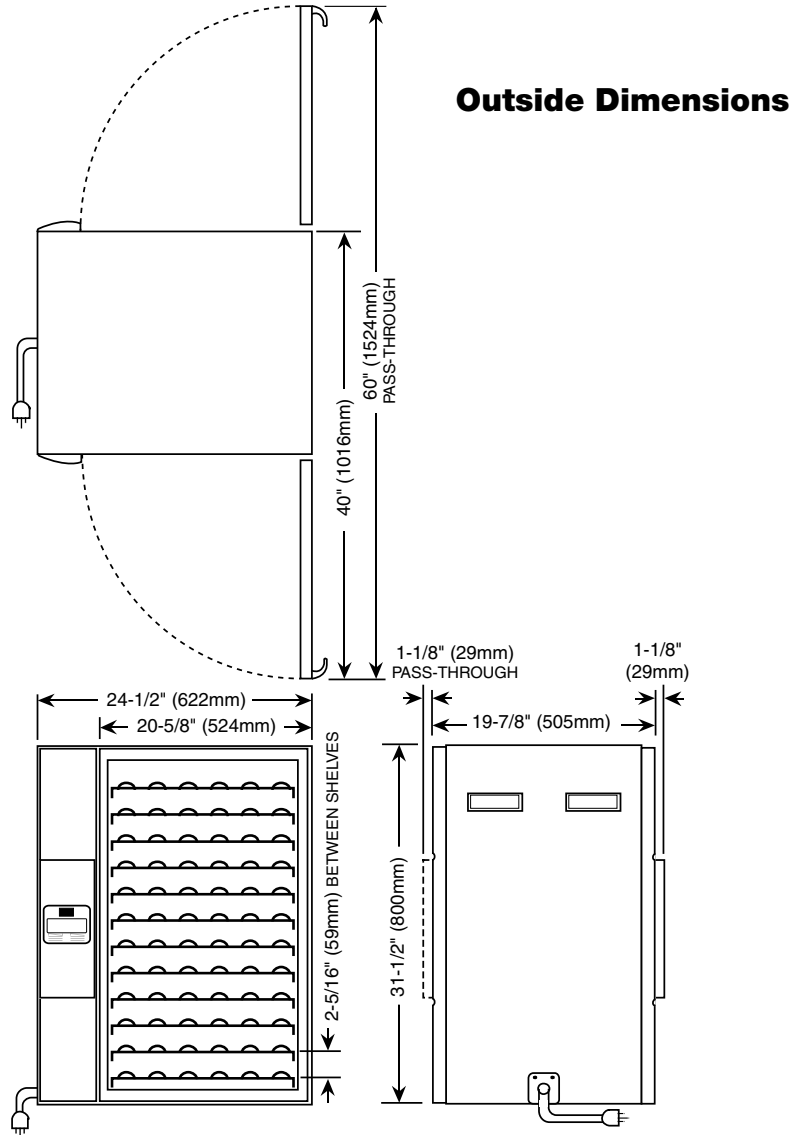

Options and Accessories

Legs, 4" (102mm)	4249
Wire Shelf Reinforcement — TWO REQUIRED FOR EACH SHELF	12210
Shelf, Chrome Plated Wire	SH-22608

INSTALLATION

Electrical Installation

1. An identification tag is permanently mounted on the cabinet.

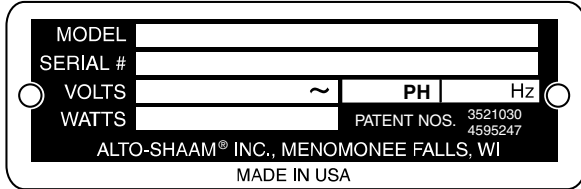

230V:

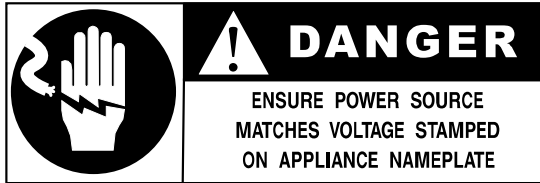

To prevent an electrical shock hazard between the appliance and other appliances or metal parts in close vicinity, an equalization-bonding stud is provided. An equalization bonding lead must be connected to this stud and the other appliances / metal parts to provide sufficient protection against potential difference. The terminal is marked with the following symbol. 

NOTE: The appliance must be connected to an electrical circuit that is protected by an external GFCI outlet.

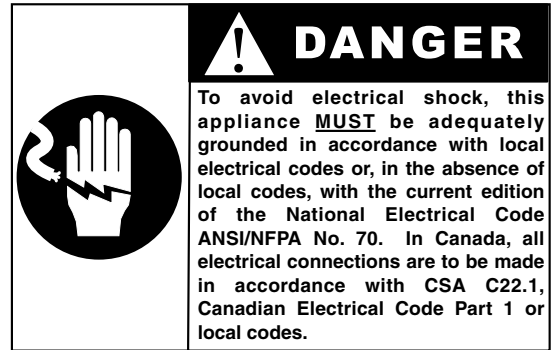

2. Plug the unit into a properly grounded receptacle ONLY. Arcing will occur when connecting or disconnecting the unit unless all controls are in the "OFF" position.
3. Position the unit so the cord is easily accessible in case of any emergencies. If necessary, a proper receptacle or outlet configuration, as required for the unit, must be installed by a licensed electrician in accordance with applicable, local electrical codes.



ELECTRICAL					
VOLTAGE	PHASE	CYCLE/HZ	AMPS	kW	
120	1	60	14.2	1.7	 NEMA 5-20P 20A-125V PLUG
230	1	50/60	9.8	2.3	 CEE 7/7 220-230V PLUG

OPERATION

Thermostat Control Description and Function

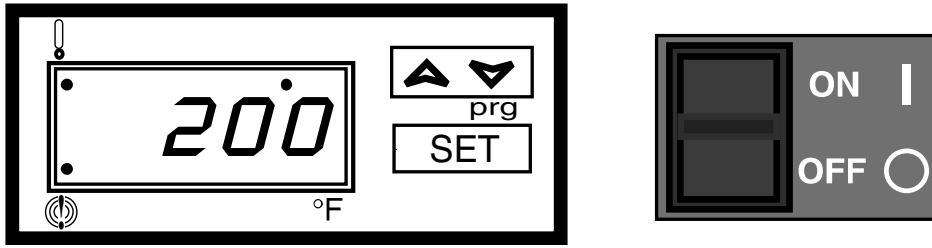

The L.E.D., Light Emitting Diode, referred to is an electronic device providing illumination. The control has a three-digit L.E.D. display. When the warming cabinet is in operation, the L.E.D. will show the chamber's internal temperature. The display will also show programming and diagnostic information.

ON/OFF Rocker Switch

The Power On/Off Rocker Switch positions may be marked with the international "I" for On and "O" for Off.

UP/DOWN Arrow Rocker Button

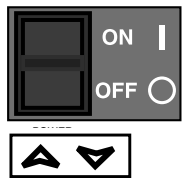

The up/down arrow rocker button is used to increase or decrease the set-point temperature. The minimum set-point temperature is 90°F (32°C) while the maximum set-point temperature is 200°F (93°C).

SET Button

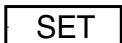

The SET button is used to display the current set-point temperature or program a new set-point temperature. Pushing the SET button once will display the set-point temperature value for five seconds. Holding the SET button allows the programming mode to become active.

L.E.D. Display

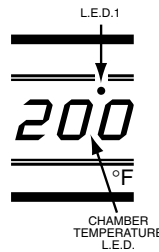

The L.E.D. display will show the set-point temperature value when programming, or the warming chamber's temperature when calling for heat. When programming a new set-point temperature, the L.E.D.1 indicator will blink. When a new set-point temperature is chosen, the Chamber Temperature L.E.D. will flash three times to confirm.

HEAT INDICATOR L.E.D.

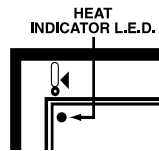

The Heat Indicator L.E.D. will illuminate and remain lit while the unit is calling for heat. It will go out when the air temperature inside the warming chamber reaches the set-point temperature on the control.

OPERATION

User Safety Information

This appliance is intended for use in commercial establishments by qualified personnel who are familiar with the purpose, limitations, and associated hazards of this appliance. Operating instructions and warnings must be read and understood by all operators and users.

BEFORE INITIAL USE:

Clean the metal surface exterior and interior of the appliance with a clean, damp cloth and mild soap solution. Rinse carefully. Clean glass with glass cleaner. Clean and install the cabinet wire shelves.

TURN POWER ON

Press the "ON" or "I" position of the rocker switch to turn on control.



CHANGE SET-POINT TEMPERATURE

Press and hold the SET button for at least 3 seconds. After L.E.D.1 indicator blinks, release the Set Button. The control is now in the programming mode. Press and hold the UP or DOWN arrow rocker button to change the value shown in the display. Store the value by pressing the SET button.



The new set-point value will flash three times to confirm.



HEAT INDICATOR L.E.D.

The Heat Indicator L.E.D. will illuminate as the warming chamber calls for heat. It will extinguish when the warming chamber's interior temperature reaches the set-point.

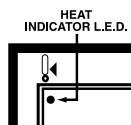

- ❖ Use hand protection when handling hot items.
- ❖ Be certain only hot foods are placed into the cabinet.
- ❖ To avoid personal injury and damage to the unit, treat glass with care. Remember — glass can shatter.



CAPACITY

Twelve 16" (406mm) pizzas MAXIMUM
MAXIMUM WEIGHT EACH PIZZA: 2 lbs. (.9 kg)

PREHEATING THE UNIT

Always preheat the unit at 200°F (93°C) for 30 minutes before loading the merchandiser with hot food.

LOADING THE CABINET

Load the merchandiser with hot food only. The purpose of this unit is to maintain hot food at proper serving temperature. Use a food thermometer to make certain all food has reached an internal temperature range of 140° to 160°F (60° to 71°C). Do not fill cabinet closer than 2" from the sensor. Make certain door is securely closed after loading. Reset the control to 160°F (71°C). THIS WILL NOT NECESSARILY BE THE FINAL SETTING. Proper temperature range for the food being held will depend on the type and quantity of product. It is advisable to periodically check the internal temperature of each item to assure maintenance of proper food serving temperature.

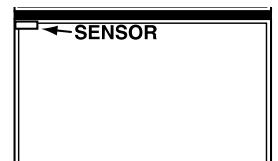

HEATING CHARACTERISTICS

The unit is equipped with a special, low-heat-density, heating cable. Through the Halo Heat concept, the heating cable is mounted against the top surface of the shelf to provide an evenly applied heat source, controlled by a thermostat. Through even heat application, the quality of a food product is maintained up to several hours.

OPERATION

General Holding Guidelines

Chefs, cooks and other specialized food service personnel employ varied methods of cooking. Proper holding temperatures for a specific food product must be based on the moisture content of the product, product density, volume, and proper serving temperatures. Safe holding temperatures must also be correlated with palatability in determining the length of holding time for a specific product.

Halo Heat maintains the maximum amount of product moisture content without the addition of water, water vapor, or steam. Maintaining maximum natural product moisture preserves the natural flavor of the product and provides a more genuine taste. In addition to product moisture retention, the gentle properties of Halo Heat maintain a consistent temperature throughout the cabinet without the necessity of a heat distribution fan, thereby preventing further moisture loss due to evaporation or dehydration.

When product is removed from a high temperature cooking environment for immediate transfer into equipment with the lower temperature required for hot food holding, condensation can form on the outside of the product and on the inside of plastic containers used in self-service applications. Allowing the product to release the initial steam and heat produced by high temperature cooking can alleviate this condition. To preserve the safety and quality of freshly cooked foods however, a maximum of 1 to 2 minutes must be the only time period allowed for the initial heat to be released from the product.

This unit is equipped with a thermostat control between 60° and 200°F (16° and 93°C). If the unit is equipped with vents, close the vents for moist holding and open the vents for crisp holding. Use a metal-stemmed thermometer to measure the internal temperature of the product being held. Adjust the thermostat setting to achieve the best overall setting based on internal product temperature.

HOLDING TEMPERATURE RANGE		
	FAHRENHEIT	CELSIUS
MEAT		
BEEF ROAST — Rare	140°F	60°C
BEEF ROAST — Med/Well Done	160°F	71°C
BEEF BRISKET	160° — 175°F	71° — 79°C
CORN BEEF	160° — 175°F	71° — 79°C
PASTRAMI	160° — 175°F	71° — 79°C
PRIME RIB — Rare	140°F	60°C
STEAKS — Broiled/Fried	140° — 160°F	60° — 71°C
RIBS — Beef or Pork	160°F	71°C
VEAL	160° — 175°F	71° — 79°C
HAM	160° — 175°F	71° — 79°C
PORK	160° — 175°F	71° — 79°C
LAMB	160° — 175°F	71° — 79°C
POULTRY		
CHICKEN — Fried/Baked	160° — 175°F	71° — 79°C
DUCK	160° — 175°F	71° — 79°C
TURKEY	160° — 175°F	71° — 79°C
GENERAL	160° — 175°F	71° — 79°C
FISH/SEAFOOD		
FISH — Baked/Fried	160° — 175°F	71° — 79°C
LOBSTER	160° — 175°F	71° — 79°C
SHRIMP — Fried	160° — 175°F	71° — 79°C
BAKED GOODS		
BREADS/ROLLS	120° — 140°F	49° — 60°C
MISCELLANEOUS		
CASSEROLES	160° — 175°F	71° — 79°C
DOUGH — Proofing	80° — 100°F	27° — 38°C
EGGS — Fried	150° — 160°F	66° — 71°C
FROZEN ENTREES	160° — 175°F	71° — 79°C
HORS D'OEUVRES	160° — 180°F	71° — 82°C
PASTA	160° — 180°F	71° — 82°C
PIZZA	160° — 180°F	71° — 82°C
POTATOES	180°F	82°C
PLATED MEALS	180°F	82°C
SAUCES	140° — 200°F	60° — 93°C
SOUP	140° — 200°F	60° — 93°C
VEGETABLES	160° — 175°F	71° — 79°C
The holding temperatures listed are suggested guidelines only.		

CLEANING AND PREVENTIVE MAINTENANCE

PROTECTING STAINLESS STEEL SURFACES



It is important to guard against corrosion in the care of stainless steel surfaces.

Harsh, corrosive, or inappropriate chemicals can completely destroy the

protective surface layer of stainless steel. Abrasive pads, steel wool, or metal implements will abrade surfaces causing damage to this protective coating and will eventually result in areas of corrosion. Even water, particularly hard water that contains high to moderate concentrations of chloride, will cause oxidation and pitting that result in rust and corrosion. In addition, many acidic foods spilled and left to remain on metal surfaces are contributing factors that will corrode surfaces.

Proper cleaning agents, materials, and methods are vital to maintaining the appearance and life of this appliance. Spilled foods should be removed and the area wiped as soon as possible but at the very least, a minimum of once a day. Always thoroughly rinse surfaces after using a cleaning agent and wipe standing water as quickly as possible after rinsing.

CLEANING AGENTS

Use non-abrasive cleaning products designed for use on stainless steel surfaces. Cleaning agents must be chloride-free compounds and must not contain quaternary salts. Never use hydrochloric acid (muriatic acid) on stainless steel surfaces. Always use the proper cleaning agent at the manufacturer's recommended strength. Contact your local cleaning supplier for product recommendations.

CLEANING MATERIALS

The cleaning function can usually be accomplished with the proper cleaning agent and a soft, clean cloth. When more aggressive methods must be employed, use a non-abrasive scouring pad on difficult areas and make certain to scrub with the visible grain of surface metal to avoid surface scratches. Never use wire brushes, metal scouring pads, or scrapers to remove food residue.

	<p>! CAUTION</p> <p>TO PROTECT STAINLESS STEEL SURFACES, COMPLETELY AVOID THE USE OF ABRASIVE CLEANING COMPOUNDS, CHLORIDE BASED CLEANERS, OR CLEANERS CONTAINING QUATERNARY SALTS. NEVER USE HYDROCHLORIC ACID (MURIATIC ACID) ON STAINLESS STEEL. NEVER USE WIRE BRUSHES, METAL SCOURING PADS OR SCRAPERS.</p>
---	--

CARE AND CLEANING

The cleanliness and appearance of this unit will contribute considerably to operating efficiency and savory, appetizing food. Good equipment that is kept clean works better and lasts longer.

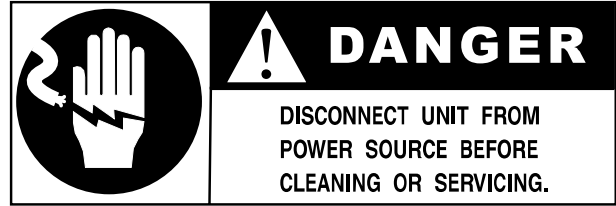

CLEAN THE UNIT THOROUGHLY AFTER EACH USE

1. Turn lights and adjustable thermostat(s) to the "OFF" position. Disconnect unit from power source, and let cool.
2. Remove, cover or wrap, and store unused products under refrigeration.
3. Remove all detachable items such as wire shelves, side racks, and any drip pan. Clean these items separately.
4. Clean interior with a damp cloth or sponge and any good commercial detergent at the recommended strength.
5. Spray heavily soiled areas with a water soluble degreaser and let stand for 10 minutes, then remove soil with a plastic scouring pad.



NOTE: Avoid the use of abrasive cleaning compounds, chloride based cleaners, or cleaners containing quaternary salts. **Never** use hydrochloric acid (muriatic acid) on stainless steel.

6. Clean control panel, door vents, door handles, and door gaskets thoroughly since these areas harbor food debris.
7. Rinse surfaces by wiping with sponge and clean warm water.
8. Remove excess water with sponge and wipe dry with a clean cloth or air dry. Leave door open until interior is completely dry. Replace shelves.
9. Interior can be wiped with a sanitizing solution after cleaning and rinsing. This solution must be approved for use on stainless steel food contact surfaces.
10. To help maintain the protective film coating on polished stainless steel, clean the exterior of the cabinet with a cleaner recommended for stainless steel surfaces. Spray the cleaning agent on a clean cloth and wipe with the grain of the stainless steel.
11. Clean glass with a window cleaner.



SANITATION

Food flavor and aroma are usually so closely related that it is difficult, if not impossible, to separate them. There is also an important, inseparable relationship between cleanliness and food flavor. Cleanliness, top operating efficiency, and appearance of equipment contribute considerably to savory, appetizing foods. Good equipment that is kept clean, works better and lasts longer.

Most food imparts its own particular aroma and many foods also absorb existing odors. Unfortunately, during this absorption, there is no distinction between GOOD and BAD odors. The majority of objectionable flavors and odors troubling food service operations are caused by bacteria growth. Sourness, rancidity, mustiness, stale or other OFF flavors are usually the result of germ activity.

The easiest way to insure full, natural food flavor is through comprehensive cleanliness. This means good control of both visible soil (dirt) and invisible soil (germs). A thorough approach to sanitation will provide essential cleanliness. It will assure an attractive appearance of equipment, along with maximum efficiency and utility. More importantly, a good sanitation program provides one of the key elements in the prevention of food-borne illnesses.

A controlled holding environment for prepared foods is just one of the important factors involved in the prevention of food-borne illnesses. Temperature monitoring and control during receiving, storage, preparation, and the service of foods are of equal importance.

The most accurate method of measuring safe temperatures of both hot and cold foods is by internal product temperature. A quality thermometer is an effective tool for this purpose, and should be routinely used on all products that require holding at a specific temperature.

A comprehensive sanitation program should focus on the training of staff in basic sanitation procedures. This includes personal hygiene, proper handling of raw foods, cooking to a safe internal product temperature, and the routine monitoring of internal temperatures from receiving through service.

Most food-borne illnesses can be prevented through proper temperature control and a comprehensive program of sanitation. Both these factors are important to build quality service as the foundation of customer satisfaction. Safe food handling practices to prevent food-borne illness is of critical importance to the health and safety of your customers. HACCP, an acronym for Hazard Analysis (at) Critical Control Points, is a quality control program of operating procedures to assure food integrity, quality, and safety. Taking steps necessary to augment food safety practices are both cost effective and relatively simple. While HACCP guidelines go far beyond the scope of this manual, additional information is available by contacting:

**Center for Food Safety and Applied Nutrition
Food and Drug Administration
1-888-SAFEFOOD**

INTERNAL FOOD PRODUCT TEMPERATURES		
HOT FOODS		
DANGER ZONE	40° TO 140°F	(4° TO 60°C)
CRITICAL ZONE	70° TO 120°F	(21° TO 49°C)
SAFE ZONE	140° TO 165°F	(60° TO 74°C)
COLD FOODS		
DANGER ZONE	ABOVE 40°F	(ABOVE 4°C)
SAFE ZONE	36°F TO 40°F	(2°C TO 4°C)
FROZEN FOODS		
DANGER ZONE	ABOVE 32°F	(ABOVE 0°C)
CRITICAL ZONE	0° TO 32°F	(-18° TO 0°C)
SAFE ZONE	0°F OR BELOW	(-18°C OR BELOW)

ERROR CODE DISPLAYS

Open-Circuited

If "000" is displayed in the Error Code L.E.D., the sensor is open-circuited. Follow Trouble Shooting Guide instructions in this Operation and Care Manual.

Short-Circuited

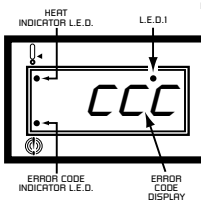

If "CCC" is displayed in the Error Code L.E.D., the sensor is short-circuited. Follow Trouble Shooting Guide instructions in this Operation and Care Manual.

ERROR CODE INDICATOR L.E.D.

If either of the above mentioned errors codes should occur, the Error Code Indicator L.E.D. will be illuminated and remain so until error is cleared.

CAUTION

The unit should be unplugged and a qualified service technician should be consulted if any of the following situations occur:

- The Heat Indicator L.E.D. does not illuminate after normal start-up.
- The warming cabinet does not hold the temperature as set.
- The warming cabinet fails to heat with the L.E.D. illuminated.
- The cabinet heats continuously with the control "OFF".

Refer to Trouble Shooting Guide in this manual.

ELECTRONIC CONTROL ACCURACY

The electronic control is a precise instrument and is designed to offer trouble-free service. If you suspect the temperature inside the warming cabinet does not match the temperature indicated on the digital display, after stabilizing, follow the instructions listed below.

1. Make certain the power meets the requirements of the appliance, voltage and current rating as indicated on identification tag.
2. Verify the temperature inside the warming cabinet with a quality thermal indicator (digital).
 - A. With the exception of the metal shelves, completely empty the warming cabinet.
 - B. Make certain the sensor, located inside the warming cabinet at the ceiling, is completely clean.
 - C. Suspend the thermal indicator in the center of the warming cabinet.
 - D. Allow the temperature, set on the electronic thermostat, to stabilize for a minimum of one hour before comparing the digital display with the reading on the thermal indicator.

DO NOT OPEN THE CABINET DOOR(S) DURING THE TEMPERATURE STABILIZATION PERIOD.

If the reading on the thermal indicator does not match the digital display, there may be a problem with the air sensor. See troubleshooting guide in this manual; or call the factory service department for advice.



SERVICE



This chart is provided for the assistance of *qualified technicians only* and is not intended for use by untrained or unauthorized service personnel. If your unit is not operating properly, check the following before calling your authorized service agent. Check the power applied to the unit. Plug in outlet? Fuse OK?

Do not attempt to repair or service beyond this point. Contact manufacturer for nearest authorized service agent. Repairs made by any other service agent without prior authorization by manufacturer will void the warranty on the unit.

Trouble Shooting Guide

Error Code	Possible Cause	Action Required
<p>1. Control displays "OOO" or "PFO".</p>	<p>A. Sensor is open circuited.</p> <p>B. Associated wiring is open circuited.</p> <p>C. Control is faulty.</p>	<p>Detach the sensor from the terminal block. Use an Ohm meter to measure the resistance of the sensor. Check sensor at 32°F (0°C) using a container of ice water. If Ohm reading is 100, replace display. If Ohm reading is not 100, replace sensor.</p> <p>Check wires for integrity. Check for proper and secure connections at the thermostat and terminal block. If necessary, re-secure the faulty connections.</p> <p>Energize system after the above steps have been completed. If control still reads "OOO or PFO", contact factory.</p>
<p>2. Control displays "CCC" or "PFC".</p>	<p>A. Sensor is short circuited.</p> <p>B. Associated wiring is short circuited.</p> <p>C. Control is faulty.</p>	<p>Detach the sensor from the terminal block. Use an Ohm meter to measure the resistance of the sensor. Check sensor at 32°F (0°C) using a container of ice water. If Ohm reading is 100, replace display. If Ohm reading is not 100, replace sensor.</p> <p>Check wires for integrity. Check for proper and secure connections at the thermostat and terminal block. If necessary, re-secure the faulty connections.</p> <p>Energize system after the above steps have been completed. If control still reads "CCC or PFC", contact factory.</p>
<p>3. Unit does not operate.</p>	<p>A. Insufficient power supply.</p> <p>B. Defective power cord or plug.</p>	<p>Check power source.</p> <p>Check and replace if necessary.</p>
<p>4. No display in electronic control.</p>	<p>A. Faulty power supply board.</p> <p>B. Faulty electronic control.</p>	<p>Check line voltage for 24V across pins 6 and 7 on the power supply board.</p> <p>Replace control.</p>
<p>5. Cannot control temperature but sensor and electronic control check OK.</p>	<p>A. Faulty relay.</p> <p>B. Heating element sensor.</p>	<p>Replace relay.</p> <p>Replace element.</p>
<p>6. Temperature readout incorrect.</p>	<p>A. Dirty or faulty sensor.</p> <p>B. Faulty control.</p>	<p>Detach the sensor from the terminal block. Use an Ohm meter to measure the resistance of the sensor. Check sensor at 32°F (0°C) using a container of ice water. If Ohm reading is 100, replace display. If Ohm reading is not 100, replace sensor.</p>

CAUTION

THIS SECTION IS PROVIDED FOR THE ASSISTANCE OF QUALIFIED SERVICE TECHNICIANS ONLY AND IS NOT INTENDED FOR USE BY UNTRAINED OR UNAUTHORIZED SERVICE PERSONNEL.

SERVICE

600-LVD — REACH-IN

600-LVD/PT — PASS-THRU

5/20/03

5/20/03

PART DESCRIPTION	UNIT QTY.	ALTO-SHAAM PART. NO.	PART DESCRIPTION	UNIT QTY.	ALTO-SHAAM PART. NO.
1. CASING, OUTER - RED (600-LVD)	1	12243	1. CASING, OUTER - RED (600-LVD/PT)	1	12243
CASING, OUTER - WHITE (LVD-60)	1	13048	CASING, OUTER - WHITE (LVD-60/P)	1	13048
CASING MOUNTING SCREWS	2	SC-2425	CASING MOUNTING SCREWS	2	SC-2425
2. CASING, CONTROL COVER - RED (600-LVD)	1	12244	2. CASING, CONTROL COVER - RED (600-LVD/PT)	1	12244
CASING, CONTROL COVER - WHITE (LVD-60)	1	13049	CASING, CONTROL COVER - WHITE (LVD-60/P)	1	13049
CASING MOUNTING SCREWS	2	SC-2425	CASING MOUNTING SCREWS	2	SC-2425
* THREADED BUMPER (not shown)	4	BM-22606	* THREADED BUMPER (not shown)	4	BM-22606
3. SNAP-IN POCKET PULLS	4	PL-22607	3. SNAP-IN POCKET PULLS	4	PL-22607
4. INSULATION: 20" X 90" (508mm X 2286mm)	1	IN-22364	4. INSULATION: 20" X 90" (508mm X 2286mm)	1	IN-22364
5. CABLE CONNECTION HARDWARE			5. CABLE CONNECTION HARDWARE		
6. HEATING CABLE:			6. HEATING CABLE:		
LENGTH 111' (33833mm), 125V	1	CB-3045	LENGTH 111' (33833mm), 125V	1	CB-3045
LENGTH 134' (40843mm), 230V	1	CB-3045	LENGTH 134' (40843mm), 230V	1	CB-3045
7. FAN, 125V (not shown)	1	FA-3973	7. FAN, 125V (not shown)	1	FA-3973
FAN, 230V (not shown)	1	FA-3974	FAN, 230V (not shown)	1	FA-3974
FAN MOUNTING SCREWS	4	SC-2459	FAN MOUNTING SCREWS	4	SC-2459
8. POWER SWITCH	1	SW-3962	8. POWER SWITCH	1	SW-3962
9. CONTROL CONNECTION INCLUDES:			9. CONTROL CONNECTION INCLUDES:		
THERMOSTAT, 125V, 230V	1	TT-33563	THERMOSTAT, 125V, 230V	1	TT-33563
SENSOR	1	SN-33541	SENSOR	1	SN-33541
METAL SENSOR GUARD	1	1496	METAL SENSOR GUARD	1	1496
TRANSFORMER, 115/230V	1	TN-33266	TRANSFORMER, 115/230V	1	TN-33266
RELAY	1	RL-3736	RELAY	1	RL-3736
10. CONTROL PANEL OVERLAY - BLUE	1	PE-22622	10. CONTROL PANEL OVERLAY - BLUE	1	PE-22622
CUSTOMER PANEL OVERLAY - BLUE	1	PE-22623	CUSTOMER PANEL OVERLAY - BLUE	1	PE-22623
11. DECOR PANELS	2	PE-22621	11. DECOR PANELS	2	PE-22621
PANEL MOUNTING SCREWS	4	SC-2352	PANEL MOUNTING SCREWS	4	SC-2352
12. BULB, 10 WATTS, 12 VOLT	5	LP-33268	12. BULB, 10 WATTS, 12 VOLT	5	LP-33268
LAMP ASSEMBLY WITH BULB (NOT SHOWN)	5	LP-33267	LAMP ASSEMBLY WITH BULB (NOT SHOWN)	5	LP-33267
13. CORDSET, 125V	1	CD-3959	13. CORDSET, 125V	1	CD-3959
CORDSET, 230V (TYPE HO7 RN-F-VDE-HAR)	1	CD-3922	CORDSET, 230V (TYPE HO7 RN-F-VDE-HAR)	1	CD-3922
14. DOOR LATCH, MAGNETIC	8	LT-23187	14. DOOR LATCH, MAGNETIC	8	LT-23187
MAGNETIC CATCH		LT-24123	MAGNETIC CATCH		LT-24123
15. DOOR HINGE	6	HG-22611	15. DOOR HINGE	4	HG-22611
HINGE MOUNTING SCREWS	12	SC-2352	HINGE MOUNTING SCREWS	12	SC-2352
16. BACK GLASS	1	4927	16. GLASS DOOR	2	4929
GLASS DOOR	1	4929	DOOR HINGE WASHER	2	WS-2893
DOOR HINGE WASHER	1	WS-2893	GLASS DOOR ASSB. INCLUDES...		
GLASS DOOR ASSB. INCLUDES...			—HINGE PIVOT PIN	4	PI-23190
—HINGE PIVOT PIN	2	PI-23190	—HANDLE	2	HD-22604
—HANDLE	1	HD-22604	—HANDLE MOUNTING ADHESIVE: 15" (381mm)	1	TA-22122
—HANDLE MOUNTING ADHESIVE: 15" (381mm)	1	TA-22122	—HANDLE MOUNTING SCREWS	4	SC-23681
—HANDLE MOUNTING SCREWS	2	SC-23681	—GASKET: 8' (2438mm)	2	GS-2891
—GASKET: 8' (2438mm)	1	GS-2891	17. WIRE SHELVES, CHROME PLATED	12	SH-22608
18. WIRE SHELVES, CHROME PLATED	12	SH-22608	SHELF STUDS	48	ST-22605
SHELF STUDS	48	ST-22605			

SERVICE VIEWS — ON FOLLOWING PAGES.



Cable Heating Service Kit, 125V No. 4879

<small>includes:</small>	
CB-3045	Cable Heating Element 112 feet
CR-3226	Ring Connector 6
IN-3488	Insulation Corner 1 foot
BU-3105	Shoulder Bushing 6
BU-3106	Cup Bushing 6
SL-3063	Insulating Sleeve 6
TA-3540	Electrical Tape 1 roll
ST-2439	10-32 Stud 6
NU-2215	Nut, Hex. 12

Cable Heating Service Kit, 230V No. 4880

<small>includes:</small>	
CB-3045	Cable Heating Element 134 feet
CR-3226	Ring Connector 4
IN-3488	Insulation Corner 1 foot
BU-3105	Shoulder Bushing 4
BU-3106	Cup Bushing 4
SL-3063	Insulating Sleeve 4
TA-3540	Electrical Tape 1 roll
ST-2439	10-32 Stud 4
NU-2215	Nut, Hex. 8

SERVICE

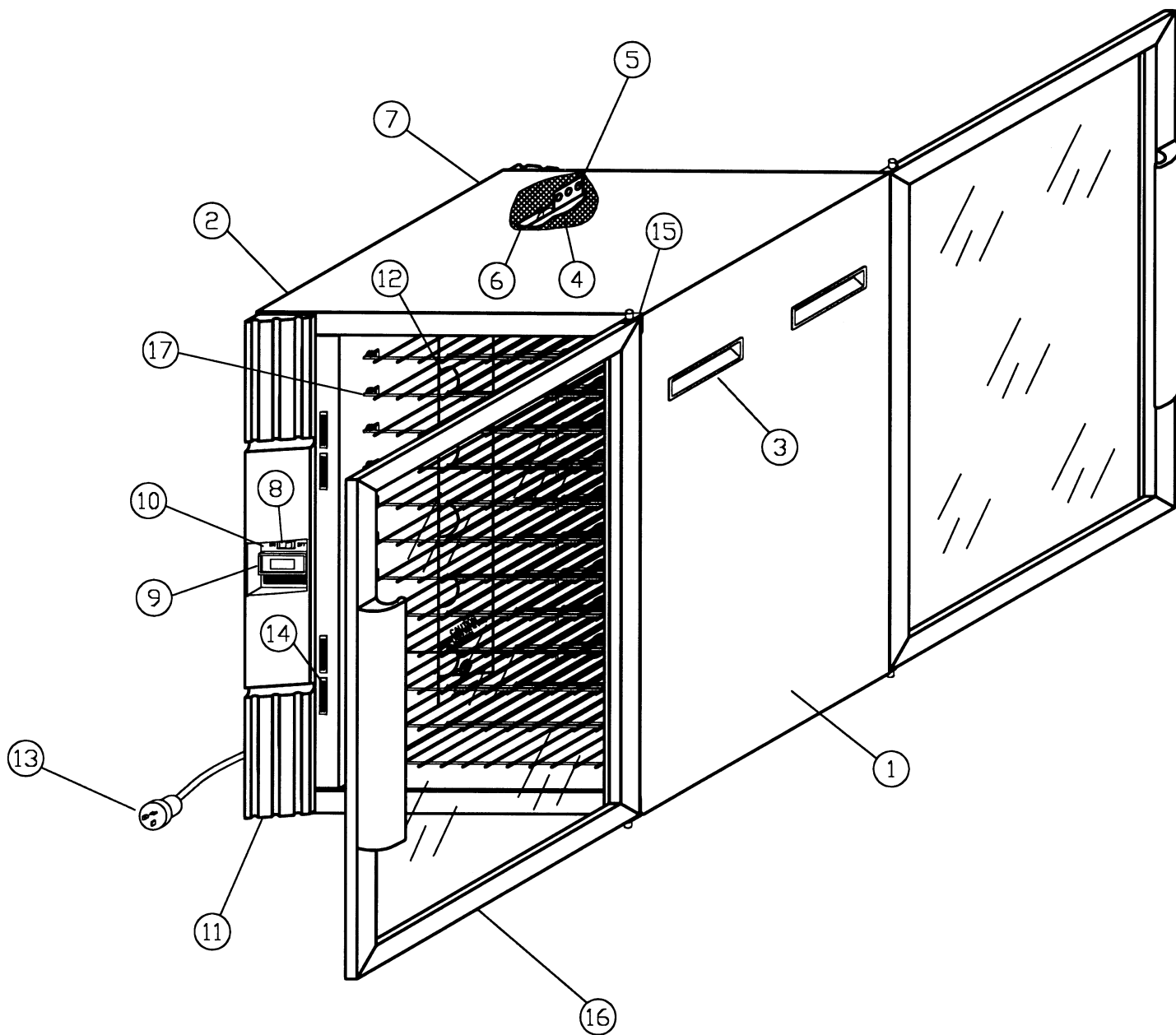

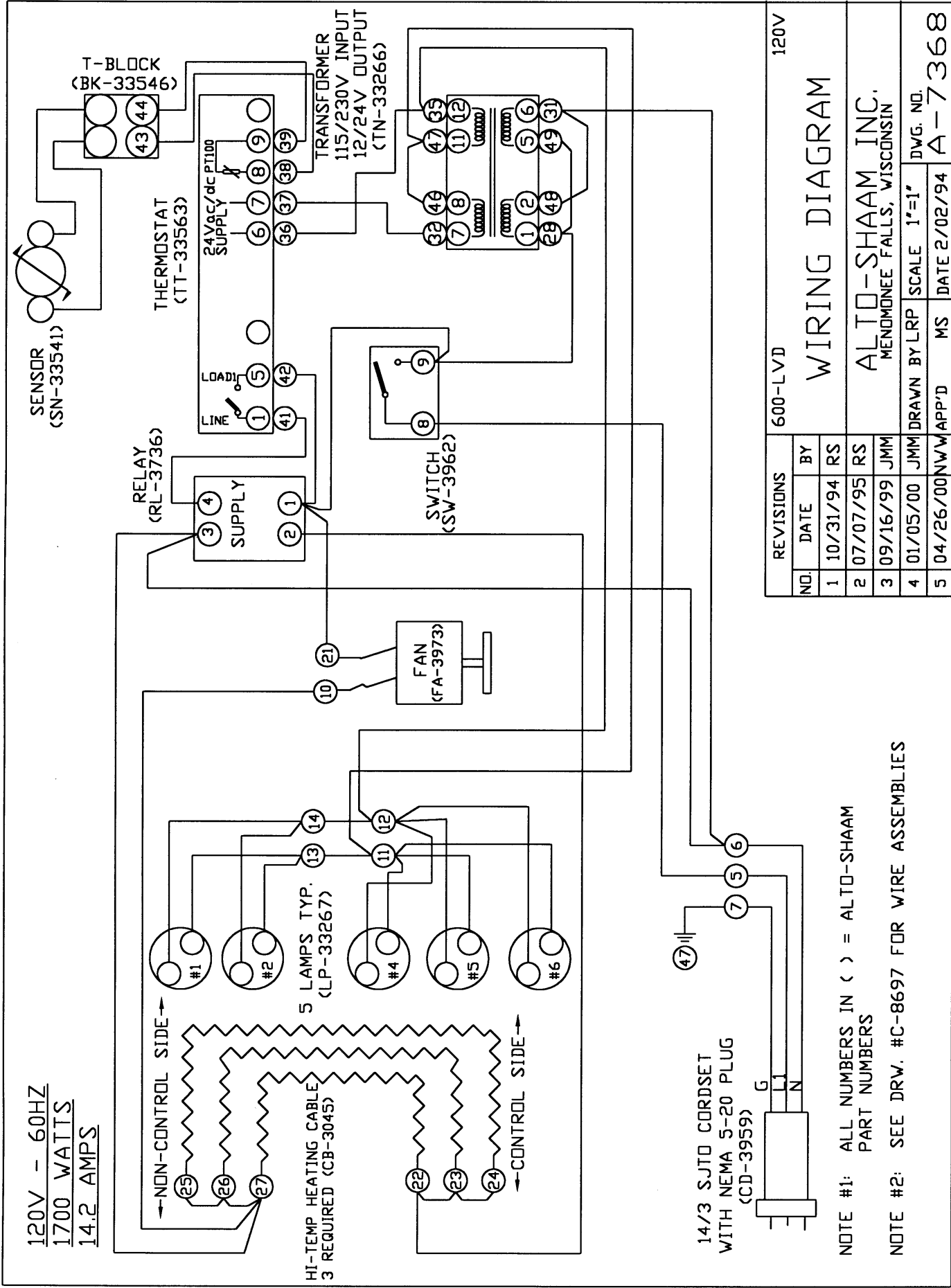

120V - 60HZ
 1700 WATTS
 14.2 AMPS

HI-TEMP HEATING CABLE
 3 REQUIRED (CB-3045)

5 LAMPS TYP.
 (LP-33267)

14/3 SJTO CORDSET
 WITH NEMA 5-20 PLUG
 (CD-3959)

NOTE #1: ALL NUMBERS IN () = ALTO-SHAAM PART NUMBERS

NOTE #2: SEE DRW. #C-8697 FOR WIRE ASSEMBLIES

REVISIONS		600-LVD	120V
NO.	DATE	BY	
1	10/31/94	RS	
2	07/07/95	RS	
3	09/16/99	JMM	
4	01/05/00	JMM	
5	04/26/00	NW	

WIRING DIAGRAM

ALTO-SHAAM INC.
 MENOMONEE FALLS, WISCONSIN

DRAWN BY	LRP	SCALE	1"=1'	DWG. NO.	A-7368
APP'D	MS	DATE	2/02/94		

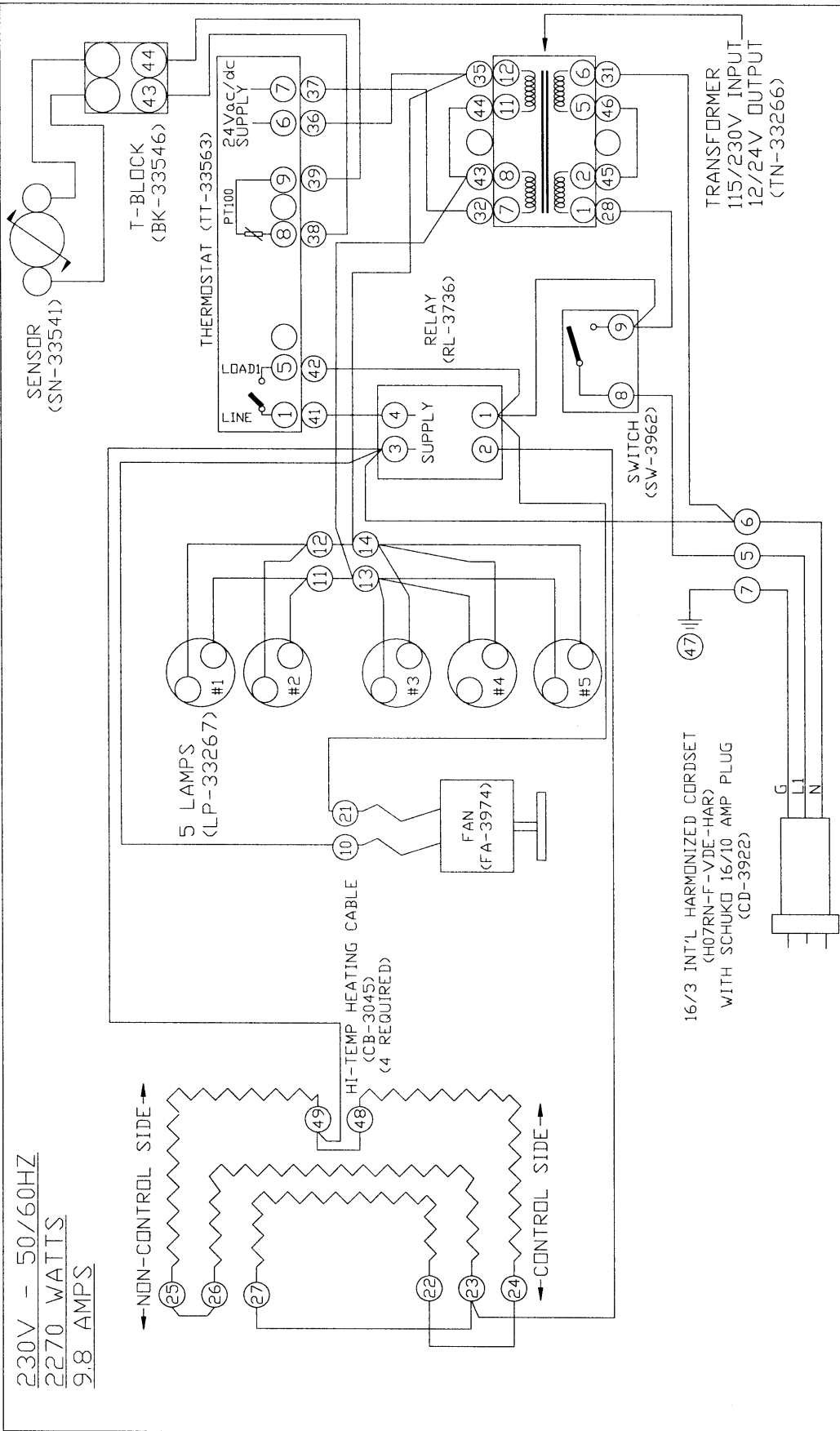

230V - 50/60HZ
 2270 WATTS
 9.8 AMPS

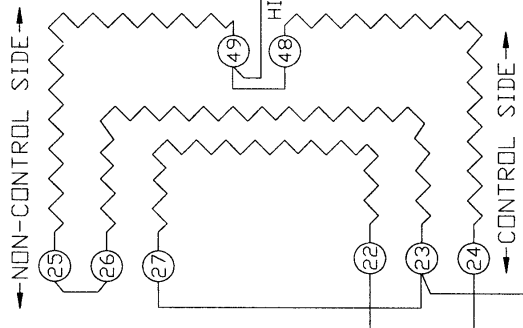

REVISIONS		600-LVD	230V
NO.	DATE	BY	
1	10/31/94	RS	
2	09/16/99	JMM	
3	01/05/00	JMM	
4	04/26/00	NW	DRAWN
5	05/29/03	CJB	APP'D

WIRING DIAGRAM

ALTO-SHAAM INC.
 MENOMONEE FALLS, WISCONSIN

NOTE #1: ALL NUMBERS IN () = ALTO-SHAAM PART NUMBERS

NOTE #2: SEE DRW. #C-8698 FOR WIRE ASSEMBLIES

SCALE 1"=1" DWG. NO. A-7369
 DATE 09/22/94

TRANSPORTATION DAMAGE and CLAIMS



LIMITED WARRANTY



All Alto-Shaam equipment is sold F.O.B. shipping point, and when accepted by the carrier, such shipments become the property of the consignee.

Should damage occur in shipment, it is a matter between the carrier and the consignee. In such cases, the carrier is assumed to be responsible for the safe delivery of the merchandise, unless negligence can be established on the part of the shipper.

1. Make an immediate inspection while the equipment is still in the truck or immediately after it is moved to the receiving area. Do not wait until after the material is moved to a storage area.
2. Do not sign a delivery receipt or a freight bill until you have made a proper count and inspection of all merchandise received.
3. Note all damage to packages directly on the carrier's delivery receipt.
4. Make certain the driver signs this receipt. If he refuses to sign, make a notation of this refusal on the receipt.
5. If the driver refuses to allow inspection, write the following on the delivery receipt:
Driver refuses to allow inspection of containers for visible damage.
6. Telephone the carrier's office immediately upon finding damage, and request an inspection. Mail a written confirmation of the time, date, and the person called.
7. Save any packages and packing material for further inspection by the carrier.
8. Promptly file a written claim with the carrier and attach copies of all supporting paperwork.

We will continue our policy of assisting our customers in collecting claims which have been properly filed and actively pursued. We cannot, however, file any damage claims for you, assume the responsibility of any claims, or accept deductions in payment for such claims.

Alto-Shaam, Inc. warrants to the original purchaser that any original part that is found to be defective in material or workmanship will, at Alto-Shaam's option, subject to provisions hereinafter stated, be replaced with a new or rebuilt part.

The labor warranty remains in effect one (1) year from installation or fifteen (15) months from the shipping date, whichever occurs first. Alto-Shaam will bear normal labor charges performed during standard business hours, and excluding overtime, holiday rates or any additional fees.

The parts warranty remains in effect for one (1) year from installation or fifteen (15) months from the shipping date, whichever occurs first.

However, the heating element on Halo Heat® cook/hold ovens and the refrigeration compressor on Alto-Shaam Quickchillers™ are warranted for a period of five (5) years from installation. The labor warranty is the same as stated above; namely, for one (1) year from installation or fifteen (15) months from the shipping date, whichever occurs first.

THIS WARRANTY DOES NOT APPLY TO:

1. Calibration.
2. Replacement of light bulbs and/or the replacement of display case glass due to damage of any kind.
3. Equipment damage caused by accident, shipping, improper installation or alteration.
4. Equipment used under conditions of abuse, misuse, carelessness or abnormal conditions, including but not limited to equipment subjected to harsh or inappropriate chemicals including but not limited to compounds containing chloride or quaternary salts, poor water quality, or equipment with missing or altered serial numbers.
5. Damage incurred as a direct result of poor water quality, inadequate maintenance of steam generators and/or surfaces affected by water quality. Water quality and required maintenance of steam generating equipment is the responsibility of the owner/operator.
6. Damage caused by use of any cleaning agent other than Alto-Shaam's Combitherm® Cleaner, including but not limited to damage due to chlorine or other harmful chemicals. Use of Alto-Shaam's Combitherm® Cleaner on Combitherm® ovens is highly recommended.
7. Any losses or damage resulting from malfunction, including loss of product or consequential or incidental damages of any kind.
8. Equipment modified in any manner from original model, substitution of parts other than factory authorized parts, removal of any parts including legs, or addition of any parts.

This warranty is exclusive and is in lieu of all other warranties, expressed or implied, including the implied warranties of merchantability and fitness for a particular purpose. In no event shall Alto-Shaam be liable for loss of use, loss of revenue or profit, or loss of product, or for any indirect or consequential damages. No person except an officer of Alto-Shaam, Inc. is authorized to modify this warranty or to incur on behalf of Alto-Shaam any other obligation or liability in connection with Alto-Shaam equipment.

ALTO-SHAAM, INC.

RECORD THE MODEL AND SERIAL NUMBER OF THE APPLIANCE FOR EASY REFERENCE.
ALWAYS REFER TO BOTH MODEL AND SERIAL NUMBER IN ANY CONTACT WITH ALTO-SHAAM REGARDING THIS APPLIANCE.

Model: _____ Date Installed: _____
Voltage: _____ Purchased From: _____
Serial Number: _____

W164 N9221 Water Street • P.O. Box 450 • Menomonee Falls, Wisconsin 53052-0450 • U.S.A.

PHONE: 262.251.3800 • 800.558-8744 USA/CANADA

FAX: 262.251.7067 • 800.329.8744 U.S.A. ONLY

WEBSITE: www.alto-shaam.com

PRINTED IN U.S.A.