

ALTO SHAAM®

OPERATION and CARE MANUAL



HOT FOOD CARVING TABLE

MODEL: 300-TMC

HALO HEAT COOK/HOLD/SERVE SYSTEMS



W164 N9221 Water Street • P.O. Box 450 • Menomonee Falls, Wisconsin 53052-0450 U.S.A.

PHONE: 262.251.3800

FAX: 262.251.7067 • 800.329.8744 U.S.A. ONLY

WEBSITE:

800.558.8744 U.S.A./CANADA

262.251.1907 INTERNATIONAL

www.alto-shaam.com

ALTO-SHAAM - HOT FOOD CARVING TABLE

UNPACKING and SET-UP

The Alto-Shaam Hot Food Carving Table has been thoroughly tested, checked for calibration, and inspected to insure only the highest quality unit is provided.

When you receive your unit, check for any possible shipping damage and report it at once to the delivering carrier. See *Transportation Damage and Claims* section located in this manual.

Save all the information and instructions packed inside the carton. Complete and return the warranty card to the factory as soon as possible to assure prompt service in the event of a warranty parts and labor claim.

NOTE: Any and all claims for warranty must include the full model number and serial number of the unit.



ELECTRICAL INSTALLATION

1. An identification tag is permanently mounted on the unit.
2. Plug the table into a properly grounded receptacle **ONLY**. Arcing will occur when connecting or disconnecting unit unless all controls are in the OFF position. If necessary, a proper receptacle or outlet configuration, as required for the unit, must be installed by a licensed electrician in accordance with applicable, local electrical codes.
3. Position the unit so that the cord is easily accessible in case of an emergency.

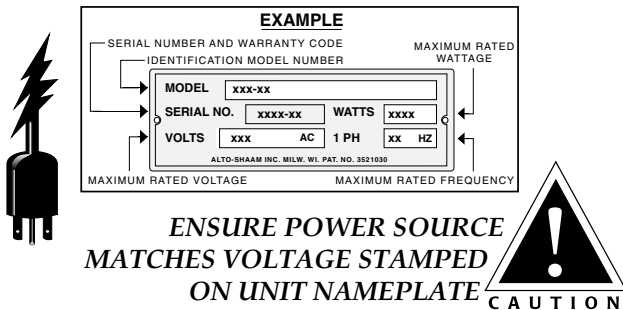

START-UP

1. Before operating the unit, clean the interior and exterior with a damp cloth and mild soap solution. Rinse well.
2. Clean the sneeze guard with soap or mild detergent and water. Dry with a clean, damp chamois. *Do not use commercial or household cleaners containing ammonia.* To avoid scratching, do not use dry cloth or scouring compounds.
3. This unit is designed to be mounted directly on top of an Alto-Shaam decorator cart or it can be used as a free-standing unit. Prior to use, the free standing unit must be mounted on the legs furnished. Otherwise, mount the unit on the optional cart sealing the bottom perimeter with a R.T.V. or silastic meeting N.S.F. requirements. Warranty will become null and void if these directions are not followed.
4. The unit should NOT be installed in any area where it may be affected by steam, grease, dripping water, high temperatures or any other severely adverse conditions.

OPERATIONAL PROCEDURES

1. **DO NOT ADD WATER TO THE UNIT**
Halo Heat units maintain a constant but gentle temperature and eliminate much of the moisture loss associated with conventional holding methods. Because of this gentle heat, it is not necessary to add water to the hot food table. As a matter of fact, adding water is not recommended since water will accelerate the deterioration of the product, presents an electrical hazard, and may damage the unit.
2. **PLACE DIVIDER BARS & PANS INTO THE UNIT**
Refer to the pan layout diagrams for different types of pan accommodations. A complete pan configuration layout is located in this manual. **It is VERY important to note** that no matter what type of pan configuration chosen, pan separator bars or divider bars must be used to close all gaps between pans, and all gaps between the pans and the edges of the table. If these gaps are not closed, heat can be pulled out of the bottom of the unit. As a consequence, heat distribution will be uneven, and uniform temperature will be difficult to maintain. If needed, additional pan divider bars are available.
3. **PREHEAT BY SETTING THE ADJUSTABLE THERMOSTATS TO NUMBER "10"**
An indicator light will illuminate when each thermostat is turned ON. These indicators will remain lit as long as the unit is preheating or calling for heat. The unit should be preheated, at the number 10 setting, for a minimum of twenty minutes before loading the table with food. When preheating is completed, or whenever the unit reaches any temperature set by the operator between 1 and 10, the indicator light(s) will go OUT. If a carving shelf is used, turn its lights on.
4. **LOAD HOT FOODS ON THE CARVING TABLE**
Be certain only hot food is transferred into the carving table. Before loading food into the table, use a pocket-type meat thermometer to make certain all products have reached an internal temperature of 140° to 160° F. (60° to 71°C). If any food product is not at proper serving temperature, use a Halo Heat cooking and holding oven, set at 250° to 275°F (121° to 135°C), or a Combi-therm oven to bring the product within the correct temperature range.
5. **RESET THERMOSTATS AS NEEDED**
After all products are loaded into the hot food table, reset the thermostat(s) to the number "8" setting. **THIS WILL NOT NECESSARILY BE THE FINAL SETTING.** Since proper temperature range depends on the type of products and the quantities being held, it is necessary to periodically use a pocket thermometer to check each item to make certain the correct temperatures are being maintained. Proper temperature range is between 140° and 160°F (60° and 71°C). Normally, this will require a

OPERATIONAL PROCEDURES Continued...

thermostat setting of between number "6" and "8", although a higher or lower setting may sometimes be required.

6. SERVE FRESH HOT FOOD

Keep hot foods looking fresh. Occasionally stir or rotate foods as needed. Wipe spills immediately to assure maximum eye appeal and to ease end-of-the-day cleanup.

CARE and CLEANING

The cleanliness and appearance of this equipment will contribute considerably to operating efficiency and savory, appetizing food. Good equipment that is kept clean works better and lasts longer.



THOROUGHLY CLEAN EQUIPMENT AFTER EACH USE

1. Turn lights and adjustable thermostat(s) to the "OFF" position. Disconnect from the power source.
2. Remove, cover or wrap, and store unused products under refrigeration. Let unit cool.
3. Clean pan divider bars with mild soap solutions only. Clean the metal surfaces with a damp cloth and any good alkaline or alkaline chlorinated based commercial detergent or grease solvent at the recommended strength. Use a plastic scouring pad or oven cleaner for difficult areas. Avoid the use of abrasive cleaning compounds, chloride based cleaners, or cleaners containing quaternary salts. Rinse carefully to remove all soap or detergent residue.



Note: Never use hydrochloric acid (muriatic acid) on stainless steel.

4. If a carving shelf is used, remove its cutting board after each use. Clean and sanitize separately. Air dry the board on a clean, flat surface to prevent board from warping. If the board becomes warped, heating will restore flexibility to facilitate flattening. Warped boards may be heated on the carving shelf surface, or in a preheated Combitherm oven/steamer for 10 minutes on the steam program, or in a preheated cook/hold oven for 15 minutes at 250°F (121°C).

5. Clean the sneeze guard with soap or mild detergent and water. Dry with a clean damp chamois. Grease and oil may be removed with naphtha or hexane. *Do not use commercial or household cleaners containing ammonia.* To avoid scratching, do not use dry cloths or scouring compounds.

Always follow appropriate state or local health (hygiene) regulations regarding all applicable cleaning and sanitation requirements for equipment



MAKE CERTAIN THE EQUIPMENT
IS DISCONNECTED
FROM THE POWER SOURCE
BEFORE CLEANING OR SERVICING



AT NO TIME SHOULD THE UNIT
BE STEAM CLEANED, WASHED
DOWN OR FLOODED WITH WATER
OR LIQUID SOLUTION. DO NOT
USE WATER JET TO CLEAN.
SEVERE DAMAGE OR ELECTRICAL
HAZARD COULD RESULT, VOID-
ING THE WARRANTY.

SANITATION GUIDELINE

Food flavor and aroma are usually so closely related that it is difficult, if not impossible, to separate them. There is also an important, inseparable relationship between cleanliness and food flavor. Cleanliness, top operating efficiency, and appearance of equipment contribute considerably to savory, appetizing foods. Good equipment that is kept clean, works better and lasts longer.

Most food imparts its own particular aroma and many foods also absorb existing odors. Unfortunately, during this absorption, there is no distinction between GOOD and BAD odors. The majority of objectionable flavors and odors troubling food service operations are caused by bacteria growth. Sourness, rancidity, mustiness, stale or other OFF flavors are usually the result of germ activity.

The easiest way to insure full, natural food flavor is through comprehensive cleanliness. This means good control of both visible soil (dirt) and invisible soil (germs). A thorough approach to sanitation will provide essential cleanliness. It will assure an attractive appearance of equipment, along with maximum efficiency and utility. More importantly, a good sanitation program provides one of the key elements in the prevention of food-borne illnesses.

A controlled holding environment for prepared foods is just one of the important factors involved in the prevention of food-borne illnesses. Temperature monitoring and control during receiving, storage, preparation, and the service of foods are of equal importance.

The most accurate method of measuring safe tempera-

INTERNAL FOOD PRODUCT TEMPERATURES		
HOT FOODS		
DANGER ZONE	40° TO 140°F	(4° TO 60°C)
CRITICAL ZONE	70° TO 120°F	(21° TO 49°C)
SAFE ZONE	140° TO 165°F	(60° TO 74°C)
COLD FOODS		
DANGER ZONE	ABOVE 40°F	(ABOVE 4°C)
SAFE ZONE	36°F TO 40°F	(2°C TO 4°C)
FROZEN FOODS		
DANGER ZONE	ABOVE 32°F	(ABOVE 0°C)
CRITICAL ZONE	0° TO 32°F	(-18° TO 0°C)
SAFE ZONE	0°F OR BELOW	(-18°C OR BELOW)

tures of both hot and cold foods is by internal product temperature. A quality thermometer is an effective

tool for this purpose, and should be routinely used on all products that require holding at a specific temperature.

A comprehensive sanitation program should focus on the training of staff in basic sanitation procedures. This includes personal hygiene, proper handling of raw foods, cooking to a safe internal product temperature, and the routine monitoring of internal temperatures from receiving through service.

Most food-borne illnesses can be prevented through proper temperature control and a comprehensive program of sanitation. Both these factors are important to build quality service as the foundation of customer satisfaction. Safe food handling practices to prevent food-borne illness is of critical importance to the health and safety of your customers. HACCP, an acronym for Hazard Analysis (at) Critical Control Points, is a quality control program of operating procedures to assure food integrity, quality, and safety. Taking steps necessary to augment food safety practices are both cost effective and relatively simple. While HACCP guidelines go far beyond the scope of this manual, additional information is available by contacting the USDA/FDA Food-borne Illness Education Information Center at (301)504-6803.

GENERAL HOLDING GUIDELINE

Chefs, cooks and other specialized food service personnel employ varied methods of cooking. Proper holding temperatures for a specific food product must be based on the moisture content of the product, product density, volume, and proper serving temperatures. Safe holding temperatures must also be correlated with palatability in determining the length of holding time for a specific product.

Halo Heat maintains the maximum amount of product moisture content without the addition of water, water vapor, or steam. Maintaining maximum natural product moisture preserves the natural flavor of the product and provides a more genuine taste. In addition to product moisture retention, the gentle properties of Halo Heat maintain a consistent temperature throughout the cabinet without the necessity of a heat distribution fan, thereby preventing further moisture loss due to evaporation or dehydration.

In an enclosed holding environment, too much moisture content is a condition which can be relieved. A product achieving extremely high temperatures in preparation must be allowed to decrease in temperature before being placed in a controlled holding atmosphere. If the product is not allowed to decrease in temperature, excessive condensation will form increasing the moisture content on the outside of the product.

Most Halo Heat Holding Equipment is provided with a thermostat control between 60° and 200°F (16° to 93°C). If the unit is equipped with vents, close the vents for moist holding and open the vents for crisp holding.

If the unit is equipped with a thermostat indicating a range of between 1 and 10, use a metal-stemmed indicating thermometer to measure the internal temperature of the product(s) being held. Adjust the thermostat setting to achieve the best overall setting based on internal product temperature.

HOLDING TEMPERATURE RANGE		
MEAT	FAHRENHEIT	CELSIUS
BEEF ROAST — Rare	140°F	60°C
BEEF ROAST — Med/Well Done	160°F	71°C
BEEF BRISKET	160° — 175°F	71° — 79°C
CORN BEEF	160° — 175°F	71° — 79°C
PASTRAMI	160° — 175°F	71° — 79°C
PRIME RIB — Rare	140°F	60°C
STEAKS — Broiled/Fried	140° — 160°F	60° — 71°C
RIBS — Beef or Pork	160°F	71°C
VEAL	160° — 175°F	71° — 79°C
HAM	160° — 175°F	71° — 79°C
PORK	160° — 175°F	71° — 79°C
LAMB	160° — 175°F	71° — 79°C
POULTRY		
CHICKEN — Fried/Baked	160° — 175°F	71° — 79°C
DUCK	160° — 175°F	71° — 79°C
TURKEY	160° — 175°F	71° — 79°C
GENERAL	160° — 175°F	71° — 79°C
FISH/SEAFOOD		
FISH — Baked/Fried	160° — 175°F	71° — 79°C
LOBSTER	160° — 175°F	71° — 79°C
SHRIMP — Fried	160° — 175°F	71° — 79°C
BAKED GOODS		
BREADS/ROLLS	120° — 140°F	49° — 60°C
MISCELLANEOUS		
CASSEROLES	160° — 175°F	71° — 79°C
DOUGH — Proofing	80° — 100°F	27° — 38°C
EGGS — Fried	150° — 160°F	66° — 71°C
FROZEN ENTREES	160° — 175°F	71° — 79°C
HORS D'OEUVRES	160° — 180°F	71° — 82°C
PASTA	160° — 180°F	71° — 82°C
PIZZA	160° — 180°F	71° — 82°C
POTATOES	180°F	82°C
PLATED MEALS	180°F	82°C
SAUCES	140° — 200°F	60° — 93°C
SOUP	140° — 200°F	60° — 93°C
VEGETABLES	160° — 175°F	71° — 79°C

THE HOLDING TEMPERATURES LISTED ARE SUGGESTED GUIDELINES ONLY

PAN CONFIGURATIONS

HOT FOOD CARVING TABLE — MODEL 300-TMC/1 & 300-TMC/2

STANDARD PAN DIVIDER and SEPARATOR BARS	ITEM	QUANTITY
PAN DIVIDER BARS	1924	4
HALF & THIRD-SIZE PAN SEPARATOR BARS	1037	5

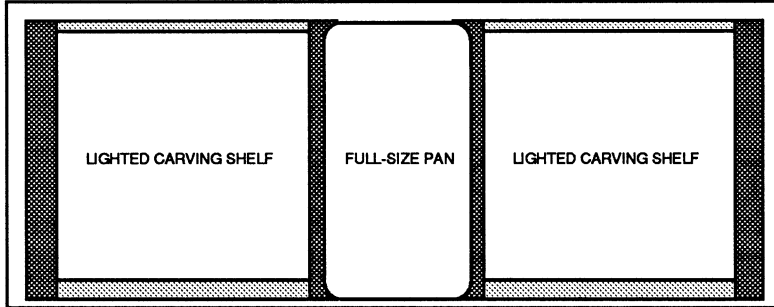

**MODEL 300-TMC
— WITH TWO CARVING STATIONS**

4: PAN DIVIDER BARS — #1924

CAPACITY: 1 FULL-SIZE PAN

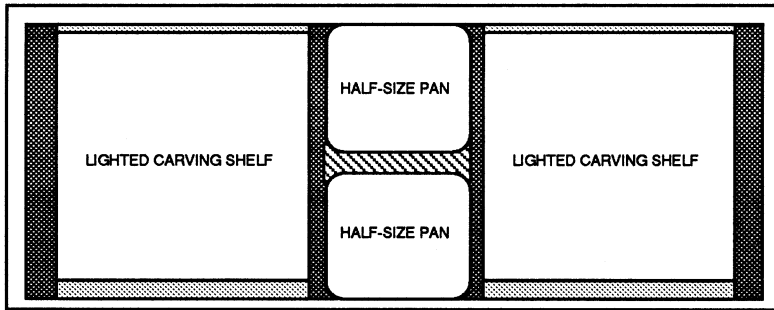

4: PAN DIVIDER BARS — #1924
1: HALF-SIZE SEPARATOR BARS — #1037

CAPACITY: 2 ONE-HALF SIZE PANS

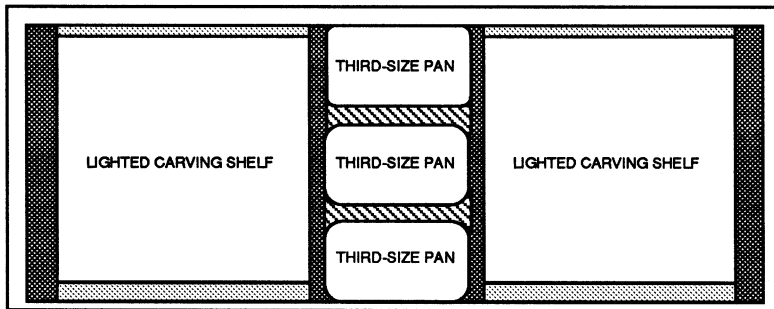

4: PAN DIVIDER BARS — #1924
2: THIRD-SIZE SEPARATOR BARS — #1037

CAPACITY: 3 ONE-THIRD SIZE PANS

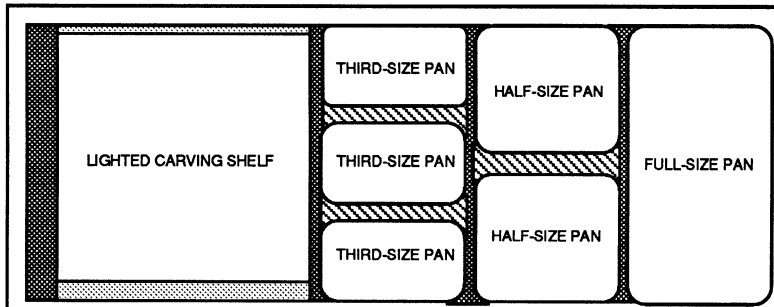

**MODEL 300-TMC
— WITH ONE CARVING STATION**

4: PAN DIVIDER BARS — #1924
2 to 6: PAN SEPARATOR BARS — #1037

CAPACITY: 1 TO 3 FULL-SIZE PANS
2, 4 OR 6 ONE-HALF SIZE PANS
3, 6 OR 9* ONE-THIRD SIZE PANS

*Additional #1037 Pan Separator Bar required.

300-TMC - HOT FOOD CARVING TABLE

The hot food carving table can accommodate one or two carving shelves. The heated carving shelf base is completely removable from the table.

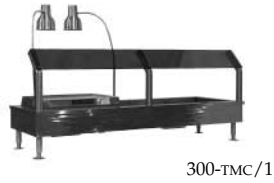

Both the table and carving shelves are individually heated.



The hot food carving table is designed to fit directly on top of an Alto-Shaam decorator cart.

Style #308461 is fully enclosed on all four sides of the cart.



Style #308451 is fully enclosed on three sides of the cart. The fourth side is completely open to the floor and will accommodate the under-cart storage of three Halo Heat holding units on casters.



Style #308441 is fully enclosed on three sides. The fourth side includes two stainless steel shelves.

Options and Accessories

Custom Panel Colors	FACTORY QUOTE
Pocket Thermometer °F	TH-3300
Pocket Thermometer °C	TH-3412
Pan Divider Bar Set		
— Full-Size Pan Dividers (4)	1924
— One-Half Pan Dividers (5)	1037

Heating Cable Replacement Kit

Cable Heating Service Kit	No. 4878
<i>includes:</i>		
CB-3045	Cable Heating Element 72 feet
CR-3226	Ring Connector 4
IN-3488	Insulation Corner 1 foot
BU-3105	Shoulder Bushing 4
BU-3106	Cup Bushing 4
SL-3063	Insulating Sleeve 4
TA-3540	Electrical Tape 1 roll
ST-2439	Stud, 10-32 4
NU-2215	Hex Nut 8

Cart Outside Dimensions

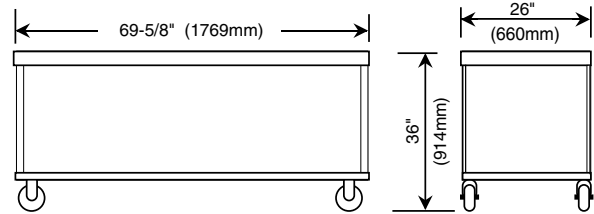

300-TMC SERVICE PARTS LIST Qty/Unit Part No.

Cable, Heating		CB-3045
Control Box, 120V	1	XP-TMC-1955
Control Box, Spot, 120V		XP-TMC-4414
Control Box, Spot, 230V	1	44138
Cordset (125V)	1	CD-33366
Cordset (230V)	1	CD-33469
Inlet (230V)	1	IT-33306
Cutting Board		CONTACT FACTORY
Gasket	1	GS-2750
Insulation	1	IN-2003
Insulation	2	IN-222364
Leg	4	LG-23067
Light Indicator (120V)	2	LI-3027
Light Indicator (230V)	1	LI-3951
Nut, Indicator Light	2	NU-3335
Panel Overlay, 230V	1	PE-24665
Panel Overlay, 120V	1	PE-24666
Sneeze Guard	1	GD-25306
Switch, 120V	1	SW-32487
Switch, 230V	1	SW-33487
Thermostat Knob	2	KN-3473
Thermostat	2	TT-3498
Terminal Block	2	BK-3021
Hex Screw, Head	3	SC-2351
Hex Screw, Trim	24	SC-22730
Hex Screw, Trim	8	SC-24250
Hex Screw, Trim	6	SC-23152
Phil Screw, Truss	8	SC-2425
Phil Screw, Truss	24	SC-2459
Phil Screw, Truss	8	SC-2472
Slot Screw, Pan	6	SC-2162

See following pages for illustrations.

300-TMC - HOT FOOD CARVING TABLE



300-TMC - HOT FOOD CARVING TABLE Control Side

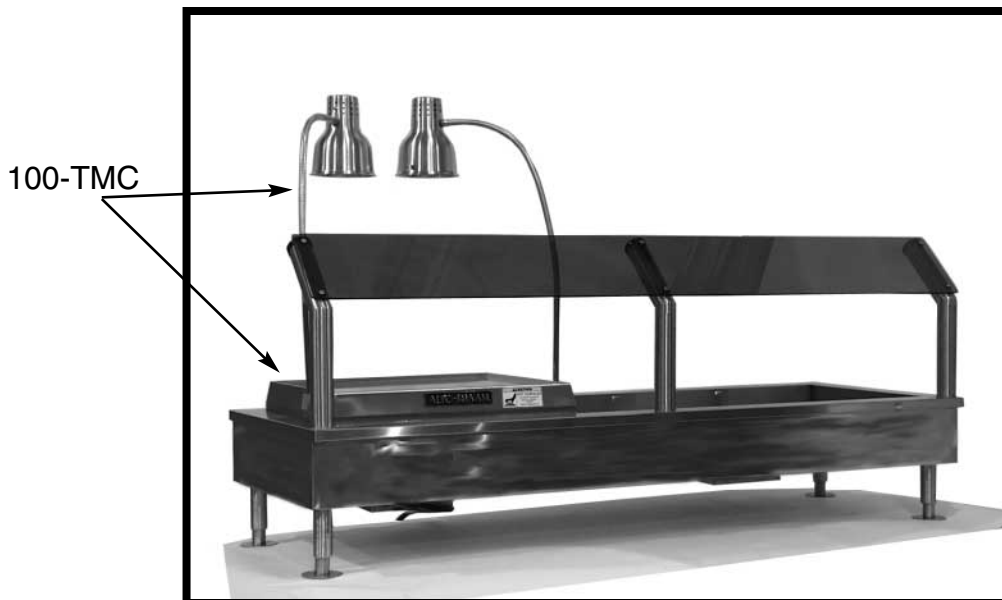

300-TMC/1 - HOT FOOD CARVING TABLE Front of Unit

300-TMC - HOT FOOD CARVING TABLE

Service View

Control Box

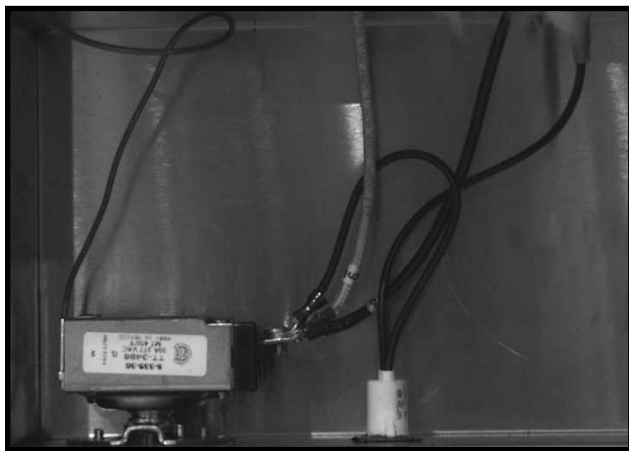

Inside the Control Boxes

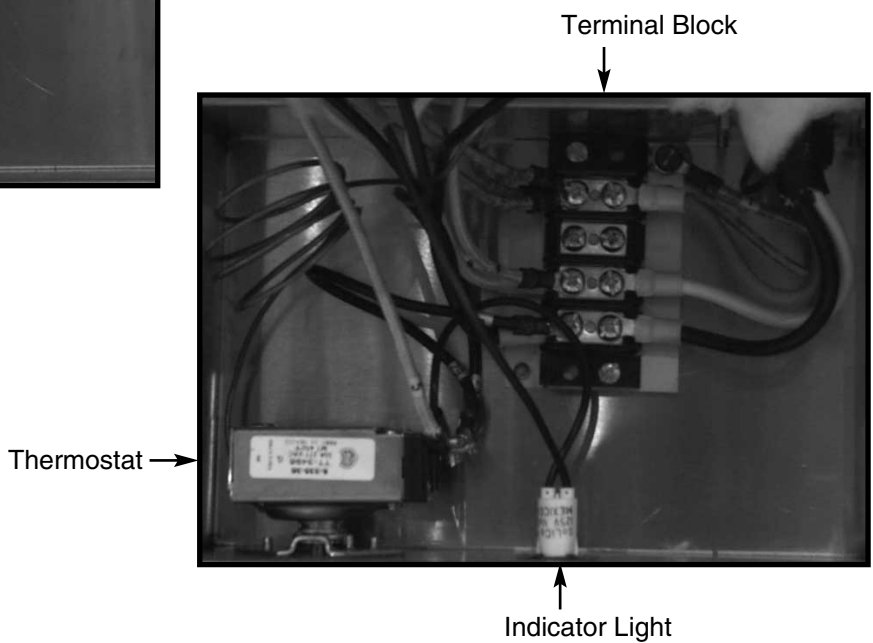

300-TMC - HOT FOOD CARVING TABLE

Service View

Cable Heat Element

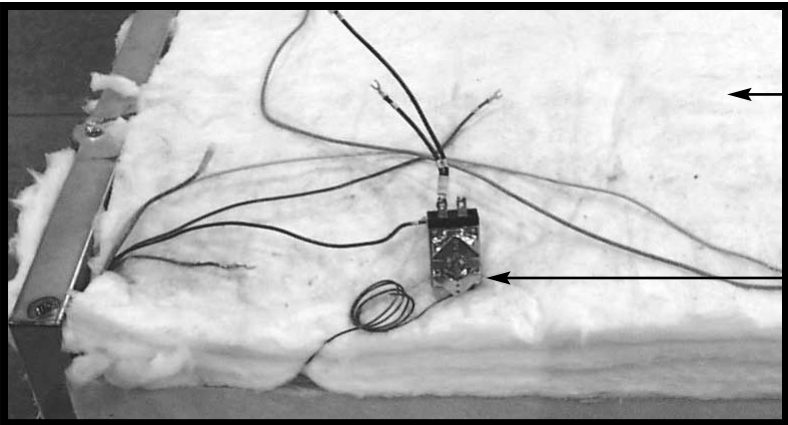
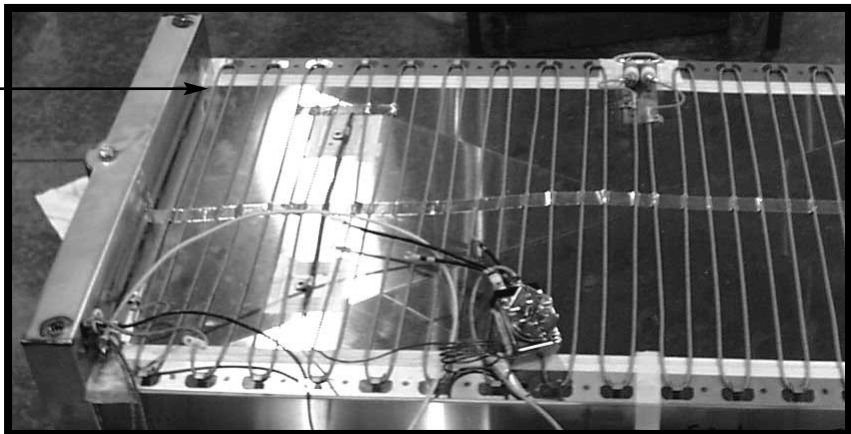

Insulation

Thermostat

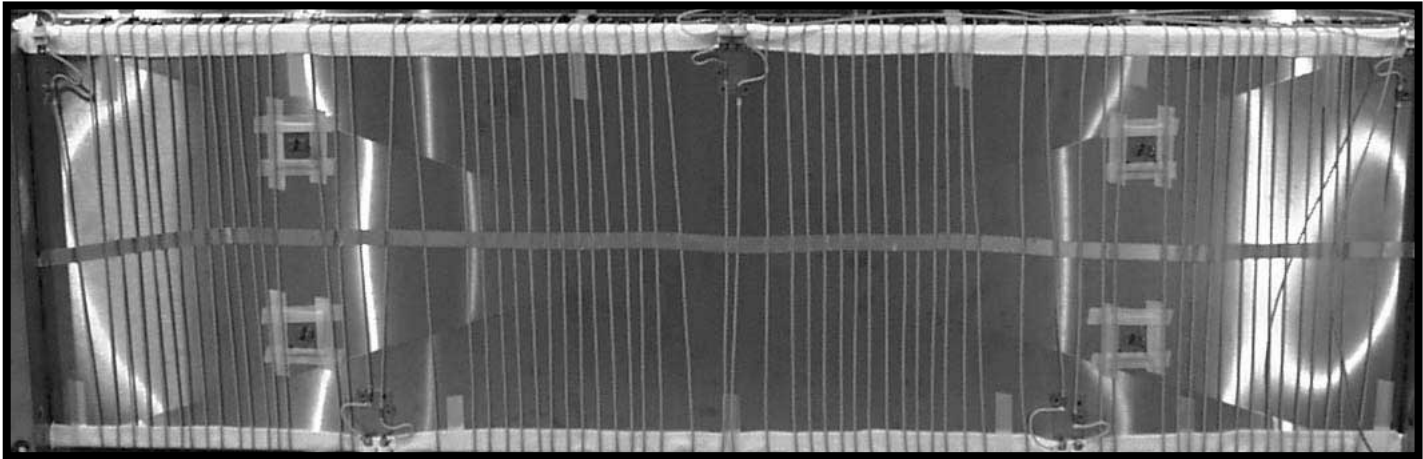

Cable Heat Element Wrap

AT NO TIME SHOULD THIS UNIT
BE STEAM CLEANED,
WASHED DOWN,
FLOODED WITH WATER
OR LIQUID SOLUTION.

Severe damage or
electrical hazard
could result.



SAFETY ALERT

This units performance has been optimized using the factory provided bulb. These bulbs should be replaced with an exact replacement or with a factory recommended replacement. These bulbs have been treated to resist breakage and must be replaced with similarly treated bulbs in order to maintain compliance with NSF standards.



MAKE CERTAIN THE UNIT IS
DISCONNECTED FROM
THE POWER SOURCE BEFORE
CLEANING OR SERVICING



100-TMC
base heated carving shelf

SERVICE VIEW 100-TMC CARVING STATION

11/12/97	PART DESCRIPTION	QTY PER UNIT	ALTO-SHAAM PART NUMBER
	1. BOTTOM	1	1973
	2. BOTTOM MOUNTING SCREWS	22	SC-2459
	3. INSULATION: 17" x 22" (432mm x 559mm)	1	IN-2381
	4. HEATING ELEMENT CLAMP	1	1070
	5. THERMOSTAT CAPILLARY BULB	1	—
	6. PARCHMENT PAPER: 6" X 23" (152mm X 584mm)	1	IN-3043
	7. HEATING CABLE ELEMENT	1	CB-3503
	8. CABLE CONNECTOR, LARGE	1	CR-3067
	9. CABLE CONNECTOR, SMALL	1	CR-3066
	10. CONTROL PLATE	1	11570
	11. CONTROL PLATE MOUNTING SCREWS	4	SC-2459
	12. THERMOSTAT	1	TT-3498
	THERMOSTAT KNOB	1	KN-3473
	13. INDICATOR LIGHT, 125V	1	LI-3027
	INDICATOR LIGHT, 230V	1	LI-3951
	14. LIGHT AND POWER SWITCH	2	SW-3409
	15. CORD: Length 3' (914mm)	1	CD-3031
	CORDSET, 230V	1	CD-3922
	16. PLUG	1	PG-3478
	17. LAMP BLOCK BOTTOM COVER	2	1221
	18. LAMP BLOCK COVER MOUNTING SCREWS	4	SC-2459
	19. CONNECTIONS	4	CR-3066
	20. LAMP MOUNTING BLOCK	2	BK-2668
	21. LAMP MOUNTING BLOCK BRACKETS	2	1223
	22. LAMP MOUNTING BLOCK MTG. SCREWS	8	SC-2425
	23. LAMP ASSEMBLY	2	LP-3525
	24. LAMP, 125V	2	LP-3016
	LAMP, 230V	2	LP-3319
	25. CUTTING BOARD	1	BA-2358
	26. TOP ASSEMBLY	1	4977

100-TMC Service View

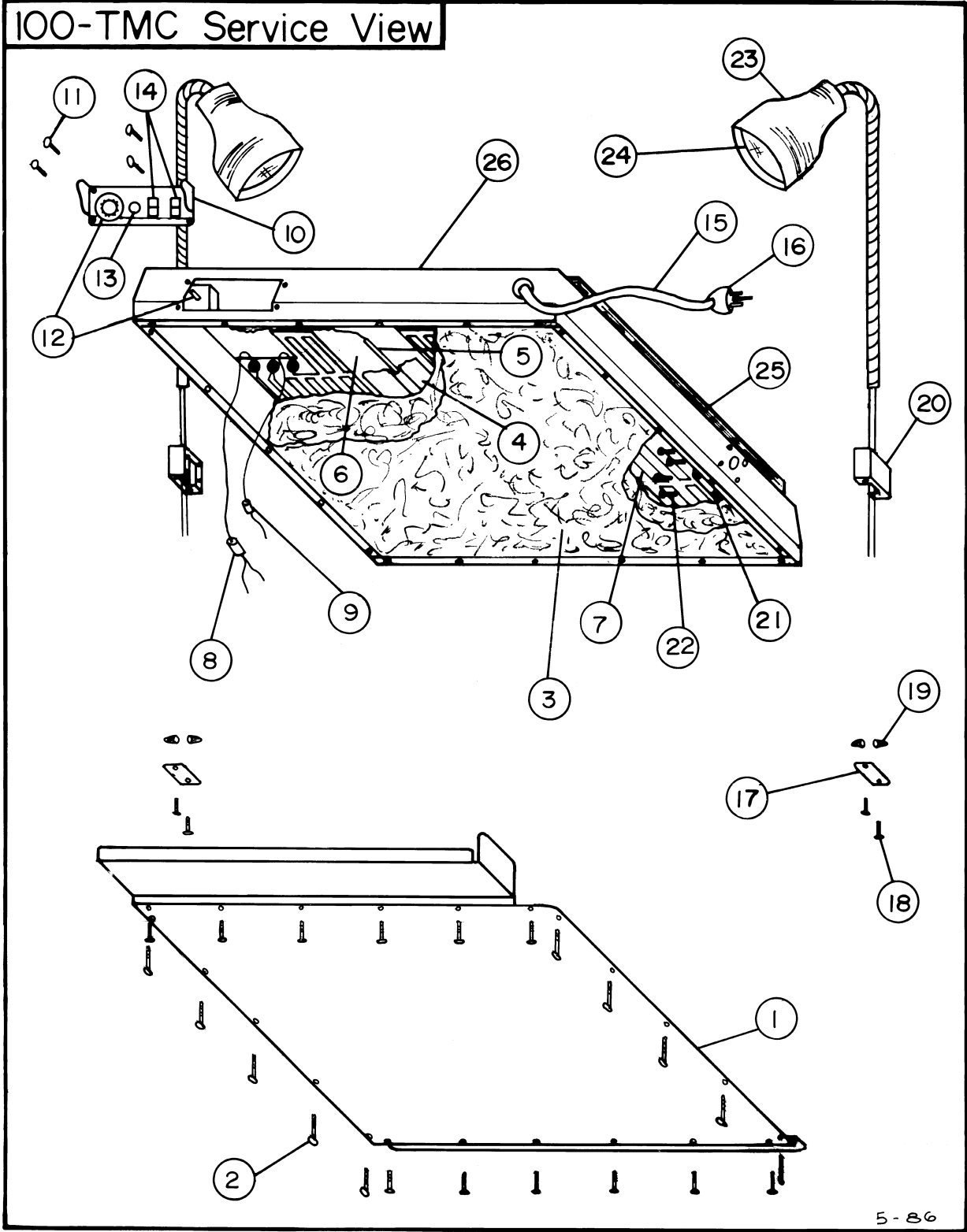

125V 1000W
100-TMC
WIRING DIAGRAM
A-7267

125V 1000W
100-TMC
WIRING DIAGRAM
A-7267

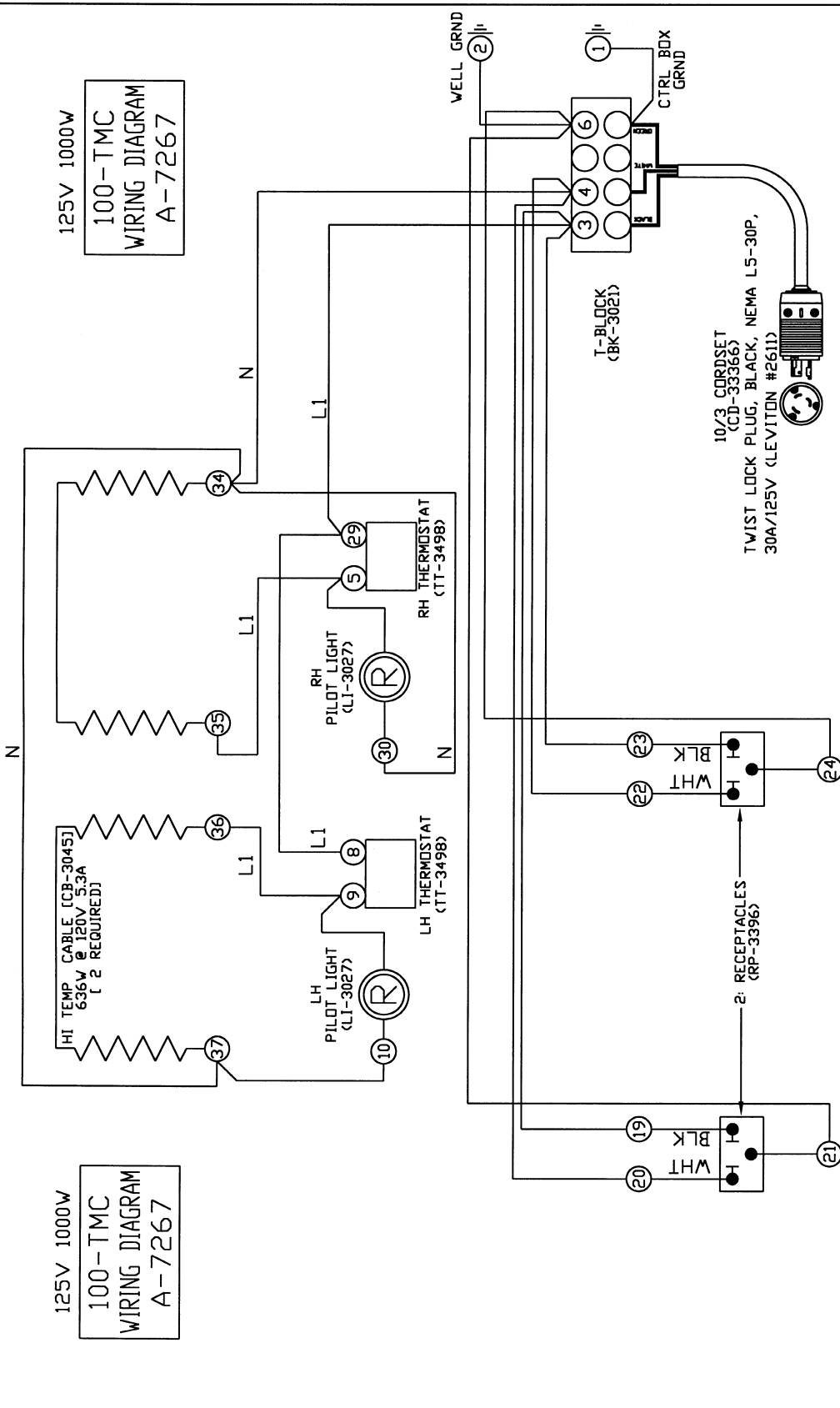

WIRE-DIAGRAM

MODELS: 300-TMC/2001/120V

ALTO-SHAAM
MENOMONEE FALLS, WISC. 53052-450

SCALE: 3/4" = 1"
BY: MS DATE: 5-14-01

DWG: 7266-120V-2001
A-7266-120V-2001

120V - 60Hz
1272W, 10.6A (STATION ONLY)
2272W, 18.9A (W/ 1:100-TMC)
3272W, 27.2A (W/ 2:100-TMC)

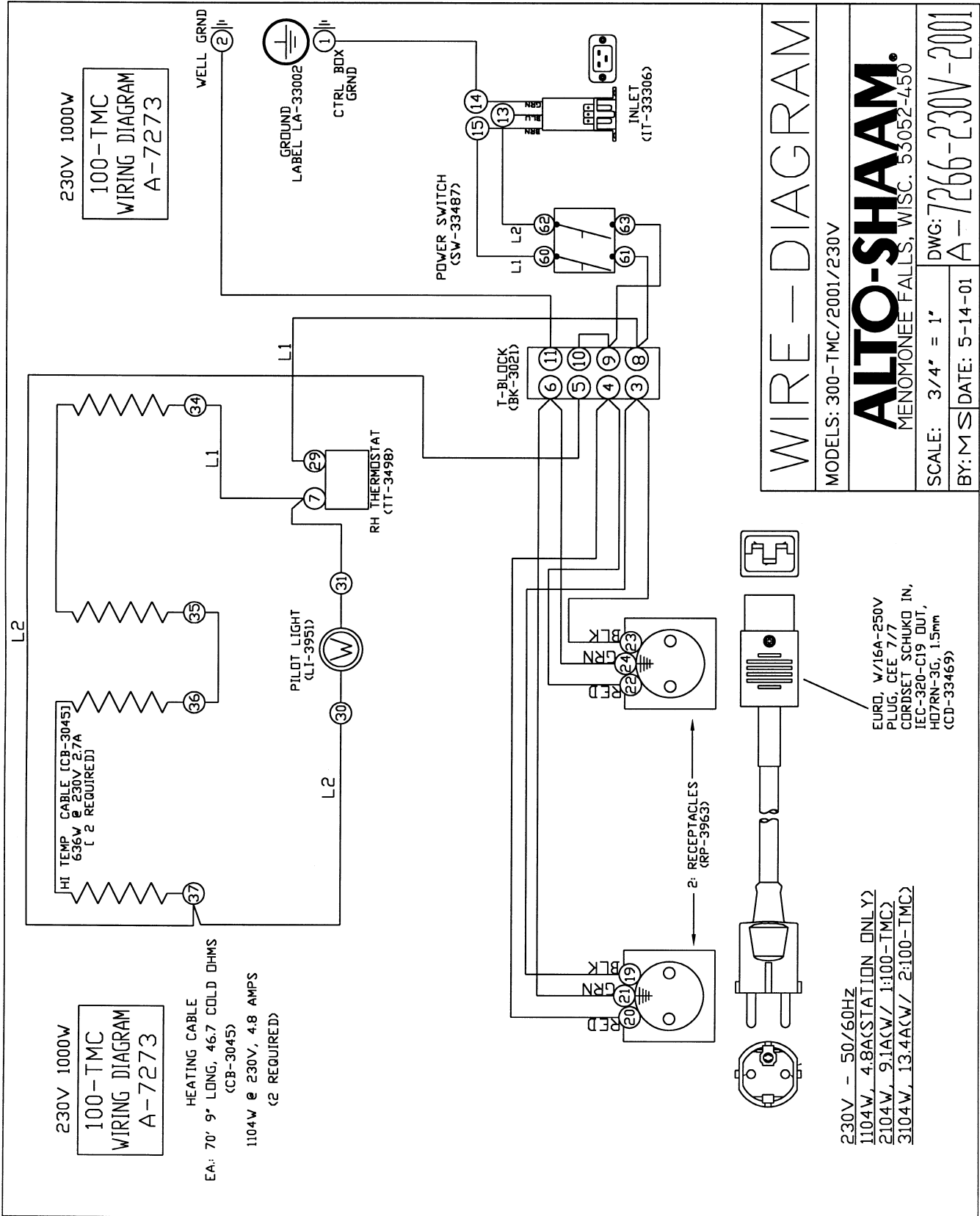

WIRE-DIAGRAM

MODELS: 300-TMC/2001/230V

ALTO-SHAAM.
MENOMONEE FALLS, WISC. 53052-450

SCALE: 3/4" = 1"

BY: M S DATE: 5-14-01

DWG: 7266-230V-2001
A-7266-230V-2001

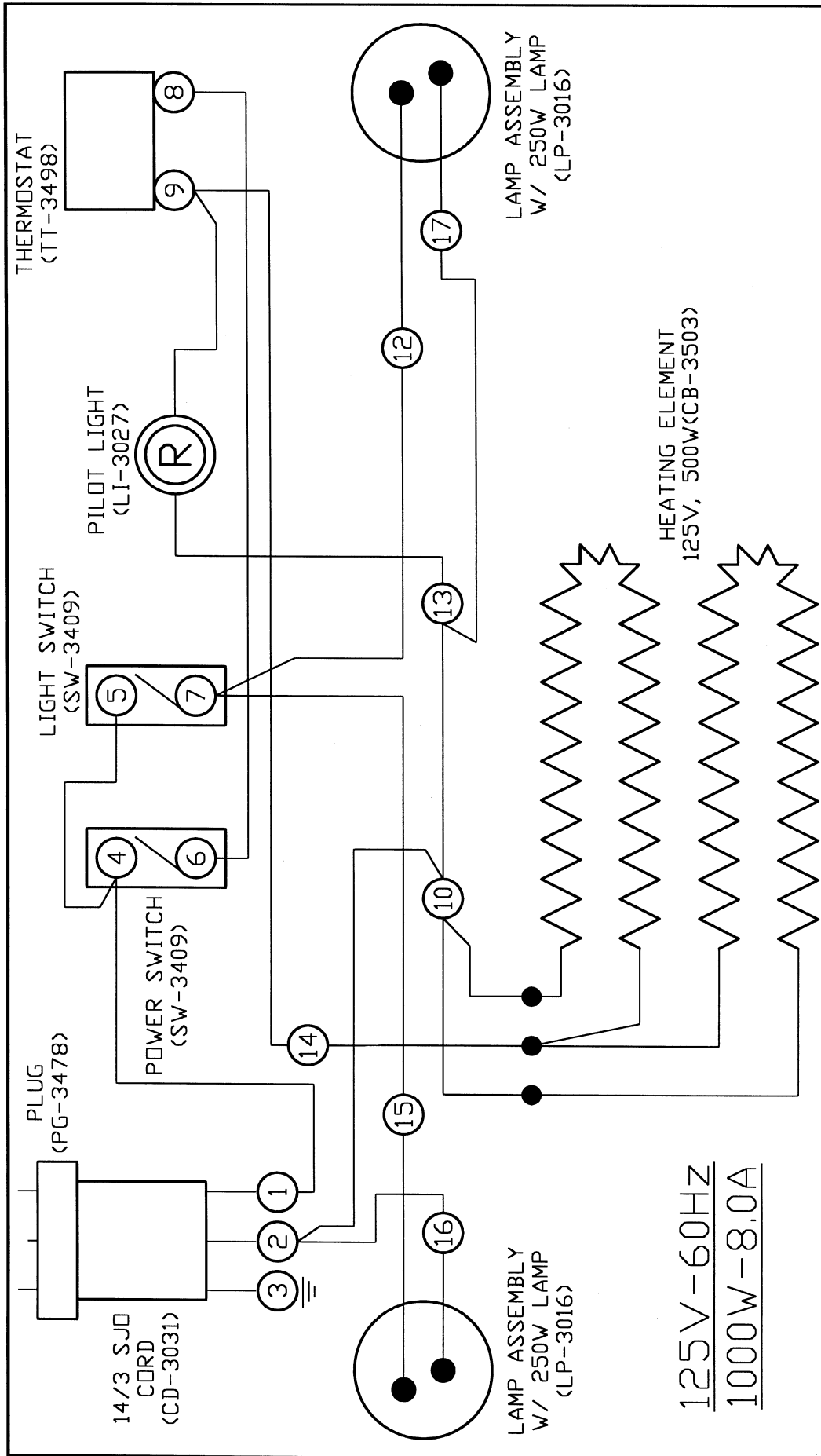

LAMP ASSEMBLY
W/ 250W LAMP
(LP-3016)

HEATING ELEMENT
125V, 500W(CB-3503)

125V-60HZ
1000W-8.0A

LAMP ASSEMBLY
W/ 250W LAMP
(LP-3016)

100-TMC		(125V)	
REV. NO.	DATE	BY	
1	11/25/97	RS	
2			
3			
4			
5			

WIRING DIAGRAM

ALTO-SHAAM INC.
MENDONNEE FALLS, WISCONSIN

DRAWN BY	ALD	SCALE	1"=1'	DWG. NO.	
APP'D	MSM	DATE	4-10-86		A-7267

NOTE #1: ALL NUMBERS IN () = ALTO-SHAAM PART NUMBERS

NOTE #2: SEE DRW. #B-8549 FOR WIRE ASSEMBLIES

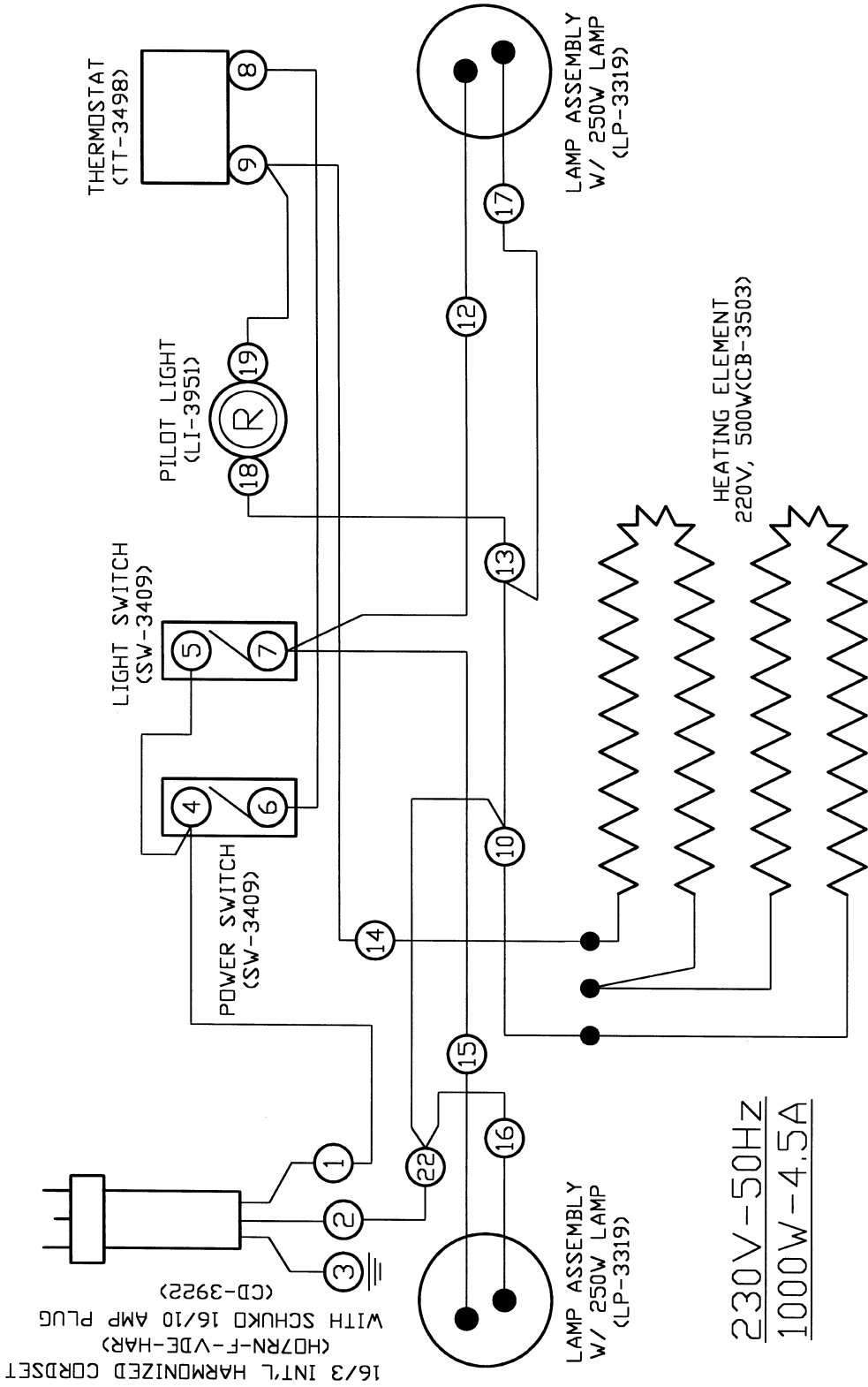

REVISIONS		100-TMC		(230V)	
NO.	DATE	BY			
1	11/25/97	RS	WIRING DIAGRAM		
2			ALTO-SHAAM INC. MENDONNEE FALLS, WISCONSIN		
3			DRAWN BY ALD SCALE 1"=1' DWG. NO.		
4			APP'D MSM DATE 5-14-86 A-7273		
5					

NOTE #1: ALL NUMBERS IN () = ALTO-SHAAM PART NUMBERS

NOTE #2: SEE DRW. #B-8555 FOR WIRE ASSEMBLIES

TRANSPORTATION DAMAGE and CLAIMS

ALTO-SHAAM[®] LIMITED WARRANTY



All Alto-Shaam equipment is sold F.O.B. shipping point, and when accepted by the carrier, such shipments become the property of the consignee.

Should damage occur in shipment, it is a matter between the carrier and the consignee. In such cases, the carrier is assumed to be responsible for the safe delivery of the merchandise, unless negligence can be established on the part of the shipper.

1. Make an immediate inspection while the equipment is still in the truck or immediately after it is moved to the receiving area. Do not wait until after the material is moved to a storage area.
2. Do not sign a delivery receipt or a freight bill until you have made a proper count and inspection of all merchandise received.
3. Note all damage to packages directly on the carrier's delivery receipt.
4. Make certain the driver signs this receipt. If he refuses to sign, make a notation of this refusal on the receipt.
5. If the driver refuses to allow inspection, write the following on the delivery receipt:
Driver refuses to allow inspection of containers for visible damage.
6. Telephone the carrier's office immediately upon finding damage, and request an inspection. Mail a written confirmation of the time, date, and the person called.
7. Save any packages and packing material for further inspection by the carrier.
8. Promptly file a written claim with the carrier and attach *copies* of all supporting paperwork.

We will continue our policy of assisting our customers in collecting claims which have been properly filed and actively pursued. We cannot, however, file any damage claims for you, assume the responsibility of any claims, or accept deductions in payment for such claims.

Alto-Shaam, Inc. warrants to the original purchaser that any original part that is found to be defective in material or workmanship will, at our option, subject to provisions hereinafter stated, be replaced with a new or rebuilt part.

The labor warranty remains in effect one (1) year from installation or fifteen (15) months from the shipping date, whichever occurs first.

The parts warranty remains in effect one (1) year from installation or fifteen (15) months from the shipping date, whichever occurs first.

Exceptions to the one year part warranty period are as listed:

- A. Halo Heat cook/hold ovens include a five (5) year parts warranty on the heating element. Labor will be covered under the terms of the standard warranty period of one (1) year or fifteen (15) months.
- B. Alto-Shaam Quickchillers include a five (5) year parts warranty on the refrigeration compressor. Labor will be covered under the terms of the standard warranty period of one (1) year or fifteen (15) months.

This warranty does not apply to:

1. Calibration
2. Replacement of light bulbs and/or the replacement of display case glass due to damage of any kind.
3. Equipment damage caused by accident, shipping, improper installation or alteration.
4. Equipment used under conditions of abuse, misuse, carelessness or abnormal conditions.
5. Any losses or damage resulting from malfunction, including loss of product or consequential or incidental damages of any kind.
6. Equipment modified in any manner from original model, substitution of parts other than factory authorized parts, removal of any parts including legs, or addition of any parts.

This warranty is exclusive and is in lieu of all other warranties, expressed or implied, including the implied warranties of merchantability and fitness for purpose. In no event shall the Company be liable for loss of use, loss of revenue, or loss of product or profit, or for indirect or consequential damages. This warranty is in lieu of all other warranties expressed or implied and Alto-Shaam, Inc. neither assumes or authorizes any persons to assume for it any other obligation or liability in connection with Alto-Shaam equipment.

ALTO-SHAAM, INC.

Warranty effective January 1, 2000

Record the model and serial numbers of the unit for easy reference. Always refer to both model and serial numbers in your correspondence regarding the unit.

Model: _____
Serial Number: _____
Purchased From: _____
Date Installed: _____ Voltage: _____

HALO HEAT COOK/HOLD/SERVE SYSTEMS BY ALTO-SHAAM.

W164 N9221 Water Street • P.O. Box 450 • Menomonee Falls, Wisconsin 53052-0450 • U.S.A.

PHONE: 262.251.3800

FAX: 262.251.7067 • 800.329.8744 U.S.A./CANADA

WEBSITE:

800.558.8744 U.S.A./CANADA

262.251.1907 INTERNATIONAL

www.alto-shaam.com

PRINTED IN U.S.A.