

COMBITHERM[®]

COMBINATION OVEN/STEAMER

INSTALLATION and MAINTENANCE



Model 20•20 ELECTRIC *ELECTRONIC CONTROL*

ALTO SHAAM[®]

W164 N9221 Water Street • P.O. Box 450 • Menomonee Falls, Wisconsin 53052-0450 • U.S.A.

PHONE: (262)251-3800 (800)558-8744 U.S.A./CANADA • FAX: (262)251-7067 (800)329-8744 U.S.A. (262)251-1907 INTERNATIONAL • www.alto-shaam.com

PRINTED IN U.S.A.

20•20EC • 2001

Installation

Transportation	1
Installation Site	1
Electrical Installation	2
Sound Absorber	2
Water Drainage	3
Water Supply	3
Installation Checklist	4
Installation Data	5
Installation Dimensions	5
Accessories	5
Safety and Operational Precautions	6

Cleaning and Maintenance

Daily Gasket Cleaning	6
Probe Usage & Cleaning	6
Roll-In Cart/Food Trolley Cleaning	6
Oven Cleaning	7
Steam Generator Flush	8
Decalcification	8
Preventive Maintenance	9

Trouble Shooting Checklist

Water Trouble	10
Steam Trouble	10
Motor Trouble	12
Condenser Trouble	12
Convection Trouble	13
General Trouble	13

Service and Parts

Replacement Parts List	15
System Diagram	16
Wiring Schematic, 208-240V	17
Wiring Diagram, 208-240V	18
Wiring Schematic, 440-480V	19
Wiring Diagram, 440-480V	20
Transportation Damage and Claims	
Limited Warranty	

COMBITHERM® INSTALLATION and SPECIFICATIONS

TRANSPORTATION

Upon receipt of the Combitherm Combination Oven-Steamer, check the exterior of the shipping crate for any physical damage that could result in damage to the contents. If the oven was not received from the carrier in an upright position, there is a stronger possibility of concealed damage. Uncrate the unit carefully and inspect for any transit damage. Immediately report any damage to the delivering freight carrier.

The oven must remain on the pallet while being moved to the installation site by fork-lift or pallet lift truck.



When removing the oven from the pallet to the installation site, do not lift at the condenser housing. Care should also be used to prevent damage to the drip-tray hanger permanently mounted at the bottom of the oven door.

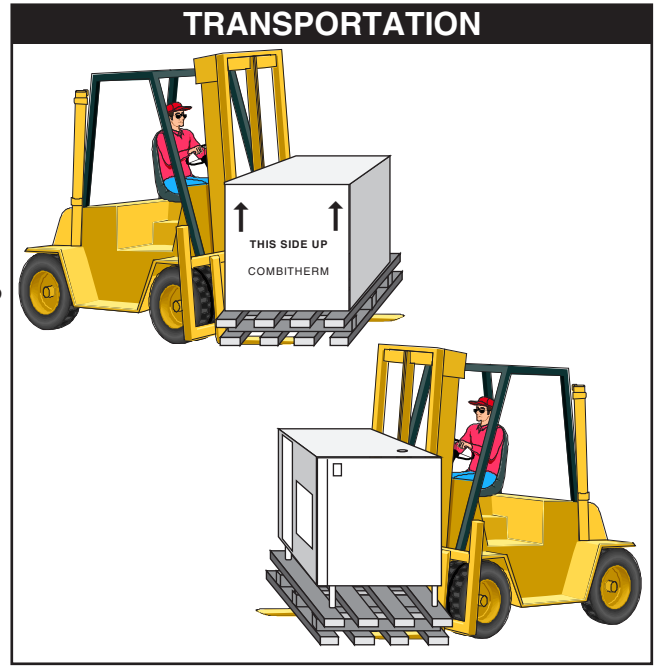

INSTALLATION SITE

HOOD INSTALLATION IS REQUIRED

In order to ensure proper ventilation, a minimum distance of at least 6" (152mm) must be kept from the control panel side [left] of the oven and any adjoining surfaces. *In order to provide sufficient clearance for service, 20 inches (508mm) must be allowed on the left-hand side of the unit.* If this clearance can not be provided, it will be necessary to disconnect the gas, water and drain connection in order to move the oven via a lift truck to gain access for servicing, and this will not be covered by warranty.

Allow a minimum of 3-1/2" to 5" (89mm to 127mm) from the right side of the oven to allow the door to open to at least a 90° angle. Fully opened, the door will extend up to a 225° angle.

Allow a minimum clearance of 5" (127mm) from the back of the oven for plumbing connections.

Allow adequate clearance for the steam vent(s) located at the top [right-rear] of the oven.

Do not install the oven adjacent to heat producing equipment such as fryers, broilers, etc. Minimum clearance recommended: 20" (50cm).

Adjust the Combitherm Oven to **LEVEL** on a stable, horizontal surface by means of the height-adjustable legs.

ALL INSTALLATION INSTRUCTIONS AND REQUIREMENTS MUST BE STRICTLY OBSERVED.



IMPROPER CONNECTION OF THIS APPLIANCE NULLIFIES ALL WARRANTIES.

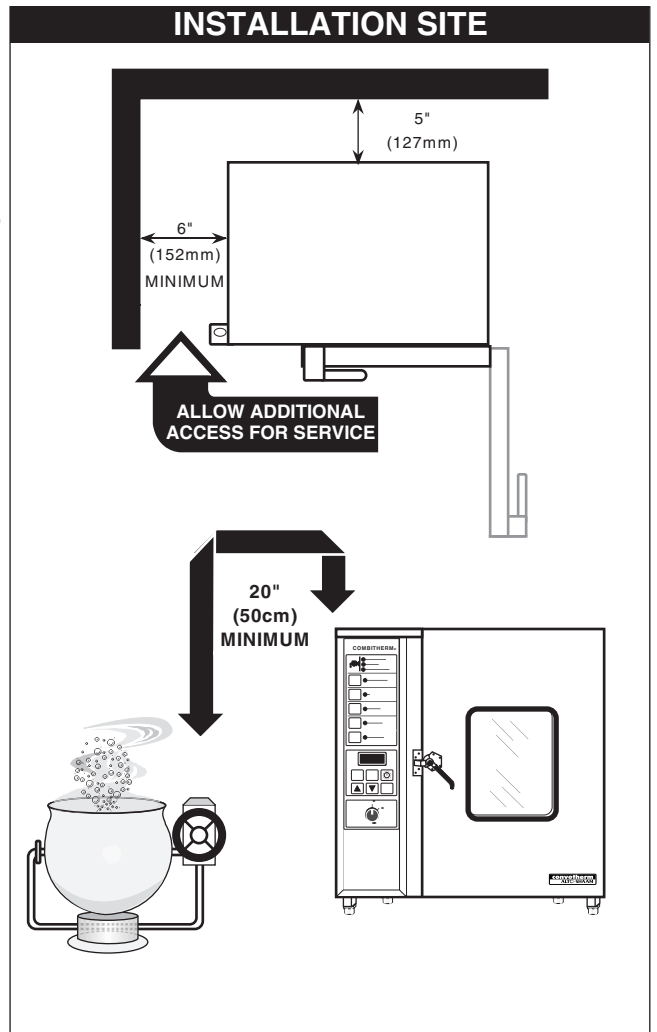

COMBITHERM® INSTALLATION and SPECIFICATIONS

ELECTRICAL INSTALLATION

An electrical wiring diagram is located behind the control panel on the left side of the oven. The oven must be installed by a qualified electrician. This appliance must be branch circuit protected with proper ampacities, in accordance with the wiring diagram located in the electrical compartment of the oven. The oven must be properly grounded in accordance with the National Electrical Code and applicable local codes.

CAUTION

ENSURE THE AVAILABLE
POWER SOURCE MATCHES
THE VOLTAGE STAMPED
ON THE NAMEPLATE OF
THE OVEN.

For supply connections, use the wire size posted on the label located behind the left hand side panel.

Each oven motor displays an arrow showing the direction of the motor rotation.

ELECTRICAL INSTALLATION

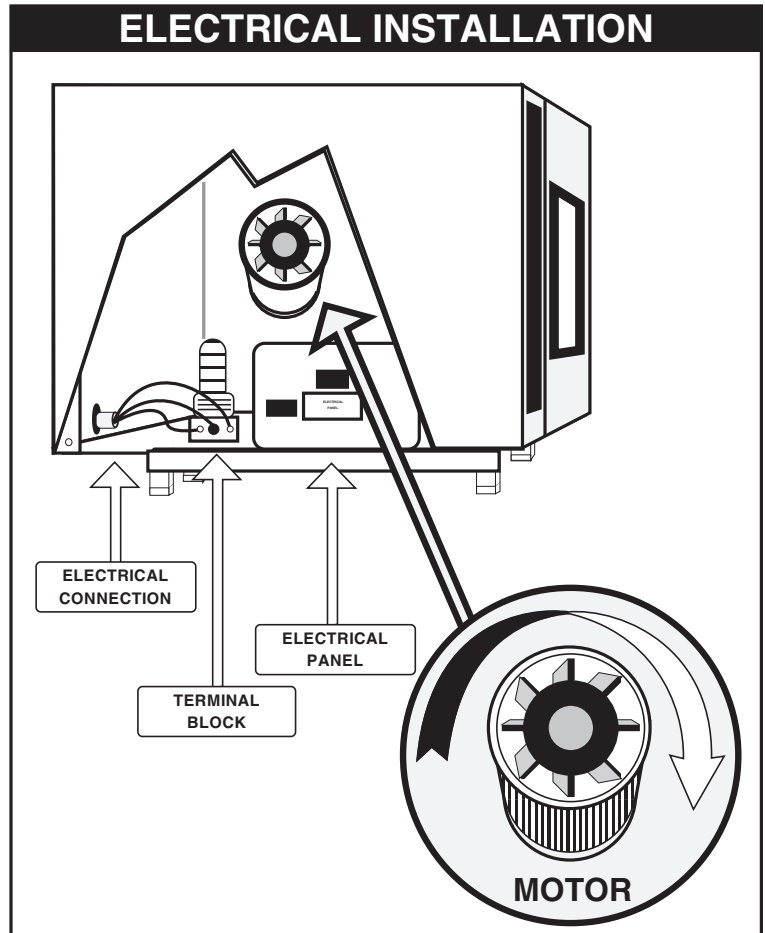

FOLLOWING ELECTRICAL CONNECTION,
THE FAN ***MUST*** ROTATE IN THE SAME
DIRECTION AS THE ARROW
LOCATED ON THE OVEN FAN
MOTOR.

CAUTION

THIS APPLIANCE ***WILL NOT*** FUNCTION
PROPERLY AND DAMAGE CAN OCCUR IF
THE MOTOR ROTATION IS NOT CORRECT.

TO CHANGE MOTOR DIRECTION, EXCHANGE
TWO OF THE INCOMING PHASES.

COMBITHERM® INSTALLATION and SPECIFICATIONS

WATER DRAINAGE

The oven must discharge through an indirect waste pipe by means of an air gap. The drain thread is 1-1/4" NPT.

A union is required. Install a 1-1/4" (32mm) diameter drain line with a maximum length of 12" (305mm) and a 3 to 5 percent gradient.

ATTENTION: In the U.S.A., this equipment is to be installed to comply with the Basic Plumbing Code of the Building Officials and Code Administrators International, Inc. [BOCA], and the Food Service Sanitation Manual of the Food & Drug Administration [FDA]

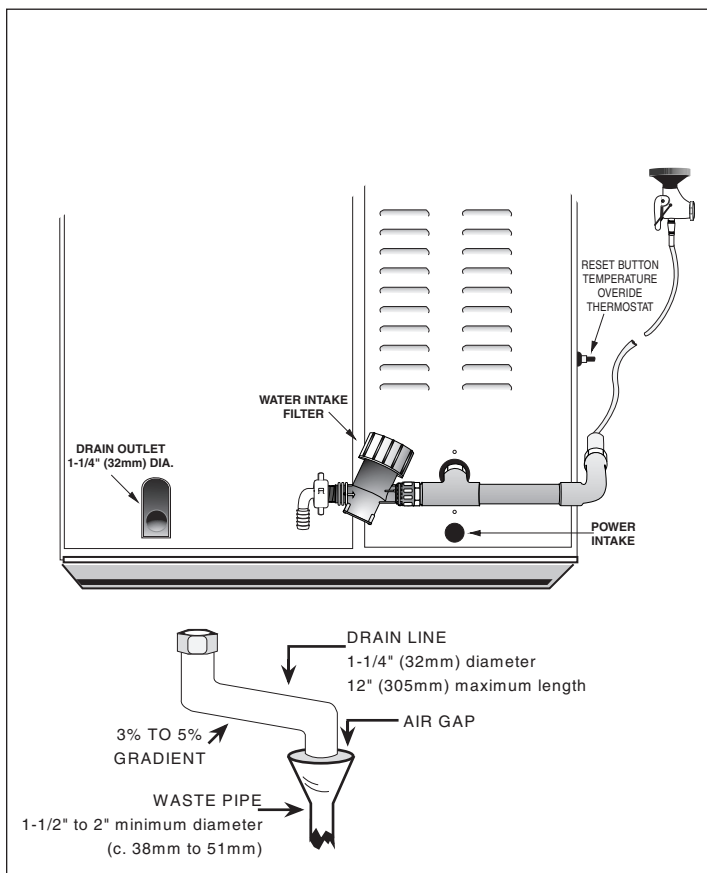

WATER SUPPLY

CONNECT TO POTABLE (*DRINKABLE*) COLD WATER ONLY

**WATER PRESSURE REQUIREMENTS: MINIMUM 45 PSI (3 BAR)
MAXIMUM 75 PSI (5 BAR)**

A shut-off valve and approved back-flow preventer must be installed when connecting the oven to the cold water intake. Connecting pipe thread is 3/4" NPT.

A hose connector ([HO-22116](#)) is supplied for flexible hose connection to the cold water source.

PIPE SEALING TAPE (TEFLON) MUST BE USED AT ALL CONNECTION POINTS. The use of a pipe sealing compound is not recommended.

The shut-off valve must be in the OPEN position when the oven is being used.

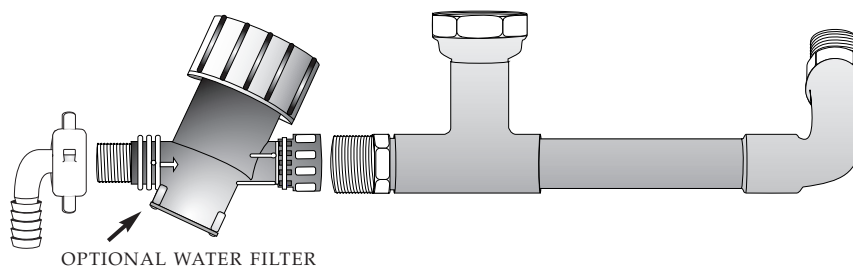
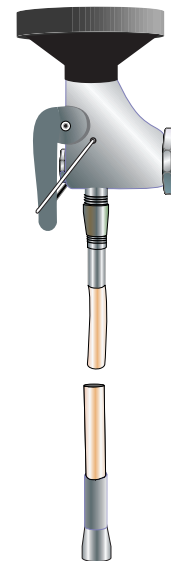

COMBITHERM® INSTALLATION and SPECIFICATIONS

IMMEDIATELY FOLLOWING INSTALLATION:

BEFORE SWITCHING POWER SWITCH "ON"

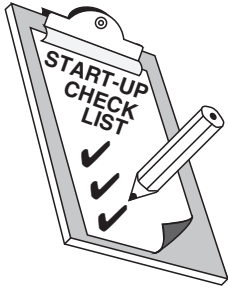





- ✓ Make certain Power Switch is in the "OFF" position.
- ✓ Make certain all unnecessary articles are removed from the oven interior.
- ✓ Turn the water supply "ON" and make certain the connections do not leak.
- ✓ Flood the interior oven compartment floor with water from hand-held hose and check to make certain the drain connections do not leak.
- ✓ Make certain the fan guard cover plate is in place and secure.
- ✓ Make certain the electrical connections are correct and sound.

IF ALL IS IN ORDER ...

WITH DOOR CLOSED, TURN POWER SWITCH "ON"

1. Press the STEAM  program key to automatically fill the steam generator and heat the water to stand-by mode temperature of 150°F (65°C).
 - The STEAM program LED light will illuminate.
 - The LOW-WATER LED light will illuminate and flash until the steam generator has been filled.
 - The STEAM LED light will illuminate and flash until the water temperature has reached the stand-by mode temperature of 150°F (65°C).
 - When the STEAM LED light stops flashing, the oven is ready for immediate operation in the STEAM mode or the selection of any other program mode.

2. Push SUPERHEATED STEAM AND CONVECTION  program key. Press COOK TEMP  and use  and  to set the temperature to 250°F (120°C). Press and hold TIMER  key for continuous ON time until "---" appears in the display .

Press START  key to verify proper program operation.

- The STEAM LED will illuminate periodically whenever the oven is producing steam.
- The CONVECTION LED will illuminate periodically whenever the oven is producing convection heat.
- The FAN LED will be illuminated throughout the entire cooking process.

Carefully open oven door, observing steam caution.

— Indicator lights for FAN and STEAM should go "OUT."

Close the door and press STOP  key to end program check.

3. Push CONVECTION  program key. Press COOK TEMP  and use  and  to set the temperature to 250°F (120°C). Press and hold TIMER  key for continuous ON time until "---" appears in the display .

Press START  key to verify proper program operation.

- The CONVECTION LED will illuminate periodically whenever the oven is producing heat.
- The FAN LED will be illuminated throughout the entire cooking process.

Carefully open oven door, observing steam caution.

— Indicator lights for FAN and CONVECTION should go "OUT."

Close the door and press STOP  key to end program check.

4. TURN POWER "OFF."

THE OVEN IS NOW READY FOR NORMAL OPERATION.



STEAM!

For safe release of the cooking compartment steam, initially open the door approximately 2" (50mm) only. Stand behind the door as the hot steam is released.

COMBITHERM® INSTALLATION and SPECIFICATIONS

Model	20•20	
Installation Data		
Type of unit	Floor standing	
Pan capacity *Additional wire shelves required for maximum capacity	40 Full-size pans (20" x 12" x 2-1/2") 20 Full-size sheet pans* (18" x 26" x 1")	
Side rack spacing	2-5/8" (67mm)	
Oven chamber width	26-1/4" (667mm)	
Oven chamber depth	32-11/16" (830mm)	
Oven chamber height	60-1/4" (1530mm)	
Net weight	958 lb (435 kg)	
Electrical specs		
208/240V — 50/60 Hz, 3 ph	At 208V	At 240V
Power connection	54.3 kW	72.4 kW
Current (Amps/phase)	150.9	174.4
Terminal Block connection	3 Wire Plus Ground AWG 4 or larger	
440/480V — 50/60 Hz, 3 ph	At 440V	At 480V
Power connection	60.8 kW	72.4 kW
Current (Amps/phase)	80.0	87.2
Terminal Block connection	3 Wire Plus Ground AWG 2 or larger	
Noise level	44 dB(A)	
Construction	Stainless Steel Type 304 Interior 20 gauge Exterior 20 gauge	
Insulation	1-5/8" (40mm) thick	
Hose length hand shower	86-5/8" (2200mm)	
Cold water intake	3/4" NPT	
Water pressure (Flowing pressure)	45 to 75 psi (3 to 5 bar)	
Drain connection	1-1/4" NPT	

Accessories	
Chicken Roasting Rack	
— 6 chicken capacity (fits full-size pan)	SH-23000
— 8 chicken capacity (fits full-size pan)	SH-23619
— 10 chicken capacity (fits in side racks)	SH-22634
Grease Tray WITH DRAIN (1-1/2" [38mm] DEEP)	4758
Grease Tray WITH DRAIN (2-3/4" [70mm] DEEP)	14475
Oven Cleaner	CE-24750
Specially formulated for Combitherm Ovens Twelve (12) containers/case, 1 quart (c. 1 liter) each	
Preheat Sealing Strip	
➤ FOR USE IN PLACE OF ROLL-IN CART WHILE PREHEATING	14568
Roll-In Cart	
➤ INTERCHANGEABLE WITH 20•20W & QC-100	5815
Shelves, Stainless Steel Wire	SH-22473
Water Conditioner Kit (includes 1 filter cartridge)	FI-23014
Water Conditioner Cartridge	FI-23017

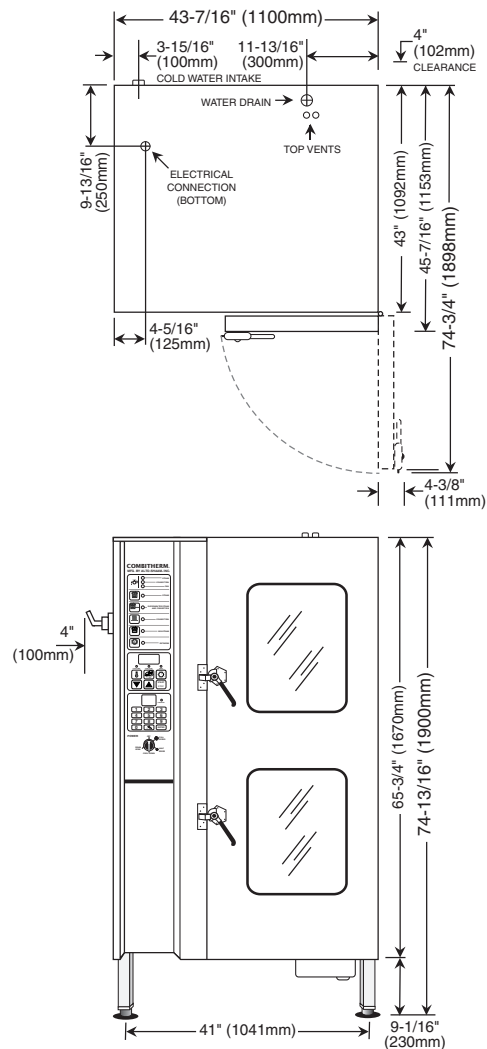

Safety and Operational Precautions:



- Before opening the oven door during normal operation, always press the STOP key and wait a few seconds to allow the fan to stop rotating.
- Before using the hand sprayer, wait until the cooking compartment has cooled down to at least 130°F (54°C).
- When using the hand sprayer, make certain the power switch is in the OFF position.
- *Never* use the oven cleaner or the hand sprayer to clean the outer surface of the oven.
- Flush the steam generator, clean the oven and oven gasket on a daily basis.
- To avoid unnecessary heat loss and the possibility of overheating the convection heating elements, **NEVER** preheat the model 20•20 WITHOUT A ROLL-IN CART (TROLLEY) or a PREHEAT SEALING STRIP. **NEVER** allow this model to remain in the stand-by mode for prolonged periods WITHOUT A ROLL-IN CART (TROLLEY) or a PREHEAT SEALING STRIP.

COMBITHERM® CLEANING and MAINTENANCE



Establishing a routine cleaning and maintenance schedule will help keep the oven running at top operating efficiency and is an absolutely essential part of a comprehensive sanitation program. *Good equipment maintained and kept clean works better and lasts longer.* **PROTECT YOUR INVESTMENT.**

Daily Oven Cleaning

To be performed at the end of each production day or between production shifts.

Daily Steam Generator Flush

When operating the oven on a regular basis, the steam generator must be flushed once a day. This procedure will prevent lime deposits and scale build-up from forming in the steam generator.

Weekly Steam Generator Back-Flush

Back-flushing the oven on a weekly basis prevents lime deposits and scale build-up from forming in the entire steam generating system. It will flush the areas missed with the daily steam generator flushing procedure. This procedure should be followed once a week, in place of the daily steam generator flush.

Monthly Decalcification

It is VERY important to decalcify the oven, particularly in areas with extremely hard water. This procedure should be followed once a month, in place of the daily steam generator flush.

Daily Gasket Cleaning

It is important to prolong the life of the oven gasket by cleaning this item on a daily basis. Routine cleaning will help protect the composition of the gasket from deterioration caused by acidic foods. Remove pull-out gasket and wash in hot soapy water or in the dishwasher. Always replace the gasket before cleaning the oven interior or operating the oven.



Probe Usage and Cleaning

After each use of the CORE TEMP program mode, wipe the probe tip with a clean paper towel to remove food debris. Follow by wiping the probe with a disposable alcohol pad. Return the probe to the proper door bracket position.

Probe Cleaning Procedures

1. Remove all food soil from probe between loads and at the end of each production shift. Wipe entire probe, cable assembly, and probe holding door bracket with warm detergent solution and a clean cloth.
2. Remove detergent by wiping the probe, cable, and bracket with clean rinse water and a cloth.
3. Wipe probe and probe bracket with disposable alcohol pad or sanitizing solution recommended for food contact surfaces.
4. Allow probe and cable to air dry in probe holding door bracket.
5. Rewipe the probe with a disposable alcohol pad prior to inserting in a new food product.

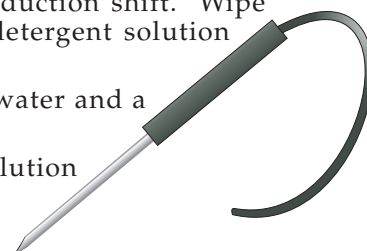

Roll-In Cart/Food Trolley Cleaning

1. Remove food trolley to a cart wash area. Trolleys may be cleaned using any mild cleaning detergent and warm water.
2. Hand wipe all framing, slides, drip pan, and base. Thoroughly clean debris from the casters. A spray hose can be used for easier cart cleaning.
3. Remove detergent solution with warm water.
4. Wipe or spray with a sanitizing solution designed for use on metal and vinyl food contact surfaces.
5. Allow trolley to air dry.

COMBITHERM® CLEANING and MAINTENANCE



RUBBER GLOVES AND PROTECTIVE EYE WEAR MUST BE WORN WHEN USING THE OVEN CLEANER. DO NOT MIX THE OVEN CLEANER WITH ANYTHING BUT WATER.



CAUTION

Causes severe burns. Do not get in eyes, on skin, or on clothing. Harmful or fatal if swallowed. Do not breathe mist. Use in well ventilated area. Keep out of reach of children.

USE AUTHORIZED COMBITHERM LIQUID OVEN CLEANER ONLY.

Unauthorized cleaning agents may discolor or harm interior surfaces of the oven. Read and understand label and material safety data sheet before using the oven cleaner.

THOROUGHLY RINSE EMPTY CONTAINER WITH WATER AND SAFELY DISCARD.

At no time should the exterior of the oven be steamed cleaned, hosed down with the hand-sprayer, flooded with water, or liquid solution.

Oven Cleaning



Clean the oven daily at the end of the production day or between production shifts.

USE THE AUTHORIZED COMBITHERM LIQUID OVEN CLEANER ONLY*

1. ▼ IF THE OVEN IS HOT:

Turn the Power Switch to the "OFF" position and allow the oven to cool to approximately 130°F (54°C). Leave the oven door open during the cooling process.

▼ IF THE OVEN IS COLD:

Turn the Power Switch to the "ON" position and preheat the oven in Superheated Steam or Convection at 130°F (54°C) for 10 minutes. After preheating, turn the Power Switch to the "OFF" position.

2. Wearing safety glasses and rubber gloves, generously spray the interior oven surfaces with an even coating of Combitherm Liquid Oven Cleaner. Spray all built in components and pans. Unfasten the Fan Guard Cover Plate, swing open and spray the back of the Fan Guard Cover Plate, convection element, the oven fan, along with the left-hand side of the oven.
3. If unit is equipped with the optional programmable control, securely close the oven door. Turn the Power Switch to the "ON" position, press the Cleaning Program Key and then press the Start Key. Steps 4 and 5 can then be bypassed.
4. Securely close the oven door and let the solution stand for a minimum of 10 minutes.
5. Turn the Power Switch to the "ON" position. Press the Steam program key and set the timer for ten minutes.

6. When the beeper signals the end of the cleaning process, press any Program key to deactivate the beeper. Turn the Power Switch to the "OFF" position and open the oven door.
7. Rinse the interior and all sprayed components with the hand-held hose. Make certain to thoroughly rinse all surfaces to remove any cleaning solution residue. Use a non-abrasive cleaning pad for any problem areas.
8. Use the hand held hose and direct a stream of water into the Steam By-Pass Port and into the oven drain to rinse away oven cleaner residue.
9. Replace the Fan Guard Cover Plate. Lock the cover into place and tighten thumb screws.

*COMBITHERM OVEN CLEANER

SPECIALLY FORMULATED FOR COMBITHERM OVEN CLEANING
TWELVE (12) CONTAINERS PER CASE
—1 QUART (C. 1 LITER) EACH ORDER ITEM: [CE-24750](#)

LEAVE DOOR SLIGHTLY OPEN AFTER CLEANING TO ALLEVIATE WEAR AND TEAR ON GASKET.

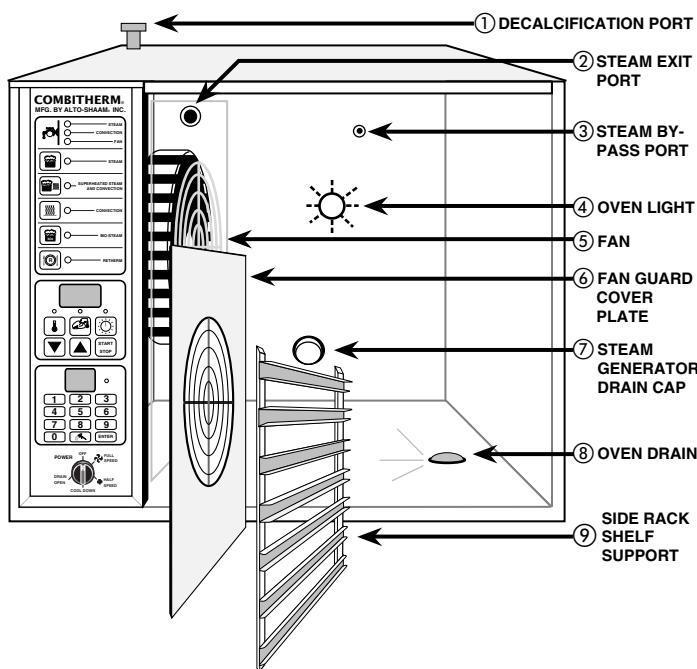

Steam Generator Flush

PERFORM DAILY

WITH THE OVEN AT ROOM TEMPERATURE



1. Turn the oven Power Switch to the "Drain Open" position. A buzzer will sound and water will begin to drain from the generator directly into the oven drain flushing accumulated deposits from the generator through the system.
2. Allow the water to continue to flow for a period of 30 seconds.
3. Remove the hand-held hose from the side of the oven and direct a stream of fresh water directly into the Steam Exit Port ②.
4. Leave the Power Switch in the "Drain Open" position and press the Steam  key. A new supply of fresh, cold water will begin to flow through the steam generator.
5. After a period of two minutes have lapsed, turn the Power Switch to the **OFF** position.

Decalcification

PERFORM ONCE A MONTH

in place of the daily steam generator flush.

WITH THE OVEN AT ROOM TEMPERATURE

1. Turn the power switch to the "Drain Open" position. A buzzer will sound and water will begin to drain from the generator directly into the oven drain, flushing accumulated deposits from the generator through the system. Allow the water to continue to flow for a period of 30 seconds.
2. Turn the Power Switch to the "OFF" position.
3. Using hand protection, open Decalcification Port ①. Use a funnel to pour one-half gallon (c. 2 liters) of distilled white vinegar into Decalcification Port ①. 
4. **Firmly screw the cover back on the Decalcification Port ① before proceeding** to avoid  extremely hot water from exiting the opening.
5. Turn the Power Switch to the Full Speed fan position and press the Steam program key. When the Steam LED light stops flashing, the oven is in stand-by mode. Allow the oven to remain in the stand-by mode for a minimum of 10 minutes.

DO NOT OPERATE ANY PROGRAM FUNCTION WITH VINEGAR IN THE STEAM GENERATOR SYSTEM.

6. Following the 10 minute stand-by period, the oven must be flushed to remove remaining deposits and vinegar solution from the steam generator.
7. Turn the oven Power Switch to the "Drain Open" position. A buzzer will sound and water will begin to drain from the generator directly into the oven drain to flush accumulated deposits and vinegar from the system.
8. Allow the water to continue to flow for a period of 30 seconds.
9. Remove the hand-held hose from the side of the oven and direct a stream of fresh water directly into the Steam Exit Port ②.
10. Leave the Power Switch in the "Drain Open" position and press the Steam  key. A new supply of fresh, cold water will begin to flow through the steam generator.
11. After a period of two minutes have lapsed, turn the Power Switch to the **OFF** position.

DURING DECALCIFICATION THE WATER FLOWING FROM THE DRAIN CAP IS EXTREMELY HOT!

- USE HAND PROTECTION WHENEVER TOUCHING THE STEAM GENERATOR DRAIN CAP.



- DO NOT TOUCH THE WATER FLOWING OUT OF THE STEAM GENERATOR DRAIN CAP OR STEAM GENERATOR DRAIN.



OVEN MUST BE AT ROOM TEMPERATURE

Preventive Maintenance

In addition to the routine maintenance procedures to prevent scale and lime build-up from forming in the steam generator system, there are several other steps to be taken for both sanitation purposes, and to keep the oven running at top operating efficiency. These additional safeguards will help prevent inconvenient down-time and costly repairs.

- **DO NOT DISPOSE OF GREASE, FAT, OR SOLID WASTE DOWN THE OVEN DRAIN.** Fats and solids will eventually coagulate in the drain system, causing blockage. Consequently, water will back-up into the condenser and interior oven compartment, resulting in an oven that is inoperable.

- **MAKE CERTAIN THE DRAIN SCREEN ⑦ IS ALWAYS IN PLACE. REMOVE ANY SOLID WASTE MATERIAL FROM THE DRAIN SCREEN BEFORE IT ENTERS THE DRAIN SYSTEM.** The routine removal of solids from the drain screen will help prevent blockage.

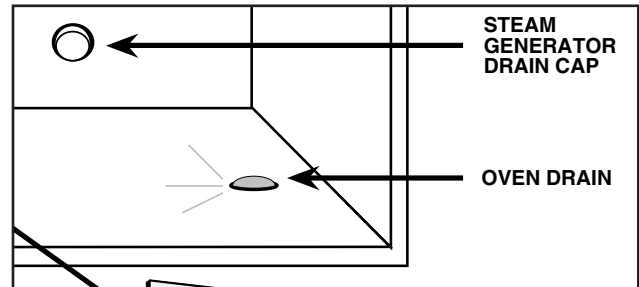

- **USE THE AUTHORIZED COMBITHERM OVEN CLEANER ONLY.**

The use of unauthorized cleaning agents may discolor or harm the interior surfaces of the oven.

- **TO PROLONG THE LIFE OF THE DOOR GASKET, REMOVE AND CLEAN THIS ITEM *DAILY*.** The acids and related compounds found in fat, particularly chicken fat, will weaken the composition of the gasket unless cleaned on a *daily basis*.

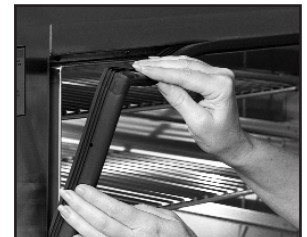

- **TO ADDITIONALLY PROTECT GASKET LIFE, ALLOW OVEN DOOR TO REMAIN SLIGHTLY OPEN AT THE END OF THE PRODUCTION DAY.**

An open door will relieve the pressure on the door gasket.

- **ROUTINELY CLEAN DOOR HINGES.** Open oven door to relieve tension. Clean all parts of the hinge.

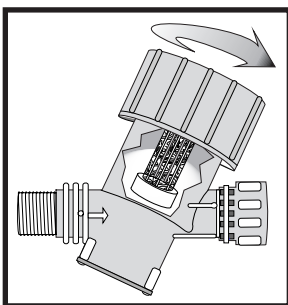

- **CLEAN WATER INTAKE SCREEN.** The routine removal of solids from the water intake screen will help prevent blockage. This should be done quarterly or more often depending on the amount of sediment in the water supply.

COMBITHERM® SERVICE and TROUBLE SHOOTING

TROUBLE SHOOTING CHECKLIST

PRIOR TO STARTING SERVICE WORK, OVEN MUST BE DISCONNECTED FROM THE POWER SOURCE.

PROBLEM	POSSIBLE CAUSE	REMEDY
WATER TROUBLE		
1. Low-Water LED light remains flashing.	a) Drain cap of steam generator in the interior of the oven compartment is open.	Hand-tighten drain cap.
	b) Seal of drain cap is leaking.	Replace seal.
	c) Water supply to unit is closed.	Open tap.
	d) Dirt is blocking strainer in water supply line.	Clean strainer.
	e) Dirt is blocking strainer in front of solenoid valve.	Clean strainer.
	f) Solenoid valve Y1 does not open.	Check for continuity between Y1 and multi-pin plug X5/1 and X5/10 on PC board.
	g) Magnetic coil on solenoid valve Y1 is defective.	Replace coil.
	h) Solenoid valve is defective.	Replace solenoid valve.
	i) Relays on PC board defective.	Replace PC board.
2. Low-Water LED does not illuminate.	a) Water level probe is dirty.	Clean water level probe.
	b) Water level probe is defective.	Replace water level probe.
	c) Bad wire connection to water level probe.	Check wire connection: Black Wire = Low Water Level White Wire = Normal Water Level
	d) Bad wire connection between B1/B2 and multi-pin plug X8/3 and X8/4 on PC board.	Check wire connection.
3. Inner oven cavity flooded with water.	a) Oven drain is blocked.	Clean oven strainer. Clean oven drain. Clean floor drain.
4. Low-Water LED light remains flashing and signal beeps.	a) Incorrect wire connection to water level probe.	Check wire connection: Black Wire = Low Water Level White Wire = Normal Water Level
STEAM GENERATOR TROUBLE		
5. Steam LED light does not illuminate and flash after initial oven start-up <i>or</i> illuminates and keeps flashing after 5 minutes.	a) Safety thermostat (N5) for immersion heater shut off.	Push red button on safety thermostat (N5).
	b) Sensor B4 is defective.	Replace sensor B4.
	c) Loose wires on the main control board.	Check connections X8/7 and X8/8.
	d) Contactor for K1/K2/K3 immersion heating element are not operating.	Check continuity between block terminal 22 and 25, and contactor K1/K2/K3. Check continuity between K1A1 and X5/6. Check continuity between K2A1 and X5/7.
	e) PC board is defective.	Replace the PC board.

COMBITHERM® SERVICE and TROUBLE SHOOTING

PROBLEM	POSSIBLE CAUSE	REMEDY
STEAM GENERATOR TROUBLE		
5. Steam LED light does not illuminate and flash after initial oven start-up <i>or</i> illuminates and keeps flashing after 5 minutes (CONTINUED).	f) Calcium build-up on immersion heating elements.	Decalcify steam generator. See Cleaning & Maintenance section under <i>DECALCIFICATION</i> .
	g) Immersion heating elements defective.	Replace immersion heating elements.
	h) Solenoid coil Y1 is defective.	Replace coil Y1.
	i) Solenoid valve Y1 does not close.	Check continuity between Y1 and multi-pin plug X5/1 and X5/10 on PC board.
	j) Water level probe is dirty.	Clean water level probe.
	k) Water level probe is defective.	Replace water level probe.
	l) Bad wire connection to water level probe.	Check wire connection: Black Wire = Low Water Level White Wire = Normal Water Level
	m) Bad wire connection between B4 and multi-pin plug X8/7 and X8/8 on PC board.	Check wire connection.
6. Immersion heating elements in steam generator produce steam continuously in steam and superheated steam programs.	a) Sensor B5 is defective.	Replace sensor B5.
	b) Bad wire connection on multi-pin plug X8/9 or X8/10 on PC board.	Check wire connection.
	c) Loose by-pass steam hose.	Reconnect by-pass steam hose.
7. Water continuously runs into steam generator.	a) Coil Y1 is defective.	Replace coil Y1.
	b) Solenoid valve is defective.	Replace solenoid valve.
	c) Solenoid valve Y1 does not close.	Check solenoid valve. Check continuity between Y1 multi-pin plug, X5/1 and X5/10 on PC board.
	d) Water level probe is dirty.	Clean water level probe.
	e) Water level probe is defective.	Replace water level probe.
	f) Bad wire connection to water level probe.	Check wire connection: Black Wire = Low Water Level White Wire = Normal Water Level
	g) Bad wire connection between B1/B2 and multi-pin plug X8/3 and X8/4 on PC board.	Check wire connection.
8. Steam generator does not produce steam in the steam or superheated steam program.	a) Sensor B5 is defective.	Replace sensor B5.
	b) Loose connection on multi-pin plug X8/9 or X8/10 on PC board.	Check wire connection.
	c) Door is not closed.	Close the door.
	d) Magnet on door is defective.	Replace magnet.

Prior to performing any work on the oven, it is required that the oven be de-energized. It is of critical importance to disconnect electrical power to the unit by turning off the circuit in the main electrical supply panel. A warning sign indicating the oven is being serviced and the breaker must remain off should be posted on the supply panel.



COMBITHERM® SERVICE and TROUBLE SHOOTING

PROBLEM	POSSIBLE CAUSE	REMEDY
STEAM GENERATOR TROUBLE		
8. Steam generator does not produce steam in the steam or superheated steam program. (CONTINUED)	e) Magnet on door is in the wrong position.	Position magnet correctly.
	f) Bad wire connection between door magnet and multi-pin plug X8/1 or X8/2 on PC board.	Check wire connection.
	g) Door latch interlock switch is defective.	Replace the door latch interlock.
MOTOR TROUBLE		
9. Motor does not start in any program and/or stops unexpectedly.	a) Thermoelement of motor shut off.	Check green LED on PC board.
	b) Wrong motor rotation direction on three-phase ovens.	Change two of the incoming phases to the unit.
	c) Motor is defective.	Replace motor.
	d) Door is not closed.	Close the door.
	e) Magnet on door is in the wrong position.	Position magnet correctly.
	f) Magnet on door is defective.	Replace magnet.
	g) Door latch interlock switch is defective.	Replace the door latch interlock.
	h) Bad wire connection on multi-pin plug X8/1 and X8/2 on PC board.	Check wire connection.
10. Motor does not run in any program, but steam generator operates in both steam and in superheated steam programs.	a) Sensor B4 is defective.	Replace sensor.
	b) Bad wire connection between multi-pin plug X5/5, X5/9 and K5/A1.	Check wire connection.
CONDENSER TROUBLE		
11. Water continuously flows through solenoid valve into condenser.	a) Sensor B3 defective.	Replace sensor B3.
	b) Bad wire connection between sensor B3 and multi-pin plug X8/5 or X8/6 on PC board.	Check wire connection.
	c) Bad wire connection between sensor B5 and multi-pin plug X8/9 and X8/10.	Check wire connection.
	d) Solenoid valve is defective.	Replace solenoid valve.
	e) Solenoid valve Y2 remains open.	Check solenoid valve. Check continuity between coil Y2 and multi-pin plug X5/1 and X5/11 on PC board.
	f) Coil Y2 is defective.	Replace coil Y2.

Prior to performing any work on the oven, it is required that the oven be de-energized. It is of critical importance to disconnect electrical power to the unit by turning off the circuit in the main electrical supply panel. A warning sign indicating the oven is being serviced and the breaker must remain off should be posted on the supply panel.



COMBITHERM® SERVICE and TROUBLE SHOOTING

PROBLEM	POSSIBLE CAUSE	REMEDY
CONDENSER TROUBLE (CONTINUED)		
12. Water does not flow through solenoid valve into condenser.	a) Sensor B3 is defective.	Replace sensor B3.
	b) Bad wire connection between coil Y2 and multi-pin plug X5/1 and X5/11 on PC board.	Check wire connection.
	c) Solenoid valve is defective.	Replace solenoid valve.
	d) Solenoid valve Y2 remains closed.	Check solenoid valve. Check continuity between coil Y2 and multi-pin plug X5/1 and X5/11 on PC board.
	e) Coil Y2 is defective.	Replace coil Y2.
CONVECTION TROUBLE		
13. Unit does not heat in convection or superheated steam programs.	a) A fuse is blown.	Replace fuse.
	b) Contactor is defective which could include K41, K42, K61, and/or K62.	Replace contactor.
	c) Thermostat is defective.	Replace thermostat.
	d) Loose wire connection between X5/8 or X5/1 and contactor.	Check wire connection.
	e) Safety Thermostat (N7) for convection heater has shut off.	Push red button on safety thermostat (N7).
14. Unit does not heat in convection or superheated steam programs but the convection LED indicator light is illuminated.	a) Convection heating element is defective.	Replace convection heating element.
	b) Over-ride thermostat is defective or has tripped (N7).	Replace over-ride thermostat.
	c) Loose wire connection.	Check wire connection or reset thermostat.
GENERAL TROUBLE		
15. Control fuse blows when power switch is turned to the ON position.	a) Short circuit of electrical coils.	Replace defective coils (CONTACTOR).
	b) Bad wire connection(s).	Check all wires for tight connections.
16. Fuse on PC board blows approximately 6 to 7 minutes into oven operation.	a) Solenoid valve coil Y2 for cooling is short circuited.	Replace coil Y2 of solenoid valve.
17. All oven function operate but audible signal does not activate.	a) Audible signal on diode board may be defective.	Replace diode board.
18. None of the oven functions operate after switching the unit ON but interior oven light(s) illuminate.	a) Fuse F1 is defective.	Replace fuse.
	b) Operation board or connection to board is defective.	Check connection and/or replace operation board or wire.
19. Interior oven light or lights do not illuminate.	a) Interior oven light is burned out.	Replace light bulb.
	b) Light socket is defective.	Replace light socket.
	c) Fuse F2 or F3 on PC board is blown.	Replace fuse F2 or F3.

COMBITHERM® SERVICE and TROUBLE SHOOTING

PROBLEM	POSSIBLE CAUSE	REMEDY
GENERAL TROUBLE (CONTINUED)		
20. None of the oven program functions operate after switching the unit ON.	a) Power switch Q1 is defective.	Replace switch Q1.
	b) Bad connection on power switch.	Check wiring.
	c) Plug X4 or X6 is loose.	Check connections.
21. Audible signal does not activate during the Core Temp program mode when internal temperature is reached.	a) Audible signal is defective.	Replace diode board.
	b) Loose connection at X9/3 or X9/4.	Check connections.
	c) Core Temp probe is defective.	Replace probe.
22. No LED display after pressing the Core Temp program function.	a) Bad connection at X9/3 or X9/4.	Check connections.
	b) Operation board defective.	Replace Operation board.
23. "E10" appears in the display after pressing the Core Temp program function.	a) Product probe is defective.	Replace product probe.
24. "E06" appears in the display after pressing the Convection or the Superheated Steam and Convection program function.	a) Oven temp probe is defective.	Replace oven temp probe.
25. Water has seeped into the oven control area.	a) Interior oven light seal is defective.	Replace interior oven light seal.
	b) Motor shaft seal is defective.	Replace motor shaft seal.
	c) Convection heater seal is defective.	Replace convection heater seal.

Prior to performing any work on the oven, it is required that the oven be de-energized. It is of critical importance to disconnect electrical power to the unit by turning off the circuit in the main electrical supply panel. A warning sign indicating the oven is being serviced and the breaker must remain off should be posted on the supply panel.



COMBITHERM® SERVICE and TROUBLE SHOOTING

MODEL 20•20 — REPLACEMENT PARTS

MECHANICAL PARTS

Drain Screen	DA-2943
Oven Light Bulb	LP-3686
Oven Light Cover	CV-23896
Oven Light Glass Cover	LP-33413
Oven Light Cover Mounting Screws (8)	SC-22281
Oven Light Receptacle	RP-3986
Oven Light Seal	SA-23933
Oven Light O-Ring	SA-23934
Product Probe	PR-33286
Fan Wheel	WH-3734
Pivot Pin Direction Panel	PI-23929
Feet, Flanged Adjustable	FE-23822

DOOR PARTS

Door Handle	HD-2934
Door Hinge Set	HG-22850
Door Latch	LT-2935
Door Magnet, Permanent Solenoid	MA-3739
Door Gasket	GS-2954
Door Assembly	15318

WATER / PLUMBING PARTS

Double Solenoid Valve Assembly	VA-3820
Double Solenoid Valve Body	VA-2926
Double Solenoid Valve Coil	VA-3681
Hand Held Shower Assembly	14577
includes:	
— Hand Shower Sprayer	PB-23919
— Hand Shower Handle	PB-23920
— Hand Shower Hose	PB-24066
Hand Shower Holder	PB-23921

ELECTRICAL / ELECTRONIC PARTS

Interlock Switch	LT-3738
Operation Board	BA-33399
Programming Board (DELUXE MODELS)	BA-33400
Ribbon Cable	CB-33298
Convection Heater	EL-3853
Cooling Fan (2)	FA-3568
Motor Contactor K5 (2)	CN-3652
Safety Thermostat	TT-3750
208-240V, 3 ph: —————	
— Fuse, 15 Amp, Class G (3)	FU-3775
— Fuse, 35 Amp, Class G (9)	FU-33127
— Fuse, 45 Amp, Class G (12)	FU-33040
— Fuse Holder; 3 pole	FU-3842
— Fuse Holder; 3 pole	FU-33039
— Fuse — Main Control Board; 1 Amp	FU-3674
— Fuse — Main Control Board; 0.25 Amp	FU-3673
— Heater Contactor	CN-3731
— Motor Assembly, 3 Phase AC (2)	14440
— Motor Protection Switch	SW-33378
440-480V, 3 ph: —————	
— Fuse, 15 Amp, Class J (3)	FU-3998
— Fuse, 20 Amp, Class G (8)	FU-3999
— Fuse, 25 Amp, Class J (12)	FU-33001
— Fuse Holder	FU-33128
— Fuse — Main Control Board; 1 Amp	FU-3674
— Fuse — Main Control Board; 0.25 Amp	FU-3673
— Heater Contactor	CN-3654
— Motor Assembly, 3 Phase AC (2)	14885
— Motor Protection Switch	SW-33379

MISCELLANEOUS PARTS

Shelf, Stainless Steel	SH-22473
Roll-In Cart, Stainless Steel	5815
Gasket, Control Panel	GS-23622

Prior to performing any work on the oven, it is required that the oven be de-energized. It is of critical importance to disconnect electrical power to the unit by turning off the circuit in the main electrical supply panel. A warning sign indicating the oven is being serviced and the breaker must remain off should be posted on the



- B1 LOW WATER PROBE PR-3706
- B2 WATER LEVEL PROBE PR-33289
- B3 TEMPERATURE PROBE (CONDENSOR RESERVOIR) PR-33289
- B4 TEMPERATURE PROBE (STEAM GENERATOR) PR-33289
- B5 STEAM BYPASS PROBE PR-33289
- Y1 SOLENOID VALVE VA-3820
- Y2 SOLENOID VALVE VA-3820
- E1/E2/E3 STEAMGENERATOR HEAT ELEMENTS EL-3855 208/240V EL-33087 440/480V
- 1 STEAM GENERATOR RESERVOIR
- 2 INNER OVEN CAVITY
- 3 CONDENSER RESERVOIR
- 4 WATER INLET TO CONDENSOR
- 5 WATER INLET TO STEAM GENERATOR
- 6 UPPER WATER TRAP
- 7 BYPASS STEAM HOSE
- 8 STEAM OUTLET TO OVEN CAVITY
- 9 STEAM RESERVOIR DRAIN TO OVEN CAVITY
- 10 BREATHER PIPE
- 11 WATER DRAIN
- 12 WATER FEED
- 13 CONDENSER RESERVOIR DRAIN PLUG
- 14 PRESSURE RELIEF VALVE (ONE WAY)

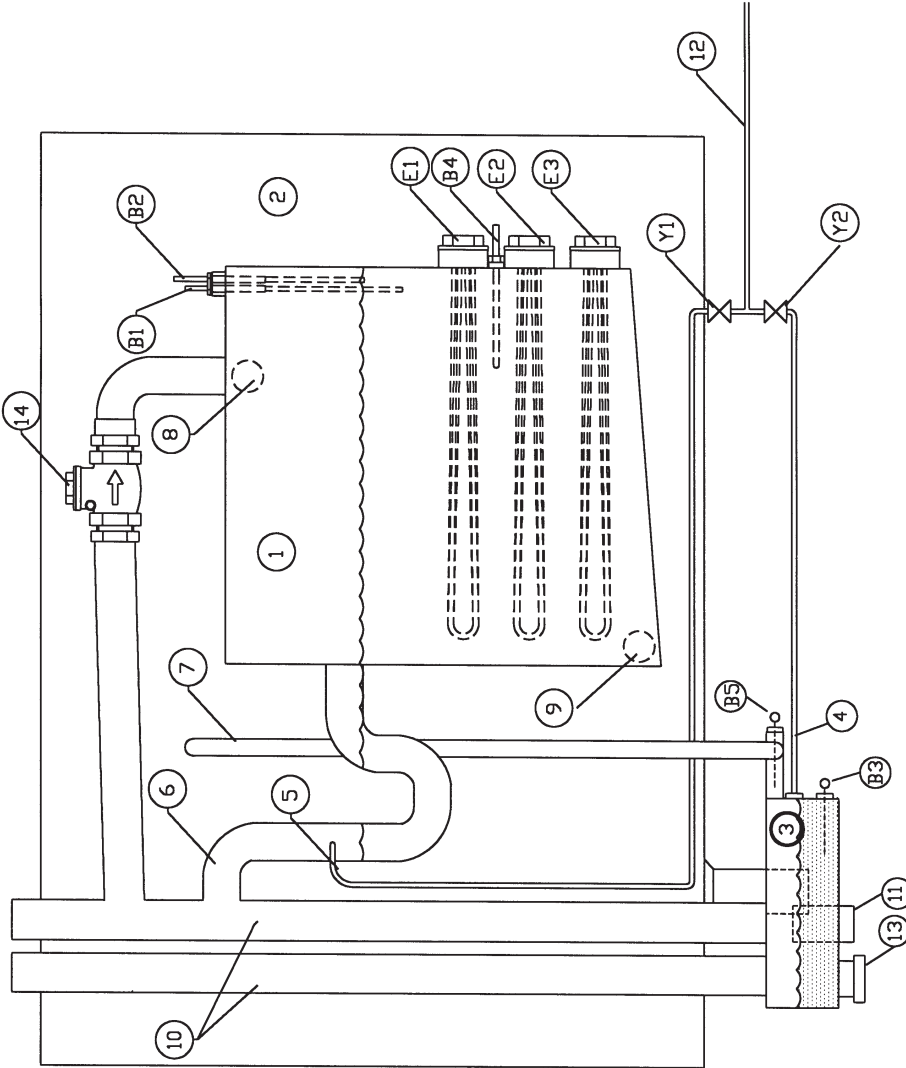

REVISIONS	
NO.	DATE
1	
2	
3	
4	
5	

2020 ELECTRONIC CONTROL	
BASIC SYSTEM DIAGRAM	
ALTO-SHAAM INC. MENDOTA FALLS, WISCONSIN	
DRAWN BY RS	SCALE 1/8"=1" DWG. NO.
APP'D M.S.	DATE 4/30/97 A-8799

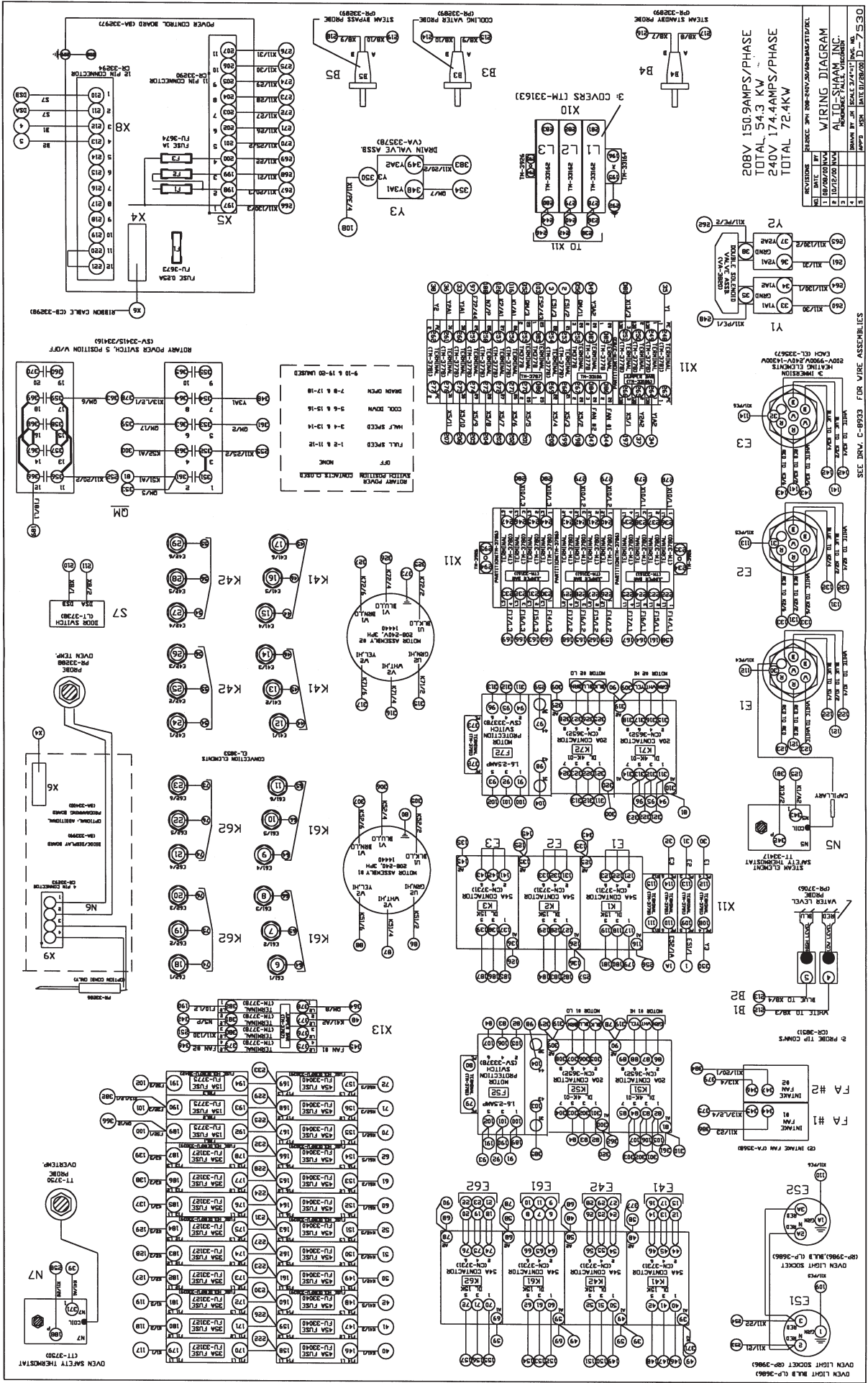

REV	DATE	BY	DESCRIPTION
1	10/15/00	ALLO-SHAAM, INC.	WIRING DIAGRAM
2	10/15/00	ALLO-SHAAM, INC.	REVISIONS
3	10/15/00	ALLO-SHAAM, INC.	REVISIONS
4	10/15/00	ALLO-SHAAM, INC.	REVISIONS
5	10/15/00	ALLO-SHAAM, INC.	REVISIONS

208V 150.9AMPS/PHASE
 TOTAL 54.3 KW
 240V 174.4AMPS/PHASE
 TOTAL 72.4KW

SEE DRAW. C-6923 FOR WIRE ASSEMBLIES

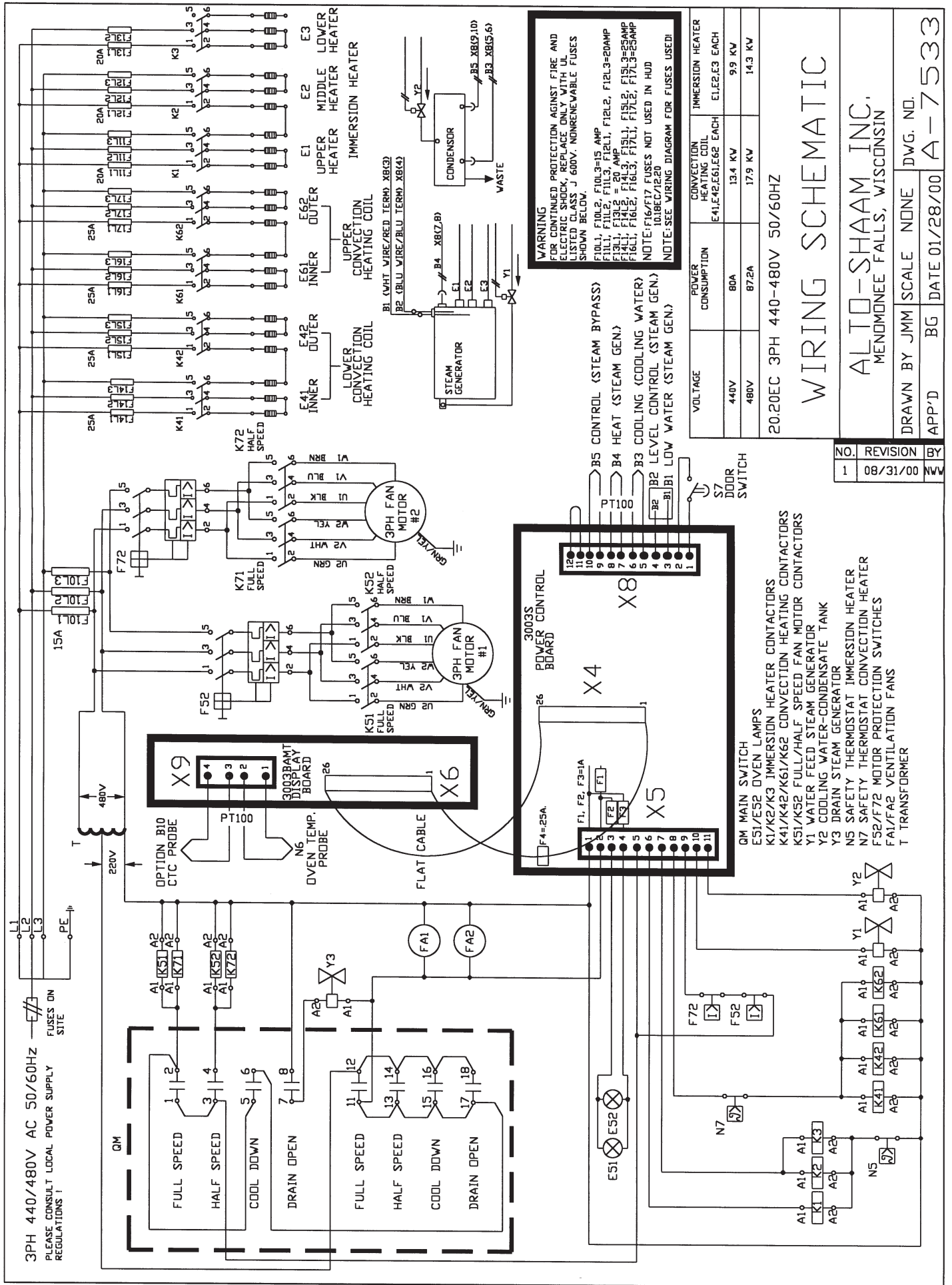

NO.	REVISION	BY
1	08/31/00	WV

VOLTAGE	POWER CONSUMPTION	CONVECTION HEATING COIL	IMMERSION HEATER
440V	80A	E41,E42,E61,E62 EACH	E1,E2,E3 EACH
480V	87.2A	13.4 KV	9.9 KV
20•20EC 3PH 440-480V 50/60HZ		17.9 KV	14.3 KV

WIRING SCHEMATIC

ALTO-SHAAM INC.
MENDONNEE FALLS, WISCONSIN

DRAWN BY JMM SCALE NONE DWG. NO. A-7533
 APP'D BG DATE 01/28/00

TRANSPORTATION DAMAGE and CLAIMS

ALTO-SHAAM® LIMITED WARRANTY



All Alto-Shaam equipment is sold F.O.B. shipping point, and when accepted by the carrier, such shipments become the property of the consignee.

Should damage occur in shipment, it is a matter between the carrier and the consignee. In such cases, the carrier is assumed to be responsible for the safe delivery of the merchandise, unless negligence can be established on the part of the shipper.

1. Make an immediate inspection while the equipment is still in the truck or immediately after it is moved to the receiving area. Do not wait until after the material is moved to a storage area.
2. Do not sign a delivery receipt or a freight bill until you have made a proper count and inspection of all merchandise received.
3. Note all damage to packages directly on the carrier's delivery receipt.
4. Make certain the driver signs this receipt. If he refuses to sign, make a notation of this refusal on the receipt.
5. If the driver refuses to allow inspection, write the following on the delivery receipt:
Driver refuses to allow inspection of containers for visible damage.
6. Telephone the carrier's office immediately upon finding damage, and request an inspection. Mail a written confirmation of the time, date, and the person called.
7. Save any packages and packing material for further inspection by the carrier.
8. Promptly file a written claim with the carrier and attach *copies* of all supporting paperwork.

We will continue our policy of assisting our customers in collecting claims which have been properly filed and actively pursued. We cannot, however, file any damage claims for you, assume the responsibility of any claims, or accept deductions in payment for such claims.

Alto-Shaam, Inc. warrants to the original purchaser that any original part that is found to be defective in material or workmanship will, at our option, subject to provisions hereinafter stated, be replaced with a new or rebuilt part.

The labor warranty remains in effect one (1) year from installation or fifteen (15) months from the shipping date, whichever occurs first.

The parts warranty remains in effect one (1) year from installation or fifteen (15) months from the shipping date, whichever occurs first.

This warranty does not apply to:

1. Calibration
2. Replacement of light bulbs and/or the replacement of deli display case glass due to damage of any kind.
3. Equipment damage caused by accident, shipping, improper installation or alteration.
4. Equipment used under conditions of abuse, misuse, carelessness or abnormal conditions.
5. Any losses or damage resulting from malfunction, including loss of product or consequential or incidental damages of any kind.
6. Equipment modified in any manner from original model, substitution of parts other than factory authorized parts, removal of any parts including legs, or addition of any parts.

This warranty is exclusive and is in lieu of all other warranties, expressed or implied, including the implied warranties of merchantability and fitness for purpose. In no event shall the Company be liable for loss of use, loss of revenue, or loss of product or profit, or for indirect or consequential damages. This warranty is in lieu of all other warranties expressed or implied and Alto-Shaam, Inc. neither assumes or authorizes any persons to assume for it any other obligation or liability in connection with Alto-Shaam equipment.

ALTO-SHAAM, INC.

Warranty effective January 1, 2000

Record the model and serial numbers of the unit for easy reference.

Always refer to both model and serial numbers in your correspondence regarding the unit.

Model: _____

Serial Number: _____

Purchased From: _____

Date Installed: _____ Voltage: _____



COMBITHERM®

Manufactured by Alto-Shaam, Inc.

W 164 N 9221 Water Street • P.O. Box 450 • Menomonee Falls, Wisconsin 53052-0450 • U.S.A.
PHONE: (262)251-3800 (800)558-8744 U.S.A./CANADA • FAX: (262)251-7067 (800)329-8744 U.S.A. (262)251-1907 INTERNATIONAL • www.alto-shaam.com