

ALTO SHAAM® HALO HEAT®



200-HFT



300-HFT

INSTALLATION OPERATION AND MAINTENANCE MANUAL

HOT FOOD TABLE ELECTRIC

MODELS:

200-HFT

(or base only)

300-HFT

(or base only)

W164 N9221 Water Street • P.O. Box 450 • Menomonee Falls, Wisconsin 53052-0450 U.S.A.

PHONE: 262.251.3800

800.558-8744 U.S.A./CANADA

FAX: 262.251.7067 • 800.329.8744 U.S.A. ONLY

262.251.1907 INTERNATIONAL

WEBSITE:

www.alto-shaam.com

ALTO-SHAAM® - Heated Buffet Tables

UNPACKING and SET-UP

The Alto-Shaam Hot Food Table has been thoroughly tested, and inspected to insure only the highest quality unit is provided. When you receive your unit, check for any possible shipping damage and report it at once to the delivering carrier. See *Transportation Damage and Claims* section located in this manual.

Save all the information and instructions packed with the unit. Complete and return the warranty card to the factory as soon as possible to assure prompt service in the event of a warranty parts and labor claim.

NOTE: All claims for warranty must include the full model number and serial number of the unit.

START-UP

Before operating the unit, clean the interior and exterior with a damp, clean cloth and mild soap solution. Rinse carefully.

ELECTRICAL INSTALLATION

1. An identification tag is permanently mounted on the case.

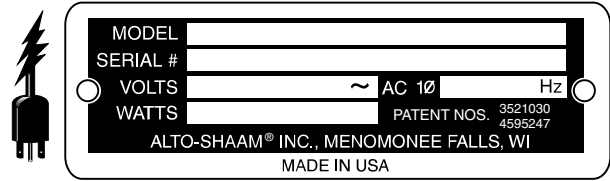

2. Plug the unit into a properly grounded receptacle ONLY, positioning the unit so that the plug is easily accessible in case of an emergency. Arcing will occur when connecting or disconnecting the unit unless all controls are in the "OFF" position.
3. Proper receptacle or outlet configuration or permanent wiring for this unit must be installed by a licensed electrician in accordance with applicable local electrical codes.

**ENSURE POWER SOURCE MATCHES
VOLTAGE STAMPED ON UNIT NAMEPLATE**



INSTALLATION

Sneeze Guard

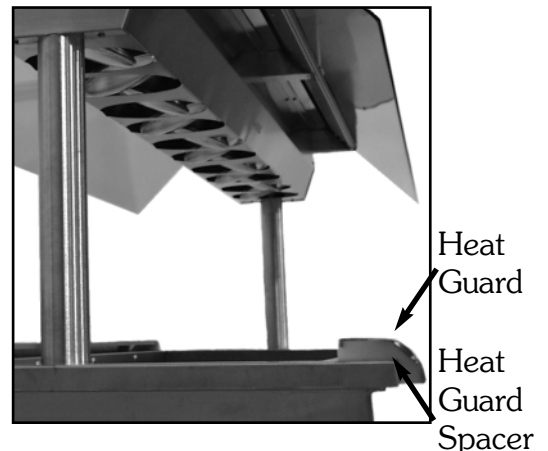
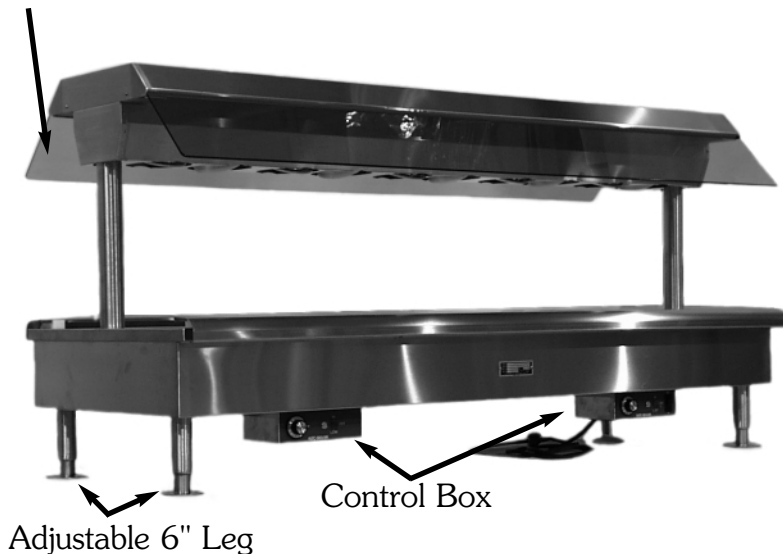

INSTALLATION

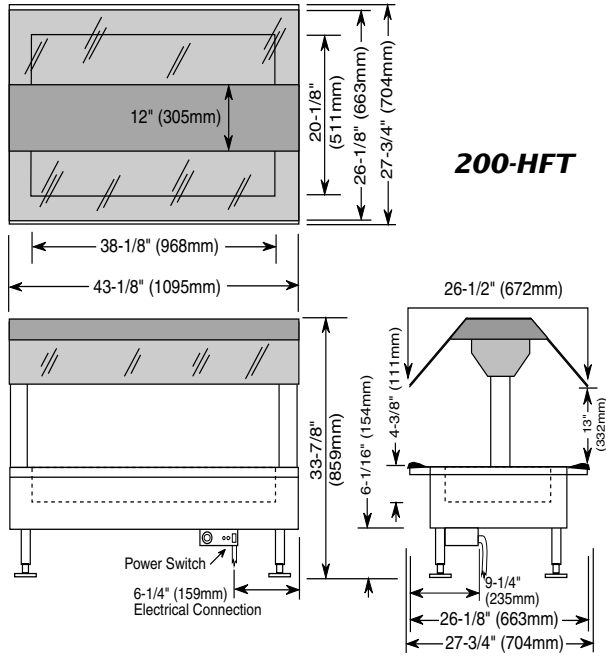

Outside Dimensions

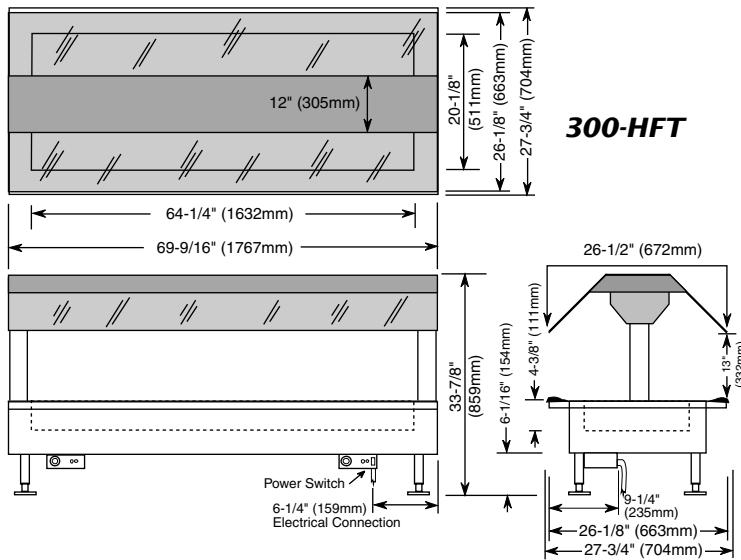

OPTION

Decorator Cart — 200-HFT

Part No.

- with shelf55185
- painted decor panel package44075
- stainless steel decor panel package . . .44078

Decorator Cart — 300-HFT

Part No.

- with shelves55181
- painted decor panel package44073
- stainless steel decor panel package . . .44076
- roll-in55728
- painted decor panel package44073
- stainless steel decor panel package . . .44076
- fully enclosed55183
- painted decor panel package44074
- stainless steel decor panel package . . .44077



#55728



#55181

Options and Accessories

- Custom Panel ColorsFACTORY QUOTE
- Pan Divider Bars
 - Full-Size16019
 - Half-Size • Third-Size11318
- 300-HFT Customer Sneeze Guard, large
 - Front Guard44149
 - End Guard44239

SPECIAL INFORMATION

- Pans are not included.
- Opening required for drop-in countertop applications:
 - 300-HFT • 25" x 69-1/2" (635mm x 1765mm)
 - 200-HFT • 25" x 43-1/8" (635mm x 1095mm)

INSTALLATION

200-HFT • Pan Configurations

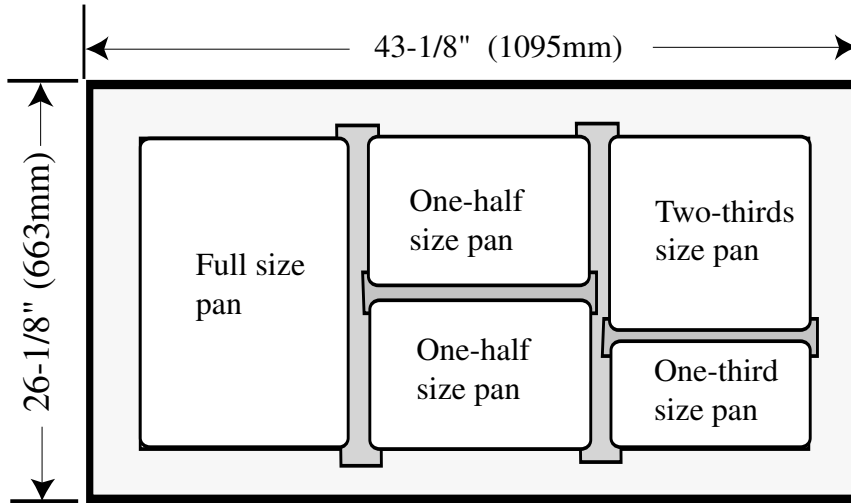

Quantities	Quantities	Quantities
Full size pans	One-half size pans	two-third size pans
1 to 3	2, 4, 6	One-third size pans
		1 to 3 sets

Standard Pan Sizes

Full-size pans	12" x 20" x 2-1/2"	(325mm x 530mm x 65mm)	GN 1/1
One-half size pan	12" x 10" x 2-1/2"	(325mm x 265mm x 65mm)	GN 1/2
Two-thirds size pan	12" x 14" x 2-1/2"	(325mm x 352mm x 65 mm)	GN 2/3
One-third size pan	12" x 6" x 2-1/2"	(325mm x 176mm x 65mm)	GN 1/3

Standard Pan Divider and Separator Bars

Pan Divider Bars	#16019	Quantity - 2
Half or Third Size Pan Separator Bars	#11318	Quantity - 3

INSTALLATION

300-HFT • PAN CONFIGURATIONS

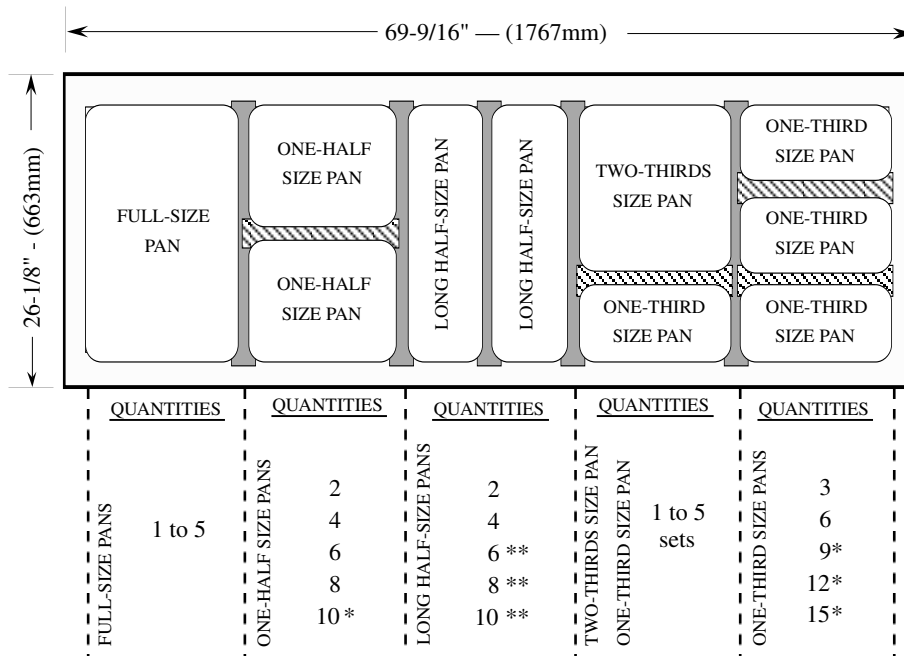

STANDARD PAN SIZES			
FULL-SIZE PAN	12" x 20" x 2-1/2"	325mm x 530mm x 65mm	GN 1/1
ONE-HALF SIZE PAN	12" x 10" x 2-1/2"	325mm x 265mm x 65mm	GN 1/2
LONG-HALF SIZE PAN	6" x 20" x 2-1/2"	162mm x 530mm x 65mm	GN 2/4
TWO-THIRDS SIZE PAN	12" x 14" x 2-1/2"	325mm x 352mm x 65mm	GN 2/3
ONE-THIRD SIZE PAN	12" x 6" x 2-1/2"	325mm x 176mm x 65mm	GN 1/3
FULL-SIZE SHEET PAN	18" x 26" x 1"	N/A	
HALF-SIZE SHEET PAN	18" x 13" x 1"	N/A	

STANDARD PAN DIVIDER and SEPARATOR BARS	
#16019 PAN DIVIDER BARS	<u>QUANTITIES</u> 4
#11318 HALF OR THIRD-SIZE PAN SEPARATOR BARS	5

* Additional Pan Separator Bars Required
 ** Additional Pan Divider Bars Required

OPERATION PROCEDURES

1. DO NOT ADD WATER TO THE UNIT.

Halo Heat buffet servers maintain a constant but gentle temperature and eliminate much of the moisture loss associated with conventional holding methods. Because of this gentle heat, it is not necessary to add water to the hot food table. Adding water is not recommended since water will accelerate the deterioration of the product, presents an electrical hazard, and may damage the table and void the warranty.

2. PLACE DIVIDER BARS & PANS INTO UNIT.

Refer to the pan layout diagrams for different types of pan accommodations. A complete pan configuration layout is located in this manual. It is VERY important to note that pan separator bars or divider bars must be used to close all gaps between pans and all gaps between the pans and the edges of the table; otherwise, heat distribution will be uneven, and uniform temperature will be difficult to maintain. Additional pan divider bars are available if needed.

3. TURN ON LIGHTS (if applicable).

To extend the life of the bulbs, it is recommended to turn on the lights while preheating the unit.

4. PREHEAT BY SETTING THERMOSTATS TO NUMBER "10".

An indicator light will illuminate when each thermostat is turned "ON." These indicators will remain lit as long as the unit is preheating or calling for heat. The unit should be preheated, at the number 10 setting, for a minimum of thirty minutes before loading with food. When preheating is completed, or whenever the unit reaches any temperature set by the operator between 1 and 10, the indicator light(s) will go "OUT".

5. LOAD HOT FOODS INTO HOT FOOD TABLE.

Be certain only hot food is transferred into the hot food table. Before loading food into the table, use a pocket-type meat thermometer to make certain all products have reached an internal temperature of 140° to 180° F (60° to 82°C). If any food product is not at proper serving temperature, use a Halo Heat cooking and holding oven, set at 250° to 275°F (121° to 135°C), or a Combitherm oven to bring the product within the correct temperature range.

6. RESET THERMOSTAT AS NEEDED.

After all products are loaded into the hot food table, reset the thermostat(s) to the number "8" setting. **THIS WILL NOT NECESSARILY BE THE FINAL SETTING.** Since proper temperature range depends on the type of products and the quantities being held, it is necessary to periodically use a pocket thermometer to check each item to make certain the correct temperatures are being maintained. Proper temperature range is between 140° and 180°F (60° and 82°C). Normally, this will require a thermostat setting of between number "6" and "8", although a higher or lower setting may sometimes be required.

7. SERVE FRESH HOT FOOD.

Keep hot foods looking fresh. Occasionally stir or rotate foods as needed. Wipe spills immediately to assure maximum eye appeal and minimize end-of-the-day cleanup.

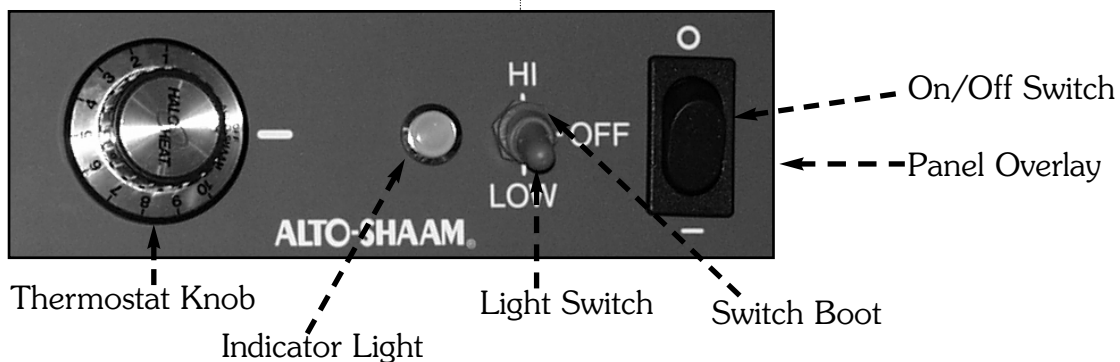

GENERAL HOLDING GUIDELINES

Chefs, cooks and other specialized food service personnel Chefs, cooks, and other specialized food service personnel employ varied methods of cooking. Proper holding temperatures for a specific food product must be based on the moisture content of the product, product density, volume, and proper serving temperatures. Safe holding temperatures must also be correlated with palatability in determining the length of holding time for a specific product.

Halo Heat maintains the maximum amount of product moisture content without the addition of water, water vapor, or steam. Maintaining maximum natural product moisture preserves the natural flavor of the product and provides a more genuine taste. In addition to product moisture retention, the gentle properties of Halo Heat maintain a consistent temperature throughout the cabinet without the necessity of a heat distribution fan, thereby preventing further moisture loss due to evaporation or dehydration.

HOLDING TEMPERATURE RANGE		
	FAHRENHEIT	CELSIUS
MEAT		
BEEF ROAST — Rare	140°F	60°C
BEEF ROAST — Med/Well Done	160°F	71°C
BEEF BRISKET	160° — 175°F	71° — 79°C
CORN BEEF	160° — 175°F	71° — 79°C
PASTRAMI	160° — 175°F	71° — 79°C
PRIME RIB — Rare	140°F	60°C
STEAKS — Broiled/Fried	140° — 160°F	60° — 71°C
RIBS — Beef or Pork	160°F	71°C
VEAL	160° — 175°F	71° — 79°C
HAM	160° — 175°F	71° — 79°C
PORK	160° — 175°F	71° — 79°C
LAMB	160° — 175°F	71° — 79°C
POULTRY		
CHICKEN — Fried/Baked	160° — 175°F	71° — 79°C
DUCK	160° — 175°F	71° — 79°C
TURKEY	160° — 175°F	71° — 79°C
GENERAL	160° — 175°F	71° — 79°C
FISH/SEAFOOD		
FISH — Baked/Fried	160° — 175°F	71° — 79°C
LOBSTER	160° — 175°F	71° — 79°C
SHRIMP — Fried	160° — 175°F	71° — 79°C
BAKED GOODS		
BREADS/ROLLS	120° — 140°F	49° — 60°C
MISCELLANEOUS		
CASSEROLES	160° — 175°F	71° — 79°C
DOUGH — Proofing	80° — 100°F	27° — 38°C
EGGS —Fried	150° — 160°F	66° — 71°C
FROZEN ENTREES	160° — 175°F	71° — 79°C
HORS D'OEUVRES	160° — 180°F	71° — 82°C
PASTA	160° — 180°F	71° — 82°C
PIZZA	160° — 180°F	71° — 82°C
POTATOES	180°F	82°C
PLATED MEALS	180°F	82°C
SAUCES	140° — 200°F	60° — 93°C
SOUP	140° — 200°F	60° — 93°C
VEGETABLES	160° — 175°F	71° — 79°C
The holding temperatures listed are suggested guidelines only.		

In an enclosed holding environment, too much moisture content is a condition which can be relieved. A product achieving extremely high temperatures in preparation must be allowed to decrease in temperature before being placed in a controlled holding atmosphere. If the product is not allowed to decrease in temperature, excessive condensation will form, increasing the moisture content on the outside of the product.

Most Halo Heat holding equipment is provided with a thermostat control between 60° and 200°F (16° to 93°C). If the unit is equipped with vents, close the vents for moist holding and open the vents for crisp holding.

If the unit is equipped with a thermostat indicating a range of between 1 and 10, use a metal-stemmed indicating thermometer to measure the internal temperature of the product(s) being held. Adjust the thermostat setting to achieve the best overall setting based on internal product temperature.

SANITATION

Food flavor and aroma are usually so closely related that it is difficult, if not impossible, to separate them. There is also an important, inseparable relationship between cleanliness and food flavor. Cleanliness, top operating efficiency, and appearance of equipment contribute considerably to savory, appetizing foods. Good equipment that is kept clean, works better and lasts longer.

Most food imparts its own particular aroma and many foods also absorb existing odors. Unfortunately, during this absorption, there is no distinction between *GOOD* and *BAD* odors. The majority of objectionable flavors and odors troubling food service operations are caused by bacteria growth. Sourness, rancidity, mustiness, stale or other *OFF* flavors are usually the result of germ activity.

The easiest way to insure full, natural food flavor is through comprehensive cleanliness. This means good control of both visible soil (dirt) and invisible soil (germs). A thorough approach to sanitation will provide essential cleanliness. It will assure an attractive appearance of equipment, along with maximum efficiency and utility. More importantly, a good sanitation program provides one of the key elements in the prevention of food-borne illnesses.

A controlled holding environment for prepared foods is just one of the important factors involved in the prevention of food-borne illnesses. Temperature monitoring and control during receiving, storage, preparation, and the service of foods are of equal importance.

The most accurate method of measuring safe temperatures of both hot and cold foods is by internal product temperature. A quality thermometer is an effective tool for this purpose, and should be routinely used on all products that require holding at a specific temperature.

A comprehensive sanitation program should focus on the training of staff in basic sanitation procedures. This includes personal hygiene, proper handling of raw foods, cooking to a safe internal product temperature, and the routine monitoring of internal temperatures from receiving through service.

Most food-borne illnesses can be prevented through proper temperature control and a comprehensive program of sanitation. Both these factors are important to build quality service as the foundation of customer satisfaction. Safe food handling practices to prevent food-borne illness is of critical importance to the health and safety of your customers. HACCP, an acronym for Hazard Analysis (at) Critical Control Points, is a quality control program of operating procedures to assure food integrity, quality, and safety. Taking steps necessary to augment food safety practices are both cost effective and relatively simple. While HACCP guidelines go far beyond the scope of this manual, additional information is available by contacting the USDA/FDA Food-borne Illness Education Information Center at (301) 504-6803.

INTERNAL FOOD PRODUCT TEMPERATURES		
HOT FOODS		
DANGER ZONE	40° TO 140°F	(4° TO 60°C)
CRITICAL ZONE	70° TO 120°F	(21° TO 49°C)
SAFE ZONE	140° TO 165°F	(60° TO 74°C)
COLD FOODS		
DANGER ZONE	ABOVE 40°F	(ABOVE 4°C)
SAFE ZONE	36°F TO 40°F	(2°C TO 4°C)
FROZEN FOODS		
DANGER ZONE	ABOVE 32°F	(ABOVE 0°C)
CRITICAL ZONE	0° TO 32°F	(-18° TO 0°C)
SAFE ZONE	0°F OR BELOW	(-18°C OR BELOW)

CARE & CLEANING



The cleanliness and appearance of this unit will contribute considerably to operating efficiency and savory, appetizing food. Good equipment kept clean works better and lasts longer.

THOROUGHLY CLEAN THE UNIT DAILY

1. Disconnect unit from power source, and let cool.
2. Remove, cover or wrap, and refrigerate food.
3. Clean the interior metal surfaces of the unit with a damp, clean cloth and any good commercial detergent or grease solvent at the recommended strength. Use a plastic scouring pad or oven cleaner for difficult areas. Rinse carefully to remove all residue and wipe dry.



NO SCRAPERS



NO STEEL PADS

4. Clean sneeze guard with mild detergent and water. Dry with clean damp chamois. Avoid scratching, and do not use dry cloths or scouring compounds.
5. To help maintain the protective film coating on polished stainless steel, clean the exterior of the unit with a cleaner recommended for stainless steel surfaces. Spray the cleaning agent on a clean cloth and wipe with the grain of the stainless steel.

NOTE: Avoid the use of abrasive cleaning compounds, chloride based cleaners, or cleaners containing quaternary salts. Never use hydrochloric acid (muriatic acid) on stainless steel.

Always follow appropriate state or local health (hygiene) regulations regarding all applicable cleaning and sanitation requirements for equipment.



***At no time should the inside or outside of the unit be washed down, flooded with water or liquid solution.
NEVER STEAM CLEAN.
Do not use water jet to clean.***



***Severe damage or electrical hazard could result.
Warranty becomes void if unit is flooded.***

SERVICE SECTION

Always disconnect unit from power source before cleaning or servicing.

If the power cord needs replacement, contact factory for exact replacement. Use of any other cord may result in electrical or fire hazard.



Heat Cable Replacement Kit

#4878 #4881
200-HFT 300-HFT

includes:

CB-3045	Cable Heating Element .72 feet210 feet
CR-3226	Ring Connector412
IN-3488	Insulation Corner1 foot1 foot
BU-3105	Shoulder Bushing412
BU-3106	Cup Bushing412
SL-3063	Insulating Sleeve412
TA-3540	High Temperature Tape . .1 roll1 roll
NU-2215	Hex Nut824
ST-2439	Stud412

SAFETY ALERT



This units performance has been optimized using factory provided bulbs. These bulbs should be replaced with an exact replacement



or with a factory recommended replacement. These bulbs must be replaced with similar bulbs in order to maintain compliance with NSF standards. To avoid filament damage, do not overtighten bulbs in their receptacles. It is recommended that bulbs be preheated with the unit.

SERVICE PARTS LIST

4/30/04

	Part No.	200-HFT Qty	300 HFT Qty
1. Sneeze Guard	GD-24772	-	2
Sneeze Guard	GD-24735	2	-
2. Control Box, w/switch,125V	44006	1	2
Control Box, w/switch, 208/240V, 230V	44138	1	1
Control Box, w/o switch, 208/240V, 230V	16171	-	1
3. Heat Guard	16071	2	-
Heat Guard	16175	-	2
4. Heat Guard Spacer	SP-24586	4	4
5. Leg, 6" (152mm)	LG-23067	4	4
6. Bulb, 100W, 125V	LP-33592	6	10
Bulb, 100W, 208/240V, 230V	LP-33783	6	10
7. Bulb Receptacle, 125V	RP-3952	6	10
Bulb Receptacle, 230V, 208/240V	RP-3955	6	10
8. Thermostat Knob	KN-3473	1	2
9. Thermostat	TT-3498	1	2
10. Indicator Light, 125V	LI-3027	1	2
Indicator Light, 208/240V	LI-3025	1	2
Nut, Indicator Light	NU-3335	1	2
Indicator Light, 230V	LI-3951	1	2
11. Light Toggle Switch, 125V, 208/240V	SW-3616	1	2
Light Toggle Switch, 230V	SW-33726	1	2
12. Switch Boot	SW-3905	1	2
13. On/Off Rocker Switch, 125V	SW-33648	1	2
On/Off Rocker Switch, 208/240V, 230V	SW-33487	1	1
14. Panel Overlay, w/switch,125V	PE-24665	1	2
Panel Overlay, w/switch, 208/240V, 230V	PE-24665	1	1
Panel Overlay, w/o switch, 208/240V, 230V	PE-24666	-	1
15. Insulation, 1/2"x 24"x 48" (18mm x 610mm x 1219mm)	IN-2003	1	1
16. Terminal Block, 125V, 208/240V	BK-3021	1	1
Terminal Block, 230V	BK-3597	1	1
17. Gasket	GS-2750	4'(1.2m)	2.7'(.8m)
	GS-2019	-	1.7'(.5m)
18. Heat Cable	CB-3045	62'(18.9m)	140.5'(43m)
19. Fuse, 125V only	FU-3775	-	2
Fuse holder, 125V only	FU-33041	-	2
Cordset, 125V	CD-33367	1	-
Cordset, 125V	CD-33366	-	1
Cordset, 208-240V	CD-3551	1	-
Cordset, 208-240V	CD-3607	-	1
Plug	PG-33236	-	1
Cordset, 230V, Euro	CD-33469	1	1
Cordset, 230V, U.K., option	CD-33471	1	1
Inlet, 230V	IT-33306	1	1

See following page for illustrations.

SERVICE SECTION

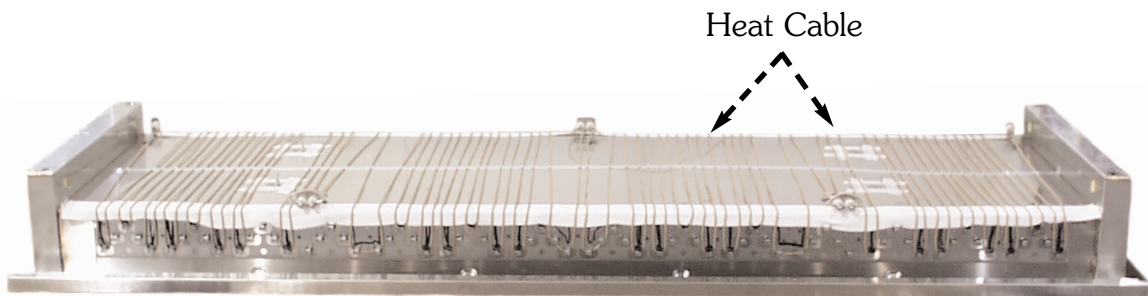
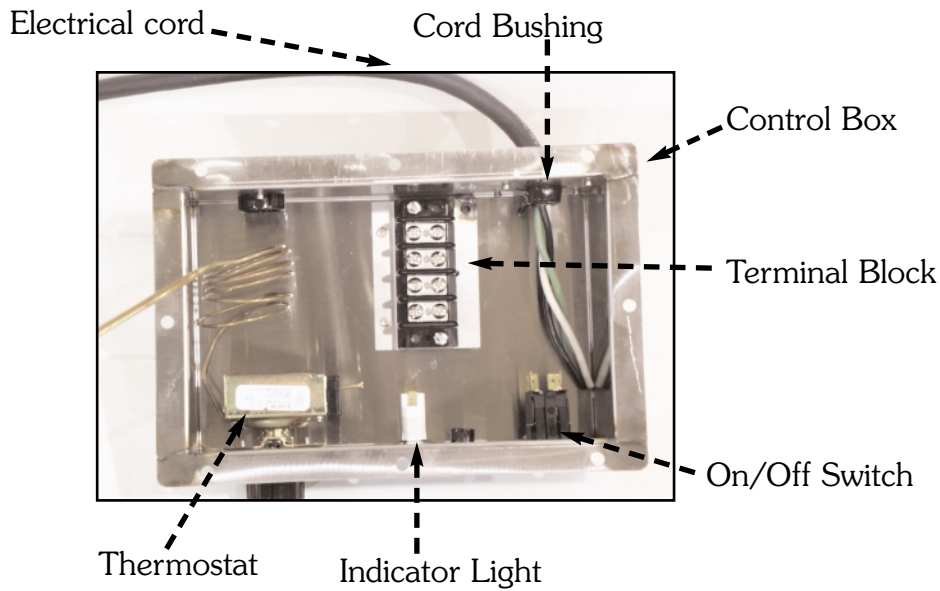
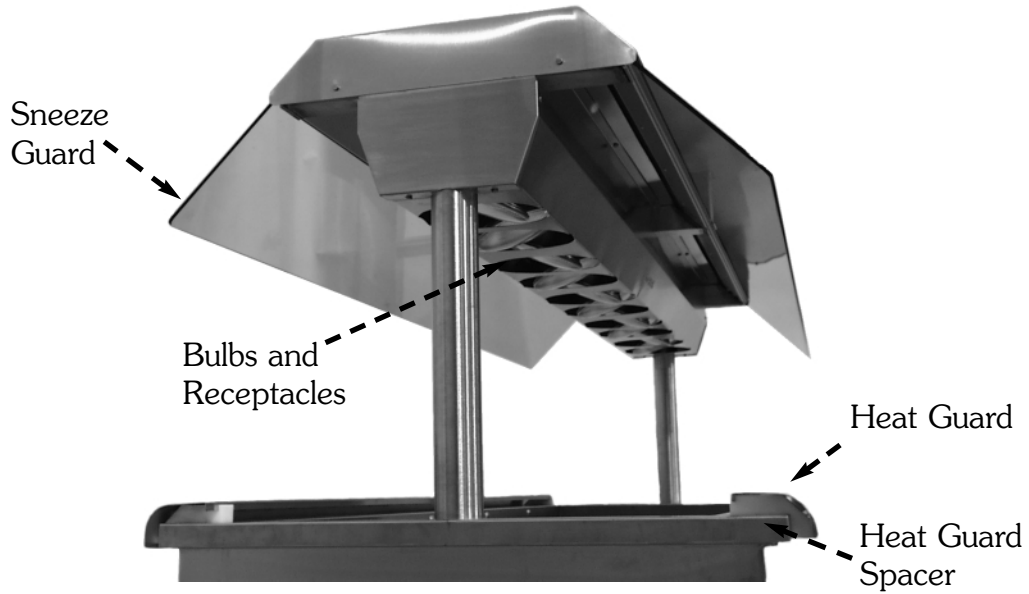

***Always disconnect unit from power source before cleaning or servicing.
If the power cord needs replacement, contact factory for exact replacement.
Use of any other cord may result in electrical or fire hazard.***

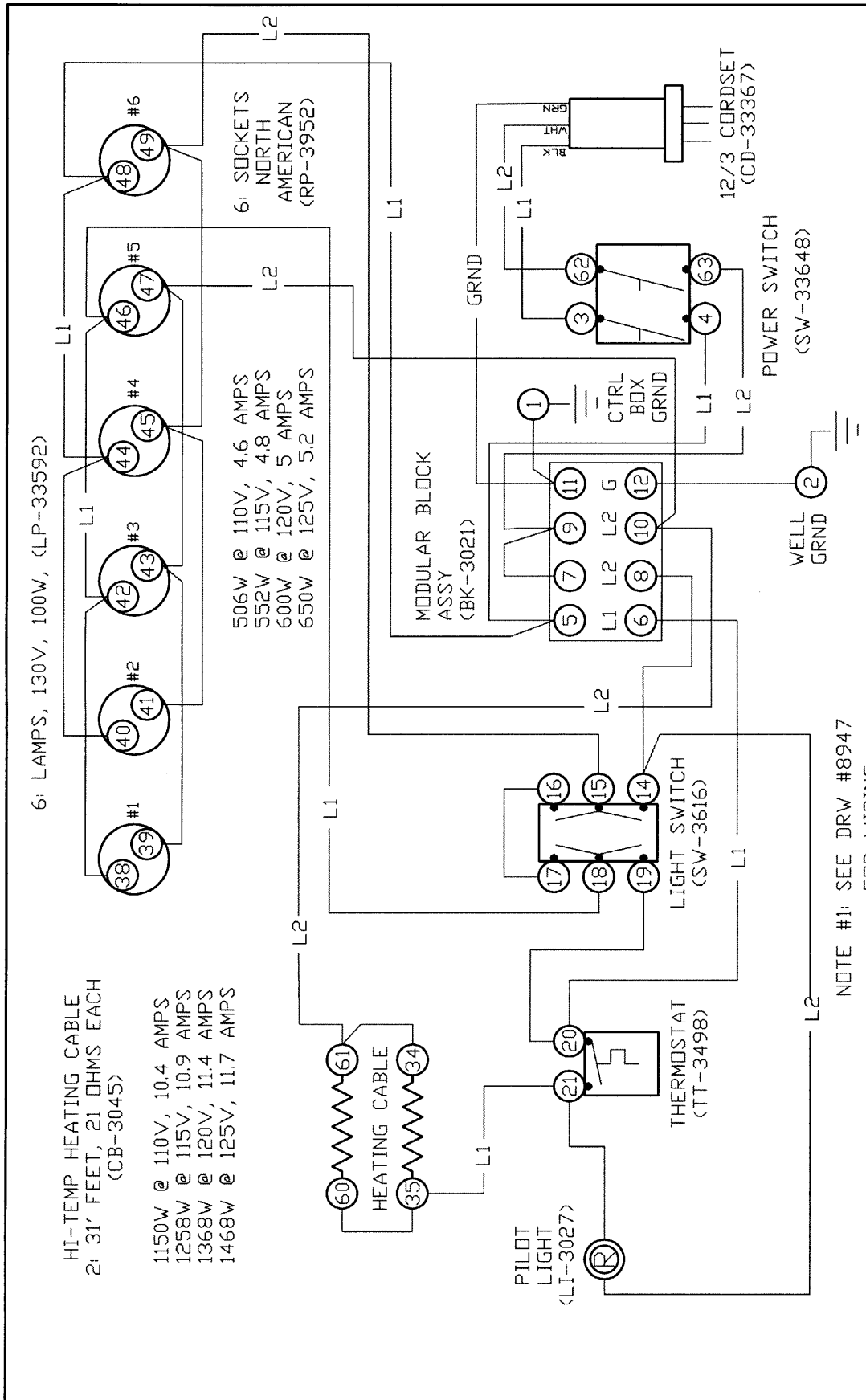

WIRING DIAGRAM

MODELS: 200-HFT, 125V

ALTO-SHAM
MENOMONEE FALLS, WISC. 53052-450

BY: N/W SCALE: NONE DWG: A-7539
APP'D: JRM DATE: 07/17/00

NOTE #1: SEE DRW #8947
FOR WIRING
ASSEMBLY DRAWING.

TOTAL POWER:

- 1650W @ 110V, 15.0 AMPS
- 1818W @ 115V, 15.8 AMPS
- 1968W @ 120V, 16.4 AMPS
- 2118W @ 125V, 16.9 AMPS

NO.	REVISION	BY
1	10/10/00	N/W
2	10/11/00	N/W
3	11/08/00	N/W
4	02/19/01	N/W

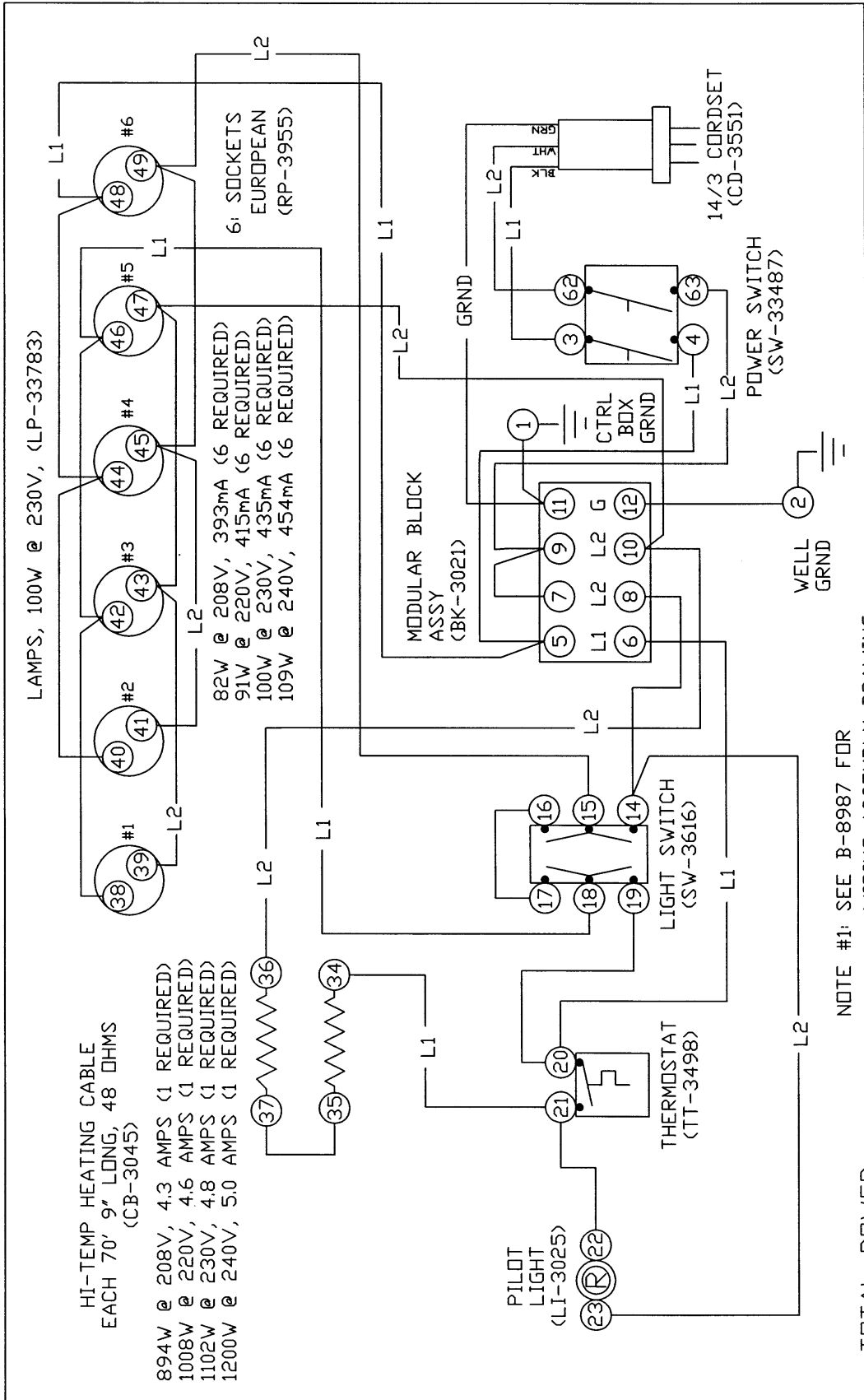

WIRING DIAGRAM

MODELS: 200-HFT, 208-240V, 50/60HZ

ALTO-SHAM®
MENOMONEE FALLS, WISC. 53052-450

NO	REVISION	BY	DATE	DWG:
1	09/17/02	CB		A-7566
2	05/03/04	CB		

BY: N/W SCALE: NONE
APP'D: JRM DATE: 11/10/00

NOTE #1: SEE B-8987 FOR WIRING ASSEMBLY DRAWING.

TOTAL POWER:

- 1386W @ 208V, 6.7 AMPS
- 1554W @ 220V, 7.1 AMPS
- 1704W @ 230V, 7.4 AMPS
- 1854W @ 240V, 7.7 AMPS

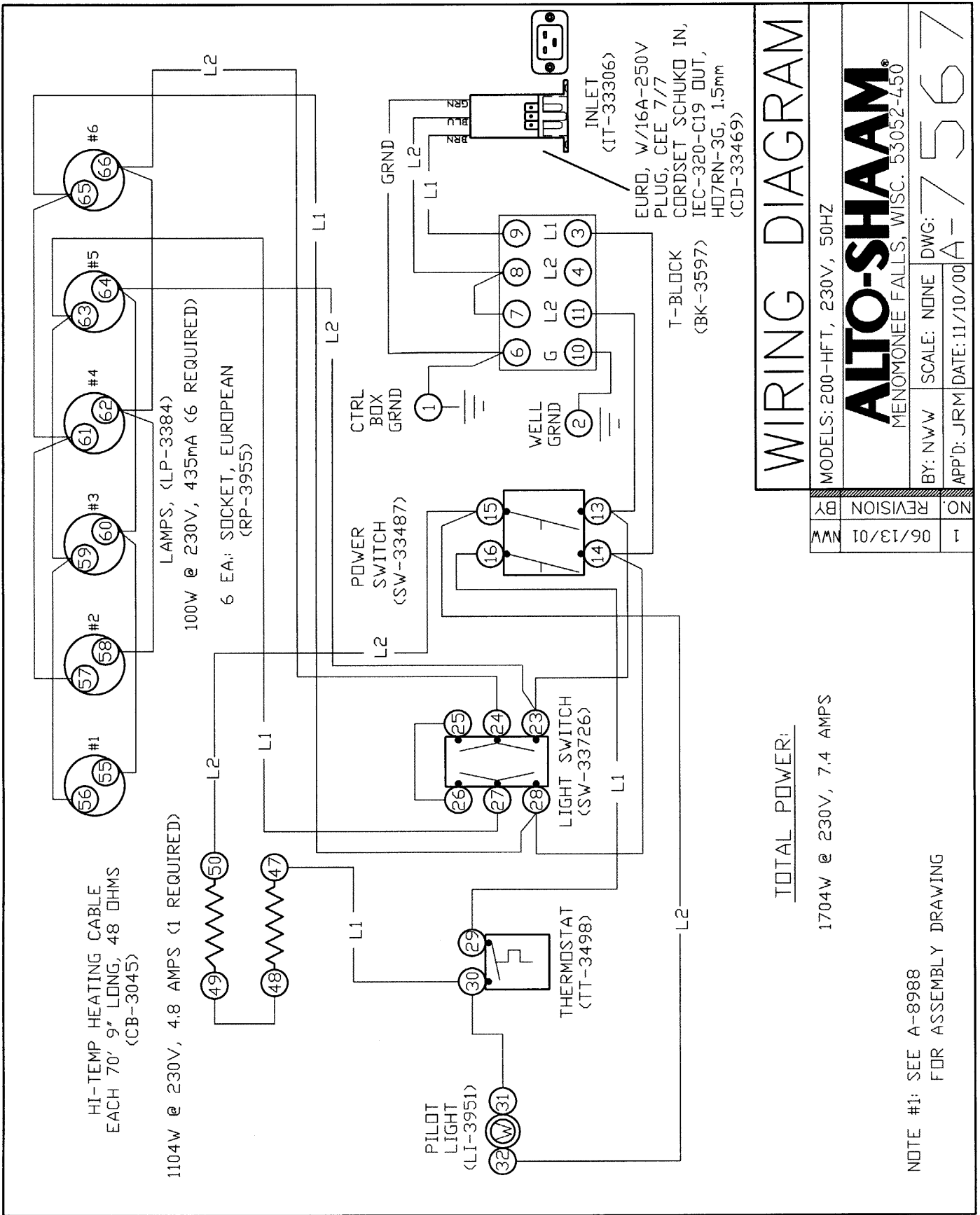

WIRING DIAGRAM

MODELS: 200-HFT, 230V, 50HZ

ALTO-SHAAM
MENOMONEE FALLS, WISC. 53052-450

NO.	REVISION	BY
1	06/13/01	NW

NOTE #1: SEE A-8988
FOR ASSEMBLY DRAWING

TOTAL POWER:

1704W @ 230V, 7.4 AMPS

BY: NW/W	SCALE: NONE	DWG: A-7567
APP'D: JRM	DATE: 11/10/00	

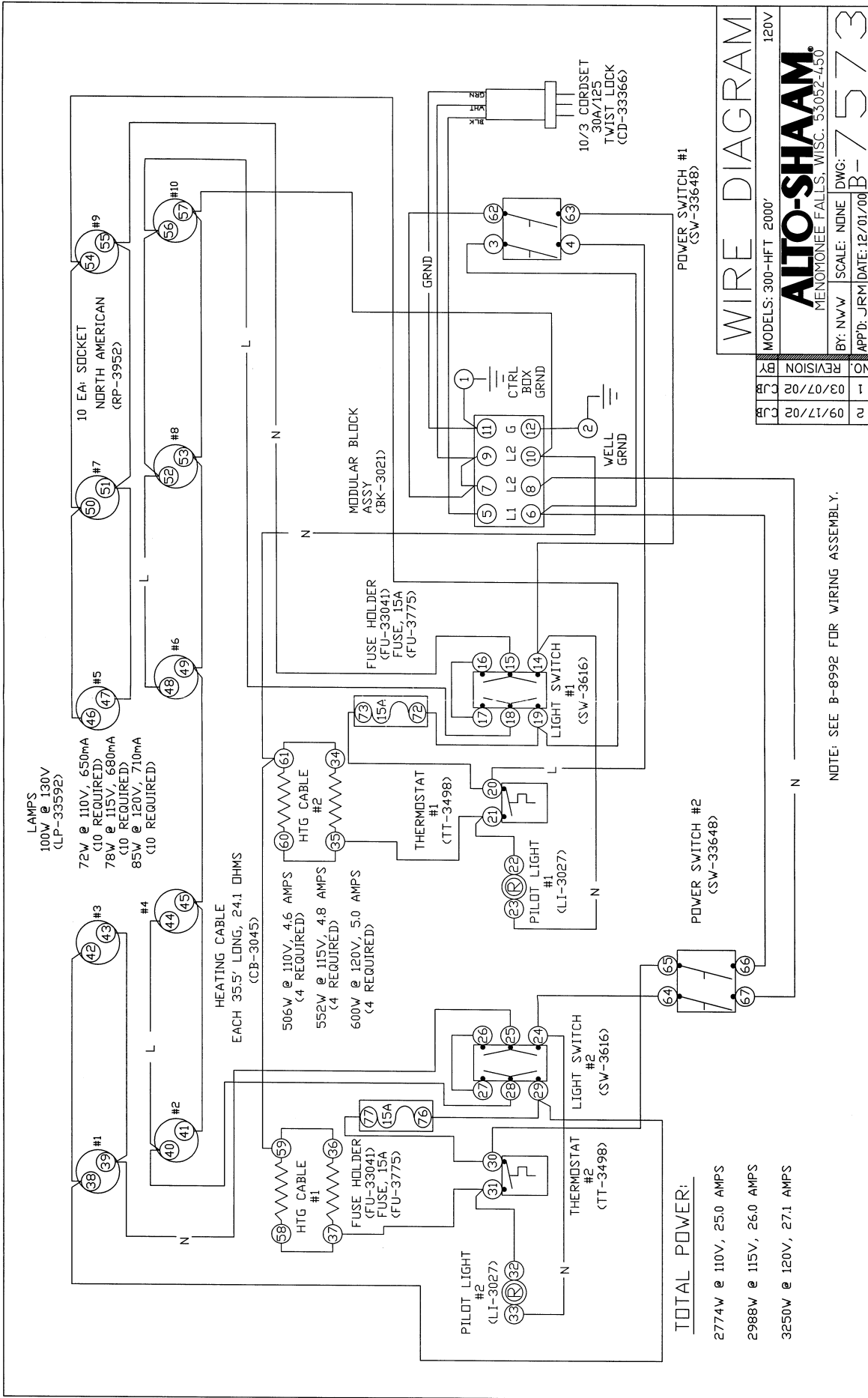

WIRE DIAGRAM

MODELS: 300-HFT 2000'		120V
ALTO-SHAAM		
MENDONREE FALLS, WISC. 53052-450		
BY: NAW	SCALE: NONE	DWG: B-7573
APP'D: JRM	DATE: 12/01/00	
NO. 2	REVISION 09/17/02	
BY: CJB	REVISION 03/07/02	

NOTE: SEE B-8992 FOR WIRING ASSEMBLY.

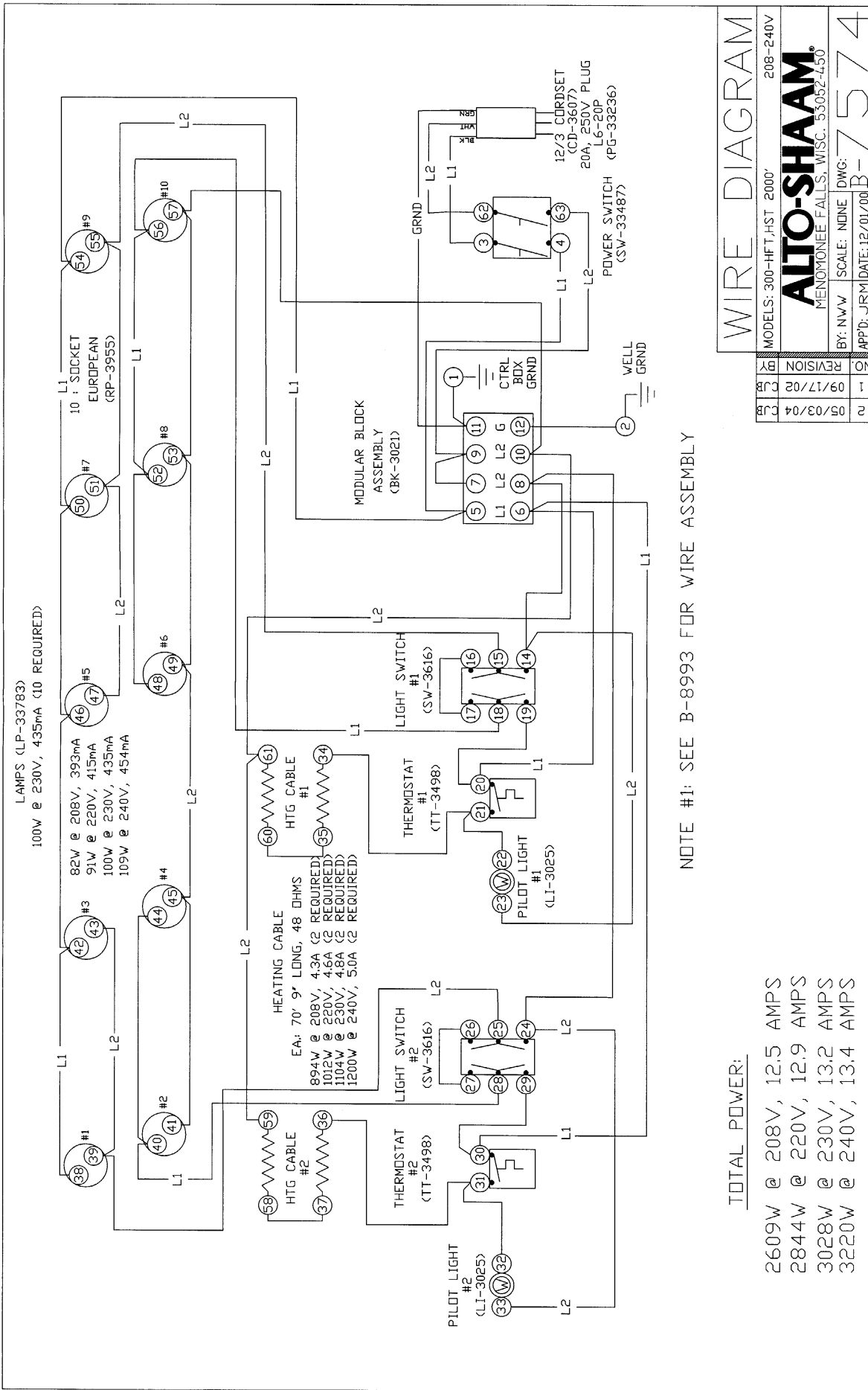

BY	REVISION	DATE	SCALE	DWG.
BR	1	09/17/02	NONE	B-7574
CB	2	05/03/04		

MODELS: 300-HFT_HST 2000' 208-240V
ALTO-SHAAM
 MENOMONEE FALLS, WISC. 53052-450
 APP'D: JRM DATE: 12/01/00

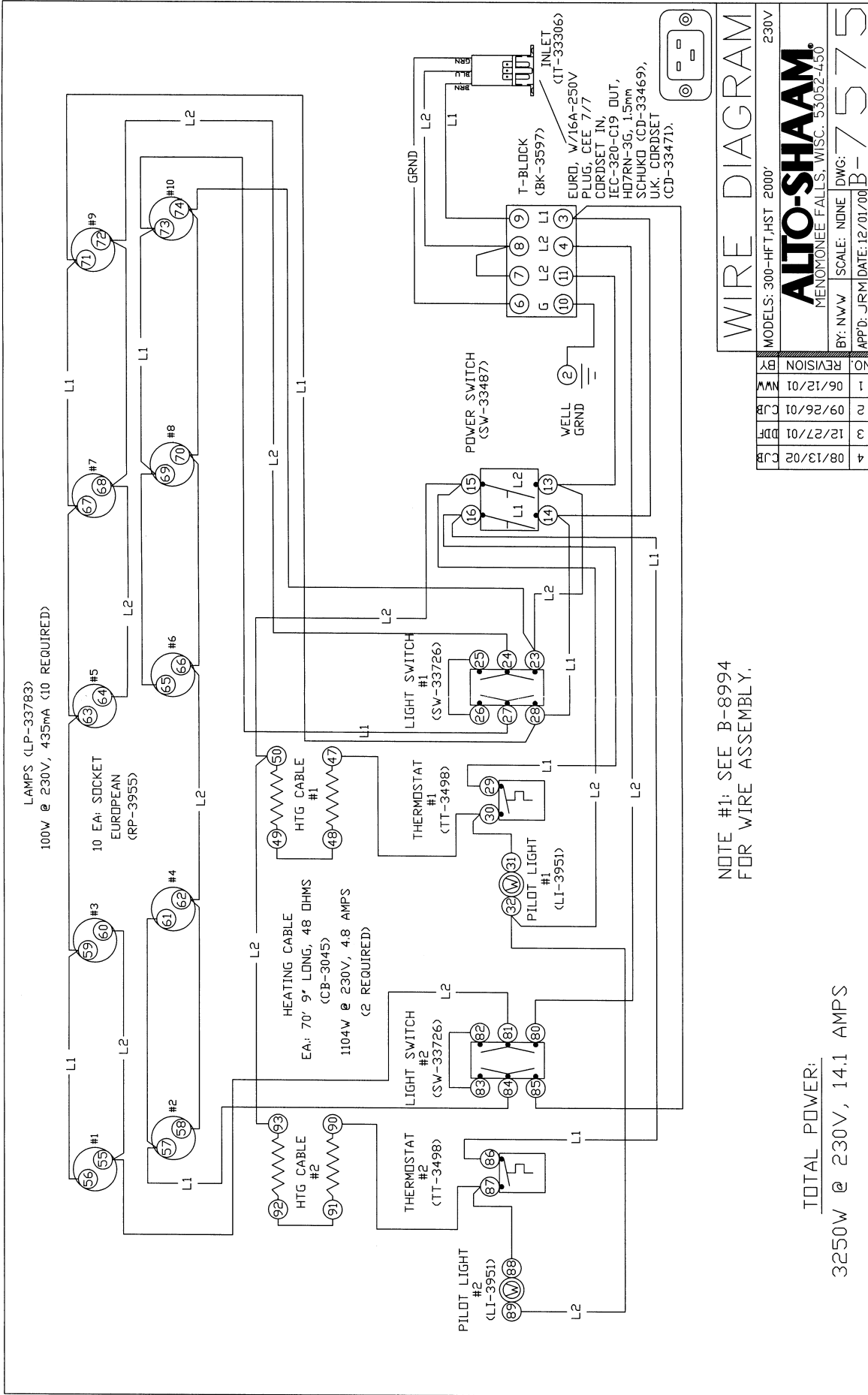

NOTE #1: SEE B-8994 FOR WIRE ASSEMBLY.

TOTAL POWER:
3250W @ 230V, 14.1 AMPS

HEATING CABLE

EA: 70' 9" LONG, 48 OHMS

894W @ 208V, 4.3A (1: REQUIRED)

1200W @ 240V, 5.0A (1: REQUIRED)

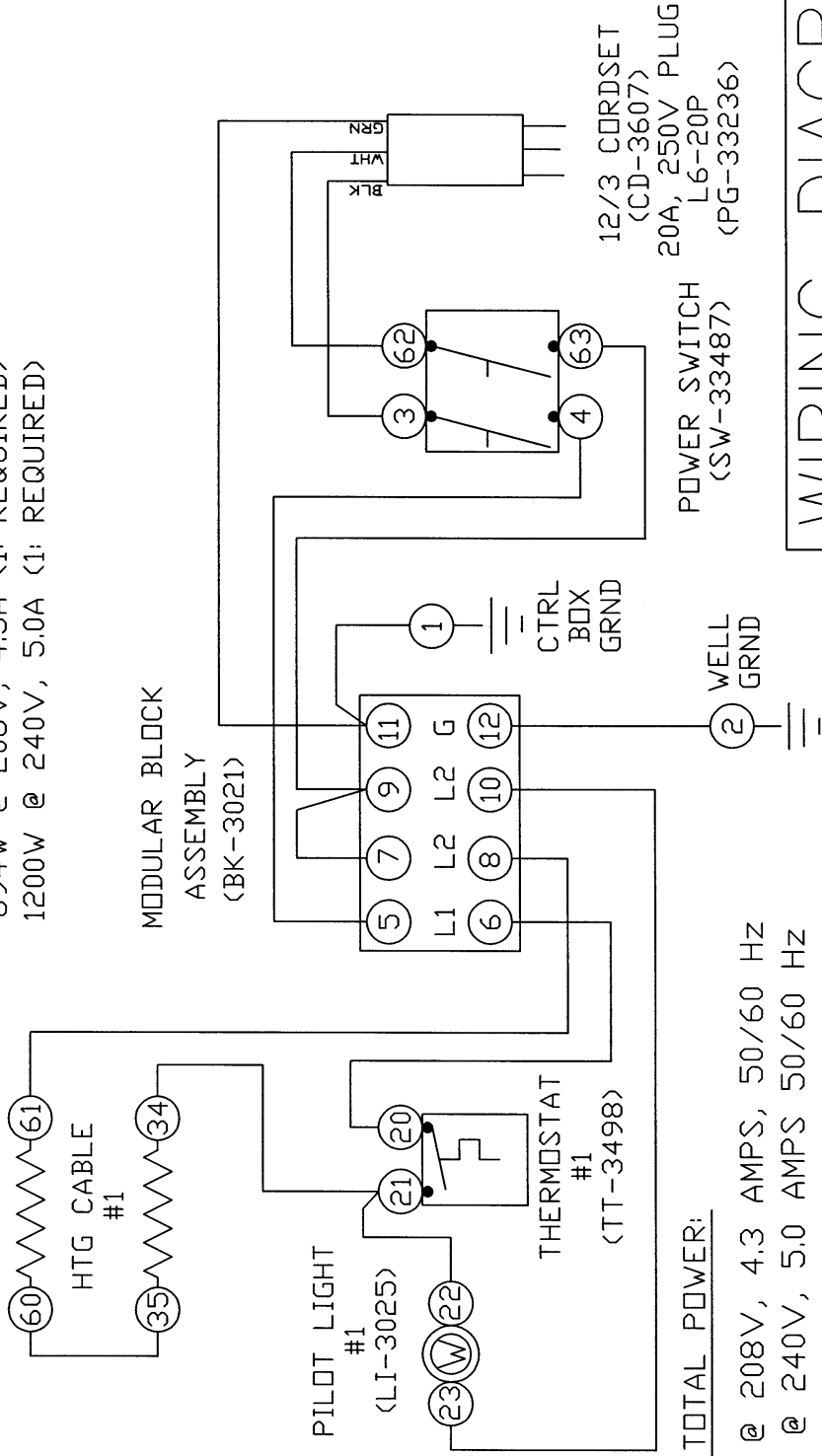

MODULAR BLOCK ASSEMBLY (BK-3021)

PILOT LIGHT #1 (LI-3025)

THERMOSTAT #1 (TT-3498)

TOTAL POWER:
 894W @ 208V, 4.3 AMPS, 50/60 HZ
 1200W @ 240V, 5.0 AMPS 50/60 HZ

WIRING DIAGRAM

MODELS: 200-HFT/BASE ONLY 208/240V

ALTO-SHAM®
 MENOMONEE FALLS, WISC. 53052-450

BY: AHL SCALE: 1"=1' DWG: 7697

APP'D: P.E.D DATE: 04/13/04 A-

HEATING CABLE
 EA: 70' 9" LONG, 48 OHMS
 894W @ 208V, 4.3A (2: REQUIRED)
 1200W @ 240V, 5.0A (2: REQUIRED)

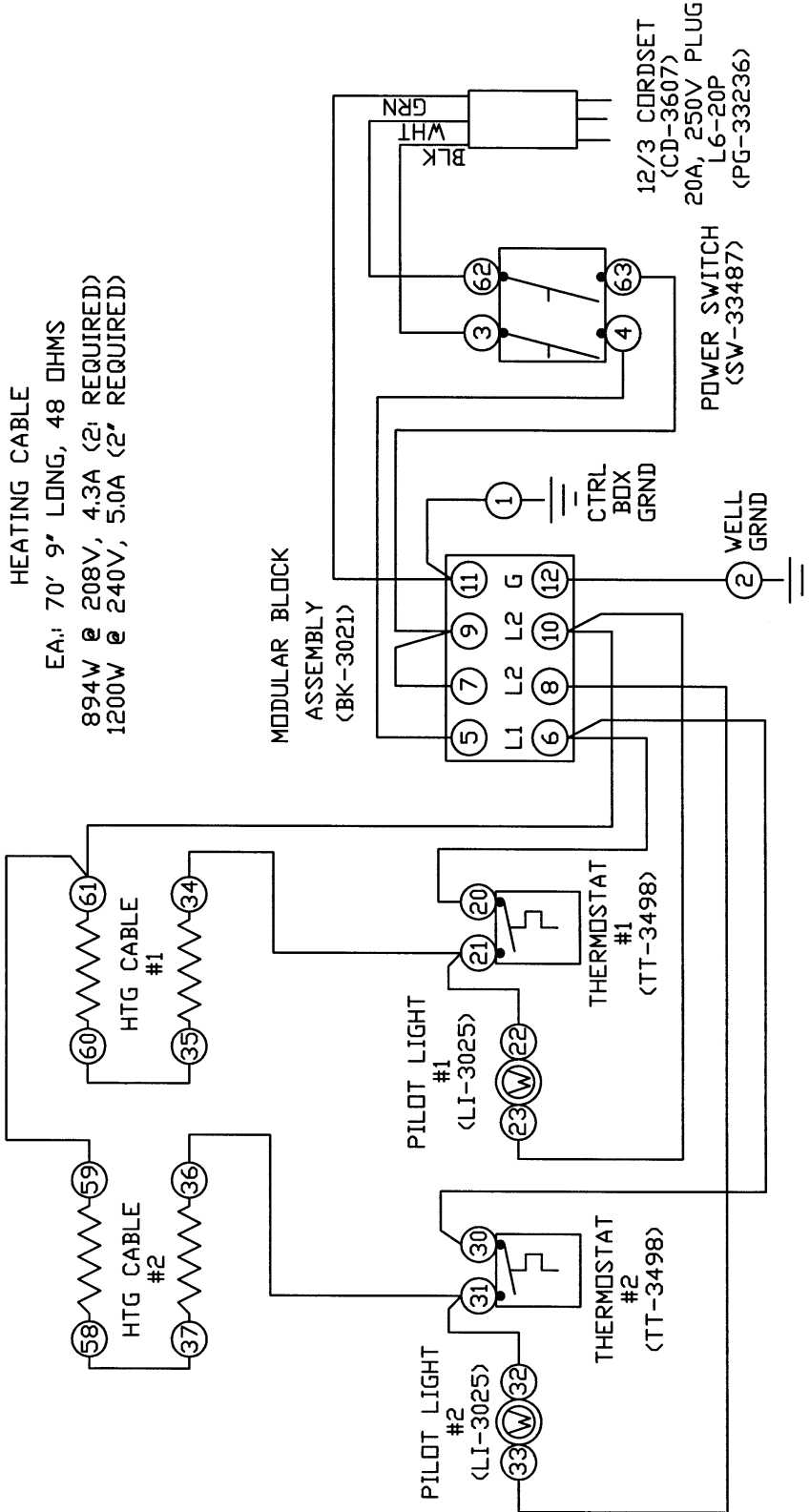

WIRING DIAGRAM

MODELS: 300-HFT/BASEONLY 208/240V

ALTO-SHAAM
 MENOMONEE FALLS, WISC. 53052-450

BY: AHL SCALE: 1"=1' DWG: 7698
 APP'D: PED DATE: 04/13/04 A-

TOTAL POWER:
 1788W @ 208V, 8.6 AMPS 50/60 Hz
 2400W @ 240V, 10.0 AMPS 50/60 Hz

TRANSPORTATION DAMAGE and CLAIMS



LIMITED WARRANTY



All Alto-Shaam equipment is sold F.O.B. shipping point, and when accepted by the carrier, such shipments become the property of the consignee.

Should damage occur in shipment, it is a matter between the carrier and the consignee. In such cases, the carrier is assumed to be responsible for the safe delivery of the merchandise, unless negligence can be established on the part of the shipper.

1. Make an immediate inspection while the equipment is still in the truck or immediately after it is moved to the receiving area. Do not wait until after the material is moved to a storage area.
2. Do not sign a delivery receipt or a freight bill until you have made a proper count and inspection of all merchandise received.
3. Note all damage to packages directly on the carrier's delivery receipt.
4. Make certain the driver signs this receipt. If he refuses to sign, make a notation of this refusal on the receipt.
5. If the driver refuses to allow inspection, write the following on the delivery receipt:
Driver refuses to allow inspection of containers for visible damage.
6. Telephone the carrier's office immediately upon finding damage, and request an inspection. Mail a written confirmation of the time, date, and the person called.
7. Save any packages and packing material for further inspection by the carrier.
8. Promptly file a written claim with the carrier and attach **copies** of all supporting paperwork.

We will continue our policy of assisting our customers in collecting claims which have been properly filed and actively pursued. We cannot, however, file any damage claims for you, assume the responsibility of any claims, or accept deductions in payment for such claims.

Alto-Shaam, Inc. warrants to the original purchaser that any original part that is found to be defective in material or workmanship will, at our option, subject to provisions hereinafter stated, be replaced with a new or rebuilt part.

The labor warranty remains in effect one (1) year from installation or fifteen (15) months from the shipping date, whichever occurs first.

The parts warranty remains in effect one (1) year from installation or fifteen (15) months from the shipping date, whichever occurs first.

Exceptions to the one year part warranty period are as listed:

- A. Halo Heat cook/hold ovens include a five (5) year parts warranty on the heating element. Labor will be covered under the terms of the standard warranty period of one (1) year or fifteen (15) months.
- B. Alto-Shaam Quickchillers include a five (5) year parts warranty on the refrigeration compressor. Labor will be covered under the terms of the standard warranty period of one (1) year or fifteen (15) months.

This warranty does not apply to:

1. Calibration
2. Replacement of light bulbs and/or the replacement of display case glass due to damage of any kind.
3. Equipment damage caused by accident, shipping, improper installation or alteration.
4. Equipment used under conditions of abuse, misuse, carelessness or abnormal conditions.
5. Any losses or damage resulting from malfunction, including loss of product or consequential or incidental damages of any kind.
6. Equipment modified in any manner from original model, substitution of parts other than factory authorized parts, removal of any parts including legs, or addition of any parts.

This warranty is exclusive and is in lieu of all other warranties, expressed or implied, including the implied warranties of merchantability and fitness for purpose. In no event shall the Company be liable for loss of use, loss of revenue, or loss of product or profit, or for indirect or consequential damages. This warranty is in lieu of all other warranties expressed or implied and Alto-Shaam, Inc. neither assumes or authorizes any persons to assume for it any other obligation or liability in connection with Alto-Shaam equipment.

ALTO-SHAAM, INC.

Warranty effective January 1, 2000

RECORD THE MODEL AND SERIAL NUMBERS OF THE UNIT FOR EASY REFERENCE.

ALWAYS REFER TO BOTH MODEL AND SERIAL NUMBER IN ANY CONTACT WITH ALTO-SHAAM REGARDING THE UNIT.

Model Number: _____
Voltage: _____
Serial Number: _____

Date Installed: _____
Purchased from: _____

W164 N9221 Water Street • P.O. Box 450 • Menomonee Falls, Wisconsin 53052-0450 • U.S.A.

PHONE: 262.251.3800

FAX: 262.251.7067 • 800.329.8744 U.S.A./CANADA

WEBSITE:

800.558.8744 U.S.A./CANADA

262.251.1907 INTERNATIONAL

www.alto-shaam.com