



100-CW



300-CW



500-CW

100-CW

200-CW

300-CW

400-CW

500-CW

600-CW

- **Installation**
- **Operation**
- **Maintenance**

W164 N9221 Water Street • P.O. Box 450
Menomonee Falls, Wisconsin 53052-0450 U.S.A.

PHONE: 262.251.3800 • 800.558.8744 U.S.A. / CANADA
FAX: 262.251.7067 • 800.329.8744 U.S.A. ONLY
www.alto-shaam.com

Printed in the U.S.A.



Consult instructions
for operation and use.



MN-36033 (Rev 6) • 08/25

Copyright

© Copyright 10/25 by Alto-Shaam, Inc.

All rights reserved.

This manual or any portion thereof may not be reproduced or used in any manner whatsoever without the express written permission of Alto-Shaam, Inc.

Trademarks

All trademarks referenced in this documentation are the property of their respective owners.

Manufacturer

Alto-Shaam, Inc.
P.O. Box 450
W164 N9221 Water Street
Menomonee Falls, WI 53052

Original Instructions

The content in this manual is written in American English.

Service Parts

Interactive parts diagrams for this appliance are available online using our Parts Finder Tool:
<https://www.alto-shaam.com/en/customer-support/parts>.
Or, scan the QR code below.



Manufacturers Information	2
Table of Contents	3
Register the Appliance	4
Delivery	5
Unpacking	6
Safety Precautions	8
Labels	9
Dimensions	10
Installation	13
Plumbing Installation	17
Installation Checklist	18
Operation	19
Food Safety	21
Cleaning and Preventative Maintenance	22
Troubleshooting	24
Limited Warranty	25
Wire Diagram	26

Enjoy your Alto-Shaam Drop-In Refrigerated Cold Well!

Drop-in Cold Well The Alto-Shaam Cold Well uses proven cold wall conductive cooling that doesn't blow air over the top of the food, so your food stays moist and appealing for hours. Less waste, lower food costs, and more sales means that more money goes back to your bottom line.

Extend Your Manufacturer's Warranty

Register Registering your appliance ensures prompt service in the event of a warranty claim. You will also receive direct notifications of software updates and additional product information.

Your personal information will not be shared with any other company.

www.alto-shaam.com/warranty

Alto-Shaam 24/7 Emergency Repair Service

Call Call 800-558-8744 to reach our 24-hour emergency service call center for immediate access to local authorized service agencies outside standard business hours. The emergency service access is provided exclusively for Alto-Shaam equipment and is available throughout the United States through Alto-Shaam's toll free number.

Availability Emergency service access is available seven days a week, including holidays.

This Alto-Shaam appliance has been thoroughly tested and inspected to ensure only the highest quality appliance is provided. Upon receipt, check for any possible shipping damage and report it at once to the delivering carrier.

This appliance, including unattached items and accessories, may be delivered in one or more packages. Ensure all standard items and options have been received with each appliance as ordered. Save all the information packed with the appliance. Register the appliance online at www.alto-shaam.com/en/support/warranty-registration to ensure prompt service in the event of a warranty parts and labor claim.

This manual must be read and understood by all people using or installing the appliance. Contact the Alto-Shaam Tech Team Service Department if you have any questions concerning installation, operation, or maintenance.

1-800-558-8744; servicedept@alto-shaam.com

The serial number is required for all inquiries.
 Always include both model and serial number(s) in any correspondence regarding the appliance.

Model: _____
 Serial number: _____
 Purchased from: _____
 Date installed: _____ Voltage: _____

CAUTION

Appliance and accessories may be heavy. To prevent serious injury, always use a sufficient number of trained and experienced workers when moving or leveling appliance and handling accessories.

Environmental Conditions

- Operational Environmental Conditions
- Before use, appliance must acclimate to room temperature in the environment it is placed — 24 hours is recommended.
 - Ambient temperature range of 60°F to 110°F (16°C to 43°C).
 - Relative humidity of less than 95% non-condensation.
 - Atmospheric pressure range of 17.7" to 31.3" of mercury (50kPa to 106kPa).

Record the model and serial number of the appliance for easy reference. Always refer to both model and serial number in any contact with Alto-Shaam regarding this appliance.

Model: _____
 Serial Number: _____
 Date Installed: _____
 Voltage: _____
 Purchased From: _____



Alto-Shaam has established a twenty-four hour emergency service call center to offer immediate customer access to a local authorized service agency outside of standard business hours. The emergency service access is provided exclusively for Alto-Shaam equipment and is available throughout the United States through the use of Alto-Shaam's toll-free number. Emergency service access is available seven days a week including holidays.

- Carefully remove the appliance from the carton or crate.
NOTE: Do not discard the carton and other packaging material until you have inspected the appliance for hidden damage and tested it for proper operation.
- Remove all protective plastic film, packaging materials, and accessories from the appliance before connecting electrical power. Store any accessories in a convenient place for future use.

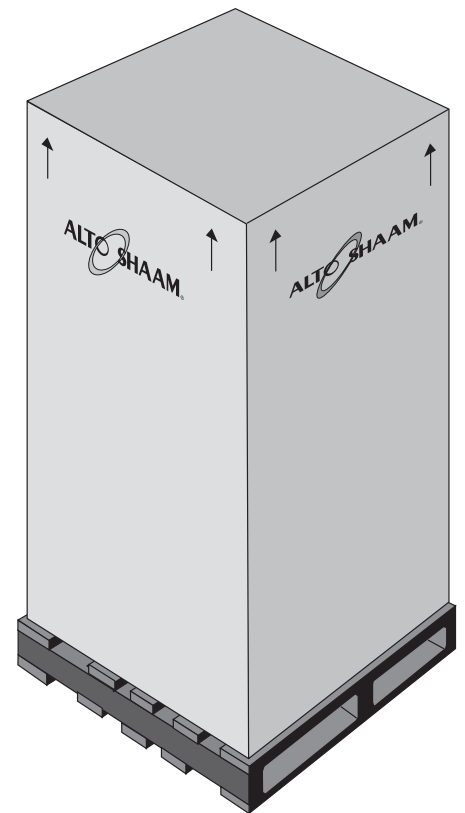

- The appliance is intended for use in commercial establishments only, and is intended to hold previously prepared food for human consumption. Food is to be held cold. No other use for this appliance is authorized by the manufacturer or its agents and is therefore considered dangerous.
- The appliance is intended for use in commercial establishments where all operators are familiar with the purpose, limitations, and associated hazards of this appliance. Operating instructions and warnings must be read and understood by all operators and users. Alto-Shaam recommends regular staff training to avoid the risk of accident or damage to the appliance. Operators must also receive regular safety instructions.
- Any troubleshooting guides, component views, and parts lists included in this manual are for general reference only and are intended for use by qualified and trained technicians.
- This manual should be considered a permanent part of this appliance. This manual and all supplied instructions, diagrams, schematics, parts lists, notices, and labels must remain with the appliance if the item is sold or moved to another location.



NOTICE: For equipment delivered for use in any location regulated by the following directive: 2012/19/EU WEEE

Do not dispose of electrical or electronic equipment with other municipal waste.

Knowledge of proper procedures is essential to the safe operation of electrically and/or gas energized equipment. The following signal words and symbols may be used throughout this manual.

⚠ DANGER

Indicates a hazardous situation that, if not avoided, will result in death or serious injury.

⚠ WARNING

Indicates a hazardous situation that, if not avoided, could result in death or serious injury.

⚠ CAUTION

Indicates a hazardous situation that, if not avoided, could result in minor or moderate injury.

NOTICE: Indicates information considered important, but not hazard-related (e.g., messages relating



Indicates that referral to operating instructions is recommended to understand operation of equipment.

- To prevent serious injury, death or property damage, the appliance should be inspected and serviced at least every twelve (12) months by an authorized service partner or trained technician.
- **Only** allow an authorized service partner or trained technician to service or to repair the appliance. Installation or repairs that are not performed by an authorized service partner or trained technician, or the use of non-factory authorized parts, will void the warranty and relieve Alto-Shaam of all liability.
- When working on this appliance, observe precautions in the literature, on tags, on labels attached to or shipped with the appliance and other safety precautions that may apply.
- This appliance is not intended for use by persons (including children) with reduced physical, sensory or mental capabilities, or lack of experience and knowledge, unless they have been given supervision concerning use of the appliance by person responsible for their safety.
- Children should be supervised to ensure that they do not play with the appliance.
- Only operate the appliance with pans installed to avoid possible equipment damage.

WARNING	
	<p>This appliance is not intended for use by persons (including children) with reduced physical, sensory or mental capabilities, or lack of experience and knowledge, unless they have been given supervision concerning use of the appliance by person responsible for their safety.</p> <p>Children should be supervised to ensure that they do not play with the appliance.</p>

- CAUTION:** THIS UNIT CONTAINS R290 FLAMMABLE REFRIGERANT. SEE ABOVE CAUTION.
- CAUTION:** UNIT MUST BE INSTALLED INTO ITS OWN COMPARTMENT TO PROPERLY CONTAIN ANY REFRIGERANT LEAK. IT IS REQUIRED THAT NO ARCHING POTENTIAL COMPONENTS (GFCI) OR ELECTRICAL CONNECTIONS ARE BELOW 14.5" FROM THE BOTTOM OF THE CABINET.
- WARNING:** FAILURE TO FOLLOW INSTALLATION GUIDELINES AND RECOMMENDATIONS MAY VOID THE WARRANTY ON YOUR UNIT.
- WARNING:** IT IS IMPORTANT THAT YOUR UNIT HAS ITS OWN DEDICATED LINE. CONDENSING UNITS ARE DESIGNED TO OPERATE WITH A VOLTAGE FLUCTUATION OF PLUS OR MINUS 10% OF THE VOLTAGE INDICATED ON THE UNIT DATA TAG. BURN OUT OF A CONDENSING UNIT DUE TO EXCEEDING VOLTAGE LIMITS WILL VOID THE WARRANTY
- WARNING:** IT IS IMPORTANT THAT A VOLTAGE READING BE MADE AT THE COMPRESSOR MOTOR ELECTRICAL CONNECTIONS WHILE THE UNIT IS IN OPERATION TO VERIFY THE CORRECT VOLTAGE REQUIRED BY THE COMPRESSOR IS BEING SUPPLIED. LOW OR HIGH VOLTAGE CAN DETRIMENTALLY AFFECT OPERATION AND THEREBY VOID ITS WARRANTY.

Safety Precautions for Flammable Refrigerants (290)

	<p>WARNING: Fire or Explosion hazard. Only trained personnel shall service equipment that uses flammable refrigerants.</p>
---	---

R290 refrigerant is highly pure propane. R290 refrigerant is flammable. Obey the following when installing, maintaining, or servicing equipment that uses R290 refrigerant.

- Do not smoke.
- Do not puncture refrigerant tubing.
- Do not use mechanical means to defrost the appliance.
- Remove sources of ignition from the area.
- Work only when the area is well-ventilated.
- Use a combustible gas detector when checking for leaks.
- Have a fire extinguisher nearby.
- Follow the appropriate authority's regulations for charge pressure. The use of flammable gases is currently limited, according to the standards EN378-1, EN60335-2-24 and EN60335-2-89, for fluid charges of 150g on hermetically sealed devices

Locate on interior evaporator cover

 <b style="font-size: 24pt;">DANGER	<p>RISQUE D'INCENDIE OU D'EXPLOSION. INFLAMMABLE RÉFRIGÉRANT UTILISÉ. NE PAS UTILISER DE DISPOSITIFS MÉCANIQUES POUR DÉGIVRER LE RÉFRIGÉRATEUR. NE FAIRE AUCUN TUBE RÉFRIGÉRANT DE PONCTION.</p> <p style="font-size: 8pt;">SB6.1.2</p>	<b style="font-size: 18pt;">WARNING  <b style="font-size: 18pt;">ALERTE
<p>RISK OF FIRE OR EXPLOSION. FLAMMABLE REFRIGERANT USED. DO NOT USE MECHANICAL DEVICES TO DEFROST REFRIGERATOR. DO NOT PUNCTURE REFRIGERANT TUBING.</p>		<b style="font-size: 18pt;">CAUTION  <b style="font-size: 18pt;">ATTENTION
<p>RIESGO DE INCENDIO O EXPLOSIÓN. REFRIGERANTE INFLAMABLE UTILIZADO. NO UTILICE DISPOSITIVOS MECÁNICOS PARA DESCONGELAR EL REFRIGERADOR. NO PERFORE LA TUBERÍA DEL REFRIGERANTE.</p> <p style="font-size: 8pt;">PP LBL1701 REV B</p>		<p>DO NOT REMOVE PANEL - HIGH VOLTAGE - QUALIFIED PERSONNEL ONLY NE PAS RETIRE LE PANNEAU - HAUTE TENSION - PERSONNEL QUALIFIÉ SEULEMENT NO RETIRE EL PANEL - ALTA TENSION - CALIFICADO PERSONAL</p> <p>MOVING PARTS, DO NOT OPERATE WITH COVER REMOVED PIÈCES MOBILES NE PAS FAIRE FONCTIONNER SANS COUVERCLE LAS PIEZAS DE MOVIMIENTO NO FUNCIONAN CON LA CUBIERTA RETIRADA</p>



Located on exterior of unit

 <b style="font-size: 24pt;">CAUTION	<p>MISE EN GARDE RISQUE D'INCENDIE OU D'EXPLOSION. ÉLIMINER (or DISPOSER) CORRECTEMENT CONFORMÉMENT AUX RÉGLEMENTATIONS FÉDÉRALES OU LOCALES. RÉFRIGÉRANT INFLAMMABLE UTILISÉ.</p> <p style="font-size: 8pt;">PP LBL1704 REV B</p>
<p>RISK OF FIRE OR EXPLOSION. DISPOSE OF PROPERLY IN ACCORDANCE WITH FEDERAL OR LOCAL REGULATIONS. FLAMMABLE REFRIGERANT USED.</p>	
<p>PRECAUCIÓN RIESGO DE INCENDIO O EXPLOSIÓN. DESÉCHELO ADECUADAMENTE CONFORME</p> <p style="font-size: 8pt;">SB6.1.4</p>	

Located near exposed refrigerant tubing

 <b style="font-size: 24pt;">CAUTION	<p>MISE EN GARDE RISQUE D'INCENDIE OU D'EXPLOSION EN RAISON DE LA PERFORATION DU TUBE RÉFRIGÉRANT; SUIVEZ ATTENTIVEMENT LES INSTRUCTIONS DE MANIPULATION. RÉFRIGÉRANT INFLAMMABLE UTILISÉ.</p>
<p>RISK OF FIRE OR EXPLOSION DUE TO PUNCTURE OF REFRIGERANT TUBING; FOLLOW HANDLING INSTRUCTIONS CAREFULLY. FLAMMABLE REFRIGERANT USED.</p>	
<p>PRECAUCIÓN RIESGO DE INCENDIO O EXPLOSIÓN DEBIDO A LA PERFORACIÓN DE LA TUBERÍA DE REFRIGERANTE. SIGA CUIDADOSAMENTE LAS INSTRUCCIONES DE MANEJO. REFRIGERANTE INFLAMABLE UTILIZADO.</p> <p style="font-size: 8pt;">SB6.1.5 PP LBL1705 REV B</p>	

Located near machine compartment and nameplate

 <b style="font-size: 24pt;">DANGER	<p>DANGER RISQUE D'INCENDIE OU D'EXPLOSION. RÉFRIGÉRANT INFLAMMABLE UTILISÉ. POUR ÊTRE RÉPARÉ QUE PAR UN TECHNICIEN QUALIFIÉ. NE PAS PERFORER LE TUBE RÉFRIGÉRANT.</p>
<p>RISK OF FIRE OR EXPLOSION. FLAMMABLE REFRIGERANT USED. TO BE REPAIRED ONLY BY TRAINED SERVICE PERSONNEL. DO NOT PUNCTURE REFRIGERANT TUBING.</p>	
<p>PELIGRO RIESGO DE INCENDIO O EXPLOSIÓN. REFRIGERANTE INFLAMABLE UTILIZADO. DEBE SER REPARADO SOLAMENTE POR PERSONAL DE SERVICIO CAPACITADO. NO PERFORE LA TUBERÍA DEL REFRIGERANTE.</p> <p style="font-size: 8pt;">SB6.1.3.a</p>	
 <b style="font-size: 24pt;">CAUTION	<p>MISE EN GARDE RISQUE D'INCENDIE OU D'EXPLOSION. RÉFRIGÉRANT INFLAMMABLE UTILISÉ. CONSULTER LE MANUEL DE RÉPARATION / GUIDE DE L'UTILISATEUR AVANT D'ESSAYER D'INSTALLER OU DE RÉPARER CE PRODUIT. TOUTES LES PRÉCAUTIONS DOIVENT ÊTRE RESPECTÉES.</p> <p style="font-size: 8pt;">PP LBL1703 REV B</p>
<p>RISK OF FIRE OR EXPLOSION. FLAMMABLE REFRIGERANT USED. CONSULT REPAIR MANUAL / OWNER'S GUIDE BEFORE ATTEMPTING TO INSTALL OR SERVICE THIS PRODUCT. ALL SAFETY PRECAUTIONS MUST BE FOLLOWED.</p>	
<p>PRECAUCIÓN RIESGO DE INCENDIO O EXPLOSIÓN. REFRIGERANTE INFLAMABLE UTILIZADO. CONSULTE EL MANUAL DE REPARACIÓN / MANUAL DEL USUARIO ANTES DE INSTALAR O REPARAR ESTE PRODUCTO. DEBEN SEGUIRSE LAS PRECAUCIONES DE SEGURIDAD.</p> <p style="font-size: 8pt;">SB6.1.3.b</p>	

100-CW

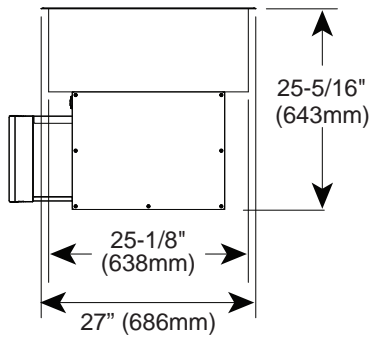
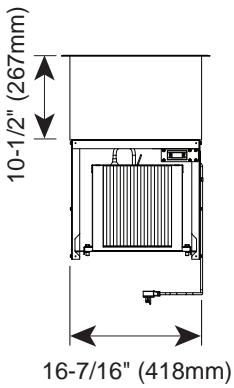
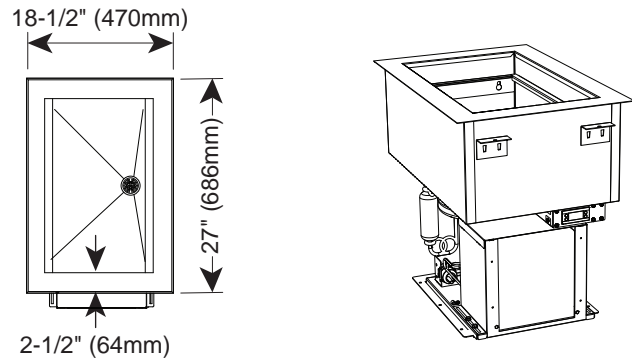

200-CW

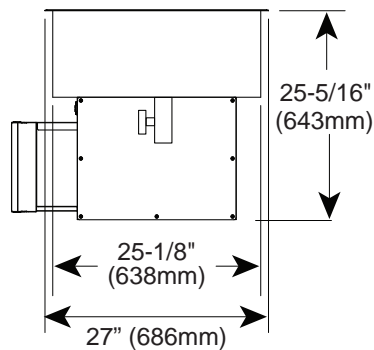
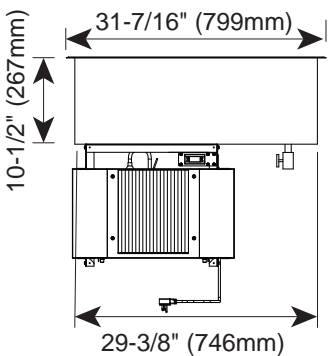
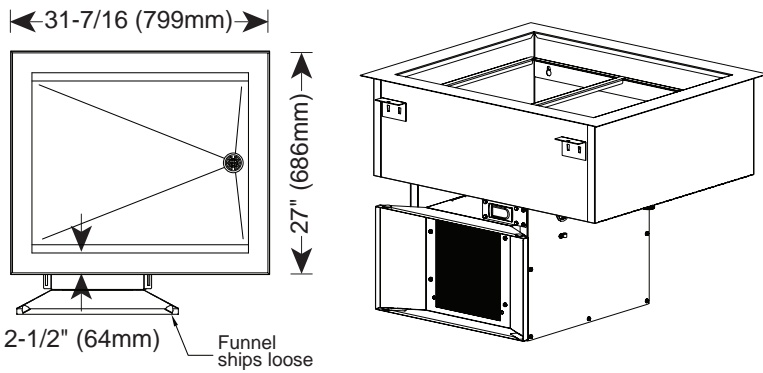

300-CW

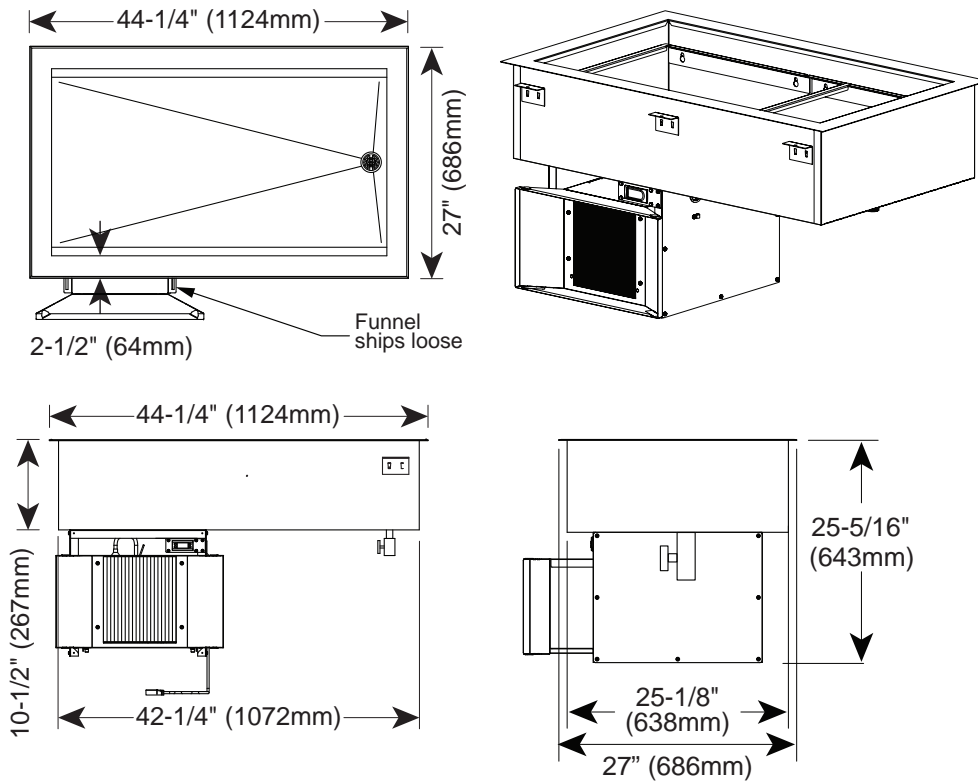

400-CW

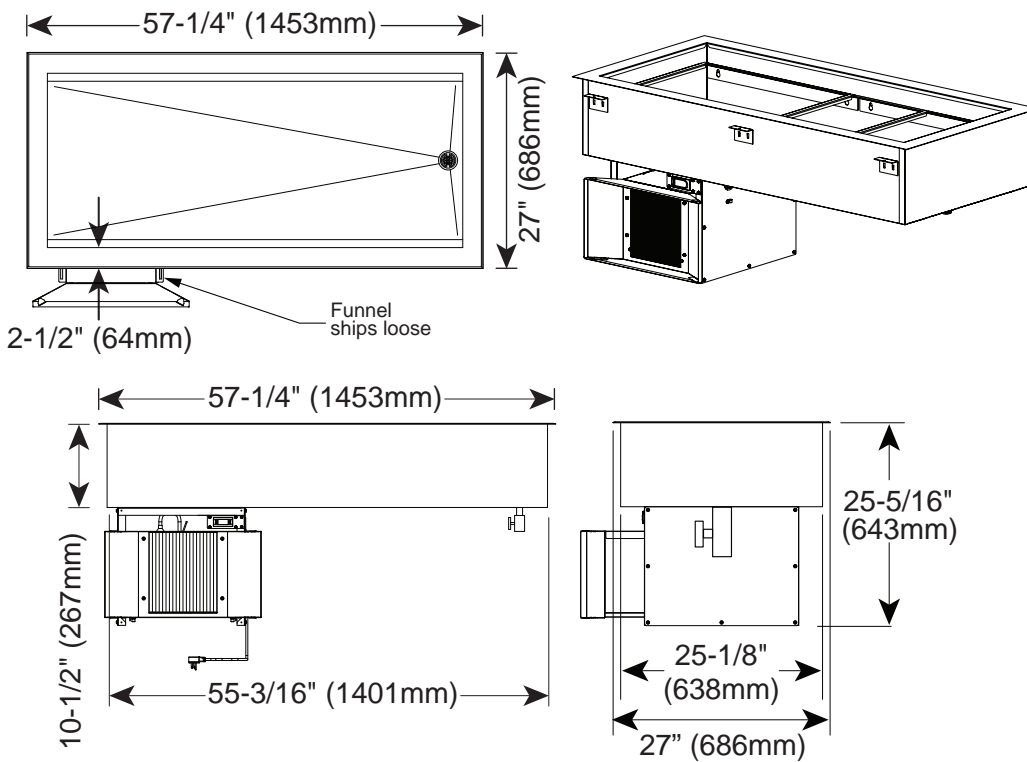

Dimensions

500-CW

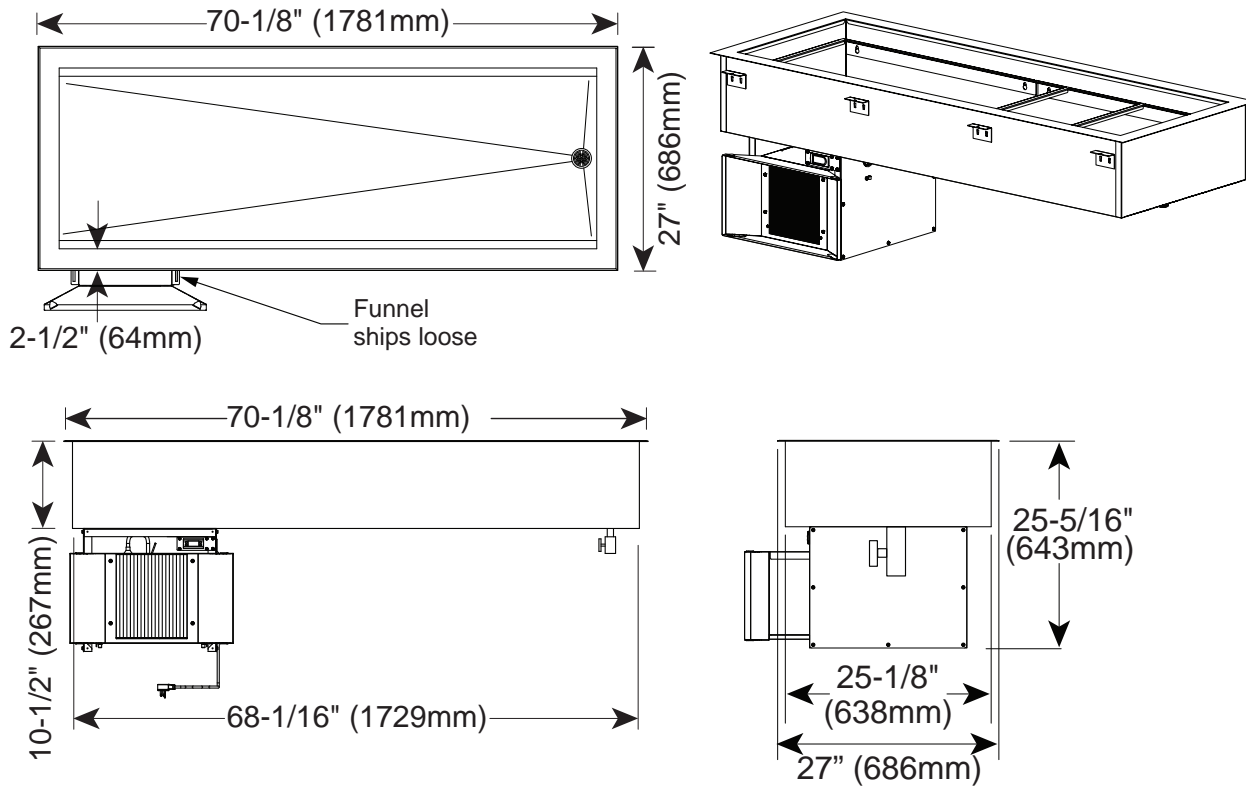

600-CW

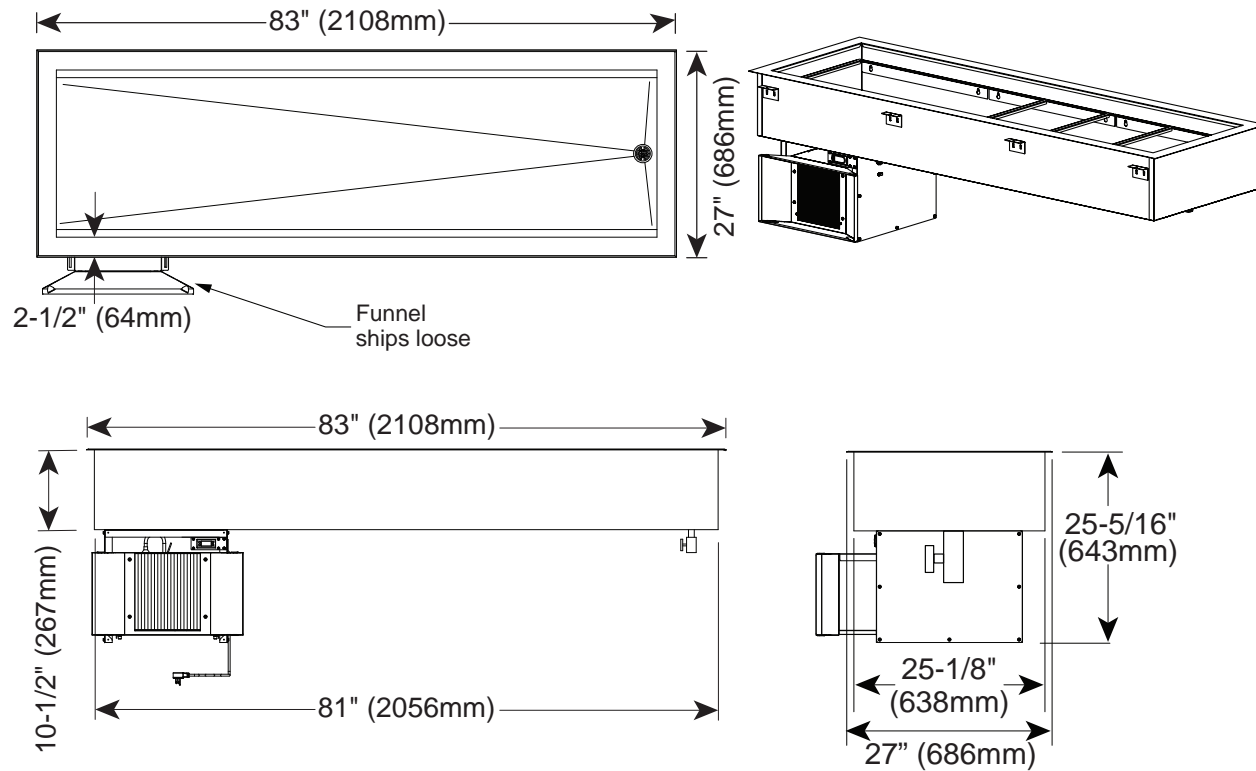

Rough Cut Openings

Model	Countertop Opening	Air Louver Opening
100-CW (one pan)	16-7/8" L x 25-1/2" W (429mm x 648mm)	21" H x 16" W (533mm x 406mm)
200-CW (two pan)	29-7/8" L x 25-1/2" W (759mm x 648mm)	21" H x 16" W (533mm x 406mm)
300-CW (three pan)	42-3/4" L x 25-1/2" W (1085mm x 648mm)	21" H x 16" W (533mm x 406mm)
400-CW (four pan)	55-5/8" L x 25-1/2" W (572mm x 648mm)	21" H x 16" W (533mm x 406mm)
500-CW (five pan)	68-1/2" L x 25-1/2" W (1740mm x 648mm)	21" H x 16" W (533mm x 406mm)
600-CW (six pan)	81-1/2" L x 25-1/2" W (2070mm x 648mm)	21" H x 16" W (533mm x 406mm)

Product/Pan capacity (based on 6" [176mm] deep pans)

	100-CW	200-CW	300-CW	400-CW	500-CW	600-CW
Maximum Capacity	36 lb (16.3 kg)	72 lb (32.6 kg)	108 lb (48.9 kg)	144 lb (65.2 kg)	180 lb (81.5 kg)	216 lb (97.8 kg)
Maximum Volume	22 qt (21 L)	44 qt (42 L)	66 qt (62 L)	88 qt (84 L)	110 qt (105 L)	132 qt (126 L)
Full-Size Pans* - 12" x 20" x 6" GN 1/1 (325mm x 530mm x 176mm)	1	2	3	4	5	6
Half-Size Pans* - 12" x 10" x 6" GN 1/2 (325mm x 265mm x 176mm)	2	4	6	8	10	12
Third-Size Pans* - 12" x 6" x 6" GN 1/3 (325mm x 176mm x 176mm)	3	6	9	12	15	18

*Will accept 2-1/2" (65mm) deep pans and 4" (102mm) deep pans

Placement Details

CUT-OUT DIAGRAM: 100-CW

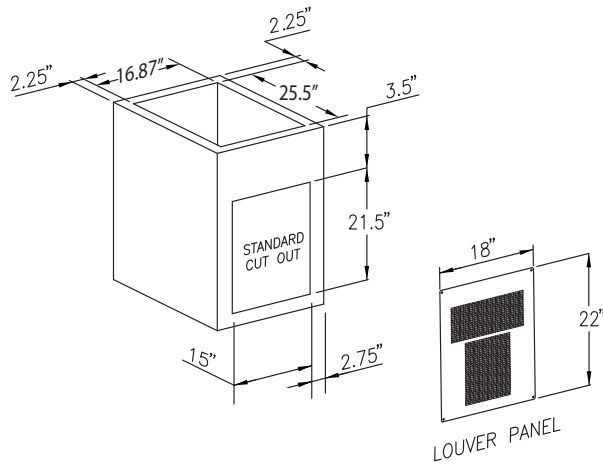

CUT-OUT DIAGRAM: 200-CW to 600-CW

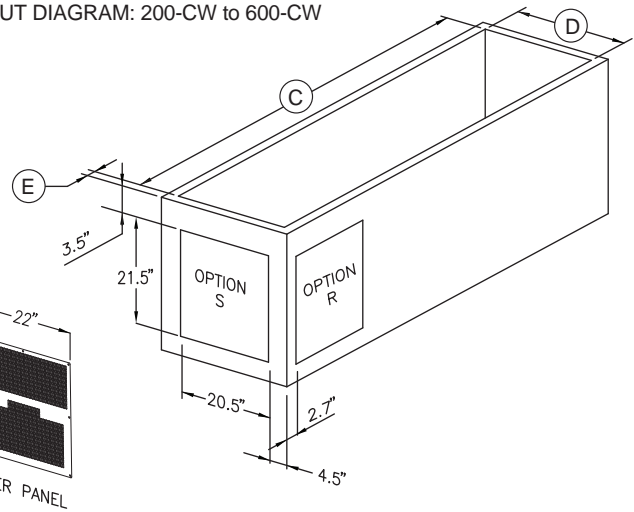

CABINET INTERNAL DIMENSIONS

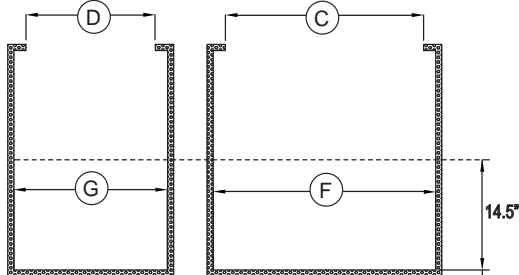

COMPRESSOR AIR FLOW: 100-CW

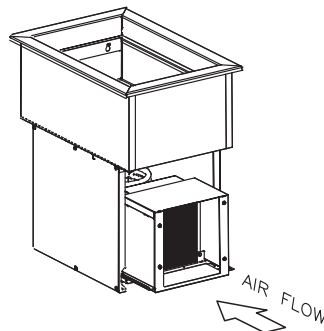

CUT-OUT DIMENSIONS

MODELS	"A"	"B"	"C"	"D"	"E"	"F"	"G"
100-CW	18.5"	27"	16.87"	25.5"		19"	27.5"
200-CW	31.44"	27"	29.87"	25.5"	2.5 - 3.46"	31.95"	27.5"
300-CW	44.25"	27"	42.75"	25.5"	2.5 - 3.46"	44.87"	27.5"
400-CW	57.25"	27"	55.62"	25.5"	2.5 - 3.46"	57.78"	27.5"
500-CW	70.13"	27"	68.5"	25.5"	2.5 - 3.46"	70.69"	27.5"
600-CW	83"	27"	81.5"	25.5"	2.5 - 3.46"	83.6"	27.5"

WARNING: Risk of fire or explosion.
Flammable refrigerant used.
NO electrical components (GFCD)
or electrical connections in this zone.

Exhaust

Total Exhaust Area = 88.7 in²
Exhaust Area slots : 10 x 54 = 540 slots
Perforation size : 0.75 in x .22 in (19 mm x 5.5 mm)

Air Intake

Total Air Intake Area = 88.7 in²
Air Intake Area : 10 x 50 & 2 x 20 = 540 slots
Perforation Size : 0.75 in x .22 in (19 mm x 5.6 mm)

COMPRESSOR ROTATION AND AIR FLOW: 200-CW to 600-CW

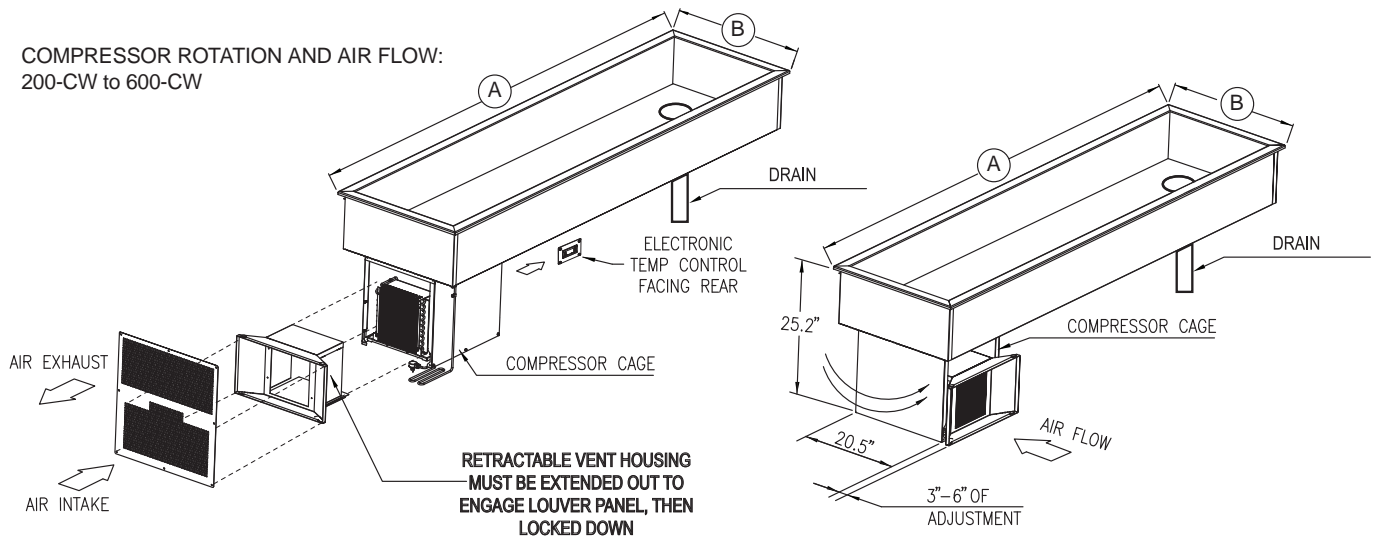

! WARNING

Improper installation, alteration, adjustment, service, cleaning, or maintenance could result in property damage, severe injury, or death.

Read and understand the installation, operating and maintenance instructions thoroughly before installing, servicing, or operating this equipment.

! CAUTION

Appliance and accessories may be heavy. To prevent serious injury, always use a sufficient number of trained and experienced workers when moving or leveling appliance and handling accessories.

Site Installation

The Alto-Shaam Cold Well must be installed in a location that will permit it to function for its intended purpose and to allow adequate clearance for ventilation, proper cleaning, and maintenance access.

Installation Requirements

The countertop material must be water resistant.

A distance of 3/4" (19mm) or more is required between the top rims of the wells to ensure easy cleaning.

The cold well must be installed level.

The cold well must not be installed in any area where the cold well may be directly affected by steam, grease, dripping water, high temperatures, or any other severely adverse conditions.

The cold well must not be installed under a hood.

Avoid installing the cold well under a 4-way ceiling diffuser.

Outdoor use is not recommended.

A water drain or a water catch basin is required for the cold well.

LED lighting is recommended for overhead lighting.

Clearance Requirements

4" (102mm) in front of dual air movement louver.

Weights and Crate Dimensions

Contact Alto-Shaam at 800-558-8744 for current unit weight, shipping weight, and crate dimensions.

NOTICE: To prevent property damage:

Check the dimensions of the doorways and aisles before attempting to move the appliance and pallet to the installation site.

Adjustments are required with initial installation and start-up. It is important that these adjustments be completed by a qualified service technician. Installation and start-up adjustments are the responsibility of the dealer or user. These adjustments include but are not limited to leveling, electrical hook-up and fresh air intake.

1. The cold well must be installed on a stable and level surface - free of vibration and suitably strong enough to support the combined weights of the appliance plus the maximum product load weight.
2. **Do not** install this appliance in any area where it may be affected by any adverse conditions. Avoid placing the appliance in direct sunlight, near heat generating equipment such as ovens, ranges, heaters, fryers, steam kettles, dripping water, high temperatures, or any other severely adverse conditions. Avoid locating the appliance in an unheated room or where the room temperature may drop below 55°F (13°C) or above 86°F (30°C).
3. Lower the cold well into the counter and secure the drop-in cold well to the counter using the supplied brackets.
 - a. Locate square openings on the exterior body of the appliance. Insert securing bracket. Tighten the screw to anchor the appliance tightly to cabinet top.
 - b. Apply a bead of food-grade silicone sealant along the bottom of the cold well decor flange to seal the flange of the cold well to the counter top.
4. The air cooled self contained cold well requires a sufficient amount of cool clean air. The mechanical housing (except on 100-CW appliances) can be rotated 90 degrees to align the condenser air intake with the cabinet fresh air opening. *(see illustration)*
 - a. Loosen the wing nuts located under the cold pan body and rotate the carriage to the desired location.
 - b. Tighten the wing nuts.
 - c. Loosen the adjustment bolts on each side of the retractable condenser shroud and extend the shroud to align with the fresh air louver panel.
 - d. Tighten the adjustment bolts.
 - e. Install the fresh air louver panel.

Cross ventilation inside the cabinet is recommended to maintain an ambient temperature of 86°F (30°C) or less.

Leveling

The cold well should be leveled before the electrical supply is connected. Level the appliance from side-to-side and front-to-back with the use of a spirit level.

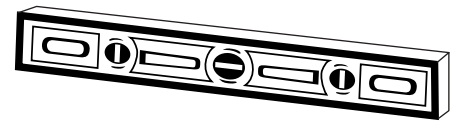

NOTE: *It is important to apply a bead of food-grade silicone sealant along the bottom of the cold well decor flange to seal the flange of the cold well to the counter top.*

Illustration

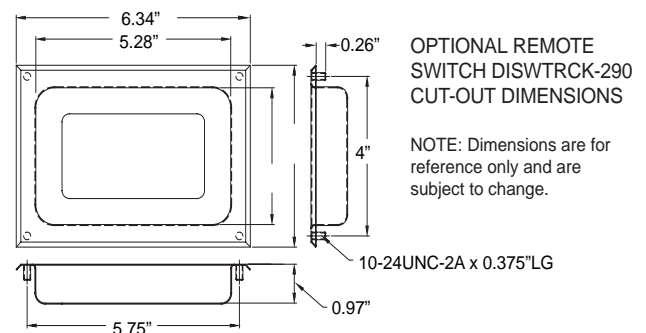
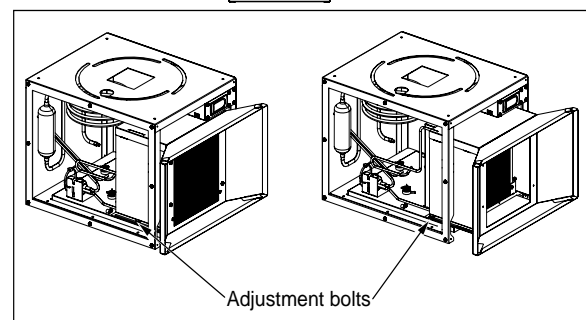
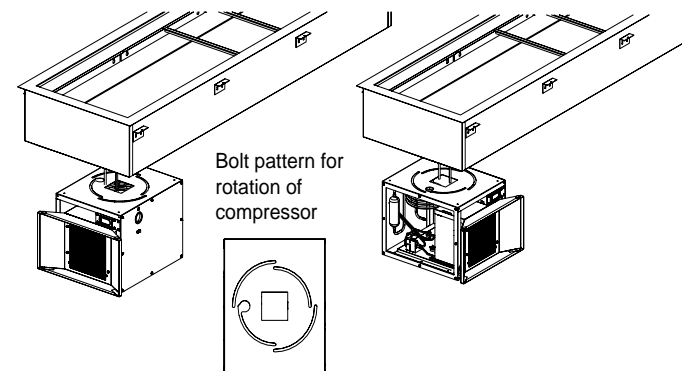

⚠ WARNING

 To prevent serious injury, death, or property damage:

All electrical connections must be made by a qualified and trained service technician in accordance with applicable electrical codes.

 This appliance must be adequately grounded in accordance with local electrical codes or, in the absence of local codes, with the current edition of the National Electrical Code ANSI/NFPA No. 70. In Canada, all electrical connections are to be made in accordance with CSA C22.1, Canadian Electrical Code Part 1 or local codes.

 CE-approved appliances include an equipotential-bonding terminal marked with the symbol shown on the left. Provisions for earthing are to be made in accordance with IEC:2010 60335-1 section 27 or local codes.

⚠ WARNING

Electrical Grounding Instructions:

 This appliance may be equipped with a three-pronged (grounding) plug for your protection against shock hazard and should be plugged directly into a properly grounded three-prong receptacle.

Do not cut or remove the grounding prong from this plug. Removing the grounding prong may result in serious injury, death or property damage.

⚠ WARNING

 Electric shock hazard.

Perform lockout/tagout procedures before cleaning or servicing this appliance.

⚠ CAUTION

 Power source must match voltage identified on appliance rating tag. The rating tag provides essential technical information required for any appliance installation, maintenance or repairs. Do not remove, damage or modify the rating tag.

Electrical						
V	Ph	Hz	A	kW	Plug	
115	1	60	5.0	.6		NEMA 5-15P 15A-125V plug 9' (229mm) long cord

An identification tag is permanently mounted on the front control panel of the appliance.

Permanent wiring or electrical outlets for this appliance must be installed by a licensed electrician in accordance with local, country, or national codes.

NOTE: *The appliance should have its own dedicated line. Condensing appliances are designed to operate with a voltage fluctuation of plus or minus 10% of the voltage indicated on the appliance data tag. Burn out of a condensing appliance due to exceeding voltage limits will void the warranty.*

Position the appliance to allow easy access to the power supply cord in the event of an emergency.

Plug the appliance into a properly grounded receptacle **only**. Arcing will occur when connecting or disconnecting the unit unless all controls are in the **off** position.

It is important that a voltage reading be made at the compressor motor electrical connections while the appliance is in operation to verify that the correct voltage required by the appliance is being supplied. Low or high voltage can detrimentally affect operation and void the warranty.

Plumbing Connection

The drain in the bottom of the cold well is intended to funnel melting frost when the appliance is off or any waste water used to clean the appliance.

Melting frost is equal to a pint of water per day. Water used to clean the appliance varies.

Plumbing connections must be performed by a qualified plumber in compliance with all Federal, State, and Local Codes and Ordinances.



WARNING

To prevent serious injury and property damage from slippery floor conditions, ensure that the drain is connected properly and not blocked.

Prior to start-up
Locate nameplate and record the serial number. The serial number is required when ordering replacement parts or requesting warranty service.
Follow the cut out dimensions provided for specific models to properly size the opening.
The condenser coil must face a ventilated opening in the cabinet.
Inspect the condition of the plug and cord and replace if damaged.
Ensure that all refrigeration lines are not obstructed before, during, and after installation in the counter.
Check all sheet metal surrounding the mechanical compartment to ensure that damage has not occurred in these areas.
The cold well should have a dedicated electrical supply line.
Plumbing connections have been performed by a qualified plumber in compliance with all Federal, State, and Local Codes and Ordinances.
Plug in unit and press the On/Off power switch to the on (I) position.
Allow the appliance to cool down to temperature. A layer of frost will form and remain around the inside perimeter of the rail.
Confirm that the appliance is holding temperature. Set the control to the desired temperature.

NOTE: *Failure to follow installation guidelines and recommendations may void the warranty on the appliance.*



Controller Operation





POWER ON / OFF: Press and hold the Power Button  for more than 3 seconds or until LED display turns On/Off.

MANUAL DEFROST: Press and hold the Defrost Button  for more than 3 seconds (melting snowflake will light).

CHANGE SET POINT: To raise temperature

1. Press and hold  button for 1 second to access set point.
2. When set point starts flashing, press up button  to adjust set point.
3. Press  button for 3-seconds to save set point.





CHANGE SET POINT: To lower temperature

1. Press and hold  button for 1 second to access set point.
2. When set point starts flashing, press down button  to adjust set point.
3. Press  button for 3-seconds to save set point.

CAREL CONTROLLER CODES

DISPLAYED ALARM CODE	ALARM
E0	Control probe
E1	Defrost probe
dOr	Open door
LO	Low temperature
HI	High temperature
CHt	Dirty condenser

CAREL CONTROLLER OPERATION

LED	FUNCTION
	Compressor energized
	Defrost in progress
	Evaporator fan energized
	An alarm is occurring

Operating the Cold Well

General Operating Notes

All required pan divider bars must be used at all times with the pan configuration chosen. Before loading food into the appliance, use a pocket-type thermometer to ensure that all products are within the cold safe zone with an internal temperature of 36°F to 40°F (2°C to 4°C).

Check food temperatures.

After all products are loaded into the appliance, periodically use a pocket thermometer to check each food item to ensure that correct temperatures are being maintained.

Serve fresh, cold food.

Keep cold foods looking fresh. Occasionally stir or rotate food as needed. Wipe spills immediately.

Do not add water to the cold well.

Alto-Shaam cold wells do not require the addition of water. Adding water is not recommended since water will accelerate the deterioration of the product, damage the appliance, and void the warranty.

Ambient Conditions

The cold well is designed for normal operating temperatures are between 70° F (21°C) and 86°F (32°C). Operating outside of those temperatures may cause premature product wear or failure. The temperature control has been factory-preset for the unit to operate at the optimum temperature. However, varying ambient conditions including elevation, food type, and method of operation may require control adjustments to reach the desired temperature.

It is normal for the cold well to develop an even layer of frost during operation. **NOTE:** Keeping the hinged cover closed as much as possible will prevent excessive frost buildup.

NOTE: If the cold pan temperature remains too warm and the temperature control is at the minimum setting, contact an Alto-Shaam service technician.

Morning Start-Up

1. Place pan dividers and empty pans in the wells. Cold pan cleaning may be performed at this time.
2. There are two available methods of turning on power to the unit. Either press the ON/OFF switch at the base near the compressor, or use the controller power on/off button.
3. Allow 50–60 minutes for the cold pan to chill before loading product.
4. Load the product and proceed with food preparation. **NOTE:** Product entering the cold pan must be at 37°F +/- 2°F or less. All pans should be in position.

Evening Shutdown

1. Remove leftover product from the cold pan at the end of the day's preparation. Discard leftover product or store in a commercial refrigerator.
2. Turn off power to unit by pressing the ON/OFF switch at the base near the compressor, or use the controller power on/off button. This will allow unit to thaw which allows for better operation when starting up unit for next day operation.
3. Unit cleaning may be performed at this time once the frost has melted off the surface.

NOTE: Use a clean, dry cloth to remove any remaining pooled water from the bottom of the pan.

Cleanliness, operating efficiency, and equipment appearance contribute to savory, appetizing foods.

Comprehensive cleanliness is essential for maintaining natural food flavor.

- Control of visible soil (dirt) and invisible soil (germs) is necessary.
- A thorough sanitation approach ensures equipment cleanliness, efficiency, and utility.
- A good sanitation program helps prevent food-borne illnesses.

Sanitation Program Focus

- Train staff in basic sanitation procedures: personal hygiene, proper handling of raw foods, cooking to safe internal temperatures, and routine monitoring of food temperatures.
- Maintain a controlled holding environment for prepared foods.
- Monitor and control temperatures during receiving, storage, preparation, and service.

Temperature Monitoring

- Measure safe temperatures of hot and cold foods using internal product temperature.
- Use thermometers routinely on all products requiring specific holding temperatures.

Internal Food Product Temperatures		
Hot Foods		
Danger Zone	40°F to 140°F	4°C to 60°C
Critical Zone	70°F to 120°F	21°C to 49°C
Safe Zone	140°F to 165°F	60°C to 74°C
Cold Foods		
Danger Zone	Above 40°F	Above 4°C
Safe Zone	36°F to 40°F	2°C to 4°C
Frozen Foods		
Danger Zone	Above 32°F	Above 0°C
Critical Zone	0°F to 32°F	-18°C to 0°C
Safe Zone	0°F or Below	-18°C or Below

Internal food temperatures are provided as a courtesy. Always contact the FDA at the number below for any food safety-related questions and best practices.

Center for Food Safety and Applied Nutrition
 Food and Drug Administration
 Phone: 1-888-SAFEFOOD
www.foodsafety.gov

Protecting Stainless Steel Surfaces

It is important to guard against corrosion in the care of stainless steel surfaces. Harsh, corrosive, or inappropriate chemicals can completely destroy the protective surface layer of stainless steel. Abrasive pads, steel wool, or metal implements will abrade surfaces causing damage to this protective coating and will eventually result in areas of corrosion. Even water, particularly hard water that contains high to moderate concentrations of chloride, will cause oxidation and pitting that result in rust and corrosion. In addition, many acidic foods spilled and left to remain on metal surfaces are contributing factors that will corrode surfaces.



Proper cleaning agents, materials, and methods are vital to maintaining the appearance and life of this appliance. Spilled foods should be removed and the area wiped as soon as possible but at the very least, a minimum of once per day. Always thoroughly rinse surfaces after using a cleaning agent and wipe standing water as quickly as possible after rinsing.

Cleaning Agents

Use non-abrasive cleaning products designed for use on stainless steel surfaces. Cleaning agents must be chloride-free compounds and must not contain quaternary salts. Never use hydrochloric acid (muriatic acid) on stainless steel surfaces. Failure to observe this precaution will void the warranty. Always use the proper cleaning agent at the manufacturer's recommended strength. Contact your local cleaning supplier for product recommendations.

Cleaning Materials

Cleaning can usually be accomplished with the proper cleaning agent and a soft, clean cloth. When more aggressive methods are needed, use a non-abrasive scouring pad on difficult areas and make certain to scrub with the visible grain of surface metal to avoid surface scratches. Never use wire brushes, metal scouring pads, or scrapers to remove food residue. Failure to observe this precaution will void the warranty.

NOTICE	
 No scrapers	To protect stainless steel surfaces, completely avoid the use of abrasive cleaning compounds, chloride based cleaners, or cleaners containing quaternary salts. Never use hydrochloric acid (muriatic acid) on stainless steel. Never use wire brushes, metal scouring pads or scrapers.
 No wire brushes	
 No steel pads	

! WARNING	
	To prevent serious personal injury, death, or property damage: The appliance must be cleaned thoroughly to avoid deposits of grease and or food residue inside the appliance that may catch fire. If fat deposits and/or food waste inside the appliance ignite, shut down the appliance immediately and keep the appliance door closed to extinguish the fire. If further extinguishing is required, disconnect the appliance from the main power and use a fire extinguisher (do not use water to extinguish a grease fire!). Failure to clean the appliance properly invalidates the warranty and relieves Alto-Shaam of all liability.

Clean the appliance daily

1. Press the On/Off switch to the **off** (O) position.
Disconnect the appliance from the power source. Allow the frost on the rail of the appliance to melt.
2. Remove, cover or wrap, and store food product under refrigeration.
3. Remove and wash any detachable items such as pans and divider bars with hot, soapy water. Dry with a clean, damp lint-free cloth.
4. Drain water from the appliance.
5. Remove any food scraps.



NOTICE: Never use of abrasive cleaning compounds, chloride based cleaners, or cleaners containing quaternary salts.

Never use hydrochloric acid (muriatic acid) on stainless steel.

6. Clean the interior and exterior of the appliance with a mild soap and water solution. Apply the solution with a clean, damp cloth. Do not use commercial or household cleaners that contain ammonia. Wipe with a clean, damp cloth to remove all detergent residue. Dry with a clean, lint-free cloth.
7. Wipe the interior surfaces with a sanitizing solution. This solution must be approved for use on food contact surfaces.
8. Clean the control panel, thermostat knob, and air intake louvers.

Always follow appropriate state or local health (hygiene) regulations regarding all applicable cleaning and sanitation requirements for foodservice equipment.

⚠ WARNING

To prevent serious personal injury, death, or property damage:

Do not steam clean, hose down or flood the interior or exterior with water or liquid solution of any kind. **Do not** use water jet to clean. Failure to observe this precaution will void the warranty.

⚠ WARNING

Electric shock hazard.

Perform lockout/tagout procedures before cleaning or servicing this appliance.

Preventative Maintenance Program

(perform monthly)

1. Clean all condenser coils.

Condenser coils are a critical components in the life of the compressor and must remain clean to ensure proper air flow and heat transfer.

Clean the condenser coils with a coil cleaner and/or a vacuum, cleaner, and a brush. Brush the coil in the direction of the fins.

2. Clean the fan blade on the condensing unit.

The fan blade collects dust and transfers the dust into the condenser coils. Clean the fan blade with a vacuum, cleaner, and a brush.

3. Inspect the condition of the plug and cord and replace if damaged.
4. Check the condition of the control panel overlay. Are there any tears or excessive wear on the graphic? Replace if necessary.

NOTICE: Do not use sharp utensils.

Use of any filter over the condenser coil may result in poor performance of the appliance.

The factory does not recommend the use of any auxiliary filter. Any failures of the appliance as a result of an auxiliary filter will not be covered under warranty.

Problem	Possible Cause(s)	Remedy
The appliance will not cool.	The thermostat is off.	Press the On/Off switch to the on (I) position.
	The appliance is unplugged.	Plug in the appliance.
	The circuit breaker is tripped.	Replace the circuit breaker.
	The problem is unknown.	Call the Alto-Shaam service agency.
The appliance does not operate.	There is no power to the appliance.	Plug in the appliance and check the power switch.
	The temperature control is off.	Check the temperature control.
	The temperature control is faulty.	Test the temperature control.
	The compressor is overheated.	Clean the condenser coil.
	The condenser fan is faulty.	Service the condenser fan.
	The overload protector is faulty.	Test the overload.
	The compressor relay is faulty.	Test the compressor relay.
	The compressor is faulty.	Call the Alto-Shaam service agency.
The appliance short cycles.	The condenser coil is dirty.	Clean the condenser coil.
	The condenser fan is faulty.	Service the condenser fan and motor.
	The compressor is faulty.	Call the Alto-Shaam service agency.
	The overload is repeatedly tripping.	Check the outlet voltage.
The appliance condenser runs continuously.	The condenser coil is dirty.	Clean the condenser coil.
	The condenser fan is faulty.	Service condenser motor
	The appliance is low on refrigerant.	Call service agency
The appliance is too cold.	The temperature control is set too low.	Adjust the temperature control to a higher setting.
	The temperature control is faulty.	Test the temperature control.
The appliance is noisy.	The compressor mountings are loose or hardened.	Tighten or replace the compressor mountings.
	The condenser fan is damaged or hitting the fan shroud.	Inspect the condenser fan for interference or damage.

Introduction Alto-Shaam, Inc. warrants to the original purchaser only, that any original part found to be defective in material or workmanship will be replaced with a new or rebuilt part at Alto-Shaam's option, subject to provisions hereinafter stated.

Warranty Period The original parts warranty period is as follows:

- For all other original parts, one (1) year from the date of installation of appliance or fifteen (15) months from the shipping date, whichever occurs first.
- The labor warranty period is one (1) year from the date of installation or fifteen (15) months from the shipping date, whichever occurs first.
- Alto-Shaam will bear normal labor charges performed during standard business hours, excluding overtime, holiday rates or any additional fees.
- For the refrigeration compressor, if installed, the warranty period is five (5) years from the date of original installation of the appliance.
- For heating elements on Halo Heat® Cook and Hold ovens, the warranty period is for as long as the original owner owns the oven. This warranty period applies to units sold after 2/1/2009 and excludes holding-only ovens.
- To be valid, a warranty claim must be asserted during the applicable warranty period. This warranty is not transferable.

Exclusions This warranty does not apply to:

- Calibration.
- Replacement of light bulbs, rubber gaskets, grease filters, air filters, racks, jet plates, and/ or the replacement of glass due to damage of any kind.
- Equipment damage caused by accident, shipping, improper installation or alteration.
- Equipment used under conditions of abuse, misuse, carelessness or abnormal conditions, including but not limited to, equipment subjected to harsh or inappropriate chemicals, including but not limited to, compounds containing chloride or quaternary salts, poor water quality, or equipment with missing or altered serial numbers.
- Equipment damage caused by use of any cleaning agents other than those recommended by Alto-Shaam, including but not limited to damage due to chlorine or other harmful chemicals.
- Any losses or damage resulting from malfunction, including loss of food product, revenue, or consequential or incidental damages of any kind.
- Equipment modified in any manner from original model, substitution of parts other than factory authorized parts, unauthorized removal of any parts including legs, or unauthorized addition of any parts.
- Equipment damage incurred as a direct result of poor water quality*, inadequate maintenance of steam generators and/or surfaces affected by water. Water quality and required maintenance of steam generating equipment is the responsibility of the owner/ operator.
- Equipment damage incurred as a result of not following the required maintenance schedule published in the manuals for the equipment.

Conclusion This warranty is exclusive and is in lieu of all other warranties, express or implied, including the implied warranties of merchantability and fitness for a particular purpose. No person except an officer of Alto-Shaam, Inc. is authorized to modify this warranty or to incur on behalf of Alto-Shaam any other obligation or liability in connection with Alto-Shaam equipment.

**Refer to the product spec sheet for water quality standards.*



ALTO-SHAAM.

Menomonee Falls, WI U.S.A.

Phone 800-558-8744 | +1-262-251-3800 | alto-shaam.com

ASIA

Shanghai, China
Phone +86-21-6173-0336

AUSTRALIA

Brisbane, Queensland
Phone 800-558-8744

CANADA

Concord, Ontario Canada
Toll Free Phone 866-577-4484
Phone +1-905-660-6781

FRANCE

Aix en Provence, France
Phone +33(0)4-88-78-21-73

GMBH

Bochum, Germany
Phone +49 [0]234 298798-0

ITALY

Padua, Italy
Phone +39 3319273313

INDIA

Pune, India
Phone +91 9657516999

MEXICO

Phone 262-251-3800 Ext. 6506

MIDDLE EAST & AFRICA

Dubai, UAE
Phone +971-4-321-9712

CENTRAL & SOUTH AMERICA

Miami, FL USA
Phone 262-251-3800 Ext. 6506