

ALTO SHAAM®

OPERATION and CARE MANUAL



HOT/COLD FOOD DELIVERY SYSTEMS

1400-DC/20

1400-DC/24

HALO
HEAT

COOK/HOLD/SERVE SYSTEMS



W164 N9221 Water Street • P.O. Box 450 • Menomonee Falls, Wisconsin 53052-0450 U.S.A.
PHONE: 262.251.3800 FAX: 262.251.7067 • 800.329.8744 U.S.A./CANADA WEBSITE:
800.558.8744 U.S.A./CANADA 262.251.1907 INTERNATIONAL DIVISION www.alto-shaam.com



HOT/COLD FOOD DELIVERY SYSTEM

SYSTEM DESCRIPTION

Food quality and service are more important than ever in today's institutional food service market. Alto-Shaam recognizes this fact and developed the Delivery Cart using the highest quality stainless steel, insulating material, and the finest workmanship.

The Alto-Shaam Delivery Cart is a self-contained, complete hot/cold meal preparation and delivery system. This system is simple in concept and is designed for any completely new delivery method or for adaptation into any existing institutional food service method of preparation.

The heat source for the hot compartments consist of a resistance wire element. This thermal cable element is wrapped in exact configurations against the walls of the heated compartments providing an evenly applied, highly controlled, heat input.

The design and operational characteristics of the ovens eliminate the need for a heat circulating fan, thereby eliminating the additional moisture loss associated with that type of heat induction. Because of the even heat application, the quality of hot food is maintained for longer periods of time. The actual time depends on the type and quantity of product.

The refrigeration section of the Delivery Cart utilizes a highly reliable commercial refrigeration unit. The cold compartment is fully insulated from the heated sections.

Through the best arrangement of the controls, operation of this appliance is simplified. One power switch automatically energizes all functions. A variable timer for each heated section automatically switches the oven mode from holding to a fixed reheating or cooking temperature. With the timer in the OFF position, the oven is at a reduced, fixed holding temperature.

EXTENDED STORAGE & BATTERY CHARGING

The Model 1400-DC with drive delivery cart contains rechargeable batteries that were fully charged prior to shipment. **Failure to properly store the unit and charge the batteries will cause battery failure, and the battery warranty will become null and void.**

Be sure to store delivery cart in a cool and dry location. If the cart will not be activated for service within 30 days of receipt, the batteries must be charged by connecting the cord to electrical power for storage duration.

When removed from active service, the unit can remain continuously connected to power to maintain full battery charge. Be sure to turn the Drive System Power Switch OFF when not in use.

RECEIVING & UNPACKING

The Alto-Shaam Delivery Cart has been thoroughly tested, checked for proper calibration, and inspected to ensure only the highest quality equipment is provided.

Upon receipt of the Delivery Cart, check the exterior of the shipping crate for any physical damage that could result in concealed damage to the contents. Uncrate the unit carefully and inspect for any shipping damage. Immediately report any damage to the delivering freight carrier. (See the *Transportation Damage and Claims* section located in this manual.)

If the Delivery Cart was not received from the carrier in an upright position but appears to be undamaged, carefully restore the unit to the correct position as soon as possible. The cart must remain in an upright position for a minimum of **24 hours before use**, to allow the compressor oil to drain back into the crankcase.

Remove the uncrated unit from the skid with a lift-truck or roll it off the skid by means of the temporary ramp provided in the crate.



If a lift-truck is used to remove the Delivery Cart from the skid, caution should be used to avoid damage to the drive motor assembly located beneath the unit.

Save all the information and instructions packed inside the cart. Complete and return the warranty card to the factory as soon as possible to ensure prompt service in the event of a warranty parts or labor claim.

MODEL 1400-DC



HEATED COMPARTMENTS

SPILL PAN 2 ea.

SIDE RACK

— 1" (25mm) Standoff 4 ea.

COLD COMPARTMENT

Condensate Pan 1 ea.

SIDE RACK

— 1" (25mm) Standoff 2 ea.

SIDE RACK

— 3" (76mm) Standoff 1 ea.

TRAYS, HALF-SIZE

Model 1400-DC/20 40 ea.

Model 1400-DC/24 48 ea.

Check to ensure that all the above items have been received as standard with each Delivery Cart.

IMPORTANT SAFEGUARDS

- Read this manual carefully before operating the Delivery Cart.
- Observe all safety precautions noted in this manual.
- The Delivery Cart should be used for food preparation only.
- Use caution to protect against the risk of electric shock when operating in the presence of water or other liquids.
- Always move the unit to the workplace BEFORE connecting the power cord.
- This unit should not be operated in an enclosed area, exposed to excessive heat, steam, water, or other adverse conditions.
- For best service, the unit should be level.
- Do not use cart if controls are not functioning properly. Refer to Trouble Shooting Guide in this manual or contact an authorized service technician.

HOT/COLD FOOD DELIVERY SYSTEM

ELECTRICAL INSTALLATION

The power specifications are located on the Delivery Cart identification nameplate. This nameplate is permanently attached to the cart and must be located to determine and verify power requirements.

EXAMPLE

SERIAL NUMBER & WARRANTY CODE
 MAXIMUM RATED WATTAGE
 ALTO-SHAAM IDENTIFICATION MODEL NUMBER

MODEL	1400-DC/XX		
SERIAL NO.	XXXX-XX	WATTS	XXXX
VOLTS	XXX	1 PH	XX HZ
REFRIGERANT		POUNDS	
DESIGN PRESSURE	HI	LO	

ALTO-SHAAM, INC. MILW. WI. PAT. NOS. 252097

MAXIMUM RATED VOLTAGE
 MAXIMUM RATED FREQUENCY

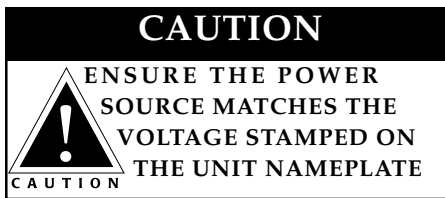

The unit is provided with a 10 ft. (3048mm) electrical cord with plug. For U.S. installation, the attachment plug must be a NON-LOCKING, 30 ampere, 250 volt, 2-pole, 3-wire grounding plug — NEMA 6-30P.

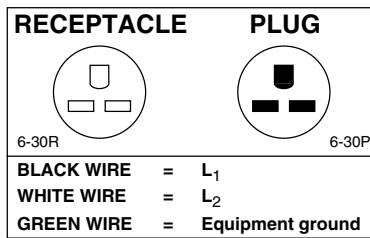

The electrical outlets used for the Delivery Cart must be properly grounded in accordance with the National Electrical Code and applicable local codes.

Before plugging the unit in or disconnecting it from the power source, make certain the unit power switch is in the OFF position. THE UNIT POWER SWITCH IS LOCATED ON THE CONTROL PANEL. The unit circuit breaker should be in the ON [UP] position.

Continue with "Preparation" and follow the guidelines under "General Operation" to assure the cart is functioning properly.

UNIT PREPARATION

GENERAL INFORMATION

For the best service, the unit should be level. The Delivery Cart should not be operated in an enclosed area, exposed to excessive heat, steam, water, or any other adverse conditions.

Clean the Delivery Cart thoroughly before using. Wipe the exterior with a clean damp cloth. Wash the interior, tray racks, and trays with a mild soap solution and rinse well.

The condensate pan is located on the bottom of the refrigerated compartment, just below the side rack with the 3" (76mm) standoff.

The condensate pan size is:
 2-1/8" x 2-3/4" x 19-1/2"
 (54mm x 70mm x 495mm)

NOTE: The condensate pan should be checked for water after each operation and emptied as required.

HEATED COMPARTMENT

The heated compartment door trim is color coded with red, numbered stripes.

HEATED COMPARTMENT
 TRAY SIDE RACK

To install the Tray Side Racks in the oven compartments, locate 4 racks with the 1" (25mm) standoff.

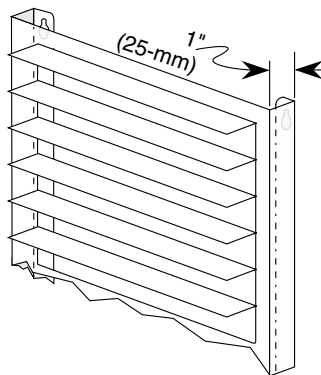

Position the keyhole openings in the Tray Side Racks over the shoulder bolts located on the sides of the interior oven compartments. Push down to lock the Tray Side Racks into position.

Insert an oven Spill Pan directly on the bottom surface of each oven compartment.

COLD COMPARTMENT

The cold compartment door trim is color coded with a blue, numbered stripe. There are two types of Tray Side Racks for the cold compartment — 2 with a 1" (25mm) standoff (same as the heated compartments) and 1 with a 3" (76mm) standoff.

The two side racks with the 1" (25mm) standoff must be installed in the cold compartment toward the outside (door-hinge side) of the compartment. Install the rack keyhole bracket openings over the shoulder bolts. Push down to lock in place.

COLD COMPARTMENT
 TRAY SIDE RACK

To install the tray side rack with the 3" (76mm) standoff in the cold compartment, position the keyhole openings in the Tray Side Racks over the shoulder bolts located on inside (door latch side) of the interior cold compartment. Push down to lock the Tray Side Racks into position.

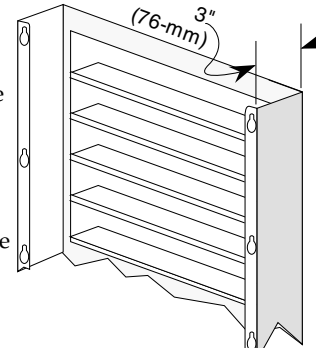

INITIAL BATTERY CHARGE

The battery life expectancy is about two years.

Before putting the delivery cart into service the motor drive batteries must be fully charged. Move the delivery cart to the designated work area and connect the unit to the power source for a minimum of 12 hours prior to use (SEE EXTENDED STORAGE AND BATTERY CHARGING SECTION OF THIS MANUAL.)

When connecting the delivery cart to the power source, allow sufficient clearance for ventilation of the refrigerator air vents located at the lower portion of the cart, on both the control side and the non-control side. The brake on the motor drive as well as non-motorized versions of the cart must be engaged at all times unless it becomes necessary to manually push the cart. (SEE SECTION TITLED MOTOR DRIVE CONTROL FOR MORE INFORMATION.)

HOT/COLD FOOD DELIVERY SYSTEM

CIRCUIT BREAKERS

The circuit breaker for the 1400-DC delivery cart is accessible through the tray storage area located on the bottom surface of the control compartment. For cart operation the circuit breaker switch must be in the ON position.

TEMPERATURE DISPLAY

Sensors controlling the temperature of each compartment are preset at the factory. When the preset temperatures are reached, each digital temperature display will fluctuate within several degrees of the preset temperature. This is a normal operating condition of the electronic control and has no adverse effect on the temperature within the holding compartment.

CONTROL PANEL

Each food delivery cart features an electronic control panel to activate or control the compartment temperatures. The control can be factory ordered to indicate interior compartment temperatures in degrees Fahrenheit or degrees Celsius. The control offers the operator the flexibility of independent compartment operation or the ability to operate both hot and cold compartments at the same time. Always preheat or prechill all compartments prior to using the cart.

TEMPERATURE CONTROLS

COLD COMPARTMENTS

The digital display will illuminate and show the actual air temperature of the refrigerator (cooler). Models with a freezer will show the actual air temperature inside the freezer compartment.

⇒ REFRIGERATOR 38°F (3°C)

Refrigeration is preset at 38°F (3°C). Following a prechill period of approximately one hour, the refrigeration compartment will have reached the preset temperature.

⇒ AUTOMATIC DEFROST

The defrost function is a standard control operation which automatically initiates at the end of six (6) hours of continuous operation in either the *cold* mode or in the *hot and cold* mode. At the start of the defrost cycle "dFr" appears in the cooler display. Defrost is preset at the factory and timed for an approximate 35 minute cycle. During this time period, all compressor function ceases operation in order to fully defrost the evaporator coil. At the completion of the defrost cycle, the compressor will resume normal operation and quickly return the cold compartment to the proper preset temperature. The short time period for defrosting has no significant effect on the internal temperature of the refrigerated product.

HEATED COMPARTMENTS

Both cooking and holding temperatures are preset at the factory. When the control for the heated compartments is activated, the two digital displays will illuminate and indicate the actual air temperature inside each heated compartment. In order to reach the preset cooking temperature, the timer for each heated compartment must be activated. The preset cooking temperature will be maintained until the timer elapses to zero (OFF). When the timer for each heated compartment elapses to zero, the heated compartments will automatically decrease to the preset holding temperature. To maintain the preset holding temperature in each heated compartment, do not activate the timers.

⇒ HOLDING 190°F (88°C)

The heated compartments are preset at 190°F (88°C). Following a preheating period of approximately one hour, the heated cavities will have reached the preset temperature for holding hot foods.

⇒ COOKING 285°F (141°C)

When the cooking timers are set, the heated compartments will automatically maintain the preset cooking (rethermalization/regeneration) temperature. Cooking time is displayed in minutes and can be increased ▲, decreased ▼, or deactivated by pressing **OFF**. The temperature displays will indicate the actual air temperature within the heated compartments.

PLEASE NOTE: As an option, an alternate cooking/holding temperature may have been preset by the factory when the order was placed: cooking 265°F (129°C); holding 180°F (82°C), 170°F (76°C), or 160°F (70°C).

CAUTION

To prevent the unit from being accidentally deactivated during the cooking mode the cooking timers must be manually deactivated or must be allowed to cycle to zero before pressing the power switch **OFF**. Pressing the power switch **OFF** prior to deactivating the timers will **NOT** result in any change to the control status.

1400-DC CONTROL PANEL

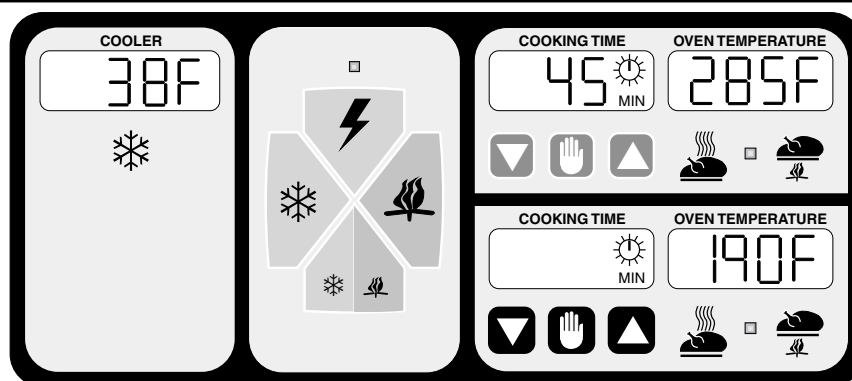

**STANDARD
DELIVERY
CARTS**

SPECIAL ORDER DELIVERY CARTS

▼ COOKING TEMPERATURE: 265°F (129°C) ▼ HOLDING TEMPERATURE: 180°F ; 170°F ; or 160°F (82°C) (76°C) (70°C)

OPERATION

START-UP

Delivery carts are equipped with a motorized drive. Refer to the motor drive control instructions before moving the cart.

1. Connect the power cord into an appropriate outlet.
2. Close the heated compartment vents located on the inside of each compartment door.
3. Select mode of operation:
 - Press ❄️ for Refrigeration & Freezer compartments (BLUE).
 - Press 🔥 for Heated compartments (RED).
 - Press ❄️🔥 for both Cold & Heated compartments (BLUE/RED).
4. Preheat and prechill empty compartments (without trays) for approximately one hour. To preheat to the cooking (REETHERMALIZE-REGENERATE) temperature, set the timers for a minimum of one hour. Following a preheating time period of approximately one hour, the refrigerated and heated compartments will have reached preset temperatures.

LOAD COMPARTMENTS

5. Load filled trays into appropriate hot and cold compartments. Products requiring maintenance below refrigerated temperatures can be stored in the freezer compartment of freezer equipped models.

REETHERMALIZE or HOLD

6. Reset timers for the appropriate amount of cooking time required to rethermalize (REGENERATE). Activate timers by pressing ▲ to increase or ▼ to decrease set time (IN MINUTES).

**TO REETHERMALIZE CHILLED MEALS
SET COOKING TIME: 60 MINUTES**
**TO REETHERMALIZE FROZEN MEALS
SET COOKING TIME: 105 MINUTES**
1 HOUR, 45 MINUTES

Following rethermalization, the temperature will automatically decrease and maintain the preset holding temperatures until the unit power switch is pressed OFF.

TO STOP OR RESET TIMERS, PRESS 

DELIVERY

7. Use the Motor Drive Control to transport the cart to the designated service area. (SEE MOTOR DRIVE CONTROL OPERATION)
Before moving cart, turn power switch ⚡ OFF. Disconnect power cord from the outlet and place the cord in cord holder or end-brackets provided. Upon reaching the service area, plug the power cord into an appropriate outlet and turn power switch ON. Foods will be automatically maintained at proper serving temperatures throughout the service period.

8. Assemble trays for meal service:

Extend U-shape, serving tray shelves located in the center of unit. Open the doors to both the hot and cold compartments and assemble meals.

FOR 1400-DC: Place serving tray on shelf holder. Transfer hot and cold half trays onto serving tray.

For best service, all meals should be served in a timely manner. Following meal service turn the power switch OFF and return power cord to cord holder.

9. Use the Motor Drive Control to transport cart to designated cleaning area. Clean cart and trays after each meal service. Follow the care and cleaning guidelines located in this manual. After each use, empty the water from the condensate pan located in the lower section of the refrigeration compartment.



Cold food for rethermalization or reheating must never be added to the unit while hot food is being held.

OPERATING CAUTIONS

CAUTION



**USE HAND PROTECTION
WHEN HANDLING
HOT COMPARTMENT
ITEMS.**

Do not use the cart if controls are not functioning properly. Refer to the Trouble Shooting Guide located in this manual or telephone an authorized service technician.

TURN DRIVE SYSTEM POWER SWITCH OFF WHEN NOT IN USE.

Observe all safety precautions noted in this manual.

CAUTION

For proper sanitation, do not put soiled trays back into the cart until all meals are served.



The motor drive brake must be engaged at all times unless it becomes necessary to move the cart manually. After moving the cart manually, the wheels of the cart and the motor drive assembly will respond to even a slight incline unless the brake is reset. Maintaining a "set" break to keep the cart in a stationary position is an important safety factor.

To keep drive batteries fully charged, the cart must remain connected to the power source when not in service for a maximum of 30 days. For inactive periods longer than 30 days. SEE EXTENDED STORAGE SECTION IN THIS MANUAL.

CLEANING and MAINTENANCE



A comprehensive program of sanitation will provide essential cleanliness.

This is important to build quality service as the foundation of patient satisfaction.

Cleanliness, top operating efficiency and appearance of equipment contribute considerably to savory, appetizing food. The safest way to ensure full natural food flavor is through cleanliness. This means good control of both visible soil (dirt) and invisible soil (microorganisms).

Establishing a routine cleaning and maintenance schedule will help keep the hot/cold food delivery cart running at top operating efficiency and is an absolutely essential part of a comprehensive sanitation program.

Good equipment maintained and kept clean works better and lasts longer. Protect your investment.

Always follow appropriate local health (hygiene) regulations regarding all applicable cleaning and sanitation requirements for equipment.

CAUTION

Always disconnect the food delivery cart from the power source before cleaning or servicing.



TIRE MAINTENANCE

Tire pressure requires periodic checking. Add air as required to maintain a pressure level not to exceed 60 pounds per square inch (4 bars).

CLEANING

1. After disconnecting the delivery cart from the power source, wipe the power cord if necessary, and insert it properly in the power cord holder located along the lower perimeter of the cart or the external end-brackets provided.
2. Remove all trays, drip pans and condensate pans. Wash these items in the dishwasher. Rinse well and let dry.
3. Clean all interior compartments after each meal service. Any spilled food should be removed with a damp cloth and any good alkaline or alkaline chlorinated based commercial detergent or grease solvent at the recommended strength. Use a plastic scouring pad or oven cleaner for difficult areas. Avoid the use of abrasive cleaning compounds, chloride based cleaners, or cleaners containing quaternary salts.
NOTE: Never use hydrochloric acid (muriatic acid) on stainless steel. Allow surfaces to air dry for maximum effectiveness.
4. The refrigerator compartment may be washed with a baking soda (sodium bicarbonate) solution. Use 3 tablespoons (50 mil) of baking soda for each quart (liter) of water.
5. To help maintain the protective film coating on polished stainless steel, clean the exterior of the cabinet with a cleaner recommended for stainless steel. Spray on a clean cloth and wipe with the grain of the stainless steel.
6. To ensure proper air circulation, the refrigeration condenser coil grill must be periodically checked and cleaned. Remove the vent housing cover from the control side of the cart. Brush or vacuum the grill approximately once a month or as soon as collection of lint, dust, or dirt is observed at the condenser. This is a very important maintenance procedure which many times is overlooked. Regular care and cleaning of the coils will result in longer service of the refrigeration unit and less energy to operate.
7. All delivery cart door gaskets are removable. To maintain a good door seal and to extend the life of the gaskets, periodically wash the gaskets with warm sudsy water. Always rinse carefully to remove all soap or detergent residue.
8. In the event the delivery cart is out of operation for an extended period of time, thoroughly clean and sanitize the cart and clean the door gaskets prior to use.

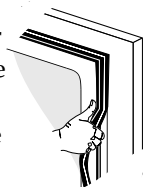

CAUTION



Do not steam clean the exterior or interior of the unit. Use caution to prevent flooding the unit with water or any liquid solution, particularly the electrical control panel and motor areas. Severe damage or electrical hazard could result, voiding the warranty.

SANITATION GUIDELINES

Food flavor and aroma are usually so closely related that it is difficult, if not impossible, to separate them. There is also an important, inseparable relationship between cleanliness and food flavor. Cleanliness, top operating efficiency, and appearance of equipment contribute considerably to savory, appetizing foods. Good equipment that is kept clean, works better and lasts longer.

Most food imparts its own particular aroma and many foods also absorb existing odors. Unfortunately, during this absorption, there is no distinction between GOOD and BAD odors. The majority of objectionable flavors and odors troubling food service operations are caused by bacteria growth. Sourness, rancidity, mustiness, stale or other OFF flavors are usually the result of germ activity.

The easiest way to insure full, natural food flavor is through comprehensive cleanliness. This means good control of both visible soil (dirt) and invisible soil (germs). A thorough approach to sanitation will provide essential cleanliness. It will assure an attractive appearance of equipment, along with maximum efficiency and utility. More importantly, a good sanitation program provides one of the key elements in the prevention of food-borne illnesses.

A controlled holding environment for prepared foods is just one of the important factors involved in the prevention of food-borne illnesses. Temperature monitoring and control during receiving, storage, preparation, and the service of foods are of equal importance.

INTERNAL FOOD PRODUCT TEMPERATURES		
HOT FOODS		
DANGER ZONE	40° TO 140°F	(4° TO 60°C)
CRITICAL ZONE	70° TO 120°F	(21° TO 49°C)
SAFE ZONE	140° TO 165°F	(60° TO 74°C)
COLD FOODS		
DANGER ZONE	ABOVE 40°F	(ABOVE 4°C)
SAFE ZONE	36°F TO 40°F	(2°C TO 4°C)
FROZEN FOODS		
DANGER ZONE	ABOVE 32°F	(ABOVE 0°C)
CRITICAL ZONE	0° TO 32°F	(-18° TO 0°C)
SAFE ZONE	0°F OR BELOW	(-18°C OR BELOW)

The most accurate method of measuring safe temperatures of both hot and cold foods is by internal product temperature. A quality thermometer

is an effective tool for this purpose, and should be routinely used on all products that require holding at a specific temperature.

A comprehensive sanitation program should focus on the training of staff in basic sanitation procedures. This includes personal hygiene, proper handling of raw foods, cooking to a safe internal product temperature, and the routine monitoring of internal temperatures from receiving through service.

Most food-borne illnesses can be prevented through proper temperature control and a comprehensive program of sanitation. Both these factors are important to build quality service as the foundation of customer satisfaction. Safe food handling practices to prevent food-borne illness is of critical importance to the health and safety of your customers. HACCP, an acronym for Hazard Analysis (at) Critical Control Points, is a quality control program of operating procedures to assure food integrity, quality, and safety. Taking steps necessary to augment food safety practices are both cost effective and relatively simple. While HACCP guidelines go far beyond the scope of this manual, additional information is available by contacting the USDA/FDA Food-borne Illness Education Information Center at (301)504-6803.

GENERAL HOLDING GUIDELINE

Chefs, cooks and other specialized food service personnel employ varied methods of cooking. Proper holding temperatures for a specific food product must be based on the moisture content of the product, product density, volume, and proper serving temperatures. Safe holding temperatures must also be correlated with palatability in determining the length of holding time for a specific product.

Halo Heat maintains the maximum amount of product moisture content without the addition of water, water vapor, or steam. Maintaining maximum natural product moisture preserves the natural flavor of the product and provides a more genuine taste. In addition to product moisture retention, the gentle properties of Halo Heat maintain a consistent temperature throughout the cabinet without the necessity of a heat distribution fan, thereby preventing further moisture loss due to evaporation or dehydration.

In an enclosed holding environment, too much moisture content is a condition which can be relieved. A product achieving extremely high temperatures in preparation must be allowed to decrease in temperature before being placed in a controlled holding atmosphere. If the product is not allowed to decrease in temperature, excessive condensation will form increasing the moisture content on the outside of the product.

Most Halo Heat Holding Equipment is provided with a thermostat control between 60° and 200°F (16° to 93°C). If the unit is equipped with vents, close the vents for moist holding and open the vents for crisp holding.

HOLDING TEMPERATURE RANGE		
	FAHRENHEIT	CELSIUS
MEAT		
BEEF ROAST — Rare	140°F	60°C
BEEF ROAST — Med/Well Done	160°F	71°C
BEEF BRISKET	160° — 175°F	71° — 79°C
CORN BEEF	160° — 175°F	71° — 79°C
PASTRAMI	160° — 175°F	71° — 79°C
PRIME RIB — Rare	140°F	60°C
STEAKS — Broiled/Fried	140° — 160°F	60° — 71°C
RIBS — Beef or Pork	160°F	71°C
VEAL	160° — 175°F	71° — 79°C
HAM	160° — 175°F	71° — 79°C
PORK	160° — 175°F	71° — 79°C
LAMB	160° — 175°F	71° — 79°C
POULTRY		
CHICKEN — Fried/Baked	160° — 175°F	71° — 79°C
DUCK	160° — 175°F	71° — 79°C
TURKEY	160° — 175°F	71° — 79°C
GENERAL	160° — 175°F	71° — 79°C
FISH/SEAFOOD		
FISH — Baked/Fried	160° — 175°F	71° — 79°C
LOBSTER	160° — 175°F	71° — 79°C
SHRIMP — Fried	160° — 175°F	71° — 79°C
BAKED GOODS		
BREADS/ROLLS	120° — 140°F	49° — 60°C
MISCELLANEOUS		
CASSEROLES	160° — 175°F	71° — 79°C
DOUGH — Proofing	80° — 100°F	27° — 38°C
EGGS — Fried	150° — 160°F	66° — 71°C
FROZEN ENTREES	160° — 175°F	71° — 79°C
HORS D'OEUVRES	160° — 180°F	71° — 82°C
PASTA	160° — 180°F	71° — 82°C
PIZZA	160° — 180°F	71° — 82°C
POTATOES	180°F	82°C
PLATED MEALS	180°F	82°C
SAUCES	140° — 200°F	60° — 93°C
SOUP	140° — 200°F	60° — 93°C
VEGETABLES	160° — 175°F	71° — 79°C

The holding temperatures listed are suggested guidelines.

MOTOR DRIVE CONTROL OPERATION

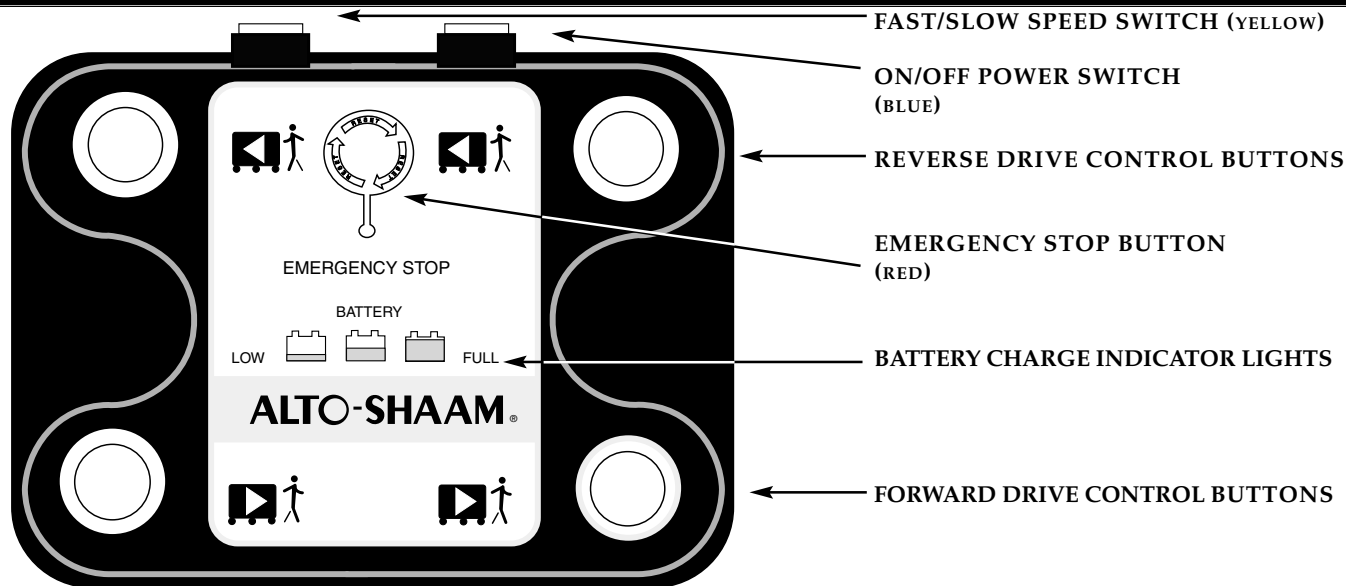

MOTOR DRIVE CONTROL

A two-speed Motor Drive Control is located at both ends of the cart to propel the unit in both forward and reverse. Slow speed is 0.9 mph (1.4 km/hr) and fast speed is 1.9 mph (3.1 km/hr).

ON/OFF POWER SWITCH

The ON/OFF power switch (BLUE) controls the Motor Drive Control and is located at the top of the drive control housing at one end of the cart only. To engage the drive control press the ON/OFF power switch to the "ON" position. Allow 2 to 3 seconds for control to initialize before using Forward/Reverse Control buttons.

FAST/SLOW SPEED SWITCH

The yellow FAST/SLOW speed switch is located left of the ON/OFF Power Switch. To engage Fast Speed, depress the yellow switch – the switch will illuminate. For best results, start in Slow Speed. The cart will accelerate to speed within 3 to 4 seconds. Once cart is moving – engage Fast Speed. This will minimize cart "surge".

REVERSE DRIVE CONTROL BUTTONS

The reverse drive control buttons are located toward the top of the drive control housing. Pressing either of these buttons will move the cart in reverse or away from the operator.

EMERGENCY STOP BUTTON

When pushed, the red emergency stop button completely disengages the motor drive control and will immediately halt all cart movement. To restore motor drive function, turn and release the emergency stop button in a clockwise direction.

BATTERY INDICATOR LIGHTS

When the motor drive control switch is in the "ON" position, a battery light will illuminate indicating the condition of the battery charge: RED, **low**; YELLOW, **medium**; or GREEN, **full**. To recharge the battery when indicating a medium or low charge, connect the cart to the power source until the charge is restored (one hour minimum). If battery charge is insufficient to maintain the cart through the service period or while en route, the motor drive assembly brake must be released and the cart manually moved to a power source. (SEE SECTION TITLED

MOTOR DRIVE FOR DETAILED INSTRUCTIONS.)

FORWARD DRIVE CONTROL BUTTONS

The forward drive control buttons are located toward the bottom of the drive control housing. Pressing either of these buttons will move the cart forward or toward the operator.

MOTION BEEPER, HORN

There is an audible signal whenever the drive control is engaged in either a forward or reverse motion.

IMPORTANT

FOR THE SAFEST METHOD OF OPERATION, A CART OPERATOR SHOULD ALWAYS BE POSITIONED AT THE FRONT OF THE CART IN WHICHEVER DIRECTION THE CART IS MOVING.



AS A SAFETY PRECAUTION DO NOT GUIDE CART FROM THE BACK. GUIDE THE UNIT TO DESTINATION BY PULLING FROM EITHER END OF THE CART.

To keep drive batteries fully charged, the cart must remain connected to the power source when not in service. Turn drive system power switch OFF when not in use.

MOTOR DRIVE BRAKE

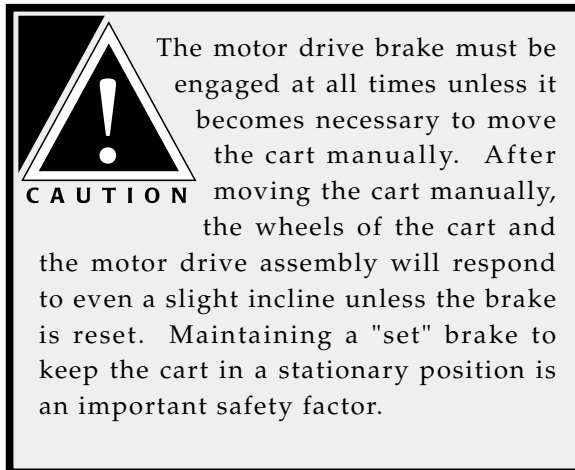

**IF DRIVE
BATTERY
LOSES →
CHARGE
IN
TRANSIT
—
DISENGAGE
BRAKE**

1. Move handle of brake clockwise to the OFF position.
2. Position an operator at the front to guide the cart while another operator manually pushes from the back.
3. Move the cart to an appropriate outlet and connect power cord for a minimum of 30 minutes. For a full charge, cart must be connected to the power source for a minimum of 1 hour.
4. Following recharge period, make certain the brake handle has been turned counter-clockwise to the *on* position and continue cart use.

ALWAYS OBSERVE THE MOTOR DRIVE BRAKE SAFETY PRECAUTIONS.

***EXTENDED STORAGE:** When removed from active service, the unit can remain continuously connected to power up to a maximum of 30 days to maintain full battery charge. Turn the Drive System Power Switch OFF when not in use. See Extended Storage & Battery Charging section of this manual.*

MOTOR DRIVE BRAKE

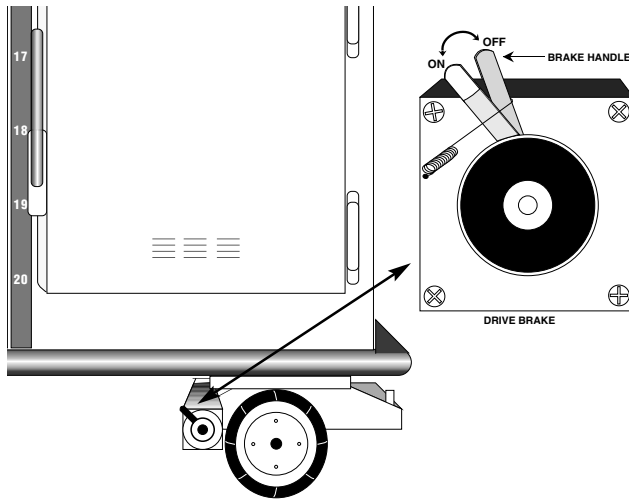

IF DRIVE BATTERY LOSES CHARGE IN TRANSIT, DISENGAGE BRAKE

1. Move handle of brake clockwise to the **OFF** position. Turn Drive System Power Switch **OFF**.
2. Manually push the cart to an appropriate outlet and connect power cord for a minimum of 30 minutes. *FOR A FULL CHARGE, CART MUST BE CONNECTED TO THE POWER SOURCE FOR A MINIMUM OF 1 HOUR.*
3. Following recharge period, move brake handle counter-clockwise to the **ON** position.

To keep batteries fully charged, the cart must remain connected to the power source when not in service. Turn Drive System Power Switch **OFF** when not in use.

BATTERY CHARGER

The battery charger is located on the Motor Drive Assembly. The charger includes one bi-color indicator light to show the charging state of the battery.

- A. The yellow light indicates the charger is in operation but the motor drive battery has not yet reached full charge.
- B. A green light indicates the battery has reached full charge. Charger can operate indefinitely without harming the battery.

CART FREEWHEELING and DRIVE SAFETY FEATURES

To freewheel the cart manually, the Drive Power Switch must be **OFF** – then the Drive Brake must be placed in the **OFF** position. See Drive Brake Caution below. Restore the Drive Brake to the **ON** position upon freewheeling completion.

ALARM CONDITION No. 1

With the Drive Power Switch **ON** – and then the Drive Brake turned **OFF** – the drive unit provides dynamic braking (movement is possible, but difficult). If either Forward/Reverse Drive Control Buttons are depressed, the motion beeper will sound an alarm and the Drive Motor will not operate. To clear the alarm and restore operation, turn the Drive Brake **ON**.

ALARM CONDITION No. 2

If the Drive Power Switch and Drive Brake are both **OFF** – then the Drive Power Switch is turned **ON**, the motion beeper will sound an alarm and the drive motor will not operate. To clear the alarm and restore operation, turn the Drive Brake **ON**, then turn the Drive Power Switch **OFF** and then **ON** again.

ALARM CONDITION No. 3

If either Forward or Reverse Drive Control Button is depressed and the Drive Power Switch is turned **ON**, the motion beeper will sound an alarm and the drive motor will not operate - **OR** - if either Forward or Reverse Drive Control Button is depressed immediately after the Drive Power Switch is turned on, the motion beeper will sound an alarm and the drive motor will not operate.

ALARM CONDITION No. 4

If the cart power cord is connected to power and then the Drive Power Switch is turned **ON**, the motion beeper will sound an alarm, the green “full” battery indicator light will flash, and the drive motor will not operate. To clear the alarm and restore operation, disconnect the cart power cord from the power supply; turn the Drive Power Switch **OFF** for 5 seconds and then turn it **ON** again.

ALARM CONDITION No. 5

If the Drive Power Switch is **ON**, and the cart power cord is connected to power, the green “full” battery indicator light will flash. If either Forward/Reverse Drive Control Button(s) are depressed, the motion beeper will sound an alarm and the drive motor will not operate. To clear the alarm and restore operation, disconnect the cart power from the power source; turn the Drive Power Switch **OFF** for 5 seconds and then turn it **ON** again.

Drive Brake • Caution

The motor drive brake must be engaged at all times unless it becomes necessary to move the cart manually. After moving the cart manually, the wheels of the cart and the motor drive assembly will respond to even a slight incline unless the brake is reset. Maintaining a “set” brake to keep the cart in a stationary position is an important safety factor.



HOT/COLD FOOD DELIVERY SYSTEM

MODEL 1400-DC EXTERIOR DIMENSIONS

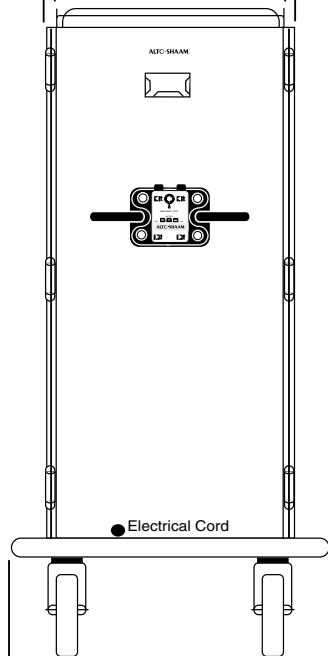
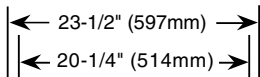
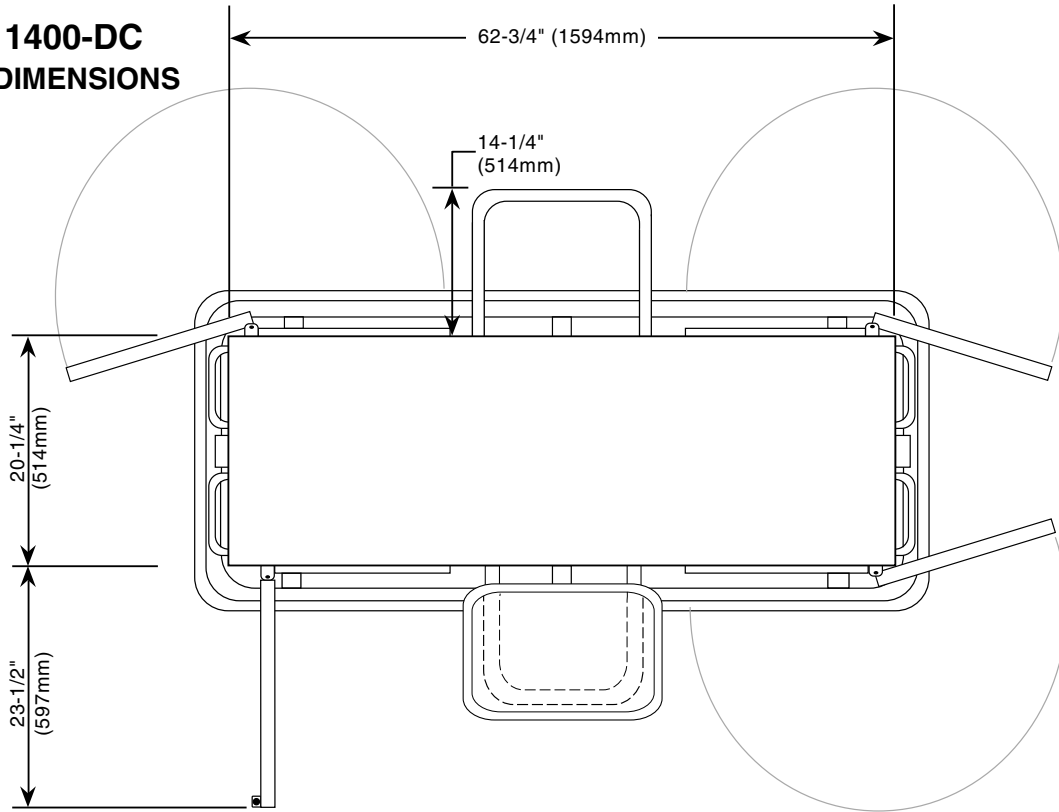

FULL-SIZE TRAY STORAGE AREA

15-15/16" Wide x 8-3/4" High
(405mm x 222mm)

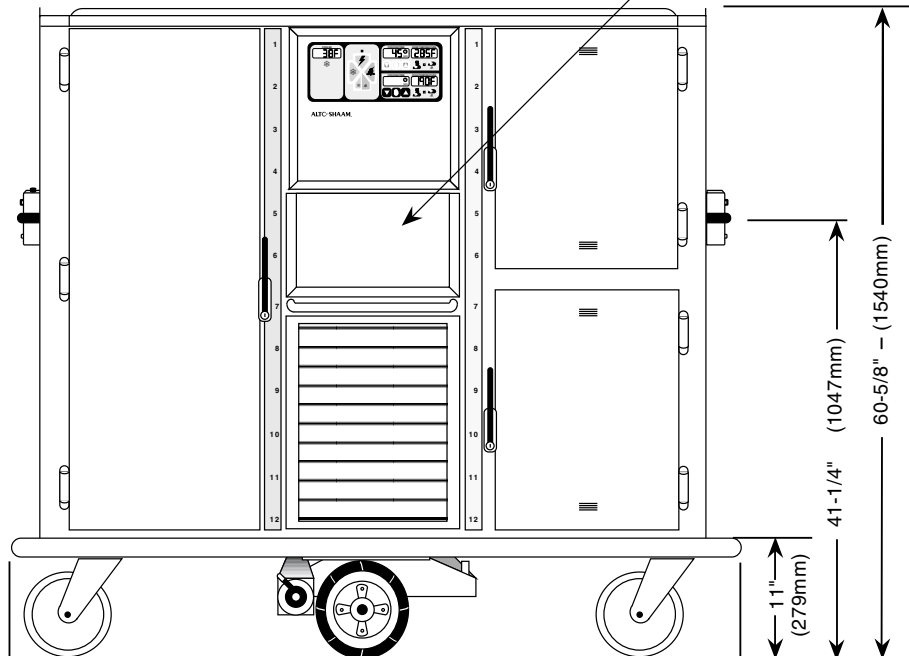

SERVICE SECTION

The primary purpose of the service section of this manual is to provide the service technician with helpful information regarding basic service to the Alto-Shaam Delivery Cart. It is not intended to be a refrigeration or heating system textbook. For detailed compressor or condenser information, consult the *Copeland Service Manuals*. For major repairs to the Delivery Cart, contact an authorized service facility or the factory.

TEMPERATURE CALIBRATION

OVEN COMPARTMENTS

The oven thermostat is part of the electronic control, therefore, no adjustment or calibration is ever necessary. The fixed temperatures for both cooking (reheating) and holding are determined at the time of order and are set as *standard* or *special order* at the temperatures indicated in the section titled Temperature Controls, Heated Compartments

COLD COMPARTMENT

The refrigerator thermostat is preset at the factory and should not require adjustment.

REFRIGERATOR 38°F (3.3°C)

If it appears the refrigerator thermostat requires adjustment, contact the factory or an authorized factory service agency.

SENSORS

Sensors for the oven compartments and the refrigerator compartment are mounted on the side wall of each respective compartment, behind the tray side racks

To verify the actual compartment temperature with the temperature indicated on the digital display of the control panel, check the air temperature within the compartment with a quality thermal indicator.

1. Make certain all sensors are clean and undamaged.
2. Load the empty trays into each compartment.
3. Position the end of the thermal indicator to be used for testing in the center of the compartment to be tested. On 1400-DC/20 models, placement is between the 2nd and 3rd tray. Placement for 1400-DC/24 models is between the 3rd and 4th tray.

4. Allow one (1) hour for the compartment temperature to stabilize before comparing the digital display on the control panel with the thermal indicator. Do *not* open the compartment doors during this test procedure.

NOTE: The compartment temperatures indicated on the digital display of the unit control panel will continuously fluctuate within several degrees of the fixed compartment temperatures. THIS IS A NORMAL OPERATING CONDITION. The mid point between the high and low reading should be considered as the actual compartment temperature.

If the temperature on the thermal indicator does not match the digital display for that compartment, the fault may lie in the sensors, sensor wiring, or electronic control.

To check the sensors, test the resistance with a quality ohm meter on the low-ohms scale. Take the reading at the sensor connections. Remove the sensor and place in an ice water bath (32°F or 0°C). The resistance should be approximately 100 ohms.



CIRCUIT BREAKER

The circuit breaker for the 1400-DC delivery cart is accessible through the tray storage area located on the bottom surface of the control compartment. For cart operation the circuit breaker switch must be in the ON position.

The current draw should be checked with an amp meter and the reading compared with the unit electrical rating. The reading on the amp meter should not exceed 30 amps. If the amp meter indicates a correct reading, the circuit breaker is defective and must be replaced.

HEATING ELEMENTS

Element lead wires can be accessed at the terminal block located behind the electronic control box. Continuity of the cable heating elements should be checked with an ohm meter from each element to ground. THERE SHOULD BE NO CONTINUITY TO GROUND. If there is continuity to ground, replace the shorted element.

Check the resistance of each element separately. Cable resistance is approximately .66 ohms/foot (305mm). The resistance should measure between 18.9 and 22.0 ohms. If the element resistance is very high or low, replace the defective length of element.

If only one length of cable requires replacement, check the other element for signs of deterioration and replace at the same time.

ELECTRONIC CONTROL

Before attempting to replace the electronic control, make certain the problem is in the control and not in another area of the unit. Check all other items listed in the Service Section of this manual. If all is in order, check to make certain electrical power is reaching the control and that the control inter-connectors are secure. For major repairs, contact an authorized service facility or the factory.

SERVICE SECTION

1400-DC ELECTRONIC CONTROL REPLACEMENT INSTRUCTIONS

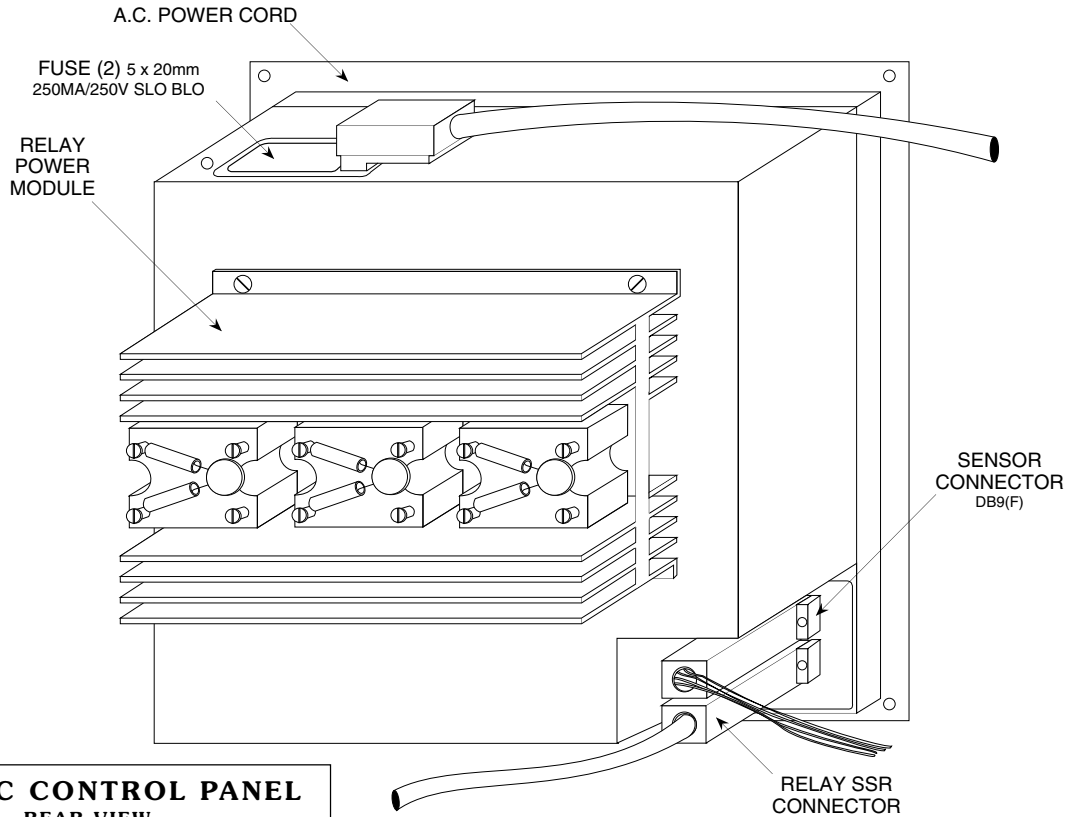

1400-DC CONTROL PANEL
REAR VIEW

1. Press the power switch on the Delivery Cart control panel to the **OFF** position.
2. Disconnect the electrical power cord from the power source.
3. Remove the glass control panel door on models so equipped. Fully open door and lift up to disengage hinges.
4. Remove the four (4) mounting screws at the front of the control.
5. Carefully move the control forward, as far as the connecting wires will allow.
6. Remove the A.C. power cord on the control by pulling up on the plug.
7. Loosen the two (2) side mounting screws on the sensor connector. Unplug the sensor connector at the back of the control.
8. Check the model number located on the top of the control and compare it with the replacement control to assure compatibility.
9. Remove old control from unit.
10. Install the new control in the reverse order. Use caution when handling the new control to prevent damage to the keypad or the overlay panel surface.
11. Do not over-tighten the two sensor or relay connector side-mounting screws.
12. Caution must be used when installing the new control to prevent pinching, nicking, or cutting the connection wires.
13. Check the function of the replacement control by operating the delivery cart according to the General Operating Instructions.
14. These instructions are intended for the replacement of controls of the same type and model. Special instructions are required for retrofitting an electronic timer control in place of a control with a rotating timer.

CAUTION

ALWAYS DISCONNECT
FOOD DELIVERY CART
FROM THE POWER
SOURCE BEFORE
CLEANING OR SERVICING.



CAUTION

SERVICE SECTION

REFRIGERATION

The only source for complete compressor information is the serial plate located directly on the compressor. The serial plate compressor model number nomenclature is indicative of the following specifications:

If the compressor does not start, starts and runs continuously or short-cycles and there are no obvious causes, consult the *Copeland Compressor Service Manual* for helpful information regarding full service to the compressor.

If the refrigerator compartment does not reach temperature, check the Refrigerant Sight Glass located in the refrigerator compartment. Remove the cold compartment tray side rack with the 3" (76mm) return for access to the Refrigerant Sight Glass.

When the unit is fully charged, the sight glass will appear clear and the center indicator will be green. If there is a leak and the line is empty, the sight glass will have bubbles and the center indicator may be yellow. If consistent bubbles are seen while the machine is running, unit is short of refrigerant or the TXV valve may be out of adjustment or defective..

MODEL 1400-DC

The cooler uses a TXV valve to meter the flow of refrigerant into the evaporator coil. There is a low pressure safety switch located in the suction line to help protect the compressor in case of a refrigerant leak.

If the compressor will not start, locate the leads of the low pressure safety switch and bypass the connection. If the compressor starts at this point, a refrigerant leak is evident. This leak must be repaired and the system must be evacuated and recharged.

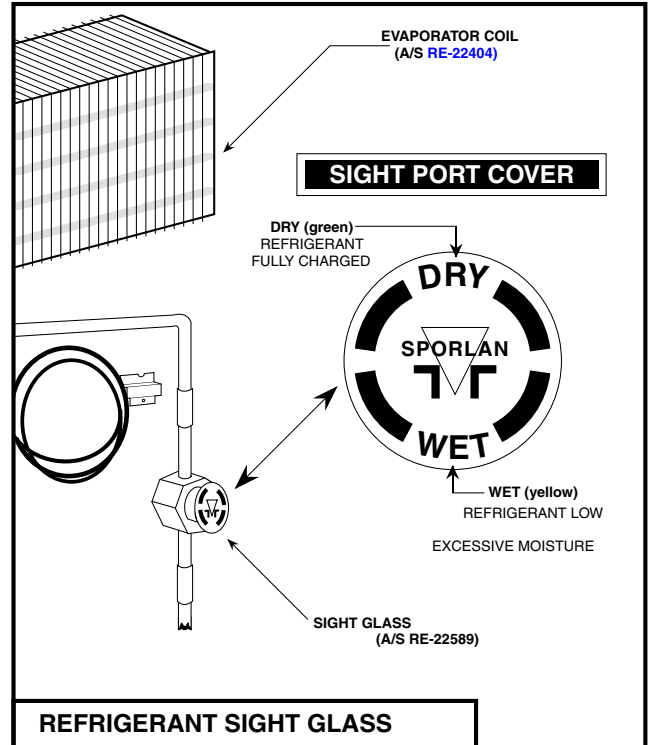
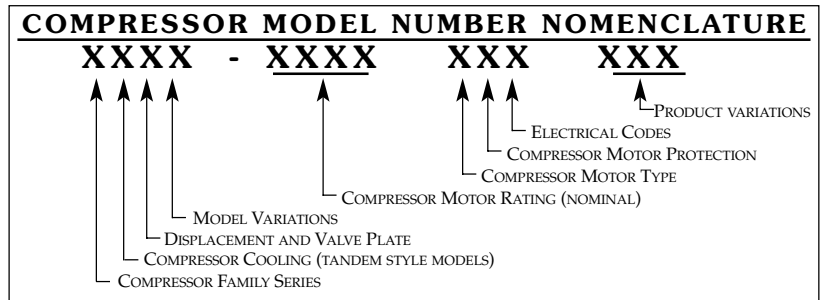

CAUTION

ALWAYS DISCONNECT THE FOOD DELIVERY CART FROM THE POWER SOURCE BEFORE CLEANING OR SERVICING.

DOOR ADJUSTMENT

The doors on all compartments of the delivery cart have been adjusted at the factory to provide a proper seal. Routine maintenance of the delivery cart should include a periodic examination of the door gasket to make certain a good seal is maintained. Proper adjustment can be tested by pulling a dollar bill through the gasket seal and feeling a slight resistance.

Minor adjustment to the doors is made at the hinges in one direction — IN and OUT. There is no need to adjust the doors up-and-down, or side-to-side.

For in-and-out adjustment, loosen the three (3) screws holding the plate to the door hinge. Move the door OUTWARD to LOOSEN the gasket seal or INWARD to TIGHTEN the gasket seal. The adjustment faces are grooved so that movement is fixed when the screws are retightened. Adjust the hinges so that the door face and the unit face are parallel, and the portion of the gasket at the hinge-side does not bind when the door closes. Following adjustment, retest for proper seal as indicated above.

HOT/COLD FOOD DELIVERY SYSTEM

TROUBLE SHOOTING GUIDE

PROBLEM	POSSIBLE CAUSE	REMEDY
Dietary Cart does not operate	<ol style="list-style-type: none"> 1. No electrical power 2. Defective cord or plug 3. Circuit breaker tripped 4. Power switch defective 5. Defective control 	Check power source Repair or replace Reset Replace Replace
Compressor does not operate — all other functions operate	<ol style="list-style-type: none"> 1. Blown fuse 2. Low voltage 3. Faulty circuit 4. Defective compressor 5. Defective control 6. Defective transformer 	Replace fuse Check power source Check circuitry Replace Replace Replace
Circuit breaker trips	<ol style="list-style-type: none"> 1. Power source not matched to unit 2. Faulty wiring 3. Breaker defective 4. Refrigeration unit defective 5. Compressor overheating 6. Compressor motor shorted 7. Heating element shorted 8. Defective control 	Relocate unit to proper power source Repair Replace Repair or replace Check refrigeration system Replace compressor Replace Replace
Compressor operates too long or operates continuously	<ol style="list-style-type: none"> 1. Defective evaporator blower motor 2. Condenser dirty 3. Exhaust fan not operating 4. Air vents restricted 5. Excessive load in refrigerator 6. Evaporator iced due to continuous operation 7. Refrigeration system faulty 8. Low refrigerant (bubbles in sight-glass) 	Replace evaporator blower motor Clean condenser coil and grill Replace Allow adequate ventilation space Follow prescribed procedures Shut unit OFF to deice Repair or replace Charge system
Compressor operates in short cycles	<ol style="list-style-type: none"> 1. Refrigeration system faulty 2. Defective sensor(s) 3. Control too hot 	Repair or replace Replace Check cooling fan for obstruction
Refrigerator not maintaining temperature	<ol style="list-style-type: none"> 1. Door seals 2. Fan not operating 3. Bent or defective sensor 4. Refrigeration system faulty 5. Defective Control 6. Low refrigerant 	Adjust doors — Clean or replace gasket Replace Replace Repair or replace Repair or replace Recharge compressor
Unit not reheating or holding properly	<ol style="list-style-type: none"> 1. Power source not matched to unit 2. Operating procedure 3. Heating element open or shorted 4. Loose door seals 5. Oven sensor dirty 6. Oven sensor defective 7. Control defective 8. Bent or defective sensors 	Relocate unit to proper power source Check and follow prescribed guidelines Replace Adjust doors Clean Replace Replace Replace
Inaccurate temperature display	<ol style="list-style-type: none"> 1. Sensor wiring faulty 2. Bent or defective sensors 3. Control faulty 	Repair Replace Replace
Display Error Message - Hot Compartments 1. SenS 2. Hot	<ol style="list-style-type: none"> 1. Hot cavity sensor short circuited 2. Hot cavity sensor open Cavity temperature exceeds 360°F (182°C) — Defective sensor — Shorted Power Module 	Repair or replace sensor Repair or replace sensor Replace sensor Replace Power Module
Display Error Message - Cold Compartment 1. Cld 2. Hi	<ol style="list-style-type: none"> 1. Cold cavity sensor short circuited Shorted Power Module 2. Cold cavity sensor open 	Repair or replace sensor Replace Power Module Replace sensor
Display Error Message - Freezer 1. Hi 2. -8°F (-22°C)	<ol style="list-style-type: none"> 1. Freezer sensor open Defective compressor 2. Cold cavity sensor short circuited Shorted Power Module 	Repair or replace sensor Repair or replace sensor Repair or replace sensor Replace Power Module

1400-DC SERVICE VIEW PARTS LISTS

1400-DC/20 & 1400-DC/24 SERVICE VIEW

1-12-00

DESCRIPTION	QUANTITY	PART NUMBER	DESCRIPTION	QUANTITY	PART NUMBER
1. TOP ASSEMBLY	1	5949	6. COLD END PANEL	1	14097
— TOP MOUNTING SCREWS	2	SC-2425	— SMALL CARD HOLDERS (not shown)	2	12285
2. PERIMETER BASE ASSEMBLY, includes	1	4310	— CARD HOLDER MOUNTING ADHESIVE		
— BUMPER	1	BM-22417	LENGTH: 32" (812mm)	1	TA-22418
— BASE WELD ASSEMBLY	1	14886	7. HOT END PANEL	1	11986
— PERIMETER TUBE ASSEMBLY	1	14716	— END PANEL MOUNTING SCREWS	2	SC-2425
3. SWIVEL CASTERS	4	CS-22028	8. COLD TUBE SECTION		
4. MOTORIZED DRIVE SYSTEM	1	MO-33514	— SEE COLD TUBE PARTS LIST	—	—
— CASTER & MOTOR MOUNTING SCREWS	16	SC-22422	9. CENTER CAVITY SECTION		
— CASTER & MOTOR MOUNTING WASHERS	16	WS-2867	— SEE CENTER SECTION PARTS LIST	—	—
— CASTER & MOTOR MOUNTING NUTS	16	NU-2866	10. HOT TUBE SECTION		
5. "U" HANDLE	4	HD-22257	— SEE HOT TUBE PARTS LIST	—	—
— "U" HANDLE MOUNTING SCREWS	8	SC-22339			

1400-DC COLD TUBE SERVICE VIEW

5/21/99

DESCRIPTION	QUANTITY	PART NUMBER	DESCRIPTION	QUANTITY	PART NUMBER
1. COLD TUBE ASSEMBLY (1 phase)	1	5953	10. COLD DOOR	2	5947
COLD TUBE ASSEMBLY (3 phase)	1	5970	INSULATION	2	13077
— INCLUDES ITEMS 2 THROUGH 8			11. COLD DOOR HANDLE	2	HD-2565
2. INSULATION	2	13078	HANDLE MOUNTING SCREWS	8	SC-2073
INSULATION, SIDE	2	13079	HANDLE LATCH PLATE MOUNTING SCREWS	4	SC-2070
INSULATION STUDS	4	ST-23143	HANDLE INSULATION SLEEVE	2	SL-2642
INSULATION CUPS	4	CL-22259	12. COLD DOOR HINGE (1 pair per part number)	3	HG-22338
3. CORD (1 ph): 10' (3048mm)	1	CD-3304	HINGE TO UNIT MOUNTING SCREWS	18	SC-2713
CORD (3 ph): 10' (3048mm)	1	CD-3727	HINGE TO DOOR MOUNTING SCREWS	18	SC-2072
4. FAN	1	FA-3861	13. COLD DOOR GASKET	2	GS-23407
FAN MOUNTING SCREWS	1	SC-22268	14. DC/20 COLD TUBE NUMBER DECAL (blue-4 pcs)	1	PE-22399
5. SENSOR	1	SN-33541	DC/24 COLD TUBE NUMBER DECAL (blue- 4 pcs)	1	PE-22401
6. EVAPORATOR	1	RE-22404	15. CORD PLUG (1 ph)	1	PG-3735
EVAPORATOR MOUNTING SCREWS	4	SC-2332	16. DRIP PAN ASSEMBLY	1	4824
7. FAN SHROUD	1	11939	17. DC/20 FAN SIDE RACK	1	4338
FAN SHROUD MOUNTING SCREWS	4	SC-2332	DC/24 FAN SIDE RACK	1	4345
8. SIDE RACK MOUNTING STUDS	16	ST-2546	18. DC/20 SMALL SIDE RACK	2	11938
9. COLD TUBE TO BASE MOUNTING SCREWS	4	SC-22796	19. DC/24 SMALL SIDE RACK	2	11992
COLD TUBE TO BASE MOUNTING WASHERS	4	WS-2867			

1400-DC REFRIGERATION SPECIFICATIONS

COMPRESSOR: 1/2 HP
 Rated capacity (BTU/HR) 3600
 Voltage (nominal) 115
 Hertz/Phase 60 Hz/1 Ph
 Rated Load Amps (RLA) 6.6
 Thermally Protected Amps (LRA) 29.0
 Refrigerant R404A
 Design Pressure (PSIG): Low Side 150
 High Side 235

CAPACITIES:
 Refrigerator Charge (pounds) 1.80
 Oil Charge (ounces) 16
EVAPORATOR FAN:
 Voltage/Wattage/Hertz 230V/70W/60 Hz
 AIR CFM 240
LIQUID LINE FILTER DRIER:
 Flow Capacity (TONS) 2.1
TEMPERATURE CONTROLS:
 Refrigeration Range 37°F MEAN 33° to 40°F (c. +0,56° to 4°C)

HOT/COLD FOOD DELIVERY SYSTEM

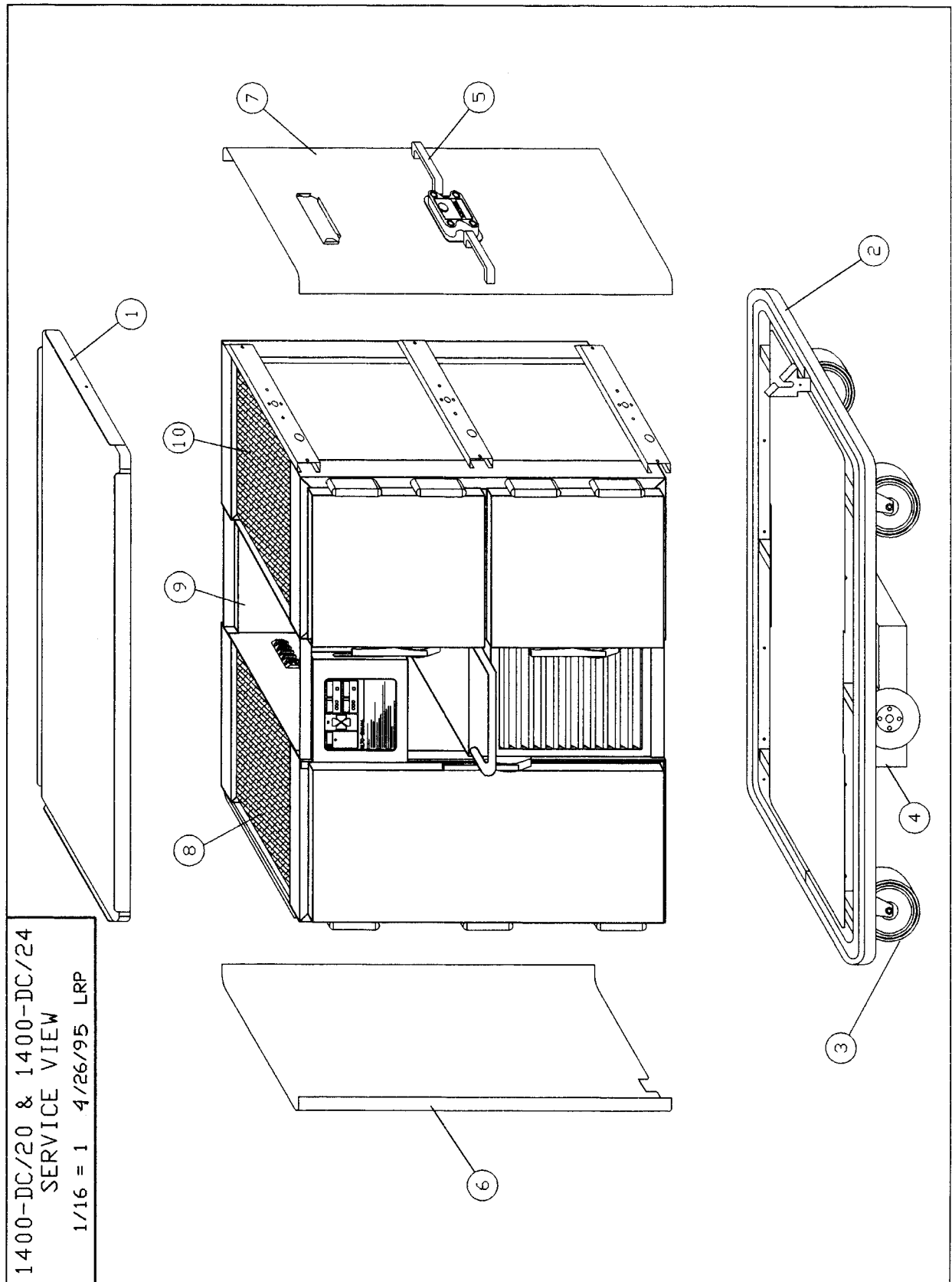

HOT/COLD FOOD DELIVERY SYSTEM

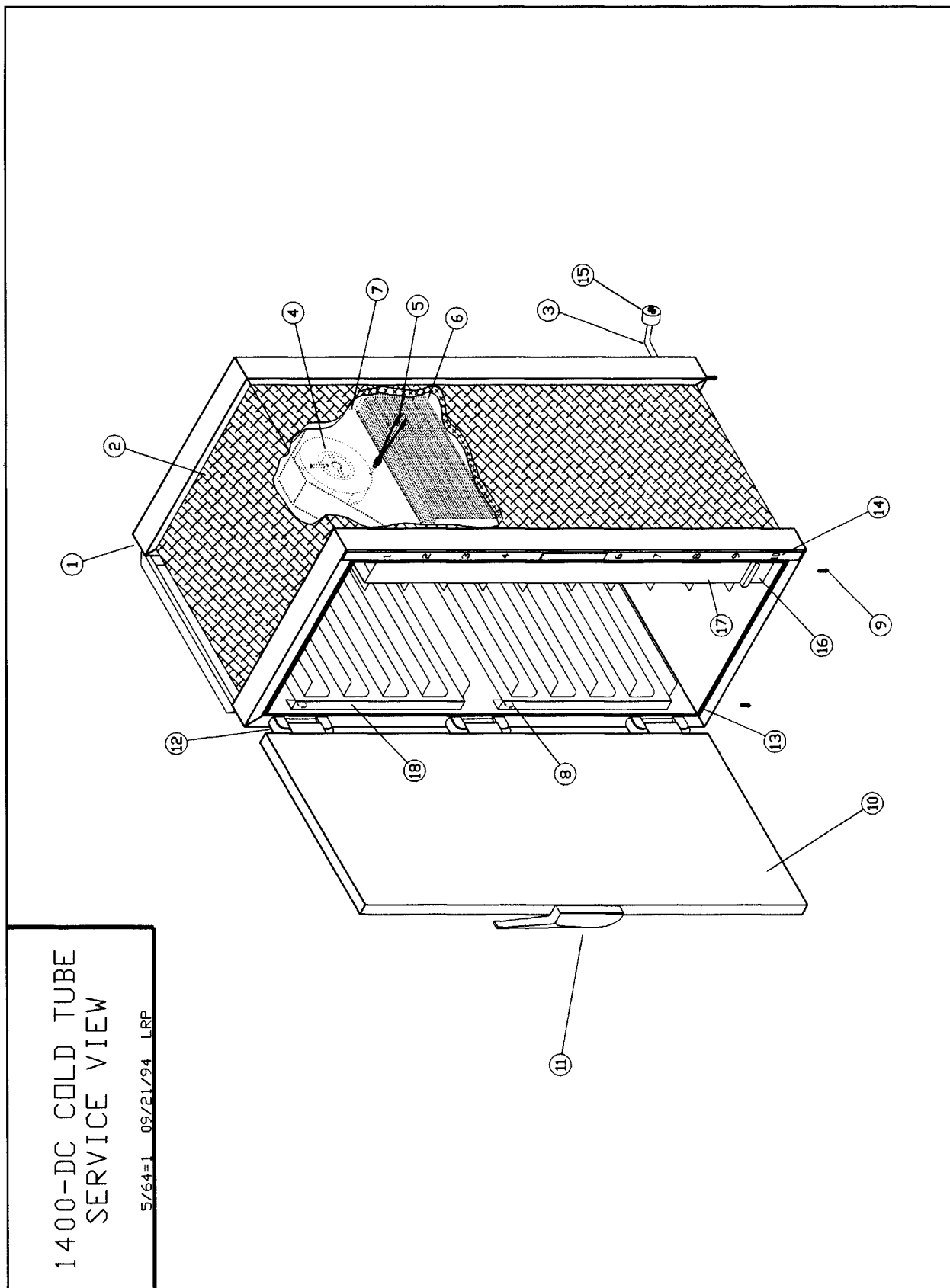

1400-DC SERVICE VIEW PARTS LISTS

1400-DC CENTER CAVITY SERVICE VIEW

4/7/99

DESCRIPTION	QUANTITY	PART NUMBER	DESCRIPTION	QUANTITY	PART NUMBER
1. CENTER CAVITY SUB ASSEMBLY	1	5954	8. CONTROL DOOR	1	5950
2. COMPRESSOR (50 Hz)	1	RE-22406	CONTROL DOOR GASKET	1	GS-23408
COMPRESSOR (60 Hz)	1	RE-22405	CONTROL DOOR GLASS	1	GL-22392
PRESSURE SWITCH	1	RE-22725	CONTROL DOOR HINGE	2	11578
3. TRANSFORMER (1 ph, 60 Hz only)	1	TN-3866	CONTROL DOOR MAGNETIC LATCH STRIKER	8	LT-2841
TRANSFORMER MOUNTING SCREWS	4	SC-2332	9. CONTROL DOOR UNIT MAGNETIC LATCH CATCH	1	LT-2840
TRANSFORMER MOUNTING NUTS	4	NU-2437	10. CONTROL WITH DEFROST	1	15744
TRANSFORMER LOCK WASHERS	4	WS-2294	PULSE ON, CE, 190F HOLD, 285F COOK, 1 PH	1	15750
TRANSFORMER WASHERS	4	WS-22094	PULSE OFF, CE, 180F HOLD, 265F COOK, 3 PH	1	15751
TRANSFORMER FUSES	2	FU-3911	PULSE OFF, FA, 190F HOLD, 285F COOK, 1 PH	1	15746
4. U-SHAPE TRAY SHELF	2	SH-22394	PULSE OFF, CE, 190F HOLD, 285F COOK, 1 PH	1	15747
TRAY SHELF GUIDE	4	GI-22395	PULSE OFF, CE, 190F HOLD, 285F COOK, 3 PH	1	15749
5. 30A CIRCUIT BREAKER SWITCH (1 ph)	1	SW-3715	CORD SET	1	CD-33076
20A CIRCUIT BREAKER SWITCH (3 ph)	1	SW-3728	SENSOR	1	5937
6. T-BLOCK	1	BK-2023	CONTROL MOUNTING SCREWS	4	SC-2425
7. VENT HOUSING	2	4333	11. HALF TRAYS (DC-20)	40	PN-22353
MAGNETIC LATCH	4	LT-23187	HALF TRAYS (DC-24)	48	PN-22353
			12. FAN	1	FA-3568
			13. BI-MET THERMOSTAT	1	TT-3562

1400-DC HOT TUBE SERVICE VIEW

5/20/96

DESCRIPTION	QUANTITY	PART NUMBER	DESCRIPTION	QUANTITY	PART NUMBER
1. HOT TUBE ASSEMBLY	1	5946	7. SIDE RACK MOUNTING STUDS	16	ST-2546
— INCLUDES ITEMS 2 THROUGH 7			8. HOT TUBE TO BASE MOUNTING SCREWS	4	SC-22796
2. SENSOR ASSEMBLY	2	4375	HOT TUBE TO BASE MOUNTING WASHERS	4	WS-2867
SENSOR MOUNTING HARDWARE	2	FT-22472	9. HOT DOOR	4	5948
3. HEATING CABLE:			10. HOT DOOR HANDLE	4	HD-2565
120' (36576mm) each compartment	2	CB-3045	HANDLE MOUNTING SCREWS	16	SC-2073
4. CABLE CONNECTION HARDWARE:			HANDLE LATCH PLATE MOUNTING SCREWS	8	SC-2070
CERAMIC SHOULDER BUSHING	8	BU-3105	HANDLE INSULATION SLEEVE	4	SL-2642
CERAMIC CUP BUSHING	8	BU-3106	11. HOT DOOR HINGE (1 pair per part number)	4	HG-22338
RING CONNECTOR	8	CR-3226	HINGE TO UNIT MOUNTING SCREWS	24	SC-2713
1-3/4" (c. 44mm) STUD	8	ST-2439	HINGE TO DOOR MOUNTING SCREWS	24	SC-2072
INSULATION SLEEVE	8	SL-3063	12. HOT DOOR GASKET	4	GS-23409
HEX NUT	48	NU-2215	13. DC/20 HOT TUBE NUMBER DECAL (red-4 pcs)	1	PE-22400
5. BI-METAL THERMOSTAT	4	TT-33079	DC/24 HOT TUBE NUMBER DECAL (red-4 pcs)	1	PE-22402
BI-METAL THERMOSTAT MOUNTING SCREWS	8	SC-2425	14. SPILL PAN	2	11977
BI-METAL THERMOSTAT MOUNTING NUTS	8	NU-22821	15. DC/20 SMALL SIDE RACK	4	11938
6. INSULATION	1	IN-22364	DC/24 SMALL SIDE RACK	4	11992

HOT/COLD FOOD DELIVERY SYSTEM

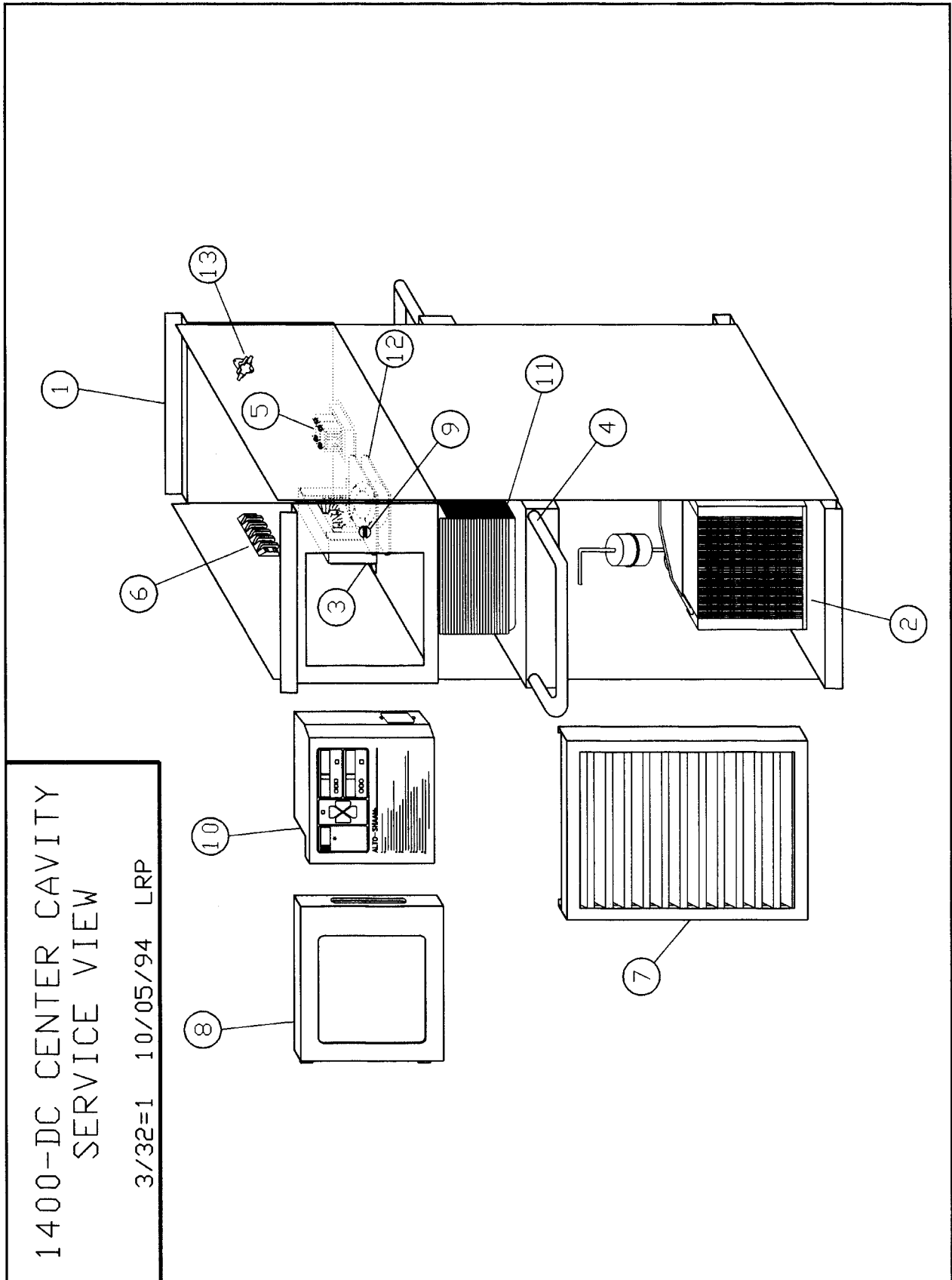

HOT/COLD FOOD DELIVERY SYSTEM

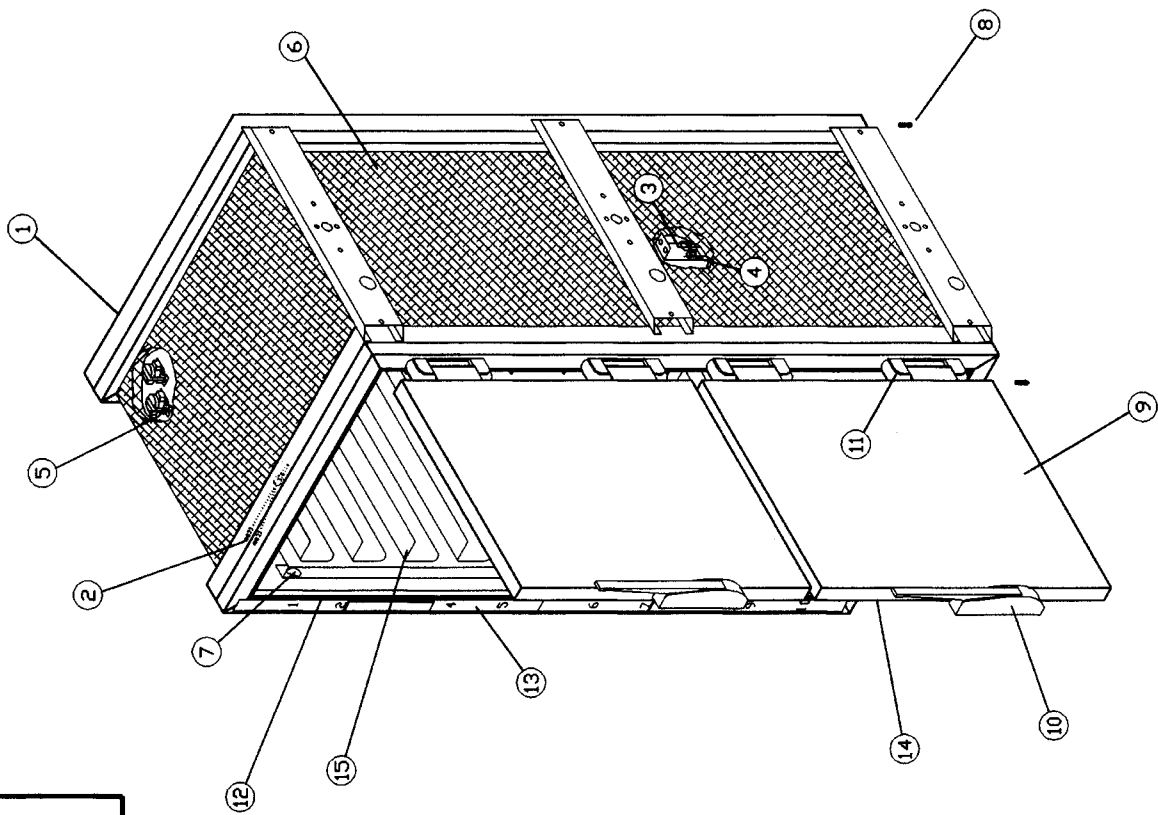

1400-DC HOT TUBE
SERVICE VIEW

5/64=1 10/10/94 LRP

1400-DC • Two Speed Drive Assembly Components

Parts List

<u>Description</u>	<u>Part Number</u>
Battery (two required)	BE-3889
Brake Assembly	BR-33628
Charger	CH-33524
Circuit Breaker - 30 Amp	CI-33531
Control Board for Handle Assembly A, B & C	BA-33636
Differential with motor/brake/sheels	DI-33629
Differential only	DI-33630
Drive Motor	MO-33576
Drive Motor Brushes	MO-33575
Fuse, 2 Amp	FU-33627
Handle Assembly "A", On/Off, Slow/Fast	HD-33525
Handle Assembly "B" (NO On/OFF)	HD-33529
Handle Assembly "C" Emergency Stop ONLY	HD-33530
Handle, Grip	HD-22257
Motion Beeper, Horn	HN-3898
Key, wheel/shaft lock	LK-33633
Main Control Module	CC-33532
Spring Cap	CP-33634
Spring	SP-33635
Switch - Yellow, Slow/Fast, Illuminated	SW-33526
Switch - White, Push button "Motion", Forward/Reverse	SW-33527
Switch - Blue, On/Off	SW-33528
Switch, Emergency Stop	SW-33032
Tire, 8.8" rubber	WH-33631
Tire Inner Tube	WH-33632
Wheel & Tire Assembly	WH-3896

Cable Heating Replacement Service Kit No. 4880

One for each cavity

includes:

CB-3045	Cable Heating Element	134 feet
CR-3226	Ring Connector	4
IN-3488	Insulation Corner	1 foot
BU-3105	Shoulder Bushing	4
BU-3106	Cup Bushing	4
SL-3063	Insulating Sleeve	4
TA-3540	High Temperature Tape	1 roll
ST-2439	Stud, 10/32	4
NU-2215	Hex Nut	8

CAUTION

ALWAYS DISCONNECT

FOOD DELIVERY

CART FROM THE

POWER SOURCE

BEFORE CLEANING OR

SERVICING.



HOT/COLD FOOD DELIVERY SYSTEM

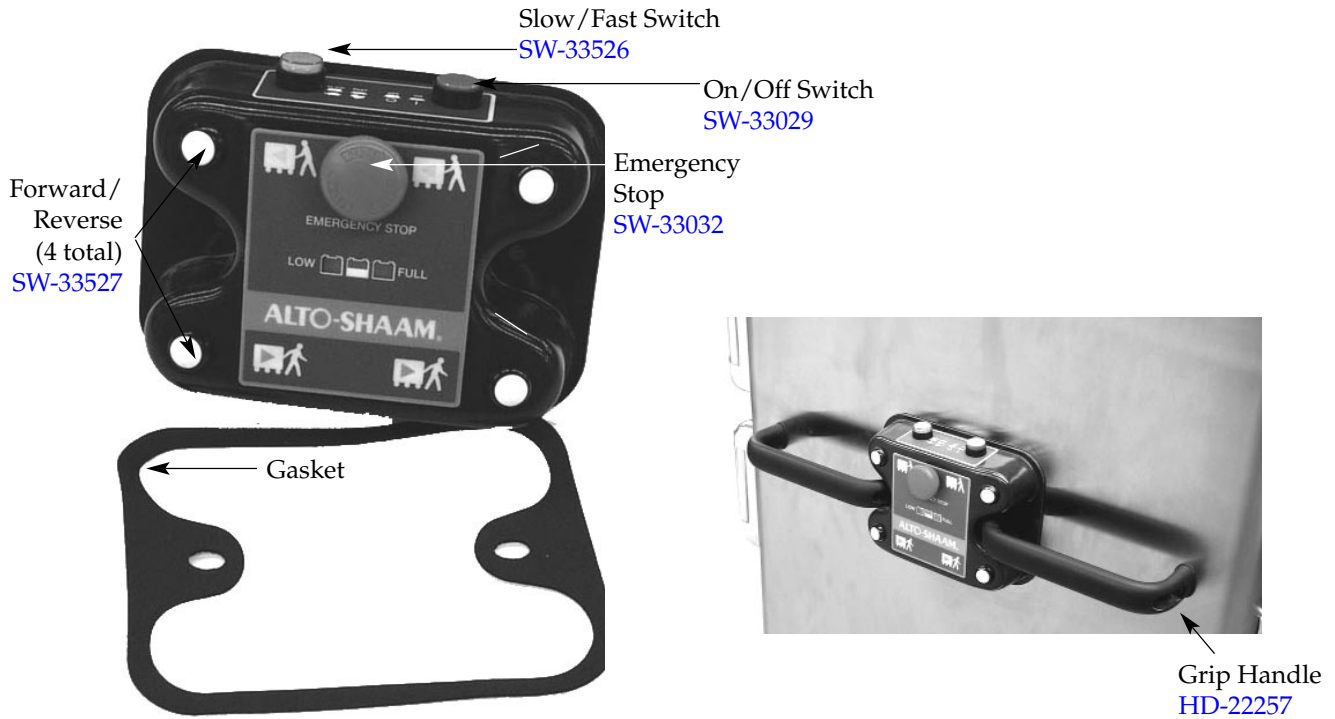

HANDLE "A" ASSEMBLY Front & Rear View HD-33525

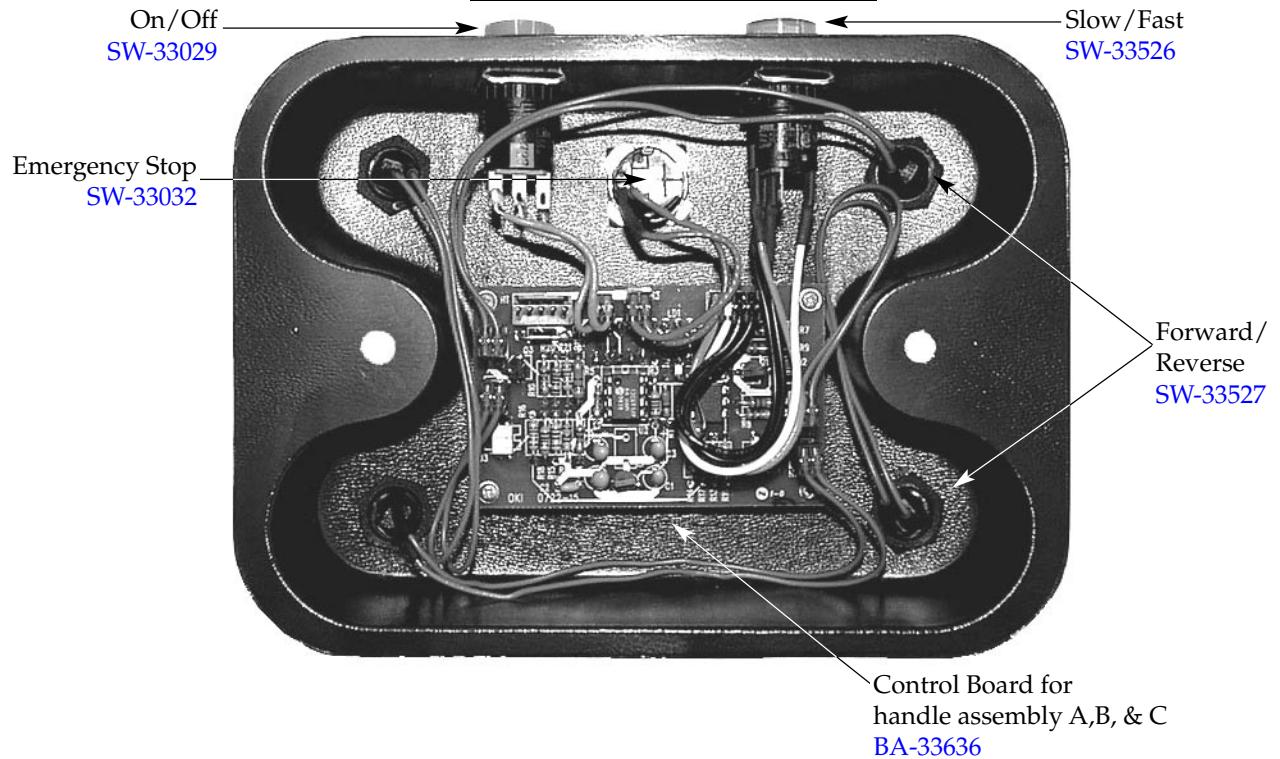

HOT/COLD FOOD DELIVERY SYSTEM



HANDLE ASSEMBLY "B" Front & Rear View HD-33529

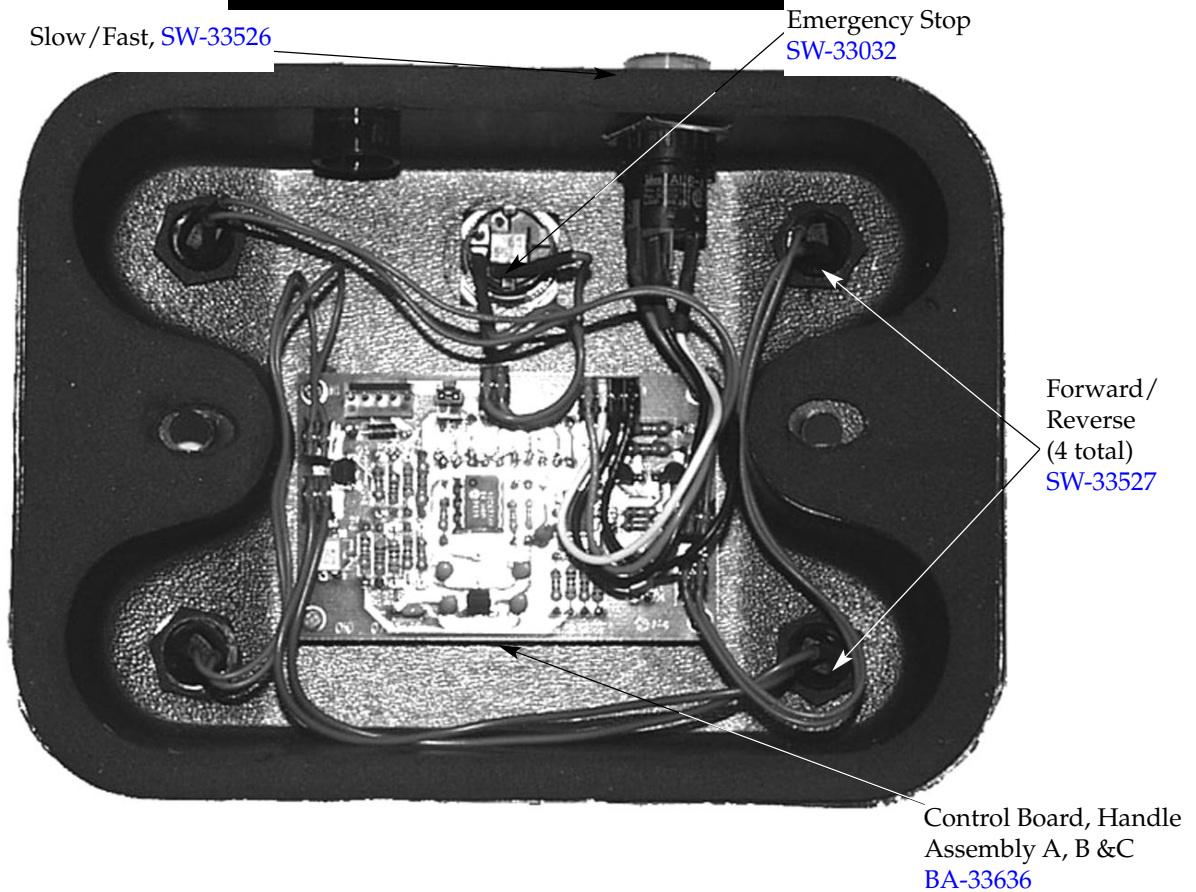

HOT/COLD FOOD DELIVERY SYSTEM

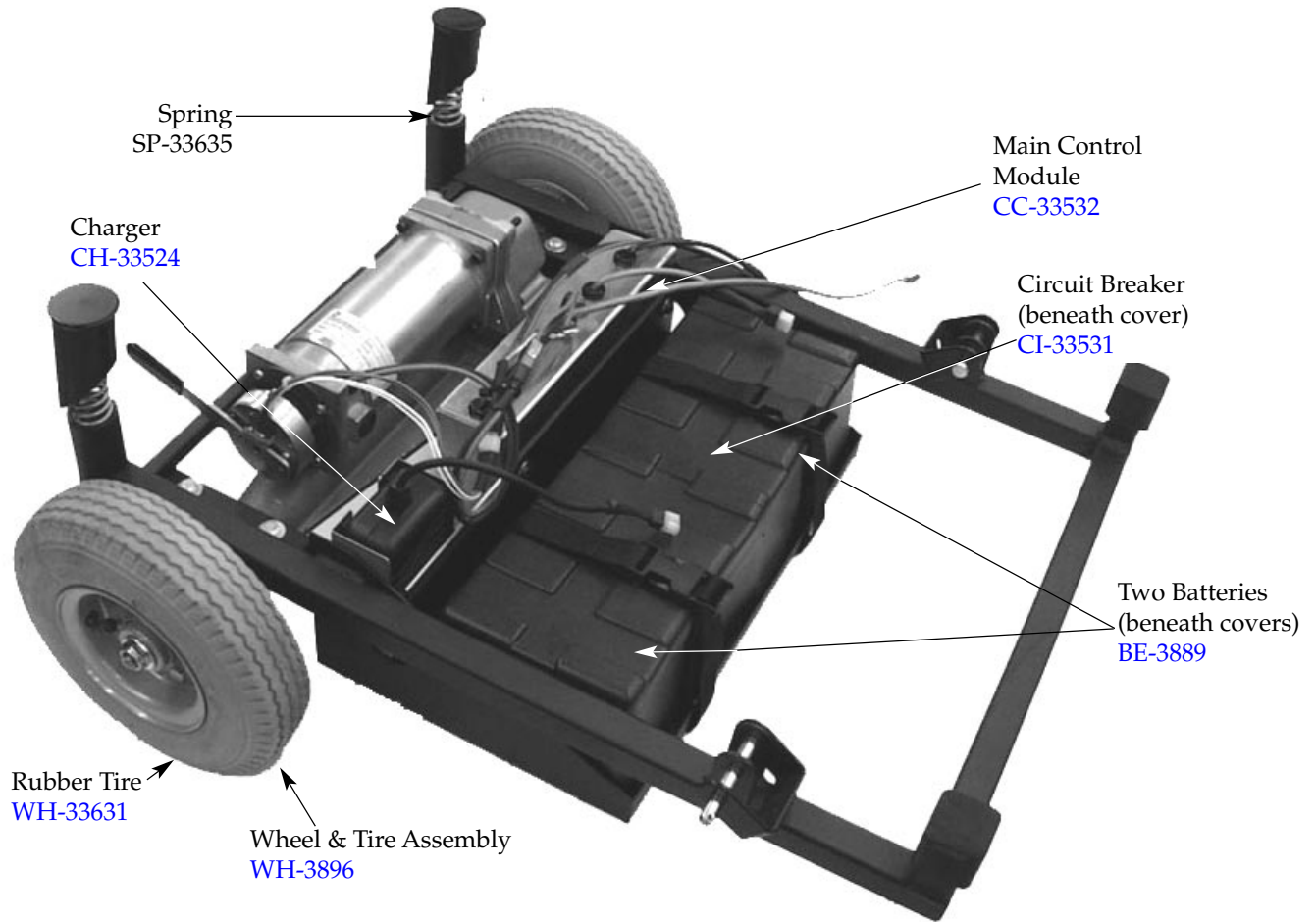

DRIVE ASSEMBLY Top & Bottom

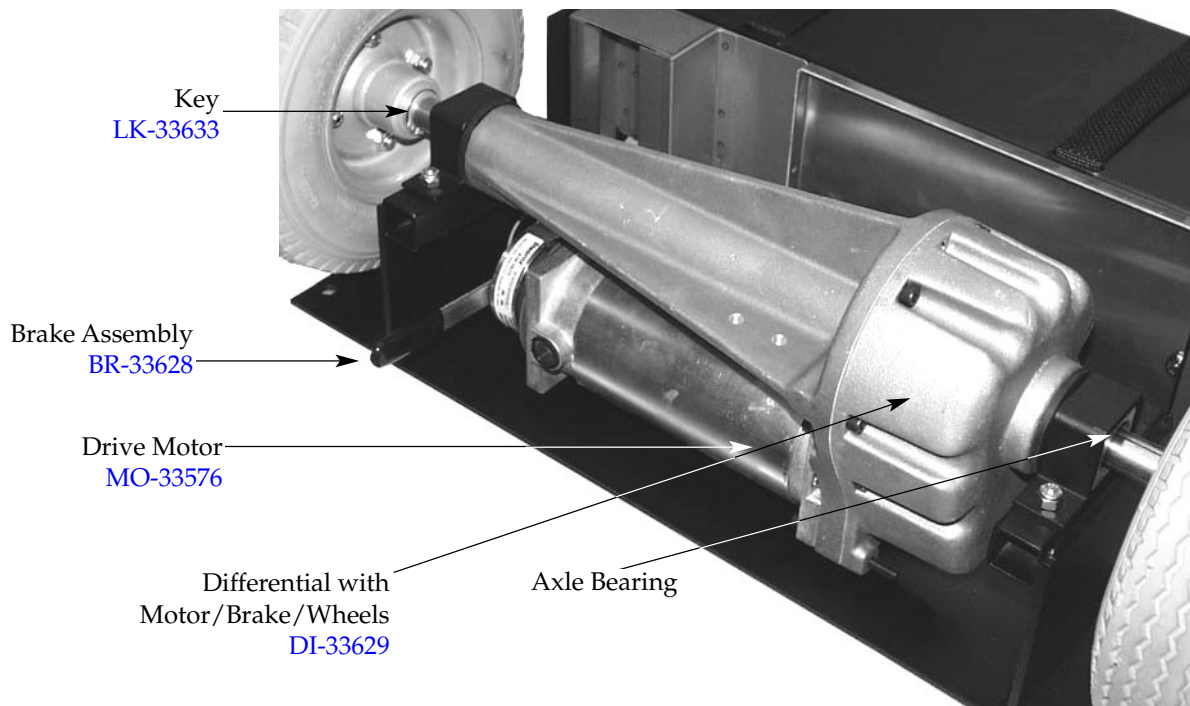

HOT/COLD FOOD DELIVERY SYSTEM

HANDLE ASSEMBLY "C" • HD-33530
for unit that has drive control one one side only



MAIN CONTROL MODULE • CC-33532

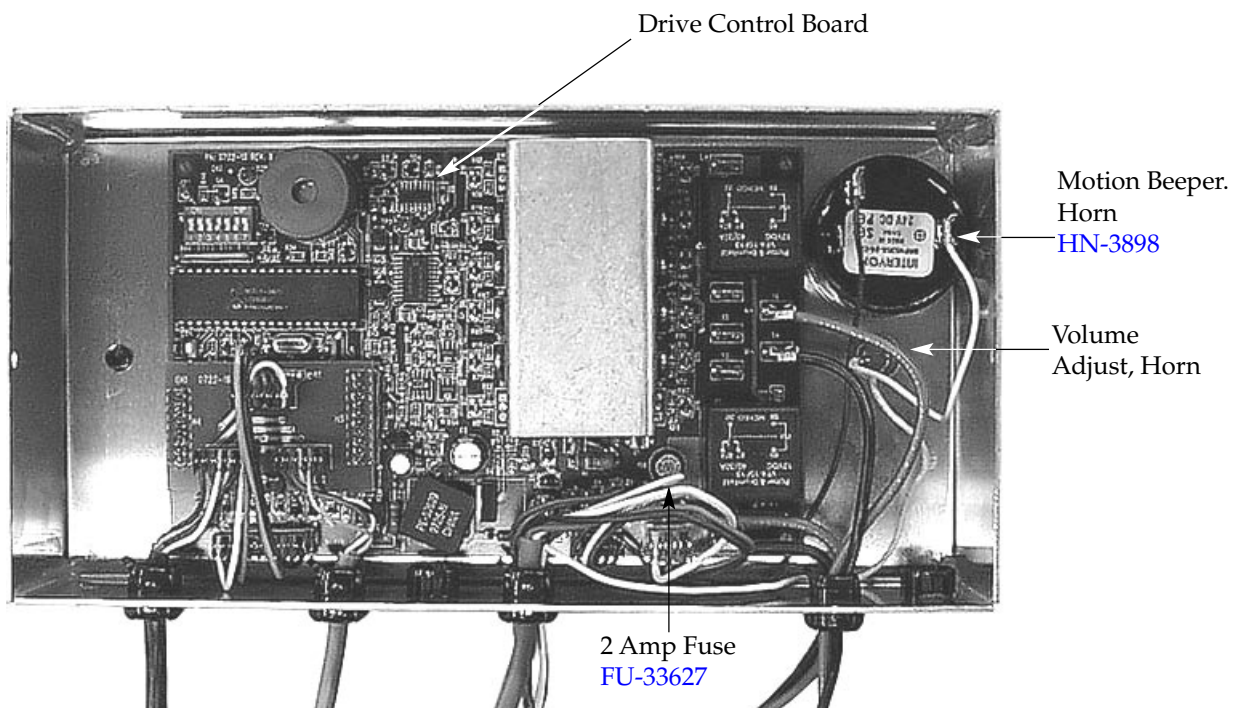

HOT/COLD FOOD DELIVERY SYSTEM

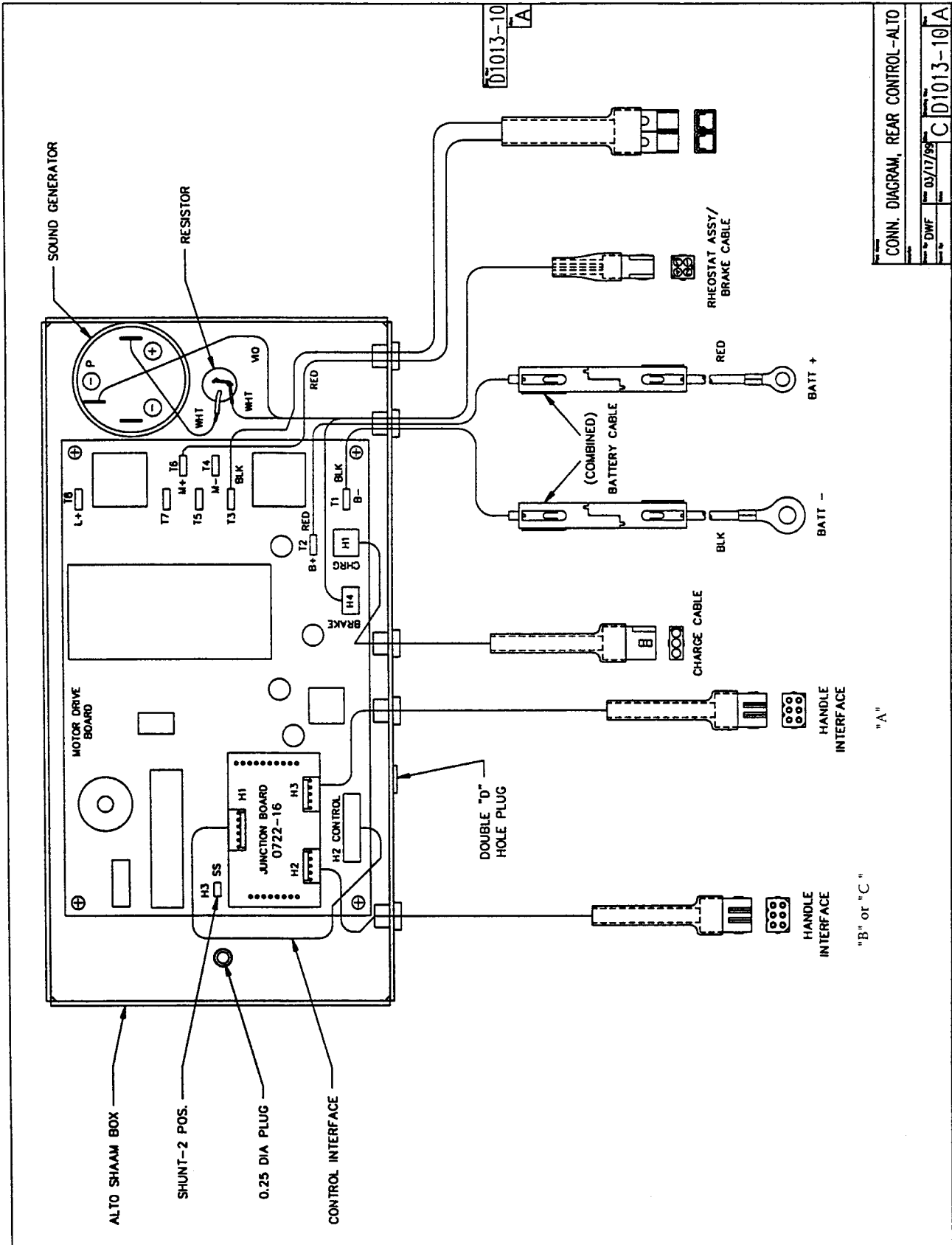

CONN. DIAGRAM, REAR CONTROL-ALTO
 DWG 03/17/95
 C D1013-10A

HOT/COLD FOOD DELIVERY SYSTEM

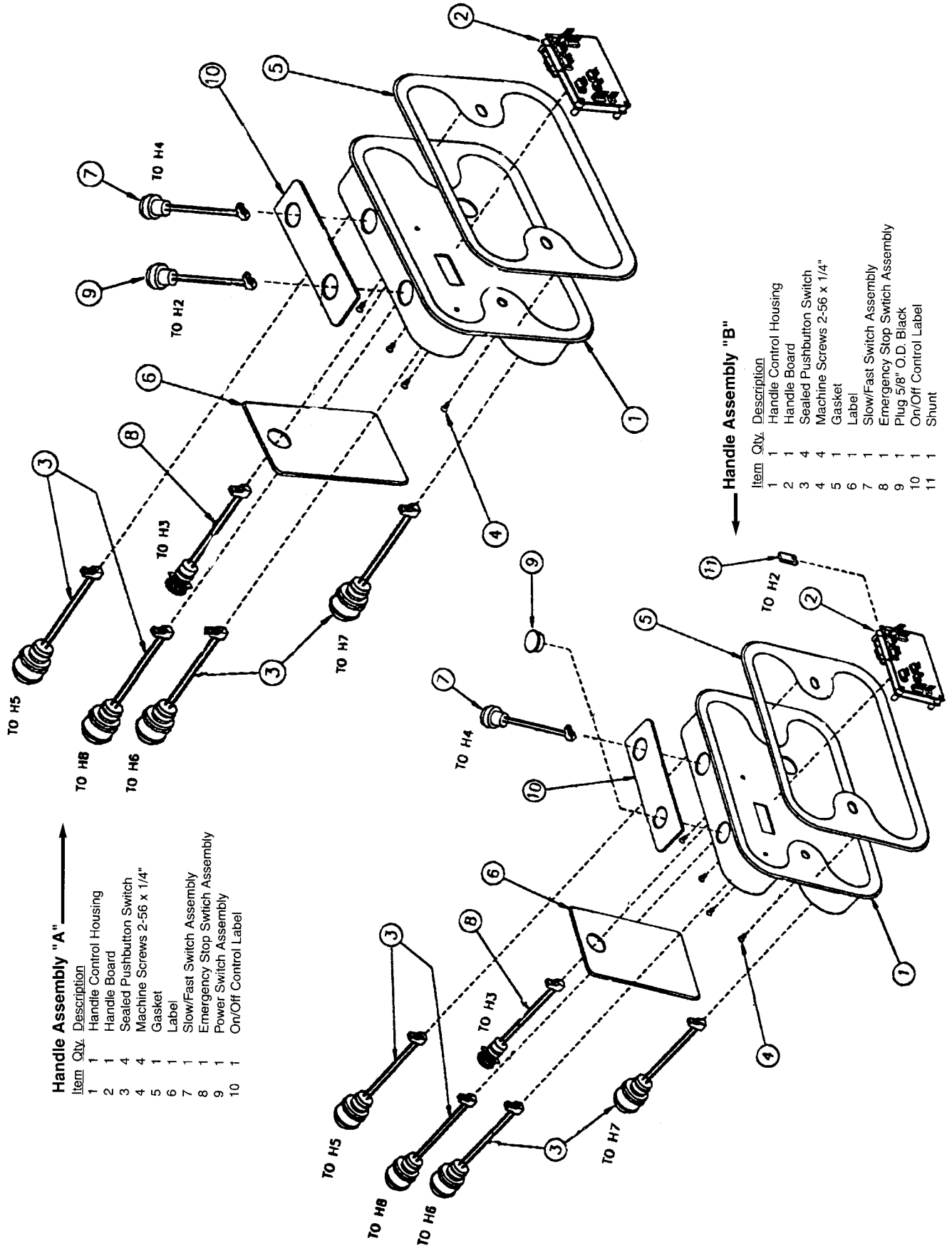

HOT/COLD FOOD DELIVERY SYSTEM

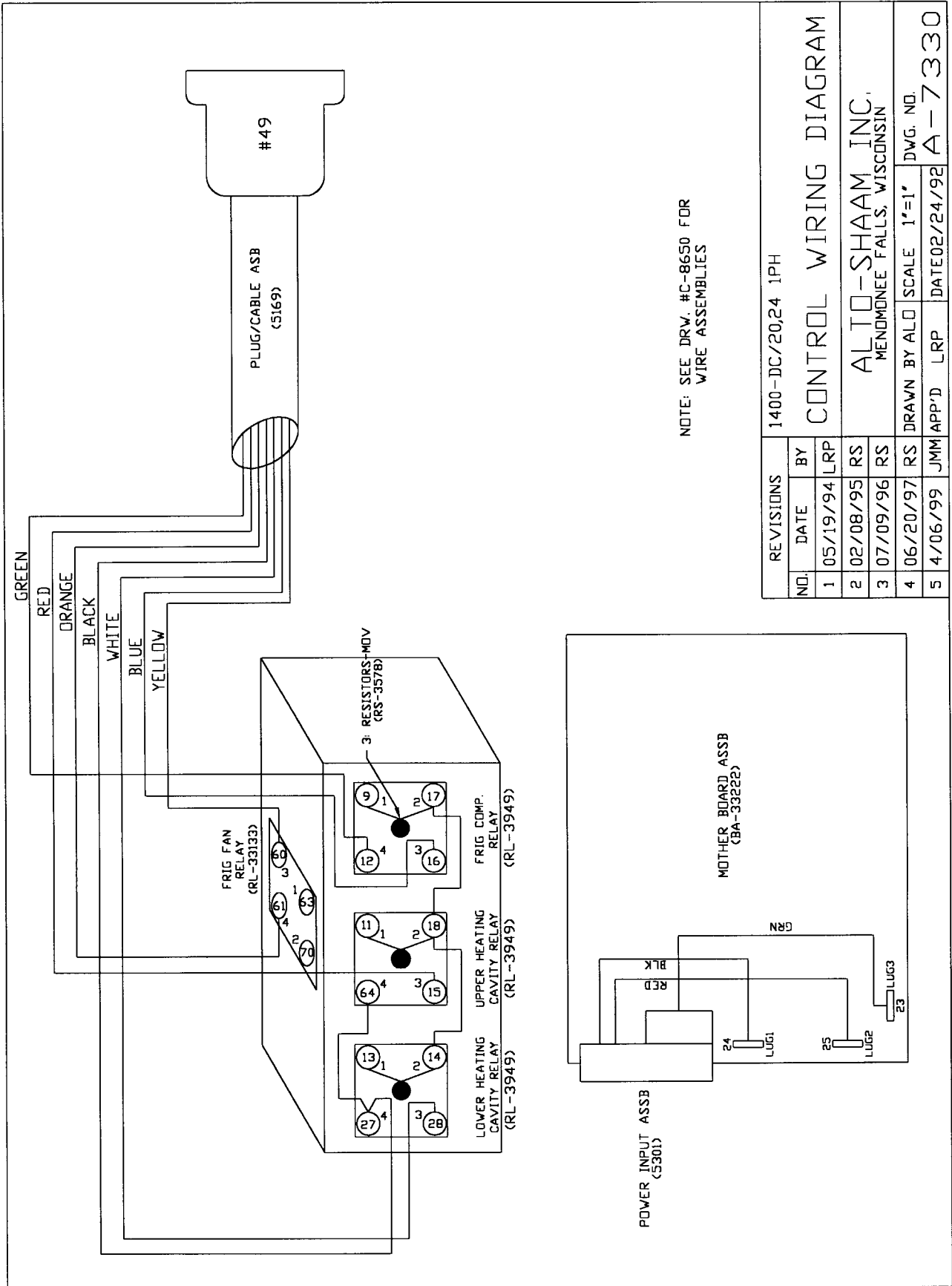

HOT/COLD FOOD DELIVERY SYSTEM

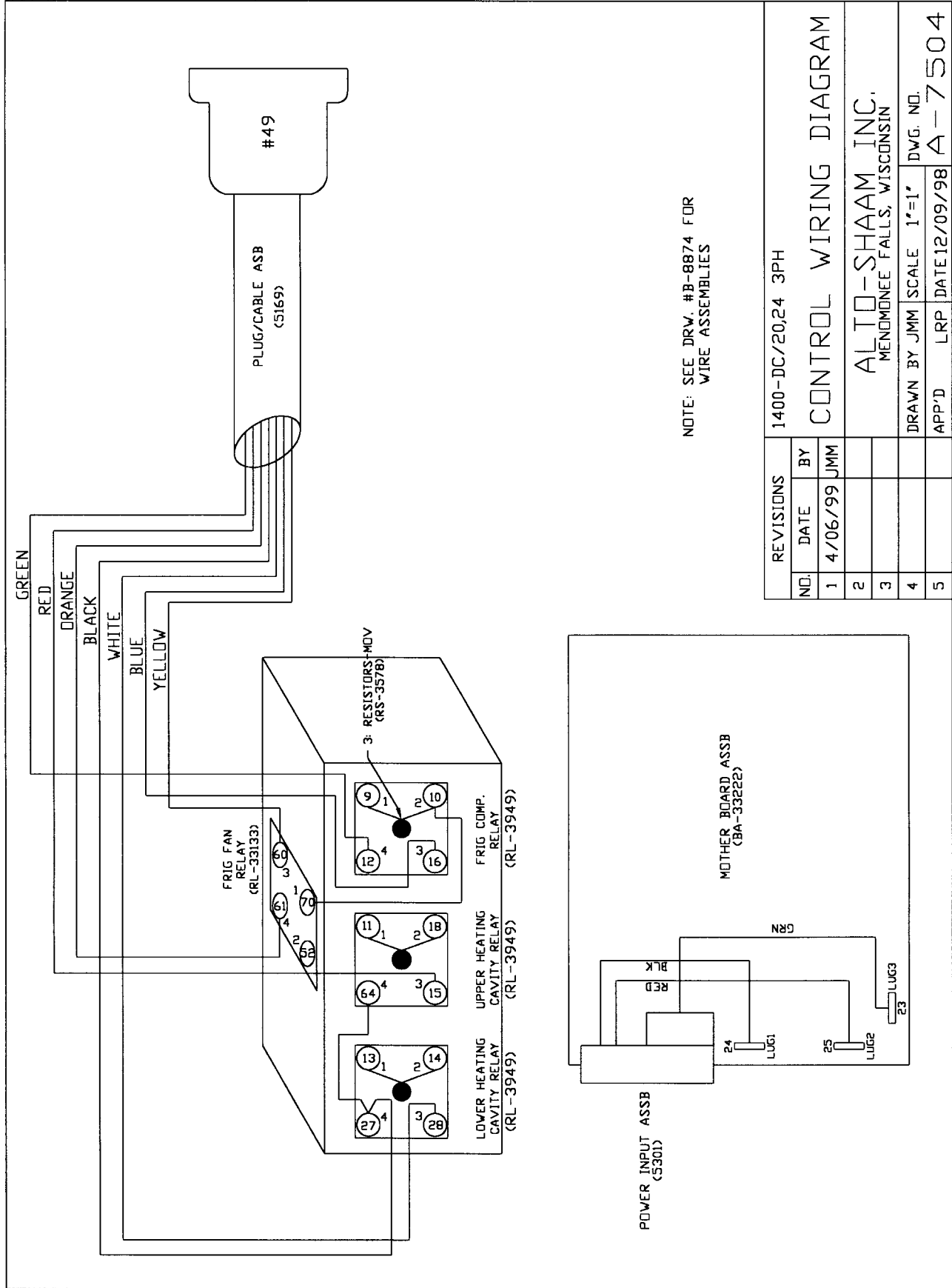

REVISIONS		1400-DC/20,24 3PH	
NO.	DATE	BY	
1	4/06/99	JMM	
2			
3			
4			
5			

CONTROL WIRING DIAGRAM

ALTO-SHAAM INC.
MENDONEE FALLS, WISCONSIN

DRAWN BY	JMM	SCALE	1"=1'	DWG. NO.	
APP'D	LRP	DATE	12/09/98		A-7504

HOT/COLD FOOD DELIVERY SYSTEM

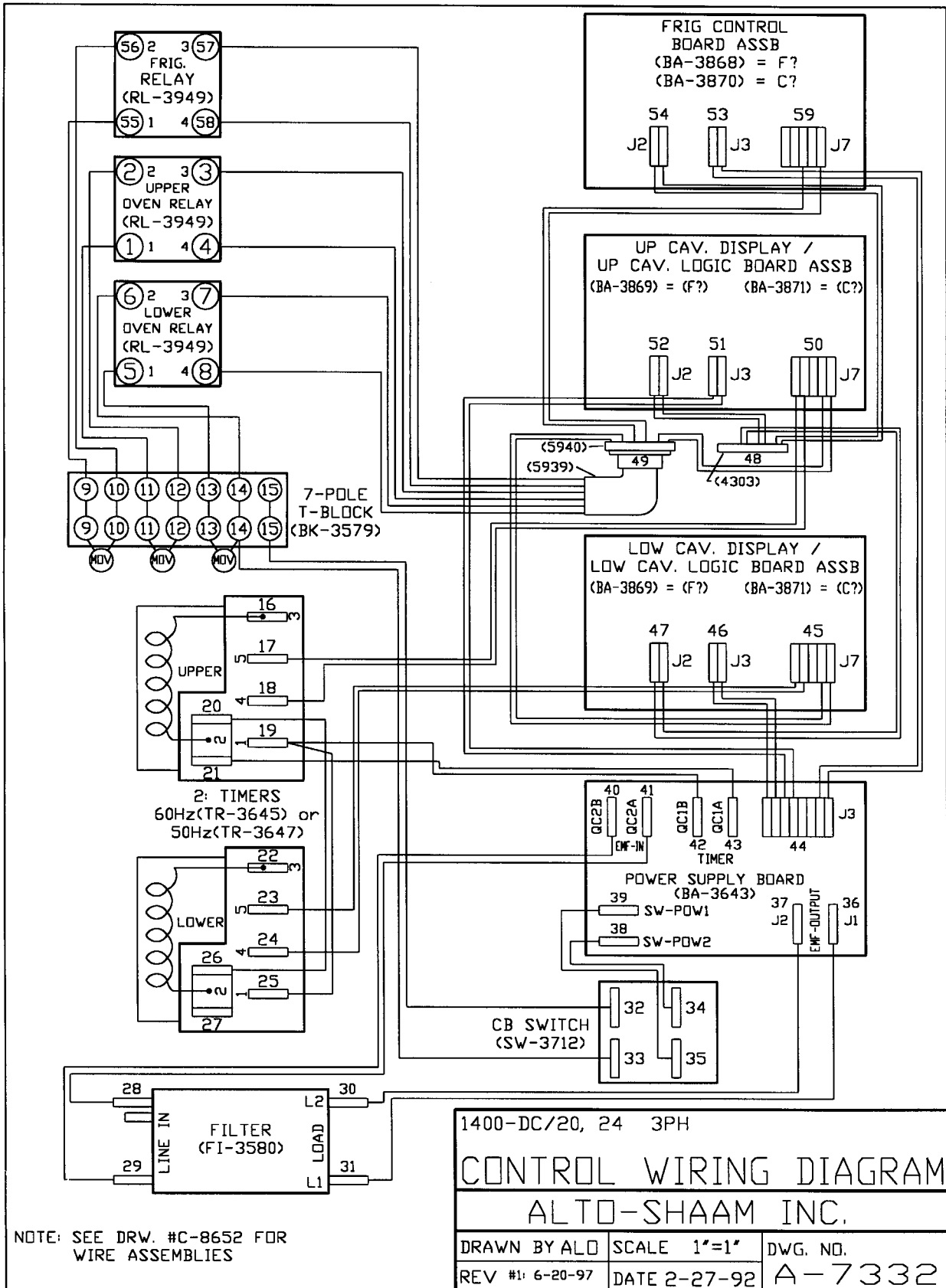

HOT/COLD FOOD DELIVERY SYSTEM

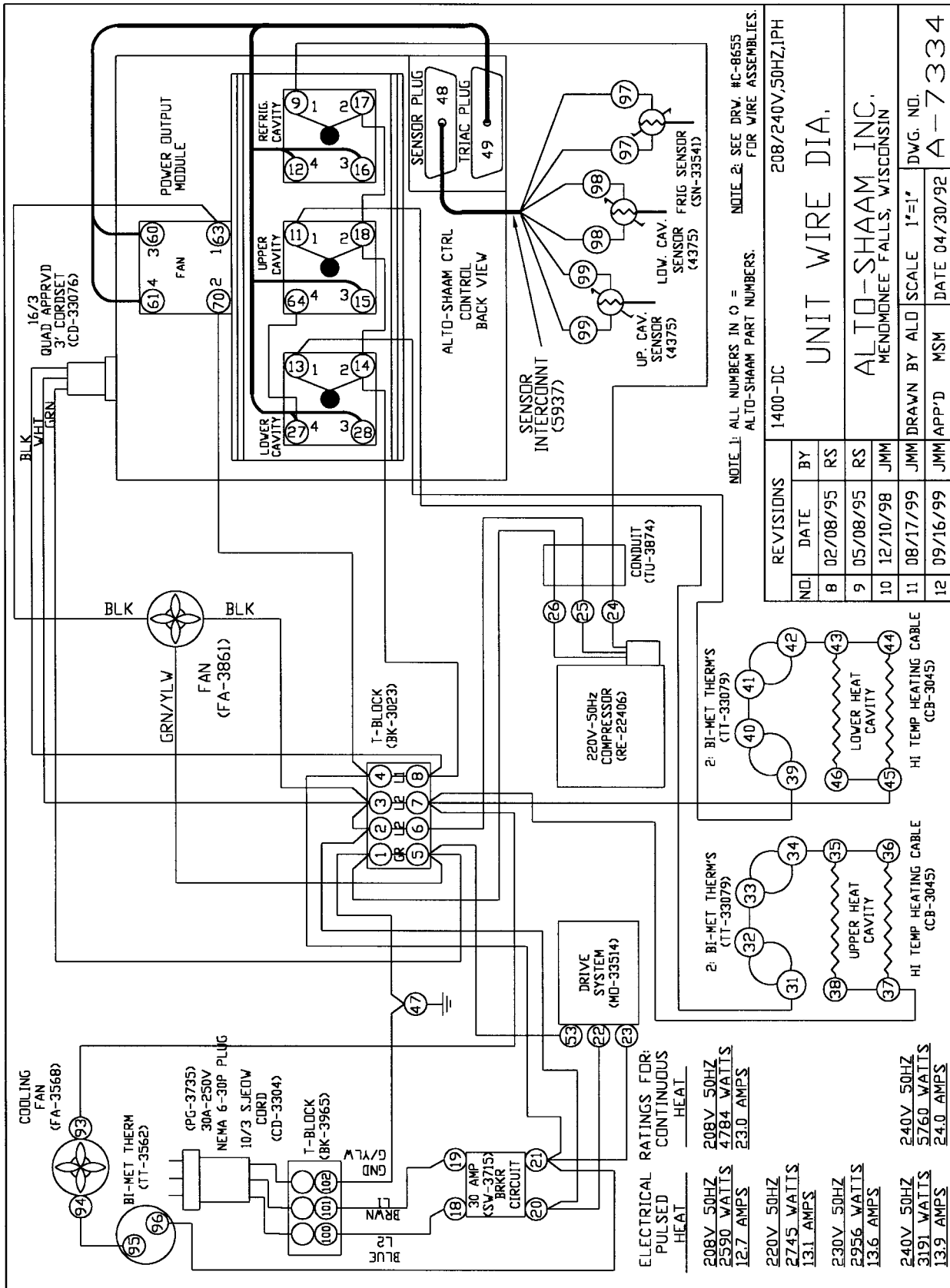

HOT/COLD FOOD DELIVERY SYSTEM

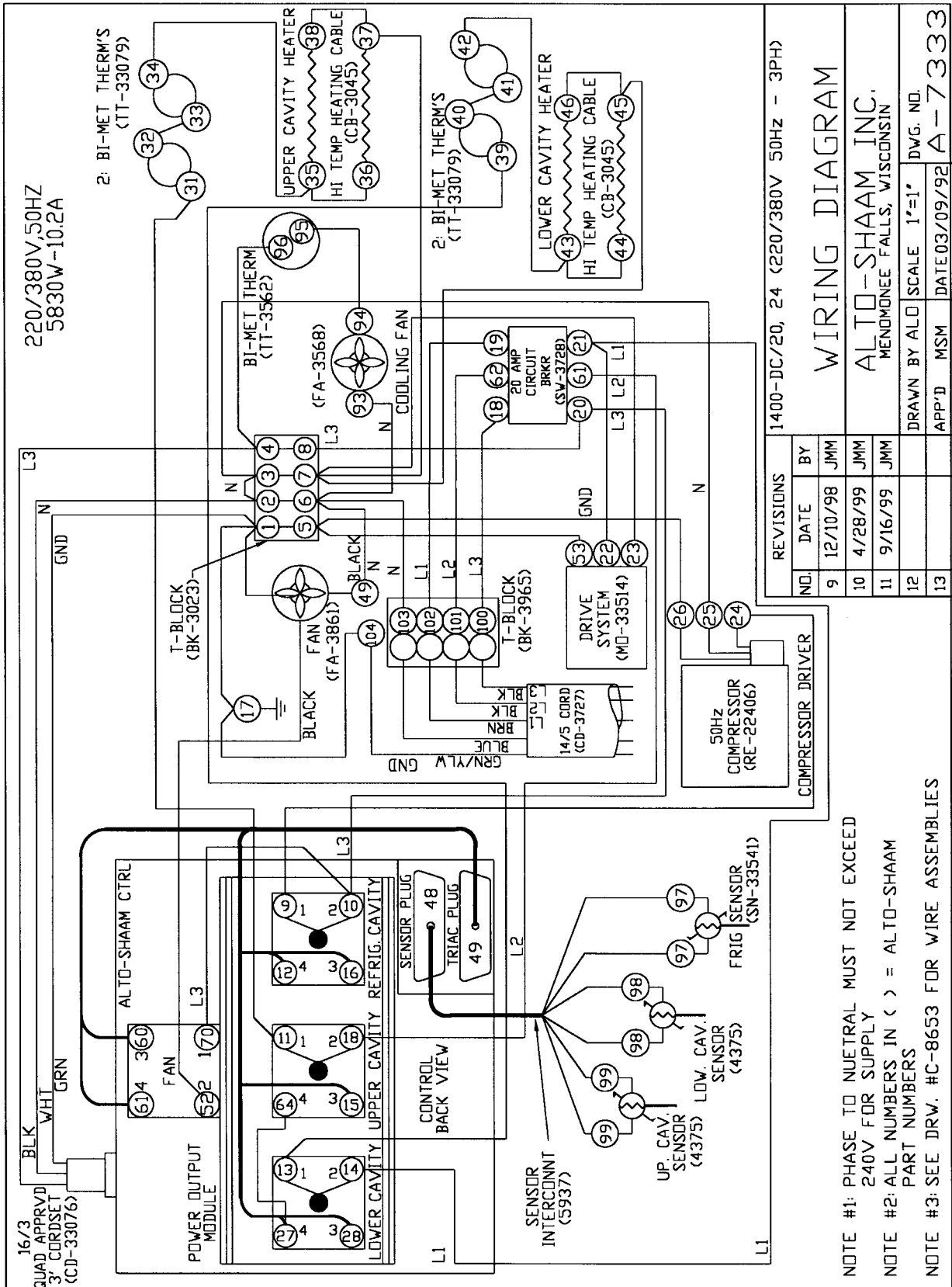

NOTE #1: PHASE TO NEUTRAL MUST NOT EXCEED 240V FOR SUPPLY

NOTE #2: ALL NUMBERS IN () = ALTO-SHAAM PART NUMBERS

NOTE #3: SEE DRW. #C-8653 FOR WIRE ASSEMBLIES

OPTIONAL TOW-BAR ASSEMBLY - 15079

MOUNTING INSTRUCTION

TOW-BAR

1. Remove the nut, lock washer, flat washer, and carriage bolt from each of the six positions surrounding the bumper assembly. Allow the bumper assembly to lower to the floor.
2. Position the TOW-BAR POST ASSEMBLY at the hot-compartment end of the cart, center, and insert the short end around the bumper assembly.
3. Position the TOW-BAR HITCH ASSEMBLY at the cold-compartment end of the cart, center, and insert around the bumper assembly.
4. Return the bumper assembly to the original position at the lower edge of the cart. Make certain the drive assembly wires remain in the correct slot position to avoid cutting or crimping the wires. When reassembled, the under-cart portions of the TOW-BAR ASSEMBLY should be centered between the caster brackets at each end of the cart.
5. Reattach the bumper assembly at each of the original six positions and fasten with the flat washer, lock washer, and nut as removed in step one.

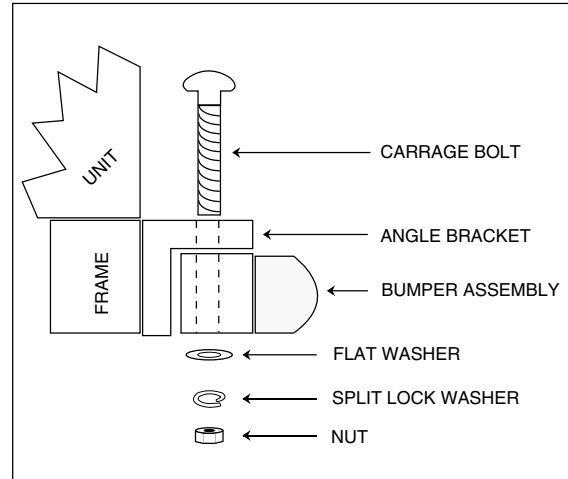

TOW-BAR CATCH

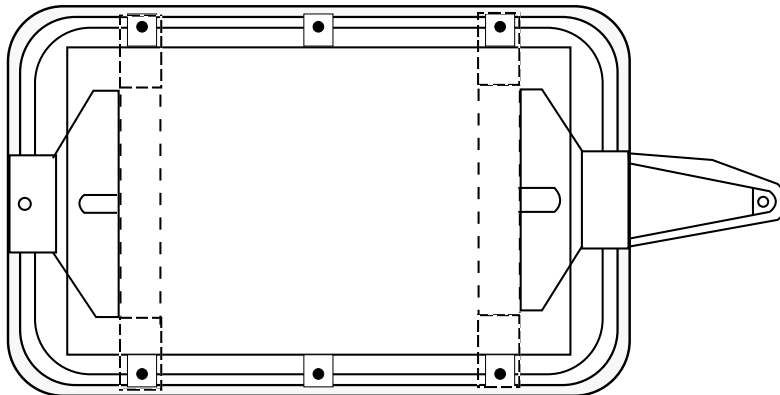

1. Lift the HITCH ASSEMBLY to an upright position along the unit exterior casing at the cold-compartment end of the cart.
2. With the TOW-BAR CATCH held in place, mark drilling holes on the exterior Food Delivery Cart casing. Drill and tap using #8-32 (4mm) screws.
3. Test for proper operation.

NOTE : For proper and safe operation when using the TOW-BAR, **ALWAYS** install the LYNCH PIN in the hole of the POST ASSEMBLY and make certain the Lynch Pin Ring surrounds the post.

ECCO2280-4/11/95

TRANSPORTATION DAMAGE and CLAIMS



All Alto-Shaam equipment is sold F.O.B. shipping point, and when accepted by the carrier, such shipments become the property of the consignee.

Should damage occur in shipment, it is a matter between the carrier and the consignee. In such cases, the carrier is assumed to be responsible for the safe delivery of the merchandise, unless negligence can be established on the part of the shipper.

1. Make an immediate inspection while the equipment is still in the truck or immediately after it is moved to the receiving area. Do not wait until after the material is moved to a storage area.
2. Do not sign a delivery receipt or a freight bill until you have made a proper count and inspection of all merchandise received.
3. Note all damage to packages directly on the carrier's delivery receipt.
4. Make certain the driver signs this receipt. If he refuses to sign, make a notation of this refusal on the receipt.
5. If the driver refuses to allow inspection, write the following on the delivery receipt:
Driver refuses to allow inspection of containers for visible damage.
6. Telephone the carrier's office immediately upon finding damage, and request an inspection. Mail a written confirmation of the time, date, and the person called.
7. Save any packages and packing material for further inspection by the carrier.
8. Promptly file a written claim with the carrier and attach *copies* of all supporting paperwork.

We will continue our policy of assisting our customers in collecting claims which have been properly filed and actively pursued. We cannot, however, file any damage claims for you, assume the responsibility of any claims, or accept deductions in payment for such claims.

ALTO-SHAAM® LIMITED WARRANTY

Alto-Shaam, Inc. warrants to the original purchaser that any original part that is found to be defective in material or workmanship will, at our option, subject to provisions hereinafter stated, be replaced with a new or rebuilt part.

The labor warranty remains in effect one (1) year from installation or fifteen (15) months from the shipping date, whichever occurs first.

The parts warranty remains in effect one (1) year from installation or fifteen (15) months from the shipping date, whichever occurs first.

Exceptions to the one year part warranty period are as listed:

- A. Halo Heat cook/hold ovens include a five (5) year parts warranty on the heating element. Labor will be covered under the terms of the standard warranty period of one (1) year or fifteen (15) months.
- B. Alto-Shaam Quickchillers include a five (5) year parts warranty on the refrigeration compressor. Labor will be covered under the terms of the standard warranty period of one (1) year or fifteen (15) months.

This warranty does not apply to:

1. Calibration
2. Replacement of light bulbs and/or the replacement of display case glass due to damage of any kind.
3. Equipment damage caused by accident, shipping, improper installation or alteration.
4. Equipment used under conditions of abuse, misuse, carelessness or abnormal conditions.
5. Any losses or damage resulting from malfunction, including loss of product or consequential or incidental damages of any kind.
6. Equipment modified in any manner from original model, substitution of parts other than factory authorized parts, removal of any parts including legs, or addition of any parts.

This warranty is exclusive and is in lieu of all other warranties, expressed or implied, including the implied warranties of merchantability and fitness for purpose. In no event shall the Company be liable for loss of use, loss of revenue, or loss of product or profit, or for indirect or consequential damages. This warranty is in lieu of all other warranties expressed or implied and Alto-Shaam, Inc. neither assumes or authorizes any persons to assume for it any other obligation or liability in connection with Alto-Shaam equipment.

ALTO-SHAAM, INC.

Warranty effective January 1, 2000

Record the model and serial numbers of the unit for easy reference.

Always refer to both model and serial numbers in your correspondence regarding the unit.

Model: _____
Serial Number: _____
Purchased From: _____
Date Installed: _____ Voltage: _____

HALO HEAT COOK/HOLD/SERVE SYSTEMS BY ALTO-SHAAM®

W164 N9221 Water Street • P.O. Box 450 • Menomonee Falls, Wisconsin 53052-0450 • U.S.A.

PHONE: 262.251.3800

FAX: 262.251.7067 • 800.329.8744 U.S.A./CANADA

WEBSITE:

800.558.8744 U.S.A./CANADA

262.251.1907 INTERNATIONAL

www.alto-shaam.com

HOT/COLD FOOD DELIVERY SYSTEM