

# TDS & TDD Series

## Service Guide

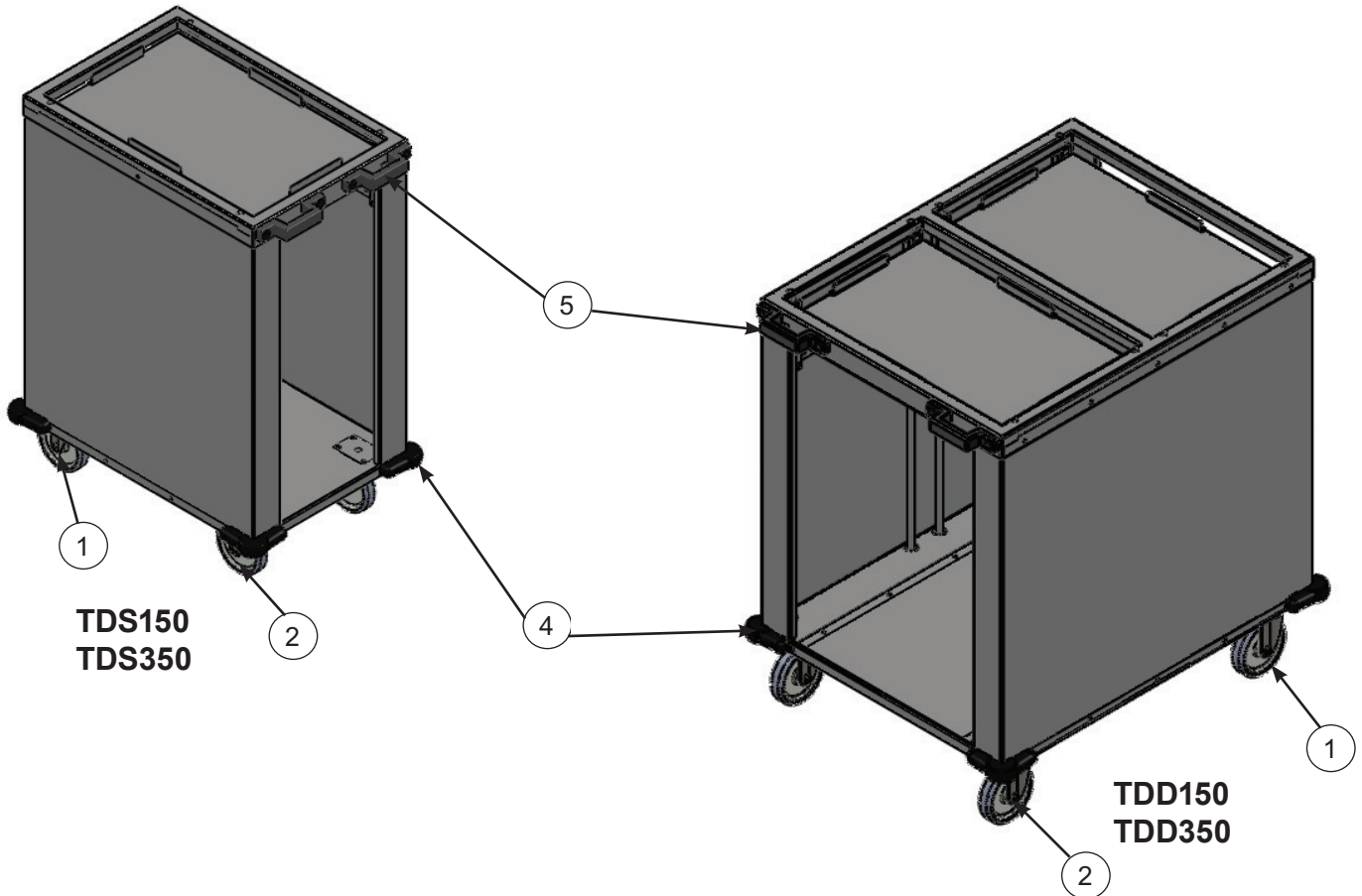

#	Qty	Part Number	Description
1	2	97223	5" swivel caster
2	2	92516	5" swivel with brake
3a*	12	12405	TDS350 spring
3b*	24	12405	TDD350 spring
3c*	15	12405	TDS150 spring
3d*	30	12405	TDD150 spring
4	4	93052	Corner bumper
5	2	99619	Handle rubber

\*Item not shown

## WARRANTY & LIABILITY

ALADDIN TEMP-RITE®  
EQUIPMENT  
LIMITED WARRANTY

Effective April, 2009

Aladdin Temp-Rite® (“ATR”) warrants to the original purchaser that the equipment listed below shall be free from defects in material and workmanship under normal use for the applicable warranty term set forth below. ATR’s obligation under this warranty is limited to the repair or replacement, at the sole option of ATR, of any part which upon inspection and examination by ATR or its authorized agent is found to be defective. A written description detailing the nature of the claimed defect, together with the equipment claimed to be defective if required by ATR, must be delivered to ATR or its authorized agent within 30 days of discovery of the claimed defect (but in no event later than 30 days after the expiration of the applicable warranty term).

EQUIPMENT	WARRANTY TERM	
	PARTS	LABOR
TDS350	1 year	90 Days
TDD350	1 year	90 Days
TDS150	1 year	90 Days
TDD150	1 year	90 Days

\*The warranty term commences 30 days after the date of ATR’s invoice for the equipment.

THE WARRANTIES AND REPRESENTATIONS OF ATR CONTAINED HEREIN ARE EXPRESSLY IN LIEU OF, AND THE BUYER WAIVES, ANY AND ALL OTHER WARRANTIES EXPRESS OR IMPLIED, INCLUDING THE WARRANTIES OF MERCHANTABILITY AND FITNESS FOR A PARTICULAR PURPOSE, AND ANY OTHER REMEDIES AGAINST ATR, WHETHER BASED UPON CONTRACT, NEGLIGENCE, STRICT LIABILITY OR OTHERWISE. ATR SHALL NOT BE LIABLE FOR ANY CONSEQUENTIAL OR INCIDENTAL DAMAGES OR ECONOMIC LOSS OF ANY NATURE (INCLUDING WITHOUT LIMITATION LOSS OF REVENUES AND/OR PROFITS) THAT MAY BE CLAIMED TO RESULT FROM ANY NEGLIGENCE OR BREACH OF WARRANTY OR CONTRACT BY ATR.

### Exceptions and Exclusions

This warranty is issued only to the original purchaser, and is not transferable and applies only to the products installed within the United States of America, its territories and Canada. During the term of any labor warranty, ATR will pay all pre-approved shipping charges incurred in returning defective equipment to ATR and labor costs incurred in the removal and reinstallation of such equipment. Contact ATR before returning any defective equipment or otherwise performing any warranty repairs. ATR assumes no liability for any work or repair performed without its prior approval. After the expiration of any labor warranty, the original purchaser is responsible for all shipping charges incurred in returning defective equipment to ATR and labor for removing and reinstalling such equipment. ATR shall not be responsible for the replacement of expendable items like lamps and fuses or product failure resulting from normal wear and tear, improper installation, misuse, sabotage, abuse, neglect, accident, unauthorized alterations to repair, or other factors beyond the control of ATR. Neither this warranty, nor the liability of ATR may be modified or extended by action of any agent, distributor or other person or by custom or practice.

CALL ATR TOLL FREE AT 1-800-888-5426 IF YOU HAVE ANY QUESTIONS ABOUT THIS WARRANTY OR YOUR ATR PRODUCT.