

**Aladdin Temp-Rite**<sup>®</sup>...better by degrees.

P.O. Box 2978, Hendersonville, TN 37077-2978  
1-800-888-8018 or 615-537-3600  
Fax 1-888-812-9956  
www.aladdintemp-rite.com



# ROOM SERVICE CART RS7x/RS10x SERIES RSPT20/RSPT21 SERIES



Model RSPT20



Model RS10

---

---

INSTALLATION, OPERATION & MAINTENANCE MANUAL

---

---

Manual P/N 97072  
Rev. O 10/22/2015

Copyright © October 2004 Aladdin Temp-Rite®

Changes may be made to the information in this document without notification.

---

---

# ROOM SERVICE CARTS

---

---

## CONTENTS

---

- I. MODELS 4
- II. RECEIVING INSPECTIONS 5
- III. INSTALLATION 5
- IV. OPERATING INSTRUCTIONS 5
- V. CLEANING 6
- VI. MAINTENANCE 6
- VII. TROUBLESHOOTING 7
- VIII. SERVICE 7
- IX. DRAWINGS/PARTS LIST 8
- X. WARRANTY 10

# ROOM SERVICE CARTS

## I. MODELS

### ALADDIN TEMP-RITE

Aladdin Temp-Rite's® Room Service Carts are the perfect addition to today's demanding custom meal delivery service. The versatile RS7 and RS10 carts are designed to accommodate a single tray per shelf, end-loaded. The RSPT20 and RSPT21 are designed to accommodate 12 trays per cart, 2 trays per shelf, side-loaded with two door "pass through" design to allow for easy loading and removal of trays during meal assembly or delivery on patient floors. Carts are constructed of durable, sanitary stainless steel to provide years of trouble-free service. The compact size and easy mobility make room service meal delivery quicker and more efficient.

#### STANDARD FEATURES:

- Two door “pass through” design for easy loading and removal of trays (RSPT20, RSPT21 only)
- Continuous Door Hinge for added strength and stability
- Magnetic door hold open device located on base of cart to hold door in open position during tray delivery
- Rubber coated vertical push/pull handles (2) rear mounted with reinforcing internal SS plate (RS7, RS10 only)
- Black corner bumpers attached to base of cart and extend past push/pull handles
- Casters: (RS7, RS10) Standard with four 5 inch polyurethane tread, two fixed, two swivel (RSPT20, RSPT21) Standard with four 6 inch polyurethane tread, two fixed, two swivel, with brakes
- Stainless steel gravity latch is easy to use and hold door securely during transport (RS)
- Two magnetic catches hold doors tightly against cart tank reducing noise from vibration during transport (RSPT only)
- NSF listed
- Model # RSPT20, RSPT21: 3-sided top rail
- Removable tray slides for easy cleaning

#### SPECIFICATIONS RS7, RS10:

- 14 gauge Stainless Steel Base extends in rear of cart past push handles
- 18 gauge Stainless Steel Body
- 16 gauge Stainless Steel Door overlapping top front of cart
- 18 gauge contour formed tray slides

#### SPECIFICATIONS RSPT20, RSPT21:

- 14 gauge Stainless Steel Base
- 18 gauge Stainless Steel Body
- 16 gauge Stainless Steel Top
- 16 gauge Stainless Steel Door overlapping top front and rear of cart
- 18 gauge contour formed Stainless Steel tray slides

|               | End Loaded  |                            | Side Loaded                 |                             |
|---------------|---|----------------------------|-----------------------------|-----------------------------|
|               | 15" x 20" cafeteria tray or 15.5" x 21.5" Room Service Style Tray |                            | (Standard Cafeteria Tray)   | (Room Service Style Tray)   |
| Model #       | RS7x  | RS10x                      | RSPT20                      | RSPT21                      |
| Tray Capacity | 7   | 10                         | 12 (15" x 20")              | 12 (15.5" x 21.5")          |
| Dimensions    | H 54" x W 26" x D 25-9/16"  | H 62" x W 26" x D 25-9/16" | H 46.2" x W 30.5" x D 36.9" | H 46.2" x W 30.5" x D 36.9" |
| Weight        | 125 lbs   | 141 lbs                    | 158 lbs                     | 158 lbs                     |

---

---

## II. RECEIVING INSPECTIONS

---

You should carefully inspect your Room Service cart to assure that no damage has occurred in transit. If however, damage is detected see the following damaged goods policy. Under no condition may a damaged unit be returned to Aladdin Temp-Rite without first obtaining written permission (return authorization). No credit will be issued for claims not reported to Aladdin within ten (10) business days from receipt of shipment.

### ALADDIN DAMAGED GOODS POLICY

There are two types of damaged merchandise:

- Visual Damage
- Concealed Damage

Visual Damage – When the product being received is visibly damaged.

1. Receiver should not accept merchandise with visual damage.
2. Receiver must sign delivery receipt “refused merchandise due to damage” and specify damage.
3. Receiver should call Aladdin Customer Service immediately after refusal.
4. Carrier will notify Aladdin Traffic Department and a claim will be filed.
5. Carrier will send acknowledgement of claim within 7 days after receiving.

Concealed Damage – When damaged merchandise cannot be externally detected.

Any receiving operation should be looking for this type of damage. Sometimes, however, depending on the type of product, it is almost impossible to notice.

1. Merchandise must not be removed from point of delivery and all packaging must be kept intact.
2. Receiver must contact Aladdin customer service to report damage.
3. Aladdin traffic department will request inspection based on the dollar value of the cargo.
4. Aladdin traffic department will file a claim based on the findings of the inspection.

Failure to comply with these policies will result in the customer’s responsibility to file claims.

## III. INSTALLATION

---

- A. After removing the outside carton remove all packing and strapping material from the exterior and interior of the unit.
- B. Remove paper covering from unit.
- C. Remove the unit from the sectioned cardboard box. This is done by tilting the unit and rolling it off the box.

## IV. OPERATING INSTRUCTIONS

---

- A. For best results, insert loaded trays into the cart as quickly as possible. Doors should be opened only when necessary in order to help keep foods at the proper temperature and prevent contamination of foods from, outside sources.
- B. Avoid bumping carts into doors, walls or obstructions of any kind.
- C. Never move cart unless all doors are securely closed. Serious damage to hinges and doors may result if bumped into walls or other equipment when doors are open.

---

---

# ROOM SERVICE CARTS

---

---

## V. CLEANING

---



### CAUTION

Harsh chemicals and insufficiently diluted sanitizers will damage stainless steel surface. Never use cleaning agents that contain phosphates or chlorides. These chemicals will cause permanent damage to the stainless steel finish, and void equipment warranty.

The Aladdin room service carts should be sanitized and cleaned after each use using the following method

1. Tray slide assemblies are easily removed, without tools, for cleaning; simply lift up the slide to release from attachment pins and pull off pins. The assemblies can now be pulled out the door opening. The assemblies should be hand washed.
2. Wipe walls, handles, and sides with a soft clean cloth, using warm water and a mild detergent. (It is recommend that you wipe with the grain of the surface to avoid scratches.)
3. Use a soft nylon brush on any food buildup and in corners.
4. Sanitize with a properly diluted sanitizer (according to manufacturers recommendations).
5. Dry thoroughly with a dry cloth to remove moisture.
6. Never use sharp objects, abrasives or scrapers.
7. Do not wash cart in a pressurized wash system.

## VI. MAINTENANCE

---

### LATCHES

1. Lubricate latches regularly with WD-40, silicone spray, graphite or other commercial lubricants for stainless steel products. **DO NOT** use oil.

---

---

## VII. TROUBLESHOOTING

---

Performance problems often result from minor incidents that can be found and corrected by checking and following the basic points mentioned in the table below.

| SYMPTOM                                     | PROBABLE CAUSE   | CORRECTION  |
|---|--|---|
| Cart hard to push/pull.                     | Debris in caster.                                      | Remove debris.  |
| Difficulty in opening/closing doors.        | Hinges require lubrication.                            | Lubricate hinges.   |
| Trays do not slide easily into cart.        | Tray slides dirty.<br>Tray slides not seated properly. | Remove slides and clean.<br>Correct alignment of tray slides. |
| Latch "sticky" - does not operate smoothly. | Residue buildup.                                       | Clean and lubricate latch.                                    |

## VIII. SERVICE

---

If you need assistance, call the Aladdin Temp-Rite® Toll Free Service Line, call: 1-800-888-5426

# ROOM SERVICE CARTS

## IX. DRAWINGS/PARTS LIST

### RS7 & RS10 SERIES MODELS

| No. | PN    | Description               |
|-----|-------|---------------------------|
| 1   | 97223 | Caster, 5, Swivel, RS7/10 |
| 2   | 97228 | Caster, 5, Rigid, RS7/10  |
| 3   | 97227 | Handle, Push, RS7/10      |
| 4a  | 11495 | Door, Handle,SS           |
| 4b* | 97225 | Door, Latch, Knob, RS7/10 |
| 5a* | 10637 | Bolt 8/32 x 1" SS         |
| 5b* | 10635 | Magnet Square Neodymium   |
| 5c* | 10636 | Spacer Nylon              |
| 5d* | 96689 | Cap Nut 8-32 Locking SS   |

| No. | PN    | Description                                    |
|-----|-------|--|
| 5*  | 99939 | Magnetic Catch Al ( <i>before April 2011</i> ) |
| 6   | 97222 | Plate, Strike, RS7/10                          |
| 7   | 97224 | Bumper, Door, RS7/10                           |
| 8   | 93052 | Bumper, Corner, RS7/10                         |
| 9*  | 97579 | Optional Caster, 6, Rigid                      |
| 10* | 98195 | Optional Caster, 6, swivel                     |
| 11* | 98568 | Tray guide RS7 Right hand                      |
| 12* | 98570 | Tray guide RS7 Left hand                       |
| 13* | 98569 | Tray guide RS10 Right hand                     |
| 14* | 98567 | Tray guide RS10 Left hand                      |
| 15* | 99535 | Latch, Gravity                                 |
| 16* | 99111 | Magnet, Asy, Door, latch                       |
| 17* | 99112 | Plate, Door, latch                             |

\* Items not shown  
 \* For carts after SN: RS75D11204  
 \* RS7 for Carts before SN: RS75A13331  
 RS10 for Cart before SN: R105D13478

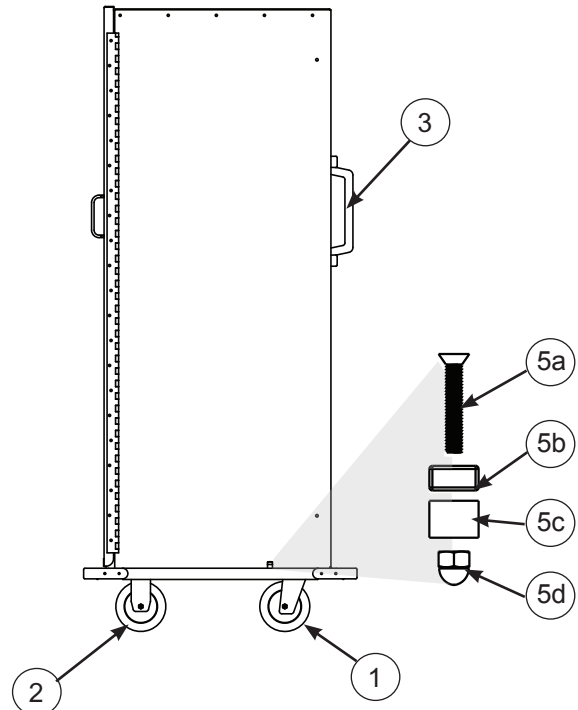
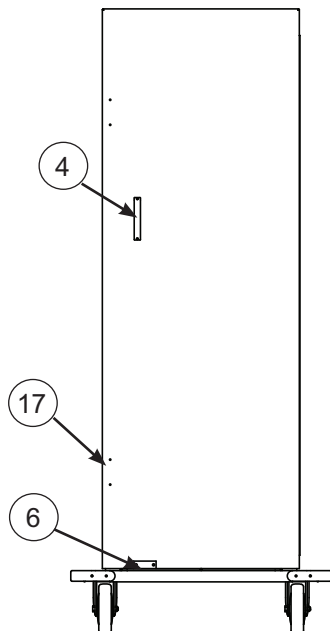
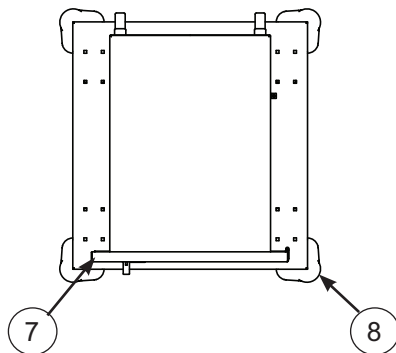

## RSPT20 & RSPT21 SERIES MODELS

| No. | Aladdin p/n | Description                  |
|-----|-------------|------------------------------|
| 1   | 97581       | Caster, 6" Swivel, RSPT20/21 |
| 2   | 97579       | Caster, 6", Rigid, RSPT20/21 |
| 3a  | 11495       | Door, Handle, SS             |
| 3b* | 97225       | Door, Latch, Knob RSPT20/21  |
| 4   | 97222       | Plate, Strike, RSPT20/21     |
| 5a* | 10637       | Bolt 8/32 x 1" SS            |
| 5b* | 10635       | Magnet Square Neodymium      |
| 5c* | 10636       | Spacer Nylon                 |
| 5d* | 96689       | Cap Nut 8-32 Locking SS      |
| 5*  | 99939       | Magnetic Catch Al            |
| 6   | 97224       | Bumper, Door, RSPT20/21      |
| 7   | 93052       | Bumper, Corner, RSPT20/21    |
| 8a* | 97578       | 15" x 20" Tray Slides        |

| No.   | Aladdin p/n | Description   |
|-------|-------------|---|
| 8b*   | 99418       | 15" x 20" Tray Slides, for units after Nov. 2008    |
| 9a*   | 97580       | 15.5" x 21.5" Tray Slides                           |
| 9b*   | 99419       | 15.5" x 21.5" Tray Slides for units after Nov. 2008 |
| 10*   | 99535       | Latch, Gravity                                      |
| 11*   | 99111       | Magnet, Asy, Door, Catch                            |
| 12*   | 99112       | Plate, Door, Catch                                  |
| 13 ♣  | 10612       | Top rail  |
| 14 ♣* | 11710       | Top rail 1/4-20 X 5/8" carriage bolt                |
| 15 ♣* | 39260       | Top rail 1/4-20 Acorn nut                           |
| 16 ♣  | 99115       | Top rail end plug                                   |

\* Items not shown

♦ For carts after SN RSPT20G12339

♣ For carts before SN RSPT20F12340

♣ For casts after SN RSPT20K15671

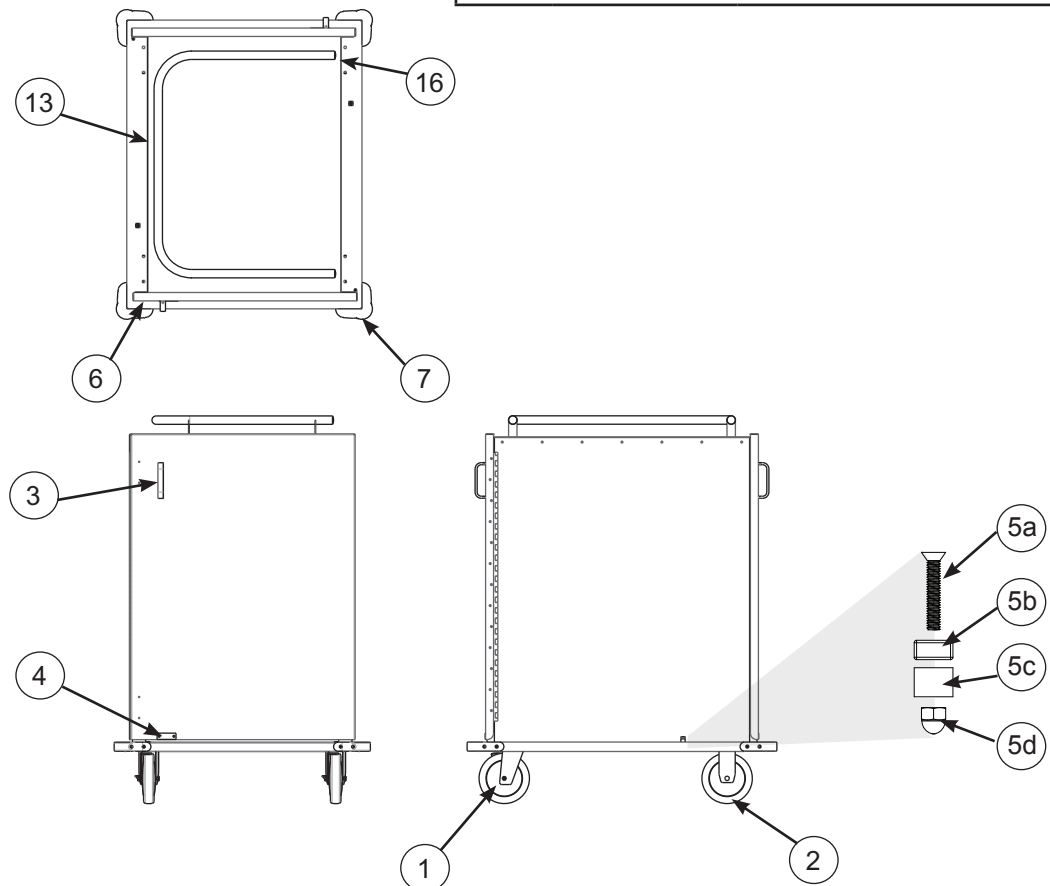

---

---

# ROOM SERVICE CARTS

---

---

## X. WARRANTY

---

ALADDIN TEMP-RITE  
EQUIPMENT  
LIMITED WARRANTY

Effective June 1, 2003

\*\*The warranty term commences 30 days after Aladdin Temp-Rite's invoice for the equipment.

Aladdin Temp-Rite ("ATR") warrants to the original purchaser that the equipment listed below shall be free from defects in material and workmanship under normal use for the applicable warranty term set forth below. ATR's obligation under this warranty is limited to the repair or replacement, at the sole option of ATR, of any part which upon inspection and examination by ATR or its authorized agent is found to be defective. A written description detailing the nature of the claimed defect, together with the equipment claimed to be defective if required by ATR, must be delivered to ATR or its authorized agent within 30 days of discovery of the claimed defect (but in no event later than 30 days after the expiration of the applicable warranty term).

| EQUIPMENT                                | WARRANTY TERM** |              |
|--|-----------------|--------------|
|  | PARTS           | LABOR        |
| RS75, RS76, RS105, RS106, RSPT20, RSPT21 | ONE (1) YEAR    | ONE (1) YEAR |

\* Reflects Caster size

\*\*The warranty term commences 30 days after ATR's invoice for the equipment.

THE WARRANTIES AND REPRESENTATIONS OF ATR CONTAINED HEREIN ARE EXPRESSLY IN LIEU OF, AND THE BUYER WAIVES, ANY AND ALL OTHER WARRANTIES EXPRESS OR IMPLIED, INCLUDING THE WARRANTIES OF MERCHANTABILITY AND FITNESS FOR A PARTICULAR PURPOSE, AND ANY OTHER REMEDIES AGAINST ATR, WHETHER BASED UPON CONTRACT, NEGLIGENCE, STRICT LIABILITY OR OTHERWISE. ATR SHALL NOT BE LIABLE FOR ANY CONSEQUENTIAL OR INCIDENTAL DAMAGES OR ECONOMIC LOSS OF ANY NATURE (INCLUDING WITHOUT LIMITATION LOSS OF REVENUES AND/OR PROFITS) THAT MAY BE CLAIMED TO RESULT FROM ANY NEGLIGENCE OR BREACH OF WARRANTY OR CONTRACT BY ATR.

### Exceptions and Exclusions

This warranty is issued only to the original purchaser, and is not transferable and applies only to the products installed within the United States of America, its territories and Canada. During the term of any labor warranty, ATR will pay all pre-approved shipping charges incurred in returning defective equipment to ATR and labor costs incurred in the removal and reinstallation of such equipment. Contact ATR before returning any claimed defective equipment or otherwise performing warranty repairs. ATR assumes no liability for any work or repair performed without its prior approval. After the expiration of any labor warranty, the original purchaser is responsible for all shipping charges incurred in returning defective equipment to ATR and labor for removing and reinstalling such equipment. ATR shall not be responsible for the replacement of expendable items like lamps and fuses or product failure resulting from normal wear and tear, improper installation, misuse, sabotage, abuse, neglect, accident, unauthorized alterations or repair, or other factors beyond the control of ATR. Neither this warranty nor the liability of ATR may be modified or extended by action of any agent, distributor or other person or by custom or practice.





250 East Main Street, Hendersonville, TN 37075

1-800-888-8018 • [www.aladdintemprite.com](http://www.aladdintemprite.com) • [info@aladdin-atr.com](mailto:info@aladdin-atr.com)