

Aladdin Temp-Rite®

Installation, Operation, and Maintenance Manual

For models beginning with Serial No. A1000 and above

Pellet System Delivery Carts MDSL & MDEL Series



MDSL



MDEL

Aladdin Temp-Rite®
P.O. Box 2978
Hendersonville, TN 37077-2978
Tel: 1 (800) 888-8018
Fax: 1 (615) 537-3642

Manual P/N 97257
October 6, 2005 Revision E

Form 113798

Complete the information below so it will be available for quick reference.

Model Number _____ Serial Number _____

Service Agency _____ Phone _____

Parts Source _____ Phone _____

Date Installed _____

Aladdin Temp-Rite® Tech Services:

Aladdin Temp-Rite®
P.O. Box 2978
Hendersonville, TN 37077-2978
Tel: 1 (800) 888-5426
Fax: 1 (888) 812-9956
info@aladdin-atr.com

In Canada Call: 1 (800) 465-1563 - Fax: (905) 564-1434

NOTE: When calling to order parts, be sure to have the model number and serial number of your Pellet Cart.

COPYRIGHT © 2005 by Aladdin Temp-Rite, All Rights Reserved

PELLET SYSTEM DELIVERY CARTS

Installation, Operation and Maintenance Manual

CONTENTS

	Page
MODELS	2
OPTIONS AND ACCESSORIES	3
RECEIVING INSPECTIONS	4
INSTALLATION	4
OPERATION	5
CLEANING	5
MAINTENANCE	6
TROUBLESHOOTING	7
REPLACEMENT PARTS	8
LIMITED WARRANTY	10
REVISION HISTORY	11

MODELS

MD__SLA : Side load with aluminum base
 MD__SLS: Side load with stainless steel base

MD__ELA : End load with aluminum base
 MD__ELS: End load with stainless steel base

Aladdin's versatile Pellet System Delivery Carts are available in a variety of capacities to conform to your delivery needs. These carts ensure efficient, quiet transportation for your Pellet System Trays. The MD__SL models are designed to accommodate 2 trays per shelf, side loaded. The MD__EL models are designed to accommodate a single tray per shelf end loaded. Constructed of durable, sanitary stainless steel to provide years of trouble free meal delivery service.

The cabinet is constructed with 18 gauge stainless steel with vents on both sides. There are two 12 gauge stainless steel reinforcement channels on single door models (four channels on double and triple door models). The channels are located on the underside of the top panel and extend fully from side to side. The pins that the tray slide assemblies attach to are connected to these reinforcement channels. On the underside of the cabinet body there are two 12 gauge stainless steel reinforcement channels that run side to side, the casters are bolted to these channels. Bases are available in aluminum or stainless steel. There are also small channels on the underside that contain the drains, one drain/channel on single door, two on double and three on triple door models. Doors are fully insulated double sided pocket doors constructed of 20 gauge stainless steel. A one inch diameter stainless steel push handle is mounted to cart back on single door models and to end of cart top on double and triple door models.

MD__SL:
 Side Load Series

Model No.	Tray capacity 4-1/2" spacing	No. of Doors	Dimensions (inches)			Weight (lbs)	
			L	W	H	Net	Ship
MD10SLA	10	1	38-1/2	29-5/16	40-1/2	174	214
MD10SLS	10	1	38-1/2	29-5/16	40-1/2	182	222
MD16SLA	16	1	38-1/2	29-5/16	47	185	225
MD16SLS	16	1	38-1/2	29-5/16	47	193	233
MD20SLA	20	1	38-1/2	29-5/16	56	200	240
MD20SLS	20	1	38-1/2	29-5/16	56	208	248
MD24SLA	24	2	53-3/4	38-1/2	38-1/4	280	330
MD24SLS	24	2	53-3/4	38-1/2	38-1/4	288	338
MD28SLA	28	2	53-3/4	38-1/2	42-11/16	301	350
MD28SLS	28	2	53-3/4	38-1/2	42-11/16	309	358
MD32SLA	32	2	53-3/4	38-1/2	47-3/16	318	368
MD32SLS	32	2	53-3/4	38-1/2	47-3/16	326	376
MD36SLA	36	2	53-3/4	38-1/2	51-11/16	336	386
MD36SLS	36	2	53-3/4	38-1/2	51-11/16	344	394

MODELS *(Cont.d)*

MD__EL:
End Load Series

Model No.	Tray capacity 4-1/2" spacing	No. of Doors	Dimensions (inches)			Weight (lbs)	
			L	W	H	Net	Ship
MD14ELA	14	2	43-5/8	27-1/2	42-11/16	213	265
MD14ELS	14	2	43-5/8	27-1/2	42-11/16	221	273
MD18ELA	18	2	43-5/8	27-1/2	51-11/16	260	310
MD18ELS	18	2	43-5/8	27-1/2	51-11/16	268	318
MD24ELA	24	3	62-1/2	27-1/2	47-3/16	356	416
MD24ELS	24	3	62-1/2	27-1/2	47-3/16	364	424
MD27ELA	27	3	62-1/2	27-1/2	51-11/16	378	438
MD27ELS	27	3	62-1/2	27-1/2	51-11/16	386	446

OPTIONS AND ACCESSORIES

Aladdin offers a full complement of options and accessories for your Pellet System Delivery Carts.

Model No.	Description
MDTR	Two inch high top rail (all four sides)
MDTR3	Two inch high top rail (three sides)
MDSW6	Six wheel configuration for 6" Standard Balloon Casters (two door models only)
MD8W	Four 8" Standard Balloon Casters in lieu of 6" Standard Balloon Casters
MDSW8	Six wheel configuration for 8" Standard Balloon Casters
MDPW6	Four 6" Poly Casters in lieu of 6" Standard Balloon Casters
MDPSW6	Six wheel configuration for 6" Poly Casters
MDPW8	Four 8" Poly Casters in lieu of 6" Standard Balloon Casters
MDPSW8	Six wheel configuration for 8" Poly Casters
Contact Factory	Corner bumpers (set of 4)
Contact Factory	Vertical bumpers (set of 4)
Contact Factory	Rack hold down (per door, minimum 10 cart order)
Contact Factory	Stainless steel push handle(extra) each
Contact Factory	Top mount transport latch
Contact Factory	Side mount transport latch
Contact Factory	Tamper-proof screws
Contact Factory	Tow hitch (minimum 10 cart order)

RECEIVING INSPECTIONS

NOTE: *All Aladdin units are factory tested for performance and certified to be free from defects in material and workmanship when they leave the factory.*

ALADDIN DAMAGED GOODS POLICY

There are two types of damage that can occur during the shipment of your carts. They are visible damage to the outside packing and/or cart; and concealed damage that cannot be detected unless the packing is removed and the cart carefully inspected when received.

VISIBLE DAMAGE- (The product being received is visibly damaged).

1. The receiver should refuse the damaged merchandise.
2. Receiver should sign the bill of lading indicating which merchandise is being "refused due to damage".
3. Contact an Aladdin Customer Service Representative at (800)888-8018 and alert them to the situation.

CONCEALED DAMAGE- (Damaged merchandise cannot be externally detected).

Any receiving operation should inspect for this type of damage.

IF PRODUCT IS DAMAGED

1. Save all packing material.
2. Contact an Aladdin Customer Service Representative at (800)888-8018 and alert them to the situation.
3. **Receiver must call the carrier to schedule an inspection of the damaged merchandise within nine days.**

INSTALLATION

1. After removing the outside carton, remove all packing and strapping material from the exterior and interior of the unit.
2. Remove paper covering from unit.
3. Remove the unit from the shipping skid. This is done by tilting the unit and rolling it off the skid.
4. Install tray slider in position to accommodate either 15" x 20" or 14" x 18" trays.

OPERATION

1. For best results, insert loaded trays into the cart as quickly as possible. Doors should be opened only when necessary in order to help keep foods at the proper temperature and prevent contamination of foods from outside sources.
2. Avoid bumping carts into doors, walls or obstructions of any kind.
3. Never move cart unless all doors are secured in a open or closed position. Serious damage to hinges and doors may result if bumped into walls or other equipment when doors are open.

CLEANING



CAUTION



Harsh chemicals and insufficiently diluted sanitizers will damage stainless steel surfaces. Never use cleaning agents that contain phosphates or chlorides. These chemicals will cause permanent damage to the stainless steel finish, and void the equipment warranty.

The Aladdin SL Series and EL Series Pellet carts should be sanitized and cleaned after each use using the following method:

1. Tray slide assemblies are easily removed, without tools, for cleaning; simply lift up to release from bottom pin then push in to release from the top pin. The assemblies can now be pulled out the door opening. The assemblies should be hand washed.
2. Wipe walls, handles, and sides with a soft clean cloth, using warm water and a mild detergent. (Save time by wiping in a figure eight pattern.)
3. Use a soft nylon brush on any food buildup and in corners.
4. Sanitize with a properly diluted sanitizer that is recommended for stainless steel (according to chemical supplier's recommendations).
5. Allow water to drain through drain holes which are part of the cabinet floor.
6. Dry thoroughly with a dry cloth to remove moisture.
7. Never use sharp objects, abrasives or scrapers.

8. Do not wash cart in a pressurized wash system.

MAINTENANCE

LATCHES

1. Check frequently to ensure that all door latches are secure. Latches may become “sticky” due to residue build-up from daily use and cleaning.
2. Lubricate latches regularly with silicone spray. DO NOT use a petroleum based oil.

HINGES

1. The cart doors and hinges have been factory aligned with spacers to assure positive latching and smooth action. Be sure to replace these washers if they are removed when cleaning doors and hinges.
2. When doors are removed for cleaning, we recommend that they be put back on the same cart to assure the best possible alignment and operation.

CASTERS

1. Recommended lubrication is at least once every six months. Lubrication will be required at least every two weeks if carts are cleaned with a hot water or steam cleaning system. Using a standard 16 ounce grease gun, add two pumps of multi-purpose grease to the grease fitting on each caster.

PERIMETER BUMPERS

1. Vinyl bumpers that have been dislodged from the channel due to severe bumping or scraping can be reworked into place with a flat-blade screwdriver. Heating the vinyl bumper with hot water will soften the bumper and make this operation easier.

TROUBLESHOOTING

Performance problems often result from minor incidents that can be found and corrected by checking and following the basic points mentioned in the table below.

SYMPTOM	PROBABLE CAUSE	CORRECTION
Cart hard to push/pull.	Debris in caster. Caster bearings need lubrication.	Remove debris. Lubricate caster bearings.
Difficulty in opening/closing doors.	Hinges require lubrication. Improper alignment of hinges.	Lubricate hinges. Align hinges.
Trays do not slide easily into cart.	Tray slides dirty. Tray slides not seated properly.	Remove slides and clean. Correct alignment of tray slides.
Latch "sticky" does not operate smoothly	Residue buildup.	Clean and lubricate latch.

REPLACEMENT PARTS*

Side Load Models:

MD10SL, MD16SL, MD20SL, MD24SL,
MD28SL, MD32SL, MD36SL

- * Total part quantities vary according to model
- ** Vinyl perimeter bumper is sold by the foot
- MD10SL - MD20SL requires 14 ft.
- MD24SL - MD36SL requires 16 ft.

97268

97623

Item No.	Part No.	Description
1	97258	Stopper, rubber drain (c/w lanyard)
2	97243	Drain, stainless steel assembly
3	97244	Shock absorber, door
4	97269	Hinge, door, left top
5	97273	Hinge bracket, top left/lower right
6	97270	Hinge, door, left bottom
7	97272	Hinge bracket, top right/lower left
8	97269	Hinge, door, right top
9	97271	Hinge, door, right bottom
10	97263	Latch, door sliding
11	97274	Latch, receiver
---	97830	Cover, latch sst (not shown)
12	97264	Bumper, perimeter, vinyl (by foot) **
13	97259	Caster, 6" swivel (comes with brake)
14	97261	Caster, 8" swivel (comes with brake)
15	97260	Caster, 6" rigid
16	97262	Caster, 8" rigid
17	97266	Handle, push (See Note 1)
18	97267	Handle, push (MD24 thru MD36SL)
19	97553	Button assy, magnet
20	97278	Plate, magnet striker
21	97555	Pin, lower tray guide
22	97554	Pin, upper tray guide
23	97263	Handle, push (See Note 2)

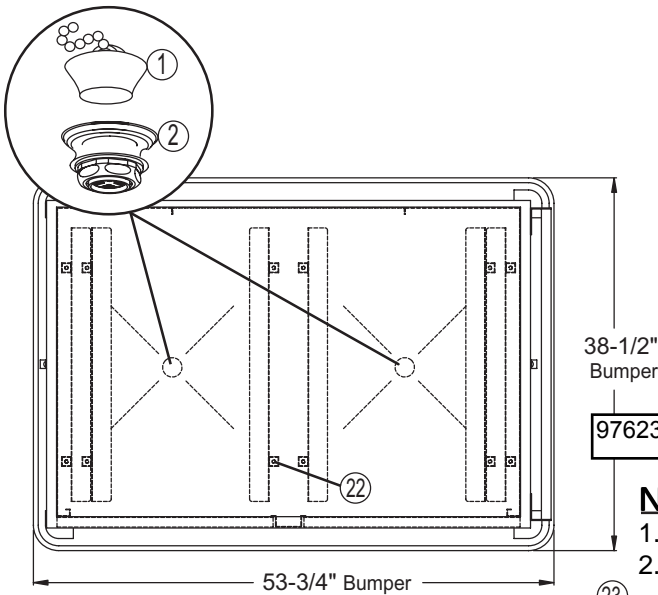

Notes:

1. All models except MD10SL prior to S/N A1562.
2. Model MD10SL beginning with S/N A1563 and above.

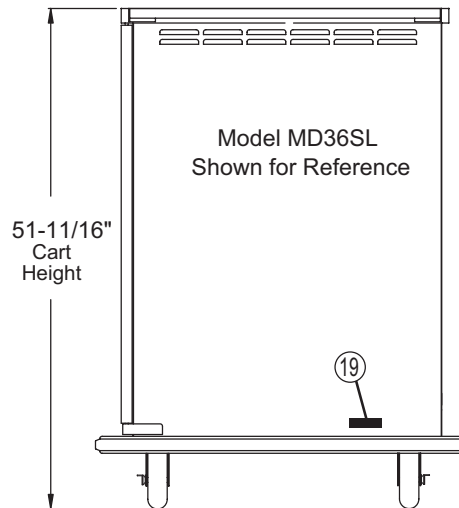
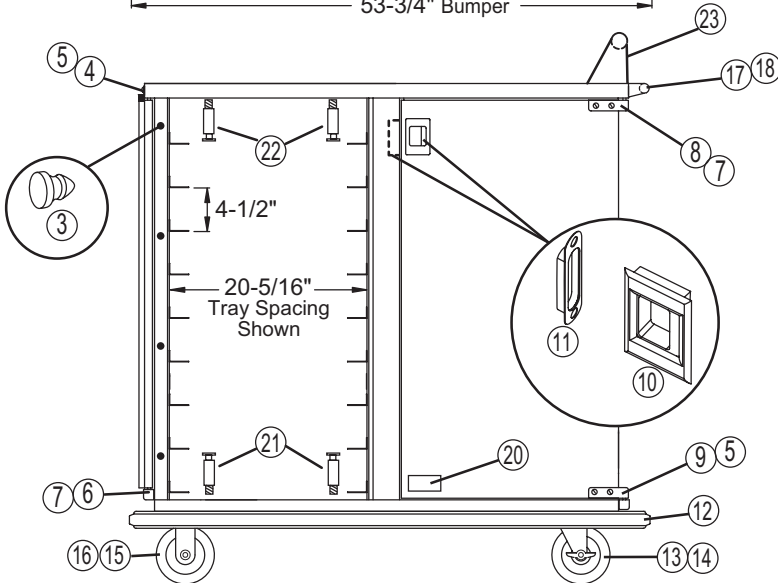

REPLACEMENT PARTS*

End Load Models:

MD14EL, MD18EL, MD24EL, MD27EL

** Vinyl perimeter bumper is sold by the foot
 MD14EL - MD18EL requires 12 ft.
 MD24EL - MD27EL requires 16 ft.

Item No.	Part No.	Description
1	97258	Stopper, rubber drain (c/w lanyard)
2	97243	Drain, stainless steel assembly
3	97244	Shock absorber, door
4	97269	Hinge, door, left top
5	97273	Hinge bracket, top left/lower right
6	97270	Hinge, door, left bottom
7	97272	Hinge bracket, top right/lower left
8	97269	Hinge, door, right top
9	97271	Hinge, door, right bottom
10	97263	Latch, door sliding
11	97274	Latch, receiver
---	97830	Cover, latch sst (not shown)
12	97264	Bumper, perimeter, vinyl (by foot) **
13	97259	Caster, 6" swivel (comes with brake)
14	97261	Caster, 8" swivel (comes with brake)
15	97260	Caster, 6" rigid
16	97262	Caster, 8" rigid
17	97266	Handle, push
18	97276	Button assy, magnet
19	97278	Plate, magnet striker
20	97275	End cap, tray post
21	97555	Pin, lower tray guide
22	97554	Pin, upper tray guide

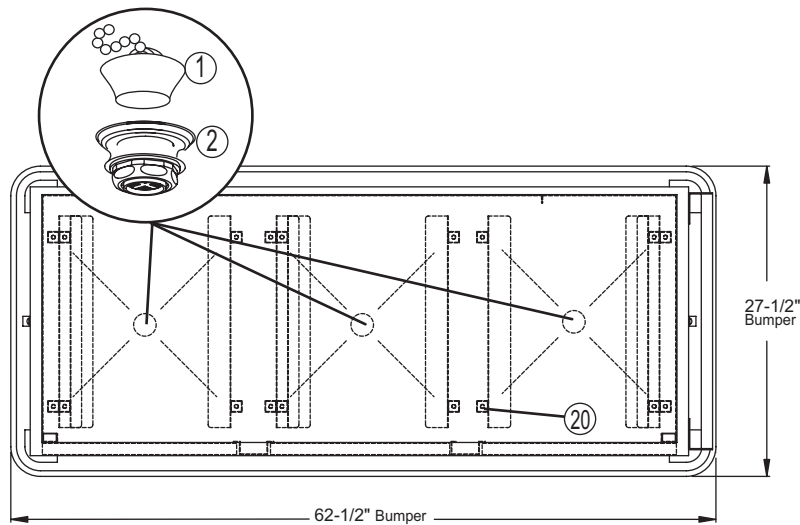

Model MD24EL Shown for Reference

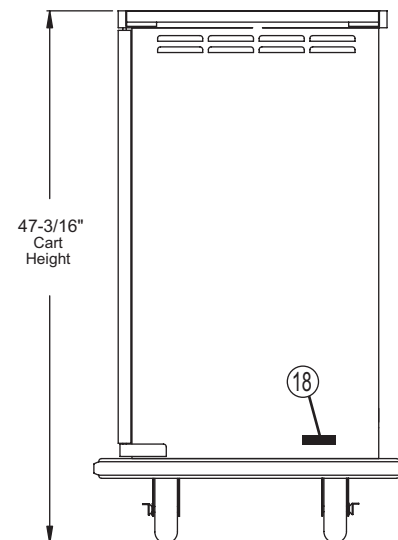
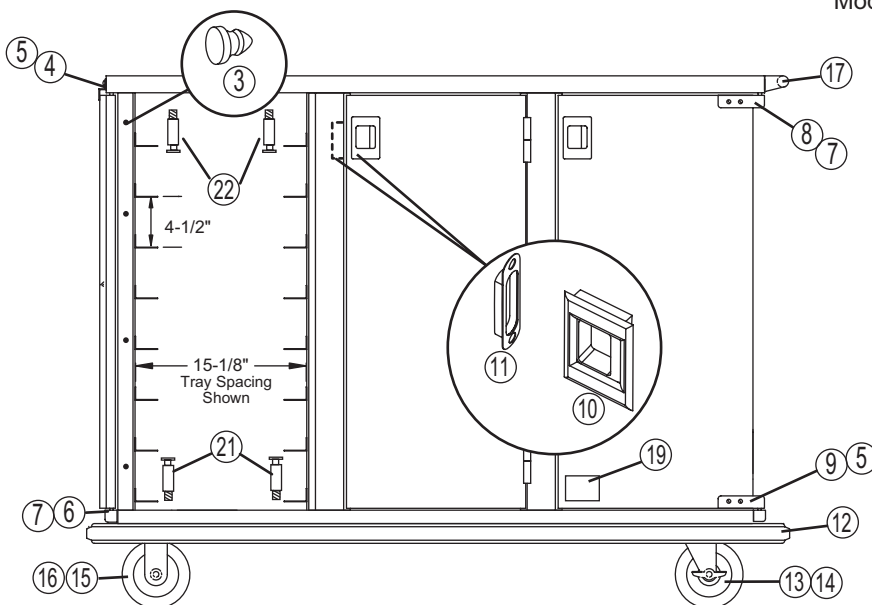

*Total part quantities vary according to model

**ALADDIN TEMP-RITE LLC
EQUIPMENT
LIMITED WARRANTY**

Effective January 1, 2004

The warranty term commences 30 days after Aladdin's invoice for the equipment.

Aladdin Temp-Rite LLC (Aladdin) warrants to the original purchaser that the equipment below shall be free from defects in material and workmanship under normal use for the applicable warranty term set forth below. Aladdin's obligation under this warranty is limited to the repair or replacement at the sole option of Aladdin, of any part which upon inspection and examination by Aladdin or its authorized agent is found to be defective. A written description detailing the nature of the claimed defect, together with the equipment claimed to be defective if required by Aladdin, must be delivered to Aladdin or its authorized agent within 30 days of discovery of the claimed defect (but in no event later than 30 days after the expiration of the applicable warranty term.

EQUIPMENT Add letter "A" after Model No. to denote aluminum base Add letter "S" after Model No. to denote SST base	WARRANTY TERM *		COMPRESSOR WARRANTY TERM * Parts Only **
	PARTS	LABOR	
MD14EL, MD18EL, MD24EL, MD27EL	1 year	90 days	N/A
MD16SL MD20SL MD24SL MD28SL, MD32SL, MD36SL	1 year	90 days	N/A

* The warranty term commences 30 days after Aladdin's invoice for the equipment.

** The compressor warranty covers the compressor only and does not include any shipping charges, other transportation costs, any external parts or electrical components, labor, refrigerants and taxes.

THE WARRANTIES AND REPRESENTATIONS OF ALADDIN CONTAINED HERE ARE EXPRESSLY IN LIEU OF, AND THE BUYER WAIVES ANY AND ALL OTHER WARRANTIES EXPRESS OR IMPLIED, INCLUDING THE WARRANTIES OF MERCHANTABILITY AND FITNESS FOR A PARTICULAR PURPOSE, AND ANY OTHER REMEDIES AGAINST ALADDIN, WHETHER BASED UPON CONTRACT, NEGLIGENCE STRICT LIABILITY OR OTHERWISE. ALADDIN SHALL NOT BE LIABLE FOR ANY CONSEQUENTIAL OR INCIDENTAL DAMAGES OR ECONOMIC LOSS OF ANY NATURE (INCLUDING WITHOUT LIMITATION LOSS OF REVENUES AND/OR PROFITS) THAT MAY BE CLAIMED TO RESULT FROM ANY NEGLIGENCE OR BREACH OF WARRANTY OR CONTRACT BY ALADDIN.

Exceptions and Exclusions

This warranty is issued only to the original purchaser, and is not transferable and applies only to the products installed within The United States of America, its territories, and Canada. During the term of any labor warranty, Aladdin will pay all pre-approved shipping charges incurred in returning defective equipment to Aladdin and labor costs incurred in the removal and reinstallation of such equipment. Contact Aladdin before returning any claimed defective equipment or otherwise performing warranty repairs. Aladdin assumes no liability for any work or repair performed without its prior approval. After the expiration of any labor warranty, the original purchaser is responsible for all shipping charges incurred in returning defective equipment to Aladdin and labor for removing and reinstalling such equipment. Aladdin shall not be responsible for the replacement of expendable item like lamps and fuses or product failure resulting from normal wear and tear, improper installation, misuse, sabotage, abuse, neglect accident, unauthorized alterations, or repair or other factors beyond the control of Aladdin. Neither this warranty nor the liability of Aladdin may be modified or extended by action of any agent, distributor or other person by custom or practice.

CALL THE ALADDIN TEMP-RITE TOLL FREE NUMBER AT 1-800-888-5426 IF YOU HAVE ANY QUESTIONS ABOUT THIS WARRANTY OR YOUR ALADDIN PRODUCT.

Revision History

Revision Date	Revised Pages	Serial Number Effectivity	Comments
12/19/03	All	A1000	First release of manual, P/N 97257 <i>Installation, Operation, & Maintenance Manual</i>
8/16/04	8-9	A1500	Added part nos. 97553, 97554 , 97555
10/19/04	8-9	A1562	Added P/N 97623.
1/20/05	8-9		Added P/N 97830.
10/6/05	8		Revised item 20 magnet part number 97278 .

Revision History *(cont.d)*

Aladdin Temp-Rite®

Aladdin Temp-Rite®
P.O. Box 2978
Hendersonville, TN 37077-2978
Tel: 1 (800) 888-8018
Fax: 1 (615) 537-3642

www.aladdintemprite.com



www.aligroup.it