



...better by degrees.

P.O. Box 2978, Hendersonville, TN 37077-2978
1-800-888-8018 or 615-537-3600
Fax 1-888-812-9956
www.aladdintemprite.com



DENESTED DELIVERY CARTS

Models: L03S and L04S



INSTALLATION GUIDE & OPERATING INSTRUCTIONS

Manual P/N 99761
Rev. C 05/22/2013

CONTENTS

I. MODELS	4
II. RECEIVING INSPECTIONS.....	5
III. INSTALLATION.....	6
IV. OPERATING INSTRUCTIONS.....	6
V. CLEANING / MAINTENANCE.....	6
VI TROUBLESHOOTING.....	6
VII. SERVICE	6
VIII. PARTS LIST.....	7
IX. WARRANTY.....	8

Model Number: _____

Serial Number: _____

Purchase Date: _____

Models: L03S and L04S *Denested Delivery Cart*

I. MODEL/DESCRIPTION

L0 Series Denested Cart Description

Denested Cart Specifications:

Model Number	L03S	L04S
Maximum Tray Capacity	12	20
Maximum Clearance between tray guides	4.937" (12.54 cm)	4.937" (12.54 cm)
Overall Width	28.125" (71.43 cm)	28.125" (71.43 cm)
Overall Length	36.312" (92.23 cm)	36.312" (92.23 cm)
Overall Height	42.09" (106.91cm)	63.437" (161.12 cm)
Approximate Shipping Weight	70 lbs (31.8 kg)	111 lbs (50.3 kg)
Shipping Cube (cubic feet)	30.61	42.1

Aladdin Temp-Rite® Denested Delivery Carts are designed to efficiently transport Aladdin Temp-Rite insulated tray systems to and from patient floors and dining areas. Each tray is individually suspended, allowing for the random selection of meals.

STANDARD FEATURES:

- All stainless steel construction
- Four 5" (12.7 cm) diameter casters, two fixed and two swivel with brake
- Formed in tray retainers to prevent trays from sliding out
- Non-marking corner bumpers
- Accommodates insulated tray sets between 19 3/4" (50.2 cm) and 21 1/2" (54.6 cm) long
- Recommended for the following Aladdin Temp-Rite Systems: Skandia, Century I, Bravo and Century II

II. RECEIVING INSPECTIONS

Your Aladdin Denested Delivery Carts are factory tested for performance and are free from defects when shipped. The utmost care has been taken in packaging this product to protect against damage in transit.

You should carefully inspect your unit to assure that no damage has occurred in transit. If however, damage is detected see the following damaged goods policy. Under no condition may a damaged unit be returned to Aladdin Temp-Rite without first obtaining written permission (return authorization). No credit will be issued for claims not reported to Aladdin within ten (10) business days from receipt of shipment.

ALADDIN DAMAGED GOODS POLICY

There are two types of damaged merchandise:

- Visual Damage
- Concealed Damage

Visual Damage – When the product being received is visibly damaged.

1. Receiver should not accept merchandise with visual damage.
2. Receiver must sign delivery receipt “refused merchandise due to damage” and specify damage.
3. Receiver should call Aladdin Customer Service immediately after refusal.
4. Carrier will notify Aladdin Traffic Department and a claim will be filed.
5. Carrier will send acknowledgement of claim within 7 days after receiving.

Concealed Damage – When damaged merchandise cannot be externally detected.

Any receiving operation should be looking for this type of damage. Sometimes, however, depending on the type of product, it is almost impossible to notice.

1. Merchandise must not be removed from point of delivery and all packaging must be kept intact.
2. Receiver must contact Aladdin customer service to report damage.
3. Aladdin traffic department will request inspection based on the dollar value of the cargo.
4. Aladdin traffic department will file a claim based on the findings of the inspection.

Failure to comply with these policies will result in the customer’s responsibility to file claims.

Models: L03S and L04S *Denested Delivery Cart*

III. INSTALLATION

- A. Remove all packaging and strapping material from the exterior of the unit.
- B. Remove the unit from the skid.

IV. OPERATING INSTRUCTIONS

IMPORTANT NOTE:

Trays should not be transported on top of cart.

- A. Ensure that all trays are secure before moving cart
- B. Avoid bumping carts into, doors or obstacles

V. CLEANING / MAINTENANCE



CAUTION

Harsh chemicals and insufficiently diluted sanitizers will damage chrome plated or stainless steel surface. Never use cleaning agents that contain phosphates or chlorides. These chemicals will cause permanent damage to chrome or stainless steel finish, and void equipment warranty.

Clean any debris from the frame and racks then wipe complete unit with a damp cloth.

- Use warm water with mild detergent and soft cloth and dry.
- Use of high pressure sprayers or cart washing machines for cleaning will void the warranty.

VI. TROUBLESHOOTING

COMPLAINT	PROBLEM	SOLUTION
Unit does not roll easily	Debris in caster	Clean caster housing and caster

VII. SERVICE

If you need assistance, call the Aladdin Temp-Rite® Toll Free Service Line, 1-800-888-5426.

VIII. PARTS LIST

Item	Description	Part Number
1	5" Diameter swivel caster with brake	92516
2	5" Diameter rigid caster	97228
3	Tray guide universal NOTE: To replace drill out rivets of damaged tray guide attach with new rivets	99760
4	SS Pop Rivet 1/4" x 1/4" x 5/16" Al	12113
5	Corner bumper	93052
6		

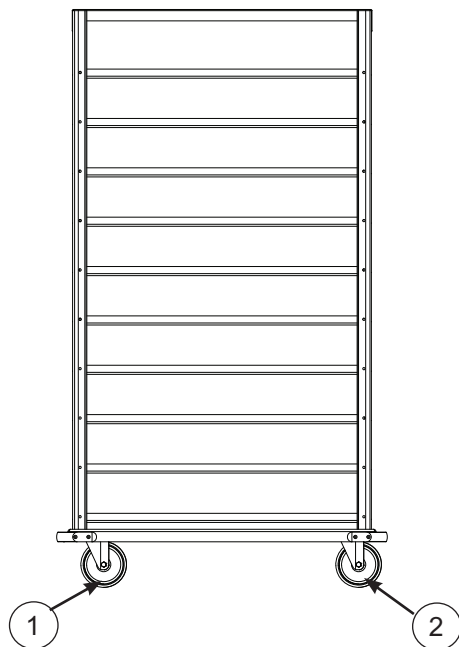
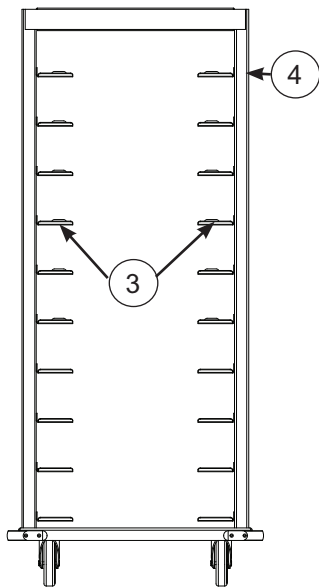
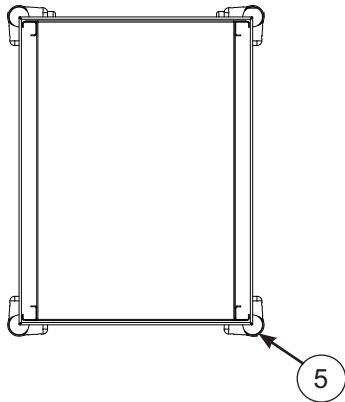

Models: L03S and L04S *Denested Delivery Cart*

IX. WARRANTY

ALADDIN TEMP-RITE®
EQUIPMENT
LIMITED WARRANTY

Effective September, 2009

Aladdin Temp-Rite® (“ATR”) warrants to the original purchaser that the equipment listed below shall be free from defects in material and workmanship under normal use for the applicable warranty term set forth below. ATR’s obligation under this warranty is limited to the repair or replacement, at the sole option of ATR, of any part which upon inspection and examination by ATR or its authorized agent is found to be defective. A written description detailing the nature of the claimed defect, together with the equipment claimed to be defective if required by ATR, must be delivered to ATR or its authorized agent within 30 days of discovery of the claimed defect (but in no event later than 30 days after the expiration of the applicable warranty term).

EQUIPMENT	WARRANTY TERM*	
	PARTS	LABOR
L03S	1 Year	90 Days
L04S	1 Year	90 Days

*The warranty term commences 30 days after the date of ATR’s invoice for the equipment.

THE WARRANTIES AND REPRESENTATIONS OF ATR CONTAINED HEREIN ARE EXPRESSLY IN LIEU OF, AND THE BUYER WAIVES, ANY AND ALL OTHER WARRANTIES EXPRESS OR IMPLIED, INCLUDING THE WARRANTIES OF MERCHANTABILITY AND FITNESS FOR A PARTICULAR PURPOSE, AND ANY OTHER REMEDIES AGAINST ATR, WHETHER BASED UPON CONTRACT, NEGLIGENCE, STRICT LIABILITY OR OTHERWISE. ATR SHALL NOT BE LIABLE FOR ANY CONSEQUENTIAL OR INCIDENTAL DAMAGES OR ECONOMIC LOSS OF ANY NATURE (INCLUDING WITHOUT LIMITATION LOSS OF REVENUES AND/OR PROFITS) THAT MAY BE CLAIMED TO RESULT FROM ANY NEGLIGENCE OR BREACH OF WARRANTY OR CONTRACT BY ATR.

Exceptions and Exclusions

This warranty is issued only to the original purchaser, and is not transferable and applies only to the products installed within the United States of America, its territories and Canada. During the term of any labor warranty, ATR will pay all pre-approved shipping charges incurred in returning defective equipment to ATR and labor costs incurred in the removal and reinstallation of such equipment. Contact ATR before returning any defective equipment or otherwise performing any warranty repairs. ATR assumes no liability for any work or repair performed without its prior approval. After the expiration of any labor warranty, the original purchaser is responsible for all shipping charges incurred in returning defective equipment to ATR and labor for removing and reinstalling such equipment. ATR shall not be responsible for the replacement of expendable items like lamps and fuses or product failure resulting from normal wear and tear, improper installation, misuse, sabotage, abuse, neglect, accident, unauthorized alterations to repair, or other factors beyond the control of ATR. Neither this warranty, nor the liability of ATR may be modified or extended by action of any agent, distributor or other person or by custom or practice.

CALL ATR TOLL FREE AT 1-800-888-5426 IF YOU HAVE ANY QUESTIONS ABOUT THIS WARRANTY OR YOUR ATR PRODUCT.