

8 7 6 5 4 3 2 1

D
C
B
A

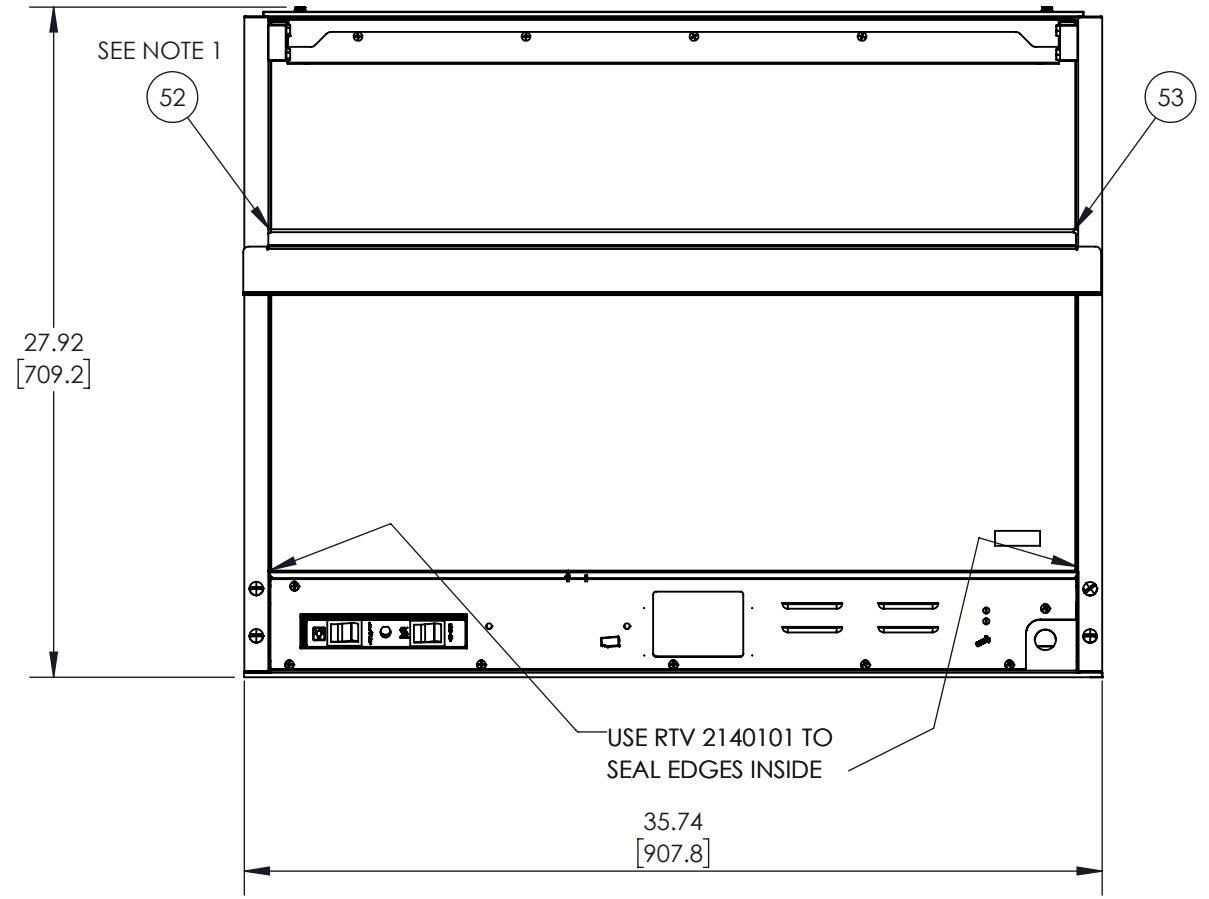
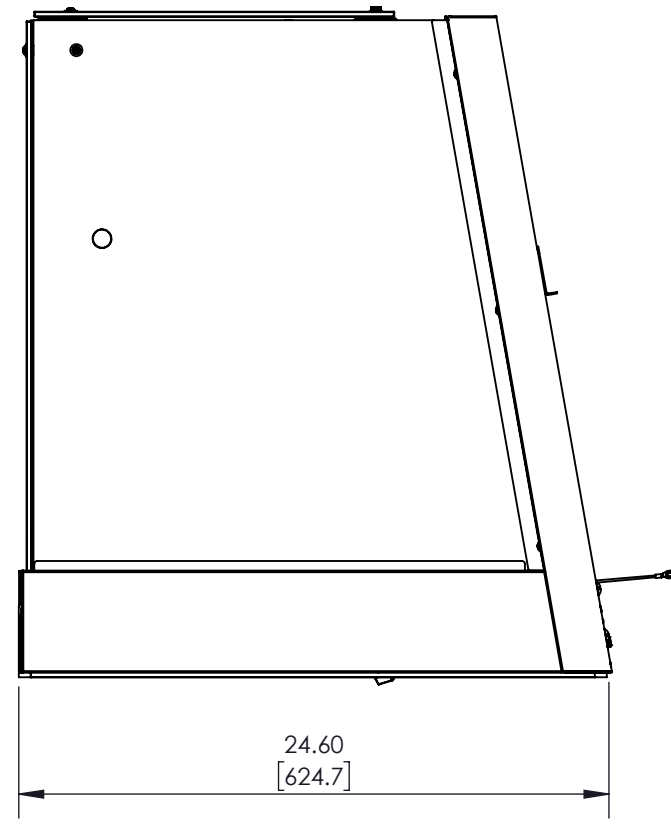

NOTE:
1. INSTALL GLASS RETAINERS 0013683 AND 0013684 BEFORE MOUNTING 0507482 PACKAGING BRACE.

REV	DATE	PCO NO.	DESCRIPTION	BY
J	7/30/18	PC-15305	REDRAWN IN SOLIDWORKS	JP
I	05/24/17	PC-14062	I1 ADDED 0013683, 0013684, 0013450, 3080358, 3080359, 0022701 & 0022702; I2 REMOVED 0022173; I3 QTY 2100360 WAS 8; I4 ADDED NOTE 5; I5 REVISED 0013157 & 0507482. REMOVED P/N 2140109	RLC

THE INFORMATION AND DESIGNS CONTAINED IN THIS DRAWING ARE CONFIDENTIAL AND THE PROPRIETARY PROPERTY OF A.J. ANTUNES & CO. NEITHER THIS DESIGN NOR ANY INFORMATION CONTAINED HEREIN MAY BE REPRODUCED OR DISCLOSED TO OTHERS WITHOUT THE EXPRESS WRITTEN CONSENT OF A.J. ANTUNES & CO.

UNLESS OTHERWISE SPECIFIED:
INTERPRET DIMENSIONS AND TOLERANCES PER ASME Y14.5-2009
ALL DIMENSIONS: INCH [mm]
TOLERANCES:
FRACTIONS ±1/32" [.8mm]
DECIMAL
.xx ±.01" [.25mm]
.xxx ±.005" [.125mm]
ANGULAR: ±1°
NO BURRS ALLOWED
BREAK ALL SHARP CORNERS

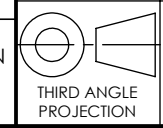

DO NOT SCALE DRAWING

DRAWN BY: AMS
APVD BY:
DATE: 4/20/2015
DATE:



PART DESCRIPTION:
DCH-800 DISPLAY CASE

MATERIAL SPECIFICATION:

SIZE: **B** SCALE: 1:8 PART NUMBER: 0013126 REV: J

SHEET 1 OF 2

8 7 6 5 4 3 2 1

ITEM NO.	PART NUMBER	DESCRIPTION	QTY.	ITEM NO.	PART NUMBER	DESCRIPTION	QTY.	ITEM NO.	PART NUMBER	DESCRIPTION	QTY.
54	0022702	WELDMENT, CORNER BRKT LH	1	42	1001601	LABEL-WIRING DIAGRAM	1	1	0022145	UPRIGHT WLMT RH	1
55	3080359	8-32 x .50 LG PH S.S. EPOXY-LOCK PATCH	4	43	3250206	SCR TRHD 1/4-20 X 2.5 SLOTTED SST	4	2	0013162	CONTROL PANEL ASSY 36"	1
56	3080358	8-32 x .38 LG PH S.S. EPOXY-LOCK PATCH	2	44	3250207	WASHER, FLAT 1/4 x 1/32 THICK PLASTIC	8	3	0022124	UPRIGHT TUBE WLDMT LH	1
57	0013144	POWER SUPPLY ASSY	1	45	2150152	BEARING, 1/4ID X 19/64OD	2	4	0013160	LIGHT MOUNT ASSY 36"	2
58	0400147	BUSHING, SHORTY 7/8	1	46	0400466	GROMMET, SPLIT 1/2"	1	5	0022169	SHELF SUPPORT WLDMT LH	1
59	3080157	SCREW, TAP 8-32 X 3/8"LG	19	47	5206034	SPIRAL WRAP 6" PTFE	1	6	0022069	SHELF SUPPORT WELDMENT RH	1
60	3250193	SCREW, HEX HEAD, 1/4-20 X 1.375 SCREW	8	48	3060179	#6-32 SET SCREW 3/16"LG W/NUT ON TIP	3	7	0022131	TOP SUPPORT WLDMT RH	1
61	3080143	NUT, HEX 'KEPS' #8-32	3	49	0507482	36" PACKAGING BRACE	1	8	0022130	TOP SUPPORT WLMT LH	1
62	2140101	ADHESIVE/SEALAN-RTV	A/R	50	0013683	GLASS RETAINER ASSY LH	1	9	0022147	TOP GLASS SUPPORT WELDMENT	1
63	2150410	ADHESIVE PERMABOND	A/R	51	0013684	GLASS RETAINER ASSY RH	1	10	0013300	ANGLE ASSY RH	1
64	2140138	LOCTITE #262(REDF)PERM.	A/R	52	0013450	LOCK PADDLE ASSEMBLY	2	11	0013299	ANGLE ASSY LH	1
65	0700980	DC PLUG 90 DEGREE	1	53	0022701	WELDMENT, CORNER BRKT RH	1	12	0900319	SIDE GLASS	2

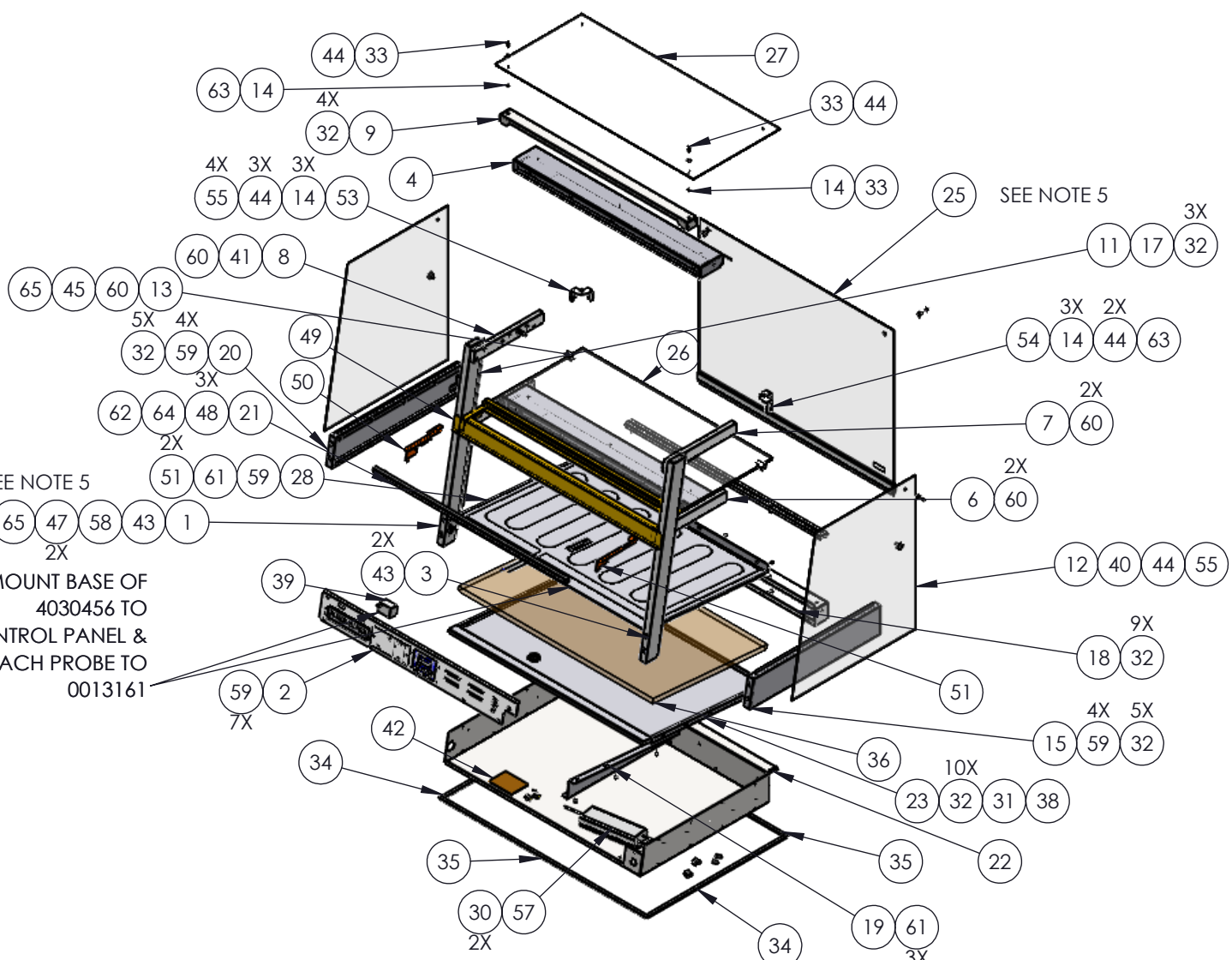

13	0013320	GLASS MT ASSEMBLY	2
14	2150410	SPACER SLEEVE	6
15	0022071	LH GLASS SUPPORT WLDMT	1
16	0507165	INSIDE ANGLE RH	1
17	0507166	INSIDE ANGLE LH	1
18	0507206	FRONT SUPPORT BRKT 36"	1
19	0507071	Z BRACKET	1
20	0022070	RT GLASS SUPPORT WLDMT	1
21	0013158	LIGHT CHANNEL ASSY 36"	1
22	0022148	BOTTOM TRAY WELDMENT	1
23	0507204	HEATER BASE	1
24	0013129	BASE HINGE ASSEMBLY 33.69" LG	1
25	0013157	FRONT GLASS ASSY	1
26	0900328	MID SHELF 36"	1
27	0900327	TOP GLASS 36"	1
28	0013161	HEATER ASSY 36"	1
29	3100146	NUT, HEX "KEPS" #10-32	5
30	3060101	NUT,HEX #6-32 ST.STL	2
31	0400432	BUSHING, OPEN/CLOSED	1
32	3080203	SCREW #8-32 x 3/8 WITH INT. TOOTH WASHER	41
33	2100360	#8-32 KNURL KNOB	2
34	0200348	GASKET, 23.5"	2
35	0200349	GASKET, 35.75"	2
36	0400471	INSULATION	1
37	4050226	PROBE, THERMISTOR	1
38	0507070	THERMO PLATE	1
39	4030456	THERMOSTAT HI-LIMIT	1
40	2000253	MTG HARDWARE FOR 2000252	2
41	0700934	CABLE, DC PLUG, 18AWG WIRE	2



NOTE:
1. ASSEMBLE 0022070 AND 0022071 TO 0507206 FIRST. NEXT ASSEMBLE 0022148. ADD ITEMS 34 AND 35 TO BOTTOM OF BASE. CLEAN WITH ALCOHOL FIRST.
2. ALIGN 0022130, 0022131, 0022169 AND 0022173 WITH A LEVEL WHILE ATTACHING TO UPRIGHTS 0022145 AND 0022124.
3. WRAP SPIRAL WRAP 5206034 AROUND WIRES EXCITING 0022145 AND PLACE AT BOTTOM OF TUBE WELDMENT TO PROTECT FROM SCREWS 3250203.
4. USE RTV 2140101 TO FILL SET SCREW HEX HEAD AFTER INSTALLING 3060179.
5. MOUNT FRONT GLASS ASSEMBLY 0013157 WITH THE SHOULDER SPACERS FACING OUTSIDE.

REV	DATE	PCO NO.	DESCRIPTION	BY
J	7/30/18	PC-15305	REDRAWN IN SOLIDWORKS	JP
I	05/24/17	PC-14062	11 ADDED 0013683, 0013684, 0013450, 3080358, 3080359, 0022701 & 0022702; I2 REMOVED 0022173; I3 QTY 2100360 WAS 8; I4 ADDED NOTE 5; I5 REVISED 0013157 & 0507482. REMOVED P/N 2140109	RLC

THE INFORMATION AND DESIGNS CONTAINED IN THIS DRAWING ARE CONFIDENTIAL AND THE PROPRIETARY PROPERTY OF A.J. ANTUNES & CO. NEITHER THIS DESIGN NOR ANY INFORMATION CONTAINED HEREIN MAY BE REPRODUCED OR DISCLOSED TO OTHERS WITHOUT THE EXPRESS WRITTEN CONSENT OF A.J. ANTUNES & CO.

UNLESS OTHERWISE SPECIFIED: INTERPRET DIMENSIONS AND TOLERANCES PER ASME Y14.5-2009 ALL DIMENSIONS: INCH [mm] TOLERANCES: FRACTIONS ±1/32" [.8mm] DECIMAL .xx ±.01" [.25mm] .xxx ±.005" [.125mm] ANGULAR: ±1°		DRAWN BY: AMS	APVD BY:	 Antunes ISO COMPLIANT COMPANY 180 KEHOE BLVD, CAROL STREAM, IL 60188
NO BURRS ALLOWED BREAK ALL SHARP CORNERS		DATE: 4/20/2015	DATE:	
 THIRD ANGLE PROJECTION		DO NOT SCALE DRAWING		PART DESCRIPTION: DCH-800 DISPLAY CASE
MATERIAL SPECIFICATION:		SIZE: B	SCALE: 1:20	
REV: J		SHEET 2 OF 2		