



**Partstown**

Get real parts faster

## Refrigeration Service and Parts Book

# CULITEK



# 65" Horizontal Bottle Cooler

## Admiral Craft Model: U-STAR USBC-65

U-STAR Bottle Cooler, flat top, 65"W, 19 cu.ft., (2) lockable stainless steel sliding lids, (4) plastic coated steel dividers, side mount self-contained refrigeration, automatic defrosting, built-in bottle opener with cap catcher, painted aluminum interior liner, black coated steel exterior, R290, 115v/60/1-ph, 2.6 amps, 1/6 HP, 7' cord, NEMA 5-15P, cETLus, ETL-Sanitation.



## Culitek Model: MBC-65

Culitek Bottle Cooler, flat top, 65"W, 19 cu.ft., (2) lockable stainless steel sliding lids, (4) plastic coated steel dividers, side mount self-contained refrigeration, automatic defrosting, built-in bottle opener with cap catcher, painted aluminum interior liner, black coated steel exterior, R290, 115v/60/1-ph, 2.6 amps, 1/6 HP, 7' cord, NEMA 5-15P, cETLus, ETL-Sanitation

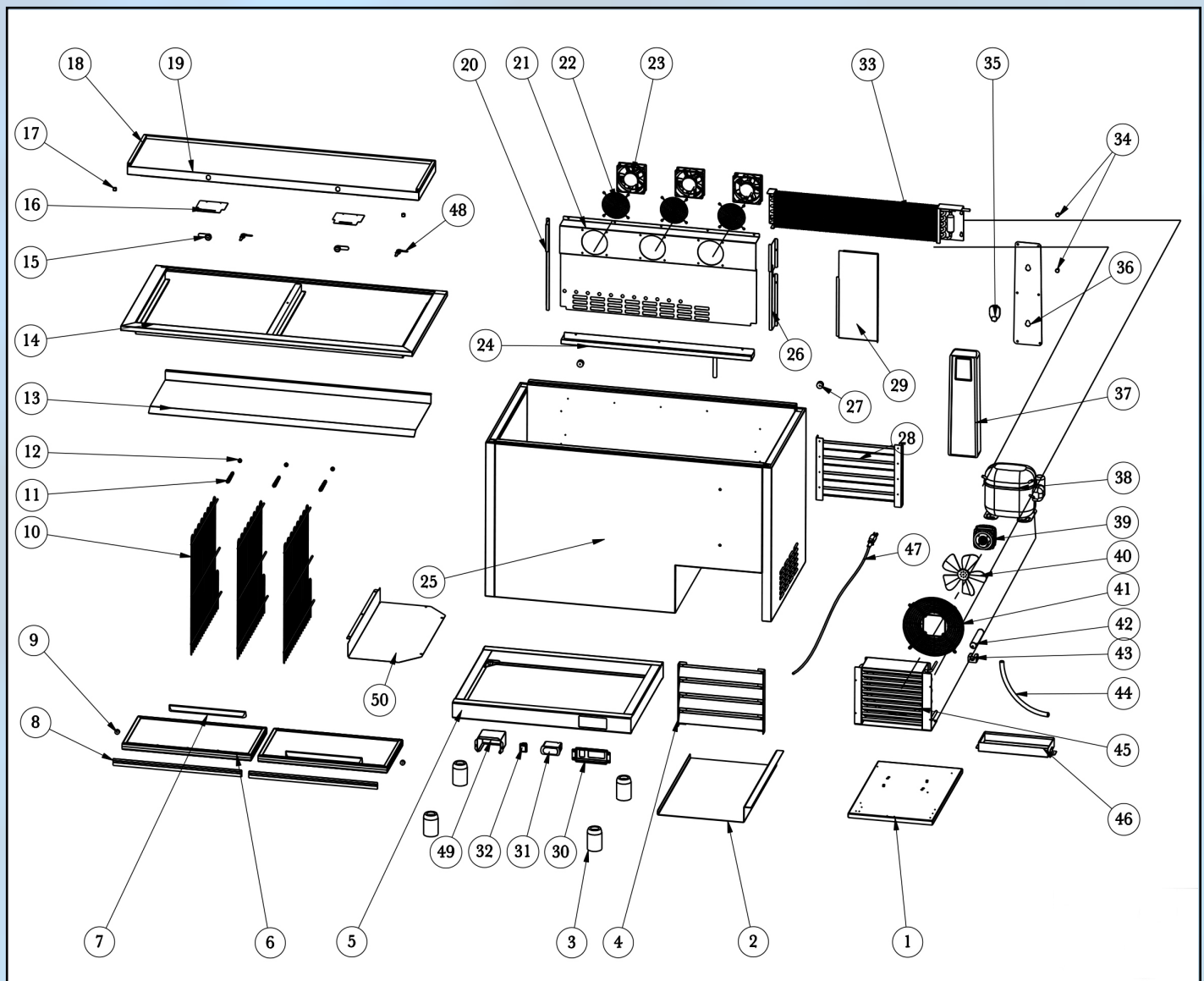

Diagram #	Part Description	Quantity per Item	Part #
1	COMPRESSOR UNIT INSTALLATION BOARD	1	
2	BASE BOARD	1	
3	LEVELING FEET	5	AF-1
4	FRONT GRILL	1	
5	CABINET BASE	1	
6	DOOR	2	DOOR-26
7	DOOR HANDLE	2	DOOR-26
8	DOOR GASKET	2	GAS-34
9	DOOR LIMIT BLOCK	2	
10	SHELF	3	SHELF-28
11	SHELF SPRING	3	
12	SHELF CAP	51	
13	PANEL UNDER TABLE	1	
14	UNDER TABLE COMPONENT	1	
15	LOCK	2	RF-KEYS
16	BASE BOARD FOR LOCK	2	
17	DECORATION COVER	2	
18	DECORATION STRIP	1	
19	TOP BOARD	2	
20	LEFT SUPPORT FOR EVAPORATOR COVER	1	
21	EVAPORATOR COVER	1	
22	EVAPORATOR FAN MOTOR COVER	3	
23	EVAPORATOR FAN MOTOR	3	EVP-1
24	INNER DRAIN PAN	1	
25	CABINET	1	
26	RIGHT SUPPORT FOR EVAPORATOR COVER	1	
27	BACK LIMIT BLOCK	2	
28	BACK GRILL	1	
29	INNER BAFFLE	1	
30	THERMOSTAT INSTALLATION COVER	1	
31	THERMOSTAT	1	CAR-3
32	POWER SWITCH	1	PS-1
33	EVAPORATOR	1	EVC-17
34	SCREW FOR BOTTLE OPENER COMPONENT	2	
35	BOTTLE OPENER	1	
36	BOTTLE OPERER BOARD	1	
37	BOTTLE OPENER COVER	1	
38	COMPRESSOR	1	COMHC-19
39	CONDENSER FAN MOTOR	1	CON-4
40	CONDENSER FAN BLADE	1	
41	CONDENSER FAN MOTOR COVER	1	
42	FILTER	1	
43	FILTER FIXER	1	
44	DRAIN TUBE	1	
45	CONDENSER	1	COND-1
46	OUTER DRAIN PAN	1	
47	POWER CORD	1	
48	KEY	2	RF-KEYS
49	THERMOSTAT WATER PROOF COVER	1	
50	THERMOSTAT BAFFLE	1	

# FREQUENTLY ASKED QUESTIONS FOR REFRIGERATION

## How do I set the temperature?

### TEMPERATURE CONTROLS

The temperature controls are factory set to 33°F for refrigerators and -7°F for freezers.

FREEZER CONTROL



REFRIGERATOR CONTROL

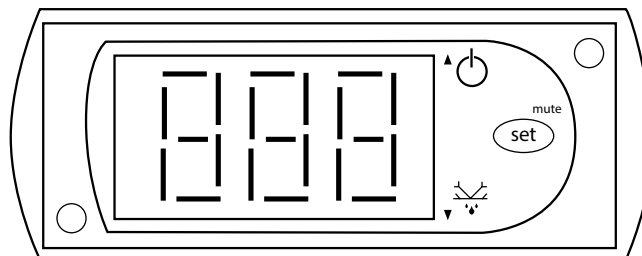

### Regulating the Temperature

Your new refrigerator or freezer is now manufactured to run at ideal temperatures for food quality and should not require any alterations.

Refrigerators are set to cycle between a base temperature of 33° Fahrenheit and a temperature maximum of 41° Fahrenheit.

Freezers are set to cycle between a base temperature of - 8 degrees Fahrenheit and a greatest temperature of 0 degrees Fahrenheit.

Altering the temperature changes the base temperature your unit will keep running at. Your unit won't run always at this setting. To change it, follow these instructions:

- Hold "SET" for 1 sec. The display will flash the temperature that the refrigerator is currently set to.
- Use the arrow buttons to adjust the temperature
- Press "SET" to save your settings

## Can I reverse the swing of the door?

### FIELD REVERSIBLE DOORS

The one door solid upright reach-ins are designed with a right-hinged door design by default. If you would like to convert the reach-in to a left hinged door design, you must purchase a bottom hinge separately and follow the instructions below:

### Tools Required for Door Reversal:

- Socket set
  - Pliers
  - Adjustable wrench
  - Phillips head screwdriver
1. Remove the bottom vent, which is held on by loosening the screws that hold it on. You do not need to remove the whole way, as the vent will slide up and out.
  2. Remove the top panel next. It is held on with two small screws. Once the screws are out, the top panel will hinge up.
  3. Remove the small screws at the top and bottom door hinge where it attaches to the brackets.
  4. Next take off the top bracket. It is held on with 3 bolts.
  5. The door should come off at this point. Do not lose the small round brass spacer on the bottom hinge.
  6. Remove the bottom bracket. It is held on with 3 bolts.
  7. Replace the bottom hinge with the new left hand bottom bracket. It is held on with 3 bolts.
  8. At this point, you will need to adjust the top and bottom spring tensioners so the door will close properly.
  9. Put the door on the bottom hinge on the left side. You will need to reuse the brass spacer from step 5.
  10. Next, place the top bracket on the top of the door before bolting it to the unit with the 3 bolts.
  11. Replace the small screws on the top and bottom of the bracket and door spring. Make sure the door is on correctly before doing this.
  12. Re-attach the bottom vent and the top panel.

## ***Why is my unit increasing in temperature when nothing is in it?***

Your unit has a differential that is displayed your unit will cycle up 7 degrees from your set point before your compressor comes on.

## ***Why can't I open the door right away?***

The door hermetically seals for 10 to 14 seconds after closing to suck the air out of the unit.

## ***Why do sometimes I hear a gurgling noise when I close the door?***

If your unit is in the process of a defrost you will have water in your pan when the door is shut and sucking out the air of the unit it will sometimes cause the water to go down the drain too fast causing a gurgling noise.

### **REGULAR MAINTENANCE**

**WARNING:** Disconnect power cord before cleaning any parts of the unit.

#### **CLEANING THE CONDENSER COIL**

For efficient operation, it is important that the condenser surface be kept free of dust, dirt, and lint. It is highly recommended that the condenser coil be cleaned at least once a month. Clean with a commercial condenser coil cleaner and brush the condenser fins from top to bottom. After cleaning, straighten any bent fins with a fine comb.

#### **CLEANING THE FAN BLADES AND MOTOR**

If needed, clean the fan blades and motor with a soft cloth if there is any build up. If it is necessary to wash the fan blades, cover the fan motor first to prevent any kind of moisture damage.

#### **CLEANING THE INTERIOR OF THE UNIT**

When cleaning the cabinet interior, use a mixture of mild soap and warm water. It is not recommended to use steel wool, caustic soap, abrasive cleaners, or bleach as this may cause damage to the stainless steel surface.

Wash door gaskets on a weekly basis. Remove the door gasket from the frame of the door, soak in a mixture of mild soap and warm water for 30 minutes and dry with a soft cloth.

- Place back on the door and check that the gaskets form a proper seal after they are replaced.
- Periodically remove the shelves and pilasters from the unit and clean them with a mild soap and water mixture.
- To remove the pilasters, first remove the shelves and [shelf](#) brackets. Then lift the pilaster up and out.

## TWO YEAR WARRANTY

Culitek warrants to the original purchaser of this unit, the cabinet and all parts thereof, to be free from defects in material or workmanship, under normal use and service, for a period of two (2) years from the date of original purchase.

Any parts covered by this warranty that are examined and determined to have been defective within two (2) years of original purchase shall be repaired or replaced as stated below. Shall be deemed to have fully complied with its obligation under the foregoing warranties by electing either one of the following procedures

1. Furnishing a replacement part, freight collect, in even exchange for the returned part, freight collect.
2. Receiving the defective part, freight collect; repairing it; and returning it, freight collect.

## ADDITIONAL THREE YEAR COMPRESSOR PART WARRANTY

In addition to the (2) two year warranty stated above, Culitek warrants its hermetically and semi-hermetically sealed compressor to be free from defects in both material and workmanship under normal use and service for a period of three (3) additional years from the date of original purchase but not to exceed five (5) years and three (3) months after shipment from manufacturer.

Compressors determined to have been defective within this extended time period will be either repaired or replaced with a compressor or compressor parts of similar design and capacity.

The three (3) year extended compressor warranty applies only to hermetically and semi-hermetically sealed parts of the compressor and does not apply to any other parts or components, including, but not limited to, cabinet, paint finish, temperature control, refrigerant, metering device, driers, motor starting equipment, fan assembly any other electrical component, etc.

## R290 COMPRESSOR WARRANTY

The three year compressor warranty detailed above will be voided if the following procedure is not carefully adhered to:

1. This system contains R290 refrigerant and polyester lubricant. The polyester lubricant has rapid moisture absorbing qualities. If long exposure to ambient conditions occur, the lubricant must be removed and replaced with new lubricant. Failure to comply with recommended lubricant specification will void the compressor warranty.
2. Dryer replacement is very important and must be changed when a system is opened for servicing. Dryer must be used with XH-9 desiccant.
3. Micron level vacuums must be achieved to insure low moisture levels in the system. 500 microns or lower must be obtained.

## WHAT IS NOT COVERED BY THIS WARRANTY

Obligation under warranty is limited to either repair or replacement of parts, subject to the additional limitations below. This warranty neither assumes nor authorizes any person to assume obligations other than expressly covered by this warranty.

1. **WARRANTY IS NOT TRANSFERABLE.** This warranty is not assignable and applies in favor of the original purchaser/user to whom delivered. Any such assignment or transfer shall void the warranties herein made and shall void all warranties, express or implied, including any warranty of merchantability or fitness for a particular purpose.
2. **NO CONSEQUENTIAL DAMAGES.** Not responsible for economic loss: profit loss or special, indirect, or consequential damages, including without limitation, losses or damages arising from food or product spoilage claims whether or not on account of refrigeration failure.
3. **ALTERATION, NEGLIGENCE, ABUSE, MISUSE, ACCIDENT, DAMAGE DURING TRANSIT OR INSTALLATION, FIRE, FLOOD, ACTS OF GOD.** Not responsible for the repair or replacement of any parts that have been subjected after the date of manufacture to alteration, neglect, abuse, misuse, accident, damage during transit or installation, fire, flood, or an Act of God.
4. **NO IMPLIED WARRANTY OF MERCHANTABILITY OR FITNESS FOR A PARTICULAR PURPOSE.** There are no other warranties, express, implied or statutory, except the two (2) year warranty and the additional three (3) year compressor warranty as described above. These warranties are exclusive and in lieu of all other warranties, including implied warranty and merchantability or fitness for a particular purpose. There are no warranties which extend beyond the description on the face hereof.
5. **TRANSPORTATION COSTS.** Will accept parts covered under this warranty freight collect, provided that shipment has received prior approval. Not responsible for any other transportation costs, but will ship freight collect parts either repaired or replaced under these warranties.
6. This equipment is intended for commercial use only and this warranty is void if equipment is used in a residential or non-commercial application.

This warranty covers products shipped into the 48 contiguous United States. Warranty coverage on products used in Hawaii, Alaska, Puerto Rico, and Canada cover parts only.

Equipment installed in/on a food truck or trailer will be limited to a period of 30 days from the original date of purchase.

## WARRANTY CLAIMS & SERVICE

For all warranty claims please have the model number, serial number and a proof of purchase available.

**Phone: 1-800-325-1740**

For all online warranty claims please include the model number, serial number and detailed description of the issue.

Please attach a copy of your proof of purchase with your e-mail.

**E-Mail: [customerservice@partstown.com](mailto:customerservice@partstown.com)**



# Admiral Craft

---

Equipment Corp.

In business since 1952, Admiral Craft Equipment Corp. is a leading manufacturer of equipment, smallwares and supplies to the commercial foodservice industry. Offering in excess of 2,000 products, our mission is to provide quality products at a competitive price, while maintaining superior customer service, prompt shipment and an exceptional fill rate.

Admiral Craft's product line is continually evolving and now boasts the widest range of commercial foodservice products in the industry. With offices and 12 strategically placed warehouses throughout the country, Admiral Craft is able to provide quick and efficient shipment to customers, no matter their location.

**Contacts for Admiral Craft:**

Suzanne Condon - Director of Field Services  
*scondon@admiralcraft.com*

Michael McAssey - Lead Technician/Engineer  
*mmcassey@admiralcraft.com*

Kenny Printz - Sales Coordinator  
*kprintz@admiralcraft.com*

Jeff Taylor - Vice President of Sales  
*jtaylor@admiralcraft.com*

Kerri Frino - Vice President of Operations  
*kfrino@admiralcraft.com*

**Corporate Headquarters:**

55 Jericho Turnpike  
Suite 302A  
Jericho, NY  
Phone: 516-433-3535  
Toll Free: 800-223-7750  
Fax: 800-447-7751

**Main Distribution Center:**

6422 Harney Road  
Suite B  
Tampa, FL 33610