

Installation, Operation and Maintenance Manual

Please read and save these instructions. Read carefully before attempting to assemble, install, operate or maintain the product described. Protect yourself and others by observing all safety information. Failure to comply with instructions could result in personal injury and/or property damage! Retain instructions for future reference.

Model XGH20



General Safety Information

Only qualified personnel should install this unit. Personnel should have a clear understanding of these instructions and should be aware of general safety precautions. Improper installation can result in electric shock, possible injury due to coming in contact with moving parts, as well as other potential hazards. Other considerations may be required if seismic activity is present. If more information is needed, contact a licensed professional engineer before moving forward.

1. Follow all local electrical and safety codes, as well as the National Electrical Code (NEC), the National Fire Protection Agency (NFPA), where applicable. Follow the Canadian Electric Code (CEC) in Canada.

DANGER

Always disconnect power before working on or near a unit. Lock and tag the disconnect switch or breaker to prevent accidental power up.

CAUTION

When servicing the unit, motor may be hot enough to cause pain or injury. Allow motor to cool before servicing.

Receiving

Upon receiving the product check to make sure all items are accounted for by referencing the bill of lading to ensure all items were received. Inspect each crate for shipping damage before accepting delivery. Notify the carrier if any damage is noticed. The carrier will make notification on the delivery receipt acknowledging any damage to the product. All damage should be noted on all the copies of the bill of lading which is countersigned by the delivering carrier. A Carrier Inspection Report should be filled out by the carrier upon arrival and the Traffic Department. If damaged upon arrival, file claim with carrier. Any physical damage to the unit after acceptance is not the responsibility of the manufacturer.

Unpacking

Verify that all required parts and the correct quantity of each item have been received. If any items are missing, report shortages to your local representative to arrange for obtaining missing parts. Sometimes it is not possible that all items for the unit be shipped together due to availability of transportation and truck space. Confirmation of shipment(s) must be limited to only items on the bill of lading.

Handling

Units are to be rigged and moved by the lifting brackets provided or by the skid when a forklift is used. Location of brackets varies by model and size. Handle in such a manner as to keep from scratching or chipping the coating. Damaged finish may reduce ability of unit to resist corrosion.

Storage

Units are protected against damage during shipment. If the unit cannot be installed and operated immediately, precautions need to be taken to prevent deterioration of the unit during storage. The user assumes responsibility of the unit and accessories while in storage. The manufacturer will not be responsible for damage during storage. These suggestions are provided solely as a convenience to the user.

The ideal environment for the storage of units and accessories is indoors, above grade, in a low humidity atmosphere which is sealed to prevent the entry of blowing dust, rain, or snow. Temperatures should be evenly maintained between 30°F (-1°C) and 110°F (43°C) (wide temperature swings may cause condensation and “sweating” of metal parts). All accessories must be stored indoors in a clean, dry atmosphere.

Remove any accumulations of dirt, water, ice, or snow and wipe dry before moving to indoor storage. To avoid “sweating” of metal parts allow cold parts to reach room temperature. To dry parts and packages use a portable electric heater to get rid of any moisture build up. Leave coverings loose to permit air circulation and to allow for periodic inspection.

The unit should be stored at least 3½ in. (89 mm) off the floor on wooden blocks covered with moisture proof paper or polyethylene sheathing. Aisles between parts and along all walls should be provided to permit air circulation and space for inspection.

Inspection and Maintenance during Storage

While in storage, inspect once per month. Keep a record of inspection and maintenance performed.

If moisture or dirt accumulations are found on parts, the source should be located and eliminated.

REMOVING FROM STORAGE — As units are removed from storage to be installed in their final location, they should be protected and maintained in a similar fashion, until the equipment goes into operation.

Prior to installing the unit and system components, inspect the unit assembly to make sure it is in working order.



Table of Contents

Grease Grabber™ H ₂ O System Function.....	3
Cleaning Cycle	
Manual and Automatic Engagement.....	4
Fire Mode.....	4
System Components	
Hood	5
Grease Grabber H ₂ O Control Cabinet.....	5
Graphic Keypad	5
Unpacking.....	6
Hood Widths and Base Weights.....	6
Installation Overview	
Filler Panels	7
Back Supply Plenum.....	7
Hood Hanging Height.....	8
Double Island Style	8
Installing U-Channel Strip.....	8
Continuous Capture Plenum	8
Ductwork	9
External Supply Plenums.....	9-10
Supply Plenum Clip	9
Uni-Strut	10
Threaded Rod	10
Supply Duct Collar	10
UL Listed Fastener.....	11
Back Supply Plenum.....	11-12
Supply Duct Collar	11
Hanging the Back Supply Plenum	11-12
Hanging the Hood.....	12
Air Diffusers	12
Enclosure Panels.....	13
End Skirts	13
Backsplash Panels.....	14
Duct Collar.....	15
Plumbing	
Pump Installation	16
Connections	16
Detergent Tank	17
Electrical	
Wiring.....	17
Timer Programming – 24 Hour / 7 Day	
Programming / Operation	18
Initial System Start-Up	19
Sequence of Operation	20
Airflow Testing Procedure	21
Wiring Schematic	
Amerex®.....	22
Ansul®	23
Wiring Diagram.....	24
Maintenance	
Filters	25
Floats	25
Troubleshooting.....	26
Replacement Parts.....	26
Grease Grabber H ₂ O Start-Up Checklist.....	27
Maintenance Log.....	Backcover
Warranty.....	Backcover

Grease Grabber™ H₂O System Function

Accurex XGH₂O hoods are designed for three primary functions:

- Capture and contain the effluent produced by the cooking process.
- Remove grease and other contaminants from the airstream with two stages of mechanical filters (Primary Grease X-Tractor filters and secondary Grease Grabber filters).
- Wash the filters and other surfaces within the exhaust plenum to remove contaminants.

NOTE

The wash sequence of the hood is not designed for fire suppression and will not engage in the event of a fire.

NOTE

The functions listed above require the control center to be wired to the exhaust fan(s) and the hood plumbed.

NOTE

For a complete list of functions, please refer to the sequence of operations.

Normal Exhaust Operation and Contaminant Collection

The system's exhaust fan is manually controlled by a press-button switch (FAN ON/OFF) on the graphic keypad (included with hood). The exhaust system operates until the FAN ON/OFF button is pressed. The wash cycle can be manually engaged to run on a pre-programmed control sequence by pressing the CLEAN HOOD button or automatically engaged to run at the same time each day through a programmable timer.

Cleaning Cycle

Manual Engagement

The wash function is triggered by pressing the Clean Hood button after the exhaust fans are shut down at the end of each day's cooking operations (pressing the Fans On/Off button).

Hot water and detergent will fill the hood reservoir. The soapy water will then be cycled through the hood by the attached recirculation pump, cleaning both the filter banks and the exhaust plenum area on a timed cycle.

When the cleaning cycle is complete, the water is purged from the reservoir by the pump and the reservoir will again fill with clean hot water.

A rinse cycle will then run on a timed cycle and the water will again be purged by the pump.

When the cycle is complete, the controller runs the exhaust fans briefly to remove steam and excess moisture from the exhaust system.

Automatic Engagement

The hood is equipped with an automatic timer. The timer will automatically initiate the wash sequence at the programmed time each day. All other washing functionality will be the same as the manual engagement sequencing.

Fire Mode

In the event of a fire, the hood exhaust fan(s) will turn on at full power and the supply fan will turn off (default setting controlled by others) regardless of current fan operation. If the hood is in a wash cycle, the hood will drain and the fans will turn on.

NOTE

The wash sequence of the hood is not designed for fire suppression and will not engage in the event of a fire.



System Components

Hood

The hood is shipped from the factory pre-piped and ready to install. All wash components within the hood are complete and ready for connection to hot water, sanitary sewer drain and the electrical sources. Wiring from the control panel to the hood (for lights) is by manufacturer. All plumbing and wiring must conform to plumbing and electrical codes. Duct collars are factory mounted unless specified otherwise.

NOTE

Filters are shipped loose with the hood and installed in the field. See page 25 for installation details.

Grease Grabber H₂O Control Cabinet

The control cabinet contains all of the water and electrical components, and connections including the Programmable Logic Controller (PLC), that controls the wash sequencing and operations. The control cabinet also includes the detergent reservoir, detergent pump, recirculation pump, solenoid valves and other water piping.

NOTE

The recirculation pump is shipped loose with the hood. See pages 16 for installation details.

Graphic Keypad

The graphic keypad is the interface between the control functions of the XGH2O hood and the user. This keypad is typically mounted on the Grease Grabber H₂O control cabinet, but can also be shipped loose for remote mounting. The keypad consists of three main buttons: hood lights, fan on/off and clean hood. The keypad also has system fault and fill detergent indicator lights to alert of any fault in the system or when the detergent tank is low.

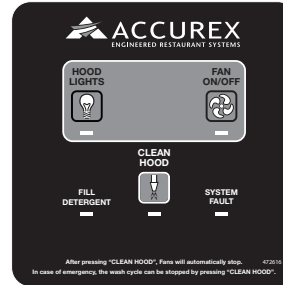

XGH2O Keypad



XGH2O and Vari-Flow Keypad

NOTE

If the XGH2O is being used with the Vari-Flow Air Management system, there will be an additional FAN 100% button for sending fan speeds to 100%. For detailed information on the Vari-Flow Air Management system, please refer to the Accurex website, www.accurex-systems.com

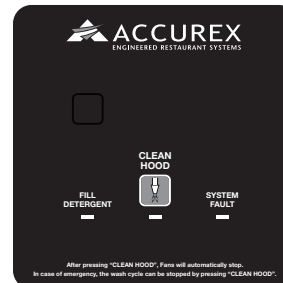

XGH2O and Melink® Intelli-Hood® Keypad

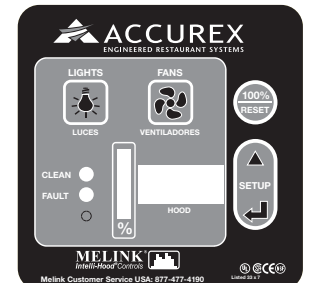

NOTE

If the XGH2O is being used with the Melink Intelli-Hood system, there will be two keypads. The Melink Keypad will control the fans and lights. The XGH2O Keypad will control the wash system.

NOTE

For information on PLC programming, please consult the factory.

Unpacking

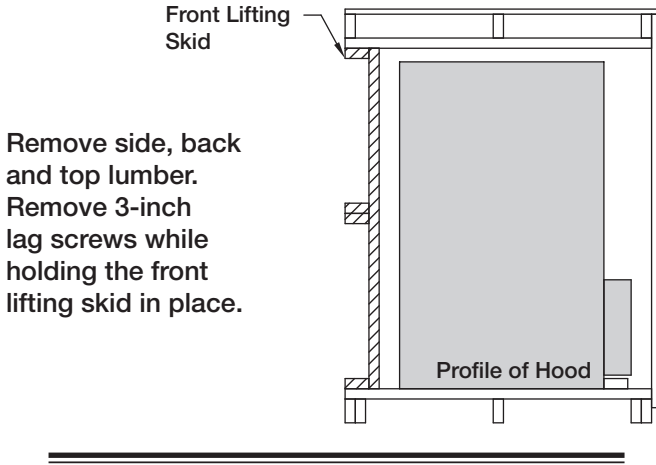

Remove side, back and top lumber. Remove 3-inch lag screws while holding the front lifting skid in place.

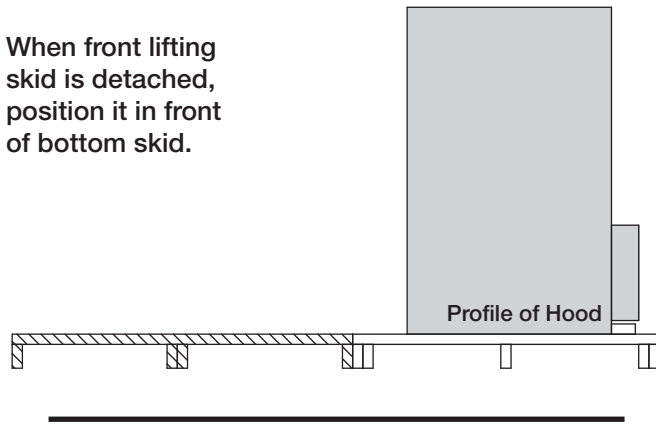

When front lifting skid is detached, position it in front of bottom skid.

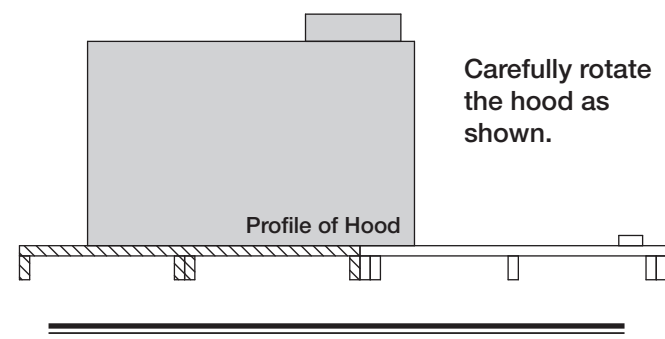

Carefully rotate the hood as shown.

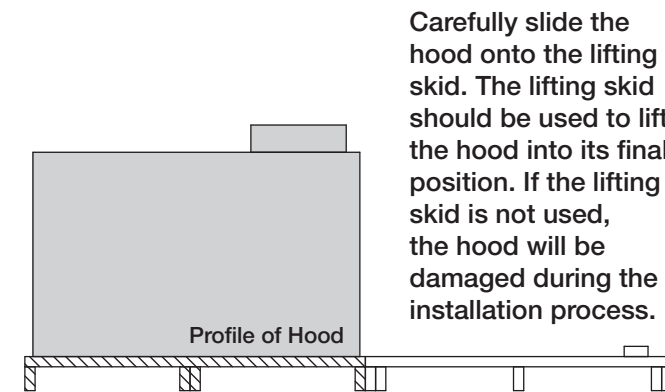

Carefully slide the hood onto the lifting skid. The lifting skid should be used to lift the hood into its final position. If the lifting skid is not used, the hood will be damaged during the installation process.

Hood Width and Base Weights		
Hood Width	Base Weight without Water	Base Weight with Water
inches (cm)	lbs. (kg)	lbs. (kg)
48 (121.92)	440 (199.58)	488 (221.35)
51 (129.54)	449 (203.66)	497 (225.44)
54 (137.16)	457 (207.29)	505 (229.06)
57 (144.78)	465 (210.92)	513 (232.69)
60 (152.40)	474 (215.00)	522 (236.78)
63 (160.02)	483 (219.09)	531 (240.86)
66 (167.64)	491 (222.71)	539 (244.49)
69 (175.26)	499 (226.34)	547 (248.12)
72 (182.88)	508 (230.43)	556 (252.20)

Base weight is based on 48 inches (121.92 cm) hood length. For each additional foot of hood in length, add 55 lb/ft (24.95 kg/m) in weight of hood and 67 lb/ft (30.39 kg/m) in weight of hood filled with water.

Example of a 10 foot hood:

Dry: 48 inch width x 120 inch length
 = 440 lbs. + (6 ft. x 55 lb/ft)
 = 440 lbs. + 330 lbs.
 = **770 lbs.**

With Water: 48 inch width x 120 inch length
 = 488 lbs. + (6 ft. x 67 lb/ft)
 = 488 lbs. + 402 lbs.
 = **890 lbs.**

DANGER

The maximum weight (weight with water) should be used for the maximum weight of the hood to ensure the ceiling structure can support the weight of the hood when filled with water.

CAUTION

To ensure proper structural support, all hanger brackets must be used for hanging the hood.



Installation Overview

Filler Panels

1. Unpack the hood and lay it on the lifting skid.
2. Bolt the filler panels together with 5/16 in. bolts provided in the hardware package.
3. Position the filler panels to the hood back, and tack-weld them into place.
4. To allow for ease of cleaning, caulk the external seams with NSF Approved silicone caulk (GE SCS1000, or its equivalent). The caulk is not provided.

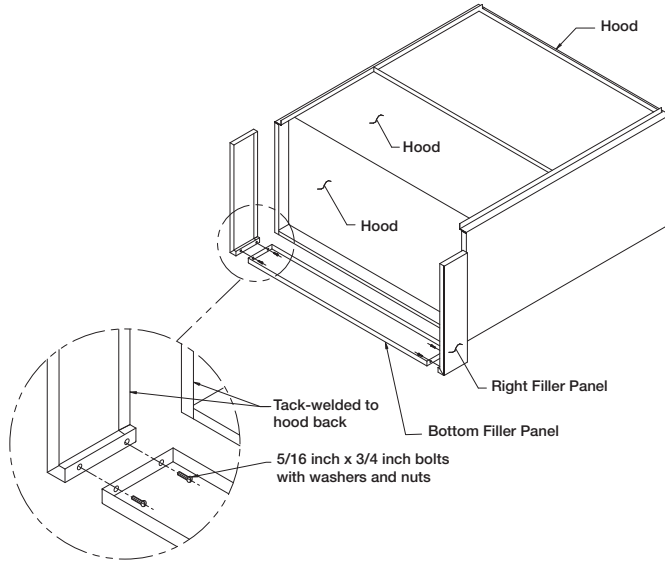

NOTE

If you have a Back Supply Plenum (BSP), this must be installed before the hood. Refer to page 11 for instructions on installing the BSP.

NOTE

All hanger brackets must be used and the hood must be properly supported while lifting to prevent damage or distortion to the hood. The hood must be hung level to operate properly.

After the hood is secured, make the exhaust duct connections. The fire system distributor must be contacted at this time. After the fire system has been installed, mount the enclosures, then the supply plenums. If an Horizontal Supply Plenum is provided, it should be installed before the enclosures. The hood and accessories are now installed.

Finally, make the electrical connections from the controls to the fans and complete the fire system circuits as required by the job specification (job specific wiring diagram located inside the cabinet cover).

Hood Hanging Height

The hood hanging height is critical. Hanging the hood at the incorrect height may significantly reduce the ability for the hood to function properly and may be in violation of codes. The hood hanging height (typically, 78 in. (198.12 cm) above the finished floor) is given on the UL label located on the inside of the hood on the end panel. The hood must be hung level to operate properly.

NOTE

Before hanging the hoods, please verify the hood marks to make sure the correct hood is hung on the correct side.

Double Island Style Hoods

A double island hood is created by installing two wall style hoods back to back. Use the installation procedure for single island hoods; install and level both hoods. After leveling, secure the hoods together by tack-welding and/or bolting the rear mounting brackets. Caulk this joint with NSF Approved silicone caulk (GE SCS1000 or its equivalent). The caulk is not provided.

Installing U-Channel Strip

1. After the hood is hung in position and leveled, apply caulk to the inside edge of the double island clip.
2. Position and install the clip by tapping into position along clip (friction fit).
3. Caulk edges to seal out grease and allow for ease of cleaning. Caulk with NSF Approved silicone caulk, GE SCS1000, or its equivalent. The caulk is not provided.

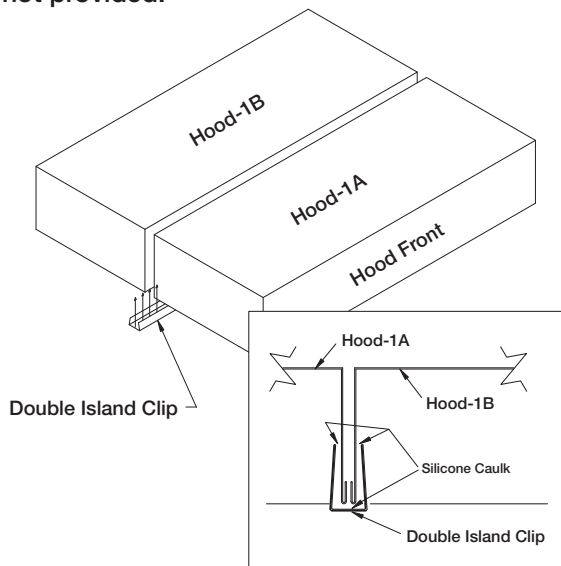

NOTE

The installation of the canopy hoods shall be in accordance with NFPA 96 (latest edition), Standard for Ventilation Control & Fire Protection of Commercial Cooking Operations.

NOTE

Accurex does not recommend walking or standing on the hood top as damage can result. If you must walk on the hood top, protect the hood with additional support or planks for flooring.

Continuous Capture Plenum Hoods

Remove the support angles on the open end panels. Use the installation procedure described for single island hoods; install and level both hoods. After leveling, secure the hoods together by tack-welding and/or bolting the top angles. Fasten the hoods together using u-clips and bolts. Caulk this joint with NSF Approved silicone caulk (GE SCS1000 or its equivalent). The caulk is not provided.

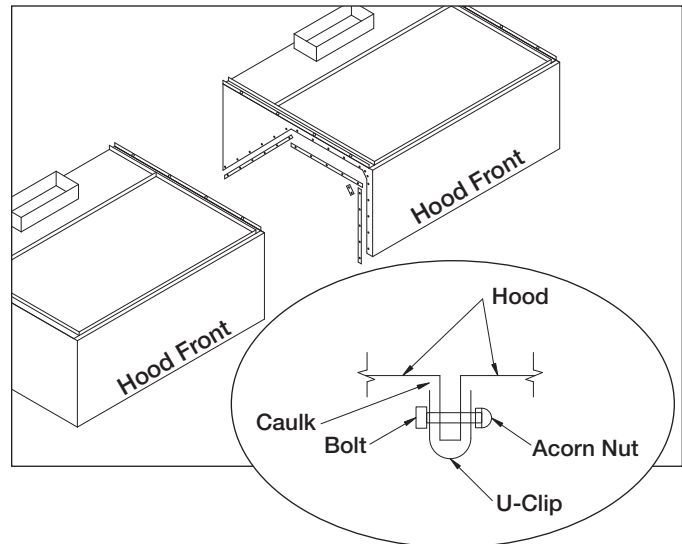

NOTE

- For multiple hood systems that have more than 14 lights total (incandescent or fluorescent), the hood lights must be wired to multiple circuits. Each circuit must have less than 14 lights total.
- Light bulbs are not provided. Standard light bulbs up to 100 watts may be used.

Ductwork

Exhaust

As specified in NFPA 96, Ch. 7.5 (latest edition), exhaust duct systems must be constructed in the following manner:

Materials: Ducts shall be constructed of and supported by carbon steel not less than 1.37 mm (0.054 in.) (No. 16 MSG) in thickness or stainless steel not less than 1.09 mm (0.043 in.) (No. 18 MSG) in thickness.

Installation: All seams, joints, penetrations, and duct to hood collar connections shall have a liquid-tight external weld. If you have an Automatic Fire Damper please refer to that manual for installation instructions now.

Supply

Supply ductwork (where applicable) should be connected to the hood in a manner approved by the local code authorities.

For proper installation of duct collars when they are shipped unattached see Installing Duct Collars on page 10.

NOTE

For hoods with fire dampers in the exhaust and supply duct collars, an access panel for cleaning and inspection shall be provided in the duct. This panel shall be as close to the hood as possible but should not exceed 18 in. (45.72 cm).

Installing External Supply Plenums

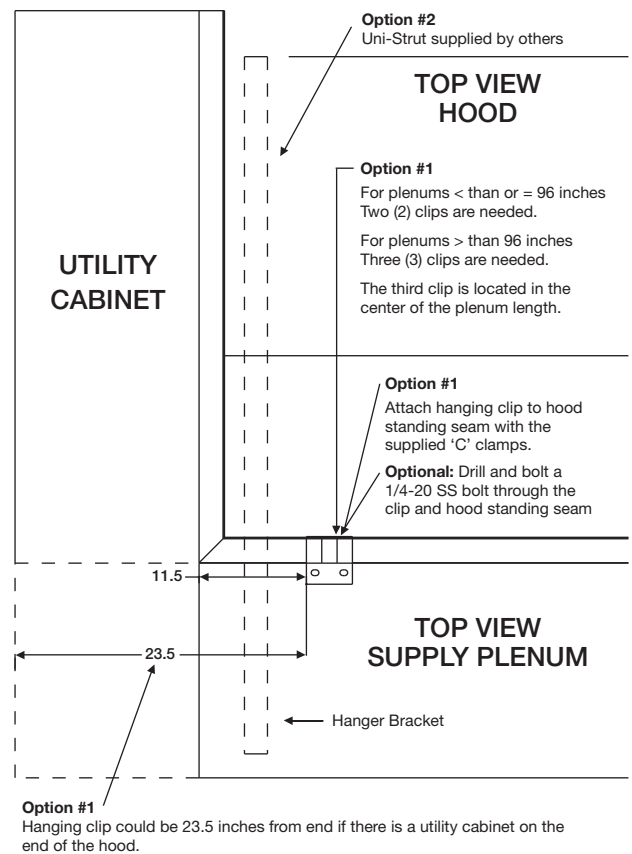

Using the Supply Plenum Clip - Option #1

1. Bolt the hanging clip to the supply plenum. Two clips are needed for plenums less than 96 in. (243.84 cm) long and three for plenums greater than 96 in. (243.84 cm). The third clip is located in the center of the plenum length. If there is a utility cabinet, the hanging clip should be 23.5 in. (59.69 cm) from the end to the hood.
2. Using the c-clamps provided, clamp the supply plenum hanging clip to the hood standing seam. Option: Drill and bolt a 1/4-20 SS bolt through the clip and hood standing seam.

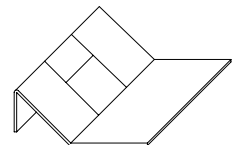

Supply Plenum Clip

Option #1 : Hanging Clip

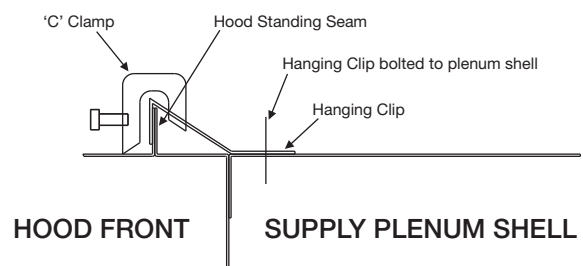

NOTE

The supply plenum is provided with plenum clips that assist in hanging the plenum. The plenum should not be hung only with the plenum clips; threaded rod or uni-strut must also be used.

Using the Uni-Strut - Option #2

1. The uni-strut (supplied by others) that holds the hood up, cantilevers over the end of the hood and is mounted to the supply plenum hanger brackets.

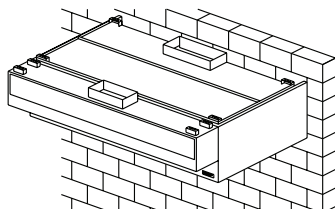
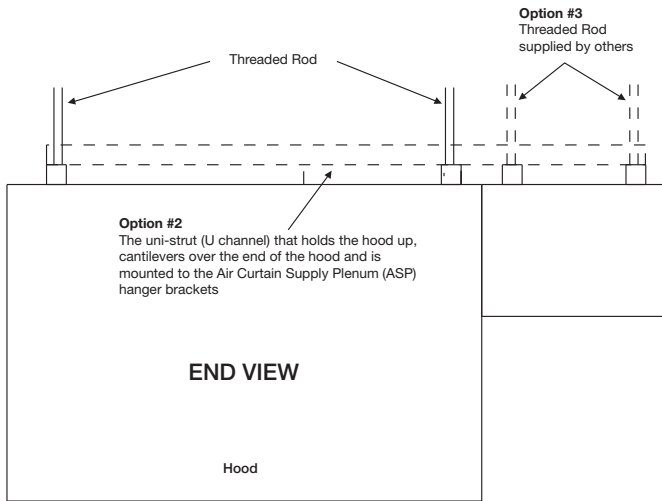

Variable Supply Plenum (HSP or VSP)

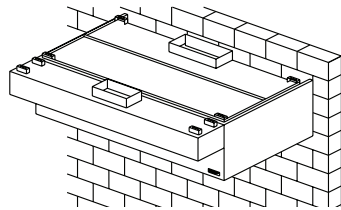

Air Curtain Supply Plenum (ASP)

Using the Threaded Rod - Option #3

1. Insert 1/2 in. (12.7 mm) diameter threaded rod (by others) into hanger brackets on the supply plenum top. Raise and hang the external supply plenum from adequate roof or ceiling supports.
2. The external supply plenum should be resting lightly against the hood. The hood is used to position the plenum only, it is not intended to support the plenum. All hanger brackets must be used and the plenum must be properly supported while lifting to prevent damage or distortion. The supply plenum must be hung level to operate properly.

(Optional fastening of supply plenum to hood. See directions).

3. It is recommended that caulk be applied at the mating seams and surfaces of the plenum, the hood, and the wall. If the supply plenum is next to a wall, you will also need to caulk around the surface next to the wall. Caulk the joints with NSF Approved silicone caulk (GE SCS1000, or its equivalent). The caulk is not provided.

Installing the Supply Duct Collar to the Plenum

1. Place the duct collar(s) over the opening, fastening with tack-welds at 1 to 2 in. (2.54 to 5.08 cm) intervals, or sheet metal screws at 3 to 6 in. (7.62 to 15.24 cm) intervals.

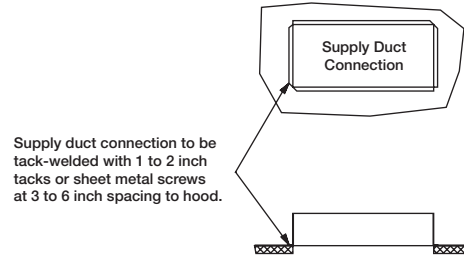

External Supply Plenum Weights, Dimensions and Supply Rates

External Supply Plenum Type	Weight		Width		Height		Length per section		Recommended Supply Rate	
	(lbs/ft)	(kg/ft)	(in)	(mm)	(in)	(mm)	(ft)	(m)		
Back Supply	35.0	15.878	6	152.4	Variable	Variable	3 to 16	.91 to 4.88	145 cfm/ft (246.36 m ³ /hr)	
Air Curtain Supply • 14 inch	9.5	4.31	14	355.6	10	254	3 to 16	.91 to 4.88	110 cfm/ft (186.89 m ³ /hr)	
Air Curtain Supply • 24 inch	12.5	5.67	24	609.6	10	254	3 to 16	.91 to 4.88	145 cfm/ft (246.36 m ³ /hr)	
Variable Supply	16.0	7.26	12	304.8	18	457.20	3 to 16	.91 to 4.88	curtain	0-80 cfm/ft (0-135.92 m ³ /hr)
									face	80-160 cfm/ft (135.92 -271.84 m ³ /hr)
Horizontal Supply	14.0	6.35	12	304.8	18	457.20	3 to 16	.91 to 4.88	150 cfm/ft (254.85 m ³ /hr)	

Using the UL Listed Fastener Provided

1. Drill a 9/32 in. hole for the 1/4 in. bolt from the inside of the supply plenum to inside the hood. Fasteners are to be located max. 6 in. (15.24 cm) from the end of the hood with max. spacing between bolts 36 in. (91.44 cm)

DO NOT INCLUDE UTILITY CABINETS OR FILLERS WHEN FIGURING BOLT PLACEMENT.

DO NOT BOLT THE SUPPLY PLENUM TO A FIRE/UTILITY CABINET.

2. Push bolt through hole, attach the washer and nut.
3. Hand tighten; then use a wrench until fully tightened. Caulk around bolts from inside of hood as necessary.

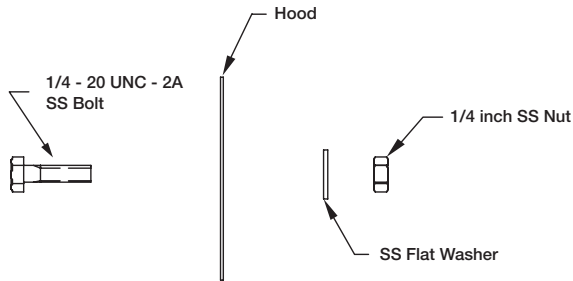

Installing the Back Supply Plenum

Installing the Supply Duct Collar

1. Find the center of the back supply plenum.
2. If the back supply plenum is less than 9 ft. 10 in. (299.72 cm) long, cut opening at the suggested location, centering the opening over the center of the back supply plenum.

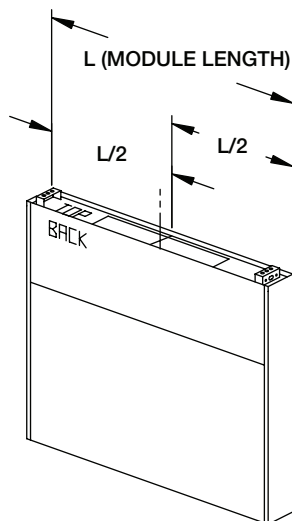

3. If the back supply plenum is greater than 9 ft. 10 in. (299.72 cm) long, divide the length of the back supply by four. This will give you the center of each half. Cut openings at the suggested location, centering the duct collar over the center measurement of each half.

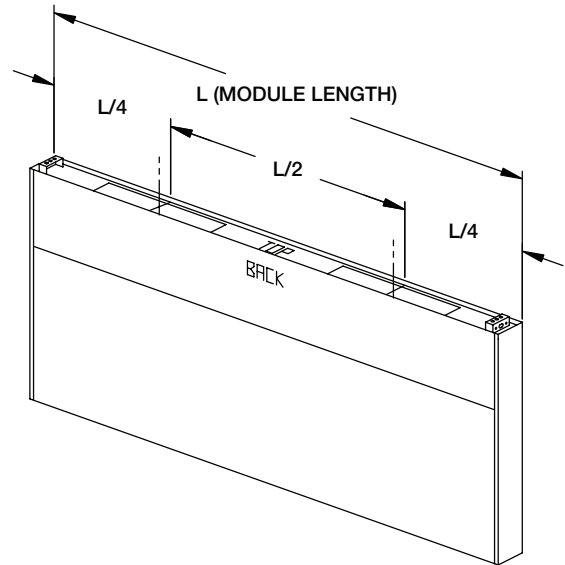

4. Place the duct collar(s) over the opening, fastening with screws or tack-welds every 4 to 6 in. (10.16 to 15.24 cm).

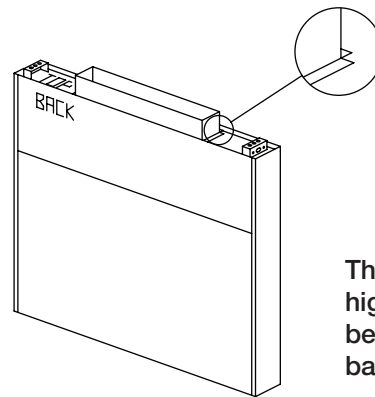

The 4 in. (10.16 cm) high duct collar is to be attached to the back supply.

Hanging the Back Supply Plenum

5. Hang the back supply plenum from the ceiling. The back supply plenum needs to be mounted 31.25 in. (79.375 cm) above the floor (based upon a canopy hood that will be hung at 78 in. (198.12 cm) above the finished floor. This is measured from the lowest rear edge of the back supply plenum to the finished floor. Leave 6 to 10 inches (15.24 to 25.4 cm) of space below the plenum for access to the air diffusers.

6. Fasten the back supply to the wall, going through the lower back supply wall.
 - These fasteners are to help maintain the location of the Back Supply, and are not intended to hold the weight of the back supply unit.
 - The fasteners should not interfere with the removable air diffusers.
 - The 31.25 in. (79.375 cm) height is based upon the canopy hood hanging height of 78 in. (198.12 cm)

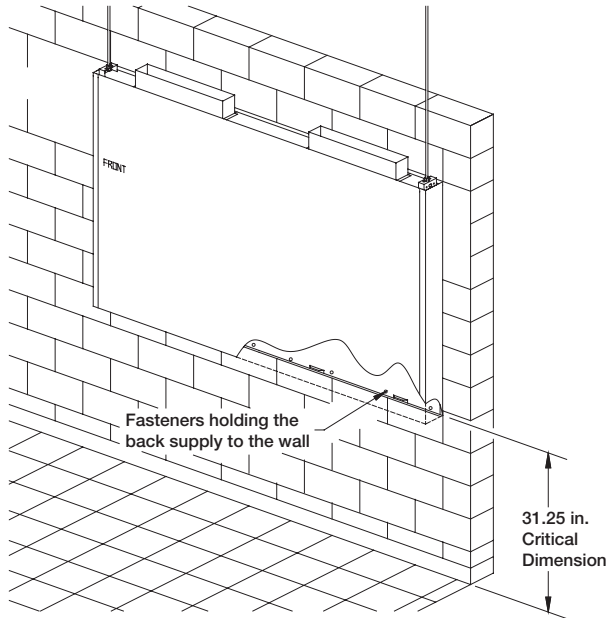

Hanging the Hood

Before hanging the hood according to the hood installation instructions, please check the following:

1. Make sure the back supply plenum is properly secured, as described in steps 5 and 6.
2. If the ductwork for the back supply plenum will not interfere with the hood installation, it should be connected now.
3. Any filler panels should be attached to the hood before the hood installation.
4. Lift the hood, and position it so the filler panels are resting lightly on the top outside edges of the back supply. The back supply is used to position the hood only. It is not intended to hold any hood weight.

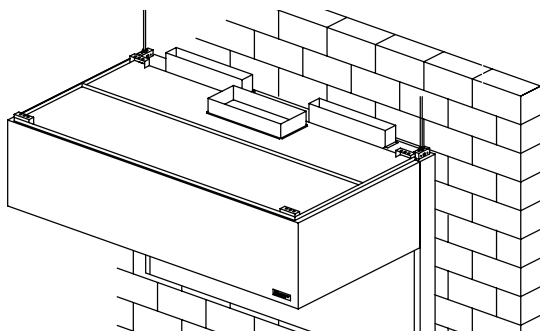

5. Connect the remaining ductwork for the back supply and the hood. It is recommended that caulk be applied at the mating seams and surfaces of the back supply, the hood, and the wall.

Air Diffusers

The air diffusers, located at the bottom of the back supply, will need to be cleaned as often as the application dictates. Inspect periodically to determine the cleaning schedule.

1. To clean the air diffusers, unfasten the screws. Remove the air diffusers from the back supply unit, and wash in the sink or dishwasher.
2. Insert the air diffusers at an angle from the bottom, and rotate so the forms are downward. Rest the diffuser on the internal angles.

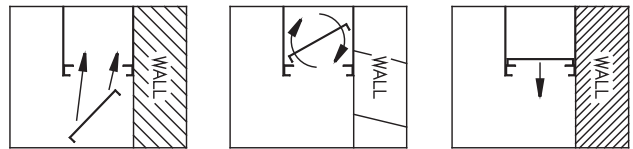

3. Refasten with the stainless steel screws.

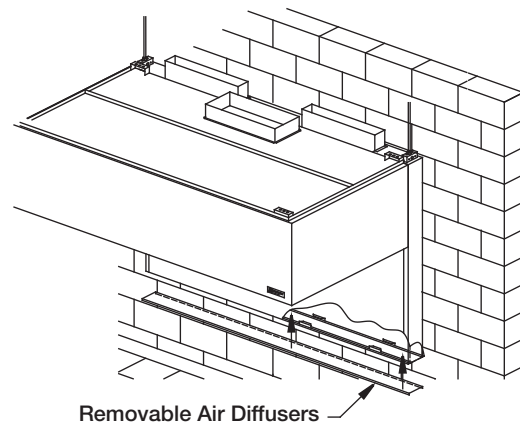

Installing Enclosure Panels

Before installing the enclosure panels, make sure the hood is hung in position with all the ductwork attached, electrical connections and fire system connections completed.

1. Position the end enclosure panels on the hood, and clamp into place with clamps provided or tack-weld the panels into place.
2. Fasten the end enclosure panels to the wall; method depends on wall construction. (Fasteners are not provided).

If the hood is a double island, bolt the end enclosure panels together. (Fasteners are not provided).

3. Position the front enclosure panel(s) on the hood, and bolt to the end enclosure panels with the 5/16 in. bolts provided in the hardware package.
4. Tack-weld or clamp the front enclosure panel(s) to the hood. If clamps are used, they must be positioned 4 in. (100 mm) from the ends, and in the center of the front enclosure panel.
5. To allow for ease of cleaning, caulk the external seams with NSF Approved silicone caulk (GE SCS1000, or its equivalent). The caulk is not provided.

Note: Installation instructions may not be applicable for concrete ceilings.

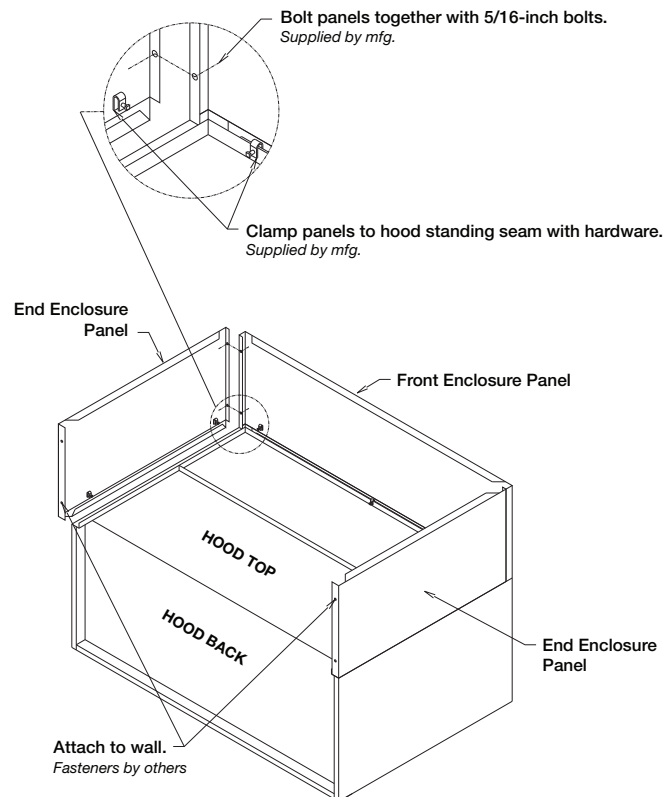

Installing End Skirts

1. After the hood is hung in position, slide the hemmed form on top of the end skirt onto the end panels of the hood.
2. Drill a hole in the hood end panel to line up with the hole in the end skirt. Attach the end skirt with a 1/4 in. bolt and cap nut to the inside of the hood, or tack-weld the end skirt to the hood.
3. Position the end skirt against the wall and attach. The method depends on the wall construction. (Fasteners for this are not provided).
4. Caulk the internal joint formed by the end skirt and the hood end panel with NSF Approved silicone caulk (GE SCS1000 or its equivalent). The caulk is not provided.
5. To allow for ease in cleaning, also caulk all the external seams.

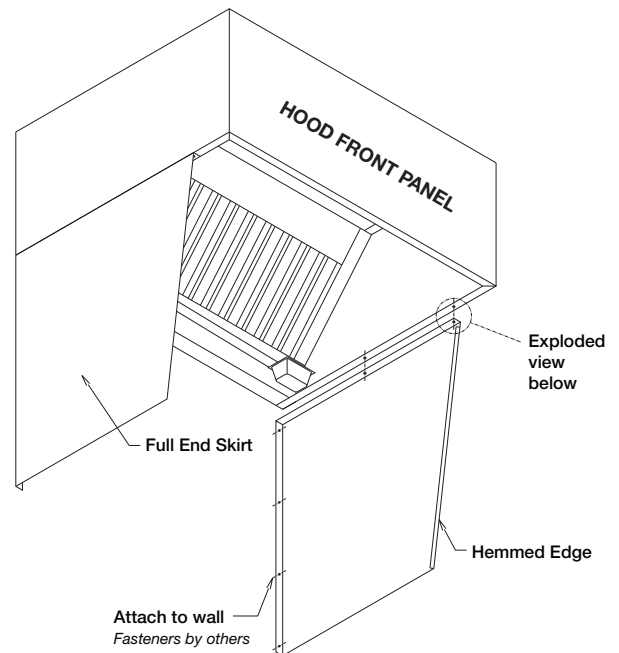

Exploded View

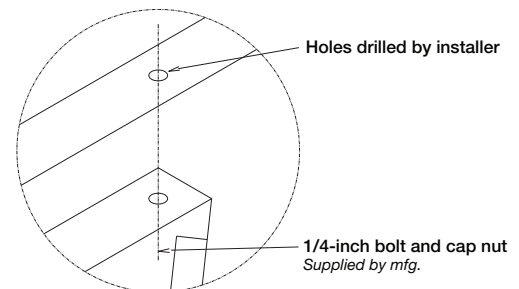

Installing Backsplash Panels

Flat backsplash panel
Material gauge – Stainless

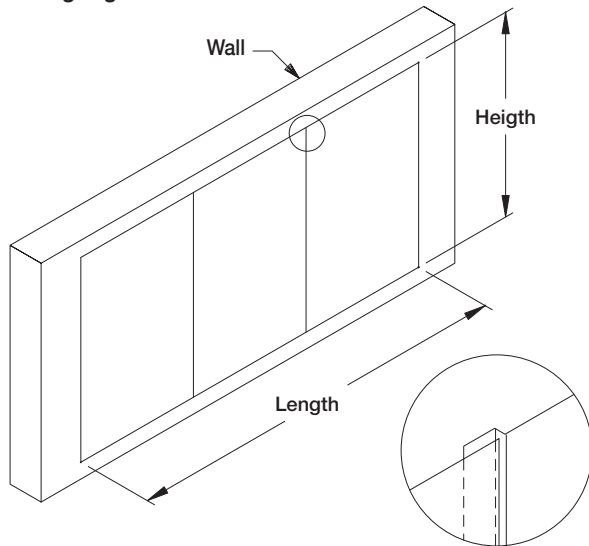

NOTE

Panels up to 47 inches (119.4 cm) wide ship in one piece. Over 47 inches (119.4 cm) in multiple pieces.

Insulated backsplash panel
Material gauge – Stainless
Insulation – 1 inch (25.4 mm)

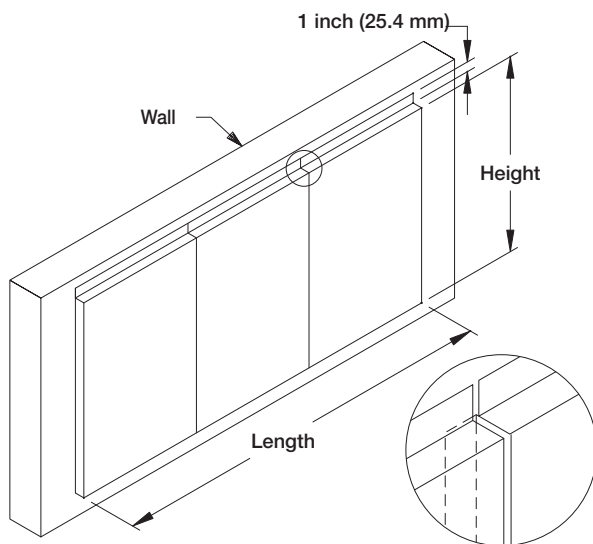

NOTE

Panels up to 45 inches (114.3 cm) wide ship in one piece. Over 45 inches (114.3 cm) in multiple pieces.

1. After the hood is hung in position, slide the flat flange of the backsplash panel behind the back of the hood.
Note: If the backsplash panel length is greater than 45 in. (114.3 cm), it will be shipped in multiple pieces.
2. After the backsplash panel has been positioned, drill holes in the panel and fasten to the wall. (Fasteners provided by others).
Note: The holes should be spaced to adequately secure the panel to the wall.
3. Caulk the joints between the hood and the backsplash panel with NSF Approved silicone caulk (GE SCS1000, or its equivalent). The caulk is not provided.
4. Caulk the joint between the backsplash panels when multiple panels are required, with NSF Approved silicone caulk (GE SCS1000, or its equivalent). The caulk is not provided.

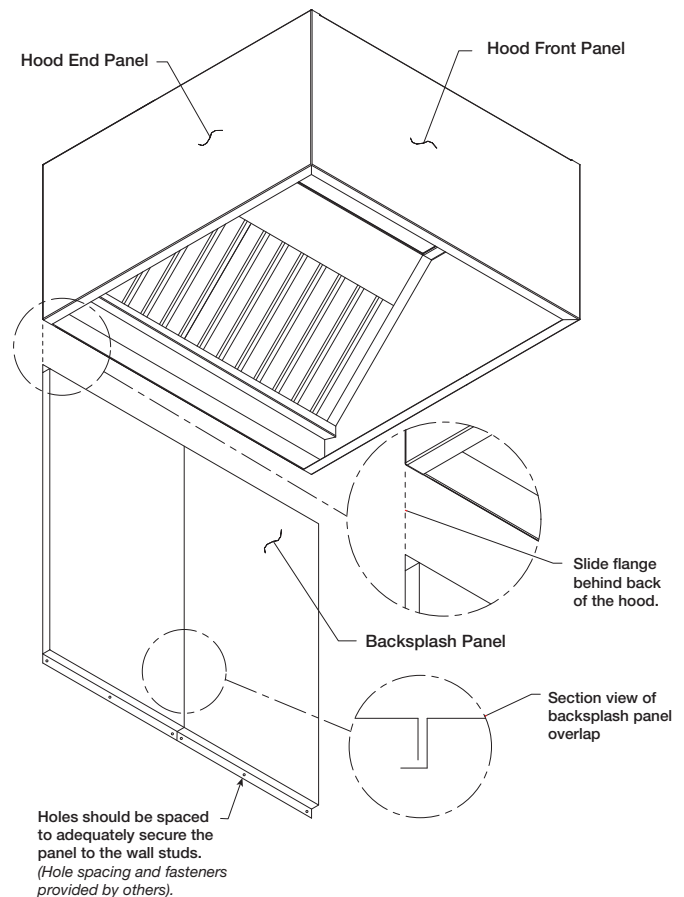

Installing Duct Collar

Overview of exhaust and supply plenum locations

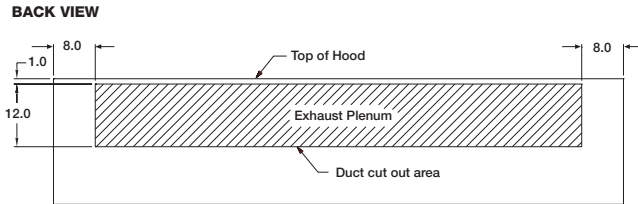
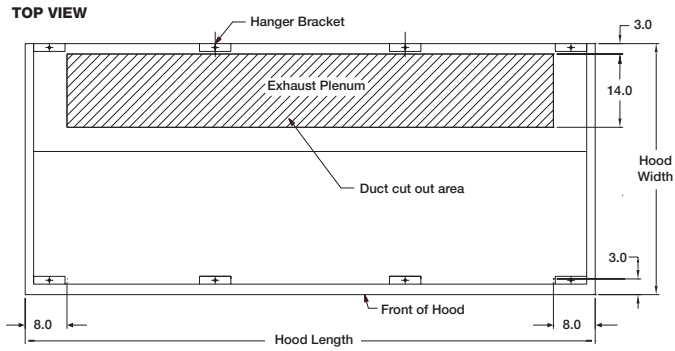

Dimensions are shown in inches.

1. The exhaust duct connection needs to be located within 48 in. (121.92 cm) from the center of the hood length to the center of the duct connection.
2. The exhaust duct connection is to be a continuous liquid-tight weld. Weld with a non-ferrous filler wire, such as silicon bronze or stainless steel filler wire. Protect all stainless steel areas from weld splatter.

Plumbing

Once the hood is hung, the recirculation pump and detergent tank (both shipped loose) must be installed in the controls cabinet.

Pump Installation

- Remove bolts from pump mounting plate in cabinet.
- Place the pump on the isolators located on the mounting plate with the bolts removed.
- Secure the pump to the mounting plate with the four previously removed bolts.
- Wire pump motor to the control cabinet per wiring diagram on the cabinet.
- The wires to power the motor are already connected to the pump motor. It only needs to be wired to the control cabinet.

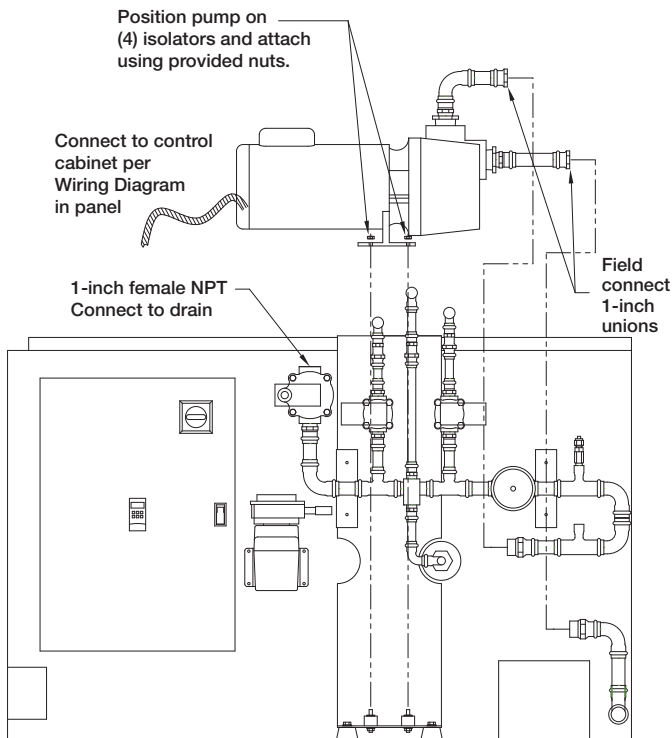

Plumbing Connections

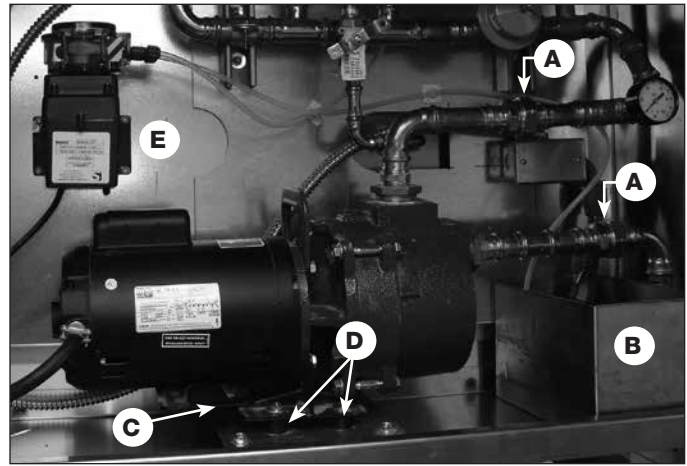

- A. One-inch unions
- B. Detergent tank
- C. Mounting plate
- D. Isolators (qty of four)
- E. Detergent pump

1. Connect the inlet and outlet piping on the recirculation pump to the respective piping in the cabinet via the threaded 1 in. unions.
2. Bring the inlet water piping to the connection located on the top of the hood and connect to the threaded connection on the 3/4 in. solenoid valve. A ball valve needs to be placed in the connection line before the 3/4 in. solenoid valve. Depending on water pressure, the inlet valve might need to be closed slightly to reduce water pressure. Water temperature should be 140°F.

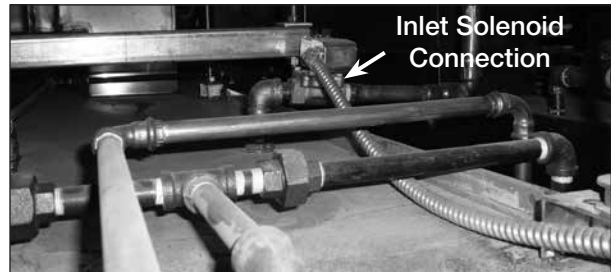

3. Bring the drain piping connection to the 1 in. solenoid valve in the control cabinet and connect to the threaded connection. This is a pressurized drain system and needs a properly sized drain to accommodate the pressurized drain water.

NOTE

As the suggested detergent is non-caustic and biodegradable, waste water from the hood can be drained in any typical grease trap.



Detergent Tank Installation

The detergent tank is located as shown in the photo. When installing the detergent tank, the low detergent indicator float and the detergent pump inlet tubing will need to be lifted. Once the tank is in position, the low detergent indicator float and detergent inlet tube must be lowered into place inside the tank.

- A. One-inch unions
- B. Detergent tank
- C. Mounting plate
- D. Isolators (qty of four)
- E. Detergent pump

Detergent Requirements

The detergent brand Formula G-510 (by 2010 Products, Inc.) is recommended by manufacturer for use in the wash system. Use Formula G-510 full strength. This product is biodegradable, non-caustic, and safe for kitchen staff to use. If G-510 detergent is not used, the cleanliness of the exhaust plenum and filters cannot be guaranteed.

Preventative Maintenance

The following practices will prolong the life of the detergent pump:

- Keep detergent tank filled.
- Avoid spilling detergent on the exterior of the pump.
- Clean the detergent tank at least every six months.
- Clean the detergent line strainer at least every six months.
- Check tightness of all fittings periodically.

The detergent pump motor has sealed bearings which do not require lubrication.

NOTE

G-510 is manufactured by 2010 Products, Inc., Food Service Division, Salem, Oregon 97303. For details and ordering information, call 800-286-2010.

Electrical

Electrical Wiring

All wiring must be done according to NEC (National Electrical Code NFPA #70) and local building codes. Two sources of power need to be brought into the electrical control cabinet. A 120 volt, 30 amp service with 12 gauge wire needs to be connected to terminals L1 on the disconnect switch and N. A 120 volt, 15 amp service with 14 gauge wire needs to be brought into the electrical cabinet and connected to terminal L2 on the disconnect switch and N1.

NOTE

The wash control station will provide a dry contact for a fan starter so the fans can be controlled by the PLC. The fan starter is not provided with the wash control station.

The main recirculating pump needs to be wired after it is installed in the hood. There are three 12 gauge wires in flexible conduit wired to the pump. Wiring to the pump is complete from the factory. The whip from the pump needs to be wired into the control cabinet.



Timer Programming – 24 Hour / 7 Day

Setting the Clock

1. Press and hold the CLOCK button.
2. Press and hold the DAY button until the display shows the current day.
3. Press the HOUR button until the display shows the current hour.
4. Press the MIN (minute) button until the display shows the current minute.

Setting the Programs

1. Press the PROG (program) button once. You will now set the time in which you want the wash to start. The number 1 in the lower left hand corner indicates that you are now programming Event 1.
2. Press the DAY button repeatedly until the display shows the day(s) when you want the timer to turn on. The options are:
 - **Days of the week**
MO, TU, WE, TH, FR, SA, SU
 - **Individual days of the week**
MO etc.
 - **Weekdays only**
MO, TU, WE, TH, FR
 - **Weekends only**
SA, SU
3. Press the HOUR and MIN (minute) buttons to set the time when you want the timer to turn on.
4. Press the PROG (program) button again.
5. Repeat steps 2-4 to set the OFF time for Event 1. This should be set one minute after the ON time.
6. When programming is complete, press the CLOCK button to display the current time.

Things you should know about programming events:

- You can repeat the ON and OFF programming procedures outlined above for up to seven (7) events as needed.

NOTE

While setting events, the timer may prematurely turn on the load, if you press the **MODE** button.

- Three kinds of settings can cause the timer to work in an unexpected way:
 - a. Set up events in progressive order of time, for example:
8:00 pm ON, 9:00 pm ON, 10:00 pm ON
Not 8:00 pm ON, 10:00 pm ON, 9:00 pm ON
 - b. Do not overlap event times, for example:
8:00 pm ON / 12:00 pm OFF and
9:00 pm ON / 11:00 pm OFF
 - c. Set the OFF time for one minute after the ON time.

Reviewing Events Programmed

In your current time display, press the PROG (program) button repeatedly to check your settings.

When finished, press the CLOCK button to return the display to the time of day.

Clearing (Deleting an Event)

1. Press the PROG (program) button as many times as necessary to locate the setting you want to clear.
2. Press and hold the MODE button.
3. Press the PROG button to clear the setting.
4. When finished, press the CLOCK button to return the display to the time of day.

Operating the Time Switch

Press the MODE button repeatedly to set the timer to Automatic, Random or Manual mode.

NOTE

For the time switch to run programmed events, it must be set to AUTO mode.

- **AUTO** runs all events automatically according to the schedule you have set. The word AUTO appears in the display.
- **RND** (random) runs all events in a RANDOM mode. This is a security feature in which ON and OFF times randomly differ +/- 15 minutes from the programmed times, creating a more “lived-in” look. The word RND appears on the display.

NOTE

Do NOT set this timer to RND mode. It will not wash at the exact time you programmed.

- **MANUAL** turns ON and OFF only when the user presses the ON or OFF button. The display is blank, showing neither RND or AUTO.

Overriding Timer Settings

The ON or OFF buttons override the current programmed events. To override the current program (either ON or OFF), press the ON or OFF button.



Initial System Start-Up

1. Check electrical power (see wiring diagram)
 - Correct supply voltage
 - Proper connections to fire suppression system
2. Check to make sure the disconnect switch on the electrical control cabinet is switched to the "ON" position.
3. Prime the recirculation pump. Remove the plug on top of pump and use a funnel to add water to the pump. This only needs to be done one time prior to initial start-up.
4. Add detergent to the detergent tank in the cabinet.
5. Clean the control cabinet of any debris that may have entered the cabinet during installation.
6. Close the cabinet doors and press the Fan On/Off button.
7. Check the exhaust and supply air volumes.
8. Press the Fan On/Off button to turn the fans off.
9. Press the Clean Hood button.



When the hood is filling, check to ensure water is not leaking through the edges of the access doors. If so, the inlet water pressure is too high. Slowly close ball valve located before the inlet solenoid on the hood top until no water leaks past the access doors.

After the hood fills with water and starts washing the primary filters, open water valve slowly until water mist is felt above equipment. Then slowly close valve until water mist is no longer felt above equipment. Once the valve is set it will not need to be moved again.

Verify the Grease Grabber H₂O sequence of operation (see the diagram of wash sequence on page 20) during the detergent pump cycle.

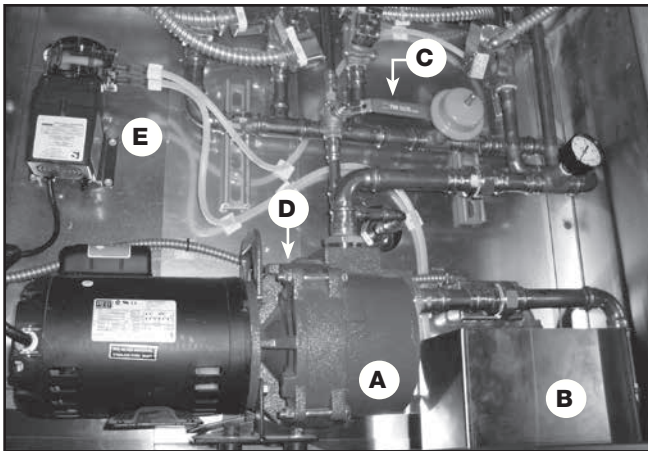

Interior of Cabinet

- A. Recirculating pump
- B. Detergent tank
- C. Water valve to adjust front primary filter nozzles
- D. Pump plug for priming
- E. Detergent pump

Daily Operation of the XGH2O Hood

Pressing the **FAN ON/OFF** button will start/stop the exhaust and supply fans if interlocked.

Pressing the **HOOD LIGHTS** button will turn on/off the hood lights.

Initiating the wash cycle:

The Grease Grabber H₂O has an automatic timer that can be set to control the wash schedule and automatically start the cycle. See **Timer Programming** on page 18.

To initiate the wash cycle manually, press the **CLEAN HOOD** button on the keypad. If you press this button while the fans are running, the system will stop the fans and then start the wash cycle. When the wash is completed, the system will automatically reset itself.

If the fans are controlled by a building management system (BMS), the steps above still apply unless a special program is requested to bypass having to initiate the wash cycle by pushing the **FAN ON/OFF** and **CLEAN HOOD** buttons.

Refer to the Grease Grabber™ H₂O Hood checklist on page 27 for detailed instructions on start-up operations.

Sequence of Operation - Grease Grabber™ H₂O

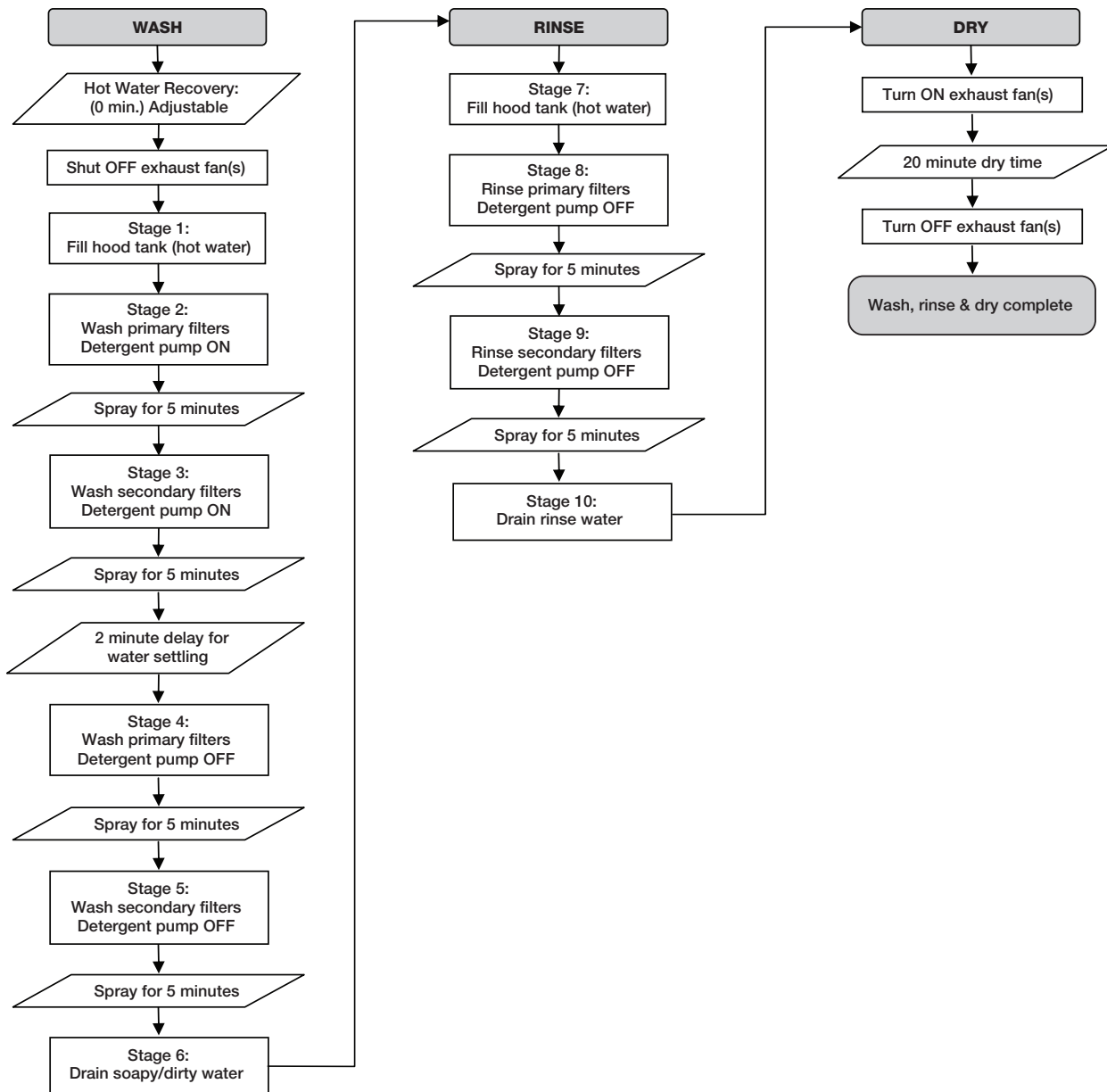

Normal Fan Operation

Exhaust Mode in Fire -- RUN

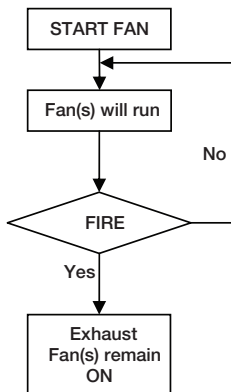

Exhaust Mode in Fire -- STOP

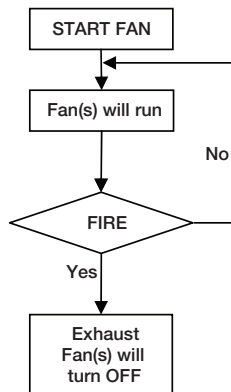

Temperature Interlock

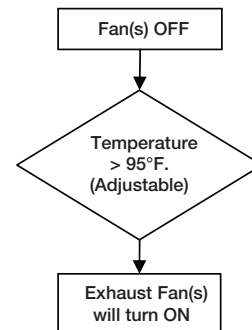

Airflow Testing Procedure

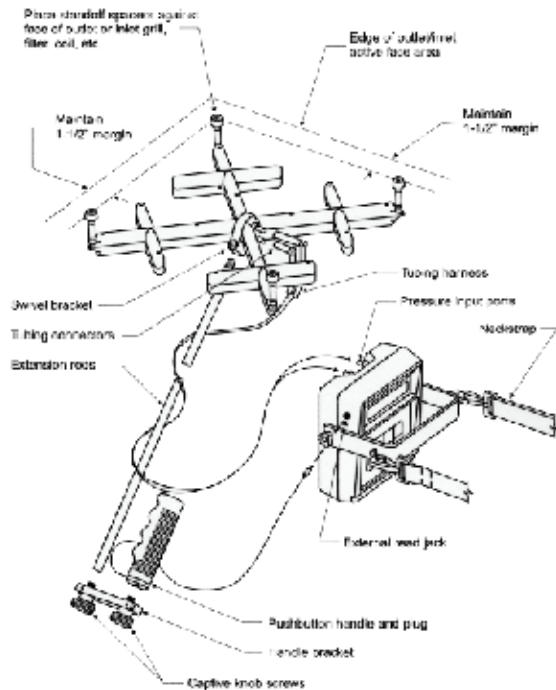

Short Ridge Meter Components

For measuring exhaust airflow rates (cubic feet per minute = CFM), use a short ridge meter to measure velocities along the inlet slot of the hood. To ensure accurate data, all appliances should be on. Multiple locations need to be tested as outlined below to ensure an accurate reading.

Hood Length	48 to 72 inches	72 to 120 inches	120 to 192 inches
Minimum Number of Test Locations	3	5	7

To take velocity readings along the length of the hood, the edge of the short ridge meter must start/stop six (6) inches from the end of the hood. Vertical placement of the short ridge meter along the inlet is shown.

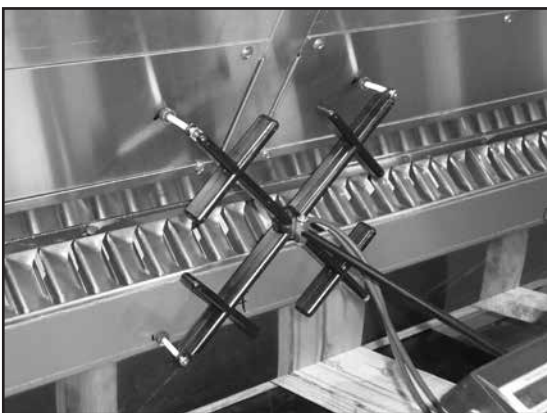

After the appropriate number of readings have been taken from the inlet slot of the hood, an average reading can be calculated by summing the velocity readings and dividing the total value by the number of readings taken.

$$\text{Average Velocity} = \frac{\text{Sum of Velocity Readings}}{\text{Number of Readings}}$$

Next calculate the total hood airflow volume (CFM) by using the following equation:

$$\text{Hood CFM} = [(\text{Length of Hood in inches} \times 4.846) \times (\text{Average inlet slot velocity} \times 2.47)] \div 144$$

NOTE

The constants 4.846 and 2.47 are factory derived for use with the Grease Grabber™ H₂O.

Calculation Example:

Five (5) inlet slot velocity readings (minimum)

Hood Length	96 inches				
Test Location (off left; in inches)	6	27	48	69	90
Velocity Reading (fpm)	175	210	250	190	160

$$\text{Average Velocity (FPM)} = (175 + 210 + 250 + 190 + 160) \div 5 = 197 \text{ FPM}$$

$$\text{Hood Exhaust Rate (CFM)} = [(96 \times 4.846) \times (197 \times 2.47)] \div 144 = 1572 \text{ CFM}$$

Amerex® Wiring Plan View

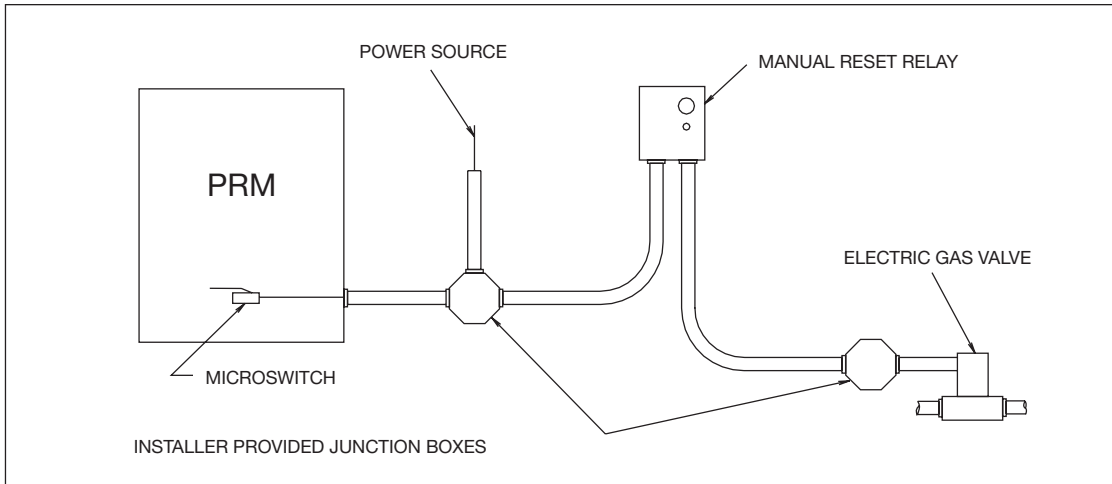

BASIC WIRING DIAGRAM

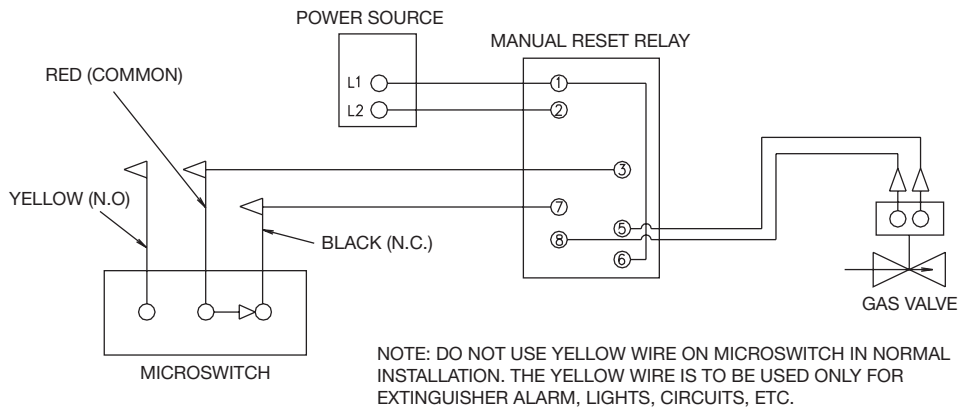

BASIC WIRING DIAGRAM

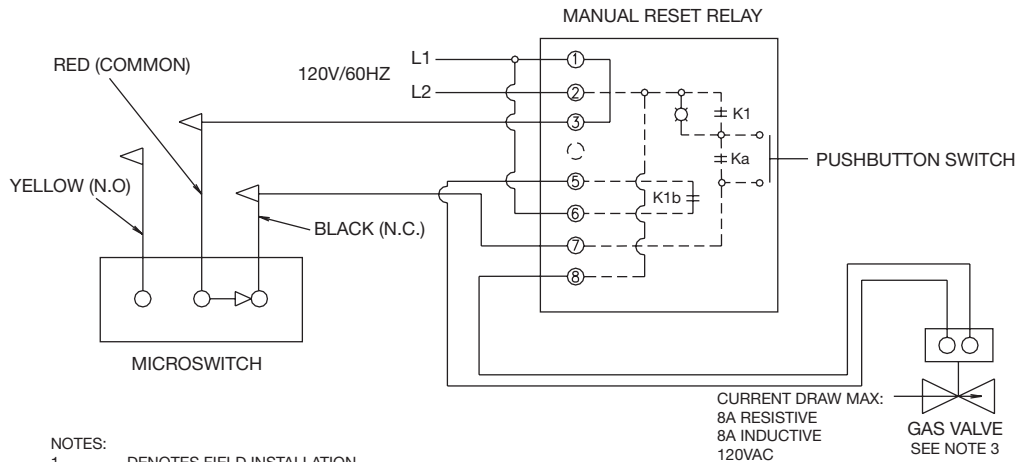

NOTES:

1. ---- DENOTES FIELD INSTALLATION
2. - - - - DENOTES FACTORY INSTALLATION
3. GAS VALVE: UL LISTED ELECTRICALLY-OPERATED SAFETY VALVE FOR NATURAL OR LP GAS AS NEEDED OF APPROPRIATE PRESSURE AND TEMPERATURE RATING, 110V/60HZ OR AMEREX GAS VALVES, PN 12870, 12871, 12872, 12873, 12874, 12875 and 12876.
4. K1a and K1b ARE N.O. WHEN K1 IS DE-ENERGIZED.

Ansul® Wiring Plan View

ANSUL SNAP-ACTION SWITCH
(SWITCH CONTACTS SHOWN WITH ANSUL
AUTOMAN IN THE COCKED POSITION)

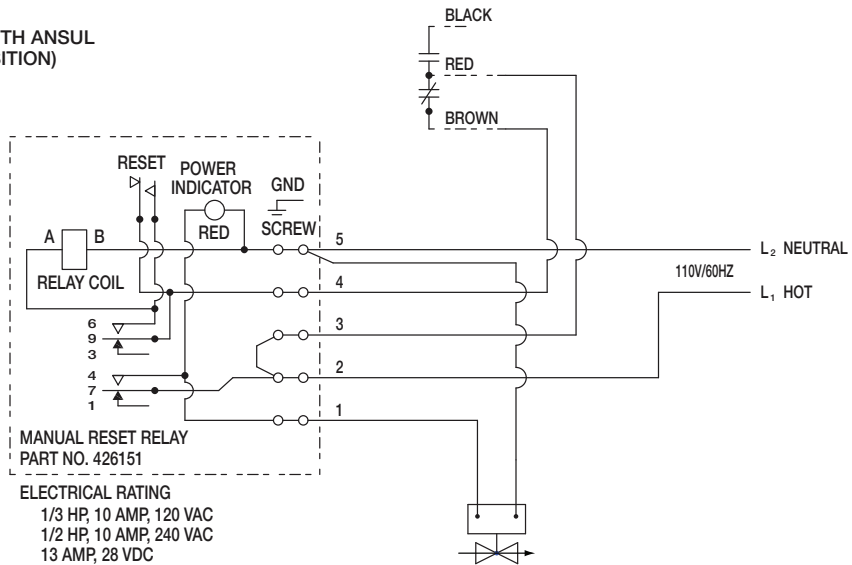

NOTE:

1. ——— DENOTES FIELD INSTALLATION
2. - - - - - DENOTES FACTORY INSTALLATION
3. GAS VALVES: "UL LISTED ELECTRICALLY-OPERATED SAFETY VALVE FOR NATURAL, OR LP GAS AS NEEDED OF APPROPRIATE PRESSURE AND TEMPERATURE RATING, 110V/60HZ OR ANSUL GAS VALVES, PART NUMBERS 13707, 13708, 13709, 13710. AND 17643.
4. DO NOT USE BLACK WIRE ON SNAP-ACTION SWITCH IN NORMAL INSTALLATION. (USED ONLY FOR EXTRANEIOUS ALARM, LIGHT CIRCUITS, ETC.)

ANSUL SNAP-ACTION SWITCH
(SWITCH CONTACTS SHOWN WITH ANSUL
AUTOMAN IN THE COCKED POSITION)

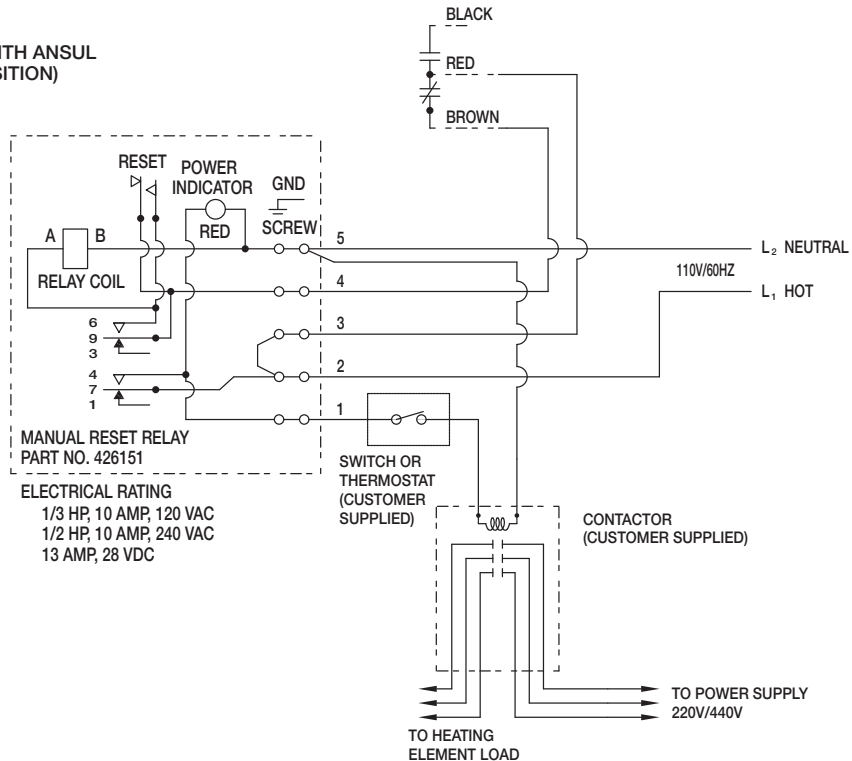

NOTE:

1. ——— DENOTES FIELD INSTALLATION
2. - - - - - DENOTES FACTORY INSTALLATION
3. GAS VALVES: "UL LISTED ELECTRICALLY-OPERATED SAFETY VALVE FOR NATURAL, OR LP GAS AS NEEDED OF APPROPRIATE PRESSURE AND TEMPERATURE RATING, 110V/60HZ OR ANSUL GAS VALVES, PART NUMBERS 13707, 13708, 13709, 13710. AND 17643.
4. DO NOT USE BLACK WIRE ON SNAP-ACTION SWITCH IN NORMAL INSTALLATION. (USED ONLY FOR EXTRANEIOUS ALARM, LIGHT CIRCUITS, ETC.)

Wiring Diagram

Wiring diagram is located on the inside cover of the control cabinet located on the end of the hood.

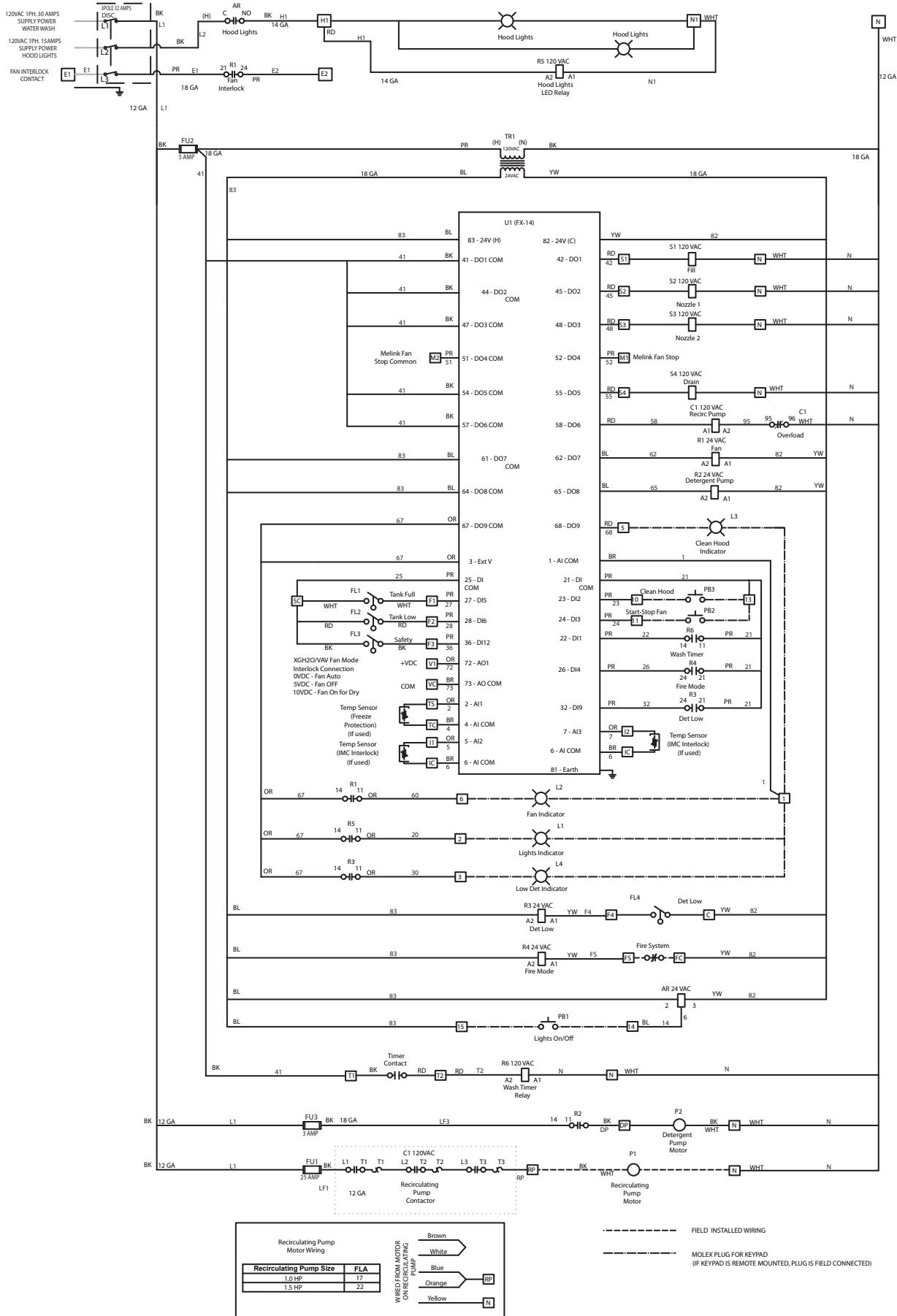

Maintenance

Capture Tank

The interior surfaces of the hood capture tank should be wiped down weekly.

Filters

The Grease Grabber filters (bead filters) require visually inspection (not removed from hood) two weeks after start-up, then once a month thereafter to make certain the filters are positioned correctly in the plenum. Positioned correctly means there are no gaps between the filters.

To inspect the bead filters, remove the fasteners holding the access doors; each door has five (5) fasteners. Remove every other door to inspect the filters.

After inspecting the filters, put the access doors back on and put the fasteners back in. Be careful not to over-tighten or cross thread the fasteners when putting them back in.

The Grease Grabber filters (bead filters) need to be removed from the hood once every three months to visually inspect and ensure the filters are structurally sound.

Remove all the doors and remove the filters for inspection. Depending on the equipment under the hood, it will probably be easier to remove the filters from the right side of each hood. Slide the other filters down to the end access door for removal.

After inspecting the filters, place them back in the hood. Be careful to install the filters with the handles up and make sure not to hit the fire detection line when removing or installing the filters. Ensure no gaps are between filters after installation.

If any filter appears damaged, consult factory for replacement.



Floats

The floats need to be inspected two weeks after start-up and then once a month thereafter.

The float can be inspected by first turning the **disconnect switch** on the control cabinet to the 'OFF' position. Then remove the large access panel door. Once the access panel is removed, you will have access to the floats.

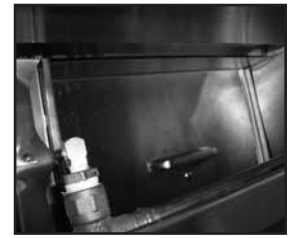

Access Panel Door



Float Installed

Slide each float (Low Float, High Float and Safety Float) up the stem to its stop with your finger and let go. If float slides freely down the stem with minimal resistance, the float is operating as it should. Put the access panel back on and turn the disconnect switch to the 'ON' position.

If the float does not slide freely down the stem, the stem and floats are dirty and need to be wiped off with a clean cloth. Cleaning the stem involves removing all the clips (stops). Slide floats up and down on the shaft as required to access and clean the entire length of the shaft. Return floats to their location and reinstall stops.

Make sure all float stops are securely located in their grooves and floats are located in their designated spots.

If for some reason the floats get taken off the stem, the stamped circle on the top side of the float needs to face up.

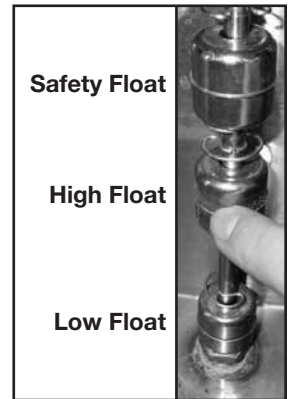

NOTE

Be careful when handling the **float stops**. These are small clips and can easily be dropped. If you loose one of these clips, consult factory for a replacement.

Troubleshooting

Hood is not cleaning

If the hood does not seem to be adequately cleaned, look for the following:

Detergent tank — is it empty or filled with wrong detergent?

Detergent pump — is the detergent pump running? Is there power to the pump? Is the detergent level low? If the hood plenum area is not sufficiently cleaning, consult factory for information on increasing duration of wash cycle and detergent pump.

Nozzles — are any of them clogged? If so, they can be removed and cleared using a small wire.

Water temperature — is it at least 140°F.

Hardness of water — test water for hardness level. It is recommended that soft water be used.

Hood not draining properly — plugged drain.

Ensure all floats have stamped circles facing up.

Water leaks — water leaking through the access panels when filling. Ensure access panels are securely in place. If leak persists, partially close inlet water ball valve (by others) upstream of fill solenoid to reduce water pressure.

Condensation in the hood — large amounts of condensation while hood is washing. Hood should be washed after the hood and equipment is warm, **not hot**. The warm equipment helps reduce the condensation that forms in the hood.

Approved wash detergent

Formula G-510 from 2010 Products, Inc.

Phone: 800-286-2010

(Not provided by manufacturer).

Replacement Parts

When ordering parts, please be prepared to provide us with your cabinet and hood system model number, and serial number from labels on the hood and cabinet. See the chart below to identify the replacement parts needed.

	Accurex Part Number	Grainger® Part Number
Wash Nozzles		
Above GG Filters	472806	
Below GG Filters	472795	
Before First Stage Filters	472805	
Repair Kits		
Solenoid Model 1A579		K-1180
Solenoid Model 1A578		K-1172



Grease Grabber™ H₂O Start-Up Checklist

Check boxes when item has been verified and gone over with customer.

Hook-Up

Electrical Connected

- 120V/1 30A to terminals L1 and N for wash controls
- 120V/1 15A to terminals L2 and N1 for hood lights
- Fans to terminals E1 and E2 (dry contact)
If using variable volume controls, Melink will also require connection to terminals M1 and M2, Vari-Flow will only require connection to terminals V1 and VC.
- Fire system microswitch to terminals FS and FC.
- Recirculating pump wired to cabinet terminals RP and N.
- If keypad is shipped loose, connection completed between keypad and cabinet with supplied cable. If additional cable is required, consult factory for ordering.

Plumbing Connected

- Two 1-inch unions to recirculating pump connected.
- Hot water supply line, 3/4-inch connection.
- Pressurized drain connection, 1-inch connection.
- Hot water supply ball valve open. Located up stream of the inlet water solenoid valve.

Detergent

- Suction tubing and strainer to bottom of detergent tank.
- Low detergent sensor in bottom of detergent tank.
- Detergent tank filled with proper detergent.

Timer, 24 hours / 7 day

- Programmed - see instructions on page 18.

Start-Up

Cooking Mode

- See sequence of operations on page 20.
- Hood lights on. Activate “Hood Lights” push button.
- Hood light LED indicator should be lit.
- Fans on. Hold “Fan On/Off” push button for one-half second.
- Fan LED indicator should be lit.
- Appliances on (gas and/or electric).

Stop Mode

- See sequence of operations on page 20.
- Fans off. Hold “Fan On/Off” push button for one-half second.
- LED indicator turns off.

Wash Mode

- See sequence of operations on page 20.
- If using 24 hour / 7 day timer, wash cycle will start at scheduled time after “Fan On/Off” push button has been pressed. (Refer to page 18 for details on programming 24 hour / 7 day timer). If 24 hour / 7 day timer is not being used, press “Clean Hood” push button after pressing “Fan On/Off” push button.
- Clean hood LED indicator should be lit.
_____ Record water pressure
(Should be between 30-50 psi)
_____ Record water temperature
(Should be between 140-160°F.)

Stop Mode

- At end of wash cycle, system returns to Fan On for 20 minutes dry cycle.
- System resets to stop mode.
- Hood lights off. Deactivate “Hood Lights” push button.
- All lights on face of keypad(s) should be off.

Fire Mode

- Trip fire system microswitch or remove wire from terminal FS or FC. (Water will not spray in fire mode, fans will run. If wash cycle is running during fire system trip, hood will drain and fan(s) will run).
- System fault LED indicator should be on.
- Fan LED indicator should be lit.

Low Detergent Mode

- Fill detergent tank with appropriate detergent.
- Low detergent LED indicator should go off.

Miscellaneous

Hood Access

- Panels should fit tightly to prevent water spraying out.
- When front nozzles are washing, adjust ball valve in cabinet to reduce water pressure and minimize overspray.

Cleaning

- Is the hood cleaning properly?
- If not, refer to troubleshooting guide on page 26.

Maintenance Log

Date _____ Time _____ AM/PM

Notes: _____

Date _____ Time _____ AM/PM

Notes: _____

Date _____ Time _____ AM/PM

Notes: _____

Date _____ Time _____ AM/PM

Notes: _____

Date _____ Time _____ AM/PM

Notes: _____

Date _____ Time _____ AM/PM

Notes: _____

Date _____ Time _____ AM/PM

Notes: _____

Date _____ Time _____ AM/PM

Notes: _____

Warranty

Accurex warrants this equipment to be free from defects in material and workmanship for a period of one year from the shipment date. Any units or parts which prove defective during the warranty period will be replaced at our option when returned to our factory, transportation prepaid. Motors are warranted by the motor manufacturer for a period of one year. Should motors furnished by Accurex prove defective during this period, they should be returned to the nearest authorized motor service station. Accurex will not be responsible for any removal or installation costs.

As a result of our commitment to continuous improvement, Accurex reserves the right to change specifications without notice.

AMCA Publication 410-96, Safety Practices for Users and Installers of Industrial and Commercial Fans, provides additional safety information. This publication can be obtained from AMCA International, Inc. at: www.amca.org.



Phone: (800) 333-1400 • Fax: (715) 241-6171 • Website: www.accurex-systems.com